

PRO-FORM[®]
CROSS WALK[™]  **PLUS**
DUAL MOTION CROSS TRAINER EXPANDED RUNNING SURFACE

SEARS[®]

Model No. 831.297350

Serial No. _____

The serial number can be found in the location shown below. Write the serial number in the space above.

Serial Number Decal

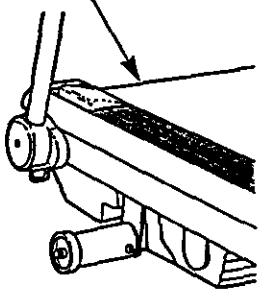

▲ CAUTION!:

Read all safety precautions and instructions in this manual before using this equipment. Keep this manual in a safe place for future reference.

OWNER'S MANUAL

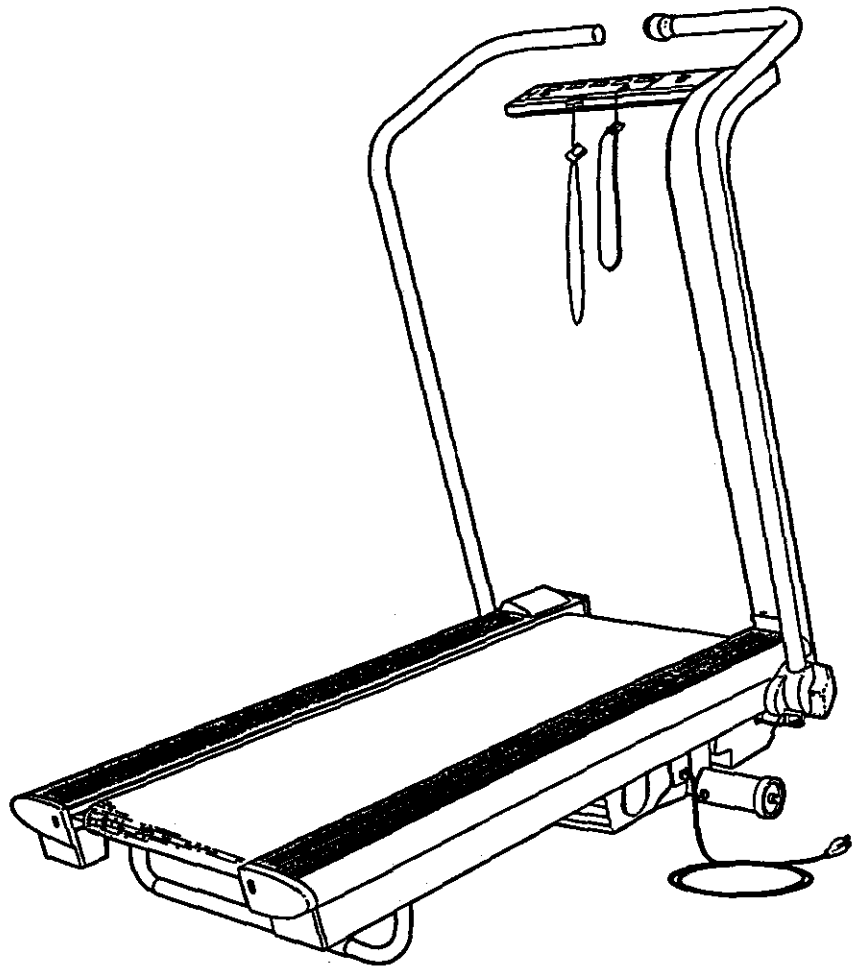

SEARS, ROEBUCK AND CO., HOFFMAN ESTATES, IL 60179

FULL 90 DAY WARRANTY

For 90 days from the date of purchase, when proper assembly and maintenance procedures detailed in the Owner's Manual are followed, SEARS will, free of charge, repair or replace and install a replacement part for any defective part, when this treadmill is used in a normal manner.

This warranty does not apply when this treadmill is used for commercial or rental purposes.

SERVICE IS AVAILABLE SIMPLY BY CONTACTING YOUR NEAREST SEARS SERVICE CENTER/DEPARTMENT IN THE UNITED STATES.

This warranty gives you specific legal rights, and you may also have other rights which vary from state to state.

**SEARS, ROEBUCK AND CO., DEPT. 817WA,
3333 BEVERLY ROAD, HOFFMAN ESTATES, IL 60179**

PRO-FORM[®] PLUS
CROSS  **WALK**[™]
 DUAL MOTION CROSS TRAINER EXPANDED RUNNING SURFACE

TABLE OF CONTENTS

IMPORTANT SAFETY PRECAUTIONS	4
BEFORE YOU BEGIN	5
ASSEMBLY	6
OPERATION AND ADJUSTMENT	7
TROUBLE-SHOOTING	10
CONDITIONING GUIDELINES	12
PART LIST	14
EXPLODED DRAWING	15
ORDERING REPLACEMENT PARTS	Back Cover

▲ WARNING: Before beginning this or any exercise program, consult your physician. This is especially important for persons over the age of 35 or persons with pre-existing health problems. Read all instructions before using. SEARS assumes no responsibility for personal injury or property damage sustained by or through the use of this product.

IMPORTANT SAFETY PRECAUTIONS

▲ WARNING: To reduce the risk of burns, fire, electric shock or injury to persons, read the following important safety precautions and information before operating the treadmill.

1. Position the treadmill on a level surface, with at least 8 feet of clearance behind the treadmill. Do not place the treadmill near water, outdoors or on a surface that blocks any air openings. Do not operate where aerosol products are used or where oxygen is being administered.
2. When connecting the power cord (see OPERATION AND ADJUSTMENT on page 7), plug the power cord directly into a grounded circuit capable of carrying 12 or more amps. No other appliance should be on the same circuit. Keep the power cord away from heated surfaces. If an extension cord is needed, use only a 14-gauge general-purpose cord of five feet or less in length with a three-wire conductor.
3. Never move the walking belt while the power is turned off. Do not operate the treadmill if the power cord or plug is damaged, or if the treadmill is not working properly. (See BEFORE YOU BEGIN on page 5 if the treadmill is not working properly.)
4. Wear appropriate exercise clothing when using the treadmill; do not wear loose clothing that could become caught in the treadmill. *Always wear athletic shoes; never use the treadmill with bare feet, wearing only stockings or in sandals.* Athletic support clothes are recommended for both men and women.
5. The pulse earclip is not a medical device. Various factors, including the user's movement while exercising, may affect the accuracy of heart rate readings. The earclip is intended only as an exercise aid in determining heart rate trends in general.
6. Never start the treadmill while you are standing on the walking belt. Always hold the dual action arms when exercising on the treadmill.
7. Never allow more than one person on the treadmill at a time. The treadmill should not be used by persons weighing more than 250 pounds.
8. Keep small children away from the treadmill at all times. Never leave the treadmill unattended while it is running. Always turn the power off when the treadmill is not in use.
9. Never drop or insert any object into any opening.
10. To reduce the possibility of overheating, do not operate the treadmill continuously for longer than 1 hour.
11. The treadmill is capable of high speeds. Adjust the speed slowly to avoid sudden jumps in speed.
12. Use the treadmill only as described in this manual.
13. Always unplug the power cord before performing the maintenance and adjustment procedures described in this manual. Never remove the motor hood unless instructed to do so by an authorized service representative. Servicing other than the procedures in this manual should be performed by an authorized service representative only.

4 SAVE THESE INSTRUCTIONS

BEFORE YOU BEGIN

Thank you for selecting the PROFORM® CROSSWALK™ PLUS treadmill. The CROSSWALK PLUS treadmill blends advanced technology with innovative design to let you enjoy an excellent form of cardiovascular exercise in the convenience and privacy of your home.

For your safety and benefit, read this manual carefully before using the treadmill. If you have additional questions, please call our Customer Service Department toll-free at 1-800-999-3756, Monday through Friday, 6 a.m. until 6 p.m. Mountain Time (excluding holidays). To help us assist you, please note the product model number and serial number before calling. The model number of the treadmill is 831.297350. The serial number can be found on a decal attached to the treadmill (see the front cover of this manual for the location).

Before reading further, please review the drawing below and familiarize yourself with the parts that are labeled.

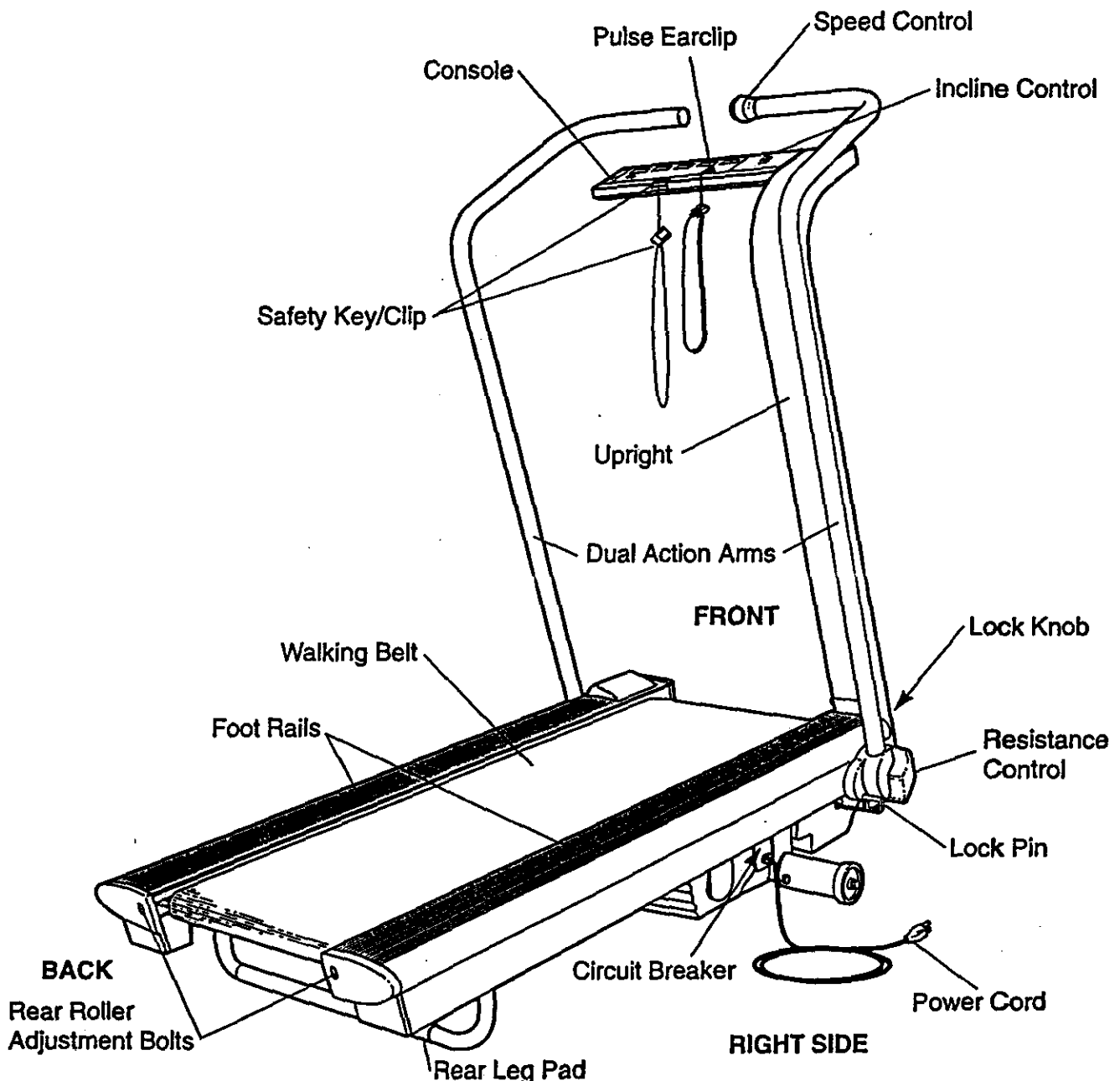

Note: The rear leg pad may mark some types of linoleum. Mild household cleaning agents will remove any marks.

ASSEMBLY

The treadmill is delivered in the compact stowaway position. Set the treadmill in a cleared area and remove all packing materials. Do not dispose of the packing materials until assembly is completed.

1. To convert the treadmill to the operating position, first raise the Upright (15) to a vertical position. Insert the Lock Knob (24), with the Lock Knob Washer (23), into the Upright and turn the Knob clockwise until tight.

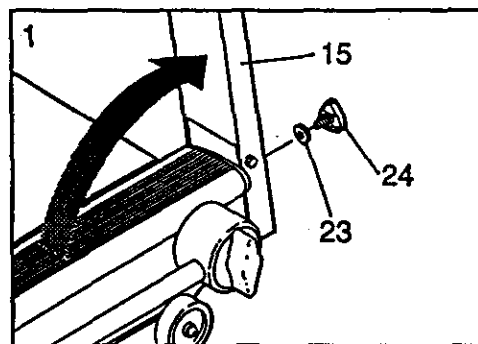

2. Raise the Right Dual Action Arm (14) to a vertical position. Insert a Lock Pin (19) through the Dual Action Arm and into the hole in the treadmill Frame (56). Firmly tighten the Resistance Control (27). The Dual Action Arm is now in the lock position. (See OPERATING THE DUAL ACTION ARMS on page 9.) Insert a Lock Pin into the Left Dual Action Arm (not shown) in the same manner. Make sure the Lock Pins are fully inserted.

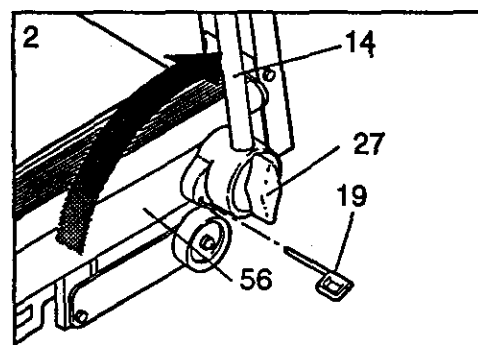

3. Remove the paper backing from the Wrench Clip (70). Press the Wrench Clip onto the Right Rear Endcap (62) in the indicated location. Press the Allen Wrench (69) into the Wrench Clip.

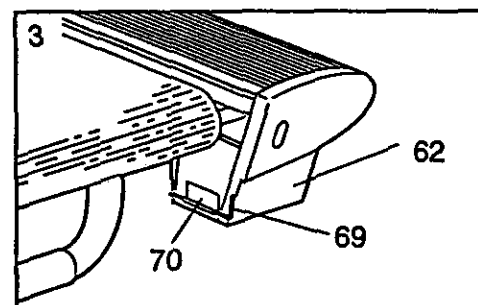

4. Slide the metal Clothes Clip onto the Pulse Earclip in the indicated location. The use of the Pulse Earclip is explained in the MOTIVATIONAL FITNESS MONITOR section on page 9.

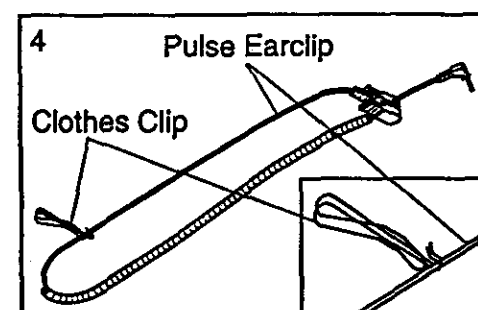

Make sure that all parts are tightened before using the treadmill. **Note: To protect the floor, a covering should be placed under the treadmill.**

OPERATION AND ADJUSTMENT

PLUGGING IN THE POWER CORD

This product must be grounded. If it should malfunction or break down, grounding provides a path of least resistance for electric current to reduce the risk of electric shock. This product is equipped with a cord having an equipment-grounding conductor and a grounding plug. Plug the power cord into an appropriate outlet that is properly installed and grounded in accordance with all local codes and ordinances.

⚠ DANGER: Improper connection of the equipment-grounding conductor can result in a risk of electric shock. Check with a qualified electrician or serviceman if you are in doubt as to whether the product is properly grounded. Do not modify the plug provided with the product—if it will not fit the outlet, have a proper outlet installed by a qualified electrician.

This product is for use on a nominal 120-volt circuit, and has a grounding plug that looks like the plug illustrated in Drawing 1. A temporary adapter that looks like the adapter illustrated in Drawing 2 may be used to connect this plug to a 2-pole receptacle as shown in Drawing 2 if a properly grounded outlet is not available. The temporary adapter should be used only until a properly grounded outlet (Drawing 1) can be installed by a qualified electrician. The green colored rigid ear, lug, or the like extending from the adapter must be connected to a permanent ground such as a properly grounded outlet box cover. Whenever the adapter is used it must be held in place by a metal screw.

Some 2-pole receptacle outlet box covers are not grounded. Contact a qualified electrician to determine if the outlet box cover is grounded before using an adapter.

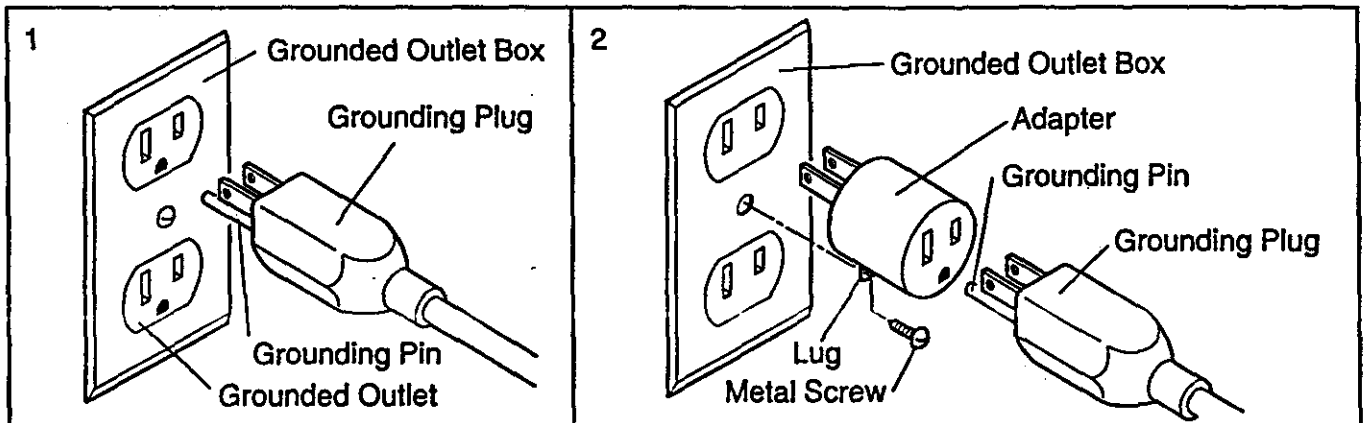

APPLYING SILICONE LUBRICANT

To reduce the friction of the walking belt and minimize wear, a non-oil-, non-petroleum-base silicone lubricant must be applied to the walking platform before the CROSSWALK PLUS is used. **WITH THE POWER CORD UNPLUGGED,** lift each side of the walking belt and spray lubricant generously onto the indicated area. Reapply lubricant after every ten hours of use, or whenever performance decreases. Lubricant is available at hardware and automotive stores. UniSport™ spray is recommended.

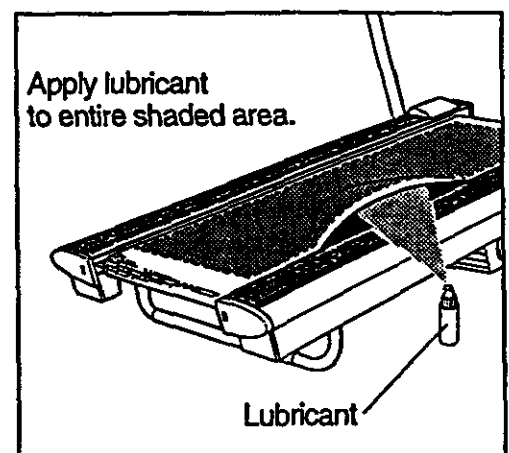
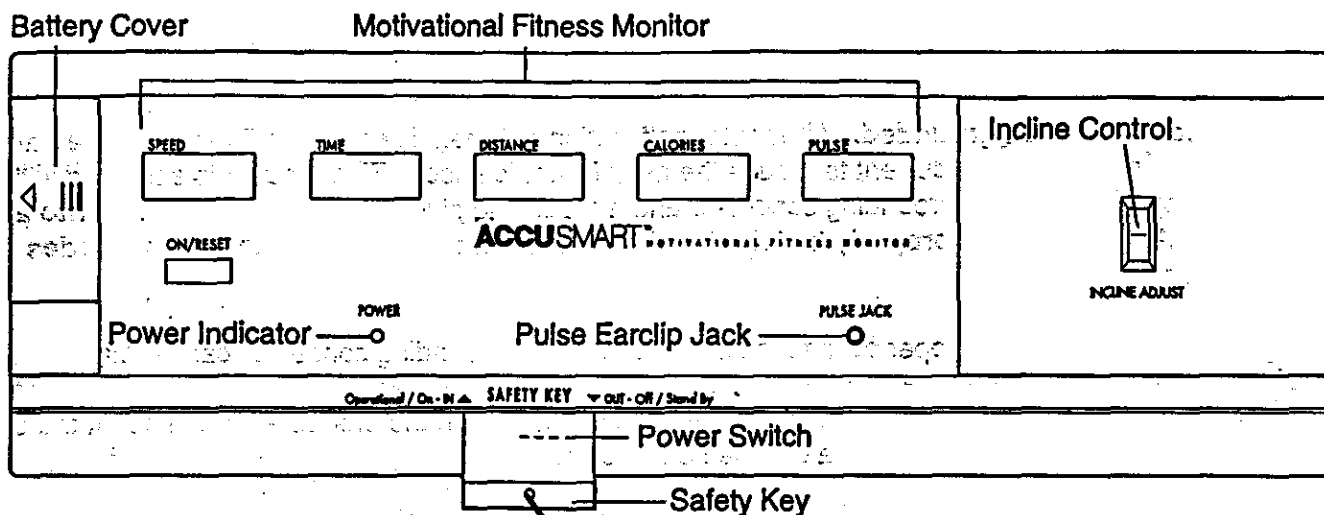
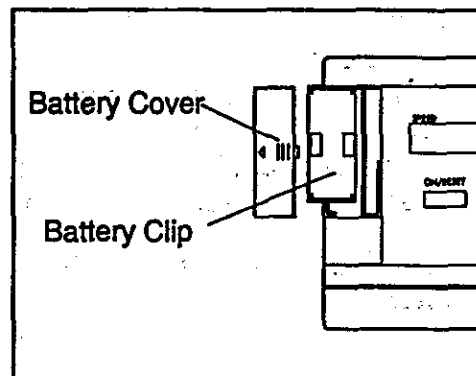

DIAGRAM OF THE CONSOLE



INSTALLING BATTERIES

The motivational fitness monitor requires two "AA" batteries (not included); alkaline batteries are recommended. Slide the battery cover open. Remove the battery clip from the console. Find the markings inside the battery clip showing which direction the batteries should be turned. Press the batteries into the battery clip. Replace the battery clip in the console and close the battery cover. **Note:** If there is a sheet of protective plastic on the face of the console, peel it off before operating the console.



TURNING ON THE POWER.

Step onto the foot rails of the treadmill. Locate the clip attached by a cord to the safety key, and slide the clip onto the waistband of your clothing.

CAUTION: Do not stand on the walking belt while turning on the power. Always wear the clip while operating the treadmill; if you fall, the safety key will be pulled from the power switch, instantly turning off the power.

Insert the safety key into the power switch. The power indicator will light. The five displays of the motivational fitness monitor will not appear until the ON/RESET button is pressed, or the walking belt begins to move (see CONTROLLING THE SPEED below). **Note:** If batteries were just installed, the five displays will already appear.

CONTROLLING THE SPEED

To start the walking belt, first turn the speed control down until the ridge on the control is at "RESET." Then, turn the control slowly until the walking belt begins to move at slow speed.

CAUTION: After the speed control is turned, there will be a pause before the walking belt begins to move. Adjust the speed slowly until you are familiar with the operation of the treadmill.

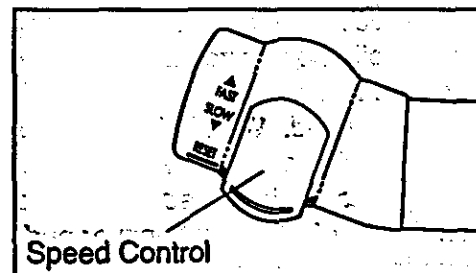

Carefully step onto the walking belt and begin exercising. Change the speed of the walking belt as desired by turning the speed control. To stop the walking belt, turn the control to "RESET."

CHANGING THE INCLINE

To vary the intensity of your exercise, the incline of the treadmill can be changed using the incline control on the right side of the console. To increase the incline, press the end of the switch farthest from you. To decrease the incline, press the end of the switch closest you.

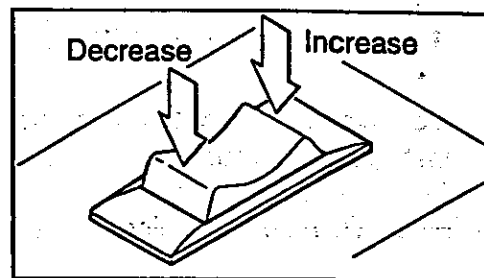

OPERATING THE DUAL ACTION ARMS

The dual action arms can be used in either the stationary position or the dual motion position. To use the dual action arms in the stationary position, insert a lock pin through the base of each arm and into the treadmill frame. Firmly tighten the resistance control. Make sure that the pins are fully inserted. To use the dual action arms in the dual motion position, first make sure the resistance control is tightened. Remove the lock pins from the arms and the upright, and store them in a secure place. In the dual motion position, you can move the arms forward and back as you walk or run, exercising your arms, back and shoulders for a total body workout. To tailor the intensity of your exercise, the resistance of the arms can be changed. To increase the resistance, turn the resistance control clockwise; to decrease the resistance, turn the control counterclockwise.

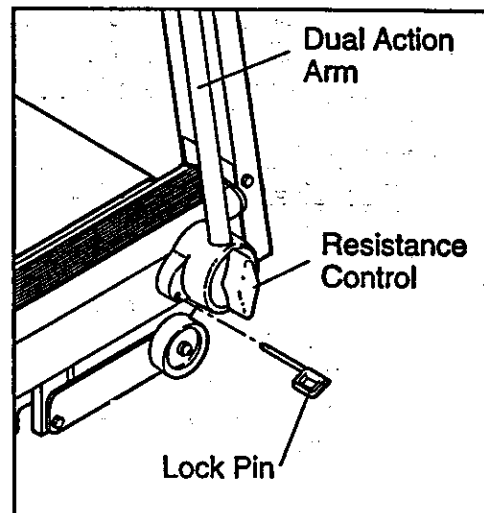

MOTIVATIONAL FITNESS MONITOR

The five displays of the motivational fitness monitor provide continuous exercise feedback. The displays can be reset by pressing the ON/RESET button. The five displays are described below:

SPEED—This display shows the current speed of the walking belt.

TIME—This display shows the elapsed time. Note: When the walking belt is stopped, the TIME display will go into a pause mode after a few seconds.

DISTANCE—This display shows the total distance that you have walked or run.

CALORIES—This display shows the approximate number of nutritional Calories that you have burned.

PULSE—This display shows your heart rate. Plug the pulse earclip into the jack on the console, and attach the earclip to your left ear lobe. Slide the metal clothes clip on the earclip wire onto your collar. After a few seconds, your heart rate will be displayed. If your heart rate is not displayed, rub your ear lobe and reposition the earclip. It may be helpful to stand still while measuring your heart rate.

Note: If the walking belt is stopped and remains stationary for about four minutes, the five displays of the motivational fitness monitor will be reset and will darken, although the power will remain on. The five displays will appear again when the ON/RESET button is pressed, or the walking belt is restarted.

TURNING OFF THE POWER

To turn off the power, remove the safety key from the console. The power indicator will darken. Store the safety key in a secure location.

TROUBLE-SHOOTING

Most treadmill problems can be solved by following the simple steps below. Find the symptom that applies to your treadmill and follow the steps listed. If further assistance is needed, please call our Customer Service Department toll-free at 1-800-999-3756, Monday through Friday, 6 a.m. until 6 p.m. Mountain Time (excluding holidays).

1. SYMPTOM: THE POWER DOES NOT TURN ON

- a. Make sure that the power cord is plugged into a properly grounded outlet. (See OPERATION AND ADJUSTMENT on page 7.) If an extension cord is needed, use only a 14-gauge general-purpose cord of five feet or less in length.
- b. After the power cord has been plugged in, make sure that the safety key is fully inserted into the console. Various indicators on the console should light. (See OPERATION AND ADJUSTMENT on page 7.)
- c. Check the circuit breaker located on the treadmill frame near the power cord. If the switch protrudes as shown, the circuit breaker has tripped. To reset the circuit breaker, wait for five minutes and then press the switch back in.

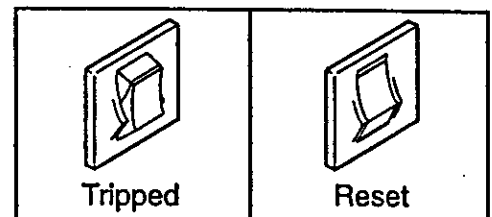

2. SYMPTOM: THE POWER TURNS OFF DURING USE

- a. Check the circuit breaker located on the treadmill frame near the power cord. If the circuit breaker has tripped, the switch will protrude. (See the drawing above.) To reset the circuit breaker, wait for five minutes and then press the switch back in.
- b. Make sure that the power cord is plugged in.
- c. Remove the safety key from the console. Reinsert the safety key fully into the console. Various indicators on the console should light.

3. SYMPTOM: THE PULSE EARCLIP DOES NOT FUNCTION PROPERLY

- a. Make sure that the pulse earclip is plugged fully into the jack on the console. Rub your left ear lobe and reposition the earclip. Attach the clothes clip to your collar.
- b. Stand still while measuring your pulse.
- c. The pulse earclip may need to be cleaned. Press the earclip open, and find the two clear circles inside the earclip. Wipe the two clear circles using a cotton swab saturated with denatured alcohol.

⚠ WARNING: The pulse earclip is not a medical device. Various factors, including the user's movement while exercising, may affect the accuracy of heart rate readings. The earclip is intended only as an exercise aid in determining heart rate trends in general.

4. SYMPTOM: THE MOTIVATIONAL FITNESS MONITOR DOES NOT FUNCTION PROPERLY

- a. Check the batteries in the console. (See INSTALLING BATTERIES on page 8.) Most problems are the result of drained batteries.

5: SYMPTOM: THE WALKING BELT SLOWS WHEN WALKED ON

- a. Silicone lubricant must be applied to the walking platform before the CROSSWALK PLUS is used. Lubricant should be reapplied after every 10 hours of use, and whenever a decrease in performance is noticed. (See OPERATION AND ADJUSTMENT on page 7 for application instructions.) Uni-Sport silicone spray is recommended. **CAUTION: ALWAYS UNPLUG THE POWER CORD WHEN APPLYING LUBRICANT.**
- b. If an extension cord is needed, use only a 14-gauge general-purpose cord of five feet or less in length.
- c. If the walking belt is overtightened, treadmill performance may decrease and the walking belt may be permanently damaged. Remove the safety key and **UNPLUG THE POWER CORD**. Using the allen wrench, turn both rear roller adjustment bolts counterclockwise, 1/4 of a turn. When the walking belt is properly tightened, you should be able to lift each side of the walking belt 3-4 inches off the walking platform. The center of the walking belt should just touch the walking platform. Be careful to keep the walking belt centered. Plug in the power cord, insert the safety key and run the treadmill for a few minutes. Repeat until the walking belt is properly tightened.

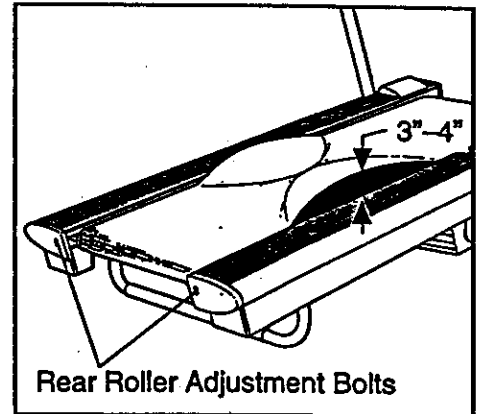

6. SYMPTOM: THE WALKING BELT IS OFF-CENTER OR SLIPS WHEN WALKED ON

- a. If the walking belt has shifted to the left, first remove the safety key and **UNPLUG THE POWER CORD**. Using the allen wrench, turn the left rear roller adjustment bolt clockwise, and the right bolt counterclockwise, 1/4 of a turn each. Be careful not to overtighten the walking belt. Plug in the power cord, insert the safety key and run the treadmill for a few minutes. Repeat until the walking belt is centered.
- b. If the walking belt has shifted to the right, first remove the safety key and **UNPLUG THE POWER CORD**. Using the allen wrench, turn the left rear roller adjustment bolt counterclockwise, and the right bolt clockwise, 1/4 of a turn each. Be careful not to overtighten the walking belt. Plug in the power cord, insert the safety key and run the treadmill for a few minutes. Repeat until the walking belt is centered.
- c. If the walking belt slips when walked on, first remove the safety key and **UNPLUG THE POWER CORD**. Using the allen wrench, turn both rear roller adjustment bolts clockwise, 1/4 of a turn. When the walking belt is correctly tightened, you should be able to lift each side of the walking belt 3-4 inches off the walking platform. The center of the walking belt should just touch the walking platform. Be careful to keep the walking belt centered. Plug in the power cord, insert the safety key and run the treadmill for a few minutes. Repeat until the walking belt is properly tightened.

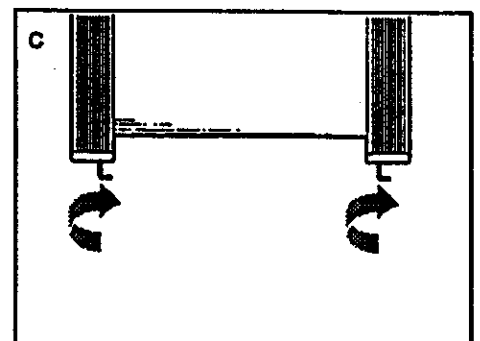
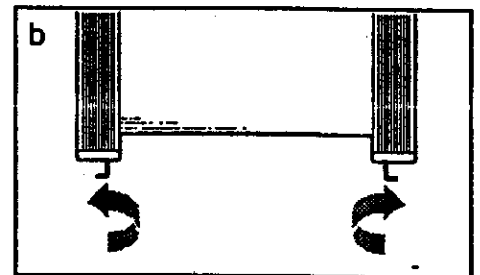
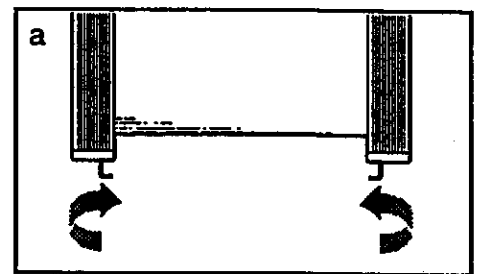

CONDITIONING GUIDELINES

The following guidelines will help you to plan your exercise program. Remember that proper nutrition and adequate rest are essential for successful results.

⚠ WARNING: Before beginning this or any exercise program, consult your physician. This is especially important for individuals over the age of 35 or individuals with pre-existing health problems.

EXERCISE INTENSITY

To maximize the benefits of exercising, it is important to exercise with the proper intensity. The proper intensity level can be found by using your heart rate as a guide. For effective aerobic exercise, your heart rate should be maintained at a level between 70% and 85% of your maximum heart rate as you exercise. This is known as your training zone. You can find your training zone in the table below.

AGE	UNCONDITIONED TRAINING ZONE (BEATS/MIN)	CONDITIONED TRAINING ZONE (BEATS/MIN)	AGE	UNCONDITIONED TRAINING ZONE (BEATS/MIN)	CONDITIONED TRAINING ZONE (BEATS/MIN)
20	138-167	133-162	55	127-155	122-149
25	136-166	132-160	60	126-153	121-147
30	135-164	130-158	65	125-151	119-145
35	134-162	129-156	70	123-150	118-144
40	132-161	127-155	75	122-147	117-142
45	131-159	125-153	80	120-146	115-140
50	129-156	124-150	85	118-144	114-139

During the first few months of your exercise program, keep your heart rate near the low end of your training zone as you exercise. After a few months of regular exercise, your heart rate can be increased gradually until it is near the middle of your training zone as you exercise. You can measure your heart rate using the pulse mode of the console. Exercise for at least four minutes, and then measure your heart rate immediately. If your heart rate is too high, decrease the intensity of your exercise. If your heart rate is too low, increase the intensity of your exercise.

⚠ WARNING: The pulse earclip is not a medical device. Various factors, including your movement during exercise, may affect the accuracy of heart rate readings. The earclip is intended only as an exercise aid in determining heart rate trends in general.

WORKOUT GUIDELINES

Each workout should consist of three basic parts: a warm-up, 20 to 30 minutes of training zone exercise, and a cool-down. Warming up prepares the body for exercise by increasing circulation, delivering more oxygen to the muscles and raising the body temperature. Begin each workout with 5 to 10 minutes of stretching and light exercise to warm up. Then, increase the intensity of your exercise to raise your heart rate to your training zone for 20 to 30 minutes. Breathe regularly and deeply as you exercise—never hold your breath. Finish each workout with 5 to 10 minutes of stretching to cool down. This will increase the flexibility of your muscles as well as help to decrease soreness and other post-exercise problems.

To maintain or improve your condition, complete three workouts each week, with at least one day of rest between workouts. After a few months of regular exercise, you may complete up to five workouts each week, if desired. The key to success is CONSISTENCY.

SUGGESTED STRETCHES

The following stretches can provide a good warm-up or cool-down. Correct form for each stretch is shown in the drawings below. Move slowly as you stretch—never bounce.

TOE TOUCH STRETCH

Stand with your knees bent slightly and slowly bend forward from your hips. Allow your back and shoulders to relax as you reach down toward your toes as far as possible. Hold for 15 counts, then relax. Repeat 3 times.

Stretches: Hamstrings, back of knees and back.

HAMSTRING STRETCH

Sit with one leg extended. Bring the sole of the opposite foot toward you and rest it against the inner thigh of your extended leg. Reach toward your toes as far as possible. Hold for 15 counts, then relax. Repeat 3 times for both legs.

Stretches: Hamstrings, lower back and groin.

CALF/ACHILLES STRETCH

With one leg in front of the other, reach forward and place your hands against a wall. Keep your back leg straight and your back foot flat on the floor. Bend your front leg, lean forward and move your hips toward the wall. Hold for 15 counts, then relax. Repeat 3 times for both legs. To cause further stretching of the achilles tendons, bend your back leg as well.

Stretches: Calves, achilles tendons and ankles.

QUADRICEPS STRETCH

With one hand against a wall for balance, reach back and grasp one foot with your other hand. Bring your heel as close to your buttocks as possible. Hold for 15 counts, then relax. Repeat 3 times for both legs.

Stretches: Quadriceps and hip muscles.

INNER THIGH STRETCH

Sit with the soles of your feet together and your knees outward. Pull your feet toward your groin area as far as possible. Hold for 15 counts, then relax. Repeat 3 times.

Stretches: Quadriceps and hip muscles.

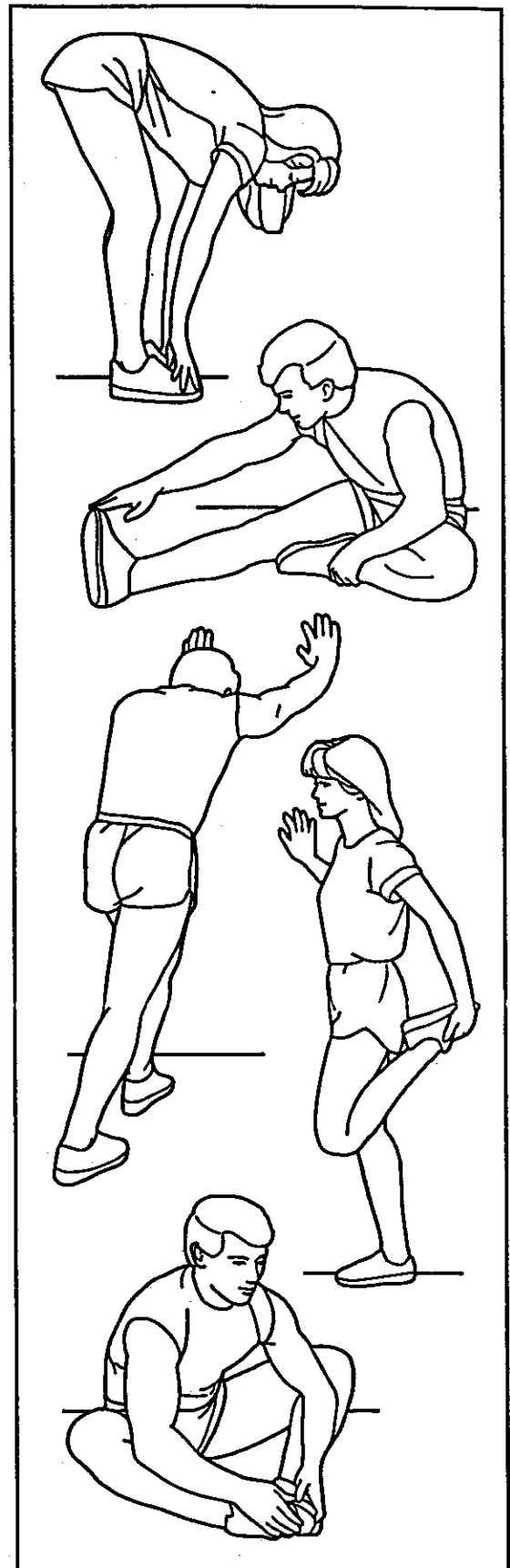

PART LIST—Model No. 831.297350

R794A

Key No.	Part No.	Qty.	Description	Key No.	Part No.	Qty.	Description
1	120448	1	Left Dual Action Arm/Housing	50	013162	16	Belly Pan Screw
2	112589	1	Pulse Earclip/Clothes Clip	51	116677	1	Incline Leg
3	114265	1	Safety Key/Clip	52	119375	2	Incline Motor Bolt
4	120436	1	Console	53	114270	1	Lift Motor Spacer
5	108404	27	Screw	54	013322	4	Rear Endcap Screw
6	118149	1	Power Switch Wire	55	115523	1	Incline Motor
7	031108	1	Incline Control Switch	56	NSP	1	Frame
8	116569	1	Speed Control	57	120451	1	Front Safety Cover
9	118156	1	Speed Control Wire	58	120845	1	Back Safety Cover
10	013028	1	Speed Knob Screw	59	120324	1	Walking Belt
11	118140	1	Upright Endcap	60	116762	1	Right Foot Rail
12	118150	1	Lift Wire	61	110407	1	Rear Leg Pad
13	109520	1	6" Cable Loom	62	116601	1	Right Rear Endcap
14	120449	1	Right Dual Action Arm/Housing	63	016057	1	8" Cable Tie
15	116671	1	Upright	64	016029	2	4" Cable Tie
16	116599	1	Front Left Endcap	65	105444	2	Rear Roller Adj. Bolt
17	120847	1	Front Roller/Pulley	66	118049	1	Incline Motor Bracket
18	103643	1	12" Cable Loom	67	108277	1	Pulley/Flywheel/Fan
19	116675	2	Lock Pin	68	119651	1	Choke Guard
20	014127	3	Roller Adjustment Washer	69	045010	1	Allen Wrench
21	013186	1	Front Roller Adj. Bolt	70	016028	2	Wrench Clip
22	116687	1	Left Housing	71	109788	1	Rear Roller
23	014156	1	Upright Knob Washer	72	116600	1	Left Rear Endcap
24	017088	1	Upright Knob	73	120443	2	Foot Rail Mounting Track
25	111869	1	Cage Nut	74	100691	8	Platform Screw
26	013485	1	Hinge Bolt	75	120326	1	Walking Platform
27	118089	1	Resistance Control	76	118571	2	Platform Shim
28	106896	2	Thrust Bearing	77	120452	1	Left Foot Rail
29	102973	4	Thrust Washer	78	116681	1	Resistance Bolt
30	120450	2	Leather/Metal Friction Plate	79	118088	1	Resistance Housing Cap
31	116673	1	Left Friction Plate	80	013443	1	Motor Tension Bolt
32	118148	1	Belt Guide	81	116672	1	Right Friction Plate
33	115872	1	Strain Relief	82	120434	1	Motor Mounting Bracket
34	114005	1	Dual Action Arm Endcap	83	118016	1	Belt
35	116649	1	Front Right Endcap	84	100994	2	Motor Bolt
36	117941	1	Electronics Mounting Bracket	85	120432	1	Motor
37	109382	1	Circuit Breaker	86	118152	1	Reed Switch Extension Wire
38	019084	1	Power Cord Grommet	87	118153	1	Reed Switch Wire
39	031229	1	Power Cord	88	016055	4	Wire Clip
40	109786	1	Controller	89	013300	1	Long Safety Cover Screw
41	012056	2	Front Wheel Nut	90	105477	2	Motor Nut
42	052014	2	Front Wheel	91	107503	1	Motor Swivel Bolt
43	117806	2	Wheel Bolt	92	014087	5	Flat Washer
44	116688	1	Right Housing	#	112083	1	8" Blue Jumper Wire, Female
45	013547	2	Incline Leg Bolt	#	118204	1	8" Blue Jumper Wire, Male/Female
46	012149	7	Lock Nut	#	118201	1	8" Red Jumper Wire, Male/Female
47	015071	4	Plastic Stand-Off	#	101899	1	4" White Jumper Wire, Female
48	111205	1	Power Board	#	016017	2	Tie Block
49	031238	1	Choke	#	118058	1	Owner's Manual

14 Note: "#" indicates a non-illustrated part. Specifications are subject to change without notice. See the back cover for information about ordering replacement parts.

EXPLODED DRAWING—Model No. 831.297350

R794A

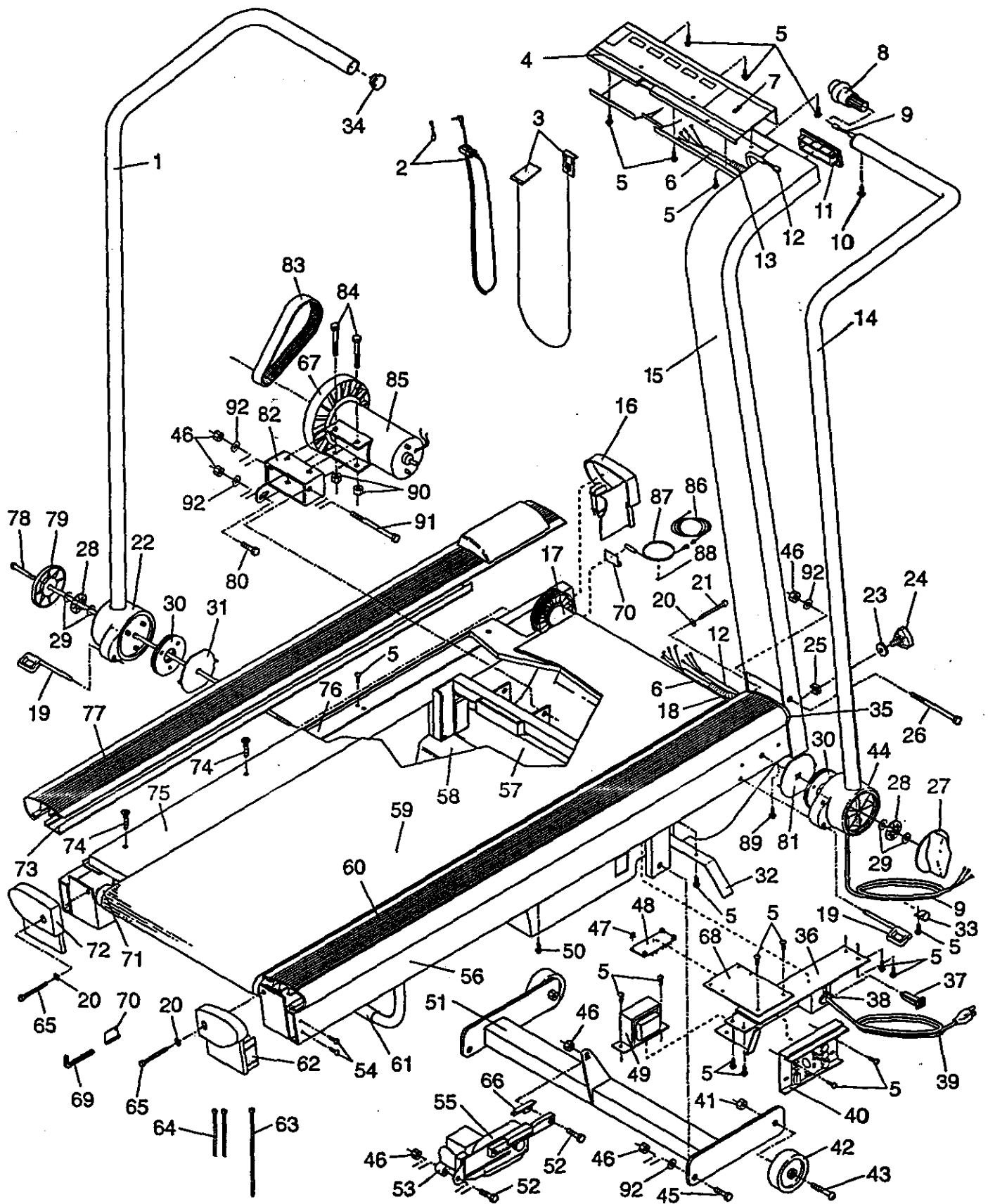

ORDERING REPLACEMENT PARTS

Each TREADMILL has its own MODEL NUMBER. Always mention this MODEL NUMBER when requesting service or repair parts for your TREADMILL.

All parts listed herein can be ordered through SEARS, ROEBUCK AND CO. SERVICE CENTERS and most SEARS RETAIL STORES. If parts you need are not stocked locally, your order will be transmitted to a SEARS PARTS DISTRIBUTION CENTER for handling.

WHEN ORDERING REPAIR PARTS, ALWAYS GIVE THE FOLLOWING INFORMATION:

1. The MODEL NUMBER of the product (831.297350).
2. The NAME of the product (PROFORM® CROSSWALK™ PLUS treadmill).
3. The PART NUMBER of the part(s) from page 14 of this owner's manual.
4. The DESCRIPTION of the part(s) from page 14 of this owner's manual.

Your SEARS TREADMILL has added value when you consider that SEARS has service units nationwide, staffed with SEARS trained technicians specifically trained on SEARS products, having the parts, tools and equipment to ensure that we meet our pledge to you: "We service what we sell."

Should you ever need repair service or parts, call toll free:

For repair service: 1-800-4-REPAIR (1-800-473-7247)

For repair parts: 1-800-FON-PART (1-800-366-7278)