

Lifestyler®

8.0 MPH

0-8 MPH • 1.5 HP • ADJUSTABLE INCLINE

OWNER'S MANUAL

SEARS®

Model No. 831.297420

Serial No. _____

The serial number can be found in the location shown below. Write the serial number in the space above.

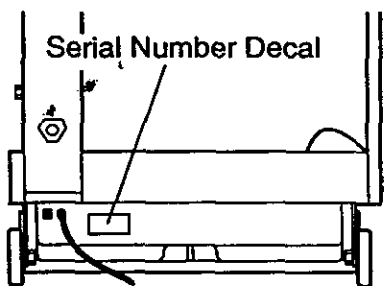

▲ CAUTION!:

Read all safety precautions and instructions in this manual before using this equipment. Keep this manual in a safe place for future reference.

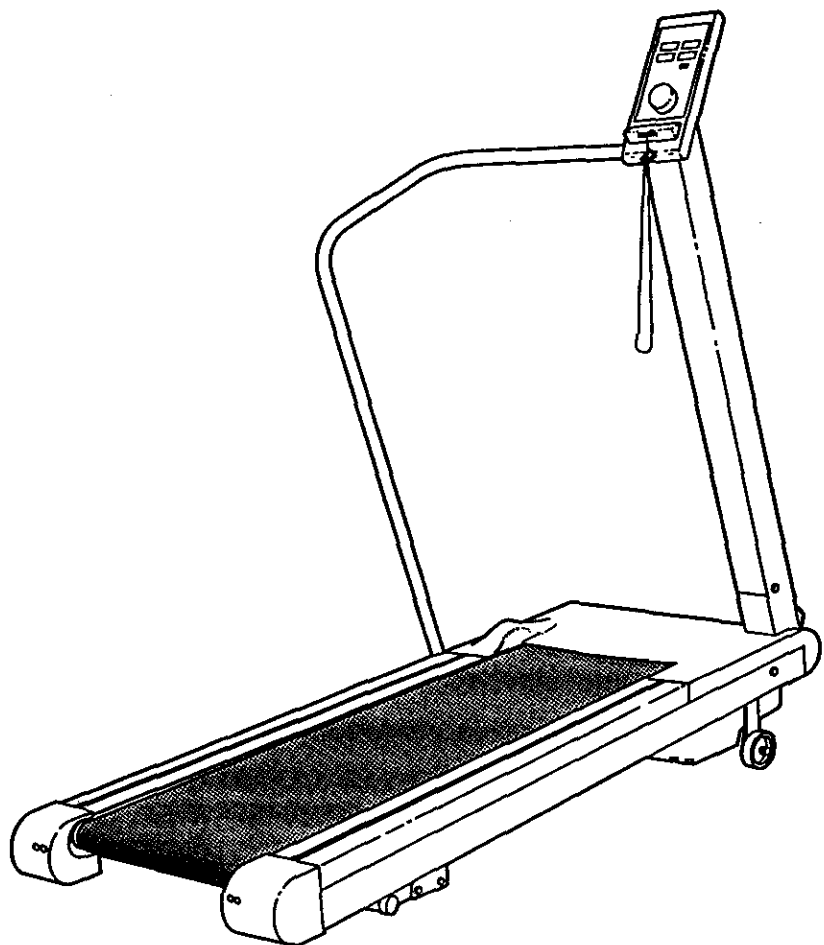

SEARS, ROEBUCK AND CO., HOFFMAN ESTATES, IL 60179

FULL 90 DAY WARRANTY

For 90 days from the date of purchase, when proper assembly and maintenance procedures detailed in the Owner's Manual are followed, SEARS will, free of charge, repair or replace and install a replacement part for any defective part, when this treadmill is used in a normal manner.

This warranty does not apply when this treadmill is used for commercial or rental purposes.

SERVICE IS AVAILABLE SIMPLY BY CONTACTING YOUR NEAREST SEARS SERVICE CENTER/DEPARTMENT IN THE UNITED STATES.

This warranty gives you specific legal rights, and you may also have other rights which vary from state to state.

**SEARS, ROEBUCK AND CO., DEPT. 817WA,
HOFFMAN ESTATES, IL 60179**

Lifestyler®

8.0 MPH

0-8 MPH • 1.5 HP • ADJUSTABLE INCLINE

TABLE OF CONTENTS

IMPORTANT SAFETY PRECAUTIONS	4
BEFORE YOU BEGIN	5
ASSEMBLY	6
OPERATION AND ADJUSTMENT	7
TROUBLE-SHOOTING AND STORAGE	10
CONDITIONING GUIDELINES	12
PART LIST	14
EXPLODED DRAWING	15
ORDERING REPLACEMENT PARTS	Back Cover

⚠ WARNING: Before beginning this or any exercise program, consult your physician. This is especially important for persons over the age of 35 or persons with pre-existing health problems. Read all instructions before using. SEARS assumes no responsibility for personal injury or property damage sustained by or through the use of this product.

IMPORTANT SAFETY PRECAUTIONS

▲ WARNING: To reduce the risk of burns, fire, electric shock or injury to persons, read the following important safety precautions and information before operating the treadmill.

1. Position the treadmill on a level surface, with at least 8 feet of clearance behind the treadmill. Do not place the treadmill near water, outdoors or on a surface that blocks any air opening. Do not operate where aerosol products are used or where oxygen is being administered.
2. When connecting the power cord (see OPERATION AND ADJUSTMENT on page 7), plug the power cord directly into a grounded circuit capable of carrying 12 or more amps. No other appliances should be on the same circuit. Keep the power cord away from heated surfaces. If an extension cord is needed, use only a 14-gauge general-purpose cord of five feet or less in length with a three-wire conductor.
3. Never move the walking belt while the power is turned off. Do not operate the treadmill if the power cord or plug is damaged, or if the treadmill is not working properly. (See BEFORE YOU BEGIN on page 5 if the treadmill is not working properly.)
4. The roller guards must be 1/8 inch from the rear roller. Turn the power off and adjust the roller guards, if necessary.
5. Wear appropriate exercise attire when using the treadmill. Do not wear loose clothing that could become caught in the treadmill. *Always wear running shoes. Never use the treadmill with bare feet, wearing only stockings or in sandals.* Athletic support clothes are recommended for both men and women.
6. Never allow more than one person on the treadmill at a time. The treadmill should be used only by persons weighing 250 pounds or less.
7. Never start the treadmill while you are standing on the walking belt. Always hold the handrail when exercising on the treadmill.
8. Keep small children away from the treadmill at all times. Never leave the treadmill unattended while it is running. Always remove the safety key when the treadmill is not in use.
9. Never drop or insert any object into any opening.
10. To reduce the possibility of overheating, do not operate the treadmill continuously for longer than 1 hour.
11. The treadmill is capable of high speeds. Adjust the speed slowly to avoid sudden jumps in speed.
12. Use the treadmill only as described in this manual.
13. Always unplug the power cord before performing the maintenance and adjustment procedures described in this manual. Never remove the motor hood unless instructed to do so by an authorized service representative. Servicing other than the procedures in this manual should be performed by an authorized service representative only.

4 SAVE THESE INSTRUCTIONS

BEFORE YOU BEGIN

Thank you for selecting the SEARS LIFESTYLER® 8.0 MPH treadmill. The LIFESTYLER 8.0 MPH treadmill blends advanced technology with innovative design to let you enjoy an excellent form of cardiovascular exercise in the convenience and privacy of your home.

For your safety and benefit, read this manual carefully before using the treadmill. If you have additional questions, please call our Customer Service Department toll-free at **1-800-999-3756**, Monday through Friday, 6 a.m. until 6 p.m. Mountain Time (excluding holidays). To help us assist you, please note the product model number and serial number before calling. The model number of the treadmill is 831.297420. The serial number can be found on a decal attached to the treadmill (see the front cover of this manual for the location).

Before reading further, please review the drawing below and familiarize yourself with the parts that are labeled.

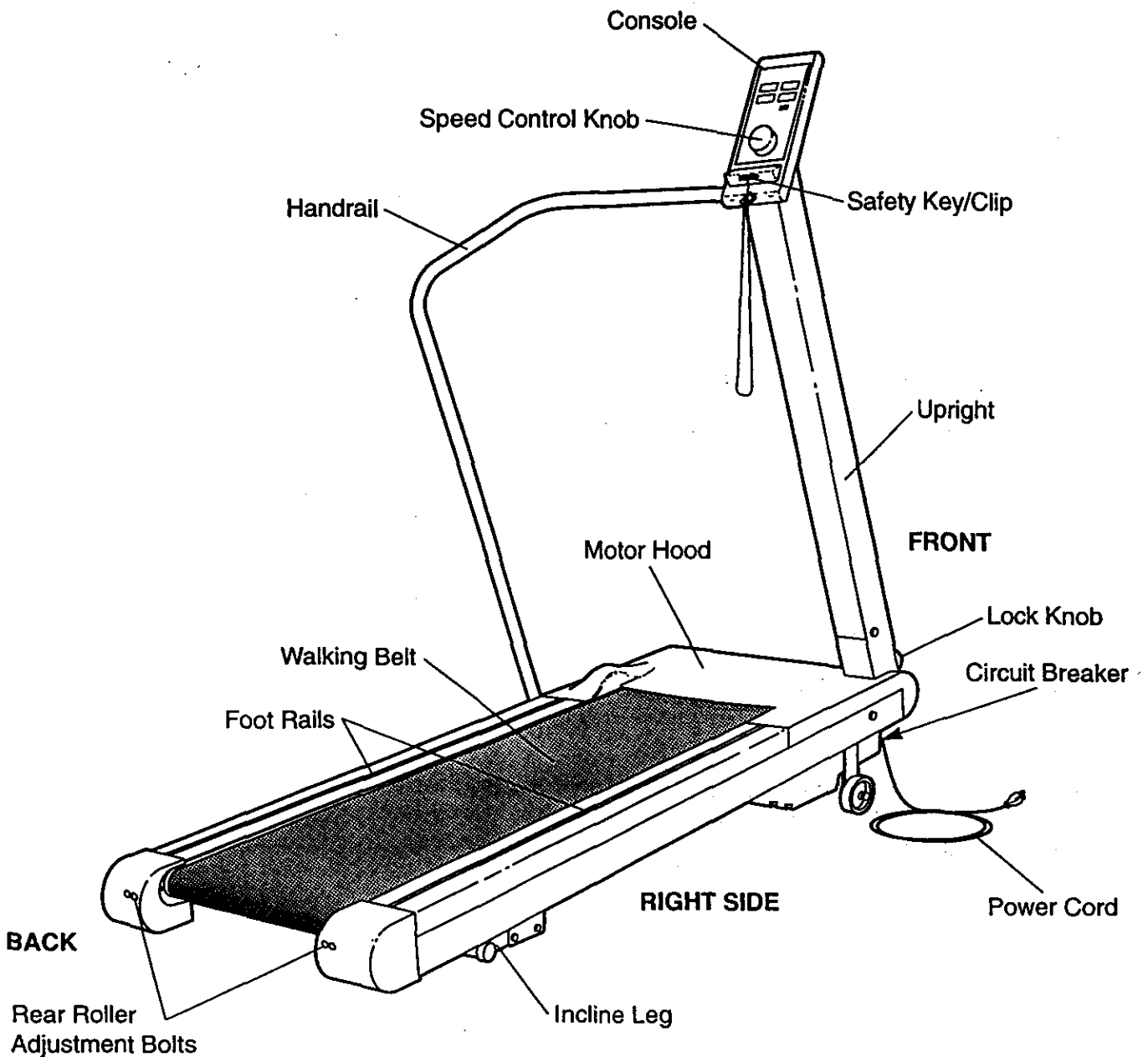

ASSEMBLY

Set the treadmill in a cleared area and remove all packing materials. Do not dispose of the packing materials until assembly is completed. **TOOLS REQUIRED FOR ASSEMBLY: An 8" adjustable wrench**  (not included).

1. Raise the Upright (11) and Handrail (not shown), to a vertical position. Insert the Lock Knob (13), with the Lock Knob Washer (14), into the Upright and turn the Knob clockwise until it is almost tight. Leave a little play in the Upright for the following steps.

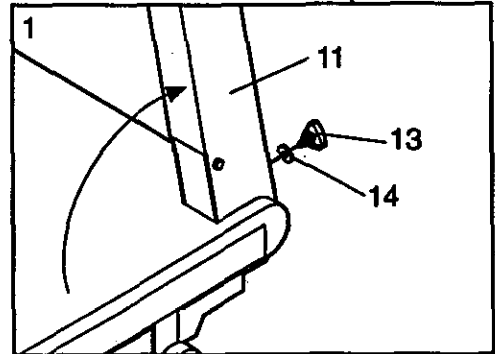

2. Align the hole in the lower end of the Handrail (1) with the hole in the side of the Frame (37). Insert a Handrail Bolt (74), with a Handrail Washer (9), into the Handrail and tighten the Bolt into the Frame.

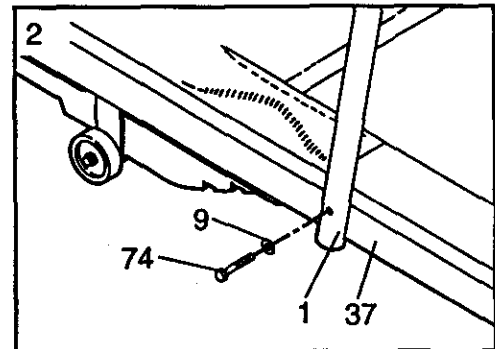

3. Tighten the Acorn Nut (10) on the side of the Upright (11).
Tighten the Lock Knob (13) (see step 1).

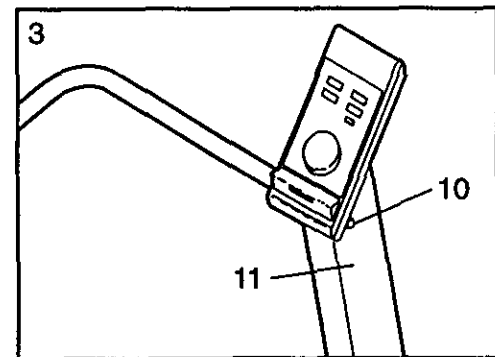

4. Remove the paper backing from the Wrench Clip (68). Press the Wrench Clip onto the Right Endcap (64) in the indicated location. Press the Allen Wrench (66) into the Wrench Clip.

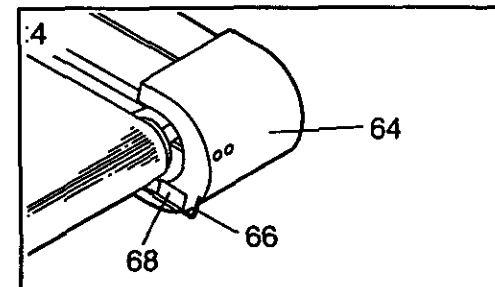

Make sure that all parts are tightened before using the treadmill. **Note: To protect the floor, a covering should be placed under the treadmill.**

OPERATION AND ADJUSTMENT

PLUGGING IN THE POWER CORD

This product must be grounded. If it should malfunction or break down, grounding provides a path of least resistance for electric current to reduce the risk of electric shock. This product is equipped with a cord having an equipment-grounding conductor and a grounding plug. **Plug the power cord into an appropriate outlet that is properly installed and grounded in accordance with all local codes and ordinances.**

⚠ DANGER: Improper connection of the equipment-grounding conductor can result in a risk of electric shock. Check with a qualified electrician or serviceman if you are in doubt as to whether the product is properly grounded. Do not modify the plug provided with the product—if it will not fit the outlet, have a proper outlet installed by a qualified electrician.

This product is for use on a nominal 120-volt circuit, and has a grounding plug that looks like the plug illustrated in Drawing 1. A temporary adapter that looks like the adapter illustrated in Drawing 2 may be used to connect this plug to a 2-pole receptacle as shown in Drawing 2 if a properly grounded outlet is not available. The temporary adapter should be used only until a properly grounded outlet (Drawing 1) can be installed by a qualified electrician. The green colored rigid ear, lug, or the like extending from the adapter **must be connected to a permanent ground such as a properly grounded outlet box cover.** Whenever the adapter is used it **must be held in place by a metal screw.**

Some 2-pole receptacle outlet box covers are not grounded. Contact a qualified electrician to determine if the outlet box cover is grounded before using an adapter.

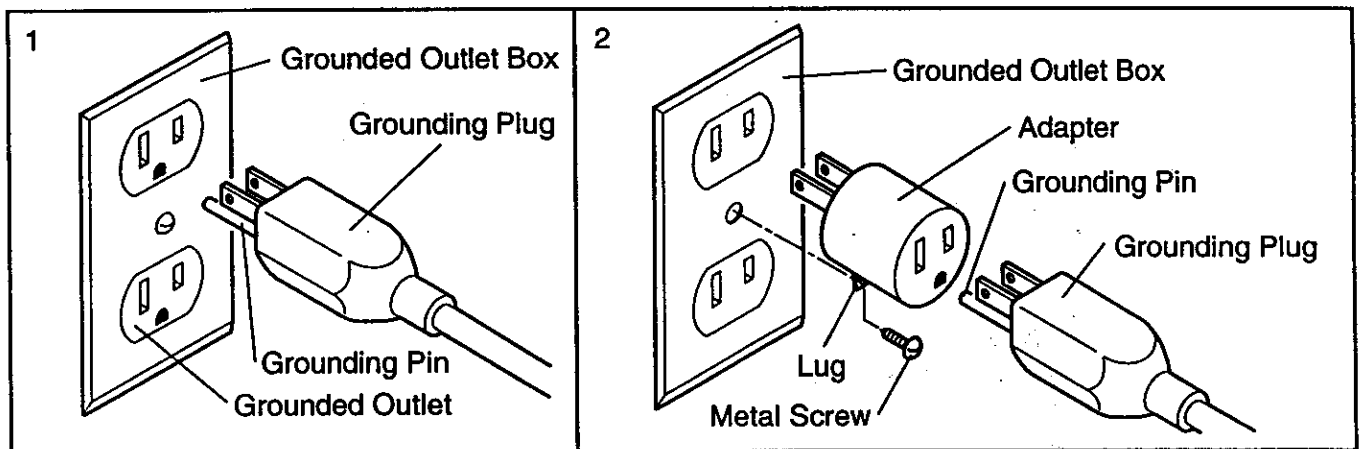

APPLYING SILICONE LUBRICANT

To reduce the friction of the walking belt and minimize wear, a non-oil-, non-petroleum-base silicone lubricant must be applied to the walking platform before the treadmill is used. Failure to apply lubricant will reduce treadmill performance. **WITH THE POWER CORD UNPLUGGED**, lift each side of the walking belt and spray lubricant generously onto the indicated area. Reapply lubricant after every ten hours of use, or whenever performance decreases. Lubricant is available at most hardware and automotive stores. Uni•Sport™ silicone spray is recommended.

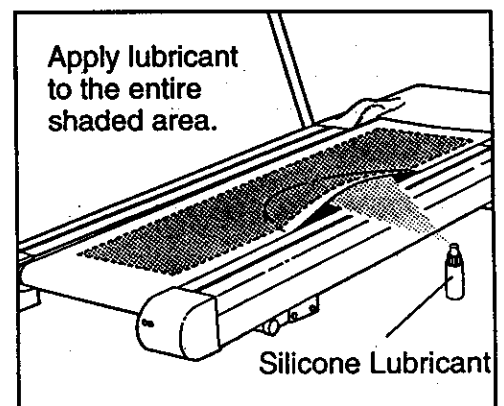

INSTALLING BATTERIES

The motivational fitness monitor requires two "AA" batteries (not included); alkaline batteries are recommended. Slide the battery cover open. Remove the battery clip from the console. Find the markings inside the battery clip showing which direction the batteries should be turned. Press the batteries into the battery clip. Replace the battery clip in the console and close the battery cover. **Note: If there is a sheet of protective plastic on the face of the console, peel it off before operating the console.**

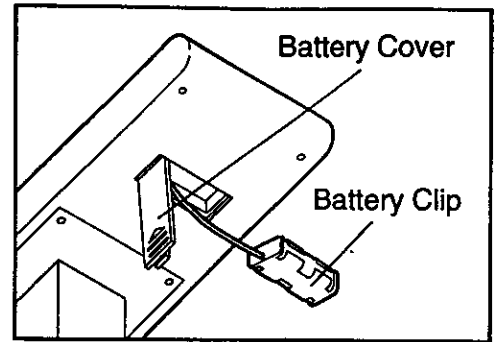

TURNING THE POWER ON

Step onto the foot rails of the treadmill. Locate the clip attached by a cord to the safety key, and slide the clip onto the waistband of your clothing.

▲ CAUTION: Do not stand on the walking belt while turning the power on. Always wear the clip while operating the treadmill; if you fall, the safety key will be pulled from the power switch, instantly turning the power off.

Insert the safety key into the power switch. The power indicator will light. The four displays of the motivational fitness monitor will not appear until the ON/RESET button is pressed, or the walking belt begins to move (see CONTROLLING THE SPEED below). **Note:** If batteries were just installed, the four displays will already appear.

CONTROLLING THE SPEED

To start the walking belt, first turn the speed control knob to "RESET." Then, turn the knob slowly clockwise until the walking belt begins to move at slow speed.

▲ CAUTION: After the knob is turned, there will be a pause before the walking belt begins to move. Adjust the speed slowly until you are familiar with the operation of the treadmill.

Carefully step onto the walking belt and begin exercising. Change the speed of the walking belt as desired by turning the speed control knob. To stop the walking belt, turn the knob to "RESET."

MOTIVATIONAL FITNESS MONITOR

The four displays of the motivational fitness monitor provide continuous exercise feedback. The displays can be reset by pressing the ON/RESET button. The four displays are described below:

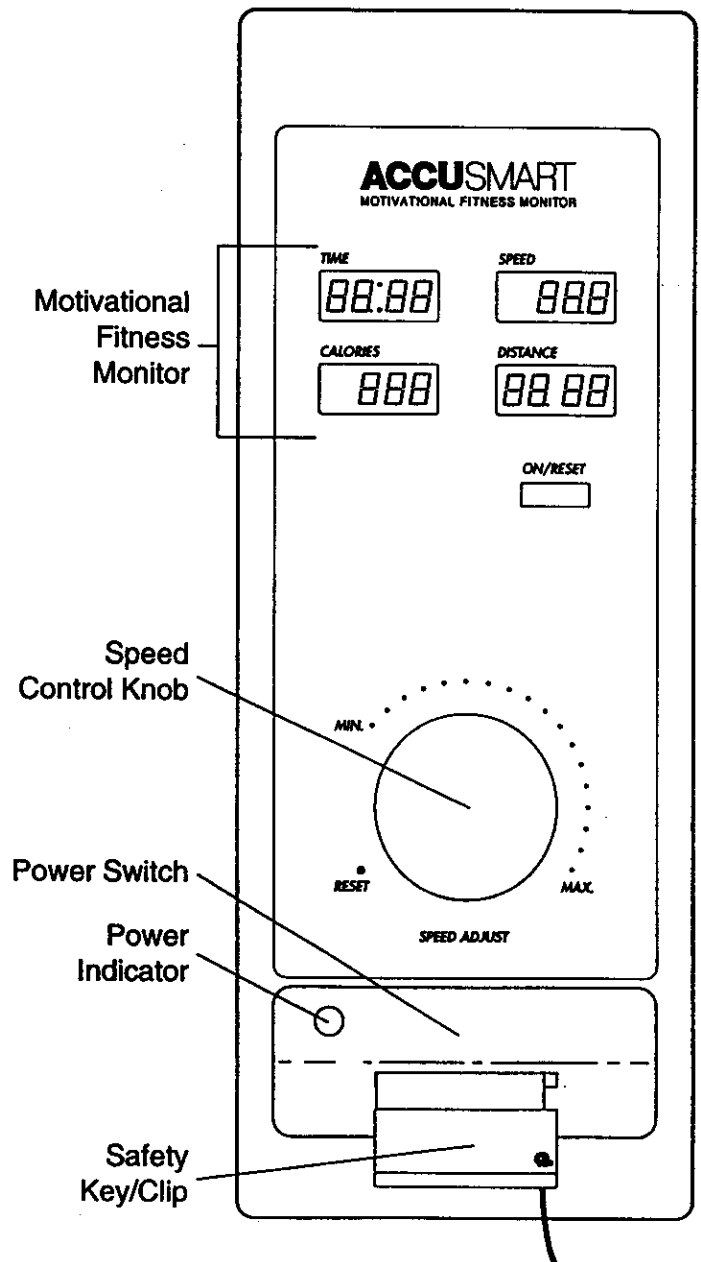

TIME—This display shows the elapsed time. Note: When the walking belt is stopped, the TIME display will go into a pause mode after a few seconds.

CALORIE—This display shows the approximate number of nutritional Calories that you have burned.

SPEED—This display shows the current speed of the walking belt.

DISTANCE—This display shows the total distance that you have walked or run.

Note: If the walking belt is stopped and remains stationary for about five minutes, the four displays of the motivational fitness monitor will be reset and will darken, although the power will remain on. The four displays will appear again when the ON/RESET button is pressed, or the walking belt is restarted.

CHANGING THE INCLINE

To vary the intensity of your exercise, the treadmill can be adjusted to three different incline settings. Before adjusting the incline setting, turn off the power and unplug the power cord. Stand on the floor at the back of the treadmill and grip the endcaps. Lift the back of the treadmill until the incline leg locks into position at the desired incline setting. When the treadmill is lifted above the highest incline setting, the incline will reset and the treadmill can be lowered to the lowest incline setting.

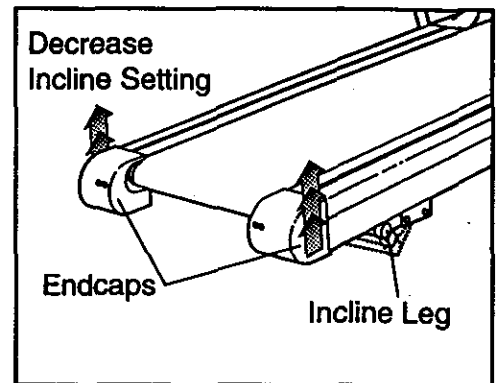

▲ CAUTION: Push slightly on the back of the treadmill to make sure that the incline leg is locked into one of the three incline settings before exercising on the treadmill.

TURNING OFF THE POWER

To turn off the power, remove the safety key from the console. The power indicator will darken. Store the safety key in a secure location.

TROUBLE-SHOOTING AND STORAGE

Most treadmill problems can be solved by following the simple steps below. Find the symptom that applies to your treadmill and follow the steps listed. If further assistance is needed, please call our Customer Service Department toll-free at 1-800-999-3756, Monday through Friday, 6 a.m. until 6 p.m. Mountain Time (excluding holidays).

1. SYMPTOM: THE POWER DOES NOT TURN ON

- a. Make sure that the power cord is plugged into a properly grounded outlet. (See OPERATION AND ADJUSTMENT on page 7.) If an extension cord is needed, use only a 14-gauge general-purpose cord of five feet or less in length.
- b. After the power cord has been plugged in, make sure that the safety key is fully inserted into the console. Various indicators on the console should light. (See OPERATION AND ADJUSTMENT on page 7.)
- c. Check the circuit breaker located on the treadmill frame near the power cord. If the switch protrudes as shown, the circuit breaker has tripped. To reset the circuit breaker, wait for five minutes and then press the switch back in.

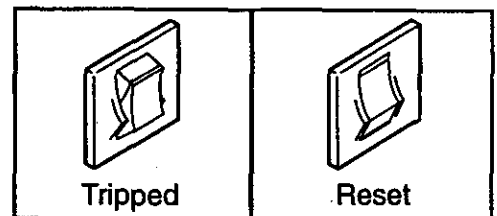

2. SYMPTOM: THE POWER TURNS OFF DURING USE

- a. Check the circuit breaker located on the treadmill frame near the power cord. If the circuit breaker has tripped, the switch will protrude. (See the drawing above.) To reset the circuit breaker, wait for five minutes and then press the switch back in.
- b. Make sure that the power cord is plugged in.
- c. Remove the safety key from the console. Reinsert the safety key fully into the console. Various indicators on the console should light.

3. SYMPTOM: THE WALKING BELT SLOWS WHEN WALKED ON

- a. Apply silicone lubricant to the walking platform before use. Reapply lubricant after every 10 hours of use, and whenever a decrease in performance is noticed. (Uni•Sport silicone spray is recommended.) **CAUTION: UNPLUG THE POWER CORD WHEN APPLYING LUBRICANT.** (See OPERATION AND ADJUSTMENT on page 7 application instructions.)
- b. If an extension cord is needed, use only a 14-gauge general-purpose cord of five feet or less in length.
- c. If the walking belt is overtightened, treadmill performance may decrease and the walking belt may be permanently damaged. Remove the safety key and **UNPLUG THE POWER CORD.** Using the allen wrench, turn both rear roller adjustment bolts counterclockwise, 1/4 of a turn. When the walking belt is properly tightened, you should be able to lift each side of the walking belt 3-4 inches off the walking platform. The center of the walking belt should be just above the walking platform. Be careful to keep the walking belt centered. Plug in the power cord, insert the safety key and run the treadmill for a few minutes. Repeat until the walking belt is properly tightened.

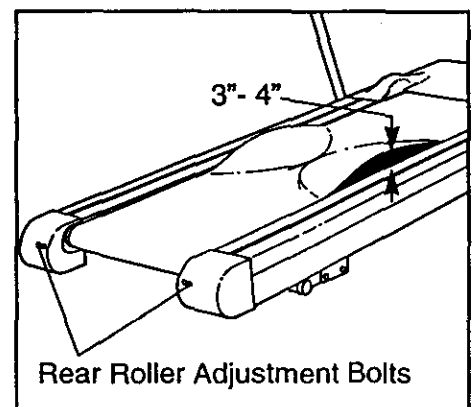

4. SYMPTOM: THE WALKING BELT IS OFF-CENTER OR SLIPS WHEN WALKED ON

a. If the walking belt has shifted to the left, first remove the safety key and **UNPLUG THE POWER CORD**. Using the allen wrench, turn the left rear roller adjustment bolt clockwise, and the right bolt counterclockwise, 1/4 of a turn each. Be careful not to overtighten the walking belt. Plug in the power cord, insert the safety key and run the treadmill for a few minutes. Repeat until the walking belt is centered.

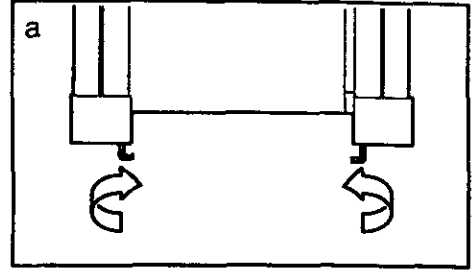

b. If the walking belt has shifted to the right, first remove the safety key and **UNPLUG THE POWER CORD**. Using the allen wrench, turn the left rear roller adjustment bolt counterclockwise, and the right bolt clockwise, 1/4 of a turn each. Be careful not to overtighten the walking belt. Plug in the power cord, insert the safety key and run the treadmill for a few minutes. Repeat until the walking belt is centered.

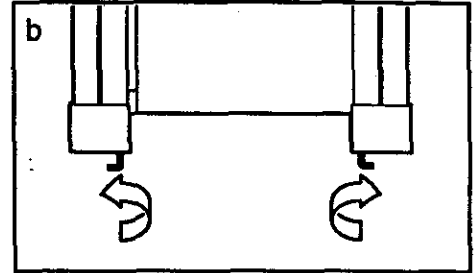

c. If the walking belt slips when walked on, first remove the safety key and **UNPLUG THE POWER CORD**. Using the allen wrench, turn both rear roller adjustment bolts clockwise, 1/4 of a turn. When the walking belt is correctly tightened, you should be able to lift each side of the walking belt 3-4 inches off the walking platform. The center of the walking belt should be just above the walking platform. Be careful to keep the walking belt centered. Plug in the power cord, insert the safety key and run the treadmill for a few minutes. Repeat until the walking belt is properly tightened.

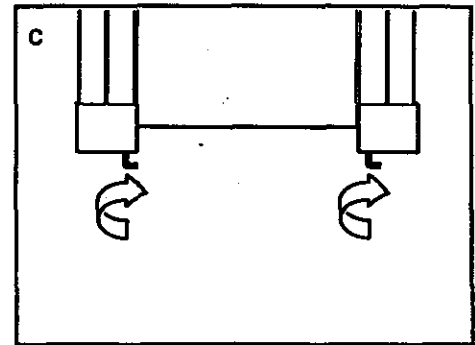

5. SYMPTOM: THE MOTIVATIONAL FITNESS MONITOR DOES NOT FUNCTION PROPERLY

a. Check the batteries in the console. (See **INSTALLING BATTERIES** on page 8.) Most problems are the result of drained batteries.

STORAGE

Unplug the power cord when the treadmill is not in use. Remove the bolt and washer from the lower end of the handrail. Loosen the nut at the upper end of the handrail. Loosen the lock knob at the front of the upright. Carefully lay the upright on the treadmill. Keep the hardware in a secure location. It is recommended that the treadmill be covered during extended periods of storage.

CONDITIONING GUIDELINES

The following guidelines will help you to plan your exercise program. Remember that proper nutrition and adequate rest are essential for successful results.

⚠ WARNING: Before beginning this or any exercise program, consult your physician. This is especially important for individuals over the age of 35 or individuals with pre-existing health problems.

EXERCISE INTENSITY

To maximize the benefits of exercising, it is important to exercise with the proper intensity. The proper intensity can be found by using your heart rate as a guide. For effective aerobic exercise, your heart rate should be maintained at a level between 70% and 85% of your maximum heart rate as you exercise. This is known as your training zone. You can find your training zone in the table below. Training zones are listed for both unconditioned and conditioned persons according to age.

AGE	UNCONDITIONED TRAINING ZONE (BEATS/MIN)	CONDITIONED TRAINING ZONE (BEATS/MIN)	AGE	UNCONDITIONED TRAINING ZONE (BEATS/MIN)	CONDITIONED TRAINING ZONE (BEATS/MIN)
20	138-167	133-162	55	127-155	122-149
25	136-166	132-160	60	126-153	121-147
30	135-164	130-158	65	125-151	119-145
35	134-162	129-156	70	123-150	118-144
40	132-161	127-155	75	122-147	117-142
45	131-159	125-153	80	120-146	115-140
50	129-156	124-150	85	118-144	114-139

During the first few months of your exercise program, keep your heart rate near the low end of your training zone as you exercise. After a few months, your heart rate can be increased gradually until it is near the middle of your training zone as you exercise. To measure your heart rate, stop exercising and place two fingers on your wrist. Take a six-second heartbeat count, and multiply the result by 10 to find your heart rate. For example, if your six-second heartbeat count is 14, your heart rate is 140 beats per minute. (A six-second count is used because your heart rate will drop rapidly when you stop exercising.) Adjust the intensity of your exercise until your heart rate is at the proper level.

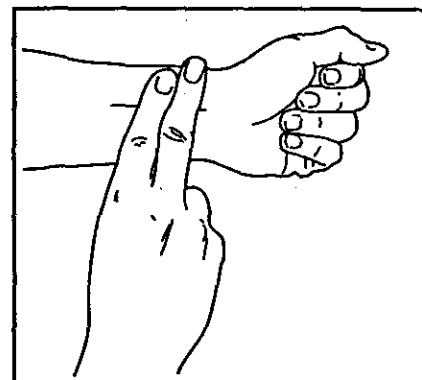

WORKOUT GUIDELINES

Each workout should consist of three basic parts: a warm-up, 20 to 30 minutes of training zone exercise, and a cool-down. Warming up prepares the body for exercise by increasing circulation, delivering more oxygen to the muscles and raising the body temperature. Begin each workout with 5 to 10 minutes of stretching and light exercise to warm up. Then, increase the intensity of your exercise to raise your heart rate to your training zone for 20 to 30 minutes. Breathe regularly and deeply as you exercise—never hold your breath. Finish each workout with 5 to 10 minutes of stretching to cool down. This will increase the flexibility of the muscles, and reduce soreness and other post-exercise problems. To maintain or improve your condition, complete three workouts each week, with at least one day of rest between workouts. After a few months of regular exercise, you may complete up to five workouts each week, if desired. The key to success is CONSISTENCY.

SUGGESTED STRETCHES

The following stretches can provide a good warm-up or cool-down. Correct form for each stretch is shown in the drawings below. Move slowly as you stretch—never bounce.

TOE TOUCH STRETCH

Stand with your knees bent slightly and slowly bend forward from your hips. Allow your back and shoulders to relax as you reach down toward your toes as far as possible. Hold for 15 counts, then relax. Repeat 3 times.

Stretches: Hamstrings, back of knees and back.

HAMSTRING STRETCH

Sit with one leg extended. Bring the sole of the opposite foot toward you and rest it against the inner thigh of your extended leg. Reach toward your toes as far as possible. Hold for 15 counts, then relax. Repeat 3 times for both legs.

Stretches: Hamstrings, lower back and groin.

CALF/ACHILLES STRETCH

With one leg in front of the other, reach forward and place your hands against a wall. Keep your back leg straight and your back foot flat on the floor. Bend your front leg, lean forward and move your hips toward the wall. Hold for 15 counts, then relax. Repeat 3 times for both legs. To cause further stretching of the achilles tendons, bend your back leg as well.

Stretches: Calves, achilles tendons and ankles.

QUADRICEPS STRETCH

With one hand against a wall for balance, reach back and grasp one foot with your other hand. Bring your heel as close to your buttocks as possible. Hold for 15 counts, then relax. Repeat 3 times for both legs.

Stretches: Quadriceps and hip muscles.

INNER THIGH STRETCH

Sit with the soles of your feet together and your knees outward. Pull your feet toward your groin area as far as possible. Hold for 15 counts, then relax. Repeat 3 times.

Stretches: Quadriceps and hip muscles.

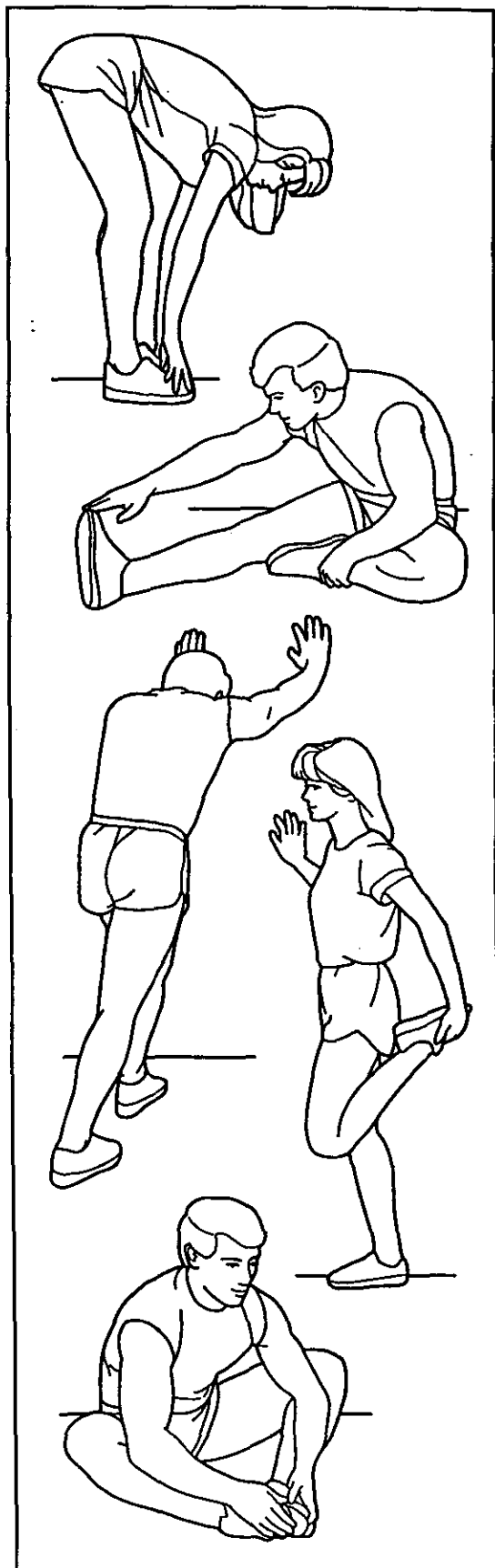

PART LIST—Model No. 831.297420

R894A

Key No.	Part No.	Qty.	Description	Key No.	Part No.	Qty.	Description
1	114218	1	Handrail	44	100541	2	Motor Swivel Bolt
2	114575	1	Safety Key/Clip	45	031238	1	Choke
3	110000	1	Speed Control Knob	46	120647	1	Motor
4	120650	1	Console	47	105477	2	Motor Nut
5	108404	9	Screw	48	108276	1	Pulley/Flywheel/Fan
6	113203	1	6" Cable Loom	49	102959	2	Small Bolt
7	116131	1	Power Switch Wire	50	013547	4	Incline Leg Bolt
8	012149	1	Pivot Nut	51	120655	2	Incline Leg Spring
9	014132	5	Handrail Washer/Pivot Washer	52	012152	4	Small Nut
10	114268	1	Acorn Nut	53	014087	4	Incline Leg Washer
11	119350	1	Upright	54	120663	2	Incline Leg Latch
12	120003	1	Pivot Bolt	55	013300	5	Hood Bracket Screw
13	017088	1	Upright Knob	56	120656	4	Incline Leg Spacer
14	014156	1	Upright Washer	57	012108	4	Incline Leg Nut
15	012056	2	Lock Nut	58	120746	2	Incline Leg Cap
16	031229	1	Power Cord	59	120657	1	Incline Leg
17	113204	1	12" Cable Loom	60	119503	1	Controller/Choke Plate
18	019084	1	Grommet	61	114261	1	Ground Wire
19	111869	1	Upright Cage Nut	62	016057	4	8" Cable Tie
20	109382	1	Circuit Breaker	63	016029	2	4" Cable Tie
21	113106	5	Hood Anchor	64	119348	1	Right Endcap
22	013088	10	Safety Cover Screw	65	013206	2	Rear Roller Adj. Bolts
23	112609	1	Front Roller Adj. Bolt	66	045010	1	Allen Wrench
24	014127	2	Adjustment Washer	67	119347	1	Left Endcap
25	052014	2	Front Wheel	68	016028	2	Wrench Clip
26	117806	2	Front Wheel Bolt	69	113050	2	Rear Roller Spacer
27	012082	1	Tension Nut	70	109788	1	Rear Roller
28	118153	1	Reed Switch/Sensor Wire	71	010206	2	Roller Guard
29	118332	1	Extension Wire	72	013162	2	Roller Guard Screw
30	109265	2	Belt Guide	73	100691	6	Platform Screw
31	013423	8	Guide Screw/Leg Screw	74	112001	1	Handrail Bolt
32	120649	2	Foot Rail	75	120645	1	Motor Hood w/Decal
33	117841	1	Safety Cover	76	111430	1	Handrail Cage Nut
34	117273	1	Front Roller/Pulley	77	114355	1	Front Roller Spacer
35	120526	1	Walking Platform	78	115809	1	Belt
36	120525	1	Walking Belt	79	016055	1	Wire Clip
37	NSP	1	Frame	80	116890	1	Tabbed Washer
38	103855	1	J-Bolt	81	014041	2	Tension Washer
39	121637	1	Motor Swivel	82	104514	1	Tension Spring
40	100994	2	Motor Bolt	83	120527	2	Platform Shim
41	108080	8	Small Screw	#	118204	1	8" Blue Jumper Wire
42	109786	1	Controller	#	119407	1	Owner's Manual
43	014073	2	Motor Swivel Washer				

Note: "#" indicates a non-illustrated part. Specifications are subject to change without notice. See the back cover for information about ordering replacement parts.

EXPLODED DRAWING—Model No. 831.297420

R894A

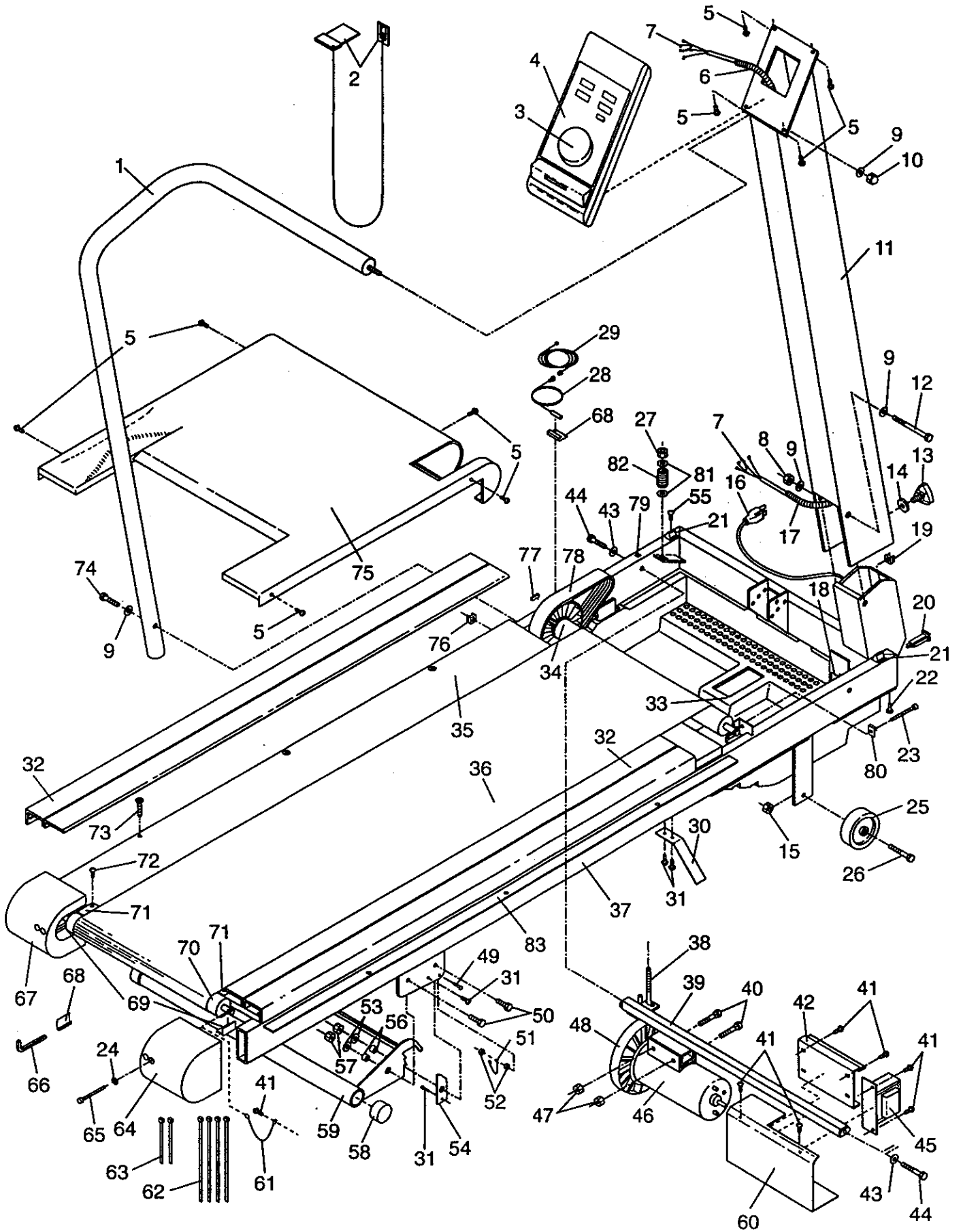

ORDERING REPLACEMENT PARTS

Each TREADMILL has its own MODEL NUMBER. Always mention this MODEL NUMBER when requesting service or repair parts for your TREADMILL.

All parts listed herein can be ordered through SEARS, ROEBUCK AND CO. SERVICE CENTERS and most SEARS RETAIL STORES. If parts you need are not stocked locally, your order will be transmitted to a SEARS PARTS DISTRIBUTION CENTER for handling.

WHEN ORDERING REPAIR PARTS, ALWAYS GIVE THE FOLLOWING INFORMATION:

1. The MODEL NUMBER of the product (831.297420).
2. The NAME of the product (SEARS LIFESTYLER® 10.0 treadmill).
3. The PART NUMBER of the part(s) from page 14 of this owner's manual.
4. The DESCRIPTION of the part(s) from page 14 of this owner's manual.

Your SEARS TREADMILL has added value when you consider that SEARS has service units nationwide, staffed with SEARS trained technicians specifically trained on SEARS products, having the parts, tools and equipment to ensure that we meet our pledge to you: "We service what we sell."

Should you ever need repair service or parts, call toll free:

For repair service: **1-800-4-REPAIR** (1-800-473-7247)

For repair parts: **1-800-FON-PART** (1-800-366-7278)