

PRO-FORM[®] 580_{Si}

SEARS

Model No. 831.297642

Serial No. _____

The serial number can be found in the location shown below. Write the serial number in the space above.

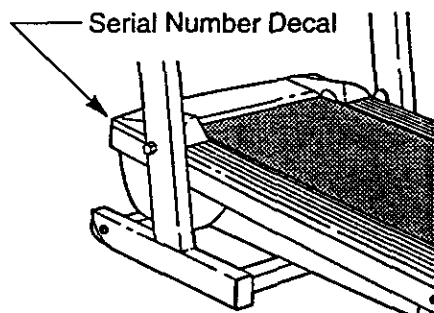

EXERCISE
EQUIPMENT

QUESTIONS

HELPLINE!

1-800-736-6879

▲ CAUTION

Read all precautions and instructions in this manual before using this equipment. Keep this manual for future reference.

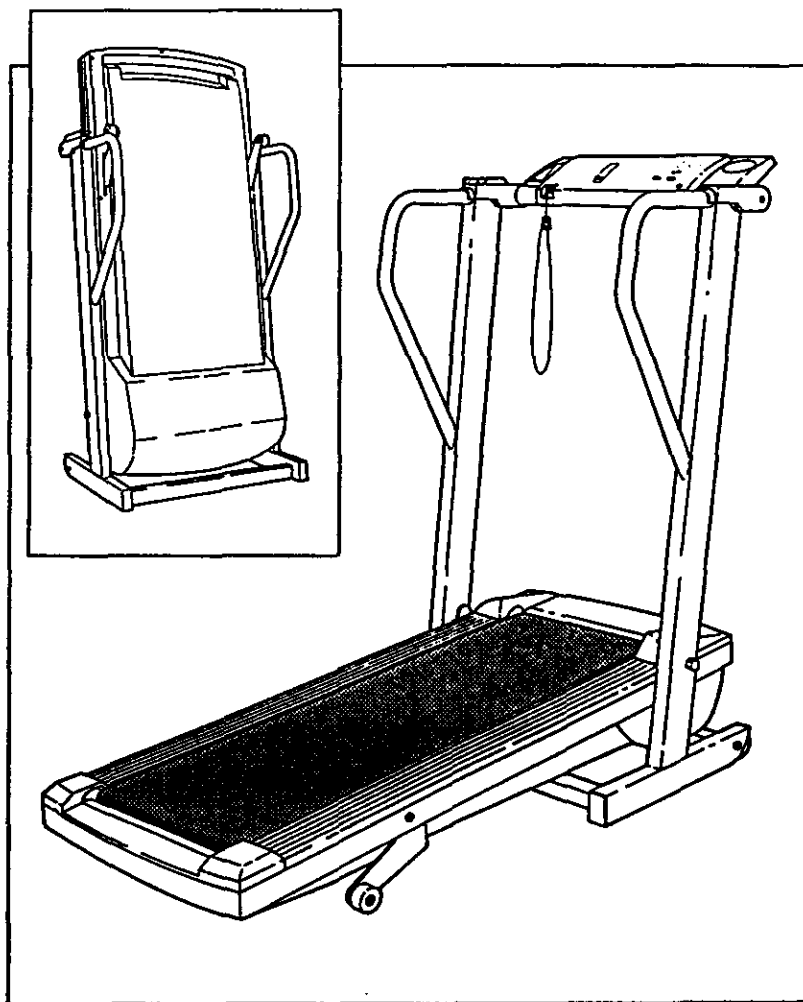

USER'S MANUAL

FULL 90 DAY WARRANTY

For 90 days from the date of purchase, if failure occurs due to defect in material or workmanship in this SEARS TREADMILL EXERCISER, contact the nearest SEARS Service Center throughout the United States and SEARS will repair or replace the TREADMILL EXERCISER, free of charge.

This warranty does not apply when the TREADMILL EXERCISER is used commercially or for rental purposes.

This warranty gives you specific legal rights, and you may also have other rights which vary from state to state.

SEARS, ROEBUCK AND CO., DEPT. 817WA, HOFFMAN ESTATES, IL 60179

PRO-FORM[®] 580_{Si}

TABLE OF CONTENTS

| | |
|--|------------|
| FULL 90 DAY WARRANTY | 2 |
| IMPORTANT PRECAUTIONS | 4 |
| BEFORE YOU BEGIN | 5 |
| ASSEMBLY | 6 |
| OPERATION AND ADJUSTMENT | 7 |
| HOW TO FOLD AND MOVE THE TREADMILL | 10 |
| TROUBLE-SHOOTING AND STORAGE | 12 |
| CONDITIONING GUIDELINES | 14 |
| ORDERING REPLACEMENT PARTS | Back Cover |

Note: An EXPLODED DRAWING and a PART LIST are attached to the center of this manual. Save the EXPLODED DRAWING and PART LIST for future reference.

⚠WARNING: Before beginning this or any exercise program, consult your physician. This is especially important for persons over the age of 35 or persons with pre-existing health problems. Read all instructions before using. SEARS assumes no responsibility for personal injury or property damage sustained by or through the use of this product.

IMPORTANT PRECAUTIONS

▲ WARNING: To reduce the risk of burns, fire, electric shock or injury to persons, read the following important precautions and information before operating the treadmill.

1. It is the responsibility of the owner to ensure that all users of this treadmill are adequately informed of all warnings and precautions.
2. Use the treadmill only as described in this manual.
3. Place the treadmill on a level surface, with at least 8 feet of clearance behind it. To protect the floor or carpet from damage, place a mat under the treadmill.
4. Do not place the treadmill near water, outdoors, or on a surface that blocks any air openings.
5. Do not operate the treadmill where aerosol products are used or where oxygen is being administered.
6. Keep small children and pets away from the treadmill at all times.
7. The treadmill should be used only by persons weighing 250 pounds or less.
8. Never allow more than one person on the treadmill at a time.
9. When connecting the power cord (see HOW TO PLUG IN THE POWER CORD on page 7), plug the power cord into a surge protector (not included) and plug the surge protector into a grounded circuit capable of carrying 15 or more amps. No other appliance should be on the same circuit.
10. Use only a UL-listed surge protector, rated at 15 amps, with a 14-gauge cord of five feet or less in length. Do not use an extension cord.
11. Keep the power cord and the surge protector away from heated surfaces.
12. Never move the walking belt while the power is turned off. Do not operate the treadmill if the power cord or plug is damaged, or if the treadmill is not working properly. (See BEFORE YOU BEGIN on page 5 if the treadmill is not working properly.)
13. Wear appropriate exercise attire when using the treadmill. Do not wear loose clothing that could become caught in the treadmill. Athletic support clothes are recommended for both men and women. *Always wear athletic shoes. Never use the treadmill with bare feet, wearing only stockings, or in sandals.*
14. Never start the treadmill while you are standing on the walking belt. Always hold the handrails while using the treadmill.
15. The treadmill is capable of high speeds. Adjust the speed in small increments to avoid sudden jumps in speed.
16. To reduce the possibility of the treadmill overheating, do not operate the treadmill continuously for longer than 1 hour.
17. The pulse sensor is not a medical device. Various factors, including the user's movement, may affect the accuracy of heart rate readings. The pulse sensor is intended only as an exercise aid in determining heart rate trends in general.
18. Never leave the treadmill unattended while it is running. Always remove the key and move the on/off switch to the "off" position when the treadmill is not in use. (See the drawing on page 5 for the location of the on/off switch.)
19. You must be able to safely lift 45 pounds (20 kg) to raise, lower, or move the treadmill.
20. When storing the treadmill, make sure that the storage latch is fully closed.
21. Never insert any object into any opening.
22. Always unplug the power cord before performing the maintenance and adjustment procedures described in this manual. Never remove the motor hood unless instructed to do so by an authorized service representative. Servicing other than the procedures in this manual should be performed by an authorized service representative only.

SAVE THESE INSTRUCTIONS

BEFORE YOU BEGIN

Thank you for selecting the unique PROFORM® 580si treadmill. The 580si treadmill blends advanced technology with innovative styling to let you enjoy an excellent form of cardiovascular exercise in the convenience and privacy of your home. The 580si offers an impressive array of features to make your workouts more enjoyable and effective. And when you're not exercising, the 580si can be folded up, requiring less than half the floor space of other treadmills.

For your benefit, read this manual carefully before using the treadmill. If you have additional questions,

please call our toll-free HELPLINE at 1-800-736-6879, Monday through Saturday, 7 a.m. until 7 p.m. Central Time (excluding holidays). To help us assist you, please note the product model number and serial number before calling. The model number of the treadmill is 831.297642. The serial number can be found on a decal attached to the treadmill (see the front cover of this manual for the location).

Before reading further, please review the drawing below and familiarize yourself with the parts that are labeled.

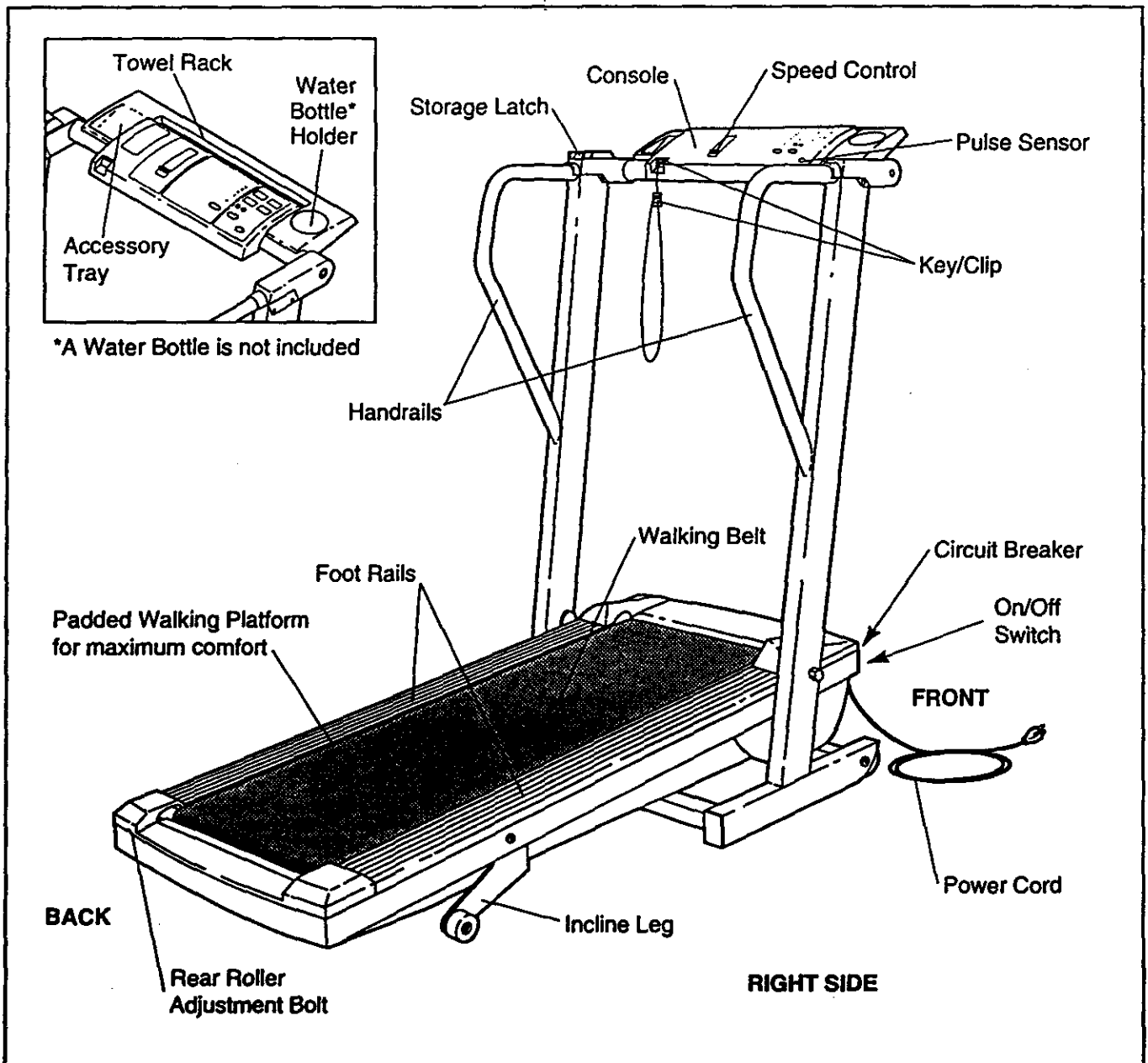

ASSEMBLY

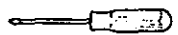
Two people are required for assembly. Set the treadmill in a cleared area and remove all packing materials. Do not dispose of the packing materials until assembly is completed. Assembly requires the included 7/32" allen wrench  and your own phillips screwdriver .

1. Firmly hold one of the Uprights (6, 88) with both hands. Raise the Uprights until the Front Wheels (58) are resting on the floor. The inset drawing shows how the treadmill should appear when this step is completed.

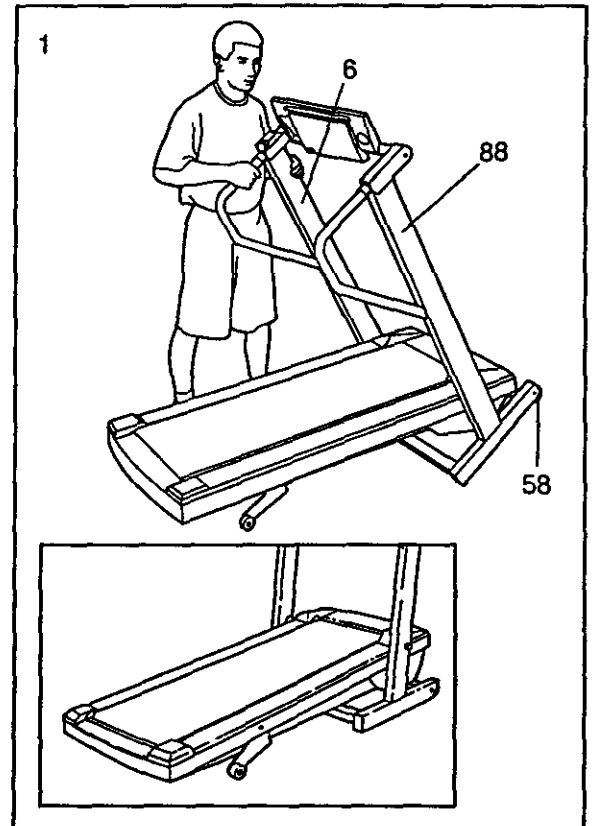

2. Loosen the Crossbar Bolts (1) in the ends of the Console Crossbar (9). Pivot the Console (10) to the angle shown. Look under the Left and Right Console Brackets (3, 36) and find the two small holes in each end of the Console Crossbar (9). Tighten Crossbar Screws (84) into all four holes.

Pivot the Console (10) upward until it stops. Using the 7/32" Allen Wrench (89), tighten the Crossbar Bolts (1).

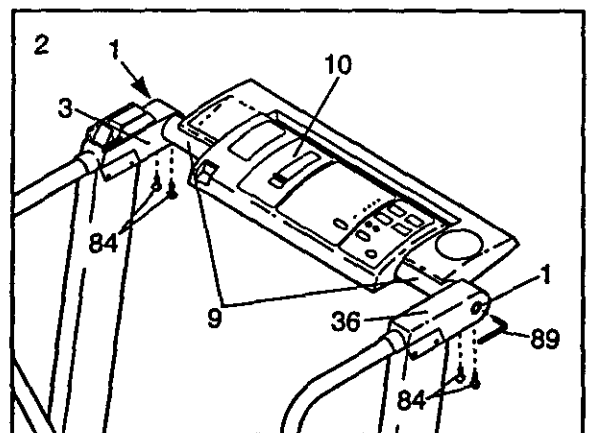

3. Remove the paper backing from the Adhesive Clip (26). Press the Adhesive Clip onto the Frame (49) in the indicated location. Press the 3/16" Allen Wrench (83) into the Adhesive Clip. The use of the 3/16" Allen Wrench is described on pages 12 and 13.

Make sure that all parts are tightened before you use the treadmill. Note: To protect the floor or carpet from damage, place a mat under the treadmill.

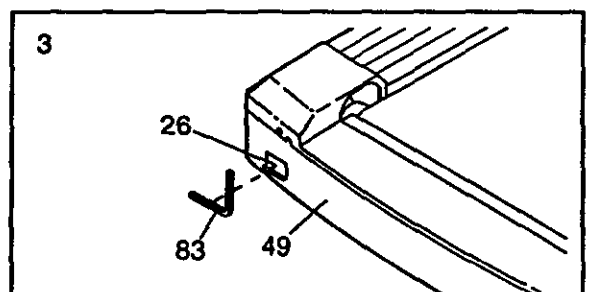

OPERATION AND ADJUSTMENT

THE PERFORMANT LUBE™ WALKING BELT

Your treadmill features a walking belt coated with PERFORMANT LUBE™, a high-performance lubricant. During the first few hours of use, it is normal for a small amount of white powder to appear on the foot rails and the walking platform. The white powder is excess lubricant from the walking belt.

IMPORTANT: Never apply silicone spray or other substances to the walking belt or the walking platform. They will deteriorate the walking belt and cause excessive wear.

HOW TO PLUG IN THE POWER CORD

⚠ DANGER: Improper connection of the equipment-grounding conductor can result in an increased risk of electric shock. Check with a qualified electrician or serviceman if you are in doubt as to whether the product is properly grounded. Do not modify the plug provided with the product—if it will not fit the outlet, have a proper outlet installed by a qualified electrician.

Your treadmill, like any other type of sophisticated electronic equipment, can be seriously damaged by sudden voltage

changes in your home's power. Voltage surges, spikes, and noise interference can result from weather conditions or from other appliances being turned on or off. To decrease the possibility of your treadmill being damaged, always use a surge protector (not included) with your treadmill.

Surge protectors are sold at most hardware stores and department stores. Use only a UL-listed surge protector, rated at 15 amps, with a 14-gauge cord of five feet or less in length.

This product must be grounded. If it should malfunction or break down, grounding provides a path of least resistance for electric current to reduce the risk of electric shock. This product is equipped with a cord having an equipment-grounding conductor and a grounding plug. Plug the power cord into a surge protector, and plug the surge protector into an appropriate outlet that is properly installed and grounded in accordance with all local codes and ordinances.

This product is for use on a nominal 120-volt circuit, and has a grounding plug that looks like the plug illustrated in drawing 1 below. A temporary adapter that looks like the adapter illustrated in drawing 2 may be used to connect the surge protector to a 2-pole receptacle as shown in drawing 2 if a properly grounded outlet is not available.

The temporary adapter should be used only until a properly grounded outlet (drawing 1) can be installed by a qualified electrician.

The green-colored rigid ear, lug, or the like extending from the adapter must be connected to a permanent ground such as a properly grounded outlet box cover. Whenever the adapter is used it must be held in place by a metal screw. Some 2-pole receptacle outlet box covers are not grounded. Contact a qualified electrician to determine if the outlet box cover is grounded before using an adapter.

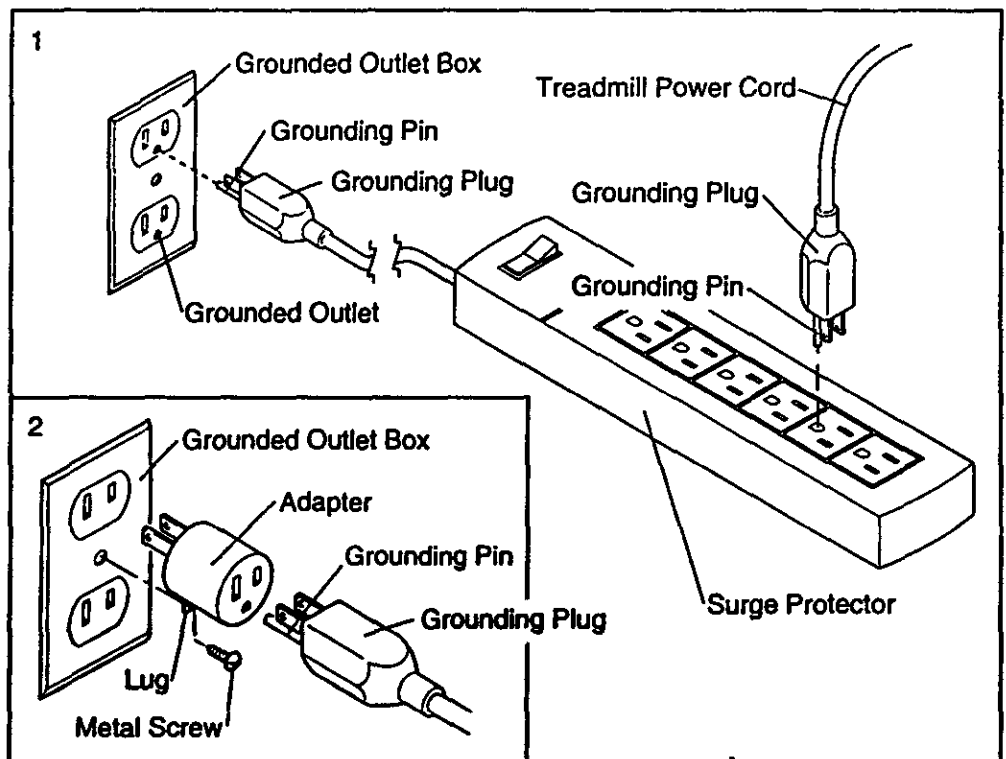
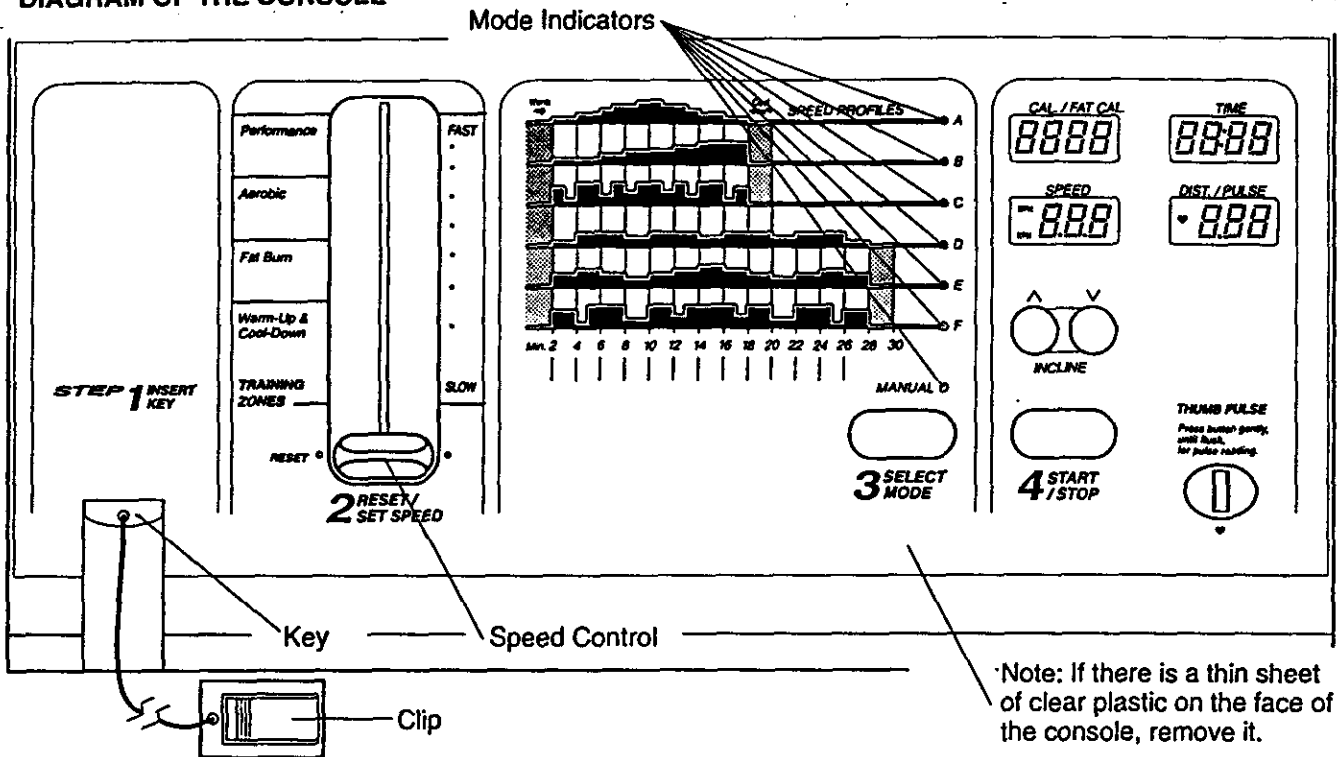

DIAGRAM OF THE CONSOLE



CAUTION: Before operating the console, read the following precautions.

- Do not stand on the walking belt when turning on the power.
- Always wear the clip while operating the treadmill.
- Adjust the speed in small increments.
- To reduce the possibility of electric shock, keep the console dry. Avoid spilling liquids on the console, and use only a sealed water bottle.
- The training zones marked beside the speed control are general guidelines only. See **CONDITIONING GUIDELINES** on page 14.

STEP BY STEP CONSOLE OPERATION

The treadmill console features a manual mode and six preset workout programs. In the manual mode, the speed of the walking belt can be changed with the electronic speed control. When one of the workout programs is selected, the console will automatically control the speed as it guides you through an effective workout.

Before operating the console, make sure that the on/off switch near the power cord is in the "on" position.

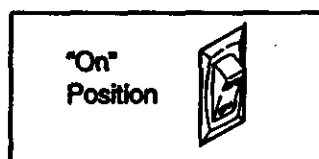

the power cord is properly plugged in. (See **HOW TO PLUG IN THE POWER CORD** on page 7.)

Next, step onto the foot rails of the treadmill. Find the clip attached to the key (see the drawing above), and slide the clip onto the waistband of your clothing. Follow the steps below to operate the console:

1 Insert the key fully into the power switch.

The four displays and the green MANUAL mode indicator will light.

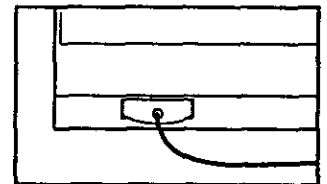

2 Reset the speed control and select a speed setting.

Slide the speed control down to the "RESET" position. **Note:** Each time the walking belt is stopped, the speed control must be moved to the "RESET" position before the walking belt can be restarted.

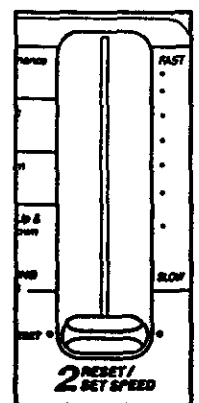

Next, slide the speed control upward to select a speed setting. **Note:** If the key was just inserted, or if the walking belt was stopped with the START/STOP button, the walking belt will not begin to move yet.

8 If the key is in the console, remove it. Make sure that

3 Press the **SELECT MODE** button to select the desired mode.

When the key is inserted, the console will be in the **MANUAL** mode.

If you want to select one of the six preset programs, press the **SELECT MODE** button. The red **PROGRAM A** indicator will light. To select **PROGRAM B, C, D, E, or F**, repeatedly press the **SELECT MODE** button.

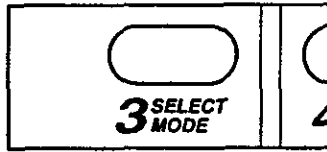

Note: **PROGRAMS A, B, and C** are twenty-minute programs; **PROGRAMS D, E, and F** are thirty-minute programs. The speed profiles in the center of the console show how the speed of the walking belt will change during the programs. During **PROGRAM A**, for example, the speed will gradually increase during the first ten minutes, and then gradually decrease during the last ten minutes. Each program will begin with a two-minute warm-up period, and end with a two-minute cool-down period.

4 Press the **START/STOP** button.

After the **START/STOP** button is pressed, the walking belt will begin to move. Hold the handrails and carefully begin walking on the walking belt.



If the console is in the manual mode, change the speed of the walking belt as desired by sliding the speed control. To stop the walking belt, slide the speed control to the **"RESET"** position. The walking belt can also be stopped by pressing the **START/STOP** button; however, this will reset the displays.

If one of the preset programs is selected, the speed setting you selected will be the minimum speed setting for the program. The speed of the walking belt will then change automatically during the program as shown by the speed profiles in the center of the console. When the program is completed, the walking belt will automatically slow to a stop. Note: If the intensity level of the program is too easy or too difficult, adjust the speed control to select a new minimum speed setting. To stop the program temporarily, slide the speed control to the **"RESET"** position. To restart the program, slide the speed control up to the desired position. To terminate the program before the program is completed, press the **START/STOP** button. If you select a different program while a program is running, the walking belt will slow to a stop.

5 Follow your progress with the monitor displays.

The four monitor displays provide instant feedback:

- **CAL/FAT CAL display**—Displays the approximate numbers of **Calories** and **Fat Calories** you have burned (see **BURNING FAT** on page 14). Every seven seconds, the display will change from one number to the other (an **"F"** will appear when the number of **Fat Calories** is shown). Note: The actual number of **Calories** you have burned may differ slightly from the number shown if the speed or incline is near the lowest or highest setting.



- **TIME display**—When the console is in the manual mode, the elapsed time will be shown. When one of the preset programs is selected, the time remaining in the program will be displayed.



- **SPEED display**—Displays the speed of the walking belt, in **miles per hour (MPH)** or **kilometers per hour (KPH)**.



Note: To change the unit of measurement, hold down the **START/STOP** button while inserting

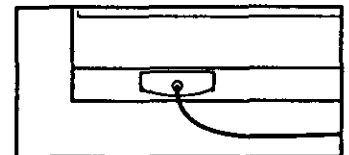

the key into the console. An **"E"** (for English system—miles per hour) or **"M"** (for Metric system—kilometers per hour) will appear in the **DISTANCE/PULSE** display. Press the **SELECT MODE** button to select the desired setting. Remove and then reinsert the **KEY**. An **MPH** or a **KPH** will appear in the **SPEED** display to show which unit of measurement you have selected.

- **DISTANCE/PULSE display**—Displays the distance you have walked or run. If an **MPH** appears in the **SPEED** display, the distance will be displayed in miles. If a **KPH** appears, the distance will be displayed in kilometers. This display also shows your pulse when the pulse sensor is used (see step 6).

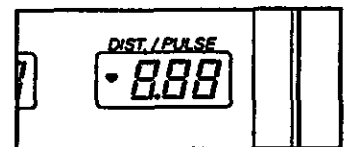

6 Measure your pulse, if desired.

To use the pulse sensor, stand on the foot rails and place your thumb on the pulse sensor as shown.

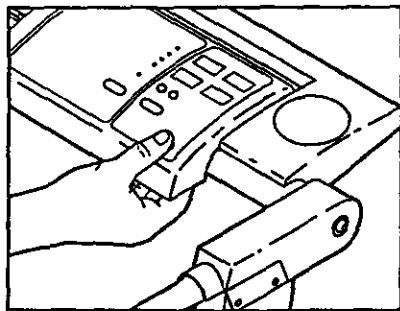

The pulse sensor is pressure-activated. Fully press down the pulse sensor. Do not press too hard, or the circulation in your thumb will be restricted, and your pulse will not be detected. Next, slightly raise your thumb until the heart in the DISTANCE/PULSE display flashes steadily. Hold your thumb at this level. After 5 to 10 seconds, your pulse will be displayed. If the displayed pulse appears to be too high or too low, or if your pulse is not displayed, lift your thumb off the sensor and allow the display to reset. Press down again on the sensor as described above. Make sure that your thumb is positioned as shown, and that you are applying the proper amount of pressure to the pulse sensor.

Try the sensor several times until you become familiar with it. Remember to stand still while measuring your pulse.

7 Change the incline of the treadmill, if desired.

To change the incline, hold down one of the incline buttons until the desired incline is reached.

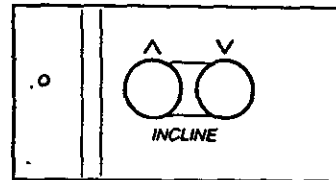

8 When you are finished, remove the key.

Step onto the foot rails and remove the key from the console. Store the key in a secure place. In addition, move the on/off switch to the "off" position. (See the drawing near the bottom of page 8.)

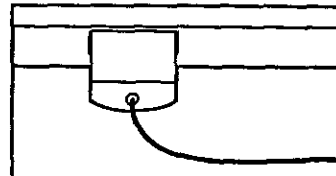

THE INFORMATION MODE

The console features an information mode that keeps track of the total time and distance accumulated on the treadmill. To access this mode, hold down the START/STOP button while inserting the key into the console. The TIME display will show the total time. The SPEED display will show the total distance (if the total distance exceeds 999, the thousands and ten thousands digits will be shown in the CAL/FAT CAL display). The DISTANCE/PULSE display will show an "E" or an "M," indicating miles or kilometers (see SPEED DISPLAY on page 9). To exit the information mode, remove the key from the console.

HOW TO FOLD AND MOVE THE TREADMILL

HOW TO FOLD THE TREADMILL FOR STORAGE

Before folding the treadmill for storage, unplug the power cord. You must be able to safely lift 45 pounds (20 kg) in order to raise, lower, or move the treadmill.

1. Hold the treadmill firmly with your hands in the locations shown at the right. To decrease the possibility of injury, bend your legs and keep your back straight. Raise the treadmill to a vertical position. Make sure to lift with your legs rather than your back.

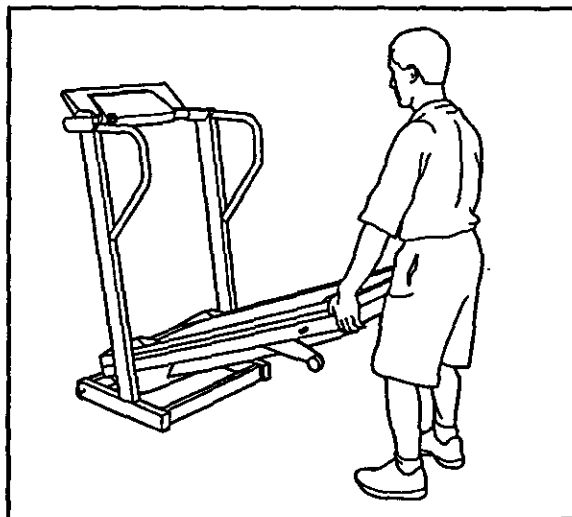

2. Pivot the treadmill until the locking pin snaps into the storage latch. Using your left hand, lift the storage latch. Raise the treadmill until the locking pin snaps into the storage latch. **Make sure that the locking pin is inside the storage latch, and that the storage latch is fully closed.**

To protect the floor or carpet from damage, place a mat under the treadmill. Keep the treadmill out of direct sunlight. Do not leave the treadmill in the storage position in temperatures above 85° Fahrenheit.

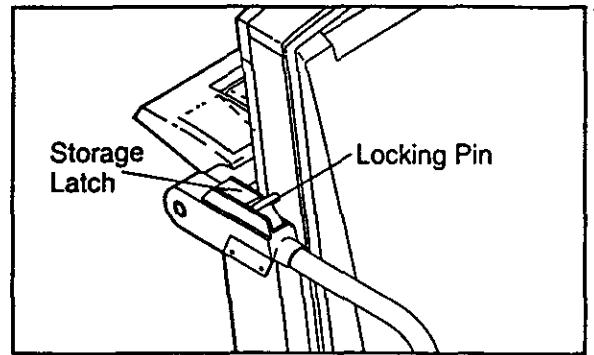

HOW TO MOVE THE TREADMILL

Before moving the treadmill, convert the treadmill to the storage position as described on page 10.

1. Hold one console bracket with each hand. Place one foot on the base crossbar as shown.
2. Tilt the treadmill back until it rolls freely on the front wheels. Carefully move the treadmill to the desired location. **To reduce the risk of injury, use extreme caution while moving the treadmill. Do not attempt to move the treadmill over an uneven surface.**
3. Place one foot on the base crossbar, and carefully lower the treadmill until it is resting in the storage position.

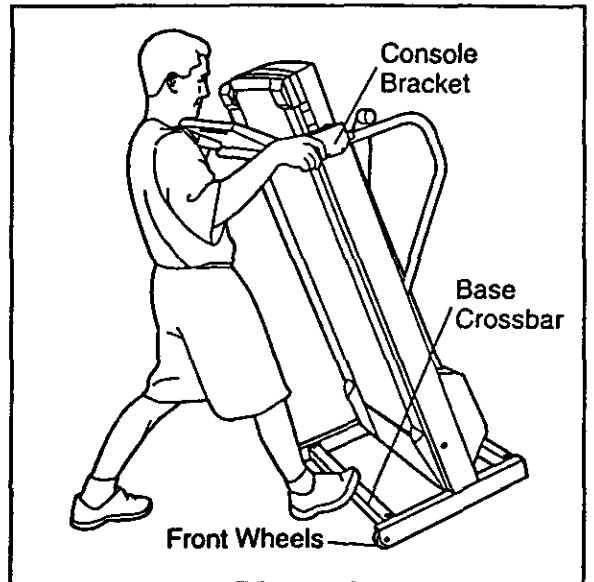

HOW TO FOLD THE TREADMILL DOWN FOR USE

1. Hold the upper end of the treadmill with your right hand as shown. Using your left hand, lift the storage latch. Pivot the treadmill slightly until the locking pin is out of the storage latch. **Make sure that the storage latch is fully closed.**
2. Hold the treadmill firmly with both hands, and lower the treadmill to the floor. **To decrease the possibility of injury, bend your legs and keep your back straight.**

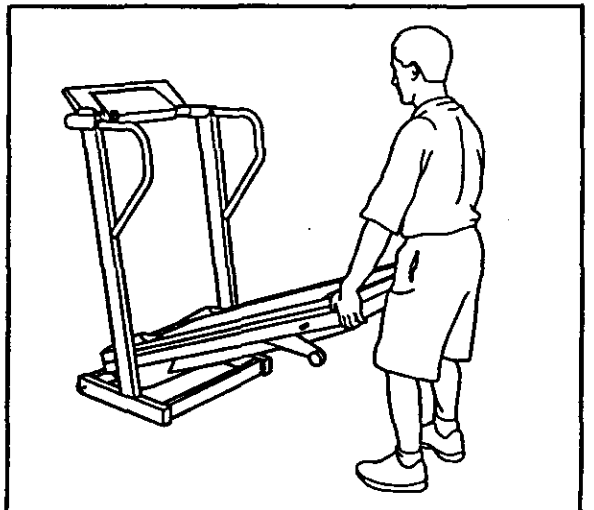
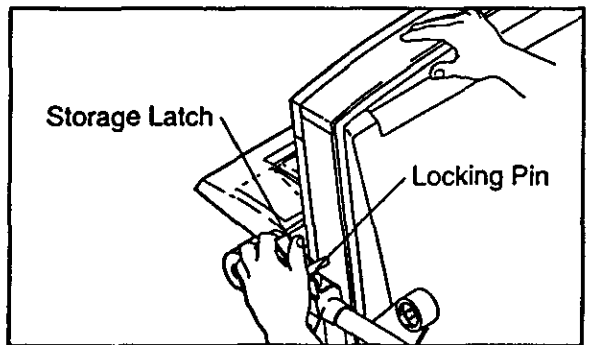

TROUBLE-SHOOTING AND STORAGE

Most treadmill problems can be solved by following the simple steps below. Find the symptom that applies, and follow the steps listed. If further assistance is needed, call our toll-free HELPLINE at 1-800-736-6879, Monday through Saturday, 7 a.m. until 7 p.m. Central Time (excluding holidays).

1. SYMPTOM: THE POWER DOES NOT TURN ON

- a. Make sure that the power cord is plugged into a surge protector, and that the surge protector is plugged into a properly grounded outlet. (See HOW TO PLUG IN THE POWER CORD on page 7.) Use only a UL-listed surge protector, rated at 15 amps, with a 14-gauge cord of five feet or less in length.
- b. After the power cord has been plugged in, make sure that the key is fully inserted into the console. Various indicators on the console should light. (See step 1 page 8.)
- c. Check the circuit breaker located on the treadmill near the power cord. If the switch protrudes as shown, the circuit breaker has tripped. To reset the circuit breaker, wait for five minutes and then press the switch back in.
- d. Check the on/off switch located at the front of the treadmill near the power cord. The switch must be in the "on" position.

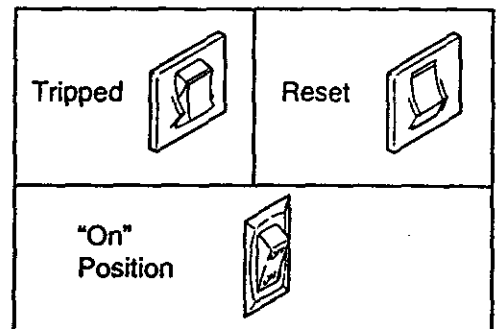

2. SYMPTOM: THE POWER TURNS OFF DURING USE

- a. Check the circuit breaker located on the treadmill frame near the power cord. If the circuit breaker has tripped (see the drawing above), wait for five minutes and then press the switch back in.
- b. Make sure that the power cord is plugged in.
- c. Remove the key from the console. Reinsert the key fully into the console. (See step 1 on page 8.)
- d. Check to make sure that the on/off switch is in the "on" position. (See 1. d. above.)
- e. If the treadmill still will not run, please call our toll-free HELPLINE.

3. SYMPTOM: THE WALKING BELT SLOWS WHEN WALKED ON

- a. Use only a UL-listed surge protector, rated at 15 amps, with a 14-gauge cord of five feet or less in length.
- b. If the walking belt still slows when walked on, please call our toll-free HELPLINE.

4. SYMPTOM: THE WALKING BELT IS OFF-CENTER OR SLIPS WHEN WALKED ON

- a. If the walking belt has shifted to the left, first remove the key and **UNPLUG THE POWER CORD**. Using the 3/16" allen wrench, turn the left rear roller adjustment bolt clockwise 1/4 of a turn. Plug in the power cord, insert the key and run the treadmill for a few minutes. Repeat until the walking belt is centered.

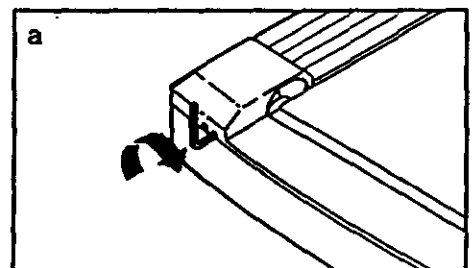

- b. If the walking belt has shifted to the right, first remove the key and **UNPLUG THE POWER CORD**. Using the 3/16" allen wrench, turn the left rear roller adjustment bolt counterclockwise 1/4 of a turn. Plug in the power cord, insert the key and run the treadmill for a few minutes. Repeat until the walking belt is centered.

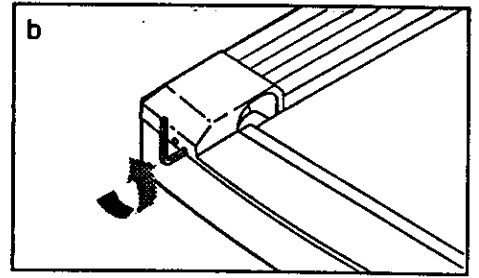

CONDITIONING GUIDELINES

⚠ WARNING: Before beginning this or any exercise program, consult your physician. This is especially important for individuals over the age of 35 or individuals with pre-existing health problems.

The pulse sensor is not a medical device. Various factors, including your movement, may affect the accuracy of heart rate readings. The sensor is intended only as an exercise aid in determining heart rate trends in general.

The following guidelines will help you to plan your exercise program. Remember—these are general guidelines. For more detailed information about exercise, obtain a reputable book or consult your physician.

EXERCISE INTENSITY

Whether you want to burn fat, strengthen your cardiovascular system, or increase your athletic performance, you can tailor your exercise to your specific goals. The key to achieving the desired results is to exercise with the proper intensity:

Burning Fat

To burn fat effectively, you must exercise at a relatively low intensity level for a sustained period of time. During the first few minutes of exercise, your body uses easily accessible *carbohydrate calories* for energy. Only after the first few minutes of exercise does your body begin to use stored *fat calories* for energy. If your goal is to burn fat, set the speed control on the console to FAT BURN to help you maintain the proper intensity level. (See pages 8 and 9.)

Aerobic Exercise

If your goal is to strengthen your cardiovascular system, your exercise must be "aerobic." Aerobic exercise is activity that requires large amounts of oxygen for prolonged periods of time. This increases the demand on the heart to pump blood to the muscles, and on the lungs to oxygenate the blood. The proper intensity level for aerobic exercise can be found by using your pulse as a guide. As you exercise, your pulse should be kept at a level between 70% and 85% of your maximum possible heart rate. This is known as your training zone. You can find your training zone in the table at the top of this page. Training zones are listed according to age and physical condition.

| Age | Training Zone (Beats/Min.) | |
|-----|----------------------------|-------------|
| | Unconditioned | Conditioned |
| 20 | 138-167 | 133-162 |
| 25 | 136-166 | 132-160 |
| 30 | 135-164 | 130-158 |
| 35 | 134-162 | 129-156 |
| 40 | 132-161 | 127-155 |
| 45 | 131-159 | 125-153 |
| 50 | 129-156 | 124-150 |
| 55 | 127-155 | 122-149 |
| 60 | 126-153 | 121-147 |
| 65 | 125-151 | 119-145 |
| 70 | 123-150 | 118-144 |
| 75 | 122-147 | 117-142 |
| 80 | 120-146 | 115-140 |
| 85 | 118-144 | 114-139 |

keep your pulse near the low end of your training zone as you exercise. After a few months of regular exercise, your pulse can be gradually increased until it is near the middle of your training zone as you exercise. You can measure your pulse using the pulse sensor. Exercise for about four minutes, and then measure your pulse immediately. If your pulse is too high or too low, adjust the intensity of your exercise. It may also be helpful to set the speed control on the console to AEROBIC to help you maintain the proper intensity level. (See pages 8 and 9.)

Performance Training

If your goal is high performance athletic conditioning, set the speed control on the console to PERFORMANCE to help you maintain the proper intensity level. (See pages 8 and 9.)

WORKOUT GUIDELINES

Each workout should include three parts: (1) a warm-up, (2) training zone exercise, and (3) a cool-down.

Warm-up

Warming up prepares the body for exercise by increasing circulation, delivering more oxygen to the muscles and raising the body temperature. Begin each workout with 5 to 10 minutes of stretching and light exercise to warm up (see SUGGESTED STRETCHES on page 15).

Training Zone Exercise

After warming up, increase the intensity of your exercise until your pulse is in your training zone for 20 to 60 minutes. (During the first few weeks of your exercise program, do not keep your pulse in your training zone for longer than 20 minutes.) Breathe regularly and deeply as you exercise—never hold your breath.

Cool-down

Finish each workout with 5 to 10 minutes of stretching

to cool down. This will increase the flexibility of your muscles and will help to prevent post-exercise problems.

Exercise Frequency

To maintain or improve your condition, complete three workouts each week, with at least one day of rest between workouts. After a few months, you may complete up to five workouts each week if desired.

The key to success is to make exercise a regular and enjoyable part of your everyday life.

SUGGESTED STRETCHES

The correct form for several basic stretches is shown in the drawings below. Move slowly as you stretch—never bounce.

1. Toe Touch Stretch

Stand with your knees bent slightly and slowly bend forward from your hips. Allow your back and shoulders to relax as you reach down toward your toes as far as possible. Hold for 15 counts, then relax. Repeat 3 times. Stretches: Hamstrings, back of knees and back.

2. Hamstring Stretch

Sit with one leg extended. Bring the sole of the opposite foot toward you and rest it against the inner thigh of your extended leg. Reach toward your toes as far as possible. Hold for 15 counts, then relax. Repeat 3 times for both legs. Stretches: Hamstrings, lower back and groin.

3. Calf/Achilles Stretch

With one leg in front of the other, reach forward and place your hands against a wall. Keep your back leg straight and your back foot flat on the floor. Bend your front leg, lean forward and move your hips toward the wall. Hold for 15 counts, then relax. Repeat 3 times for both legs. To cause further stretching of the achilles tendons, bend your back leg as well. Stretches: Calves, achilles tendons and ankles.

4. Quadriceps Stretch

With one hand against a wall for balance, reach back and grasp one foot with your other hand. Bring your heel as close to your buttocks as possible. Hold for 15 counts, then relax. Repeat 3 times for both legs. Stretches: Quadriceps and hip muscles.

5. Inner Thigh Stretch

Sit with the soles of your feet together and your knees outward. Pull your feet toward your groin area as far as possible. Hold for 15 counts, then relax. Repeat 3 times. Stretches: Quadriceps and hip muscles.

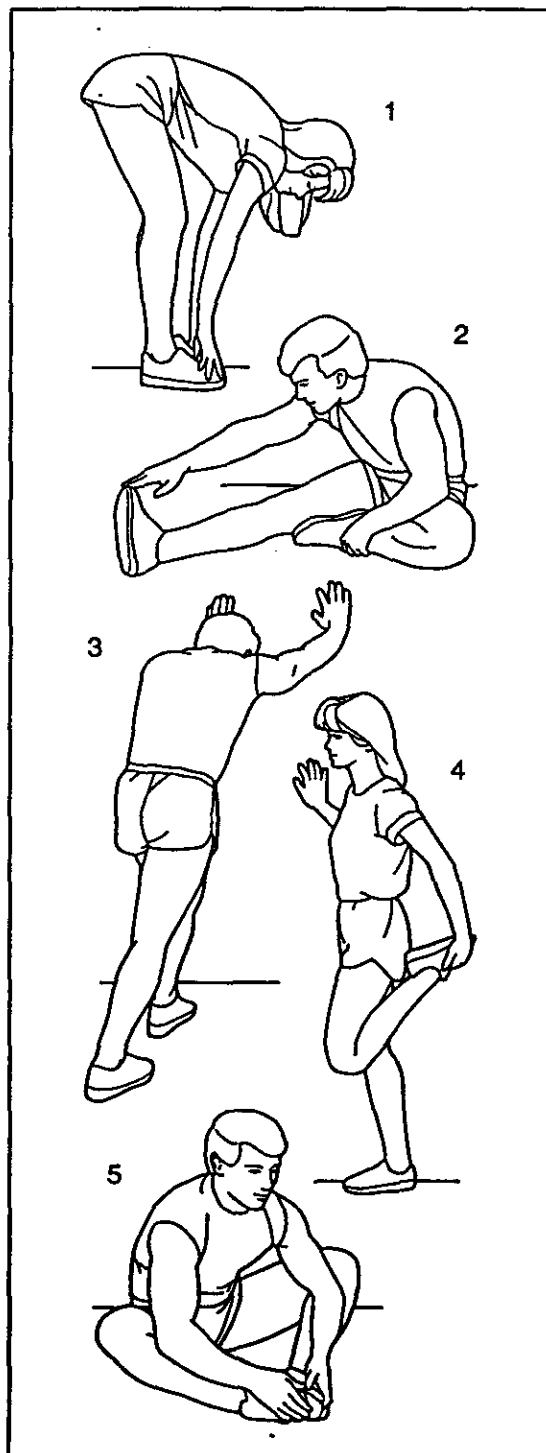

REMOVE THIS EXPLODED DRAWING AND PART LIST FROM THE MANUAL

Save this EXPLODED DRAWING and PART LIST for future reference.

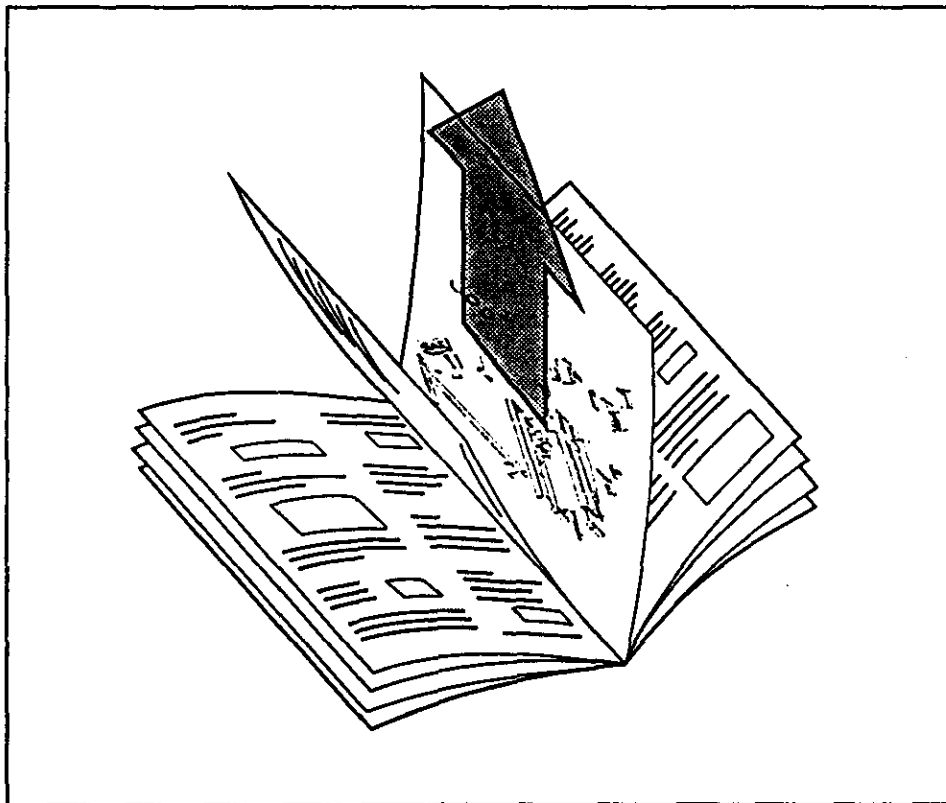

Note: Specifications are subject to change without notice. For information about ordering replacement parts, see the back cover of this manual.

PART LIST—Model No. 831.297642

R0196A

| Key No. | Part No. | Qty. | Description | Key No. | Part No. | Qty. | Description |
|---------|----------|------|-----------------------------|---------|----------|------|---------------------------------------|
| 1 | 119994 | 2 | Crossbar Bolt | 59 | 013375 | 1 | Incline Rod Bolt |
| 2 | 013282 | 8 | Console Bracket Screw | 60 | 114270 | 1 | Incline Motor Spacer |
| 3 | 127091 | 1 | Left Console Bracket | 61 | 126058 | 1 | Incline Motor |
| 4 | 013322 | 8 | Console Screw | 62 | 127672 | 1 | Incline Rod |
| 5 | 119038 | 1 | Key/Clip | 63 | 013544 | 2 | Incline Leg Bolt |
| 6 | 127739 | 1 | Left Upright | 64 | 014132 | 2 | Incline Leg Washer |
| 7 | 126775 | 1 | Wire Harness | 65 | 013399 | 2 | Incline Leg Wheel Bolt |
| 8 | 128265 | 2 | Cable Loom | 66 | 052012 | 2 | Incline Leg Wheel |
| 9 | 128477 | 1 | Console Crossbar | 67 | 012149 | 6 | Incline Leg Nut |
| 10* | 127984 | 1 | Console | 68 | 126735 | 1 | Incline Leg |
| 11 | 105477 | 2 | Motor Nut | 69 | 128260 | 1 | Right Rear Adjustment Bolt |
| 12 | 127089 | 1 | Motor | 70 | 119425 | 4 | Base Crossbar Nut |
| 13 | 126747 | 1 | Pulley/Flywheel/Fan | 71 | 114009 | 4 | Base Crossbar Bolt |
| 14 | 117806 | 2 | Wheel Bolt | 72 | 125758 | 1 | Rear Hood |
| 15 | 126134 | 1 | Motor Belt | 73 | 126729 | 2 | Base Crossbar |
| 16 | 013547 | 1 | Motor Tension Bolt | 74 | 105444 | 1 | Left Rear Adjustment Bolt |
| 17 | 122812 | 1 | Motor Tension Washer | 75 | 127009 | 1 | Rear Roller |
| 18 | 014117 | 1 | Motor Tension Star Washer | 76 | 128986 | 1 | Rear Roller Tension Spring |
| 19 | 100994 | 2 | Motor Bolt | 77 | 123470 | 1 | Spring Sleeve |
| 20 | 120867 | 1 | Motor Tension Nut | 78 | 119439 | 1 | Roller Tension Nut |
| 21 | 127692 | 1 | Front Hood | 79 | 125860 | 1 | Rear Roller Guard |
| 22 | 120785 | 1 | Motor Mount Bracket | 80 | 116586 | 8 | Hood Screw |
| 23 | 107503 | 1 | Motor Swivel Bolt | 81 | 127544 | 2 | Guard Spring |
| 24 | 117882 | 1 | Reed Switch/Wire | 82 | 100691 | 8 | Platform Screw |
| 25 | 100498 | 1 | Magnet | 83 | 126040 | 1 | 3/16" Allen Wrench |
| 26 | 016028 | 2 | Adhesive Clip | 84 | 013141 | 4 | Crossbar Screw |
| 27 | 120630 | 16 | Screw | 85 | 016057 | 5 | 8" Wire Tie |
| 28 | 054023 | 3 | Wire Clip | 86 | 116927 | 2 | Tie Holder Clamp |
| 29 | 127419 | 4 | Hood Anchor | 87 | 109382 | 1 | Circuit Breaker |
| 30 | 119163 | 1 | On/Off Switch | 88 | 127741 | 1 | Right Upright |
| 31 | 126910 | 1 | Electronics Bracket | 89 | 045017 | 1 | 7/32" Allen Wrench |
| 32 | 127847 | 1 | Controller | 90 | 125871 | 1 | Motor Controller Wire |
| 33 | 128903 | 1 | Power Board w/Stand-Off | 91 | 110722 | 2 | Upright Endcap |
| 34 | 109365 | 1 | Choke | 92 | 126641 | 1 | Water Bottle Insert |
| 35 | 015071 | 4 | Plastic Stand-off | 93 | 112628 | 4 | Wheel Spacer |
| 36 | 126641 | 1 | Right Console Bracket | 94 | 013300 | 12 | Anchor Screw |
| 37 | 112609 | 1 | Front Roller Adj. Bolt | 95 | 126650 | 4 | Upright Foot |
| 38 | 014127 | 5 | Adjustment Washer | 96 | 126960 | 1 | Upright Plug |
| 39 | 124669 | 1 | Power Cord | 97 | 111869 | 2 | Crossbar Cage Nut |
| 40 | 124695 | 1 | Grommet | 98 | 126845 | 1 | Safety Cover Grommet |
| 41 | 126457 | 1 | Safety Cover Wire Harness | 99 | 014086 | 2 | Console Bracket Washer |
| 42 | 113203 | 1 | Safety Cover Cable Loom | 100* | 127090 | 1 | Motor/Pulley/Flywheel/Fan |
| 43 | 126730 | 1 | Safety Cover | 101 | 128254 | 1 | Speed Control |
| 44 | 013162 | 22 | Safety Cover Screw | 102 | 128465 | 2 | Crossbar Bracket |
| 45 | 129022 | 1 | Front Roller/Pulley | 103 | 013540 | 4 | Crossbar Screw |
| 46 | 127698 | 1 | Walking Platform w/Fastener | # | 127860 | 12 | Fastener |
| 47 | 127699 | 1 | Walking Belt w/Fastener | # | 124768 | 1 | 14" White Wire, 2 Female |
| 48 | 127700 | 2 | Foot Rail w/Fastener | # | 107771 | 1 | 8" White Wire, Male/Female |
| 49 | NSP | 1 | Frame | # | 102634 | 1 | 8" Green Ground Wire |
| 50 | 112669 | 2 | Hair Pin Cotter | # | 109407 | 1 | 4" Black Wire, 2 Female |
| 51 | 108204 | 2 | Cotter Pin | # | 112083 | 1 | 8" Blue Wire, 2 Female |
| 52 | 127098 | 2 | Belt Guide | # | 114953 | 1 | 14" Blue Wire, 2 Female |
| 53 | 118570 | 2 | Upright Pivot Washer | # | 124770 | 0 | 8" White Wire, Male/Female (not used) |
| 54 | 113204 | 0 | Cable Loom (see 8) | # | 127998 | 1 | User's Manual |
| 55 | 012056 | 2 | Wheel Nut | | | | |
| 56 | 126635 | 2 | Upright Pivot Bolt | | | | |
| 57 | 125802 | 4 | Rubber Hood Anchor | | | | |
| 58 | 052014 | 2 | Front Wheel | | | | |

* Includes all the parts shown in the the box.

Indicates a non-illustrated part.

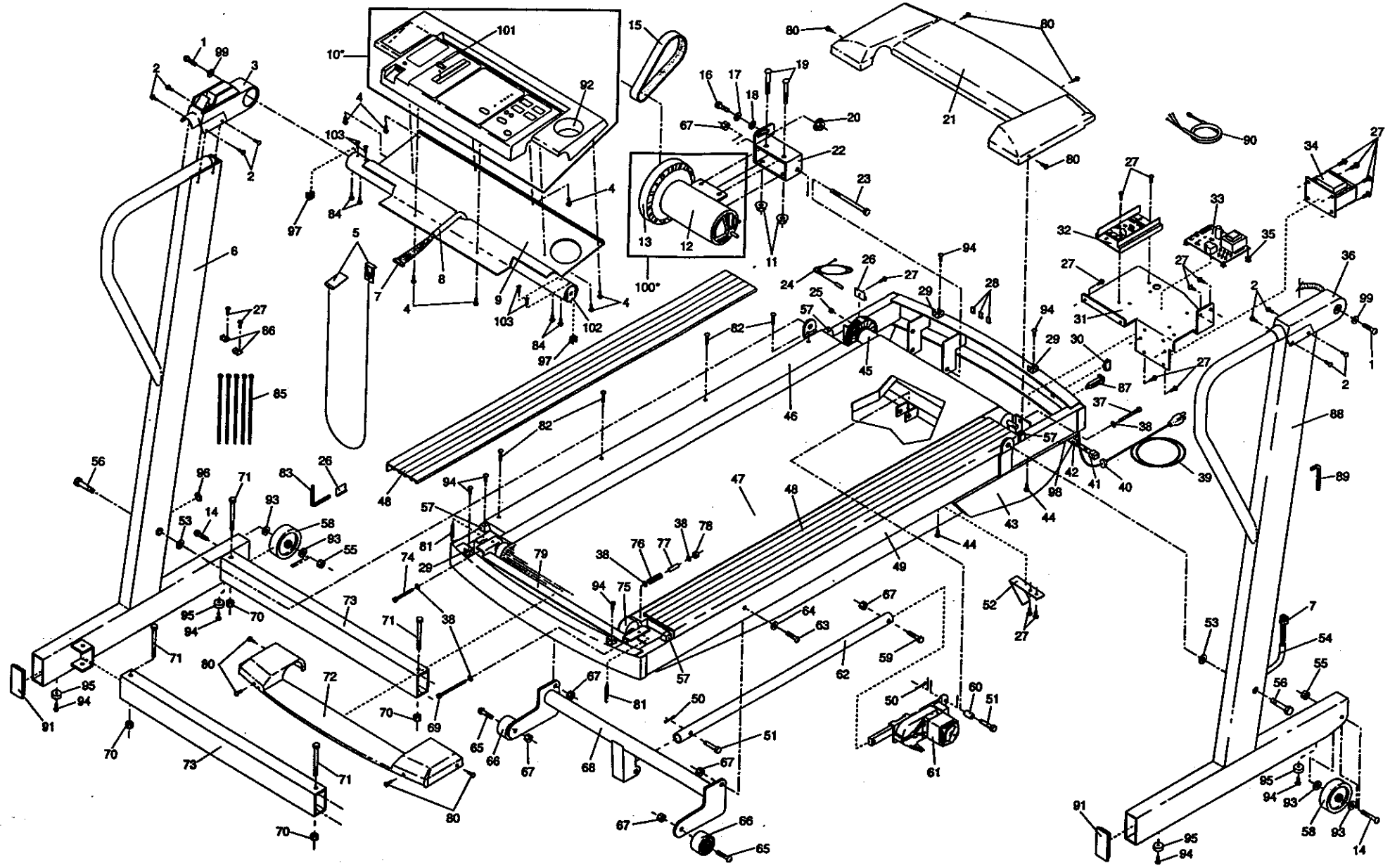

SEARS

Model No. 831.297642

QUESTIONS?

If you find that:

- you need help assembling or operating the PROFORM® 580si treadmill
- a part is missing
- or you need to schedule repair service

call our toll-free HELPLINE

1-800-736-6879

Monday-Saturday, 7 am-7 pm
Central Time (excluding holidays)

REPLACEMENT PARTS

If parts become worn and need to be replaced, call the following toll-free number

1-800-FON-PART
(1-800-366-7278)

The model number and serial number of your PROFORM® 580si treadmill are listed on a decal attached to the frame. See the front cover of this manual to find the location of the decal.

All replacement parts are available for immediate purchase or special order when you visit your nearest SEARS Service Center. To request service or to order parts by telephone, call the toll-free numbers listed at the left.

When requesting help or service, or ordering parts, please be prepared to provide the following information:

- The NAME OF THE PRODUCT (PROFORM® 580si treadmill)
- The MODEL NUMBER OF THE PRODUCT (831.297642)
- The PART NUMBER OF THE PART (see the EXPLODED DRAWING and PART LIST attached to the center of this manual)
- The DESCRIPTION OF THE PART (see the EXPLODED DRAWING and PART LIST attached to the center of this manual)

SEARS, ROEBUCK AND CO., HOFFMAN ESTATES, IL 60179 USA