

PRO-FORM[®]

CROSS TRAINER e[®]

MODEL NO. 831.159340

WEIGHT SYSTEM • STAIR CLIMBER

PERSONAL TRAINER™

ELECTRONIC WORKOUT INSTRUCTION

OWNER'S MANUAL

ASSEMBLY

OPERATION

EXERCISE GUIDE

MAINTENANCE

PARTS

WARRANTY

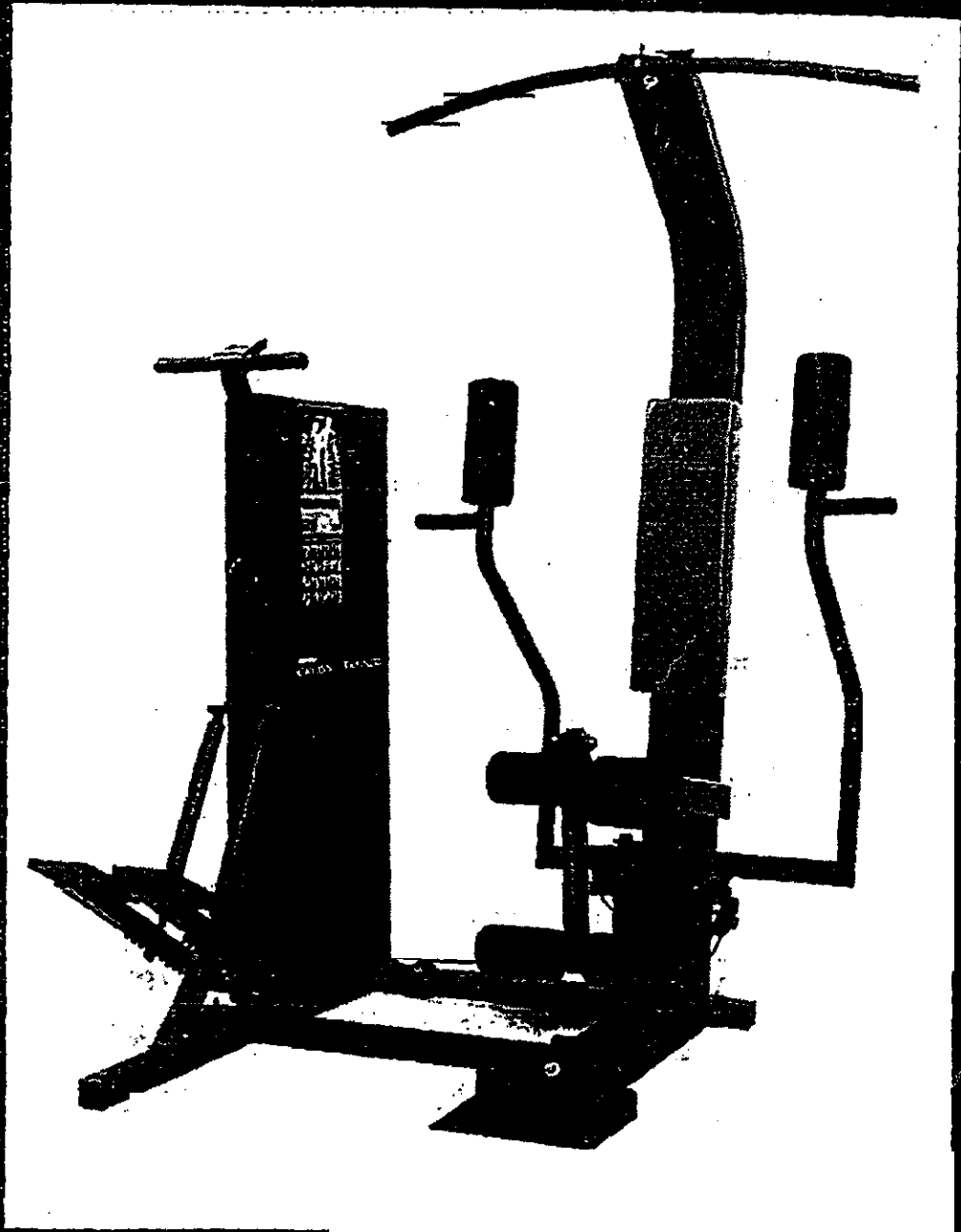

SEARS[®]

WARNING: Read this owner's manual carefully before using the CROSS TRAINER e.

TABLE OF CONTENTS

IMPORTANT SAFETY PRECAUTIONS	1
BEFORE YOU BEGIN	2
ASSEMBLY	3
ADJUSTING THE CROSS TRAINER e	8
TROUBLE-SHOOTING AND MAINTENANCE	9
OPERATING THE STEPPER CONSOLE	11
OPERATING THE PERSONAL TRAINER COMPUTER	12
Calories	13
EXERCISE GUIDE	16
PART LIST	25
EXPLODED DRAWING	26
ORDERING REPLACEMENT PARTS	Back Cover
LIMITED WARRANTY	Back Cover

IMPORTANT SAFETY PRECAUTIONS

WARNING: To reduce the risk of serious injury, read the following important safety precautions before using the CROSS TRAINER e. Before beginning any exercise program, consult your physician. This is especially important for persons over the age of 35 or persons with pre-existing health problems. SEARS assumes no responsibility for personal injury or property damage sustained by or through the use of this product.

1. Read this owner's manual and the accompanying FITNESS JOURNAL carefully before using the CROSS TRAINER e. Use the CROSS TRAINER e only as described.
2. Inspect and tighten all parts each time you use the CROSS TRAINER e. Replace any worn parts immediately.
3. Do not use the transformer if it is damaged. Keep the power cord away from walkways and heated surfaces.
4. Keep your hands away from moving parts. Always wear athletic shoes for foot protection.
5. Keep small children away from the CROSS TRAINER e at all times.
6. To prevent damage to the weight system, do not put any pressure on the leg developer, arms or cables while the weight setting is changing. If the lat bar or rower bar is attached to the high pulley station, rest it in the rack near the high pulley station. (See OPERATING THE PERSONAL TRAINER COMPUTER on page 12 of this owner's manual).
7. Always stand on the foot plate when performing any exercise that could cause the CROSS TRAINER e to tip.
8. Make sure that the cables remain in the grooves in the pulleys as you use the CROSS TRAINER e.
9. The resistance cylinders become very hot during use. Allow the resistance cylinders to cool before touching them. Cover the floor beneath the stepper for protection; a small amount of oil leakage is normal for hydraulic cylinders. When using the stepper, keep your feet on the pedals at all times. If you lift your feet off the pedals, the pedals may become separated from the resistance cylinders, resulting in injury.
10. If you feel pain or dizziness at any time while exercising, stop immediately and begin cooling down. Find out what is wrong before continuing.

RE YOU BEGIN

...ions for purchasing the revolutionary PROFORM® CROSS TRAINER e. The CROSS TRAINER e combines c
...ation weight system with a full-size stepper to let you enjoy true cross training workouts in the convenience of
...our own home. And to help you get the most from every workout, the CROSS TRAINER e features the advanced PER-
SONAL TRAINER™ weight training computer. Whether your goal is improved cardiovascular fitness, a shapely, toned
body or dramatic muscle size and strength, the CROSS TRAINER e will help you to achieve the specific results you want.

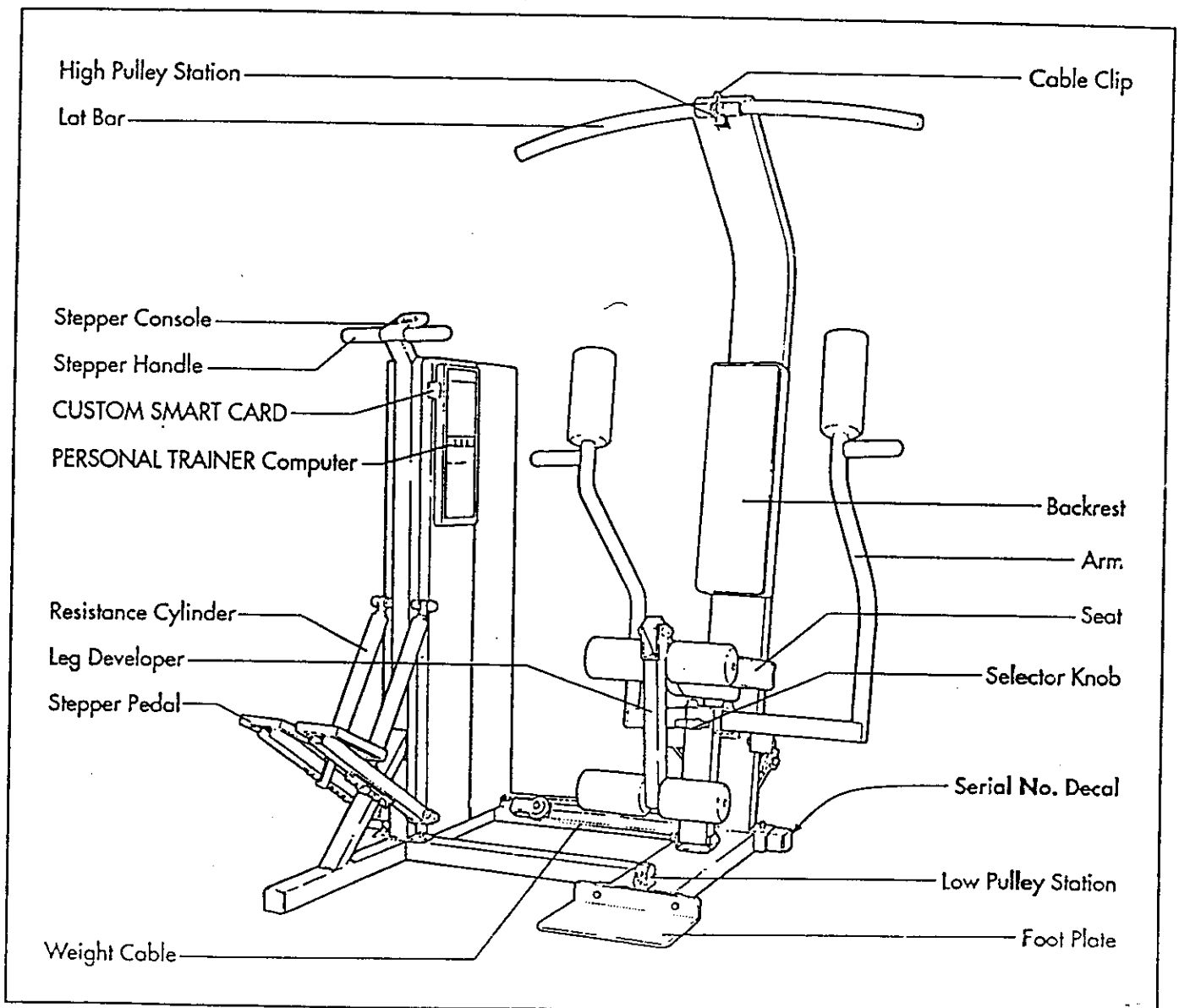

For your safety and benefit, read this owner's manual and the accompanying FITNESS JOURNAL carefully before using
the CROSS TRAINER e. If you have additional questions, please call our Customer Service Department toll-free at
1-800-999-3756, Monday through Friday, 6 a.m. until 6 p.m. Mountain Time (excluding holidays). To help us assist
you quickly, please note the model number and serial number of your CROSS TRAINER e before calling. The model
number is 831.159340. The serial number can be found on a decal attached to the CROSS TRAINER e. The location of
the decal is shown in the drawing below. Write the serial number in the following space for reference: _____.

Before reading further, please review the drawing below and familiarize yourself with the parts that are labeled.

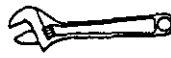

ASSEMBLY

Assembly requires two persons. To assemble the CROSS TRAINER e, use the included videocassette or follow the instructions below. Due to the weight of the CROSS TRAINER e, it should be assembled in the location where it will be used. Place all parts in a cleared area and remove the packing materials. Do not dispose of the packing materials until assembly is completed. Make sure to lower the resistance cylinders and pedals before beginning assembly; if the resistance cylinders fall, they may damage the side shields. Read each assembly step and examine each drawing carefully. Make sure that all parts are oriented as shown in the drawings.

The following tools (not included) are required for assembly: two 8" Adjustable Wrenches  and a Rubber Mallet . The included lubricant and a small amount of soapy water are also required.

1. Set the Front Base (7) and the Rear Base (8) on the floor as shown. Turn the Rear Base so the indented holes are toward the floor.

Insert seven $3/8"$ x $2 1/2"$ Carriage Bolts (1) up through the indicated holes in the Front and Rear Bases (7, 8).

2. With the help of a second person, set the Tower Frame (10) near the indicated ends of the Front and Rear Bases (7, 8). The Tower Frame must be turned so the Pedals (75, 76) are on the same side as the extension on the Front Base. Raise the Tower Frame and lower it onto the two indicated $3/8"$ x $2 1/2"$ Carriage Bolts (1) in the Rear Base.

3. Raise the front of the Tower Frame (10) and lower it onto the two indicated $3/8"$ x $2 1/2"$ Carriage Bolts (1) in the Front Base (7).

Adjust the position of the Tower Frame (10) so the four indicated $3/8"$ x $2 1/2"$ Carriage Bolts (1) are centered in the slotted holes in the Tower Frame. Thread a $3/8"$ Nut (2) with a $3/8"$ Lockwasher (3) onto each Carriage Bolt. Do not tighten the Nuts yet.

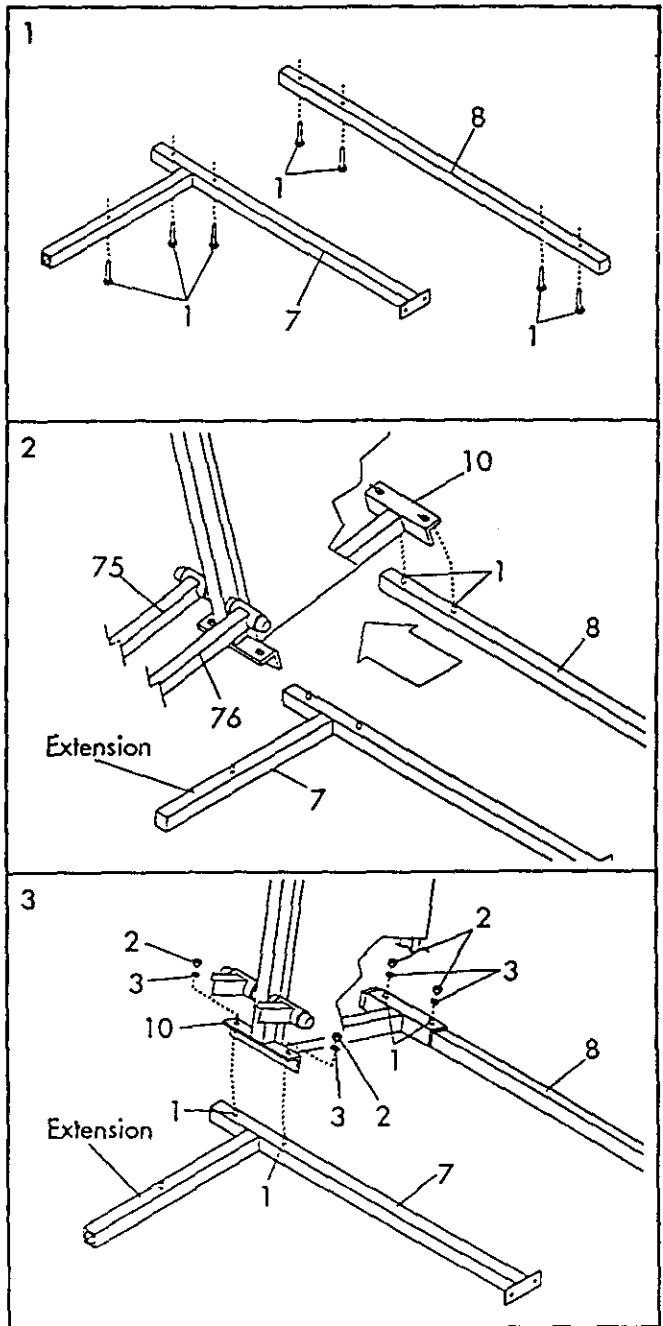

- Slide the Brace (29) onto the threaded bolt protruding from the Tower Frame (10). Thread a 3/8" Nylock Nut (6) onto the threaded bolt. Do not tighten the Nylock Nut yet.

Place your foot on the extension and slightly raise the front of the Tower Frame (10). Align the lower end of the Brace (29) with the indicated 3/8" x 2 1/2" Carriage Bolt (1). Lower the Tower Frame so the Brace slides onto the Carriage Bolt. Thread a 3/8" Nut (2) with a 3/8" Lockwasher (3) onto the Carriage Bolt. Do not tighten the Nut yet.

- With the help of a second person, lift the Upright (9) and lower it onto the two indicated 3/8" x 2 1/2" Carriage Bolts (1) in the Rear Base (8). Thread a 3/8" Nut (2) and 3/8" Lockwasher (3) onto each Carriage Bolt. Do not tighten the Nuts yet.

Attach the Front Base (7) to the Upright (9) with two 3/8" x 3/4" Bolts (31).

Tighten the 3/8" Nylock Nut (6) attached in assembly step 4, and the seven 3/8" Nuts (2) attached in assembly steps 3 through 5.

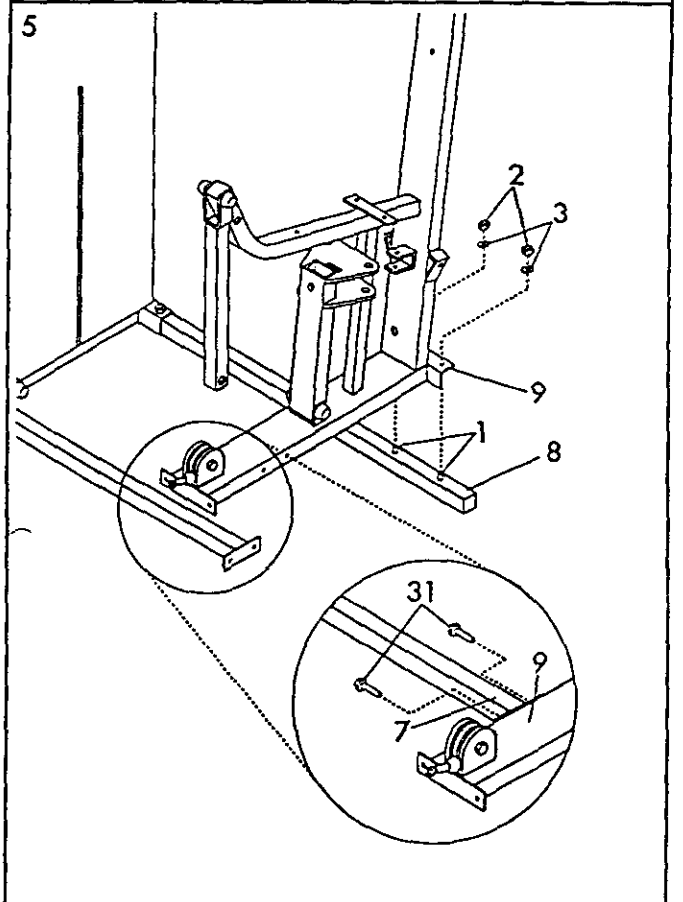
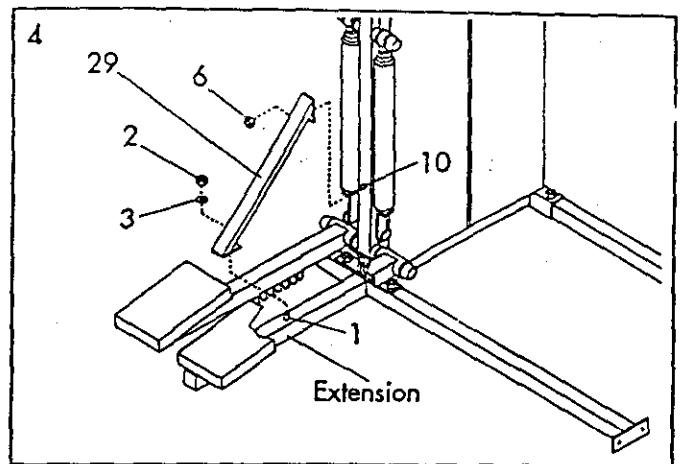

- Attach the Foot Plate (102) to the Upright (9) with two 3/8" x 3/4" Bolts (31) and 3/8" Nylock Nuts (6).

With the help of a second person, lift the Front Base (7). Peel the backing off three Rubber Pads (48). Press two onto the underside of the Front Base in the indicated locations, and one onto the underside of the Upright (9). Lower the Front Base.

Press two Rubber Pads (48) onto the Rear Base (8) in the same manner.

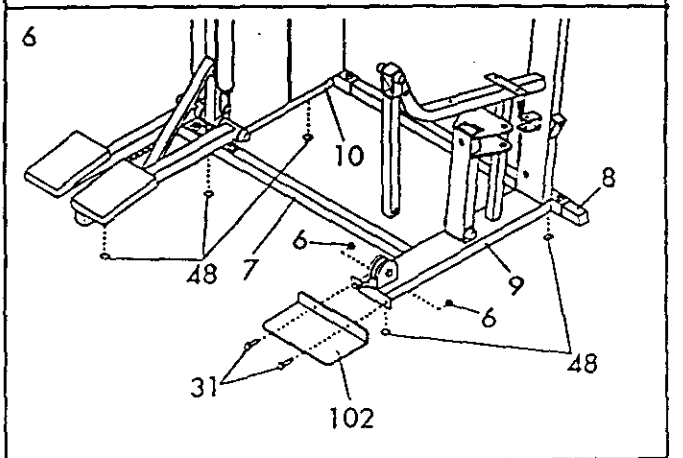

7. Insert the lower end of the Left Arm (15) into the left side of the Moment Arm (74). Make sure that the bracket on the end of the Left Arm is positioned as shown in the inset drawing. If the bracket is not positioned as shown, the Left Arm will not function properly.

Align the hole in the end of the Left Arm (15) with the holes in the Moment Arm (74). Insert the 3/4" x 4" Axle (54) into the Moment Arm and the Left Arm. Tap a 3/4" Plastic Cap (57) onto the Axle.

Attach the Right Arm (16) in the same manner.

8. Wrap the Weight Cable (52) under a 3 1/2" Pulley (5). Attach the Pulley and a Cable Trap (67) to the back of the Upright (9) with a 3/8" x 1 3/4" Bolt (40) and 3/8" Nylock Nut (6). Make sure that the Cable Trap is in the "7 o'clock" position.

Lay the Weight Cable (52) over a 3 1/2" Pulley (5). Attach a Cable Trap (67) and the Pulley to the left side of the Upright (9) with a 3/8" x 1 3/4" Bolt (40) and 3/8" Nylock Nut (6). Make sure that the Cable Trap is in the "12 o'clock" position.

Wrap the Weight Cable (52) around a 2" Pulley (4). Attach the Pulley to the Left Arm (15) with a 3/8" x 1 3/4" Bolt (40) and 3/8" Nylock Nut (6).

9. Wrap the Weight Cable (52) around a 2 3/4" Pulley (13). Attach the Pulley to the indicated bracket on the Upright (9) with a 3/8" x 1 3/4" Bolt (40) and 3/8" Nylock Nut (6).

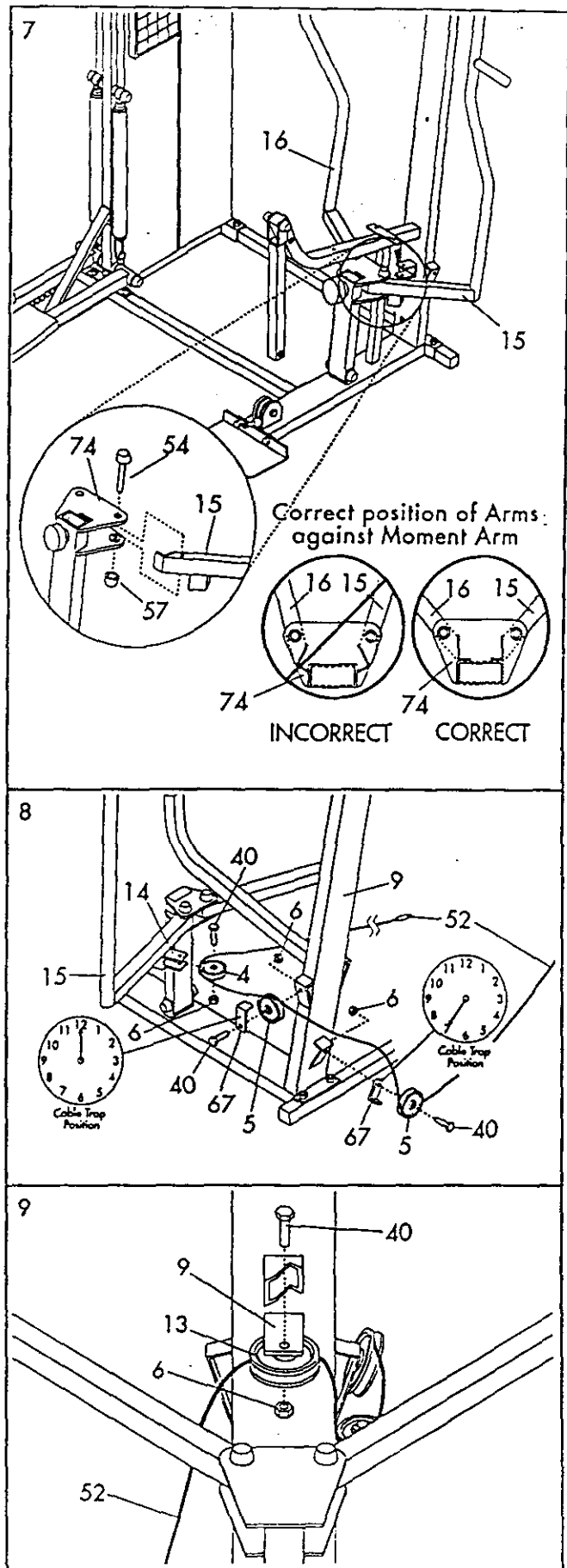

10. Wrap the Weight Cable (52) around a 2" Pulley (4). Attach the Pulley to the Right Arm (16) with a 3/8" x 1 3/4" Bolt (40) and 3/8" Nylock Nut (6).

Lay the Weight Cable (52) over a 3 1/2" Pulley (5). Attach a Cable Trap (67) and the Pulley to the side of the Upright (9) with a 3/8" x 1 3/4" Bolt (40) and 3/8" Nylock Nut (6). Make sure that the Cable Trap is in the "12 o'clock" position.

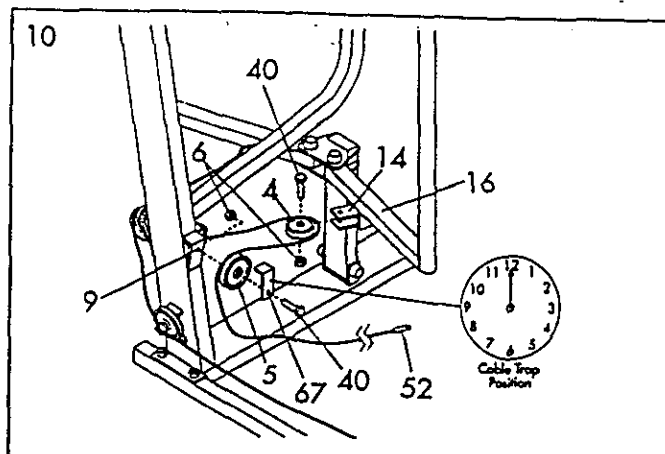

11. Wrap the Weight Cable (52) under a 2 3/4" Pulley (13). Attach the Pulley to the bracket on the side of the Moment Arm (74) with a 3/8" x 1 3/4" Bolt (40) and 3/8" Nylock Nut (6).

Attach the end of the Weight Cable (52) to the right side of the Leg Developer (23) with a 3/8" x 2" Bolt (45) and 3/8" Nylock Nut (6). Do not overtighten the Nylock Nut, the Cable must be able to swivel freely or it will be damaged.

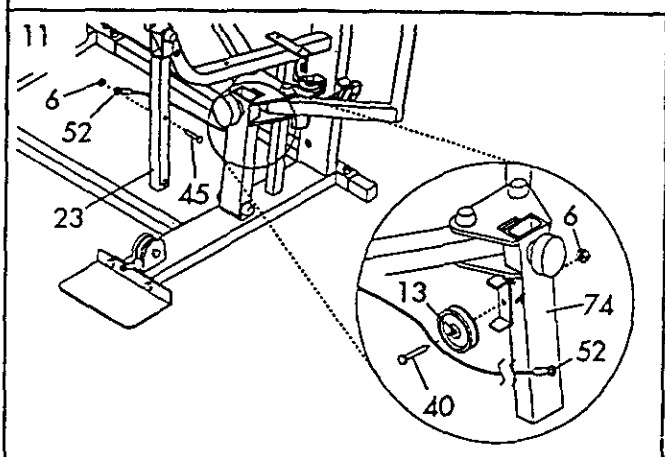

12. Insert the threaded bolt on the end of the Weight Cable (52) into the Adjustment Bracket (53). Thread the 5/16" Nut (82) exactly two complete turns onto the threaded bolt.

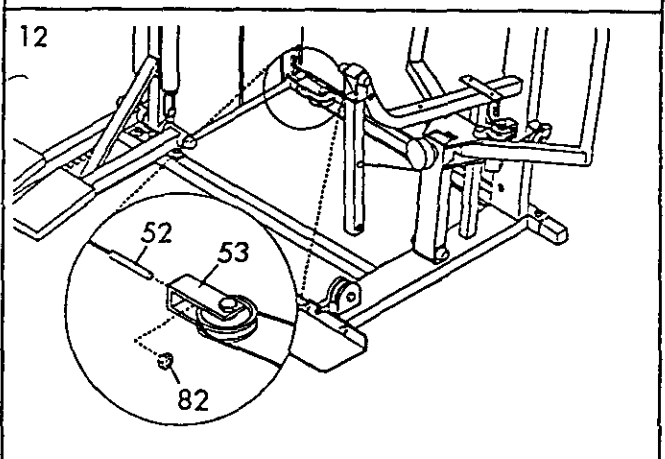

13. Wet the upper ends of the Left and Right Arms (15, 16) and the insides of the two Large Pads (17) with soapy water. Slide the Large Pads onto the Arms.

Attach the Backrest (19) to the Upright (9) with two 1/4" x 2 1/2" Bolts (46).

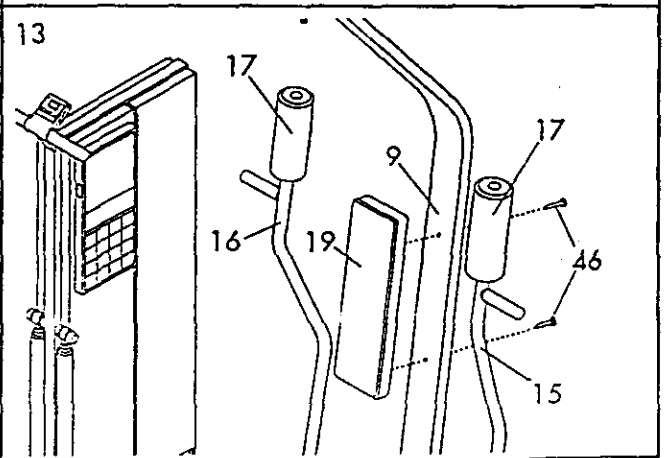

14. Attach the Seat (28) to the Upright (9) with the two 1/4" x 3/4" Bolts (20) and a 1/4" x 2 1/2" Bolt (46).

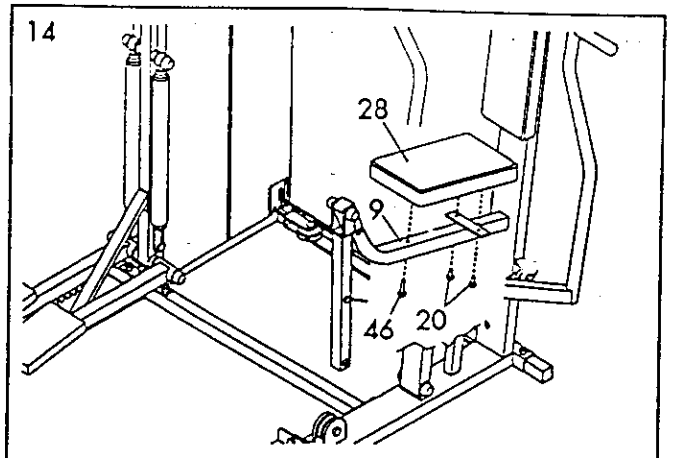

15. Center one Pad Tube (22) in the Upright (9), and the other Pad Tube in the Leg Developer (23). Slide the four Small Pads (17) onto the ends of the Pad Tubes.

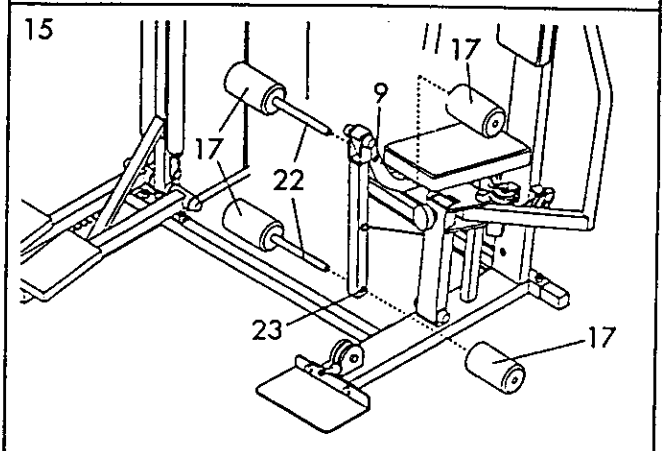

16. Rest the Left and Right Pedals (75, 76) on the hooks at the lower ends of the Resistance Cylinders (84). Make sure that the hooks are fully inserted into the same slots under both Pedals.

Plug the Transformer (39) into the jack located near the bottom of the Right Side Shield (12).

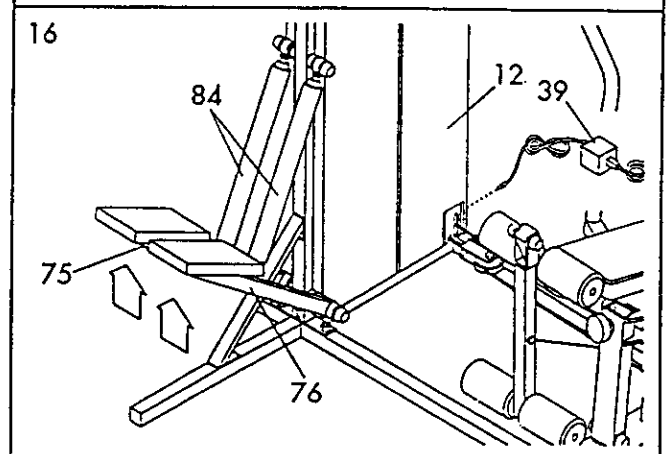

17. Make sure that all parts are properly tightened. The use of all remaining parts will be explained in ADJUSTING THE CROSS TRAINER e, beginning on page 8 of this owner's manual.
18. Before using the CROSS TRAINER e, test the cables and the pulleys. Make sure that the cables are in the grooves in the pulleys. If the cables do not move smoothly over the pulleys, locate and correct the problem before using the CROSS TRAINER e. If the cables are not properly routed, they will be damaged when used.

ADJUSTING THE CROSS TRAINER e

The CROSS TRAINER e is designed to be changed from station to station quickly and easily. The instructions below describe how each part of the CROSS TRAINER e can be adjusted. Please read these instructions carefully before using the CROSS TRAINER e. Refer to pages 17 through 24 of this owner's manual to see how the CROSS TRAINER e should be set up for each individual exercise.

IMPORTANT: For effective exercise, the CROSS TRAINER e must be set up correctly for each exercise. When attaching the lat bar, rower bar or strap, attach them directly to the CROSS TRAINER e or use the chain to attach them; make sure that the lat bar, rower bar or strap is in the correct starting position for each exercise. If there is any slack in the cable or chain as you perform an exercise, the effectiveness of the exercise will be reduced.

1. CHANGING THE STEPPING RESISTANCE

To change the resistance of the Pedals (75, 76), first lift the Pedals off the hooks at the lower ends of the Resistance Cylinders (84). Move the hooks to different slots under the Pedals. Make sure that the hooks are fully inserted into the same slots under both Pedals. The farther the hooks are from the Tower Frame (10), the greater the resistance will be. **WARNING:** The Resistance Cylinders become very hot during use. Allow the Resistance Cylinders to cool before touching them.

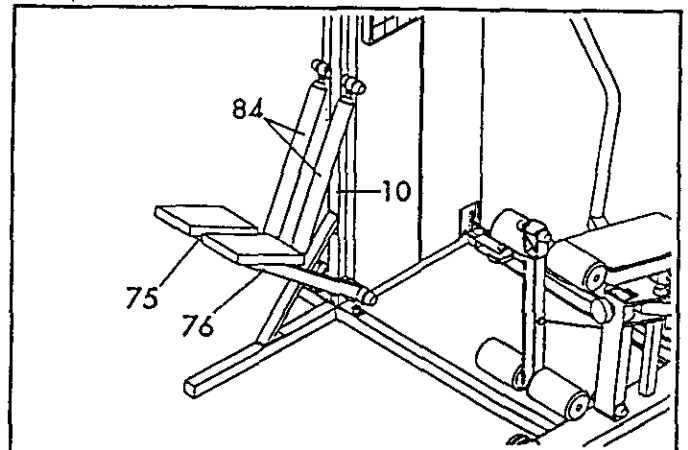

2. CHANGING THE ARMS TO THE BUTTERFLY MODE AND PRESS MODE

The Arms (15, 16) can be changed to either the butterfly mode or the press mode. To perform the BUTTERFLY exercise, change the Arms to the butterfly mode by turning the Selector Knob (55) so the Selector Plate (66) is vertical. To perform the BENCH PRESS exercise, change the Arms to the press mode by turning the Selector Knob so the Selector Plate is horizontal.

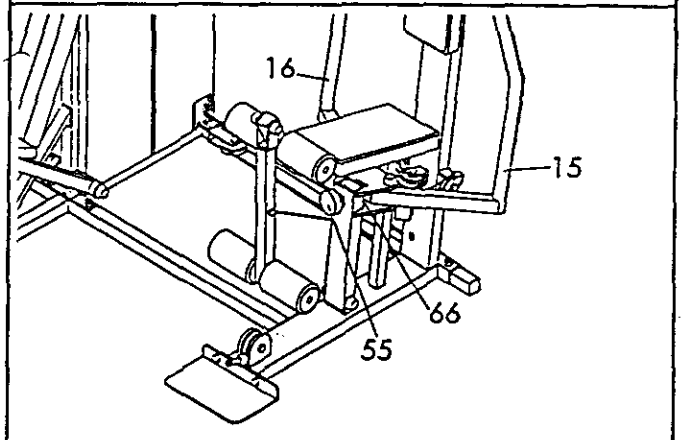

3. ATTACHING THE LAT BAR, ROWER BAR OR STRAP TO THE HIGH PULLEY STATION

Attach the Lat Bar (36) to the Main Cable (51) with a Cable Clip (33). For some exercises, the Chain (38) should be attached between the Lat Bar and the Main Cable with two Cable Clips. Adjust the length of the Chain between the Lat Bar and the Main Cable so the Lat Bar is in the correct starting position for the exercise to be performed.

The Rower Bar (34) or the Strap (35) can be attached in the same manner.

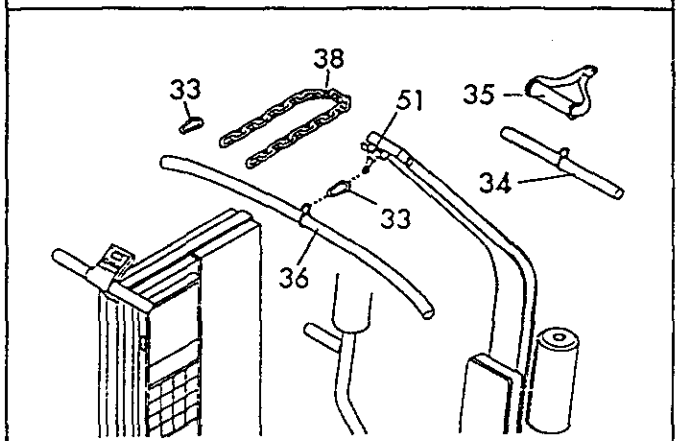

1. ATTACHING THE LAT BAR, ROWER BAR OR STRAP TO THE LOW PULLEY STATION

Attach the Lat Bar (36) to the Main Cable (51) with a Cable Clip (33). For some exercises, the Chain (38) should be attached between the Lat Bar and the Main Cable with two Cable Clips. Adjust the length of the Chain between the Lat Bar and the Main Cable so the Lat Bar is in the correct starting position for the exercise to be performed.

The Rower Bar (34) or the Strap (35) can be attached in the same manner.

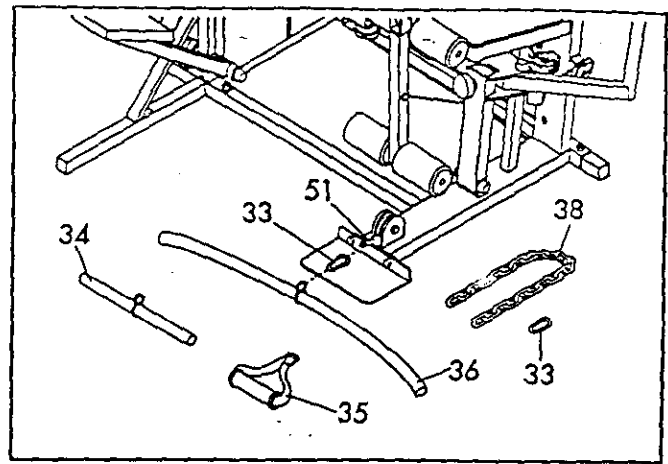

TROUBLE-SHOOTING AND MAINTENANCE

Inspect and tighten all parts each time you use the CROSS TRAINER e. Replace any worn parts immediately. Outside surfaces of the CROSS TRAINER e can be cleaned using a damp cloth and mild detergent. Keep all liquids away from the stepper console and the PERSONAL TRAINER computer.

Most CROSS TRAINER e problems can be solved by following the steps below. Find the applicable symptom and follow the step(s) listed. If further assistance is needed, call our Customer Service Department toll-free at 1-800-999-3756, Monday through Friday, 6 a.m. until 6 p.m. Mountain Time (excluding holidays).

1. SYMPTOM: THE POWER DOES NOT TURN ON

- Make sure that the transformer is fully plugged into the jack on the CROSS TRAINER e, and into a 120-volt outlet.

2. SYMPTOM: THE MAIN CABLE DOES NOT MOVE SMOOTHLY, OR THERE IS SLACK IN THE MAIN CABLE

- Inspect the routing of the cables and make sure that they are in the grooves in all of the pulleys. If they are not, correct the problem. If the cables are not properly routed, they will be damaged when used.

- If there is slack in the Main Cable (51), locate the Adjustment Bracket (53) near the bottom of the right side shield. Hold the end of the Weight Cable (52) firmly, and slide the Adjustment Bracket farther onto the Weight Cable. Tighten the 5/16" Nut (82) against the Adjustment Bracket. Test the Main Cable. If the motor stalls or hesitates, loosen the 5/16" Nut slightly. If the 5/16" Nut is tightened as far as possible and there is still slack, the Main Cable should be replaced. See ORDERING REPLACEMENT PARTS on the back cover of this owner's manual.

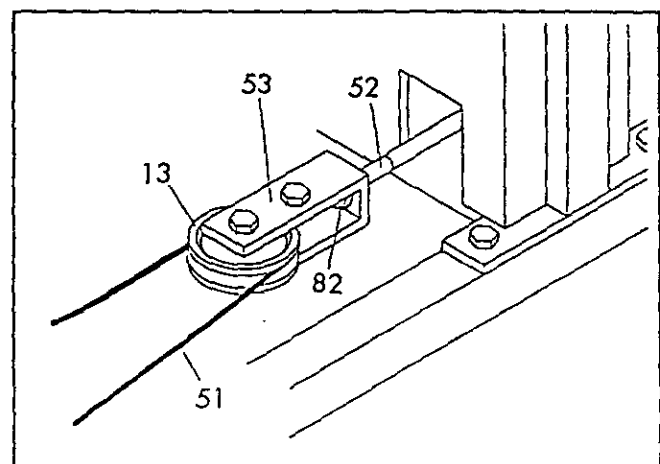

3. SYMPTOM: THE STEPPER CONSOLE DOES NOT FUNCTION PROPERLY

- a. As you step, move the stepper pedals vertically at least 8 inches. If your steps are too shallow, the movement of the stepper pedals will not be detected. If the stepper console still does not function properly, loosen the Reed Switch Screw (92). Hold down the Right Pedal (76). Adjust the position of the Reed Switch (99) so there is a $1/8$ " gap between the Reed Switch and the Magnet (81) on the Right Pedal. Tighten the Reed Switch Screw.

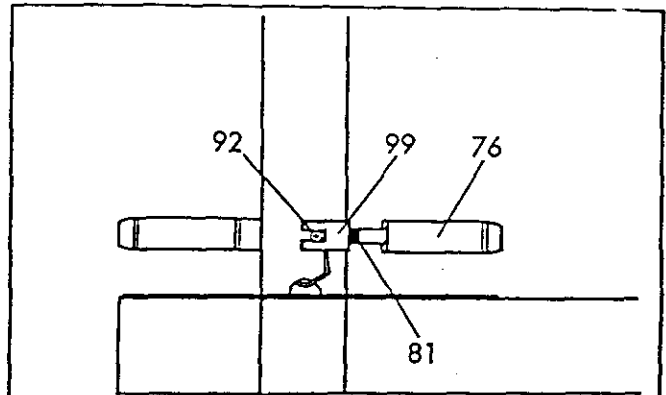

- b. If the LCD display becomes dim, the 1.5-volt watch batteries in the Stepper Console (88) should be replaced. Using a short phillips screwdriver, remove the two screws attaching the back of the Stepper Console. Using the screwdriver, carefully push the two batteries out of the battery clips; be careful to note which way the batteries are turned. Insert two new 1.5-volt watch batteries into the battery clips. Reattach the back of the Stepper Console.

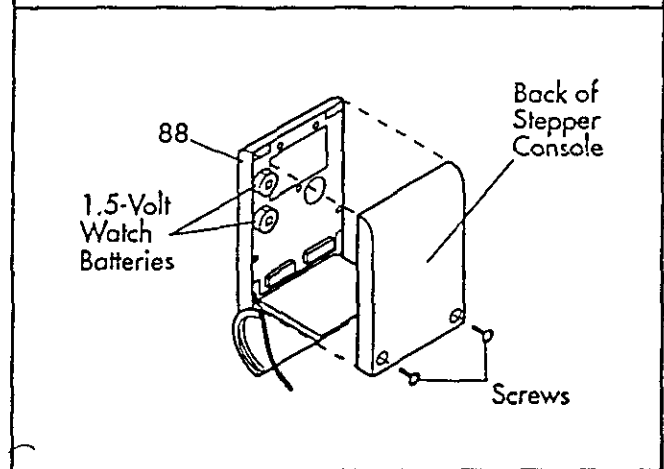

4. SYMPTOM: THE PERSONAL TRAINER COMPUTER DISPLAYS AN ERROR CODE ("EEE")

- a. While the weight setting is changing, the motor will be heard and the SETS and REPS displays will show a rapidly rotating indicator. To prevent damage to the weight system, do not put any pressure on the leg developer, arms or cables while the weight setting is changing. If the lat bar or rower bar is attached to the high pulley station, rest it in the rack near the high pulley station. Wait for the sound of the motor to stop before you continue. If the computer senses pressure on the weight system while the weight setting is changing, the WEIGHT display will show an error code ("EEE") for two seconds, and the weight setting will stop changing. The WEIGHT display will then show the current weight setting. Make sure that there is no pressure on the leg developer, arms or cables. Press the increase or decrease button beneath the WEIGHT display to change the weight setting as desired.

OPERATING THE STEPPER CONSOLE

The stepper console is designed to give you instant feedback as you exercise on the stepper. Please read these instructions carefully before operating the console. Note: Remove the clear plastic from the front of the console.

DIAGRAM OF THE CONSOLE

1. LCD display—Display for all modes.
2. Mode indicators—Show which mode is currently selected and displayed.
3. MODE button—Selects modes.
4. ON/OFF button—Turns the power on and off, and resets the display.

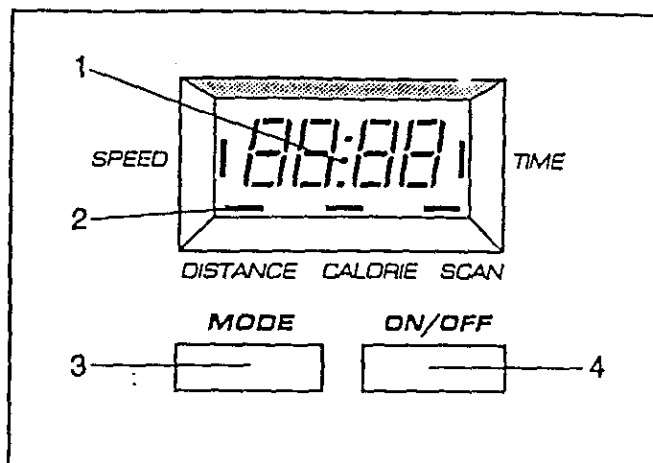

DESCRIPTION OF THE CONSOLE MODES

SPEED—Displays your stepping speed, in steps per minute.

TIME—Displays the length of time you have been stepping. Note: Time will be counted only while you are stepping. If you stop for ten seconds or longer, the TIME mode will pause until you resume stepping.

DISTANCE—Displays the total number of steps you have completed.

CALORIE—Displays the total number of Calories you have burned. Note: If the stepping resistance is near the lowest or highest setting, the actual number of Calories you have burned may be slightly lower or higher than the number displayed.

SCAN—Displays the SPEED, TIME, DISTANCE and CALORIE modes, for five seconds each, in a repeating cycle.

CONSOLE OPERATION

1. To turn on the power, press the ON/OFF button or simply begin stepping.
2. Select one of the five modes:
 - a. **SCAN**—When the power is turned on, the SCAN mode will be selected automatically. One mode indicator will appear by the word "SCAN." The SPEED, TIME, DISTANCE and CALORIE modes will all be displayed, for five seconds each, in a repeating cycle. A second mode indicator will show which mode is currently displayed.
 - b. **SPEED, TIME, DISTANCE or CALORIE**—The SPEED, TIME, DISTANCE or CALORIE mode can be selected for continuous display by repeatedly pressing the MODE button. The modes will be selected in the following order: SPEED, TIME, DISTANCE, CALORIE, SCAN.
3. To reset the LCD display, turn the power off and then on again by pressing the ON/OFF button twice.
4. When you are finished exercising, press the ON/OFF button to turn off the power. Note: If the pedals are not moved and the console buttons are not pressed for four minutes, the power will turn off automatically to conserve the batteries.

OPERATING THE PERSONAL TRAINER COMPUTER

The heart of the CROSS TRAINER e is the advanced PERSONAL TRAINER computer. With the PERSONAL TRAINER computer, you can change the weight setting with a touch of a button. As you exercise, the computer will measure your range of motion, show the number of Calories you have burned and keep track of the repetitions and sets you have completed. In the trainer mode, you can select a specific muscle group, and the computer will guide you through a series of exercises that will develop the selected muscle group. In the program mode, the included CUSTOM SMART CARD allow you to create custom exercise programs and store them in memory for future workouts. Preprogrammed SMART CARDS can also be purchased to help you achieve specific exercise goals. See the included brochure for more information. Please read these instructions carefully before operating the computer.

TURNING ON THE POWER

Plug the transformer into a 120-volt outlet. All indicators and displays on the computer will flash three times.

To turn on the power, press the POWER button. The four displays and various indicators on the computer will light. The system motor may be heard while the weight system recalibrates. **Note:** Always turn on the power when using the CROSS TRAINER e.

SELECTING THE TONE OR STRENGTH MODE

The PERSONAL TRAINER computer offers both a tone mode and a strength mode. If your goal is to tone your muscles and develop endurance, the tone mode should be selected. If you want to increase the size and strength of your muscles, the strength mode should be selected. When the power is turned on, the tone mode will be selected automatically. The tone indicator will light. To select the strength mode, press the STRENGTH button. The strength indicator will light.

USING THE MANUAL MODE

When the power is turned on, the computer will be in the manual mode. The lower part of the computer shows 20 exercises that can be performed on the CROSS TRAINER e. The indicator on exercise 1 will be flashing. Press the right or left arrow on the NEXT button until the indicator is flashing on the first exercise that you want to do. The number of the exercise that you select will be shown in the CALORIES/EXERCISE NO. display. **Note:** For help selecting an exercise, refer to the muscle chart on the upper part of the computer. Press on the muscle group that you want to exercise—be sure to press on the circled letter. As long as you continue to press on the muscle group, indicators will light on the lower part of the computer to show you which exercise(s) will develop the selected muscle group.

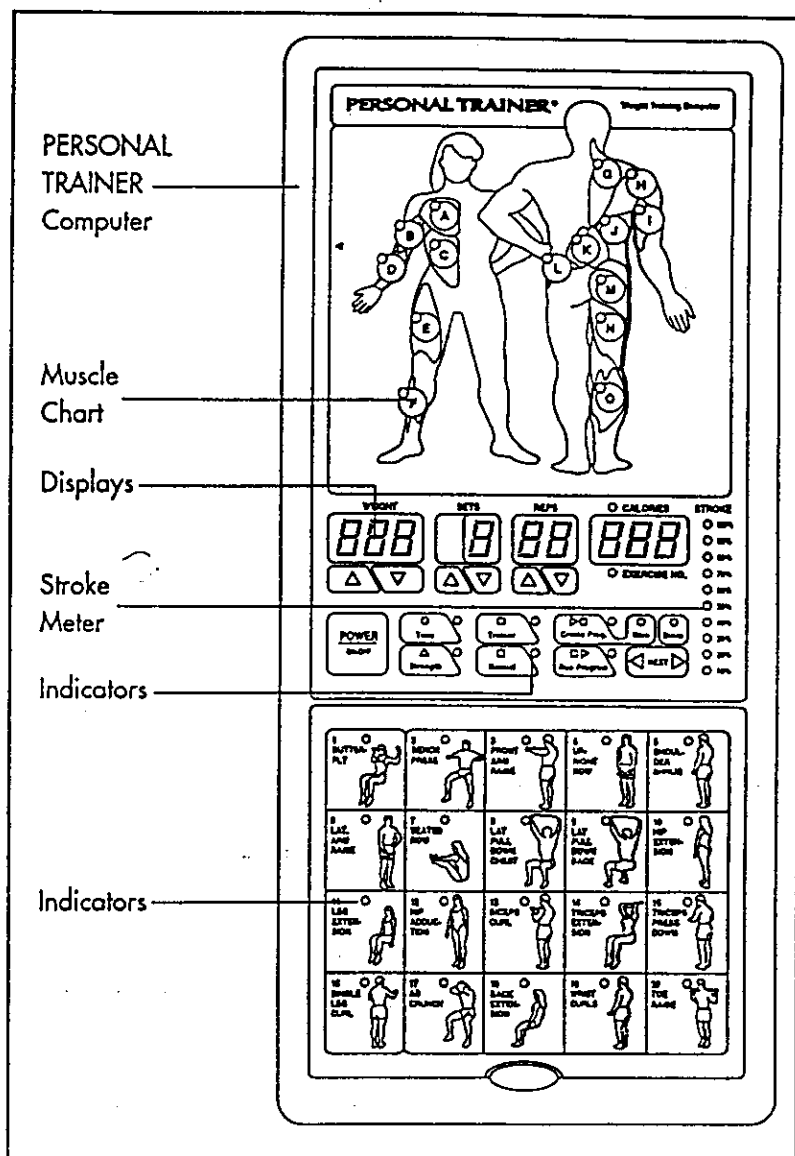

The WEIGHT display will show the recommended weight setting for the exercise that you have selected. **WARNING:** The recommended weight setting may be too high or too low for you, depending upon such factors as your body size and physical condition. If you cannot complete the desired numbers of sets and repetitions, the weight setting should be decreased. The weight setting can be changed by pressing the increase or decrease button beneath the WEIGHT display. Each time one of the buttons is pressed, the weight setting will change by 1 pound. The buttons can be held down to change the weight setting quickly. (The weight range for the BENCH PRESS exercise is 30 to 250 pounds; the weight range for all other exercises is 15 to 125 pounds.)

IMPORTANT: While the weight setting is changing, the motor will be heard and the SETS and REPS displays will show a rapidly rotating indicator. To prevent damage to the weight system, do not put any pressure on the leg developer, arms or cables while the weight setting is changing. If the lat bar or rower bar is attached to the high pulley station, rest it in the rack near the high pulley station. If the computer senses pressure on the weight system while the weight setting is changing, the WEIGHT display will show an error code ("EEE") for two seconds, and the weight setting will stop changing. The WEIGHT display will then show the current weight setting. Make sure that there is no pressure on the leg developer, arms or cables. Press the increase or decrease button beneath the WEIGHT display again to change the weight setting as desired. Wait for the sound of the motor to stop before you continue.

The SETS and REPS displays will show the recommended numbers of sets and repetitions for the exercise that you have selected. If desired, the number of sets or repetitions can be changed by pressing the increase or decrease button beneath the SETS or REPS display. Each time one of the buttons is pressed, the number of sets or repetitions will change by 1. The range of sets is 1 to 9. The range of repetitions is 2 to 20.

Begin the exercise that you have selected. (Refer to pages 17 through 24 of this owner's manual for information about the proper form for the exercise.) During your first repetition, the computer will measure your range of motion—try to move through the full range of motion for the exercise. During each following repetition, the STROKE meter will show your range of motion—try to reach 100% during each repetition. As you exercise, the SETS and REPS displays will show the numbers of sets and repetitions remaining to be completed. One tone will sound after each repetition is completed, two tones will sound after each set is completed, and three tones will sound after all repetitions and sets have been completed. In addition, the CALORIES indicator will light, and the CALORIES/EXERCISE NO. display will show the number of Calories that you have burned.

IMPORTANT: For effective exercise, rest for 1 minute between sets if you are doing a tone workout, and 3 minutes between sets if you are doing a strength workout. Your body will burn Calories at all times—at a decreased rate while you are resting, and at an increased rate while you are performing repetitions. As soon as the power is turned on, the computer will begin counting the Calories you are burning while you are resting, and will continue to count the Calories you burn until the power is turned off. In order to find the number of Calories you burn during your workout, note the number that is shown as soon as you complete your last exercise.

When all repetitions and sets have been completed for the first exercise that you selected, press the right or left arrow on the NEXT button to select the next exercise that you want to do. Repeat the procedure described above for the next exercise. (Note: If you select an exercise that involves only one arm or leg, such as the SINGLE LEG CURL exercise, the numbers of repetitions and sets shown in the SETS and REPS displays should be performed once using the right arm or leg, and once using the left arm or leg. After completing the repetitions and sets using one arm or leg, press the right arrow on the NEXT button, then press the left arrow on the NEXT button, and then repeat the repetitions and sets using the other arm or leg.) Select as many exercises as desired until your workout is completed.

USING THE TRAINER MODE

Press the TRAINER button. The trainer indicator will light. Next, refer to the muscle chart on the upper part of the computer. An indicator will be lighted on muscle group "A." If you want to exercise a different muscle group first, press on the desired muscle group—be sure to press on the circled letter.

Once you have selected the first muscle group that you want to exercise, refer to the lower part of the computer. One or more indicators will be lighted, showing you which exercise(s) to do to develop the selected muscle group. One of the indicators will be flashing to show you which exercise to do first. If you want to skip the first exercise, press the right arrow on the NEXT button until the indicator is flashing on the exercise that you want to do first. The number of the exercise will be shown in the CALORIES/EXERCISE NO. display.

The WEIGHT display will show the recommended weight setting for the first exercise. If desired, the weight setting can be changed. This can be done in the same manner as when the computer is in the manual mode. The SETS and REPS displays will show the recommended numbers of sets and repetitions for the first exercise. If desired, the number of sets or repetitions can be changed. This can be done in the same manner as when the computer is in the manual mode. Begin the first exercise. (Refer to pages 17 through 24 of this owner's manual for information about the proper form for the exercise.) As you exercise, the computer will provide the same feedback as when it is in the manual mode. When all repetitions and sets have been completed for the first exercise, press the right arrow on the NEXT button to select the next exercise that you want to do. Do as many of the indicated exercises as desired.

When you have completed the desired exercises for the first muscle group that you selected, press on the next muscle group that you want to exercise. Do as many of the indicated exercises as desired. Select as many muscle groups as desired until your workout is completed.

USING THE PROGRAM MODE

Press the POWER button to turn off the power. **IMPORTANT:** Always turn off the power before inserting or removing the SMART CARDS. Carefully insert the CUSTOM SMART CARD into the left side of the computer. Press the POWER button to turn on the power.

The first step in creating an exercise program is to select the exercises that you want to include in your first workout. To do this, the exercise insert and the exercise decal sheet are needed.

Lay the exercise insert down so the spaces numbered 1 through 20 are on top. Next, refer to pages 17 through 24 of this owner's manual and select about 6 to 10 exercises that you want to include in your workout. For each exercise that you select, apply a decal to one of the first 6 to 10 spaces on the insert. If there is a printed decal for the exercise, apply the printed decal. If there is not a printed decal, apply a blank decal and write the name of the exercise on the decal. (Note: Whenever the BENCH PRESS exercise is included in a workout, the decal for the exercise must be applied to the space numbered 1, 11, 21 or 31 on the insert. If the BENCH PRESS exercise is not included, those spaces must be left empty.) Next, label all of the decals on the insert with a designation such as "DAY 1." A sample workout is shown at the right.

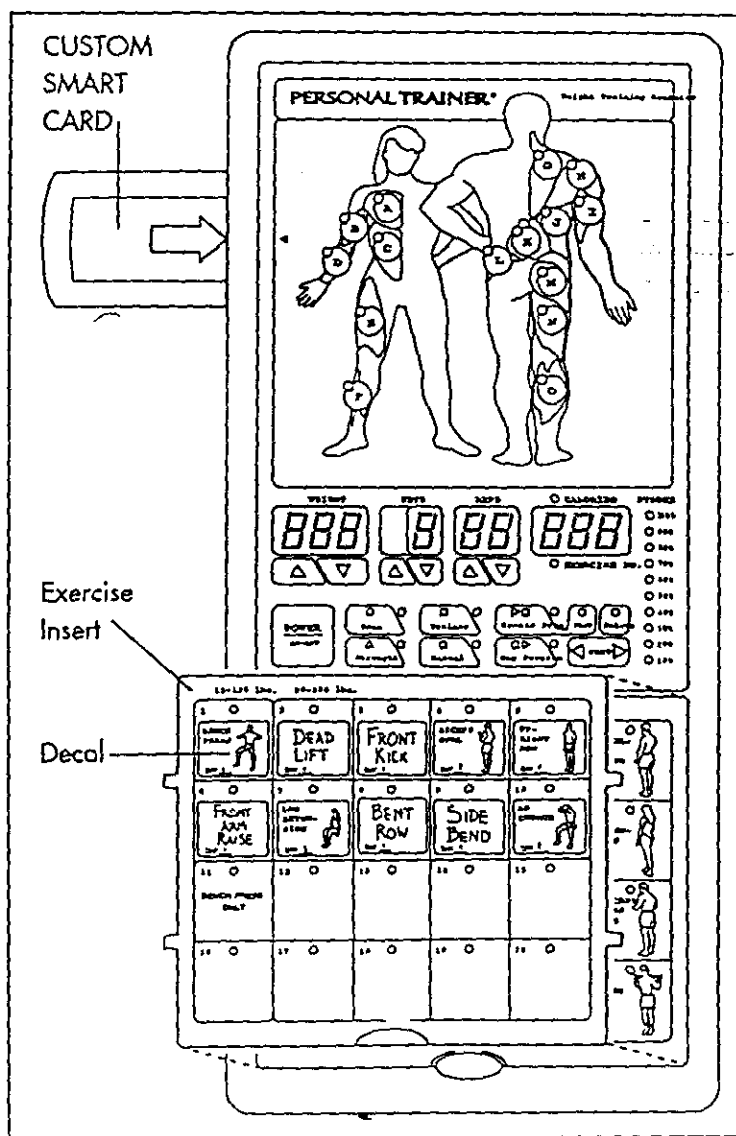

After you have applied a decal to the exercise insert for each of the exercises that you want to include in your first workout, fit the four tabs on the insert into the slots in the lower part of the computer. Make sure that the insert is turned so the spaces on the insert numbered 1 through 20 are visible. (The use of the remaining spaces on the insert will be explained later.)

The next step in creating a workout program is to program a weight, set and resistance setting for each exercise on the exercise insert, and to store the workout on the CUSTOM SMART CARD. Press the CREATE PROGRAM button. The indicator next to the button will light. Press the right or left arrow on the NEXT button, if necessary, until the indicator is flashing on the first exercise on the insert. The number of the exercise will be shown in the CALORIES/EXERCISE NO. display. Program the desired weight setting for the first exercise by pressing the increase or decrease button beneath the WEIGHT display. Each time one of the buttons is pressed, the weight setting will change by 1 pound. The buttons can be held down to program a weight setting quickly. Next, press the increase or decrease buttons beneath the SETS and REPS displays to program the desired numbers of sets and repetitions for the first exercise. Each time one of the buttons is pressed, the number of sets or repetitions will change by 1. When you have programmed the desired weight, set and repetition settings, press the STORE button. The indicator will remain lighted on the first exercise on the insert, and the indicator will begin flashing on the next exercise on the insert. Program weight, set and repetition settings for the next exercise as described above. Press the STORE button. Repeat the procedure described above for each of the exercises on the insert. The workout will then be stored on the CUSTOM SMART CARD.

When you are ready to do the workout, press the RUN PROGRAM button. The indicator next to the button will light. The indicators will light on all of the exercises on the exercise insert, and the indicator on the first exercise will begin flashing. Begin the first exercise. (Refer to pages 17 through 24 of this owner's manual for information about the proper form for the exercise.) As you exercise, the computer will provide the same feedback as when it is in the manual mode.

When all repetitions and sets have been completed for the first exercise, press the right arrow on the NEXT button until the indicator is flashing on the next exercise on the exercise insert. Perform the next exercise as described above. Continue in this manner until all of the exercises included in the workout have been completed.

The workout can be revised as your fitness level increases or your goals change. To revise the workout, first press the CREATE PROGRAM button. To revise the settings for an exercise, press the right or left arrow on the NEXT button until the indicator is flashing on the exercise that you want to revise. Press the increase or decrease button below the WEIGHT, SETS or REPS display to change the setting. Press the STORE button. To delete an exercise, press the right or left arrow on the NEXT button until the indicator is flashing on the exercise that you want to delete. Press the DELETE button. Remove the decal for the exercise from the exercise insert. To add an exercise, attach a decal to the insert and press the right or left arrow on the NEXT button until the indicator is flashing on the new exercise on the insert. Program weight, set and repetition settings as described above. Press the STORE button.

Because there are 40 spaces on the exercise insert, a number of different workouts can be stored on the CUSTOM SMART CARD at the same time. For example, your exercise program could include three different workouts—one for Mondays, one for Wednesdays, and one for Fridays. Or, you could create two different workouts using the spaces numbered 1 through 20 on the insert, and a training partner could create two different workouts using the spaces numbered 21 through 40. To do one of the workouts, first press the RUN PROGRAM button. Press the right or left arrow on the NEXT button until the indicator is flashing on the first exercise of the workout that you want to do. Then, complete the workout as described above. The CUSTOM SMART CARD can be programmed in a variety of ways to fit your individual needs.

TURNING OFF THE POWER

To turn off the power, press the POWER button. Note: If no buttons on the computer are pressed for 30 minutes, the power will turn off automatically. The transformer should be unplugged from the 120-volt outlet during periods of nonuse.

EXERCISE GUIDE

SAFETY

The CROSS TRAINER e is a tool, and learning to use it properly is essential for your safety as well as the success of your exercise program. Read this owner's manual and the accompanying FITNESS JOURNAL carefully before using the CROSS TRAINER e. Remember, the information in this owner's manual and in the FITNESS JOURNAL is general in nature. For more information about exercise, consult your physician or obtain a reputable book about exercise.

WARNING: Before beginning any exercise program, consult your physician. This is especially important for persons over the age of 35 or persons with pre-existing health problems.

THE FOUR BASIC TYPES OF EXERCISE PROGRAMS

STRENGTH

In order to increase the size and strength of your muscles, you must subject your muscles to above-normal workloads. You must also progressively increase the intensity of your exercise so that your muscles will continue to adapt and grow. Each individual exercise can be tailored to the proper intensity level by changing the weight setting, or the number of repetitions or sets completed. The proper weight setting and numbers of sets and repetitions for each exercise depends upon the individual user.

Each workout should include about 6 to 10 different exercises. Select exercises for every major muscle group, with emphasis on the areas that you want to develop the most. To give balance and variety to your workouts, vary the exercises from workout to workout.

TONING

To tone your muscles, select moderate weight settings and increase the number of repetitions in each set. Work your muscles by completing more repetitions rather than by using high weight settings.

LOSING WEIGHT

To lose weight, select low weight settings and increase the number of repetitions in each set. Exercising on the stepper will also help you to burn Calories and shed extra pounds.

CROSS TRAINING

In the pursuit of a complete and well-balanced fitness program, many have found that cross training is the answer. The CROSS TRAINER e is ideal for cross training. By combining weight training with aerobic exercise, you can reshape and strengthen your body, plus develop a stronger heart and lungs.

EXERCISE FORM

In order to obtain the greatest benefits from exercising, it is essential to maintain proper form. Maintaining proper form means moving through the full range of motion for each exercise, and moving only the appropriate parts of the body. On pages 17 through 24 of this owner's manual, you will find photographs showing the correct form for each exercise. A description of each exercise is also provided, along with a list of the muscles affected. Refer to the muscle chart in the accompanying FITNESS JOURNAL to find the locations of the muscles. As you exercise, the repetitions in each set should be performed smoothly and without pausing. The exertion phase of each repetition should last only about half as long as the return phase. Rest for 1 minute between sets if you are doing a tone workout, and 3 minutes between sets if you are doing a strength workout. Plan to spend the first two weeks learning the proper form for each exercise.



1. BUTTERFLY (15-125 Lbs.)

Muscles affected: pectoralis major and minor, deltoids

Refer to adjustment 2 on page 8 of this owner's manual. Change the arms to the butterfly mode. Sit on the seat and hold the pads on the arms as shown; your arms should be bent at 90° angles. Keep your back straight. Press the arms together until the pads touch. Return to the starting position.



2. BENCH PRESS (30-250 Lbs.)

Muscles affected: pectoralis major and minor, anterior deltoids, triceps

Refer to adjustment 2 on page 8 of this owner's manual. Change the arms to the press mode. Sit on the seat and hold the handles on the arms with an overhand grip. Raise your elbows as shown. Keep your back straight. Fully extend your arms. Return to the starting position.



3. FRONT ARM RAISE (15-125 Lbs.)

Muscles affected: deltoids, rhomboids

Refer to adjustment 4 on page 9 of this owner's manual. Attach the strap to the low pulley station. Stand with one heel on the foot plate. Hold the strap with an overhand grip with your arm at your side. Keep your back straight. Raise the strap until your hand is level with your shoulder as shown. Return to the starting position.



4. UPRIGHT ROW (15-125 Lbs.)

Muscles affected: biceps, deltoids, trapezius

Refer to adjustment 4 on page 9 of this owner's manual. Attach the rower bar to the low pulley station. Stand with your feet on the foot plate. Hold the rower bar with an overhand grip with your arms extended downward. Keep your back straight. Lift the rower bar until your hands are level with your chest as shown. Return to the starting position.



5. SHOULDER SHRUG (15-125 Lbs.)

Muscles affected: trapezius, rhomboids

Refer to adjustment 4 on page 9 of this owner's manual. Attach the rower bar to the low pulley station. Stand with your feet on the foot plate. Hold the rower bar with an overhand grip with your arms extended downward. Keep your back straight and your arms at your sides. Shrug your shoulders up as far as possible. Return to the starting position.



6. LATERAL ARM RAISE (15–125 Lbs.)

Muscles affected: deltoids, trapezius

Refer to adjustment 4 on page 9 of this owner's manual. Attach the strap to the low pulley station. Stand with your side toward the CROSS TRAINER e with your feet on the foot plate. Hold the strap with an overhand grip with your arm at your side. Keep your back straight. Raise the strap to the side until your hand is level with your shoulder as shown. Return to the starting position.

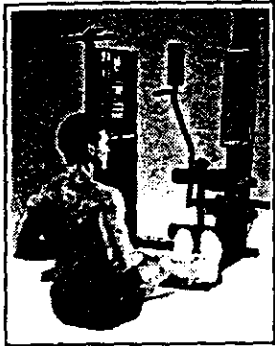

7. SEATED ROW—CLOSE GRIP (15–125 Lbs.)

Muscles affected: deltoids, trapezius, biceps, brachioradials, latissimus dorsi

Refer to adjustment 4 on page 9 of this owner's manual. Attach the rower bar to the low pulley station. Sit on the floor with your heels on the foot plate. Lean forward, extend your arms and hold the rower bar with an overhand grip. Pull the rower bar toward your stomach and lean back, keeping your elbows close to your sides. Return to the starting position.



8. LAT PULL-DOWN—CHEST (15–125 Lbs.)

Muscles affected: latissimus dorsi, trapezius, pectoralis major

Refer to adjustment 3 on page 8 of this owner's manual. Attach the lat bar to the high pulley station. Sit on the seat facing the CROSS TRAINER e. Extend your arms upward and hold the lat bar with an overhand grip. Keep your back straight. Pull the lat bar down until your hands are level with your neck as shown. Return to the starting position.



9. LAT PULL-DOWN—BACK (15–125 Lbs.)

Muscles affected: latissimus dorsi, trapezius

Refer to adjustment 3 on page 8 of this owner's manual. Attach the lat bar to the high pulley station. Sit on the seat facing the CROSS TRAINER e. Extend your arms upward and hold the lat bar with an overhand grip. Keep your back straight and lean forward slightly. Pull the lat bar down behind your head until your hands are level with your neck. Return to the starting position.



10. HIP EXTENSION (15–125 Lbs.)

Muscles affected: gluteus maximus

Refer to adjustment 4 on page 9 of this owner's manual. Attach the strap to the low pulley station. Stand with one foot on the foot plate. Insert one leg into the strap. Keep your back straight. Keep your leg straight and move it backward as far as possible. Return to the starting position.



11. LEG EXTENSION (15-125 Lbs.)

Muscles affected: quadriceps

Sit on the seat and position your feet under the pads on the leg developer. Keep your back straight. Raise the leg developer until your legs are straight. Return to the starting position.



12. HIP ABDUCTION (15-125 Lbs.)

Muscles affected: abductor, gluteus medius

Refer to adjustment 4 on page 9 of this owner's manual. Attach the strap to the low pulley station. Stand with your side toward the CROSS TRAINER e with one foot on the foot plate. Insert your outside leg into the strap. Keep your back straight. Keep your leg straight and move it to the side as far as possible. Return to the starting position.



13. BICEPS CURL (15-125 Lbs.)

Muscles affected: biceps, brachioradials

Refer to adjustment 4 on page 9 of this owner's manual. Attach the rower bar to the low pulley station. Stand with your feet on the foot plate. Hold the rower bar with an underhand grip with your arms extended downward. Keep your back straight and your elbows close to your sides. Curl the rower bar up toward your chest as shown. Return to the starting position.



14. TRICEPS EXTENSION (15-125 Lbs.)

Muscles affected: triceps, brachioradials

Refer to adjustment 3 on page 8 of this owner's manual. Attach the rower bar to the high pulley station. Sit on the seat, hold the rower bar above your head and bend your elbows. Keep your back straight and your elbows in. Slowly straighten your arms as shown. Return to the starting position.



15. TRICEPS PRESS-DOWN (15-125 Lbs.)

Muscles affected: triceps, brachioradials

Refer to adjustment 3 on page 8 of this owner's manual. Attach the rower bar to the high pulley station. Stand with your feet on the foot plate. Hold the rower bar with an overhand grip with your hands at chest level. Keep your back straight and your elbows close to your sides. Press the rower bar down until your arms are straight. Return to the starting position.



16. SINGLE LEG CURL (15-125 Lbs.)

Muscles affected: hamstring, gastrocnemius

Stand facing the CROSS TRAINER and rest the back of one leg against the lower pad on the leg developer. Raise the leg developer as far as possible by bending your leg as shown. Return to the starting position.



17. AB CRUNCH (15-125 Lbs.)

Muscles affected: rectus abdominus, upper abdominals

Refer to adjustment 3 on page 8 of this owner's manual. Attach the strap to the high pulley station. Sit on the seat and hold the strap behind your head as shown. Keep your back straight. Slowly bend forward at the waist until your upper body is at a 45° angle. Return to the starting position.

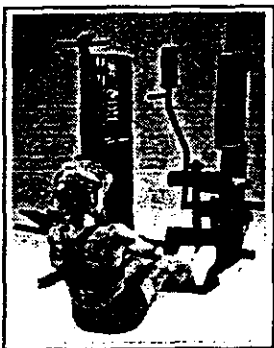

18. BACK EXTENSION (15-125 Lbs.)

Muscles affected: hip extensors

Refer to adjustment 4 on page 9 of this owner's manual. Attach the lat bar to the low pulley station. Sit on the floor with your heels on the foot plate. Cross your arms and hold the lat bar against your chest as shown. Keep your back straight. Bend back at the waist. Return to the starting position.



19. WRIST CURL (15-125 Lbs.)

Muscles affected: brachioradials

Refer to adjustment 4 on page 9 of this owner's manual. Attach the rower bar to the low pulley station. Stand with your feet on the foot plate. Hold the rower bar with an overhand grip with your arms extended downward. Keep your arms stationary and curl your hands up as far as possible. Return to the starting position.



20. TOE RAISE (15-125 Lbs.)

Muscles affected: gastrocnemius

Refer to adjustment 4 on page 9 of this owner's manual. Attach the rower bar to the low pulley station. Stand with your feet on the foot plate. Hold the rower bar with an overhand grip with your arms extended downward. Keep your back straight and your arms at your sides. Rise up on your toes as far as possible. Return to the starting position.



A. SIDE BEND (15-125 Lbs.)

Muscles affected: latissimus dorsi, biceps, posterior deltoids

Refer to adjustment 4 on page 9 of this owner's manual. Attach the strap to the low pulley station. Stand with your side toward the CROSS TRAINER e with one foot on the foot plate. Hold the strap with an overhand grip with your arm at your side. Keep your back straight. Bend toward the side as shown. Return to the starting position.



B. LAT PULL-DOWN—CLOSE GRIP (15-125 Lbs.)

Muscles affected: latissimus dorsi, biceps, posterior deltoids

Refer to adjustment 3 on page 8 of this owner's manual. Attach the rower bar to the high pulley station. Sit on the seat facing the CROSS TRAINER e. Extend your arms upward and hold the rower bar with an underhand grip. Keep your back straight. Pull the rower bar down until your hands are level with your neck. Return to the starting position.

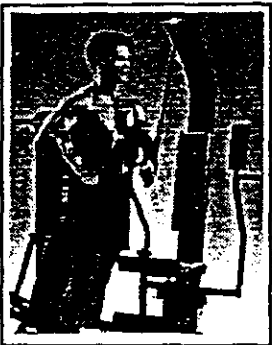

C. SINGLE ARM CABLE FLY (15-125 Lbs.)

Muscles affected: latissimus dorsi, biceps, posterior deltoids

Refer to adjustment 3 on page 8 of this owner's manual. Attach the strap to the high pulley station. Stand with your side toward the CROSS TRAINER e with one foot on the foot plate. Extend one arm upward and hold the strap. Keep your back straight. Pull the strap down until your hand is level with your waist. Return to the starting position.



D. BENT ROW—WIDE GRIP (15-125 Lbs.)

Muscles affected: biceps, brachioradials, deltoids, trapezius, latissimus dorsi, rhomboids

Refer to adjustment 4 on page 9 of this owner's manual. Attach the lat bar to the low pulley station. Stand with your feet on the foot plate and bend forward as shown. Hold the lat bar with an overhand grip with your arms extended downward. Keep your back straight. Pull the lat bar toward your stomach. Return to the starting position.



E. BENT ROW—CLOSE GRIP (15-125 Lbs.)

Muscles affected: biceps, brachioradials, deltoids, trapezius, latissimus dorsi, rhomboids

Refer to adjustment 4 on page 9 of this owner's manual. Attach the rower bar to the low pulley station. Stand with your feet on the foot plate and bend forward as shown. Hold the rower bar with an overhand grip with your arms extended downward. Keep your back straight. Pull the rower bar toward your stomach. Return to the starting position.



F. SINGLE ARM BENT ROW (15–125 Lbs.)

Muscles affected: biceps, brachioradials, deltoids, trapezius, latissimus dorsi, rhomboids

Refer to adjustment 4 on page 9 of this owner's manual. Attach the strap to the low pulley station. Stand with your feet on the foot plate and bend forward as shown. Hold the strap with an overhand grip with your arm extended downward. Keep your back straight. Pull the strap toward your stomach. Return to the starting position.



G. SEATED ROW—WIDE GRIP (15–125 Lbs.)

Muscles affected: deltoids, trapezius, biceps, brachioradials, latissimus dorsi

Refer to adjustment 4 on page 9 of this owner's manual. Attach the lat bar to the low pulley station. Sit on the floor with your heels on the foot plate. Lean forward, extend your arms and hold the lat bar with an overhand grip. Pull the lat bar toward your stomach and lean back. Return to the starting position.



H. SINGLE ARM SEATED ROW (15–125 Lbs.)

Muscles affected: biceps, brachioradials, deltoids, trapezius, latissimus dorsi, rhomboids

Refer to adjustment 4 on page 9 of this owner's manual. Attach the strap to the low pulley station. Sit on the floor with your heels on the foot plate. Lean forward, extend one arm and hold the strap. Pull the strap toward your stomach and lean back, keeping your elbow close to your side. Return to the starting position.



I. REVERSE BICEPS CURL (15–125 Lbs.)

Muscles affected: biceps, brachioradials

Refer to adjustment 4 on page 9 of this owner's manual. Attach the rower bar to the low pulley station. Stand with your heel on the foot plate. Hold the rower bar with an overhand grip with your arms extended downward. Keep your back straight and your elbows close to your sides. Curl the rower bar up toward your chest as shown. Return to the starting position.

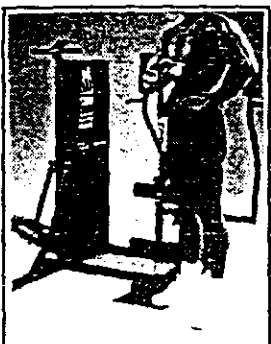

J. ISOLATION CURL (15–125 Lbs.)

Muscles affected: biceps, brachioradials

Refer to adjustment 4 on page 9 of this owner's manual. Attach the strap to the low pulley station. Stand with your side toward the CROSS TRAINER with one foot on the foot plate. Hold the strap with an underhand grip with your arm extended downward. Pull the strap up until your hand is level with your chest. Return to the starting position.



K. BENT ISOLATION CURL (15–125 Lbs.)

Muscles affected: biceps, brachioradials

Refer to adjustment 4 on page 9 of this owner's manual. Attach the strap to the low pulley station. Stand with your side toward the CROSS TRAINER e, place one foot on the foot plate and bend forward as shown. Hold the strap with an underhand grip with your elbow resting against your knee and your arm extended downward. Pull the strap up until your hand is level with your chest. Return to the starting position.



L. REVERSE WRIST CURL (15–125 Lbs.)

Muscles affected: brachioradials

Refer to adjustment 4 on page 9 of this owner's manual. Attach the rower bar to the low pulley station. Stand facing away from the CROSS TRAINER e with your heels on the foot plate. Hold the rower bar behind your back as shown. Keep your arms stationary and curl your hands up as far as possible. Return to the starting position.



M. REVERSE TRICEPS PRESS-DOWN (15–125 Lbs.)

Muscles affected: triceps, brachioradials

Refer to adjustment 3 on page 8 of this owner's manual. Attach the rower bar to the high pulley station. Stand with your feet on the foot plate. Hold the rower bar with an underhand grip with your hands at chest level. Keep your back straight and your elbows close to your sides. Press the rower bar down until your arms are straight. Return to the starting position.



N. SINGLE ARM TRICEPS PRESS-DOWN (15–125 Lbs.)

Muscles affected: triceps, brachioradials

Refer to adjustment 3 on page 8 of this owner's manual. Attach the strap to the high pulley station. Stand with your feet on the foot plate. Hold the strap with an overhand grip with your hand at chest level. Keep your back straight and your elbow close to your side. Press the strap down until your arm is straight as shown. Return to the starting position.



O. REVERSE UPRIGHT ROW (15–125 Lbs.)

Muscles affected: biceps, deltoids, trapezius

Refer to adjustment 4 on page 9 of this owner's manual. Attach the rower bar to the low pulley station. Stand facing away from the CROSS TRAINER e with your heels on the foot plate. Hold the rower bar behind your back with your arms extended downward. Lift the rower bar up as far as possible. Return to the starting position.



P. BENT LATERAL ARM RAISE (15-125 Lbs.)

Muscles affected: deltoids, trapezius

Refer to adjustment 4 on page 9 of this owner's manual. Attach the strap to the low pulley station. Stand with your side toward the CROSS TRAINER e, place one foot on the foot plate and bend forward as shown. Hold the strap with an overhand grip with your arm at your side. Keep your back straight. Raise the strap to the side until your hand is level with your shoulder. Return to the starting position.



Q. DEAD LIFT (15-125 Lbs.)

Muscles affected: quadriceps

Refer to adjustment 4 on page 9 of this owner's manual. Attach the lat bar to the low pulley station. Stand with your feet on the foot plate and bend your knees as shown. Hold the lat bar with an overhand grip. Keep your head up and your arms and back straight. Lift the lat bar by straightening your legs. Return to the starting position.



R. HIP ADDUCTION (15-125 Lbs.)

Muscles affected: adductor, gluteus medius

Refer to adjustment 4 on page 9 of this owner's manual. Attach the strap to the low pulley station. Stand with your side toward the CROSS TRAINER e with one foot on the foot plate. Insert your inside leg into the strap. Keep your back straight. Keep your leg straight and move it to the side as far as possible. Return to the starting position.



S. FRONT KICK (15-125 Lbs.)

Muscles affected: hip flexors, sartorius

Refer to adjustment 4 on page 9 of this owner's manual. Attach the strap to the low pulley station. Stand facing away from the CROSS TRAINER e with one heel on the foot plate. Insert one leg into the strap. Keep your leg straight and move it away from the CROSS TRAINER e as far as possible. Return to the starting position.



STEPPER

Muscles Affected: quadriceps, hip extensors

(Note: Do not include this exercise in workouts created with the PERSONAL TRAINER computer. When the STEPPER is used, the stepper console will provide feedback.) Refer to adjustment 1 on page 8 of this owner's manual. Hold the stepper handle and begin stepping, alternately pressing the left and right pedals down with a smooth, continuous motion—continuous motion must be maintained or both pedals will sink to the floor. Adjust the stepping resistance if necessary.

ORDERING REPLACEMENT PARTS

Each CROSS TRAINER e has its own MODEL NUMBER. Always mention this MODEL NUMBER when requesting service or repair parts for your CROSS TRAINER e.

All parts listed herein can be ordered through SEARS, ROEBUCK AND CO. SERVICE CENTERS and most SEARS RETAIL STORES. If parts you need are not stocked locally, your order will be transmitted to a SEARS PARTS DISTRIBUTION CENTER for handling.

WHEN ORDERING REPAIR PARTS, ALWAYS GIVE THE FOLLOWING INFORMATION:

1. The MODEL NUMBER of the product (831.159341).
2. The NAME of the product (PROFORM® CROSS TRAINER e).
3. The PART NUMBER of the part(s) from the PART LIST/EXPLODED DRAWING accompanying this owner's manual.
4. The DESCRIPTION of the part(s) from the PART LIST/EXPLODED DRAWING accompanying this owner's manual.

Your SEARS merchandise has added value when you consider that SEARS has service units nationwide, staffed with SEARS trained technicians specifically trained on SEARS products, having the parts, tools and equipment to ensure that we meet our pledge to you: "We service what we sell."

Should you ever need repair service or parts, call toll-free:

For repair service: 1-800-4-REPAIR (1-800-473-7247)

For repair parts: 1-800-FON-PART (1-800-366-7278)

FULL 90 DAY WARRANTY

For 90 days from the date of purchase, when proper assembly and maintenance procedures detailed in the owner's manual are followed, SEARS will, free of charge, repair or replace and install a replacement part for any defective part, when the PROFORM® CROSS TRAINER e is used in a normal manner.

This warranty does not apply when the CROSS TRAINER e is used for commercial or rental purposes.

SERVICE IS AVAILABLE SIMPLY BY CONTACTING YOUR NEAREST SEARS SERVICE CENTER/DEPARTMENT IN THE UNITED STATES.

This warranty gives you specific legal rights; you may also have other rights which vary from state to state.

SEARS, ROEBUCK AND CO., DEPT. 817WA,
3333 BEVERLY ROAD, HOFFMAN ESTATES, IL 60179