

PRO-FORM

Air Walker™

NO IMPACT TOTAL BODY WORKOUT

SEARS

Model No. 831.290820

Serial No. _____

Write the serial number in the space above for future reference.

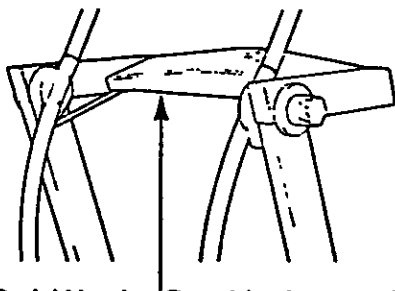

Serial Number Decal (under console)

**EXERCISE
EQUIPMENT**

QUESTIONS

HELPLINE!

Patent Pending

CAUTION

Read all precautions and instructions in this manual before using this equipment. Keep this manual for future reference.

USER'S MANUAL

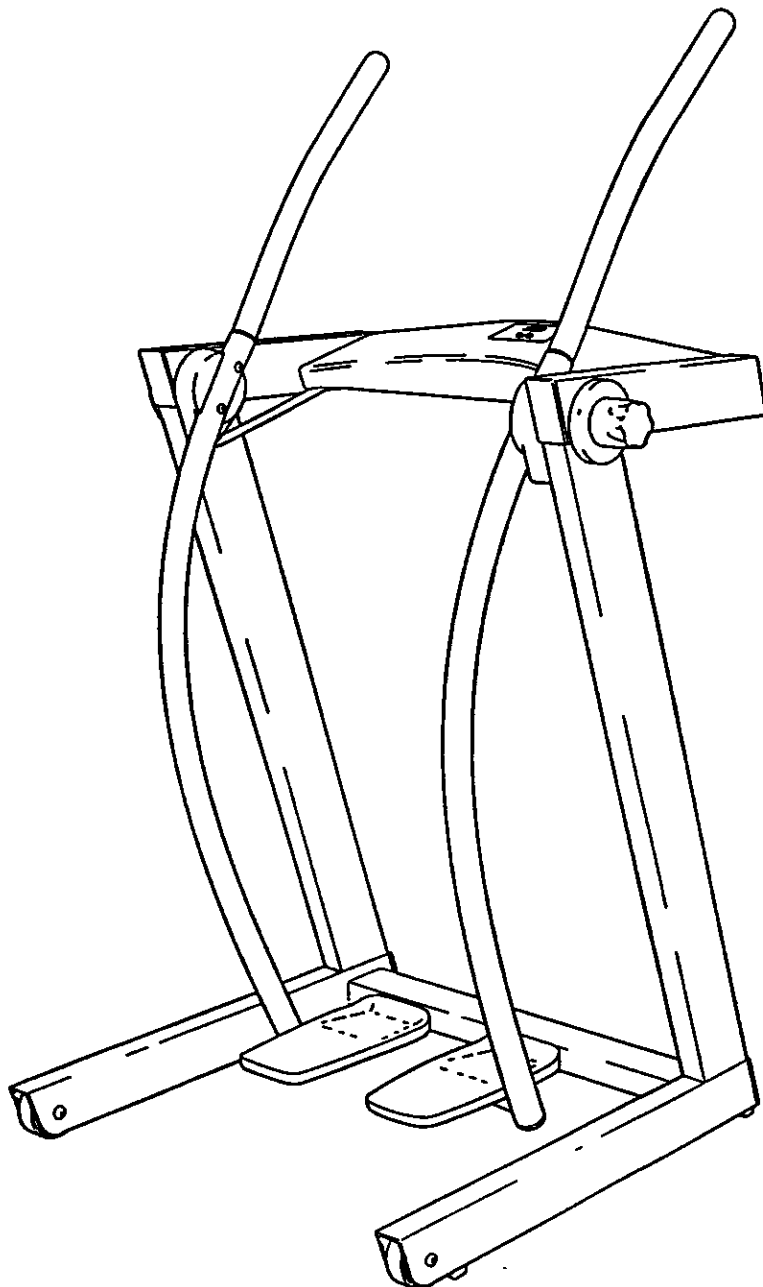

SEARS, ROEBUCK AND CO., HOFFMAN ESTATES, IL 60179

TABLE OF CONTENTS

IMPORTANT PRECAUTIONS	2
BEFORE YOU BEGIN	3
ASSEMBLY	4
OPERATION AND MAINTENANCE	7
CONDITIONING GUIDELINES	9
PART LIST	10
EXPLODED DRAWING	11
ORDERING REPLACEMENT PARTS	Back Cover
FULL 90 DAY WARRANTY	Back Cover

IMPORTANT PRECAUTIONS

WARNING: To reduce the risk of serious injury, read the following important precautions before using the AIR WALKER.

1. It is the responsibility of the owner to ensure that all users of the AIR WALKER are adequately informed of all warnings and precautions.
2. Read all instructions in this manual before using the AIR WALKER.
3. Use the AIR WALKER only on a level surface. Cover the floor beneath the AIR WALKER to protect the floor or carpet.
4. Be sure that there are no obstacles in front of or behind the AIR WALKER.
5. Inspect and tighten all parts regularly. Replace any worn parts immediately.
6. Keep small children and pets away from the AIR WALKER at all times.
7. The AIR WALKER should not be used by persons weighing more than 250 pounds.
8. Keep hands and feet away from moving parts.
9. Do not wear loose clothing that could become caught on the AIR WALKER. Always wear athletic shoes for foot protection when exercising.
10. When you are getting onto and off the AIR WALKER, always tighten the resistance knobs, hold the handles firmly, and be sure that your body weight is centered directly over the pedals.
11. Use the AIR WALKER only as described in this manual.
12. If you feel faint, dizzy, or short of breath while exercising, stop immediately and begin cooling down.
13. The following precautions are printed on the electronic monitor: Read User's Manual before operating; To enter and exit, tighten resistance knobs, grasp handles, and place body directly over foot pedals; Stop if you feel faint, dizzy, or short of breath; Keep children away.

WARNING: Before beginning this or any exercise program, consult your physician. This is especially important for persons over the age of 35 or persons with pre-existing health problems. Read all instructions before using. SEARS assumes no responsibility for personal injury or property damage sustained by or through the use of this product.

BEFORE YOU BEGIN

Thank you for selecting the innovative PROFORM® AIR WALKER. The AIR WALKER blends advanced engineering with contemporary styling to provide you with a no-impact, total body workout in the convenience and privacy of your own home.

For your benefit, read this manual carefully before using the AIR WALKER. If you have additional questions, please call our toll-free HELPLINE at 1-800-736-6879, Monday through Saturday, 7 a.m. until 7 p.m.

Central Time (excluding holidays). To help us assist you, please note the product model number and serial number before calling. The model number is 831.290820. The serial number can be found on a decal attached to the AIR WALKER (see the front cover of this manual for the location of the decal).

Before reading further, please review the drawing below and familiarize yourself with the parts that are labeled.

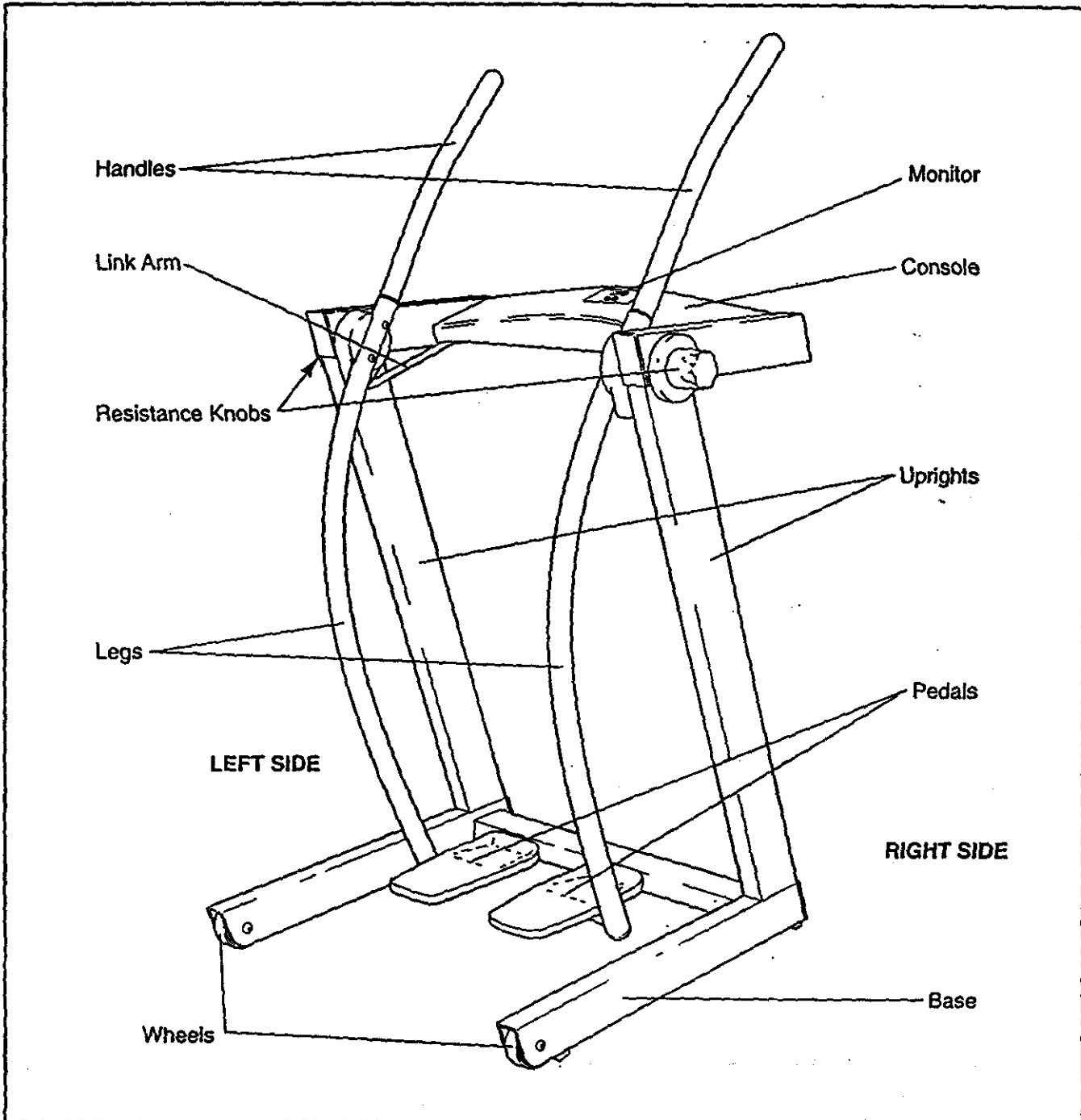

ASSEMBLY

Before you begin assembly, carefully read the following information and instructions:

- Place all parts of the AIR WALKER in a cleared area and remove the packing materials. **IMPORTANT: DO NOT REMOVE THE RUBBER BANDS FROM THE HUB COVERS** (see assembly step 5). Do not dispose of any packing materials until assembly is completed.
- Use the drawings below to identify the small hardware used in assembly.

- Read through each assembly step before you begin.
- Make sure that all parts are oriented as shown in the drawings. Tighten all parts as you assemble them, unless instructed to do otherwise.

Assembly requires the following tools:

- the included allen wrench 
- your own phillips screwdriver 

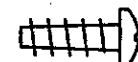
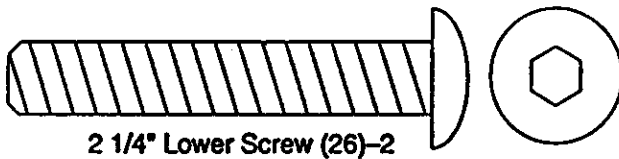
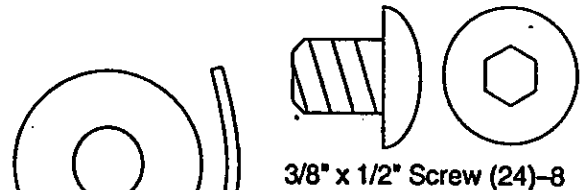
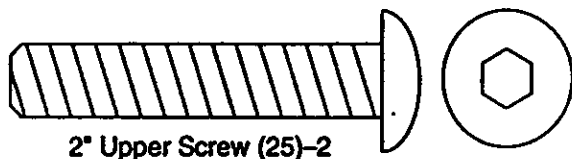

- Before you begin, read the information at the top of this page.

See figure 1. Find the Left Upright (3). Note: There is a "TOP LEFT" sticker on the upper end of the Left Upright for identification. Slide the Left Upright onto the Base (1). Thread two 3/8" x 1/2" Screws (24) into the Left Upright. Note: Do not tighten the Screws yet.

See figure 1. Attach the Right Upright (4) in the same manner.

- See figure 2. Hold the Top Frame (2) level, and insert it into the Left and Right Uprights (3 and 4). Note: It may be helpful to rock the Top Frame from side to side slightly as you insert it. Make sure that the indicated rubber bands are not pinched between the Top Frame and the Uprights. Attach the Top Frame with four 3/8" x 1/2" Screws (24).

See figures 1 and 2. Tighten the eight 3/8" x 1/2" Screws (24).

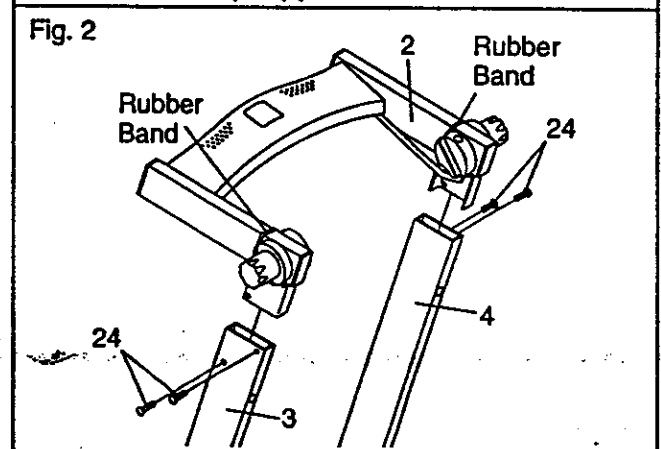
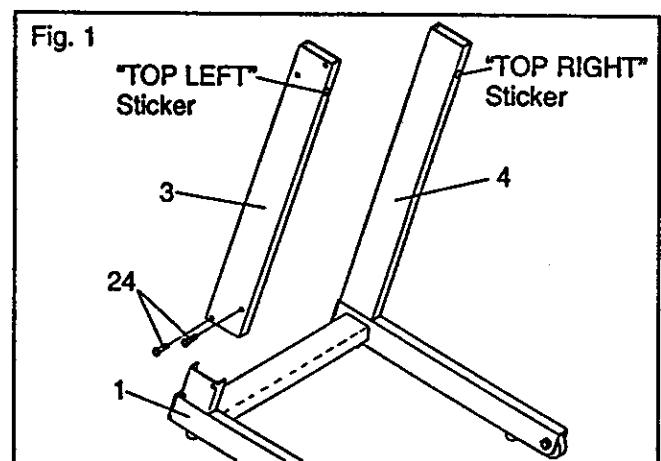

- See figure 3b. Find the Right Leg (7). Note: The Right Leg is marked with a "RIGHT" sticker. Set a Pedal (28) on the plate at the lower end of the Right Leg. Note: Be careful not to attach the Pedal backwards. Look at the curve of the Right Leg and the front end of the Pedal to make sure that the Pedal is turned correctly.

See figure 3a. Turn the Right Leg (7) and the Pedal (28) upside-down as shown. Attach the Pedal with four #8 x 1/2" Screws (31).

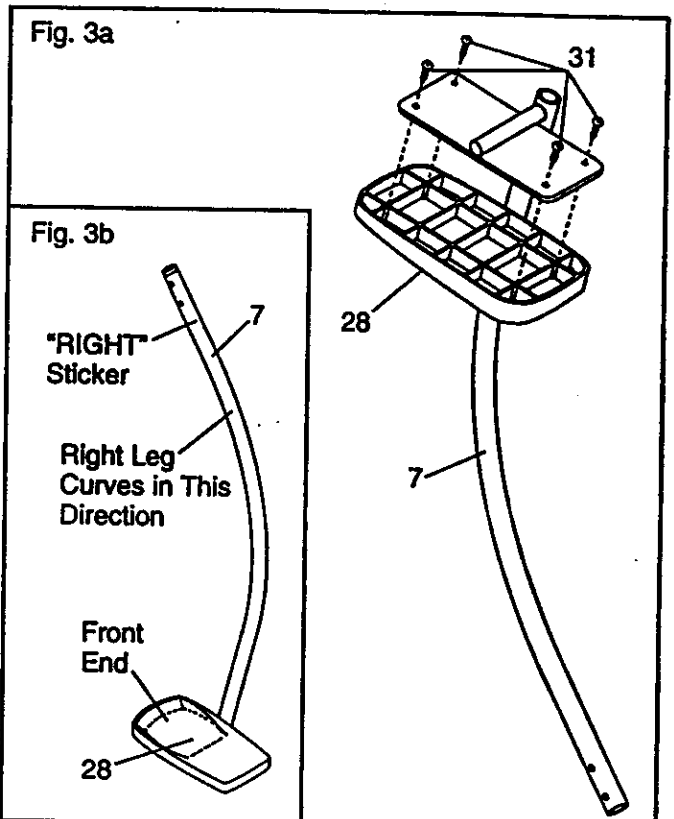

- See figure 4. Look into the upper end of the Right Leg (7) and make sure that the Plastic Sleeve (41) is fully inserted.

See figure 4. Find the Right Handle (11). Note: The Right Handle is marked with a "RIGHT" sticker. Insert the Right Handle into the Right Leg (7).

See figure 4. Slide a 3/8" Curved Washer (27) onto a 2" Upper Screw (25). Note: Use the actual-size drawing to identify the 2" Upper Screw (25). Insert the 2" Upper Screw into the upper hole in the Right Leg (7) and the Right Handle (11).

See figure 4. Slide a 3/8" Curved Washer (27) onto a 2 1/4" Lower Screw (26). Note: Use the actual-size drawing to identify the 2 1/4" Lower Screw (26). Insert the 2 1/4" Lower Screw into the lower hole in the Right Leg (7) and the Right Handle (11).

See figure 4. Make sure that the 2" Upper Screw (25) is in the upper hole, and that the 2 1/4" Lower Screw (26) is in the lower hole. The Screws must be inserted from the side shown.

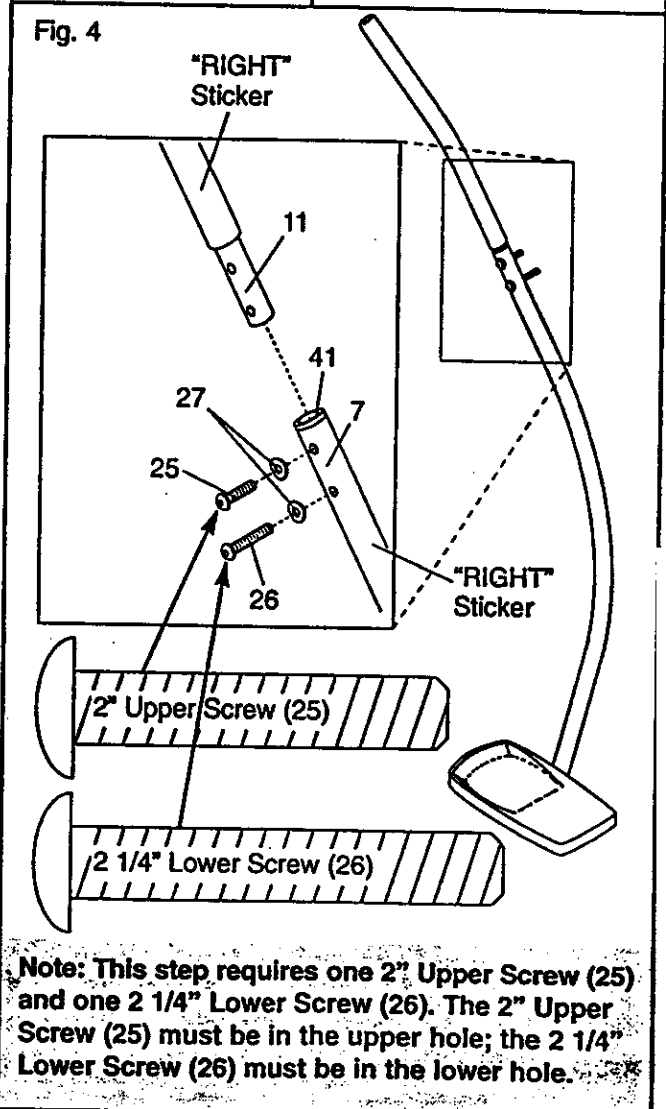

- See figure 5a. Before you begin this step, make sure that the Right Hub Cover (19) is attached to the Top Frame (2) with a rubber band as shown. If the Right Hub Cover has come off during shipping, see figure 5b. Insert the Leg Saddle (55) into the back of the Right Hub Cover (19). (Note: Make sure that the Leg Saddle is turned so the "TOP" sticker is at the top.) Slide the Right Hub Cover onto the Right Pivot Plate (20).

See figure 5a. Find the two holes inside the slot of the Right Hub Cover (19). Make sure that the rubber band is not covering the holes, and that the holes are aligned.

See figure 5a. Hold the Right Leg (7) against the Right Hub Cover (19). Thread the 2" Upper Screw (25) two complete turns into the upper hole inside the Right Hub Cover. Thread the 2 1/4" Lower Screw (26) two complete turns into the lower hole. Break and remove the rubber band.

See figure 5a. Fully tighten the 2" Upper Screw (25). After the 2" Upper Screw is tightened, fully tighten the 2 1/4" Lower Screw (26).

Repeat assembly steps 3, 4, and 5 to attach the Left Leg and the Left Handle (not shown) to the left side of the AIR WALKER.

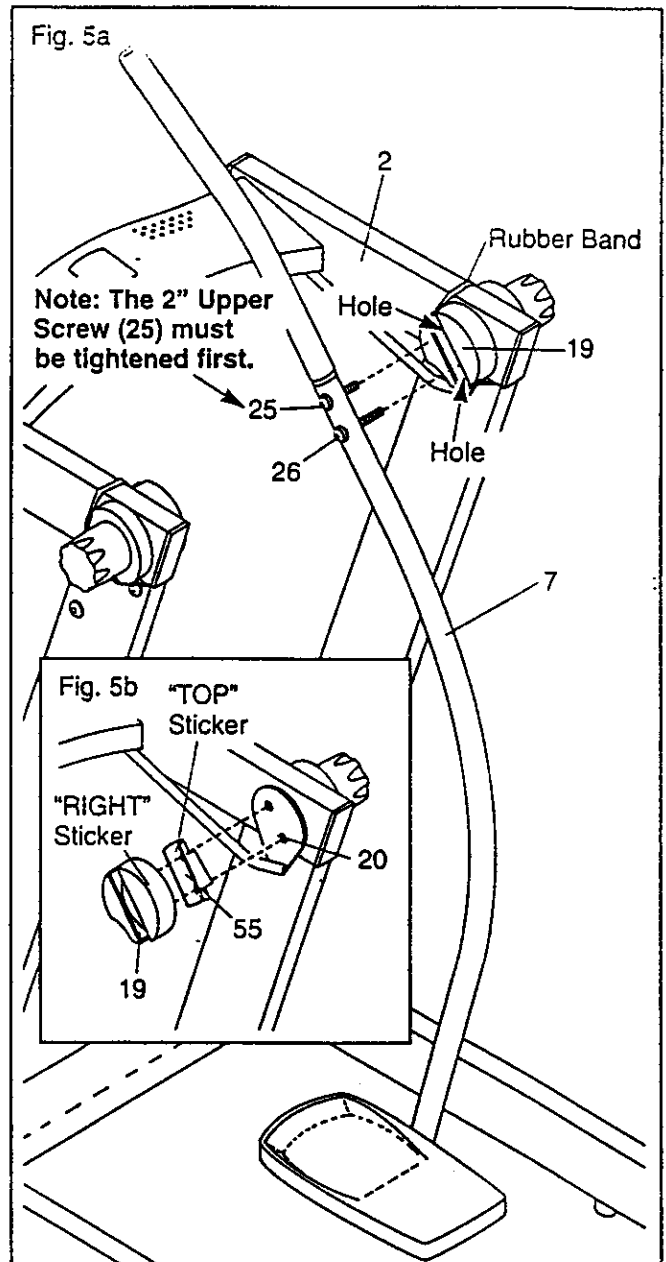

- See figure 6a. Insert two "AA" batteries (not included) into the Monitor (39). Alkaline batteries are recommended. Make sure that the negative (-) ends of the batteries are touching the springs, and that the positive (+) ends of the batteries are pushed against the metal contacts.

See figure 6a. Plug the Reed Switch Wire (44) into the Monitor (39). Insert any excess wire into the Console (40).

See figure 6b. Snap the Monitor (39) into the Console (40). Be careful not to pinch the wire between the Monitor and the Console.

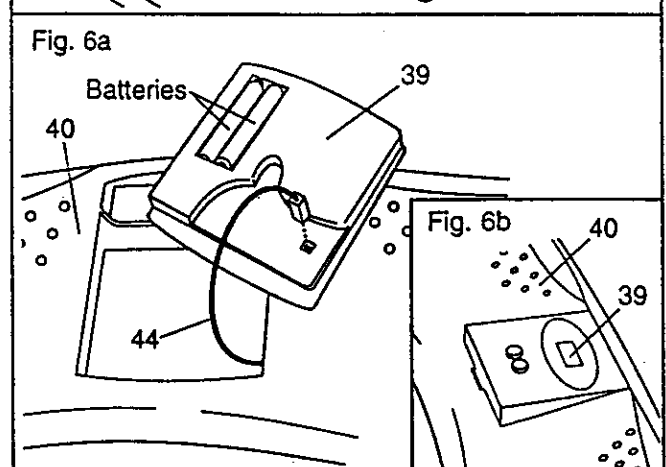

Before you use the AIR WALKER, use the included allen wrench to firmly re-tighten all of the screws used in assembly. Remove the orange and green identification stickers from the AIR WALKER. Note: During the first few minutes that the AIR WALKER is used, a squeaking noise may be heard. This is normal during the break-in period.

HOW TO USE THE AIR WALKER

CAUTION: When you are getting onto and off the AIR WALKER, always tighten the resistance knobs, hold the handles firmly, and be sure that your body weight is centered directly over the pedals.

EXERCISING ON THE AIR WALKER

The proper form for exercising on the AIR WALKER is similar to walking—move one leg forward as you move the other leg back. **Never attempt to move both legs in the same direction—you could be injured, or the AIR WALKER could be damaged.**

For a full body workout, hold the handles as you walk, moving your arms and legs in motion with the handles and pedals. To vary the effect on your muscles, change your stance on the AIR WALKER. For example, you can change the position of your hands on the handles, or you can bend your legs slightly instead of keeping them straight.

For a lower body workout, rest your hands on the edge of the console for balance as you walk on the pedals. **Note: Do not lean on the console. It is not designed to support your body weight.**

RESISTANCE ADJUSTMENT

To vary the intensity of your workout, the resistance of the AIR WALKER can be changed. To increase the resistance, turn both resistance knobs clockwise. To decrease the resistance, turn the resistance knobs counterclockwise.

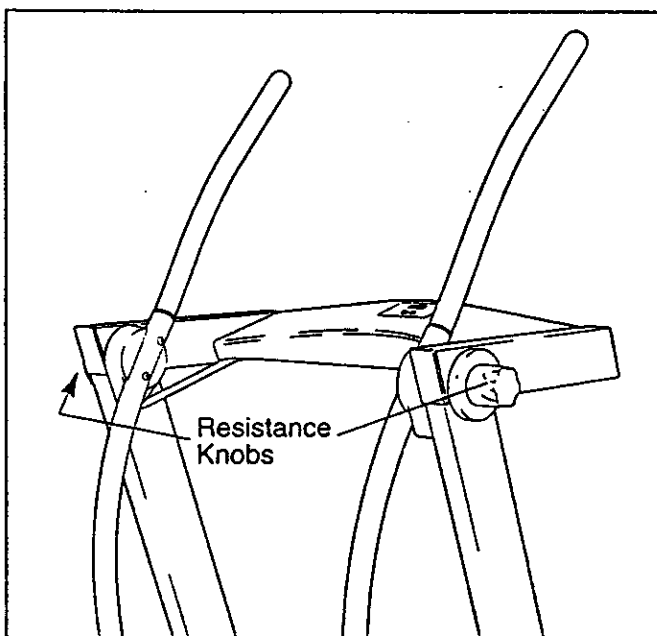

ELECTRONIC MONITOR MODES

The simple-to-operate electronic monitor offers five different modes to provide instant exercise feedback. The five modes are described below:

Reps/min—Displays the number of repetitions you are performing per minute.

Reps—Displays the total number of repetitions you have completed, up to "999." The display will then reset to "0" and continue counting.

Calories—Displays the approximate number of Calories you have burned. Note: If the resistance is near the highest or lowest setting, the actual number of Calories you have burned will be slightly higher or lower than the number displayed.

Scan All—Displays the reps/min, reps, calories, and time modes, for approximately 5 seconds each, in a repeating cycle.

Time—Displays the length of time you have exercised. Note: If you stop exercising for ten seconds or longer, the time mode will pause until you resume.

DIAGRAM OF THE ELECTRONIC MONITOR

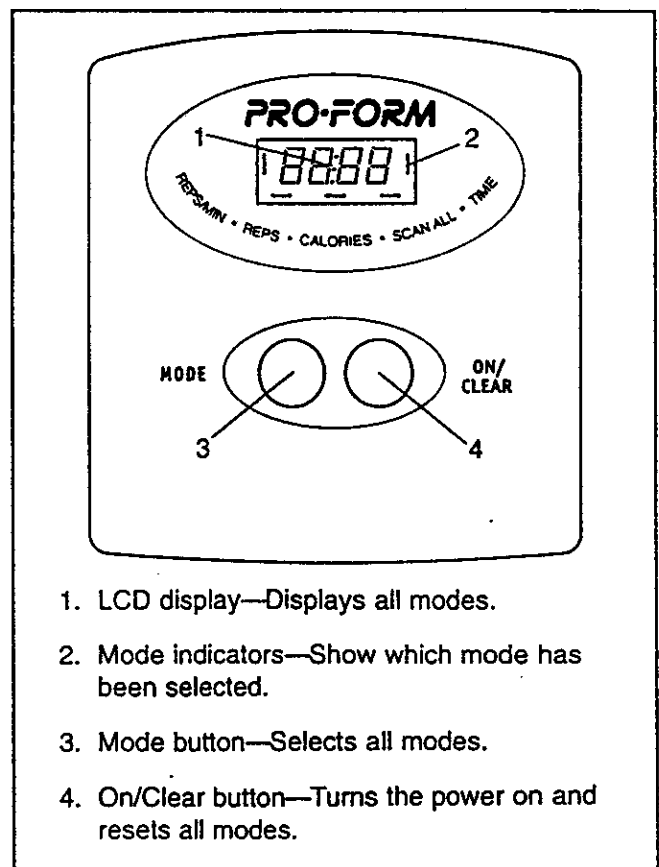

OPERATING THE ELECTRONIC MONITOR

1. To turn on the power, press the on/clear button or simply begin exercising on the AIR WALKER. The entire display will appear for two seconds. The electronic monitor will then be ready for operation.

2. Select one of the five modes:

Scan all mode—When the power is turned on, the scan all mode will be selected automatically. The scan all mode can also be selected by repeatedly pressing the mode button. One mode indicator will show that the scan all mode has been selected, and a second mode indicator will show which mode is currently displayed.

Reps/min, reps, calories, and time modes—These modes can be individually selected by repeatedly pressing the mode button. The mode indicators will show which mode has been selected. (Make sure that the scan all mode is not selected.) The modes will be selected in the following order: reps/min, reps, calories, scan all, time.

3. The monitor has an auto-off feature to turn off the power. If the pedals are not moved and the monitor buttons are not pressed for four minutes, the power will turn off automatically in order to conserve the batteries.

To reset the monitor, press the on/clear button.

MAINTENANCE

Inspect and tighten all parts regularly. Replace any worn parts immediately.

The AIR WALKER can be cleaned with a soft, damp cloth. Keep liquids away from the electronic monitor. Keep the monitor out of direct sunlight or the LCD display may be damaged. Remove the batteries when storing the AIR WALKER.

REPLACING THE BATTERIES

If the display of the electronic monitor becomes dim, the two "AA" batteries should be replaced. Alkaline batteries are recommended.

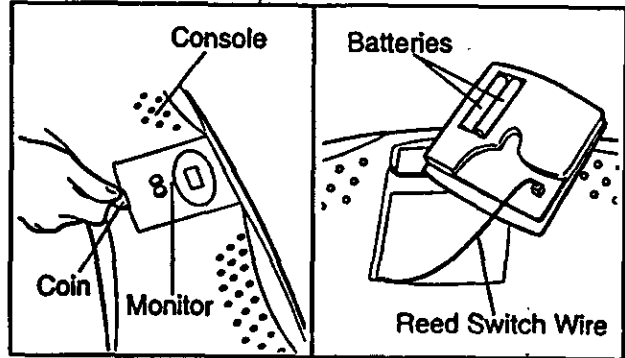

To remove the monitor from the console, gently pry up the monitor with a coin as shown above. Remove the two old batteries from the monitor, and insert two new batteries. Make sure that the negative (-) ends of the batteries are touching the springs, and that the positive (+) ends of the batteries are pushed against the metal contacts.

Make sure that the reed switch wire is plugged into the monitor. Insert any excess wire into the console. Re-insert the monitor into the console. Be careful not to pinch the wire between the console and the monitor.

CONDITIONING GUIDELINES

The following guidelines will help you to plan your exercise program. Remember that proper nutrition and adequate rest are essential for successful results.

WARNING: Before beginning this or any exercise program, consult your physician. This is especially important for individuals over the age of 35 or individuals with pre-existing health problems.

WHY EXERCISE?

Exercise has proven essential for good health and general well-being. Regular participation in a well-rounded exercise program helps to develop a stronger and more efficient heart, improved respiratory function, increased stamina and endurance, better weight management and body fat control, increased ability to deal with stress, and greater self-esteem and confidence.

EXERCISE INTENSITY

To maximize the benefits of exercising, it is important to exercise with the proper intensity. The proper intensity level can be found by using your heart rate as a guide. For effective aerobic exercise, your heart rate should be maintained at a level between 70% and 85% of your maximum heart rate as you exercise. This is known as your training zone. You can find your training zone in the table below. Training zones are listed according to age and physical condition.

AGE	TRAINING ZONE (BEATS / MIN.)	
	UNCONDITIONED	CONDITIONED
20	138-167	133-162
25	136-166	132-160
30	135-164	130-158
35	134-162	129-156
40	132-161	127-155
45	131-159	125-153
50	129-156	124-150
55	127-155	122-149
60	126-153	121-147
65	125-151	119-145
70	123-150	118-144
75	122-147	117-142
80	120-146	115-140
85	118-144	114-139

During the first few months of your exercise program, keep your heart rate near the low end of your training zone as you exercise. After a few months of regular exercise, your heart rate can be increased gradually until it is near the middle of your training zone as you exercise.

To measure your heart rate, stop exercising and place two fingers on your wrist. Take a six-second heartbeat count, and multiply the result by ten to find your heart rate. (A six-second count is used because your heart rate drops quickly when you stop exercising.) If your heart rate is too high, decrease the intensity of your exercise. If your heart rate is too low, increase the intensity of your exercise.

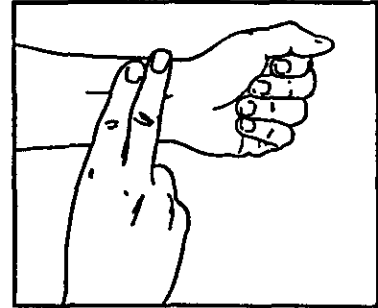

WORKOUT GUIDELINES

A well-rounded workout includes the following three phases:

A warm-up phase, lasting 5 to 10 minutes. Begin with slow, controlled stretches, and progress to more rhythmic stretches. This will increase the body temperature, heart rate, and circulation in preparation for strenuous exercise.

A cardiovascular phase, including 20 to 30 minutes of exercising with your heart rate in your training zone.

A cool-down phase, consisting of 5 to 10 minutes of stretching. Thorough stretching offsets muscle contractions and other problems caused when you stop exercising suddenly. Stretching for increased flexibility is often most effective during this phase. This phase should leave you relaxed and comfortably tired.

To maintain or improve your condition, complete three workouts each week, with at least one day of rest between workouts. After a few months of regular exercise, you may complete up to five workouts each week, if desired. Find the best time of day for your workouts, and then stick with it.

Remember, the key to success is to make exercise a regular and enjoyable part of your everyday life.

PART LIST—Model No. 831.290820

R0396A

Key No.	Qty.	Part No.	Description	Key No.	Qty.	Part No.	Description
1	1	127518	Base	31	8	129475	#8 x 1/2" Screw
2	1	127528	Top Frame	32	1	127896	1/2" x 2" Bolt
3	1	127536	Left Upright	33	2	110576	Pivot Bushing
4	1	127784	Right Upright	34	1	012081	1/2" Nylon Jam Nut
5	1	127539	Rocker Arm	35	2	129110	1" Plastic Washer
6	1	129936	Left Leg	36	6	123116	1 1/2" x 3" Endcap
7	1	129788	Right Leg	37	4	126650	Rubber Foot
8	1	129765	Left Link Arm	38	2	129168	#8 x 1/2" Metal Screw
9	1	129764	Right Link Arm	39	1	127762	Electronic Monitor
10	1	127877	Left Handle	40	1	127761	Console
11	1	127874	Right Handle	41	2	127765	Plastic Sleeve
12	8	119425	3/8" Nylon Jam Nut	42	2	127945	Foam Grip
13	2	129140	Resistance Housing	43	1	110277	#8 x 3/8" Screw
14	2	129570	Resistance Sleeve	44	1	128775	Reed Switch w/Wire
15	2	129139	Friction Cone	45	2	129145	Resistance Cover
16	4	129144	1/2" Thrust Washer	46	2	129146	Resistance Knob
17	2	129143	1/2" Thrust Bearing	47	6	129187	3/8" x 2" Carriage Bolt
18	2	129106	17/32" Plastic Washer	48	1	100498	Magnet
19	1	128714	Right Hub Cover	49	2	129101	#3 x 1/4" Screw
20	1	129770	Right Pivot Bracket	50	2	110468	3/8" Lock Washer
21	2	127887	Pivot Sleeve	51	1	129064	Retainer
22	1	128713	Left Hub Cover	52	1	129065	Magnetic Concentrator
23	1	129768	Left Pivot Bracket	53	6	108404	#8 x 3/4" Metal Screw
24	8	122137	3/8" x 1/2" Screw	54*	1	129063	Console Assembly
25	2	013544	2" Upper Screw	55	2	129763	Leg Saddle
26	2	124123	2 1/4" Lower Screw	56	2	129775	Link Arm Bushing
27	4	127890	3/8" Curved Washer	57	2	101768	Dome Cap
28	2	127759	Pedal	#	1	129939	User's Manual
29	2	013399	3/8" x 1 3/4" Bolt	#	1	045017	Allen Wrench
30	2	052014	Wheel				

* Includes all parts shown in the box

These parts are not illustrated

Note: Specifications are subject to change without notice. See the back cover of this manual for information about ordering replacement parts.

EXPLODED DRAWING—Model No. 831.290820

R0396A

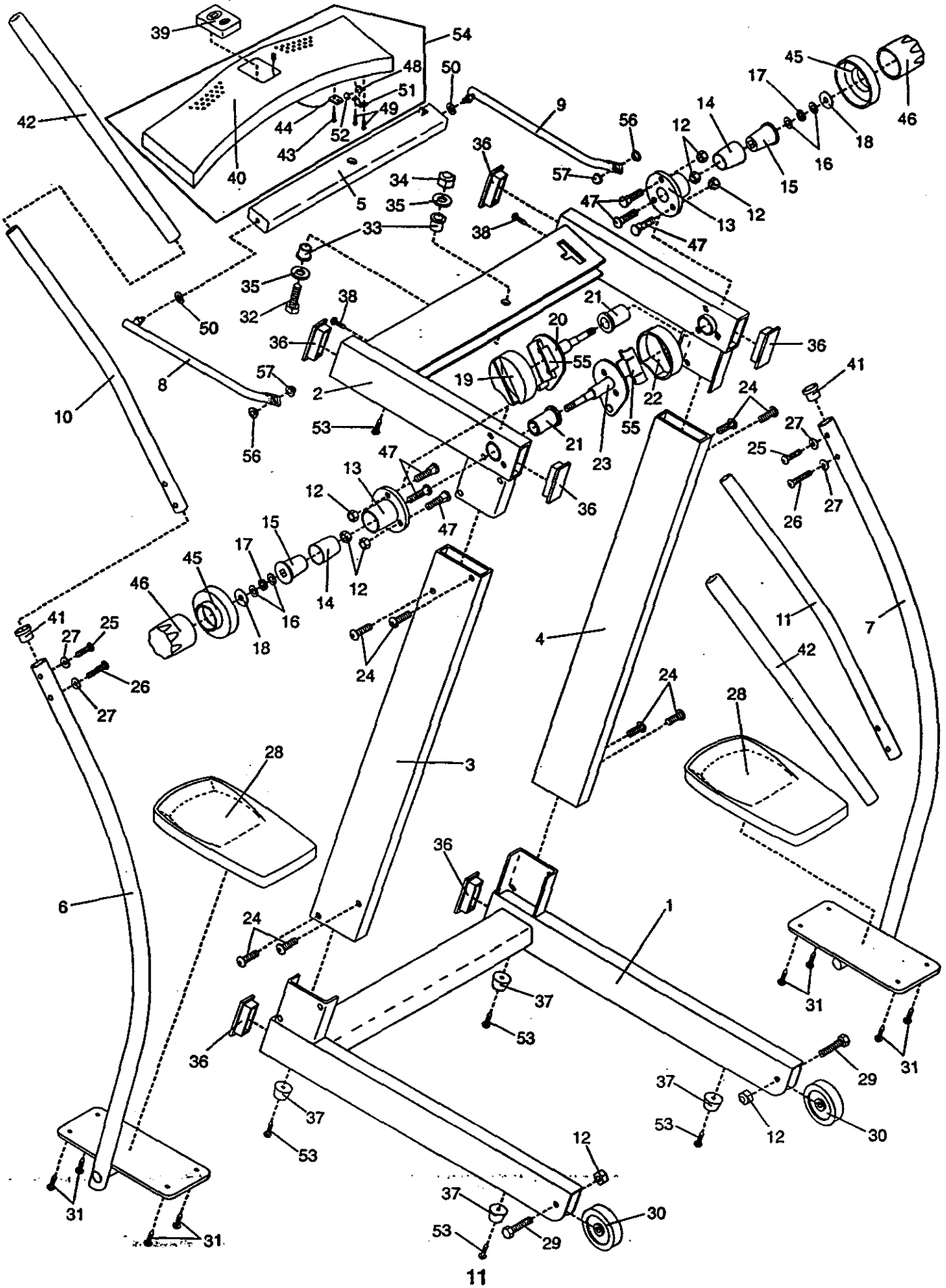

SEARS

Model No. 831.290820

QUESTIONS?

If you find that:

- you need help assembling or operating the PROFORM® AIR WALKER
- a part is missing
- or you need to schedule repair service

call our toll-free HELPLINE

1-800-736-6879

Monday-Saturday, 7 am-7 pm
Central Time (excluding holidays)

REPLACEMENT PARTS

If parts become worn and need to be replaced, call the following toll-free number

1-800-FON-PART
(1-800-366-7278)

The model number and serial number of your PROFORM® AIR WALKER are listed on a decal attached to the frame. See the front cover of this manual to find the location of the decal.

All replacement parts are available for immediate purchase or special order when you visit your nearest SEARS Service Center. To request service or to order parts by telephone, call the toll-free numbers listed at the left.

When requesting help or service, or ordering parts, please be prepared to provide the following information:

- The NAME OF THE PRODUCT (PROFORM® AIR WALKER)
- The MODEL NUMBER OF THE PRODUCT (831.290820)
- The PART NUMBER OF THE PART (see page 10 of this manual)
- The DESCRIPTION OF THE PART (see page 10 of this manual)

FULL 90 DAY WARRANTY

For 90 days from the date of purchase, if failure occurs due to defect in material or workmanship in this AIR WALKER EXERCISER, contact the nearest SEARS Service Center throughout the United States and SEARS will repair or replace the AIR WALKER EXERCISER, free of charge.

This warranty does not apply when the AIR WALKER EXERCISER is used commercially or for rental purposes.

This warranty gives you specific legal rights, and you may also have other rights which vary from state to state.

SEARS, ROEBUCK AND CO., DEPT. 817WA, HOFFMAN ESTATES, IL 60179