

# Lifestyler®

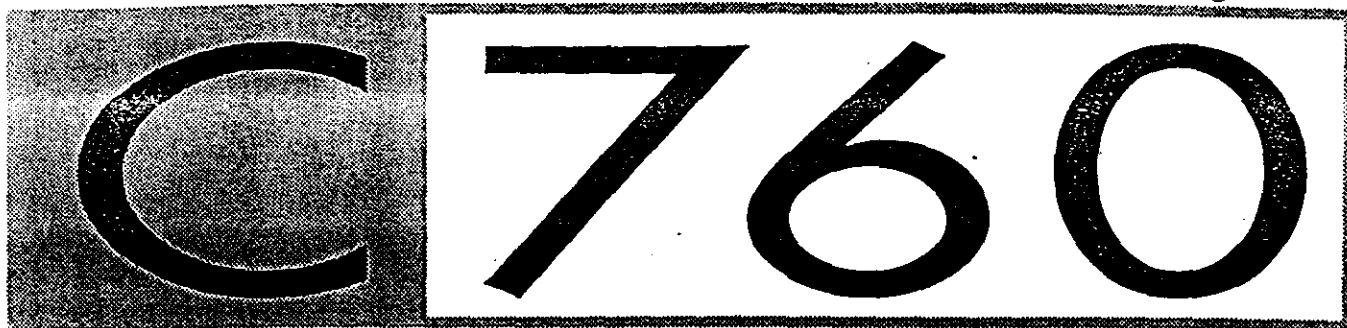

TRIPLE ACTION • ELECTROMAGNETIC SILENT DRIVE

## OWNER'S MANUAL

# SEARS

Model No. 831.287603

Serial No. \_\_\_\_\_

The serial number can be found in the location shown below. Write the serial number in the space above.

Serial Number Decal

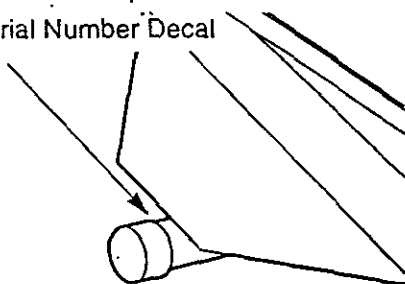

EXERCISE  
EQUIPMENT

**QUESTIONS**

HELPLINE!

1-800-736-6879

### CAUTION!

Read all safety precautions and instructions in this manual before using this equipment. Keep this manual in a safe place for future reference.

PATENT PENDING

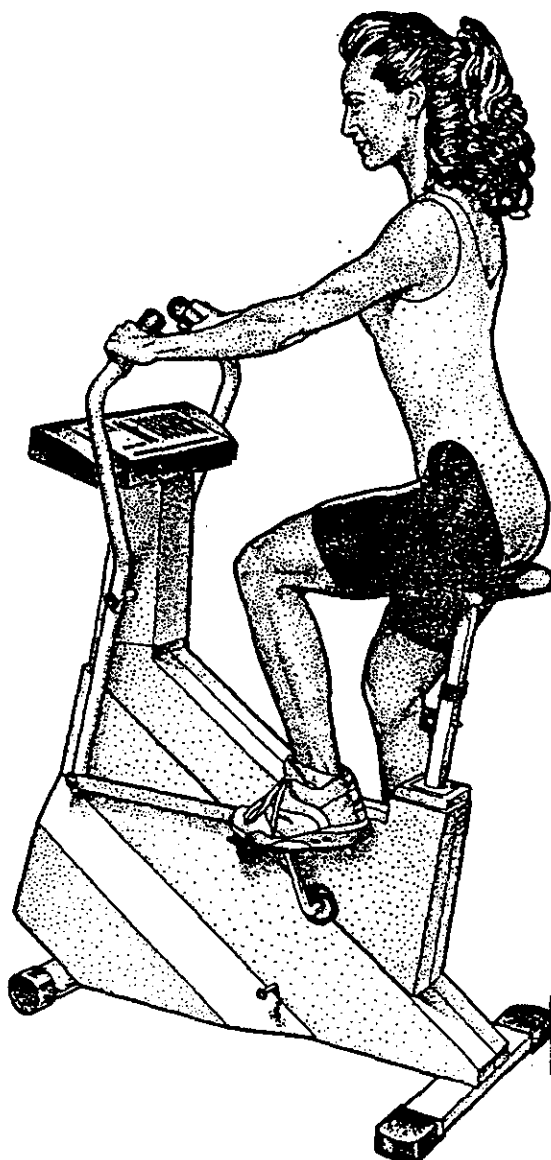

SEARS, ROEBUCK AND CO., HOFFMAN ESTATES, IL 60179

---

# TABLE OF CONTENTS

IMPORTANT SAFETY PRECAUTIONS .....	2
BEFORE YOU BEGIN .....	3
ASSEMBLY .....	4
ADJUSTMENT AND OPERATION .....	8
TROUBLE-SHOOTING AND MAINTENANCE .....	11
CONDITIONING GUIDELINES .....	12
PART LIST .....	14
EXPLODED DRAWING .....	15
ORDERING REPLACEMENT PARTS .....	Back Cover
LIMITED WARRANTY .....	Back Cover

---

## IMPORTANT SAFETY PRECAUTIONS

**WARNING:** To reduce the risk of serious injury, read the following important safety precautions before using the exercise bike.

1. Place the exercise bike on a level surface. Do not use the bike near water or outdoors.
2. Use the exercise bike only as described in this manual.
3. Keep small children away from the exercise bike at all times.
4. Wear appropriate clothing when exercising; do not wear loose clothing that could become caught in the exercise bike. Always wear athletic shoes for foot protection.
5. When connecting the link arms to the pedals (see HANDLEBAR OPERATION on page 8), make sure that the link arms are on the pedal bushings. If the link arms are not on the pedal bushings, they may slip off during use, resulting in injury.
6. When adjusting the seat, at least two inches of the seat post must be inside of the frame. The seat pin must be inserted from the front, as shown on page 3. If the seat pin is inserted from the back, it may slip out during use, resulting in injury.

**WARNING:** Before beginning this or any exercise program, consult your physician. This is especially important for persons over the age of 35 or persons with pre-existing health problems. Read all instructions before using this product. SEARS assumes no responsibility for personal injury or property damage sustained by or through the use of this product.

# BEFORE YOU BEGIN

Congratulations for selecting the SEARS LIFESTYLER® C 760 exercise bike. Cycling is one of the most effective exercises known for increasing cardiovascular fitness, building endurance, and toning the entire body. The sophisticated LIFESTYLER C 760 offers an impressive array of features to let you enjoy this healthful exercise in the convenience and privacy of your home.

For your safety and benefit, read this manual carefully before using the exercise bike. If you have additional questions, please call our Customer Service

Department toll-free at 1-800-736-6879, Monday through Saturday, 7 a.m. until 7 p.m. Central Time (excluding holidays). To help us assist you, please mention the product model number and serial number when calling. The model number is 831.287603. The serial number can be found on a decal attached to the exercise bike (see the front cover of this manual for the location of the decal).

Before reading further, please review the drawing below and familiarize yourself with the parts that are labeled.

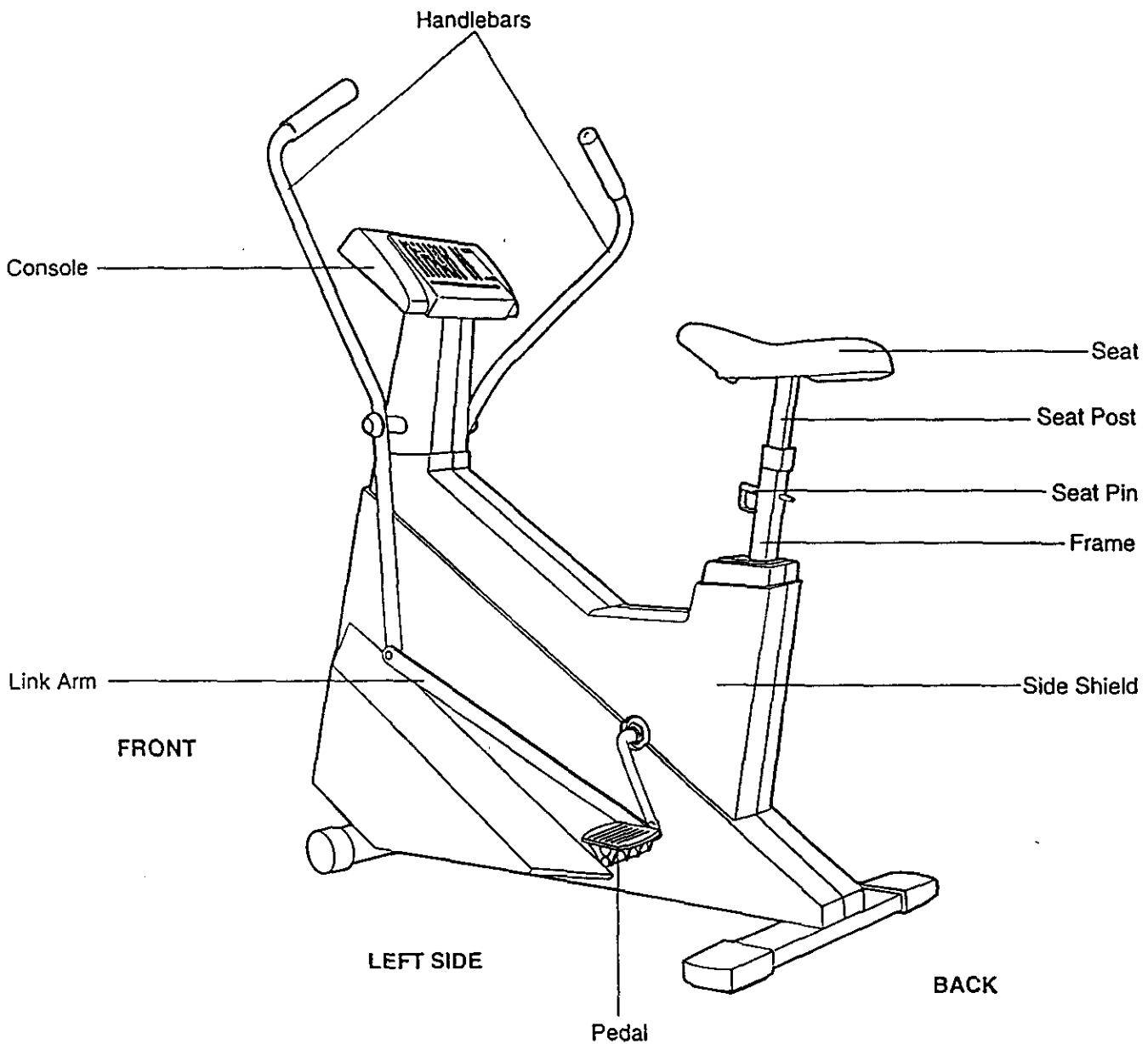

# ASSEMBLY

Place all parts of the exercise bike in a cleared area and remove the packing materials. Do not dispose of the packing materials until assembly is completed.

Read all steps and examine all drawings carefully.

Use the drawings below to identify the small parts used in assembly. The number in parenthesis beneath each part refers to the key number of the part. The second number refers to the quantity used in assembly. Note: Some small parts may have been pre-attached for shipping purposes. If a

part is not found in the parts bag, check to see if it has been pre-attached,

In addition to the tools included, the following tools are required for assembly:

one (1) hammer 

one (1) adjustable wrench 

one (1) phillips screwdriver 

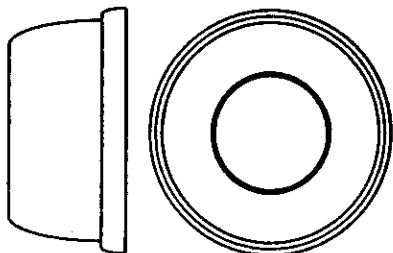

5/8" Plastic Cap (3)-2

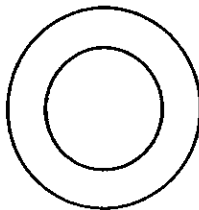

5/8" Handlebar Spacer (75)-2

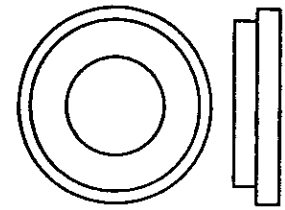
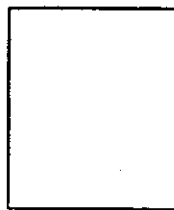

Pedal Bushing (55)-2

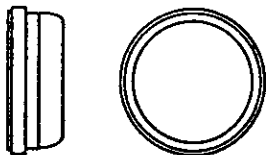

Pedal Cap (50)-2

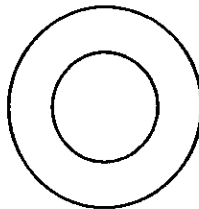

9/16" Pedal Spacer (73)-2

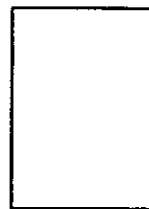

Link Arm Bushing (58)-2



5/16" Pedal Nut (49)-2

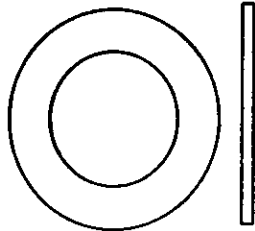

11/16" Washer (54)-2

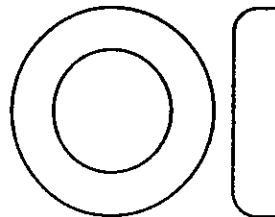

5/8" Spacer (57)-2

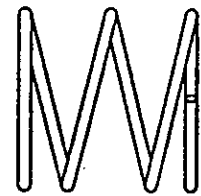

Pedal Spring (52)-2



1/4" Seat Nut (7)-4

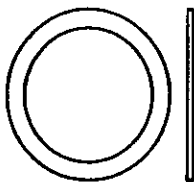

11/16" Spring Washer (51)-2

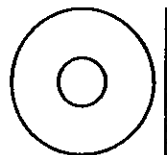

5/16" Washer (65)-2



3/4" Phillips Screw (4)-4



5/16" x 18 Nylon Locknut (17)-2

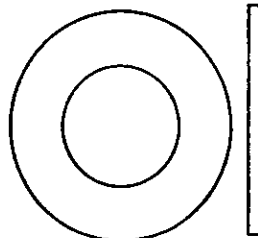

9/16" Washer (56)-2



5/16" x 1/2" Screw (33)-2

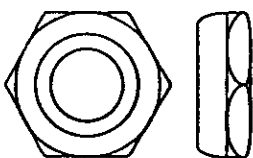

1/2" Nylon Locknut (46)-2

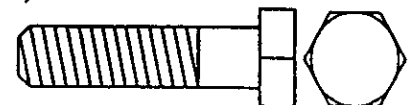

5/16" x 1 1/4" Bolt (14)-2

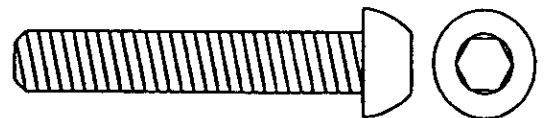

5/16" x 1 3/4" Bolt (36)-2

1. Raise the back end of the exercise bike. Attach the Stabilizer (13) to the Frame (11) with the two 5/16" x 1 1/4" Bolts (14). The Stabilizer must be turned so the ribbed sides of the Endcaps (12) are on the side shown. Lower the exercise bike.

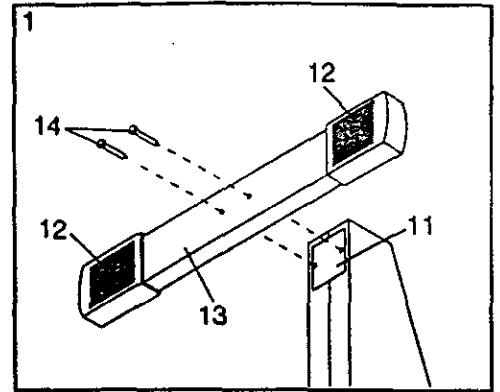

2. Slide the free end of the Roller Axle (42) through the Bushings (43) in the Frame (11). Press the unattached Roller (24) onto the end of the Axle. It may be helpful to tap the Roller with a hammer in order to press it fully onto the Axle.

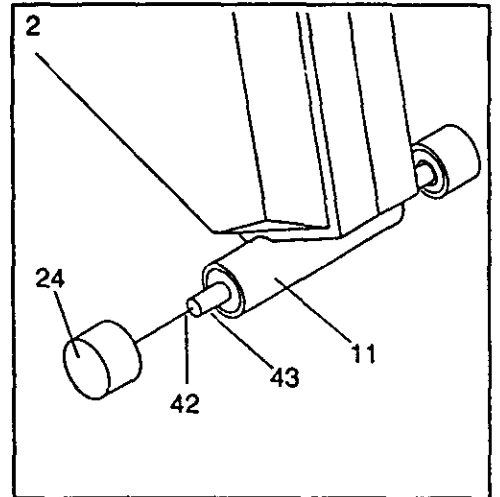

3. Remove the four 1/4" Seat Nuts (7) from the underside of the Seat (5). Remove the Seat Post (6) from the Frame (11). Attach the Seat to the top of the Seat Post with the four 1/4" Seat Nuts.

Insert the Seat Post (6) into the Frame (11). Adjust the Seat (5) to the desired height, and insert the Seat Pin (8) through the front of the Frame and the Seat Post. Slide the Seat Post Collar (30) down over the Frame. **CAUTION:** At least two inches of the Seat Post must be inside of the Frame. The Seat Pin must be inserted from the front, as shown. If the Seat Pin is inserted from the back, it may slip out, resulting in injury.

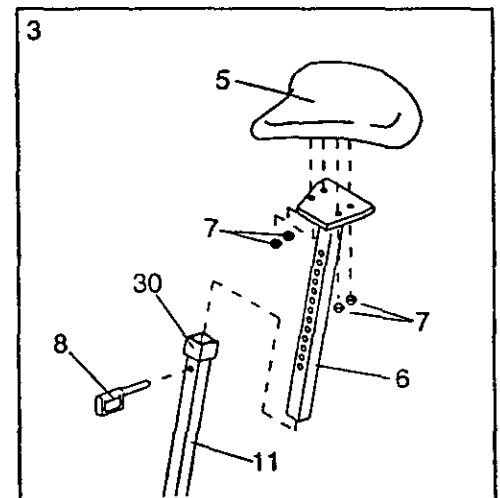

4. Connect the wire protruding from the Console Mount (2) to the Wire Harness (66) (see the inset drawing). Make sure that the wire is turned so it fits easily into the Wire Harness. If the wire is not turned correctly and is forced into the Wire Harness, the Console (1) will not function properly.

Slide the Console Mount (2) onto the Frame (11). **CAUTION:** Be careful to avoid pinching your fingers or the Wire Harness (66). Attach the Console Mount to the Frame with the two 5/16" x 1/2" Screws (33).

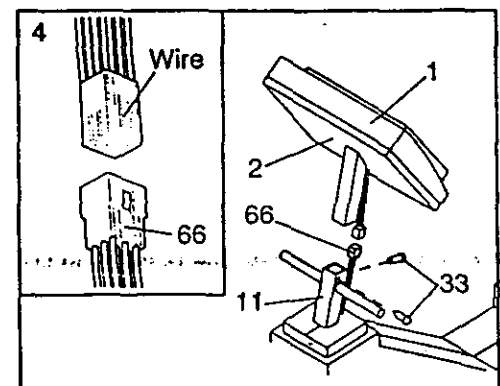

5. Plug the Power Cord (70) into the jack at the back of the exercise bike. Test the console in the following manner:

A. Plug the transformer on the Power Cord (70) into a 120-volt outlet.

B. Press the power button on the console (see the drawing at the top of page 9). The manual mode indicator will light and the LCD display will appear. Next, move the manual resistance control. You will hear the motor as the resistance changes. Next, press the program/manual button. The program mode indicator and the eight segment indicators will light.

If the console does not function as described, see assembly step 4. Make sure that the wire is plugged correctly into the wire harness.

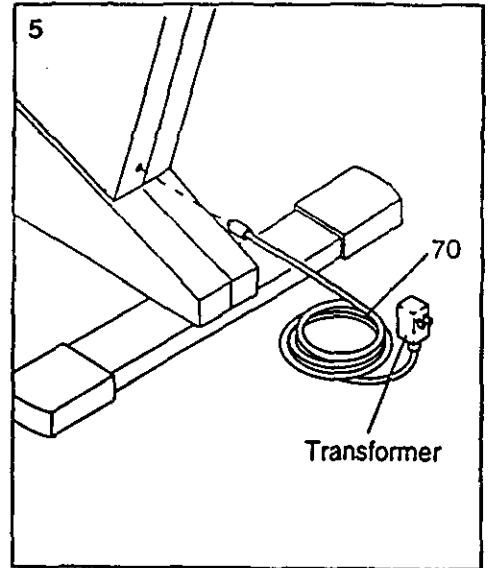

6. Apply grease (included) to the handlebar shaft of the Frame (11). Slide a 5/8" Spacer (57) and a 5/8" Handlebar Spacer (75) onto each side of the handlebar shaft. Make sure that the open side of each 5/8" Spacer is turned toward the Frame.

Slide the Left and Right Neck Shields (67, 68) onto the handlebar shaft of the Frame (11). Insert the four 3/4" Phillips Screws (4) into the Left Neck Shield, and tighten them into the Right Neck Shield.

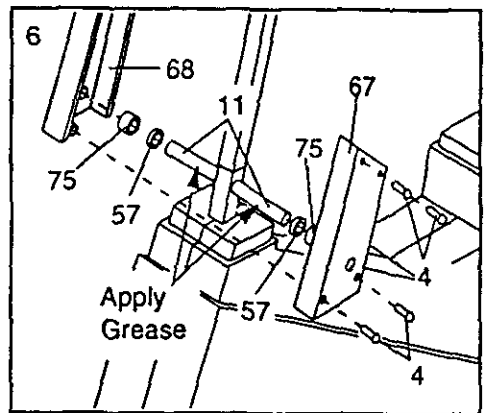

7. Slide a Handlebar (9) onto the left side of the handlebar shaft of the Frame (11). Tap a 5/8" Plastic Cap (3) onto the handlebar shaft.

Attach the other Handlebar in the same manner (not shown).

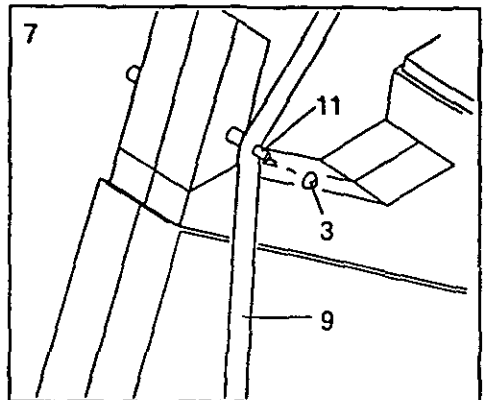

8. Insert a 5/16" x 1 3/4" Bolt (36) through the lower end of the left Handlebar (9). **CAUTION: The lower end of the Handlebar may have a rough edge. Be careful to avoid cutting your fingers.** Tap a Link Arm Bushing (58) into a Link Arm (37). Slide the Link Arm onto the Bolt. The flange of the Link Arm Bushing must be turned toward the Handlebar, and the opening in the end of the Link Arm must be downward as shown. Tighten a 5/16" x 18 Nut (17) onto the Bolt. Do not overtighten the Nut; the Link Arm must pivot freely. Clip the Link Arm onto the lock rod.

Attach the other Link Arm to the right Handlebar in the same manner (not shown).

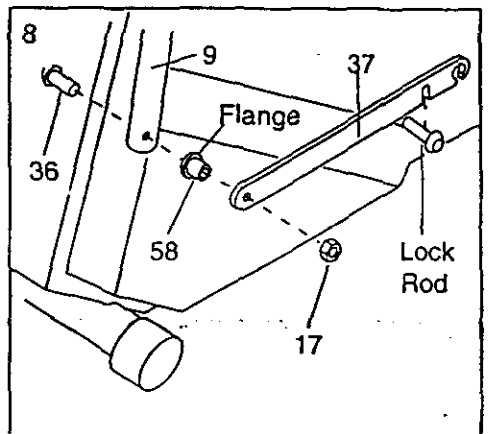

9. Hold one of the Pedal Shafts (38) with the included tool as shown—the tool must be between the coils of the Pedal Spring (52). Using an adjustable wrench, remove the 1/2" Nylon Locknut (46) from the end of the Pedal Shaft. (There is an 11/16" Spring Washer (51), a Pedal Spring (52), an 11/16" Washer (54), a Pedal Bushing (55), a 9/16" Washer (56) and a 9/16" Pedal Spacer (73) on the Pedal Shaft.) Using the included tool, firmly tighten the Pedal Shaft, in a clockwise direction, into one of the arms of the Crank (27). While holding the Pedal Shaft with the included tool, use an adjustable wrench to tighten the 1/2" Nylon Locknut (46) onto the end of the Pedal Shaft. (There is a 5/16" Washer (65) and a 5/16" Pedal Nut (49) on the other end of the Pedal Shaft. The 5/16" Pedal Nut (49) must be flush with the end of the Pedal Shaft.) Press a Pedal Cap (50) into the Pedal (10).

Attach the other Pedal Shaft to the other arm of the Crank in the same manner (not shown).

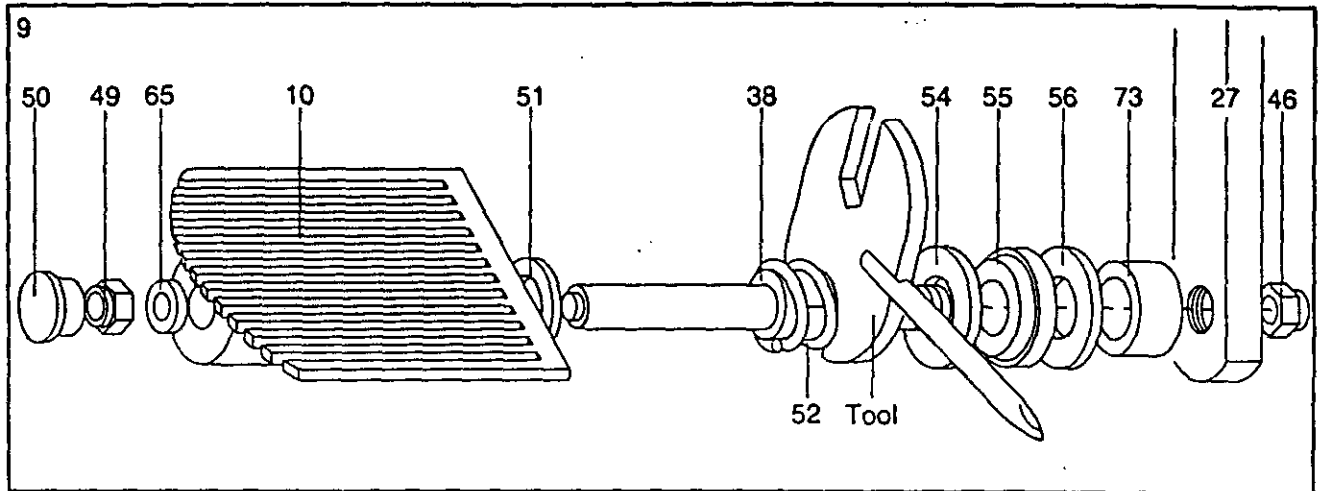

# ADJUSTMENT AND OPERATION

## CONNECTING THE POWER CORD

Plug the transformer on the power cord into a 120-volt outlet. Keep the power cord away from walkways and heated surfaces. Turn on the power when using the exercise bike or the bike could be damaged.

## SEAT ADJUSTMENT

For effective exercise, the Seat (5) should be adjusted to the proper height. As you pedal, there should be a slight bend in your knees when the pedals are at the lowest position. Dismount the exercise bike. Hold the Seat and remove the Seat Pin (8). Adjust the Seat to the proper height and insert the Seat Pin through the Frame (11) and the Seat Post (6). **CAUTION:** At least two inches of the Seat Post must be inside of the Frame. The Seat Pin must be inserted from the front, as shown. If the Seat Pin is inserted from the back, it may slip out during use, resulting in injury.

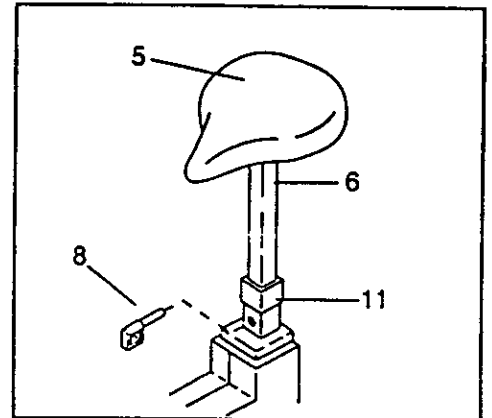

## HANDLEBAR OPERATION

The handlebars can be used in any of three modes: the dual-action mode, for lower- and upper-body exercise; the stationary mode, for lower-body exercise; or the rowing mode, for upper-body exercise.

### DUAL-ACTION MODE

To use the handlebars in the dual-action mode, the Link Arms (37) must be connected to the pedals. First, lift the Link Arms off the lock rod (see drawing 1). Pull the Link Arms outward against the tops of the 11/16" Washers (54), while pulling against the bottoms of the 11/16" Washers with your fingers (see drawing 2). **CAUTION:** Be careful to avoid pinching your fingers. Slide the Link Arms onto the Pedal Bushings (55). It may be helpful to move the Link Arms up and down slightly until they slide onto the Pedal Bushings. **CAUTION:** Make sure that the Link Arms are on the Pedal Bushings. If the Link Arms are not on the Pedal Bushings, they may slip off during use, resulting in injury.

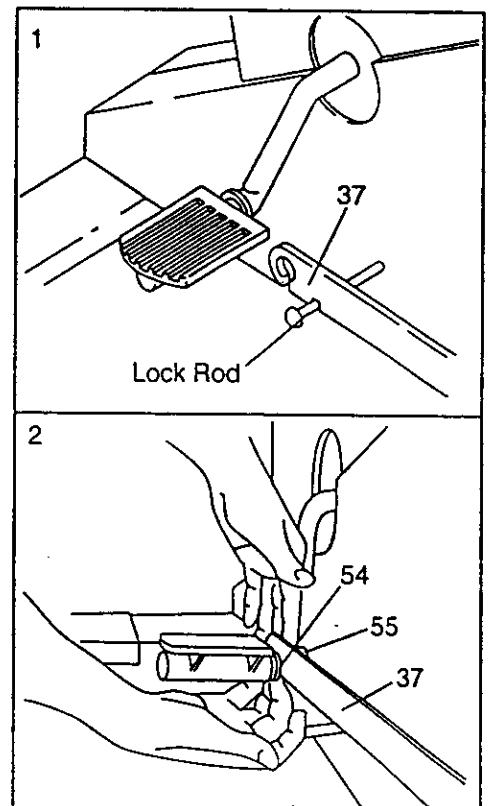

### STATIONARY MODE

To use the handlebars in the stationary mode, the Link Arms (37) must be disconnected from the pedals. Pull the Link Arms outward against the 11/16" Washers (54), until the Link Arms can be lifted off the Pedal Bushings (55) (see drawing 2). **CAUTION:** Be careful to avoid pinching your fingers. Clip the Link Arms onto the lock rod (see drawing 1).

### ROWING MODE

To use the handlebars in the rowing mode, the Link Arms (37) must be connected to the pedals (see DUAL-ACTION MODE above). Rest your feet on the side shields, and exercise using only your arms.



## DIAGRAM OF THE CONSOLE

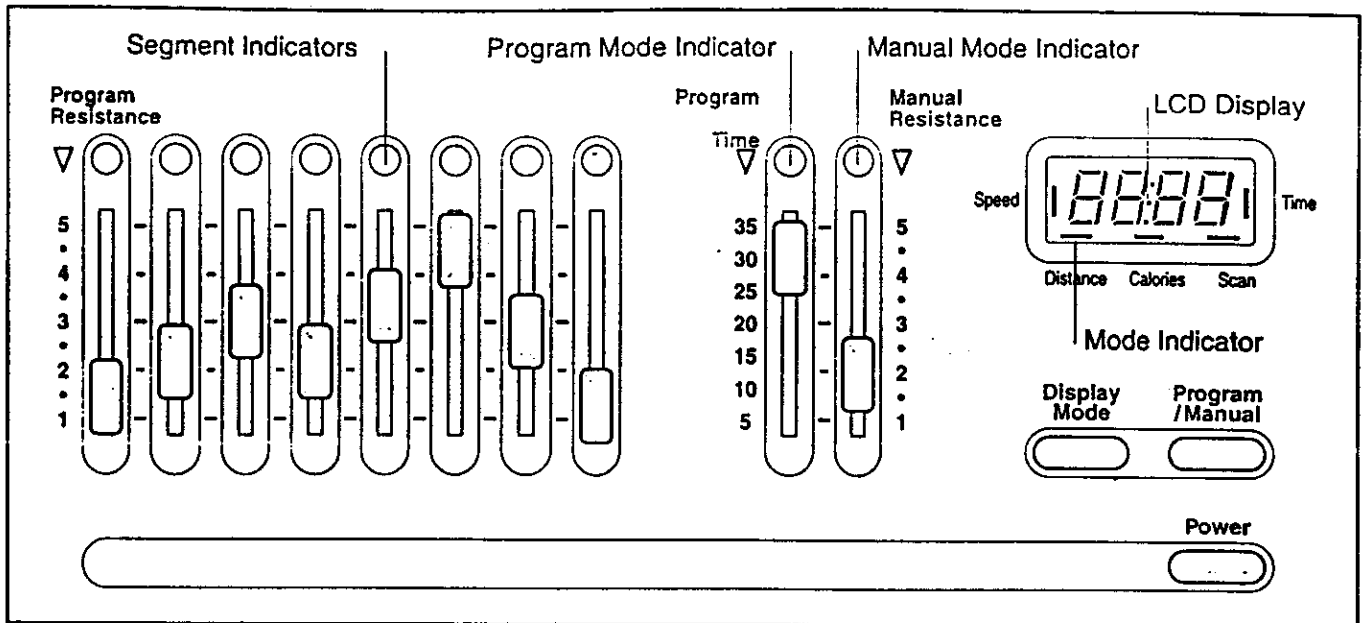

### DESCRIPTION OF THE CONSOLE

The heart of the exercise bike is the programmable console. The console offers both manual and program modes, and features a multiple-mode exercise monitor to provide you with instant feedback during your workouts. Remove the clear plastic film from the front of the console. Please read these instructions carefully before operating the console.

### TURNING ON THE POWER

To turn on the power, press the power button or simply begin pedaling. The manual mode indicator will light and the LCD display will appear.

### MANUAL MODE

When the power is turned on, the console will be in the manual mode. As you pedal, the pedaling resistance can be changed by moving the manual resistance control. To increase the resistance, move the control upward; to decrease the resistance, move the control downward. After the control is moved, it will take a few seconds for the exercise bike to reach the selected resistance setting.

### PROGRAM MODE

When the console is in the program mode, the pedaling resistance will be controlled by programs you create. Each program will consist of eight equal time periods, called segments. The resistance will change automatically at the beginning of each segment. To create a program, a resistance setting should be programmed for each of the eight segments by moving

the eight program resistance controls on the left side of the console. The control at far left is for the first segment, and the control at far right is for the eighth segment. To program resistance settings, move the controls to the desired positions. The higher the controls are moved, the higher the resistance settings will be. A sample program is shown above. This program will begin with a low resistance setting. The resistance will then increase during the second and third segments, decrease during the fourth segment, increase again during the fifth and sixth segments, and decrease during the seventh and eighth segments. An infinite variety of settings can be programmed.

Next, move the program time control to set the length of time you want the program to last. The program can be set to last for a minimum of 5 minutes, up to a maximum of 35 minutes.

To start the program, press the program/manual button and begin pedaling. The program mode indicator and the eight segment indicators will light, and the exercise bike will automatically adjust to the setting of the first program resistance control. After one-eighth of the length of time you set has elapsed, the first segment indicator will darken, and the exercise bike will automatically adjust to the setting of the second program resistance control. The program will continue in this manner until all eight segment indicators are dark.

While the program is in progress, the pedaling resistance can be changed during the current segment, if desired, by moving the program resistance control for the current segment. If desired, the program can be stopped or the console can be switched to the manual mode by pressing the program/manual button.

## EXERCISE MONITOR MODES

The exercise monitor features five different modes:

**SPEED**—Displays your pedaling speed, in miles per hour.

**TIME**—Displays the elapsed time. Note: Time will be counted only while you are pedaling. If you stop for ten seconds or longer, the TIME mode will hold until you resume pedaling.

**DISTANCE**—Displays the total distance you have pedaled, in miles.

**CALORIE**—Displays the total number of Calories you have burned. Note: If the pedaling resistance is near the lowest or highest setting, the actual number of Calories you have burned will be slightly lower or higher than the number displayed.

**SCAN**—Displays the SPEED, TIME, DISTANCE and CALORIE modes, for five seconds each, in a repeating cycle.

## EXERCISE MONITOR OPERATION

When the power is turned on, the SCAN mode will be selected automatically. One mode indicator will appear by the word "SCAN." The SPEED, TIME, DISTANCE and CALORIE modes will be displayed in a repeating cycle. A second mode indicator will show which mode is currently displayed.

If desired, the SPEED, TIME, DISTANCE or CALORIE mode can be selected for continuous display by repeatedly pressing the display mode button. The modes will be selected in the following order: SPEED, TIME, DISTANCE, CALORIE, SCAN.

To reset the LCD display, turn the power off and then on again by pressing the power button twice.

## TURNING OFF THE POWER

When you are finished exercising, press the power button to turn off the power. Note: If the pedals are not moved and the controls are not used for four minutes, the power will turn off automatically.

# TROUBLE-SHOOTING AND MAINTENANCE

Inspect and tighten all parts regularly. Outer surfaces of the exercise bike can be cleaned using a damp cloth and mild, non-abrasive detergent. Keep liquids away from the console.

## CONSOLE

If the console does not function properly, the wire harness should be checked. See assembly step 4 on page 5. Make sure that the wire harness is plugged fully into the wire extending from the console.

## ADJUSTING THE TENSION BELT

If the tension belt slips as you pedal, the tension belt should be tightened. First, disconnect the Link Arms (37) from the Pedals (10) (see STATIONARY MODE on page 8). Next, remove the Pedals (see assembly step 9 on page 7). Remove the four 3/4" Phillips Screws (4) from the Left and Right Neck Shields (67, 68). Remove the #8 x 1" Screws (15) and the 3/4" Tec Screws (69) from the Left and Right Side Shields (16, 34). Slide the Side Shields off the exercise bike. To tighten the tension belt, turn both of the 1/4" Nylon Locknuts (18) clockwise one full turn. Repeat until the tension belt no longer slips. Reattach the Side Shields, Neck Shields and Pedals.

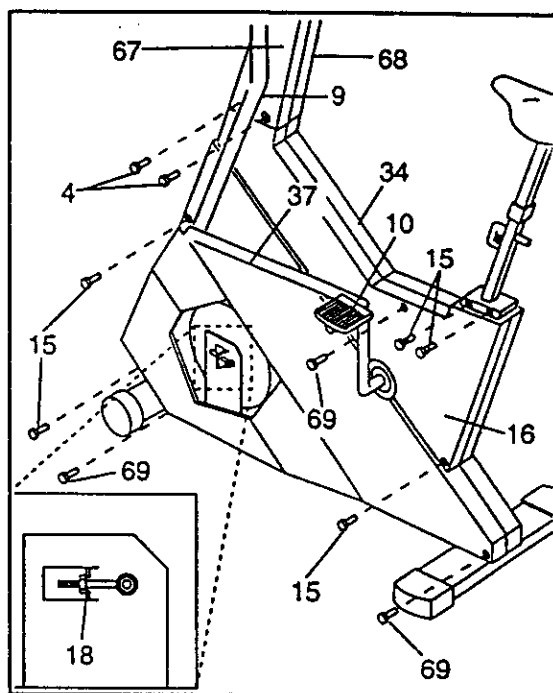

## CENTERING THE TENSION BRACKET

If a grinding noise is heard as you pedal, the Tension Bracket (35) should be adjusted. Disconnect the link arms from the pedals, remove the pedals, and remove the side shields (see ADJUSTING THE TENSION BELT above). Hold the 3/8" x 16 Nut (72) with a wrench. If the Tension Bracket is touching the right side of the Resistance Disk (22), turn the Tension Bracket Bolt (60) clockwise until the Tension Bracket is centered. If the Tension Bracket is touching the left side of the Resistance Disk, turn the Bolt counterclockwise. Reattach the side shields, neck shields and pedals.

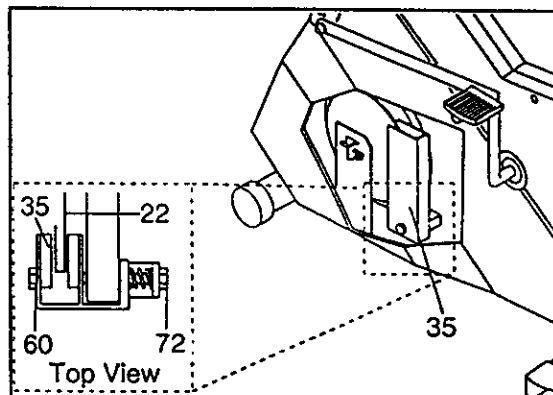

## TIGHTENING THE CRANK ARMS

If the crank arms become loose, they should be tightened in order to prevent excessive wear. Loosen the hex nut on the left arm of the Crank (27). Place the end of a standard screwdriver in one of the grooves in the crank nut. Lightly tap the screwdriver with a hammer to turn the crank nut counterclockwise, until the crank arms are no longer loose. **Do not overtighten the crank nut.** When the crank nut is properly tightened, tighten the hex nut.

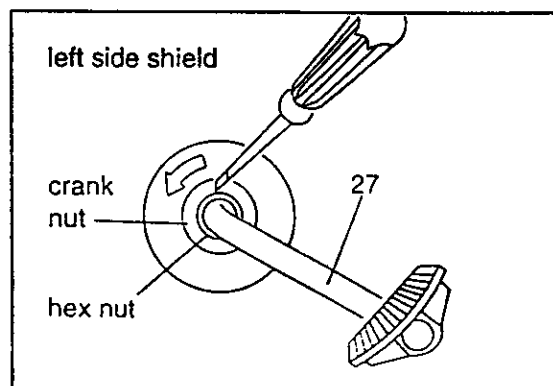

# CONDITIONING GUIDELINES

The following guidelines will help you to plan your exercise program. Remember that proper nutrition and adequate rest are essential for successful results.

**WARNING:** Before beginning this or any exercise program, consult your physician. This is especially important for persons over the age of 35 or persons with pre-existing health problems.

## EXERCISE INTENSITY

To maximize the benefits of exercising, it is important to exercise with the proper intensity. The proper intensity level can be found by using your heart rate as a guide. For effective aerobic exercise, your heart rate should be maintained at a level between 70% and 85% of your maximum heart rate as you exercise. This is known as your training zone.

You can find your training zone in the table below. Training zones are listed for both unconditioned and conditioned persons according to age.

AGE	UNCONDITIONED TRAINING ZONE (BEATS/MIN)	CONDITIONED TRAINING ZONE (BEATS/MIN)
20	138-167	133-162
25	136-166	132-160
30	135-164	130-158
35	134-162	129-156
40	132-161	127-155
45	131-159	125-153
50	129-156	124-150
55	127-155	122-149
60	126-153	121-147
65	125-151	119-145
70	123-150	118-144
75	122-147	117-142
80	120-146	115-140
85	118-144	114-139

During the first few months of your exercise program, keep your heart rate near the low end of your training zone as you exercise. After a few months, your heart rate can be increased gradually until it is near the middle of your training zone as you exercise.

To measure your heart rate, stop exercising and place two fingers on your wrist. Take a six-second heartbeat count, and

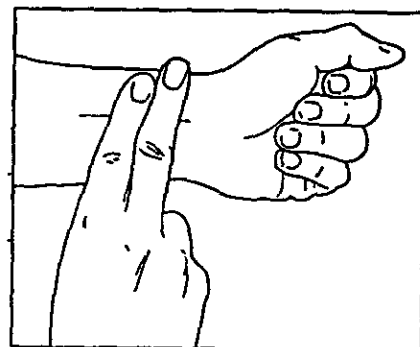

multiply the result by 10 to find your heart rate. For example, if your six-second heartbeat count is 14, your heart rate is 140 beats per minute. (A six-second count is used because your heart rate will drop rapidly when you stop exercising.) Adjust the intensity of your exercise until your heart rate is at the proper level.

## WORKOUT GUIDELINES

Each workout should consist of three basic parts: a warm-up, 20 to 30 minutes of training zone exercise, and a cool-down.

Warming up prepares the body for exercise by increasing circulation, delivering more oxygen to the muscles and raising the body temperature. Begin each workout with 5 to 10 minutes of stretching and light exercise to warm up. Then, increase the intensity of your exercise to raise your heart rate to your training zone for 20 to 30 minutes. Breathe regularly and deeply as you exercise—never hold your breath. Finish each workout with 5 to 10 minutes of stretching to cool down. This will increase the flexibility of the muscles, and reduce soreness and other post-exercise problems.

To maintain or improve your condition, complete three workouts each week, with at least one day of rest between workouts. After a few months of regular exercise, you may complete up to five workouts each week, if desired. The key to success is to make exercise a regular and enjoyable part of your everyday life.

## SUGGESTED STRETCHES

The following stretches can provide a good warm-up or cool-down. Correct form for each stretch is shown in the drawings below. Move slowly as you stretch—never bounce.

### TOE TOUCH STRETCH

Stand with your knees bent slightly and slowly bend forward from your hips. Allow your back and shoulders to relax as you reach down toward your toes as far as possible. Hold for 15 counts, then relax. Repeat 3 times.

Stretches: Hamstrings, back of knees and back.

### HAMSTRING STRETCH

Sit with one leg extended. Bring the sole of the opposite foot toward you and rest it against the inner thigh of your extended leg. Reach toward your toes as far as possible. Hold for 15 counts, then relax. Repeat 3 times for both legs.

Stretches: Hamstrings, lower back and groin.

### CALF/ACHILLES STRETCH

With one leg in front of the other, reach forward and place your hands against a wall. Keep your back leg straight and your back foot flat on the floor. Bend your front leg, lean forward and move your hips toward the wall. Hold for 15 counts, then relax. Repeat 3 times for both legs. To cause further stretching of the achilles tendons, bend your back leg as well.

Stretches: Calves, achilles tendons and ankles.

### QUADRICEPS STRETCH

With one hand against a wall for balance, reach back and grasp one foot with your other hand. Bring your heel as close to your buttocks as possible. Hold for 15 counts, then relax. Repeat 3 times for both legs.

Stretches: Quadriceps and hip muscles.

### INNER THIGH STRETCH

Sit with the soles of your feet together and your knees outward. Pull your feet toward your groin area as far as possible. Hold for 15 counts, then relax. Repeat 3 times.

Stretches: Quadriceps and hip muscles.

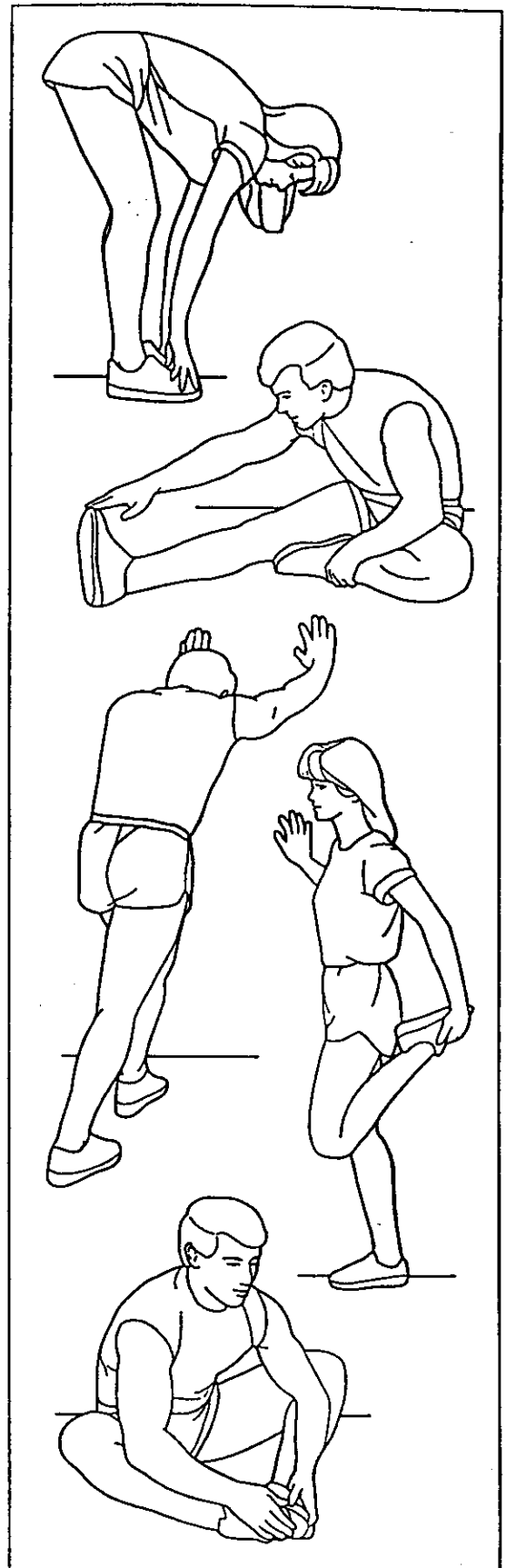

# PART LIST—Model No. 831.287603

R0396A

Key No.	Part No.	Qty.	Description	Key No.	Part No.	Qty.	Description
1	123213 <del>148751</del>	1	Console	42	106698	1	Roller Axle
2	123786	1	Console Mount	43	106880	2	Roller Bushing
3	100151	2	5/8" Plastic Cap	44	013423	1	#8 x 1/2" Screw
4	013300	8	3/4" Phillips Screw	45	104787	1	Seat Post Glide
5	105022	1	Seat	46	100904	2	1/2" Nylon Locknut
6	116605	1	Seat Post	47	110465	1	Crank Hardware
7	012096	4	1/4" Seat Nut	48	013162	2	#8 x 1/2" Self-tapping Screw
8	116675	1	Seat Pin	49	012146	2	5/16" Pedal Nut
9	117009	2	Handlebar	50	112704	2	Pedal Cap
10	112701	2	Pedal	51	101456	2	11/16" Spring Washer
11	NSP	1	Frame	52	103571	2	Pedal Spring
12	105590	2	Endcap	53	115778	1	Tension Motor
13	123489	1	Stabilizer	54	101460	2	11/16" Washer
14	013469	2	5/16" x 1 1/4" Bolt	55	101036	2	Pedal Bushing
15	013294	10	#8 x 1" Screw	56	101494	2	9/16" Washer
16	120760	1	Left Side Shield	57	108668	2	5/8" Spacer
17	012056	2	5/16" x 18 Nut	58	100364	2	Link Arm Bushing
18	012090	2	1/4" Nylon Locknut	59	101768	2	3/8" Axle Cap
19	113788	1	Small Spacer	60	104925	1	Tension Bracket Bolt
20	113834	2	Bearing	61	100498	1	Magnet
21	113789	1	Large Spacer	62	101049	2	3/16" x 1/2" Screw
22	119198	1	Resistance Disk	63	012082	2	5/16" Flange Nut
23	113791	1	Flywheel Axle	64	104536	2	Eye Bolt
24	106697	2	Roller	65	014041	2	5/16" Washer
25	119227	1	Flywheel	66	118732	1	Wire Harness
26	119200	1	Lock Ring	67	113833	1	Left Neck Shield
27	122870	1	Crank	68	113832	1	Right Neck Shield
28	119199	1	Tension Belt	69	107428	6	3/4" Tec Screw
29	123038	1	Tension Pulley	70	101067	1	Power Cord
30	104786	1	Seat Post Bushing	71	106115	1	Reed Switch/Sensor Wire
31	114113	1	Tension Rope	72	012108	1	3/8" x 16 Nut
32	108667	4	Handlebar Bushing	73	114109	2	9/16" Pedal Spacer
33	123785	2	5/16" x 1/2" Screw	74	106832	2	5/16" Flat Washer
34	120761	1	Right Side Shield	75	119466	2	5/8" Handlebar Spacer
35	113792	1	Tension Bracket	76	014132	2	3/8" Flat Washer
36	013250	2	5/16" x 1 3/4" Bolt	77	014117	2	3/8" Star Washer
37	116607	2	Link Arm	#	101324	1	Screwdriver/Wrench
38	112779	2	Pedal Shaft	#	045028	1	Socket Tool
39	100076	1	Small Spring	#	045010	1	Allen Wrench
40	105500	2	Foam Grip	#	016055	4	M-Clip
41	113781	1	Large Spring	#	123278	1	Owner's Manual

Note: "#" indicates a non-illustrated part. Specifications are subject to change without notice. See the back cover of this manual for information about ordering replacement parts.

# EXPLODED DRAWING—Model No. 831.287603

R0396A

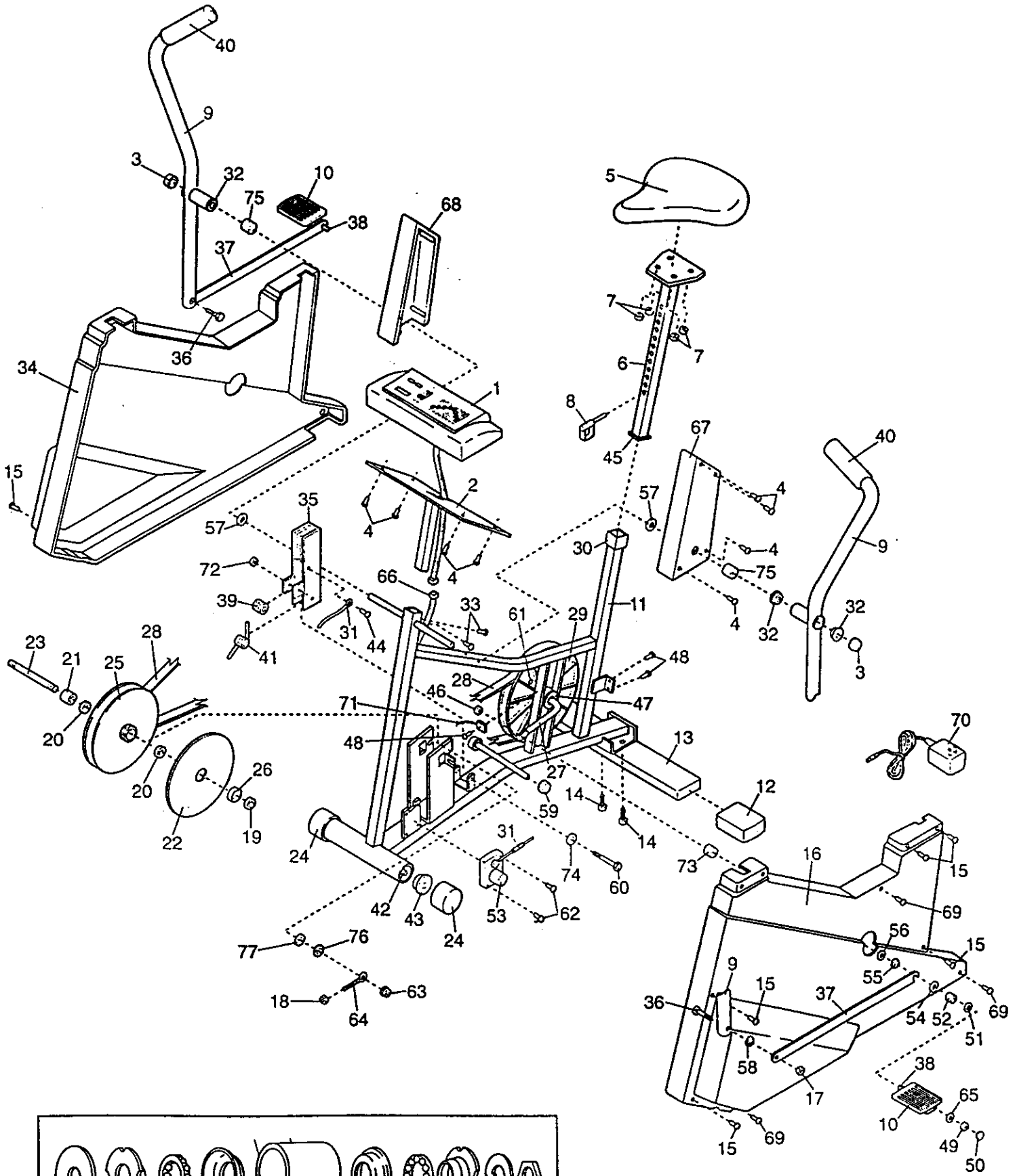

CRANK HARDWARE (47)



Model No. 831.287603

## QUESTIONS?

If you find that:

- you need help assembling or operating the LIFESTYLER C 760
- a part is missing
- or you need to schedule repair service

call our toll-free HELPLINE

**1-800-736-6879**

Monday-Saturday, 7 am-7 pm  
Central Time (excluding holidays)

## REPLACEMENT PARTS

If parts become worn and need to be replaced, call the following toll-free number

**1-800-FON-PART**  
**(1-800-366-7278)**

The model number and serial number of your SEARS LIFESTYLER® C 760 are listed on a decal attached to the frame. See the front cover of this manual to find the location of the decal.

All replacement parts are available for immediate purchase or special order when you visit your nearest SEARS Service Center. To request service or to order parts by telephone, call the toll-free numbers listed at the left.

When requesting help or service, or ordering parts, please be prepared to provide the following information:

- The NAME OF THE PRODUCT (SEARS LIFESTYLER® C 760)
- The MODEL NUMBER OF THE PRODUCT (831.287603)
- The PART NUMBER OF THE PART (see page 10 of this manual)
- The DESCRIPTION OF THE PART (see page 10 of this manual)

## FULL 90 DAY WARRANTY

For 90 days from the date of purchase, if failure occurs due to defect in material or workmanship in this SEARS BIKE EXERCISER, contact the nearest SEARS Service Center throughout the United States and SEARS will repair or replace the BIKE EXERCISER, free of charge.

This warranty does not apply when the BIKE EXERCISER is used commercially or for rental purposes.

This warranty gives you specific legal rights, and you may also have other rights which vary from state to state.

SEARS, ROEBUCK AND CO., DEPT. 817WA, HOFFMAN ESTATES, IL 60179