

WESLO[®] BODYSHOP

ABS • BACK • HIPS • THIGHS

SEARS

Model No. 831.150490

Serial No. _____

The serial number can be found in the location shown below. Write the serial number in the space above.

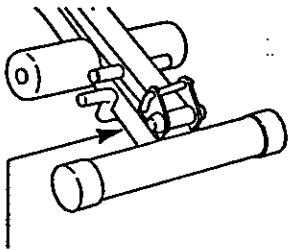

Serial Number Decal

EXERCISE
EQUIPMENT

QUESTIONS

HELPLINE!

LIBRARY 800-736-6879

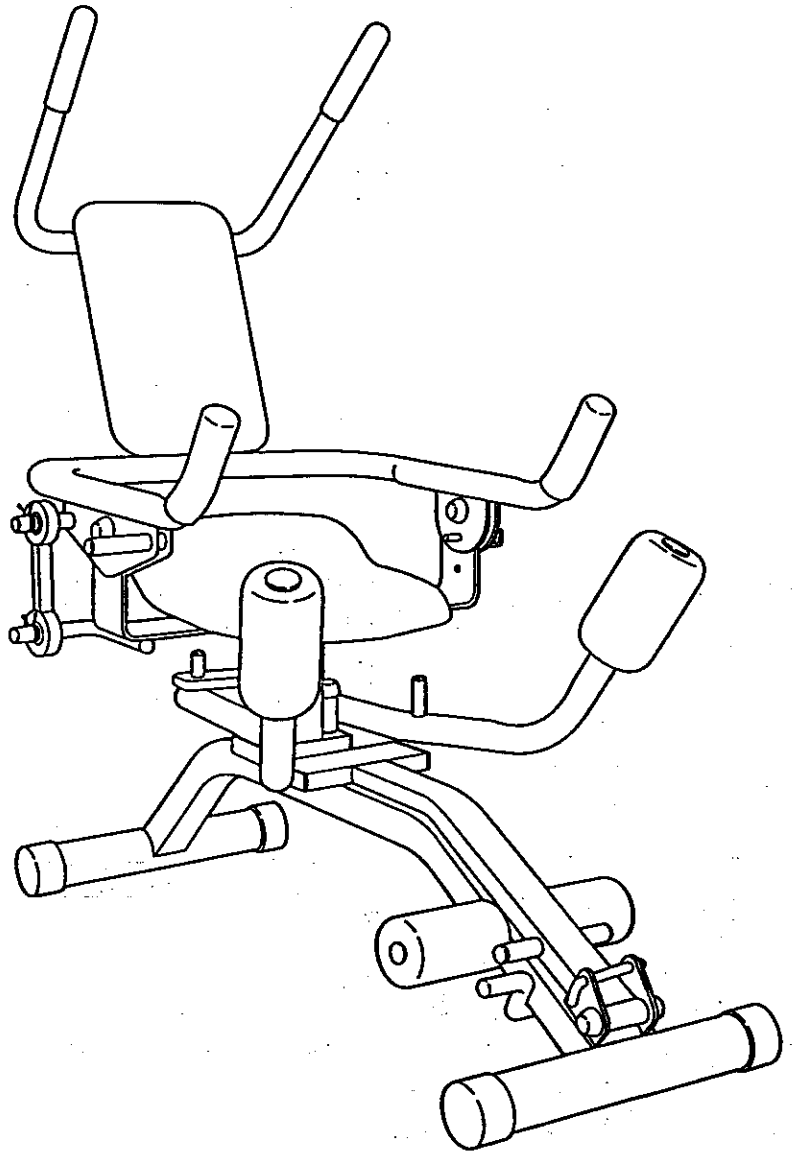

CAUTION!

Read all precautions and instructions in this manual before using this equipment. Save this manual for future reference.

PATENT PENDING

USER'S MANUAL

SEARS, ROEBUCK AND CO., HOFFMAN ESTATES, IL 60179

WESLO[®] BODYSHOP

ABS • BACK • HIPS • THIGHS

TABLE OF CONTENTS

FULL 90 DAY WARRANTY	2
IMPORTANT PRECAUTIONS	3
BEFORE YOU BEGIN	4
ASSEMBLY	5
USING THE BODYSHOP	8
TROUBLE-SHOOTING AND MAINTENANCE	13
PART LIST	14
EXPLODED DRAWING	15
ORDERING REPLACEMENT PARTS	Back Cover

FULL 90 DAY WARRANTY

For 90 days from the date of purchase, if failure occurs due to defect in material or workmanship in this SEARS WEIGHT SYSTEM EXERCISER, contact the nearest SEARS store throughout the United States and SEARS will repair or replace the WEIGHT SYSTEM EXERCISER, free of charge.

This warranty does not apply when the WEIGHT SYSTEM EXERCISER is used commercially or for rental purposes.

This warranty gives you specific legal rights, and you may also have other rights which vary from state to state.

SEARS, ROEBUCK AND CO., DEPT. 817WA, HOFFMAN ESTATES, IL 60179

IMPORTANT PRECAUTIONS

WARNING: To reduce the risk of serious injury, read the following important precautions before using the BODYSHOP.

1. Read all instructions in this manual before using the BODYSHOP.
2. Use the BODYSHOP only on a level surface. Cover the floor beneath the BODYSHOP for protection.
3. Inspect and tighten all parts regularly. Replace any worn parts immediately.
4. Regularly inspect the weight bands for cracks and wear. If the weight bands are damaged, discontinue using them and replace them immediately. (See page 13).
5. When performing exercises that require weight bands, always secure the weight bands with the spring clips.
6. The lock pin should be removed from the pivot arm only to perform ab and oblique exercises and back extension exercises.
7. Keep small children and pets away from the BODYSHOP at all times.
8. Always wear athletic shoes for foot protection when exercising.
9. Keep hands and feet away from moving parts.
10. When using the leg lever, the "L"-pin must be inserted to prevent bodily injury.
11. The BODYSHOP is designed to be used by only one person at a time.
12. If you feel pain or dizziness at any time while exercising, stop immediately and begin cooling down.
13. It is the responsibility of the owner to ensure that all users of the BODYSHOP are adequately informed of all precautions.

WARNING: Before beginning this or any exercise program, consult your physician. This is especially important for persons over the age of 35 or persons with pre-existing health problems. Read all instructions before using. SEARS assumes no responsibility for personal injury or property damage sustained by or through the use of this product.

BEFORE YOU BEGIN

Thank you for selecting the versatile WESLO® BODYSHOP. The BODYSHOP offers a selection of weight stations designed to develop several major muscle groups. Whether your goal is to tone your body, develop greater muscular strength, or improve your cardiovascular system, the BODYSHOP will help you to achieve the specific results you want.

For your benefit, read this manual carefully before using the WESLO® BODYSHOP. If you have additional questions, please call our toll-free HELPLINE at

1-800-736-6879, Monday through Saturday, 7 a.m. until 7 p.m. Central Time (excluding holidays). To help us assist you, please note the product model number and serial number before calling. The model number is 831.150490. The serial number can be found on a decal attached to the BODYSHOP (see the front cover of this manual).

Before reading further, please review the drawing below and familiarize yourself with the parts that are labeled.

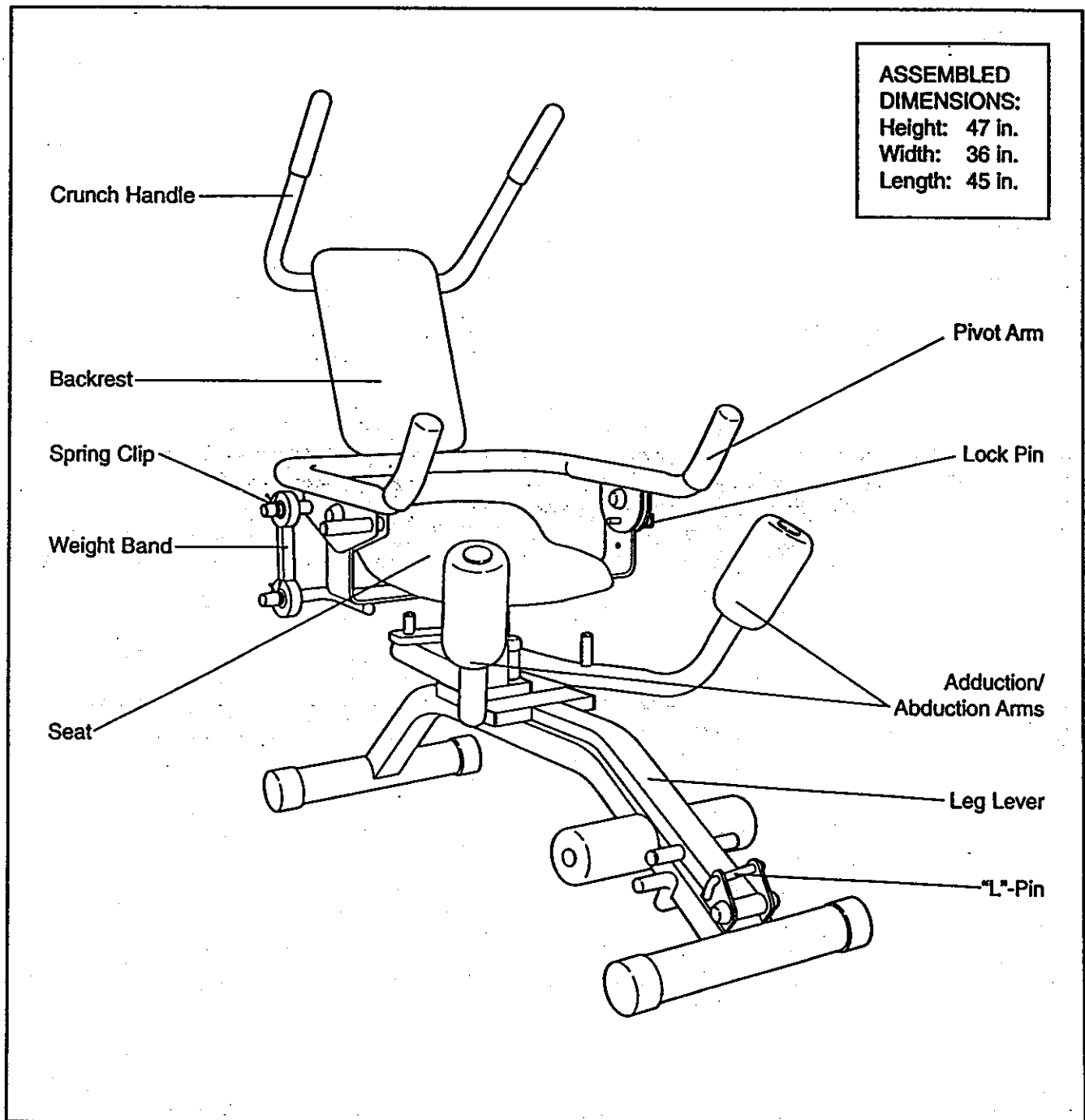



ASSEMBLY

Before beginning assembly, carefully read the following information and instructions:

- Place all parts of the BODYSHOP in a cleared area and remove the packing materials; do not dispose of the packing materials until assembly is completed.
- Tighten all parts as you assemble them, unless instructed to do otherwise.
- For help identifying the small parts used in assembly, use the PART IDENTIFICATION CHART below.
- As you assemble the BODYSHOP, be sure that all parts are oriented as shown in the drawings.

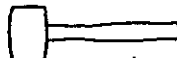
THE FOLLOWING TOOLS (NOT INCLUDED) ARE REQUIRED FOR ASSEMBLY:

- Two (2) adjustable wrenches 
- One (1) rubber mallet 
- The included allen wrench 
- The included lubricant and a small amount of warm soapy water will also be needed for assembly.

Assembly will be more convenient if you have the following tools: A socket set, a set of open-end or closed-end wrenches, or a set of ratchet wrenches.

PART IDENTIFICATION CHART

This chart is provided to help you identify the small parts used in assembly. Important: Some parts may have been pre-assembled for shipping purposes. If you cannot find a part in the parts packet, check

to see if it has been pre-assembled. The number in parenthesis below each part refers to the key number of the part. The second number refers to the quantity needed for assembly.

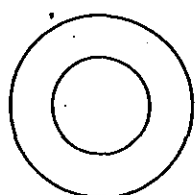

1/2" Bushing (31)-2

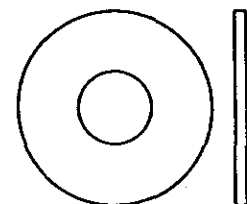

3/8" Washer (30)-2



1/4" x 1" Screw (2)-4

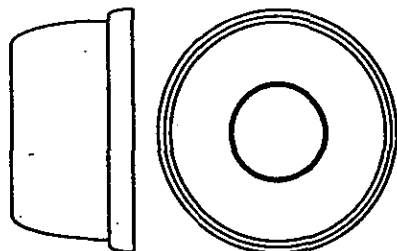

1/2" Axle Cap (7)-6



1 3/4" Pin (25)-2

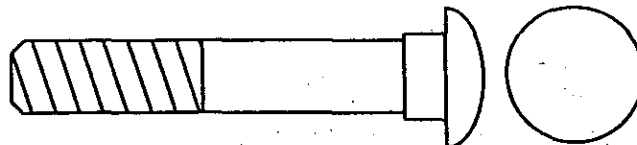

3/8" x 2 1/4" Carriage Bolt (33)-2



1/4" Nylon Locknut (1)-4



3/8" Nylon Locknut (34)-2

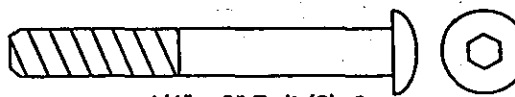

1/4" x 2" Bolt (3)-2

1. Before beginning assembly, carefully read the information on the previous page.

Remove the Left Arm (13) and Right Arm (14) from the Base (4). Note: The Left and Right Arms are placed upside down and on the opposite sides of the Base for shipping.

Lubricate the indicated posts on the Base (4). Slide the Left Arm (13) onto the post on the left side of the Base. Tap a 1/2" Axle Cap (7) onto the post. Attach the Right Arm (14) to the post on the right side with a 1/2" Axle Cap (7).

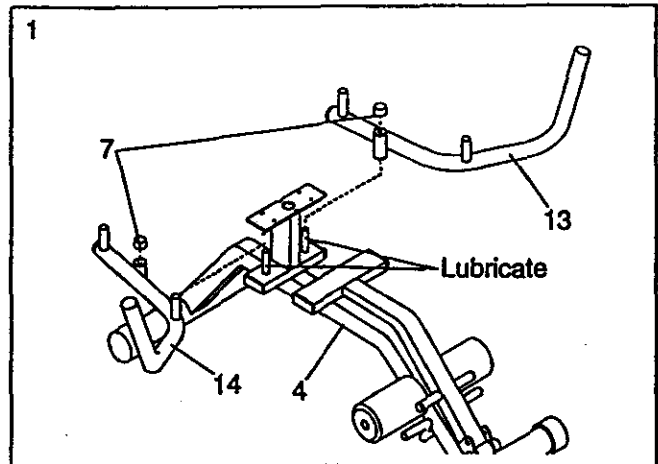

2. Using the included allen wrench, attach the Seat Frame (11) to the Base (4) with four 1/4" x 1" Screws (2) and four 1/4" Nylon Locknuts (1). Be sure that the indicated pin is on the right side of the Base.

Wet the ends of the Right and Left Arms (13, 14) with soapy water. Slide a Large Pad (35) onto each Arm.

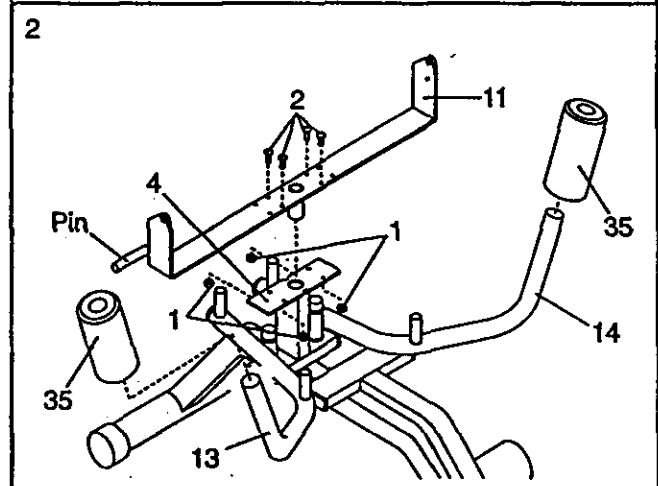

3. Insert the Seat Bushing (12) into the hole in the center of the Seat Frame (11).

Insert the post on the Pivot Plate (39) which is attached to the underside of the Seat (22) into the Seat Bushing (12).

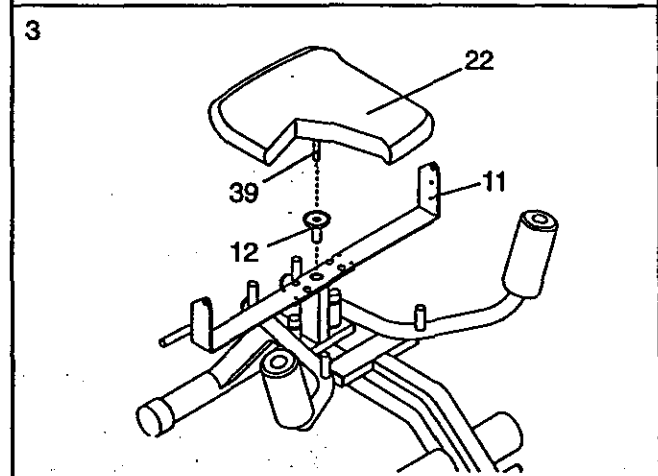

4. Press a 1/2" Bushing (31) into each side of the Seat Frame (11).

Lubricate both 1 3/4" Pins (25). Attach each side of the Pivot Arm (16) to the Seat Frame (11) with a 1 3/4" Pin and two 1/2" Axle Caps (7). See the inset drawing for the proper orientation of all parts.

Insert the Lock Pin (24) into the indicated hole in the left side of the Pivot Arm (16) and the left side of the Seat Frame (11).

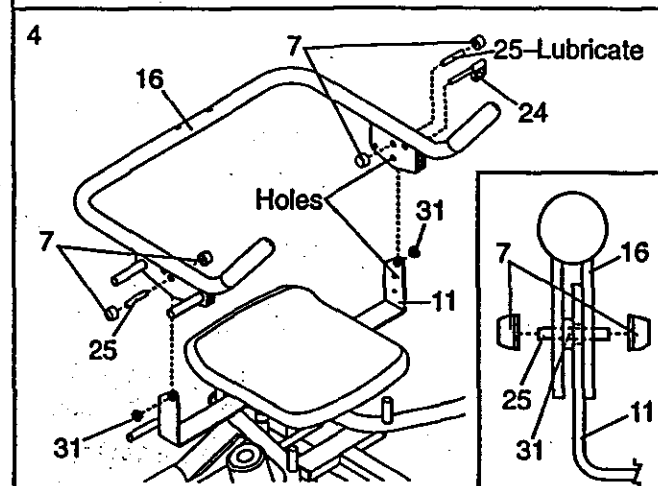

5. Attach the Backrest Frame (19) to the Pivot Arm (16) with two 3/8" x 2 1/4" Carriage Bolts (33), two 3/8" Washers (30), and two 3/8" Nylon Locknuts (34).

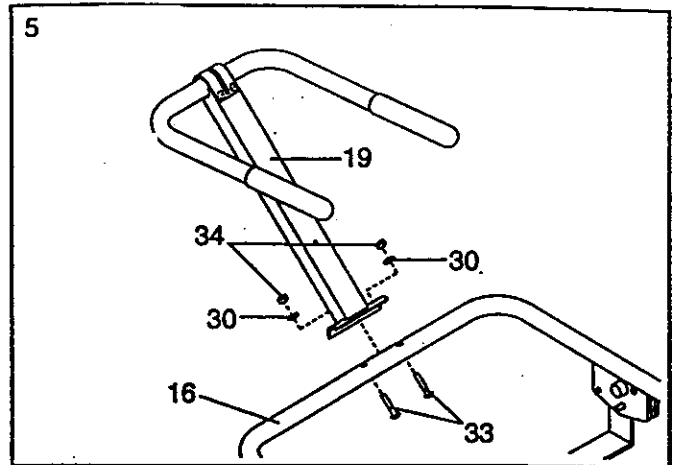

6. Using the included allen wrench, attach the Backrest (23) to the Backrest Frame (19) with two 1/4" x 2" Bolts (3).

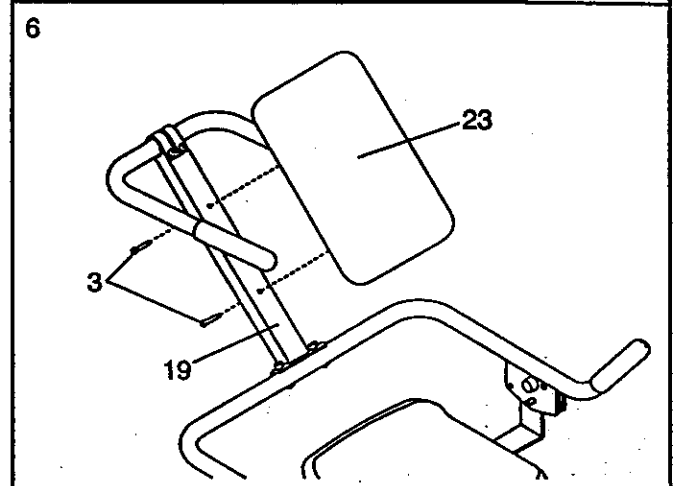

USING THE BODYSHOP

The BODYSHOP is a tool, and learning to use it properly is essential for the success of your exercise program. Read this manual carefully before beginning your exercise program. Remember, the information in this section is general in nature—for detailed information about exercise, consult your physician or obtain a reputable book about exercise.

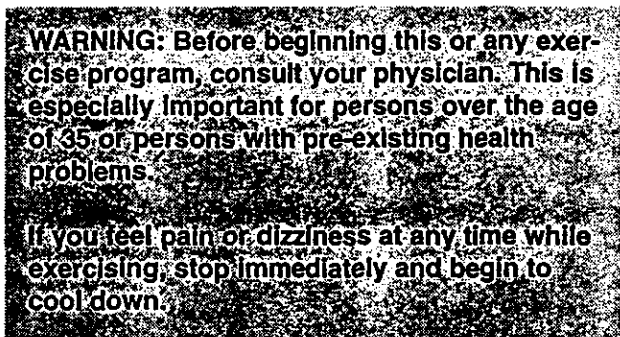

THE FOUR BASIC TYPES OF WORKOUTS

Muscle Building

In order to increase the size and strength of your muscles, you must push your muscles to a high percentage of their capacity. You must also progressively increase the intensity of your exercise so that your muscles will continue to adapt and grow. Each individual exercise can be tailored to the proper intensity level by changing the weight bands, or by changing the number of repetitions or sets performed. (A "repetition" is one complete cycle of an exercise, such as one sit-up. A "set" is a series of repetitions performed consecutively.)

The proper weight bands to use for each exercise depends upon the individual user. It is up to you to gauge your limits. Select the resistance level that you think is right for you. Begin with 3 sets of 8 repetitions for each exercise that you perform. Rest for 3 minutes after each set. When you can complete 3 sets of 12 repetitions without difficulty, increase the resistance level.

Toning

To tone your muscles, you must push your muscles to a moderate percentage of their capacity. Select a moderate resistance level and increase the number of repetitions in each set. Complete as many sets of 15 to 20 repetitions as possible without discomfort. Rest for 1 minute after each set. Work your muscles by completing more sets rather than by using high amounts of resistance.

Weight Loss

To lose weight, use a low level of resistance and increase the number of repetitions in each set. Exercise for 20 to 30 minutes, resting for a maximum of 30 seconds between sets.

Cross Training

In the pursuit of a complete and well-balanced fitness program, many have found that cross training is the answer. We recommend that on Monday, Wednesday and Friday, you plan weight training workouts. On Tuesday and Thursday, plan 20 to 30 minutes of aerobic exercise, such as cycling, running or swimming.

Rest from both weight training and aerobic exercise for at least one full day each week to give your body time to regenerate. By combining weight training with aerobic exercise, you can reshape and strengthen your body, plus develop a stronger heart and lungs.

PERSONALIZING YOUR EXERCISE PROGRAM

We have not specified an exact length of time for each workout, or a specific number of repetitions or sets for each exercise. It is important to avoid overdoing it during the first few months of your exercise program, and to progress at your own pace.

Remember that adequate rest and a proper diet are also important.

WARMING UP

Begin each workout with 5 to 10 minutes of light stretching and exercise to warm up. Warming up prepares your body for exercise by increasing circulation, raising your body temperature and delivering more oxygen to your muscles.

WORKING OUT

Using the BODYSHOP is an effective way to develop your legs, lower back, and abdomen. This section details the seven exercises that you can perform using the BODYSHOP. To give balance and variety to your workouts, your workout should also include other types of exercises that focus on your upper body and arms.

Schedule your workouts for the time of day when your energy level is the highest. Each workout should be followed by at least one day of rest. Once you find the schedule that is right for you, stick with it.

EXERCISE FORM

In order to obtain the greatest benefits from exercising, proper form is essential. Maintaining proper form means moving through the full range of motion for each exercise, and moving only the appropriate parts of the body. Exercising in an uncontrolled manner will leave you feeling exhausted.

On pages 9 through 12 of this manual, you will find illustrations demonstrating how to set up the BODYSHOP for each exercise and photographs showing the correct form for each exercise. A description of each exercise is also provided, along with a list of the muscles affected.

The repetitions in each set should be performed smoothly and without pausing. The exertion stage of each repetition should last about half as long as the return stage. Proper breathing is important. Exhale during the exertion stage of each repetition and inhale during the return stroke; never hold your breath. Rest for 3 minutes after each set if you are doing a muscle building workout, 1 minute after each set if you are

doing a toning workout, and 30 seconds after each set if you are doing a weight loss workout.

COOLING DOWN

Finish each workout with 5 to 10 minutes of stretching. Include stretches for both your arms and legs. Move slowly as you stretch—do not bounce. Ease into each stretch gradually and go only as far as you can without strain. Stretching at the end of each workout is effective for increasing flexibility and helping to prevent soreness and other post-workout problems.

STAYING MOTIVATED

For motivation, keep a record of each workout. Write the date, exercises performed, resistance selected, and numbers of repetitions and sets completed. Record your weight and key body measurements each month.

The key to success is to make exercise a regular and enjoyable part of your everyday life.

SET-UP AND EXERCISE FORM

1

HIP ABDUCTION

Bring the Right and Left Arms (13, 14) together, until you can slide the desired number of Weight Bands (27, 28, or 29) onto the indicated pins. Secure the Weight Band(s) with Spring Clips (32). Note: The seat is shown removed for illustration purposes.

Be sure the Pivot Arm (16) is secured with the Lock Pin (24).

Place the desired amount of resistance on the arms (see above). Sit on the seat. Position your legs against the insides of the arms as shown. Press the arms out as far as possible. Return to the starting position.

Muscles affected: abductor, gluteus medius

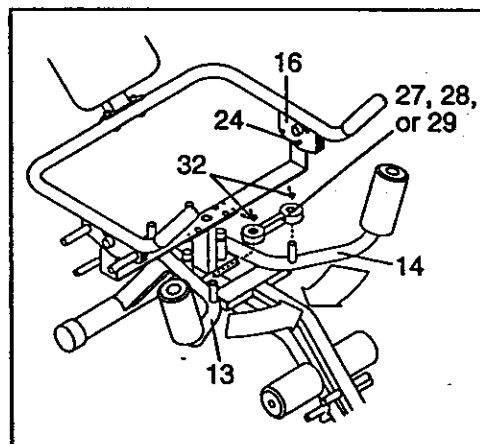

2

HIP ADDUCTION

Bring the ends of the Right and Left Arms (13, 14) together, until you can slide the desired number of Weight Bands (27, 28, or 29) onto the indicated pins. Secure the Weight Band(s) with Spring Clips (32). Note: The seat is shown removed for illustration purposes.

Be sure the Pivot Arm (16) is secured with the Lock Pin (24).

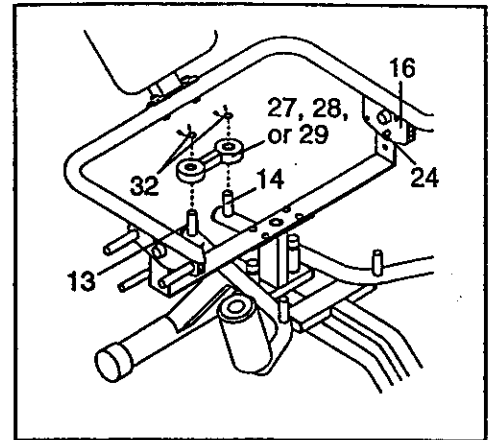

Place the desired amount of resistance on the arms (see above). Sit on the seat. Position your legs against the outsides of the arms as shown. Bring your legs together. Return to the starting position.

Muscles affected: abductor, gluteus medius



3

BACK EXTENSION

Remove the Lock Pin (24) from the Pivot Arm (16).

Tilt the Pivot Arm (16) forward, until you can slide the desired number of Weight Bands (27, 28, or 29) onto the indicated pins. Secure the Weight Band(s) with Spring Clips (32).

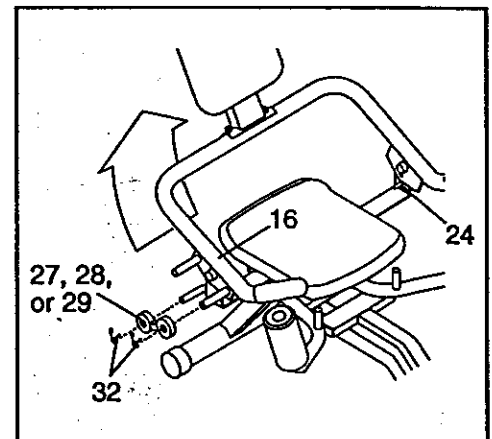

Sit on the seat and hold the handles as shown. Keep your back straight and bend back at the waist. Return to the starting position.

Muscles affected: hip extensors



4

AB CRUNCH

Remove the Lock Pin (24) from the Pivot Arm (16).

Slide the desired number of Weight Bands (27, 28, or 29) onto the indicated pins. Secure the Weight Bands with Spring Clips (32).

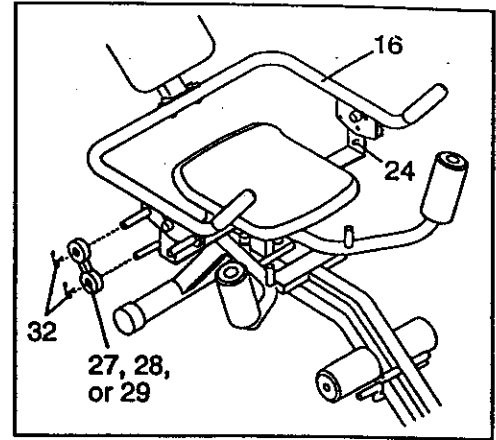

Sit on the seat and hold the handles as shown. Keep your back straight and slowly bend forward at the waist. Return to the starting position.

Muscles affected: rectus abdominus, upper abdominals



5

OBLIQUE CRUNCH

Remove the Lock Pin (24) from the Pivot Arm (16).

Slide the desired number of Weight Bands (27, 28, or 29) onto the indicated pins. Secure the Weight Bands with Spring Clips (32).

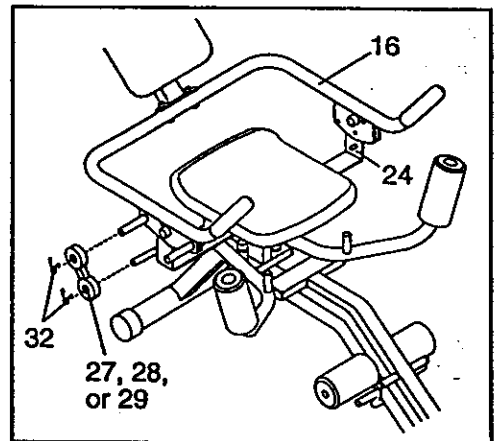

Sit on the seat and turn your body to the right or to the left. Twist your upper body and hold the handles as shown. Keep your back straight and slowly bend forward at the waist. Return to the starting position. Alternate sides after each repetition.

Muscles affected: rectus abdominus, upper abdominals, obliques



9**LEG PRESS**

Remove the "L"-Pin (38) from the bracket on the Base (4). Lift the Leg Lever (18) and re-insert the "L"-Pin into the bracket. Lower the Leg Lever onto the "L"-Pin. Slide the desired number of Weight Bands (27, 28, or 29) onto the indicated pins on one or both sides of the leg lever. Secure the Weight Bands with Spring Clips (32).

Be sure the Pivot Arm (16) is secured with the Lock Pin (24).

When the Leg Lever is not in use, remove the Weight Bands (27, 28, or 29) and "L"-Pin (38). Lay the Leg Lever on the Base (4) and re-insert the "L"-Pin (38).

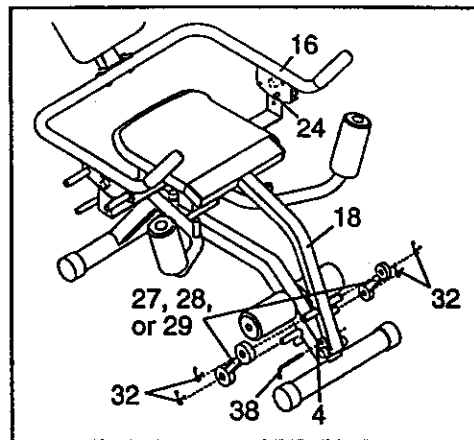

Sit on the seat and place your feet on the leg lever as shown. Press forward until your legs are fully extended. Return to the starting position.

Muscles affected: quadriceps

**7****HIP TWIST**

Be sure that all Weight Bands have been removed from the Right and Left Arms (13, 14) and from the Leg Lever (18). Be sure the Pivot Arm (16) is secured with the Lock Pin (24).

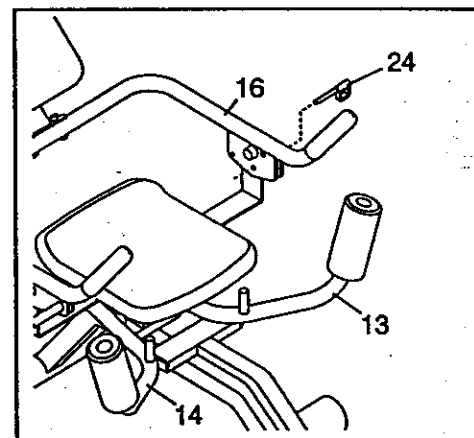

Sit on the seat, with your legs extended, and hold the handles as shown. Hold your upper body straight. Rotate on the seat, twisting at the waist. Twist ten times.

Muscles affected: hip flexors, gluteus medius



TROUBLE-SHOOTING AND MAINTENANCE

Inspect and tighten all parts of the BODYSHOP often. Replace any worn parts immediately.

Regularly inspect the Weight Bands (27, 28, or 29) for cracks and wear. To inspect the Weight Bands, bend the Weight Band several different directions (see the drawing to the right). If there are any cracks forming, they will appear when the Weight Band is bent in this manner. If the Weight Bands are damaged, discontinue using them and replace them immediately.

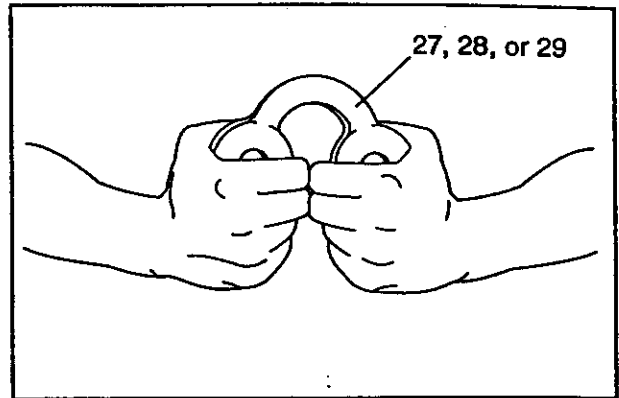

Lubricate moving parts regularly. The BODYSHOP can be cleaned using a damp cloth and mild non-abrasive detergent. Do not use solvents.

To order replacement parts, see the back cover of this manual.

PART LIST—Model No. 831.150490

R0995A

Key No.	Part No.	Qty.	Description	Key No.	Part No.	Qty.	Description
1	012139	6	1/4" Nylon Locknut	21	126097	1	Slotted "U"-Bracket
2	013492	8	1/4" x 1" Screw	22	125986	1	Seat <i>127602</i>
3	013523	4	1/4" x 2" Bolt	23	125985	1	Backrest <i>127592</i>
4	NSP	1	Base	24	126090	1	Lock Pin
5	126166	4	3" x 1" Endcap	25	125397	2	1 3/4" Pin
6	109416	4	2" Round Endcap	26	109470	1	3 1/2" Pin
7	103903	8	1/2" Axle Cap	27	105741	2	#25 Weight Band
8	125979	6	3/4" Endcap	28	105739	1	#10 Weight Band
9	115998	4	1 1/2" Endcap	29	105736	1	#5 Weight Band
10	124546	6	1/2" Bushing	30	014086	2	3/8" Washer
11	125876	1	Seat Frame	31	103677	2	1/2" Bushing
12	125973	1	Seat Bushing	32	100092	4	Spring Clip
13	125962	1	Left Arm	33	121568	2	3/8" x 2 1/4" Carriage Bolt
14	125888	1	Right Arm	34	012025	2	3/8" Nylon Locknut
15	103805	2	Small Pad	35	125983	2	Large Pad
16	126168	1	Pivot Arm	36	104899	2	6" Foam Grip
17	105500	2	1 1/4" Foam Grip	37	126709	2	Foam Foot Pad
18	126712	1	Leg Lever	38	126708	1	"L"-Pin
19	125965	1	Backrest Frame	39	127156	1	Pivot Plate
20	126092	1	Crunch Handle	#	125631	1	User's Manual

Note: "#" indicates a non-illustrated part. Specifications are subject to change without notice. See the back cover for information about ordering replacement parts.

EXPLODED DRAWING—Model No. 831.150490

R0995A

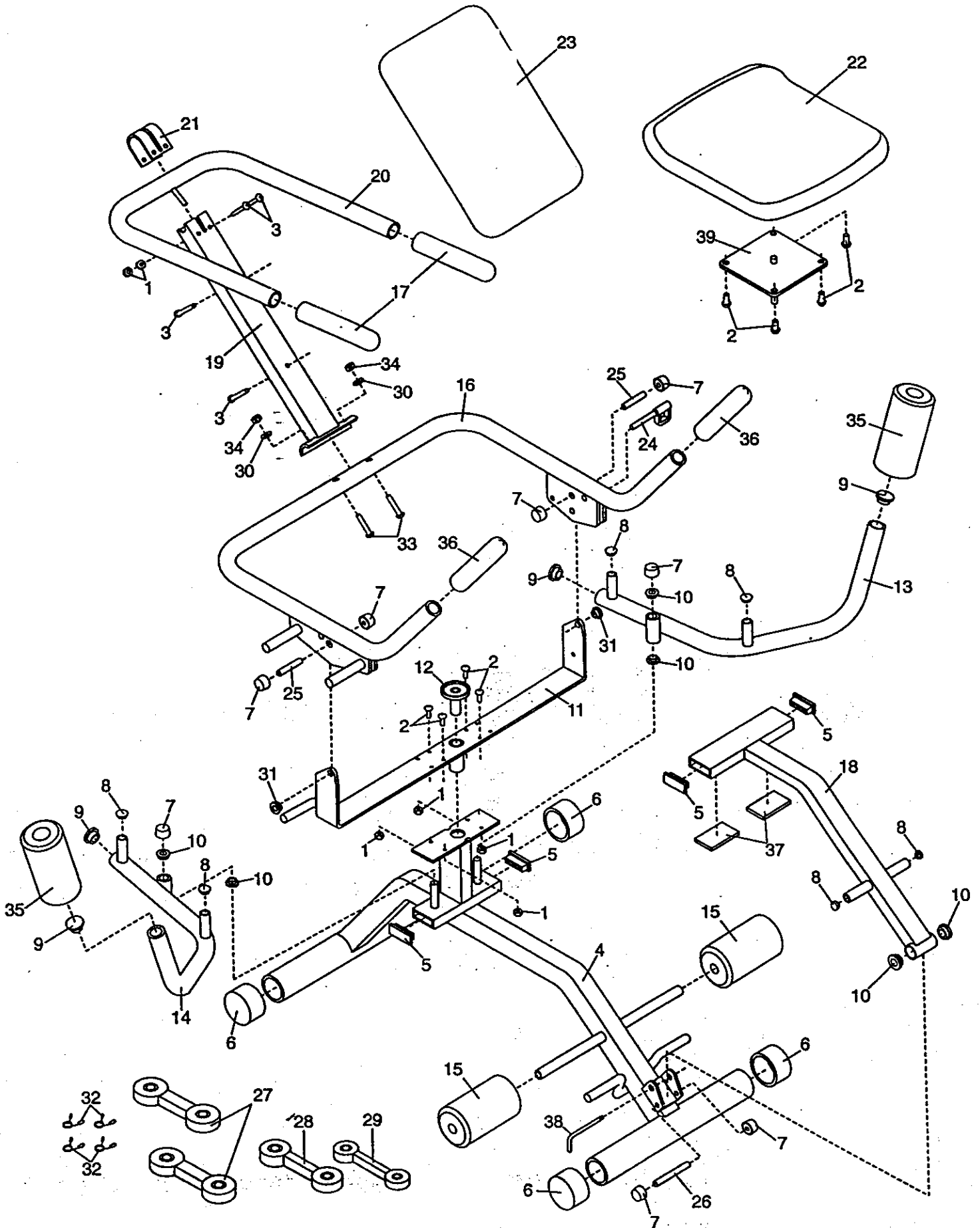



Model No. 831.150490

QUESTIONS?

If you find that:

- you need help assembling or operating the WESLO® BODYSHOP
- a part is missing
- or you need to schedule repair service

call our toll-free HELPLINE

1-800-736-6879

Monday–Saturday, 7 am–7 pm
Central Time (excluding holidays)

REPLACEMENT PARTS

If parts become worn and need to be replaced, call the following toll-free number

1-800-FON-PART
(1-800-366-7278)

The model number and serial number of your WESLO® BODYSHOP are listed on a decal attached to the frame. See the front cover of this manual to find the location of the decal.

All replacement parts are available for immediate purchase or special order when you visit your nearest SEARS Service Center. To request service or to order parts by telephone, call the toll-free numbers listed at the left.

When requesting help or service, or ordering parts, please be prepared to provide the following information:

- The NAME OF THE PRODUCT (WESLO® BODYSHOP).
- The MODEL NUMBER OF THE PRODUCT (831.150490).
- The PART NUMBER OF THE PART (see the PART LIST on page 14 of this manual).
- The DESCRIPTION OF THE PART (see the PART LIST on page 14 of this manual).

SEARS, ROEBUCK AND CO., HOFFMAN ESTATES, IL 60179