

# Lifestyler

# EXPANSE™ 750

## SEARS

Model No. 831.297492

Serial No. \_\_\_\_\_

The serial number can be found in the location shown below. Write the serial number in the space above.

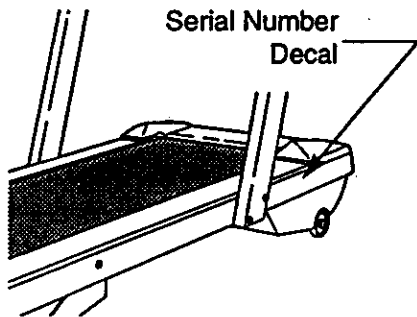

EXERCISE  
EQUIPMENT

QUESTIONS

HELPLINE!

1-800-736-6879

### CAUTION

Read all precautions and instructions in this manual before using this equipment. Keep this manual for future reference.

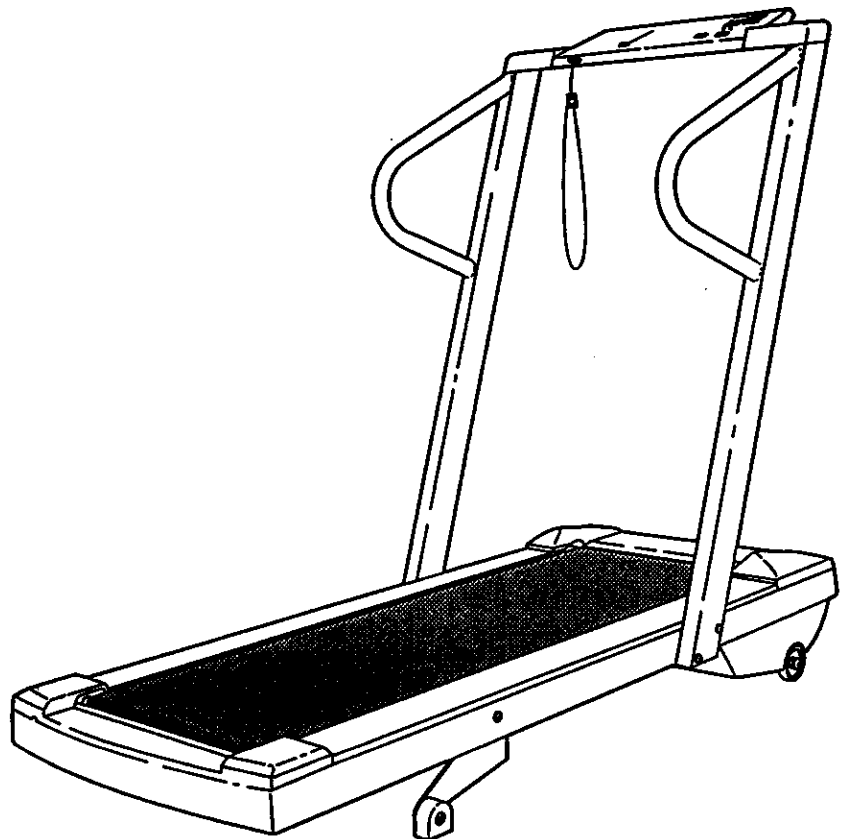

## USER'S MANUAL

SEARS, ROEBUCK AND CO., HOFFMAN ESTATES, IL 60179

## **FULL 90 DAY WARRANTY**

For 90 days from the date of purchase, if failure occurs due to defect in material or workmanship in this SEARS TREADMILL EXERCISER, contact the nearest SEARS Service Center throughout the United States and SEARS will repair or replace the TREADMILL EXERCISER, free of charge.

This warranty does not apply when the TREADMILL EXERCISER is used commercially or for rental purposes.

This warranty gives you specific legal rights, and you may also have other rights which vary from state to state.

**SEARS, ROEBUCK AND CO., DEPT. 817WA, HOFFMAN ESTATES, IL 60179**

# *Lifestyler*

# EXPANSE™ 750

---

## TABLE OF CONTENTS

FULL 90 DAY WARRANTY .....	2
IMPORTANT PRECAUTIONS .....	4
BEFORE YOU BEGIN .....	5
ASSEMBLY .....	6
OPERATION AND ADJUSTMENT .....	7
TROUBLE-SHOOTING AND STORAGE .....	11
CONDITIONING GUIDELINES .....	13
ORDERING REPLACEMENT PARTS .....	Back Cover

Note: An EXPLODED DRAWING and a PART LIST are attached to the center of this manual. Save the EXPLODED DRAWING and PART LIST for future reference.

**▲WARNING:** Before beginning this or any exercise program, consult your physician. This is especially important for persons over the age of 35 or persons with pre-existing health problems. Read all instructions before using. SEARS assumes no responsibility for personal injury or property damage sustained by or through the use of this product.

# IMPORTANT PRECAUTIONS

**⚠ WARNING:** To reduce the risk of burns, fire, electric shock or injury to persons, read the following important precautions and information before operating the treadmill.

1. It is the responsibility of the owner to ensure that all users of this treadmill are adequately informed of all warnings and precautions.
2. Use the treadmill only as described in this manual.
3. Place the treadmill on a level surface, with at least 8 feet of clearance behind it. To protect the floor or carpet from damage, place a mat under the treadmill.
4. Do not place the treadmill near water, outdoors, or on a surface that blocks any air openings.
5. Do not operate the treadmill where aerosol products are used or where oxygen is being administered.
6. Keep small children and pets away from the treadmill at all times.
7. The treadmill should be used only by persons weighing 250 pounds or less.
8. Never allow more than one person on the treadmill at a time.
9. When connecting the power cord (see HOW TO PLUG IN THE POWER CORD on page 7), plug the power cord directly into a grounded circuit capable of carrying 12 or more amps. No other appliance should be on the same circuit. Keep the power cord away from heated surfaces.
10. If an extension cord is needed, use a 14-gauge general-purpose cord of five feet or less in length with a three-wire conductor.
11. Never move the walking belt while the power is turned off. Do not operate the treadmill if the power cord or plug is damaged, or if the treadmill is not working properly. (See BEFORE YOU BEGIN on page 5 if the treadmill is not working properly.)
12. Wear appropriate exercise attire when using the treadmill. Do not wear loose clothing that could become caught in the treadmill. Athletic support clothes are recommended for both men and women. Always wear athletic shoes. Never use the treadmill with bare feet, wearing only stockings, or in sandals.
13. Never start the treadmill while you are standing on the walking belt. Always hold the handrails while using the treadmill.
14. The treadmill is capable of high speeds. Adjust the speed in small increments to avoid sudden jumps in speed.
15. To reduce the possibility of the treadmill overheating, do not operate the treadmill continuously for longer than 1 hour.
16. Never leave the treadmill unattended while it is running. Always remove the key when the treadmill is not in use. Always remove the key and move the on/off switch to the "off" position when the treadmill is not in use. (See the drawing on page 5 for the location of the on/off switch.)
17. Never insert any object into any opening.
18. Always unplug the power cord before performing the maintenance and adjustment procedures described in this manual. Never remove the motor hood unless instructed to do so by an authorized service representative. Servicing other than the procedures in this manual should be performed by an authorized service representative only.

**SAVE THESE INSTRUCTIONS**

# BEFORE YOU BEGIN

Thank you for selecting the SEARS LIFESTYLER® EXPANSE 750 treadmill. The EXPANSE 750 treadmill blends advanced technology with innovative design to let you enjoy an excellent form of cardiovascular exercise in the convenience and privacy of your home.

For your benefit, read this manual carefully before using the treadmill. If you have additional questions, please call our toll-free HELPLINE at 1-800-736-6879, Monday through Saturday, 7 a.m. until 7 p.m. Central

Time (excluding holidays). To help us assist you, please note the product model number and serial number before calling. The model number of the treadmill is 831.297492. The serial number can be found on a decal attached to the treadmill (see the front cover of this manual for the location).

Before reading further, please review the drawing below and familiarize yourself with the parts that are labeled.

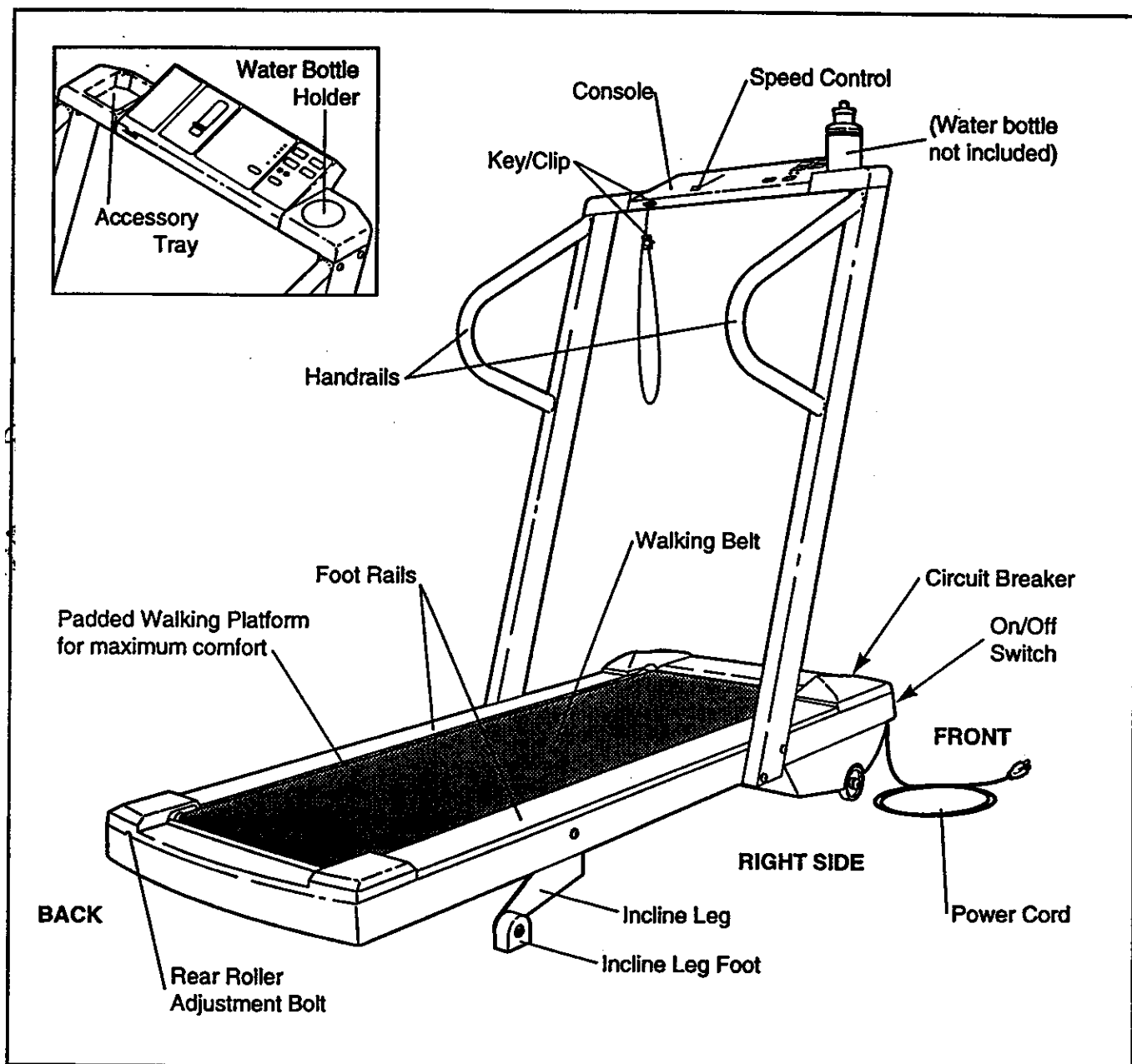

# ASSEMBLY

Assembly requires two people. Set the treadmill in a cleared area and remove all packing materials. Do not dispose of the packing materials until assembly is completed. Refer to the drawings below to identify the small parts used in assembly. Assembly can be completed using the included 7/32" allen wrench .

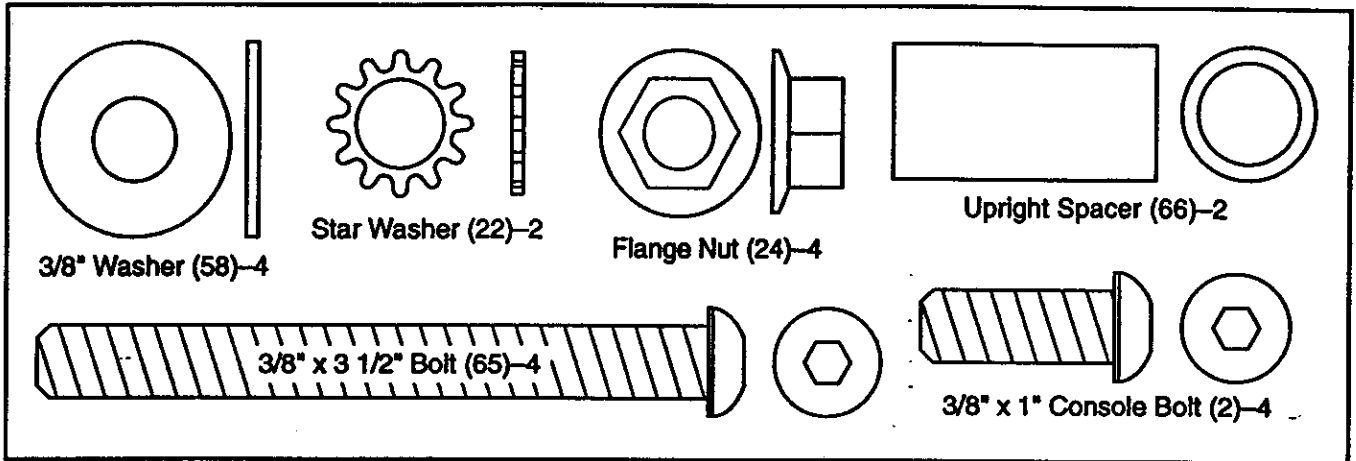

1. Hold an Upright Spacer (66) inside the lower end of the right Upright (11). (Note: Refer to the inset drawing to identify the right Upright. The Upright Plugs [88] must be on the indicated side.) Insert a 3/8" x 3 1/2" Bolt (65), with a 3/8" Washer (58), into the lower hole in the Upright and through the Upright Spacer. Slide a Star Washer (22) onto the Bolt. Insert a 3/8" x 3 1/2" Bolt (65), with a 3/8" Washer (58), into the other hole near the lower end of the Upright.

Insert the 3/8" x 3 1/2" Bolts (65) into the indicated holes in the right side of the Frame (57). Reach under the Frame and loosely thread a Flange Nut (24) onto each Bolt.

Attach the left Upright (11) to the left side of the Frame (57) in the same manner.

2. Hold the Console (7) near the upper end of the right Upright (11). Feed the Long Wire Harness (12) down into the Upright, until the Long Wire Harness extends from the lower end of the Upright. Note: If the end of the Long Wire Harness gets caught in the Upright, it may be helpful to turn the 3/8" x 3 1/2" Bolts (65) back and forth. Be careful not to damage the Long Wire Harness. Make sure that the Cable Looms (13) are in the upper and lower ends of the Upright.

If there are cable ties in the holes in the Console Plate (4), cut them. Insert the Console Plate into the right Upright (11) and the left Upright (not shown). Attach each side of the Console Plate with two 3/8" x 1" Console Bolts (2).

Tighten the four 3/8" x 3 1/2" Bolts (65).

Plug the lower end of the Long Wire Harness (12) into the Short Wire Harness (51). The small latch on the Long Wire Harness should snap onto the Short Wire Harness (see the inset drawing). If the Wire Harnesses do not fit together easily, turn them; do not force the Wire Harnesses together. Slide the end of the Cable Loom (13) against the end of the Long Wire Harness. Be careful not to damage the Wire Harnesses.

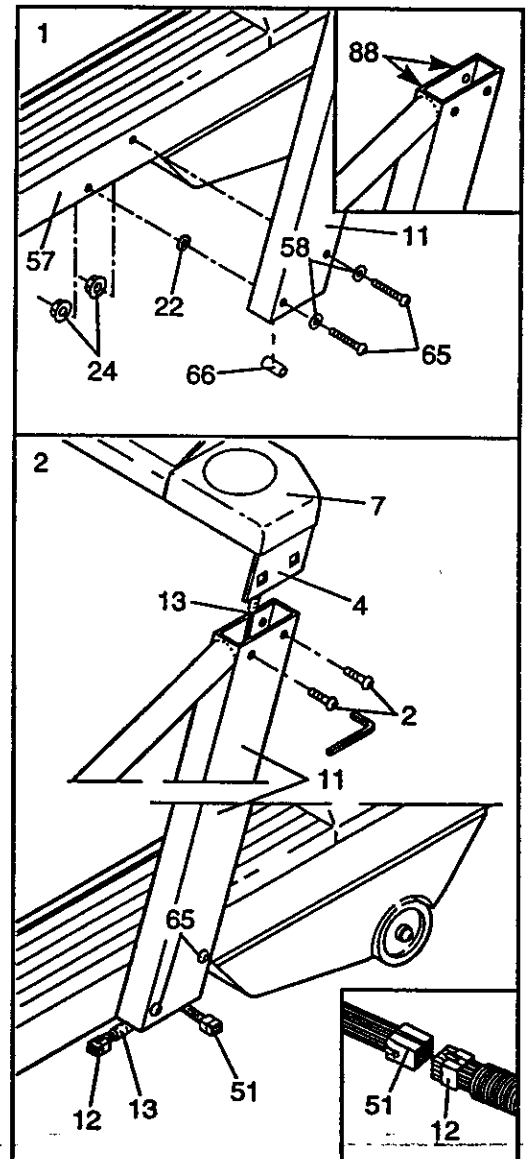

- Remove the paper backing from the Wrench Clip (30). Press the Wrench Clip onto the Frame (57) in the indicated location. Press the 3/16" Allen Wrench (77) into the Wrench Clip.

Make sure that the two Incline Leg Feet (72) are turned so the flat sides are at the bottom.

Make sure that all parts are tightened before using the treadmill.

**Note:** Cover the floor beneath the treadmill to protect the floor or carpet.

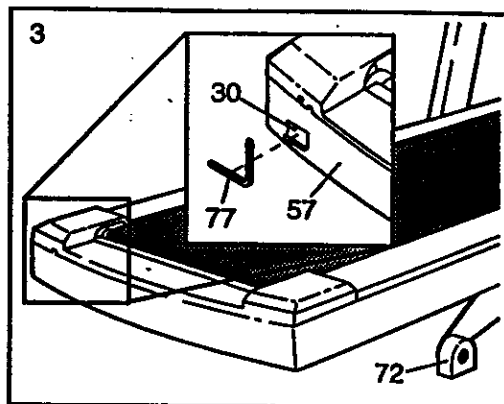

## OPERATION AND ADJUSTMENT

### THE PERFORMANT LUBE™ WALKING BELT

Your treadmill features a low-maintenance walking belt coated with PERFORMANT LUBE™, a high-performance lubricant. During the first few hours of use, a small amount of white powder may accumulate on the foot rails and the walking platform. The white powder is high-performance lubricant from the walking belt. Never apply silicone spray or other substances to the walking belt or the walking platform. They will deteriorate the walking belt and cause excessive wear.

### HOW TO PLUG IN THE POWER CORD

This product must be grounded. If it should malfunction or break down, grounding provides a path of least resistance for electric current to reduce the risk of electric shock. This product is equipped with a cord having an equipment-grounding conductor and a grounding plug. Plug the power cord into an appropriate outlet that is properly installed and grounded in accordance with all local codes and ordinances.

**⚠ DANGER:** Improper connection of the equipment-grounding conductor can result in an increased risk of electric shock. Check with a qualified electrician or serviceman if you are in doubt as to whether the product is properly grounded. Do not modify the plug provided with the product—if it will not fit the outlet, have a proper outlet installed by a qualified electrician.

This product is for use on a nominal 120-volt circuit, and has a grounding plug that looks like the plug illustrated in drawing 1 on this page. A temporary adapter that looks like the adapter illustrated in drawing 2 may be used to connect this plug to a 2-pole receptacle as shown in drawing 2 if a properly grounded outlet is not available.

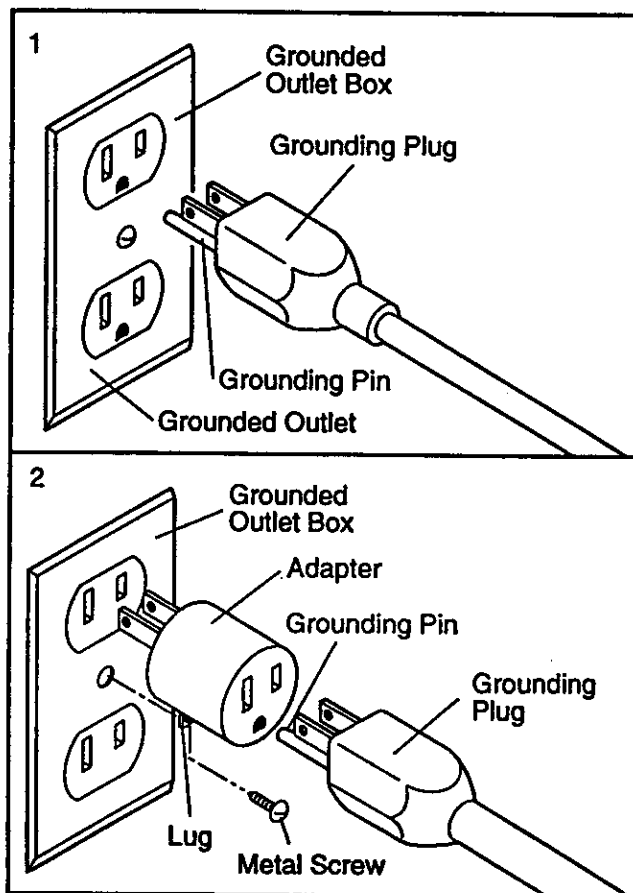

The temporary adapter should be used only until a properly grounded outlet (drawing 1) can be installed by a qualified electrician.

The green-colored rigid ear, lug, or the like extending from the adapter must be connected to a permanent ground such as a properly grounded outlet box cover. Whenever the adapter is used it must be held in place by a metal screw. Some 2-pole receptacle outlet box covers are not grounded. Contact a qualified electrician to determine if the outlet box cover is grounded before using an adapter.

# DIAGRAM OF THE CONSOLE

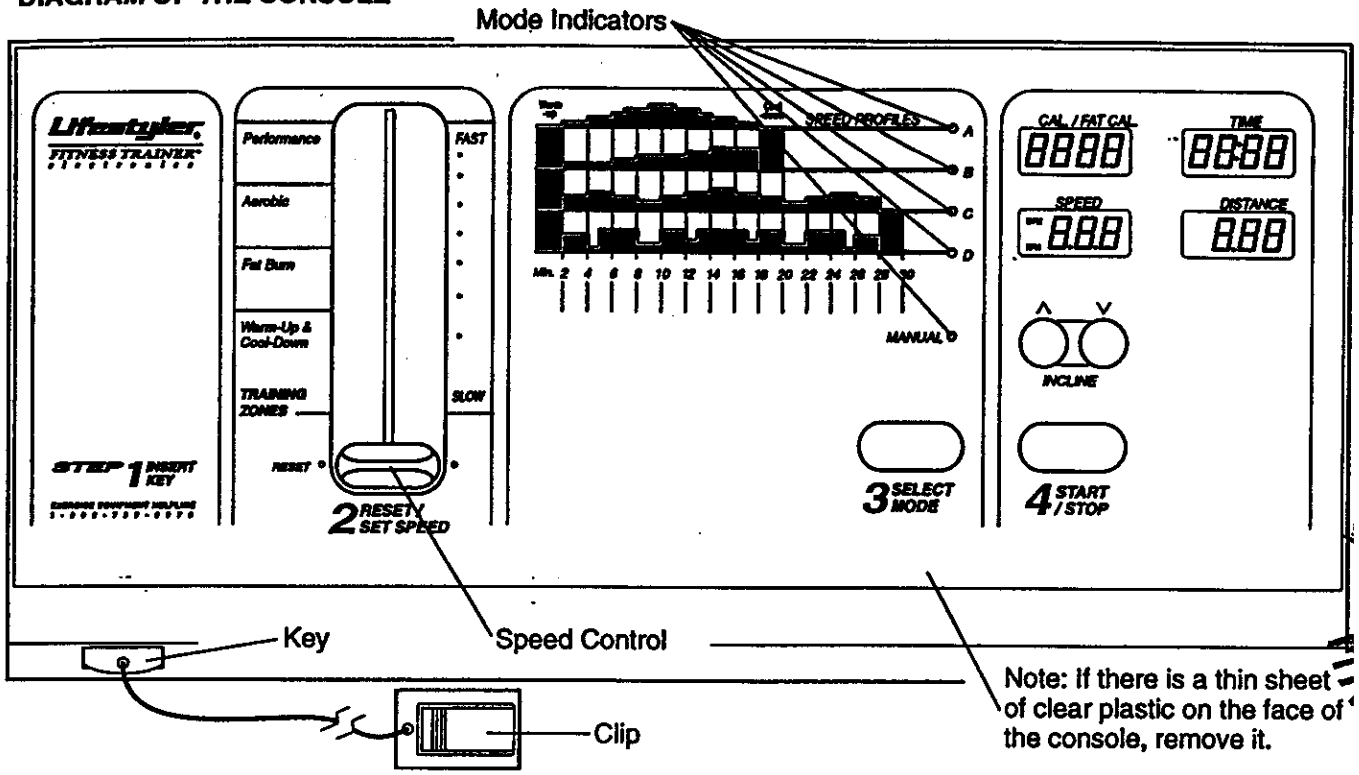

Note: If there is a thin sheet of clear plastic on the face of the console, remove it.

**CAUTION:** Before operating the console, read the following precautions:

- Do not stand on the walking belt when turning on the power.
- Always wear the clip when using the treadmill.
- Adjust the speed in small increments until you are familiar with the treadmill.
- The training zones marked beside the speed control are general guidelines only. See **CONDITIONING GUIDELINES** on page 13.

PLUG IN THE POWER CORD on page 7).

Next, step onto the foot rails of the treadmill. Find the clip attached to the key (see the drawing above), and slide the clip onto the waistband of your clothing. Follow the steps below to operate the console:

**1** Insert the key fully into the power switch.

When the key is inserted, the four displays and the green MANUAL mode indicator will light.

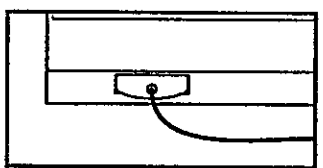

**2** Reset the speed control and select a speed setting.

Slide the speed control down to the "RESET" position. Note: Each time the walking belt is stopped, the speed control must be moved to the "RESET" position before the walking belt can be restarted.

Next, slide the speed control upward to select a speed setting. Note: If the key was just inserted, or if the walking belt was stopped with the START/STOP button, the walking belt will not begin to move yet.

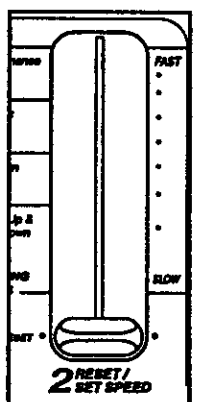

**STEP BY STEP CONSOLE OPERATION**

The treadmill console features a manual mode and four preset workout programs. In the manual mode, the speed of the walking belt can be changed with the electronic speed control. When one of the workout programs is selected, the console will automatically control the speed as it guides you through an effective workout.

Before operating the console, make sure that the on/off switch near the power cord is in the "on" position.

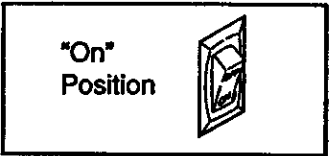

8 If the key is in the console, remove it. Make sure that the power cord is properly plugged in. (See HOW TO



**3** Press the SELECT MODE button to select the desired mode.

When the key is inserted, the console will be in the MANUAL mode.

If you want to select one of the four preset programs, press the SELECT MODE button. The red PROGRAM A indicator will light. To select PROGRAM B, C, or D, repeatedly press the SELECT MODE button.



Note: PROGRAMS A and B are twenty-minute programs; PROGRAMS C and D are thirty-minute programs. The speed profiles in the center of the console show how the speed of the walking belt will change during the programs. During PROGRAM A, for example, the speed will gradually increase during the first ten minutes, and then gradually decrease during the last ten minutes. Each program will begin with a two-minute warm-up period, and end with a two-minute cool-down period.

**4** Press the START/STOP button.

After the START/STOP button is pressed, the walking belt will begin to move. Hold the handrails and carefully begin walking on the walking belt.

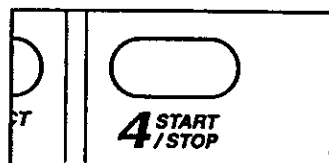

If the console is in the manual mode, change the speed of the walking belt as desired by sliding the speed control. To stop the walking belt, slide the speed control to the "RESET" position.

If one of the preset programs is selected, the speed setting you selected will be the minimum speed setting for the program. The speed of the walking belt will then change automatically during the program as shown by the speed profiles in the center of the console. When the program is completed, the walking belt will automatically slow to a stop. Note: If the intensity level of the program is too easy or too difficult, adjust the speed control to select a new minimum speed setting. To stop the program temporarily, slide the speed control to the "RESET" position. To restart the program, slide the speed control up to the desired position. To terminate the program before the program is completed, press the START/STOP button. If you select a different program or select the manual mode while a program is running, the walking belt will slow to a stop.

**5** Follow your progress with the monitor displays.

The four monitor displays provide instant feedback:

- CAL/FAT CAL display—Displays the approximate numbers of Calories and Fat Calories you have burned (see BURNING FAT on page 13). Every seven seconds, the display will change from one number to the other (an "F" will appear when the number of Fat Calories is shown). Note: The actual number of Calories you have burned may differ slightly from the number shown if the speed or incline is near the lowest or highest setting.

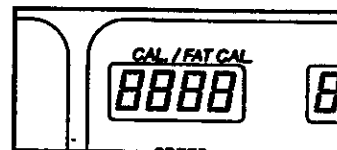

- TIME display—

When the console is in the manual mode, the elapsed time will be shown. When one of the preset programs is selected, the time remaining in the program will be displayed.

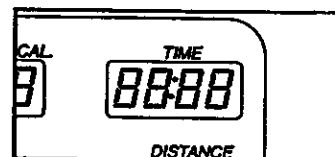

- SPEED display— Displays the speed of the walking belt, in miles per hour (MPH) or kilometers per hour (KPH).

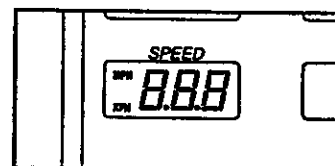

Note: To change the unit of measurement, hold down the START/STOP button while inserting

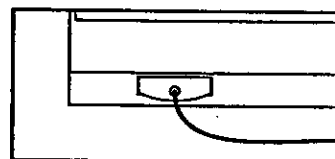

the key into the console. An "E" (for English system—miles per hour) or "M" (for Metric system—kilometers per hour) will appear in the DISTANCE display. Press the SELECT MODE button to select the desired setting. Remove and then reinsert the key. An MPH or a KPH will appear in the SPEED display to show which unit of measurement you have selected.

- DISTANCE— Displays the distance that you have walked or run. If an MPH appears in the SPEED display, the distance will be displayed in miles. If a KPH appears, the distance will be displayed in kilometers.



**6** Change the incline of the treadmill, if desired.

To vary the intensity of your workout, the incline of the treadmill can be changed. To change the incline, hold down one of the incline buttons until the desired incline is reached.

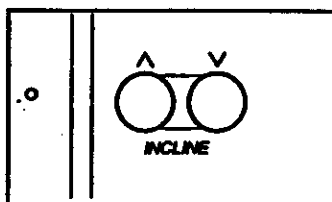

**7** When you are finished, remove the key.

When you are finished exercising, step onto the foot rails and remove the key from the console. Store the key in a secure location. In addition, move the on/off switch to the "off" position. (See the drawing near the bottom of page 8.)

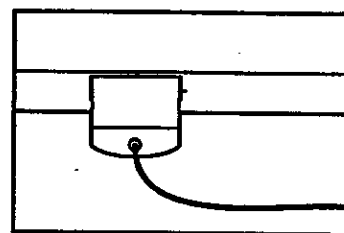

# TROUBLE-SHOOTING AND STORAGE

Most treadmill problems can be solved by following the simple steps below. Find the symptom that applies, and follow the steps listed. If further assistance is needed, call our toll-free HELPLINE at 1-800-736-6879, Monday through Saturday, 7 a.m. until 7 p.m. Central Time (excluding holidays).

## 1. SYMPTOM: THE POWER DOES NOT TURN ON

- a. Make sure that the power cord is plugged into a properly grounded outlet. (See HOW TO PLUG IN THE POWER CORD on page 7.) If an extension cord is needed, use only a 14-gauge general-purpose cord of five feet or less in length.
- b. After the power cord has been plugged in, make sure that the key is fully inserted into the console. Various indicators on the console should light. (See step 1 page 8.)
- c. Check the circuit breaker located on the treadmill near the power cord. If the switch protrudes as shown, the circuit breaker has tripped. To reset the circuit breaker, wait for five minutes and then press the switch back in.
- d. Check the on/off switch located at the front of the treadmill near the power cord. The switch must be in the "on" position.

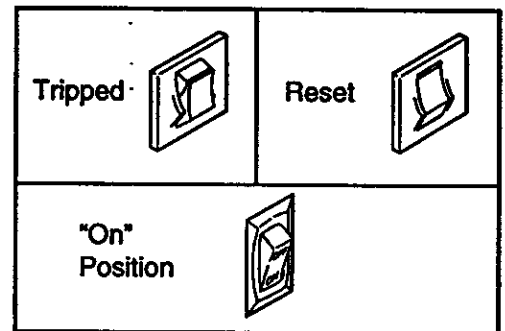

## 2. SYMPTOM: THE POWER TURNS OFF DURING USE

- a. Check the circuit breaker located on the treadmill frame near the power cord. If the circuit breaker has tripped (see the drawing above), wait for five minutes and then press the switch back in.
- b. Make sure that the power cord is plugged in.
- c. Remove the key from the console. Reinsert the key fully into the console. (See step 1 on page 8.)
- d. Check to make sure the on/off switch is in the "on" position. (See 1. d. above.)
- e. If the treadmill still will not run, please call our toll-free HELPLINE.

## 3. SYMPTOM: THE WALKING BELT SLOWS WHEN WALKED ON

- a. If an extension cord is needed, use only a 14-gauge general-purpose cord of five feet or less in length.
- b. If the walking belt still slows when walked on, please call our toll-free HELPLINE.

## 4. SYMPTOM: THE WALKING BELT IS OFF-CENTER OR SLIPS WHEN WALKED ON

- a. If the walking belt has shifted to the left, first remove the key and **UNPLUG THE POWER CORD**. Using the 3/16" allen wrench, turn the left rear roller adjustment bolt clockwise 1/4 of a turn. Plug in the power cord, insert the key and run the treadmill for a few minutes. Repeat until the walking belt is centered.

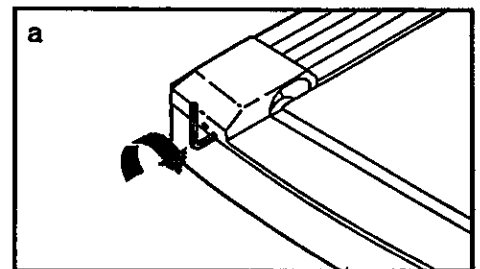

b. If the walking belt has shifted to the right, first remove the key and **UNPLUG THE POWER CORD**. Using the 3/16" allen wrench, turn the left rear roller adjustment bolt counterclockwise 1/4 of a turn. Plug in the power cord, insert the key and run the treadmill for a few minutes. Repeat until the walking belt is centered.

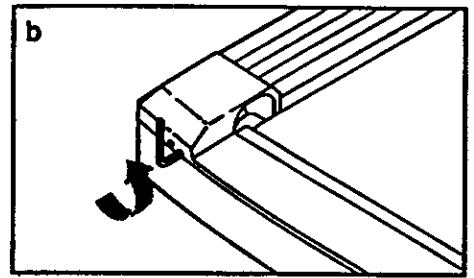

## STORAGE

Unplug the power cord when the treadmill is not in use.

Remove the indicated bolt, washer, and nut from the lower end of each upright. Loosen the other bolt and lower the upright. Keep all hardware in a secure location.

It is recommended that the treadmill be covered during extended periods of storage.

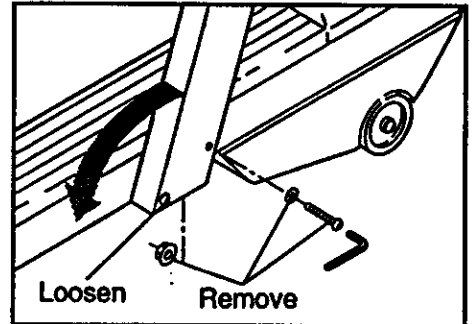

# CONDITIONING GUIDELINES

**⚠ WARNING:** Before beginning this or any exercise program, consult your physician. This is especially important for individuals over the age of 35 or individuals with pre-existing health problems.

The following guidelines will help you to plan your exercise program. Remember—these are general guidelines. For more detailed information about exercise, obtain a reputable book or consult your physician.

## EXERCISE INTENSITY

Whether you want to burn fat, strengthen your cardiovascular system, or increase your athletic performance, you can tailor your exercise to your specific goals. The key to achieving the desired results is to exercise with the proper intensity.

### Burning Fat

To burn fat effectively, you must exercise at a relatively low intensity level for a sustained period of time.

During the first few minutes of exercise, your body uses easily accessible *carbohydrate calories* for energy. Only after the first few minutes of exercise does your body begin to use stored *fat calories* for energy. If your goal is to burn fat, set the speed control on the console to FAT BURN to help you maintain the proper intensity level. (See pages 8 and 9.)

### Aerobic Exercise

If your goal is to strengthen your cardiovascular system, your exercise must be "aerobic." Aerobic exercise is activity that requires large amounts of oxygen for prolonged periods of time. This increases the demand on the heart to pump blood to the muscles, and on the lungs to oxygenate the blood. The proper intensity level for aerobic exercise can be found by using your heart rate as a guide. As you exercise, your heart rate should be kept at a level between 70% and 85% of your maximum possible heart rate. This is known as your "training zone." You can find your training zone in the table at the top of this page. Training zones are listed according to age and physical condition.

During the first few months of your exercise program, keep your heart rate near the low end of your training zone as you exercise. After a few months of regular exercise, your heart rate can be gradually increased until it is near the middle of your training zone as you exercise.

Age	Training Zone (Beats/Min.)	
	Unconditioned	Conditioned
20	138-167	133-162
25	136-166	132-160
30	135-164	130-158
35	134-162	129-156
40	132-161	127-155
45	131-159	125-153
50	129-156	124-150
55	127-155	122-149
60	126-153	121-147
65	125-151	119-145
70	123-150	118-144
75	122-147	117-142
80	120-146	115-140
85	118-144	114-139

To measure your heart rate, stop exercising and place two fingers on your wrist as shown below. Take a six-

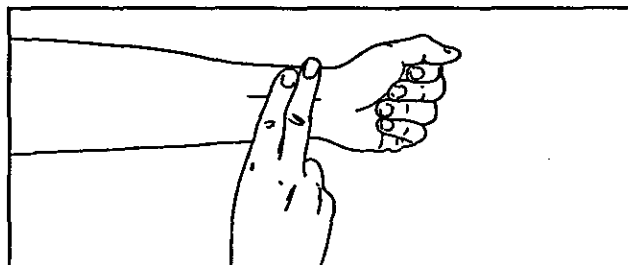

second heartbeat count, and multiply the result by ten to find your heart rate. (A six-second count is used because your heart rate drops quickly when you stop exercising.) If your heart rate is too high or too low, adjust the intensity of your exercise.

It may also be helpful to set the speed control on the console to AEROBIC to help you maintain the proper intensity level. (See pages 8 and 9.)

### Performance Training

If your goal is high performance athletic conditioning, set the speed control on the console to PERFORMANCE to help you maintain the proper intensity level. (See pages 8 and 9.)

## WORKOUT GUIDELINES

Each workout should include three basic parts: (1) a warm-up, (2) training zone exercise, and (3) a cool-down.

### Warm-up

Warming up prepares the body for exercise by increasing circulation, delivering more oxygen to the muscles and raising the body temperature. Begin each workout with 5 to 10 minutes of stretching and light exercise to warm up (see **SUGGESTED STRETCHES** on page 15).

### Training Zone Exercise

After warming up, increase the intensity of your exercise until your pulse is in your training zone for 20 to 60 minutes. (During the first few weeks of your exercise program, do not keep your pulse in your training zone for longer than 20 minutes.) Breathe regularly and deeply as you exercise—never hold your breath.

### Cool-down

Finish each workout with 5 to 10 minutes of activity similar to that of the warm-up phase. Thorough stretching offsets muscle contractions and other problems caused when you stop exercising suddenly. Stretching for increased flexibility is often most effective during this phase. This phase should leave you relaxed and comfortably tired.

Instead of waiting for a convenient time to exercise, plan a specific time. The morning hours work well for many, and the self-discipline required to rise early and exercise often carries through the day to help increase productivity in other areas. For some, exercising before dinner initiates a period of winding down from the day's activities. Whatever time you choose, be consistent and stick with it.

To maintain or improve your condition, complete three workouts each week, with at least one day of rest between workouts. After a few months of regular exercise, you may complete up to five workouts each week, if desired. Remember, the key to success is to make exercise a regular and enjoyable part of your everyday life.

## WORKOUT ATTIRE

Exercise clothing should be comfortable and allow unrestricted movement. Do not wear rubberized or plastic clothing that can interfere with the evaporation of sweat from your skin. Always wear athletic shoes that are flexible and provide good protection and support.

## ADDITIONAL SUGGESTIONS

Creating a more active lifestyle, in addition to establishing a regular exercise program, will help you to achieve your fitness goals.

It's easy to improve your lifestyle by making a few changes in your daily routine:

Keep yourself moving throughout the day. Use the stairs instead of the elevator. Park a half mile away from work or get off the bus a couple of blocks before your stop and walk the remaining distance.

Increase midday productivity, creativity and energy by replacing a heavy lunch with a light meal. Spend the extra time in physical activity such as walking.

Substitute manually-operated devices for automatic equipment such as lawn-care machinery, power tools and snow removers.

Stop smoking; smoking nearly doubles the risk of coronary heart disease. (Framingham Heart Study)

Reduce or eliminate alcohol consumption. Alcohol is a major cause of liver problems and other health disorders. (Office of Disease Prevention and Health Promotion)

Reduce your intake of fat. Less than 30% of the calories you consume each day should come from fat. Excessive fat consumption has been linked to numerous causes of death, including heart disease and cancer.

Know and keep a record of your cholesterol level, blood pressure and other health information. Keep your blood pressure below 140/90; keeping it below 125/85 is preferable.

## SUGGESTED STRETCHES

The following stretches can provide a good warm-up or cool-down. Correct form for each stretch is shown in the drawings below. Move slowly as you stretch—never bounce.

### TOE TOUCH STRETCH

Stand with your knees bent slightly and slowly bend forward from your hips. Allow your back and shoulders to relax as you reach down toward your toes as far as possible. Hold for 15 counts, then relax. Repeat 3 times.

Stretches: Hamstrings, back of knees and back.

### HAMSTRING STRETCH

Sit with one leg extended. Bring the sole of the opposite foot toward you and rest it against the inner thigh of your extended leg. Reach toward your toes as far as possible. Hold for 15 counts, then relax. Repeat 3 times for both legs.

Stretches: Hamstrings, lower back and groin.

### CALF/ACHILLES STRETCH

With one leg in front of the other, reach forward and place your hands against a wall. Keep your back leg straight and your back foot flat on the floor. Bend your front leg, lean forward and move your hips toward the wall. Hold for 15 counts, then relax. Repeat 3 times for both legs. To cause further stretching of the achilles tendons, bend your back leg as well.

Stretches: Calves, achilles tendons and ankles.

### QUADRICEPS STRETCH

With one hand against a wall for balance, reach back and grasp one foot with your other hand. Bring your heel as close to your buttocks as possible. Hold for 15 counts, then relax. Repeat 3 times for both legs.

Stretches: Quadriceps and hip muscles.

### INNER THIGH STRETCH

Sit with the soles of your feet together and your knees outward. Pull your feet toward your groin area as far as possible. Hold for 15 counts, then relax. Repeat 3 times.

Stretches: Quadriceps and hip muscles.

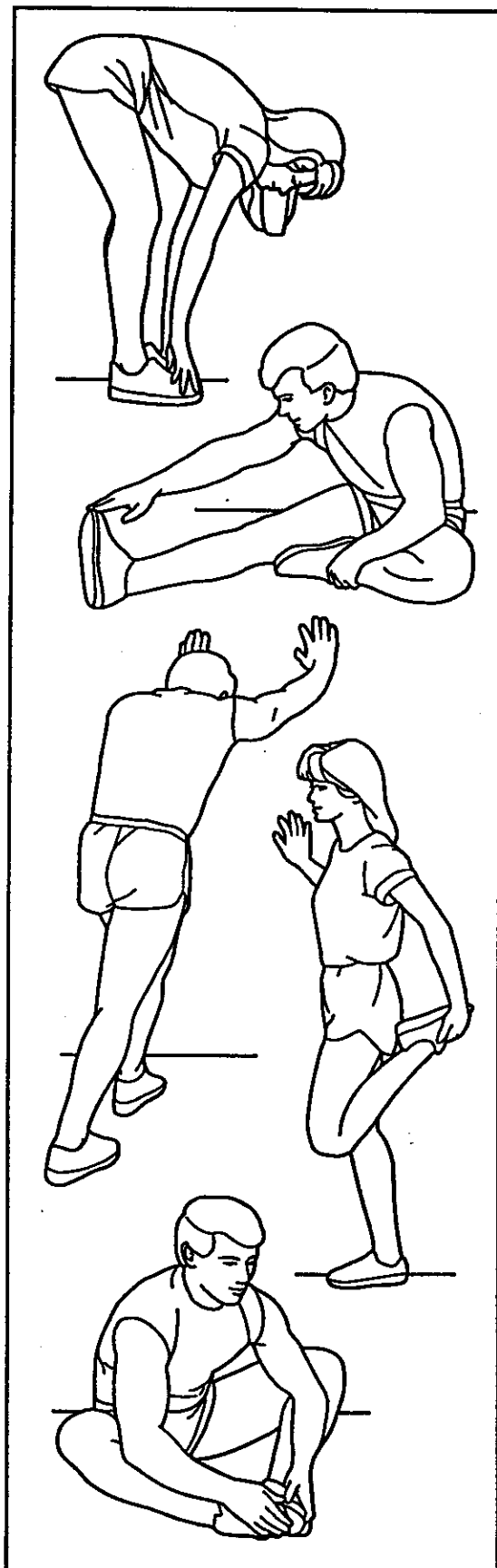

**REMOVE THIS PART LIST/EXPLODED  
DRAWING FROM THE MANUAL**

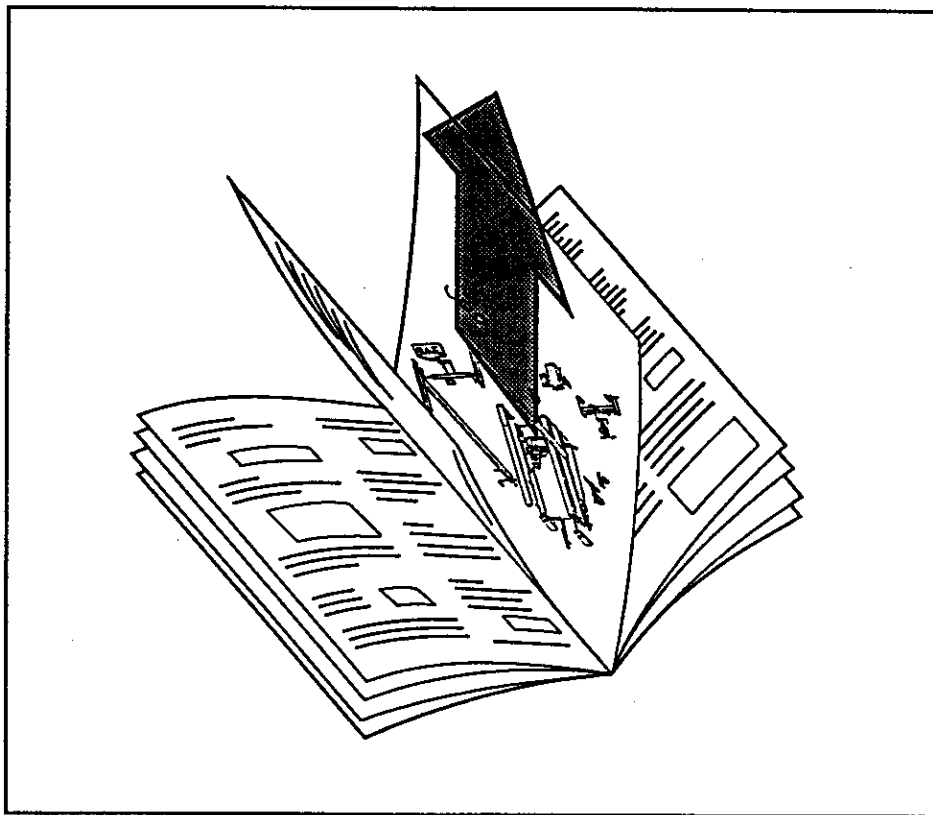

**Note: Specifications are subject to change without notice. See the back cover of the user's manual for information about ordering replacement parts.**



# EXPLODED DRAWING—Model No. 831.297492

R196A

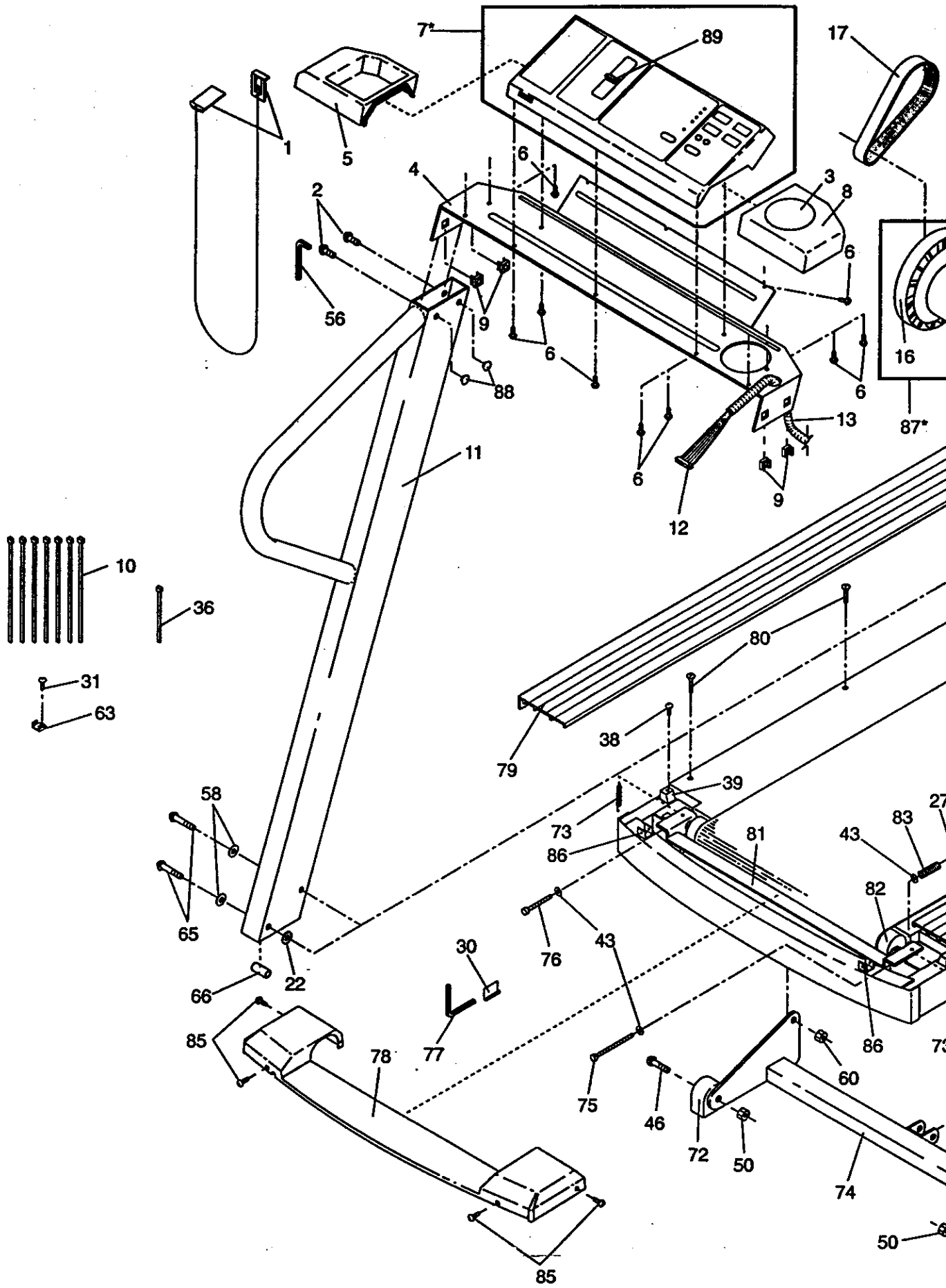

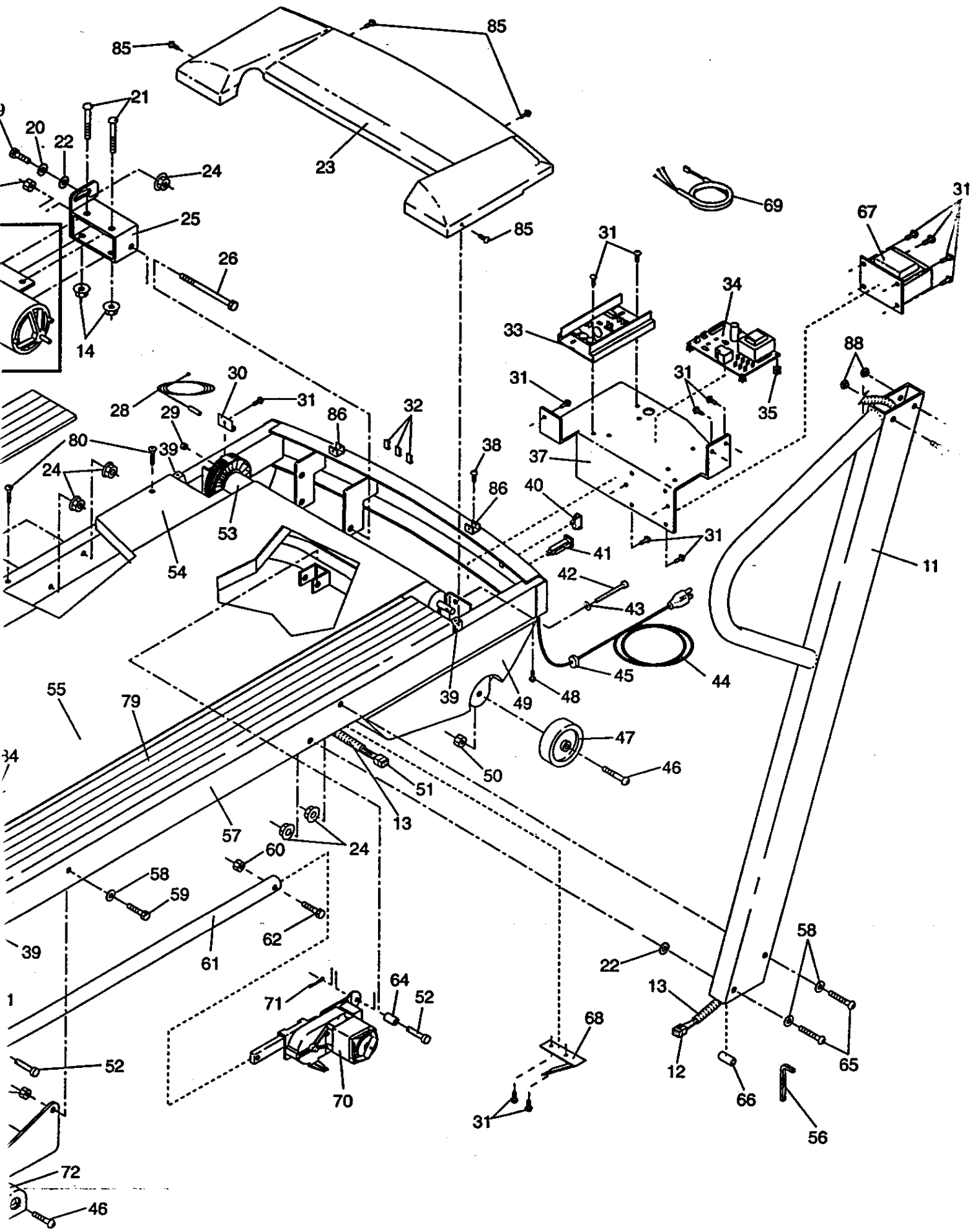

# PART LIST—Model No. 831.297492

R196A

Key No.	Part No.	Qty.	Description	Key No.	Part No.	Qty.	Description
1	119038	1	Key/Clip	51	126457	1	Short Wire Harness
2	013438	4	3/8" x 1" Console Bolt	52	112669	2	Incline Pin
3	125150	1	Water Bottle Insert	53	129022	1	Front Roller/Pulley
4	126133	1	Console Plate	54	127005	1	Walking Platform w/Fastener
5	126075	1	Console Tray	55	127007	1	Walking Belt w/Fastener
6	013322	12	Console Screw	56	045017	1	7/32" Allen Wrench
7*	128016	1	Console	57	NSP	1	Frame
8	126077	1	Water Bottle Holder	58	014132	4	3/8" Washer
9	111430	4	Cage Nut	59	013544	2	Incline Leg Bolt
10	016057	7	8" Cable Tie	60	012149	3	Incline Nut
11	125864	2	Upright	61	125855	1	Incline Rod
12	126775	1	Long Wire Harness	62	013375	1	Incline Bolt
13	113204	3	Cable Loom	63	116927	2	Tie Holder Clamp
14	105477	2	Motor Nut	64	114270	1	Incline Spacer
15	124100	1	Motor	65	123494	4	3/8" x 3 1/2" Bolt
16	112825	1	Pulley/Flywheel/Fan	66	122332	2	Upright Spacer
17	126134	1	Belt	67	109365	1	Choke
18	012108	1	Motor Pivot Nut	68	127098	2	Belt Guide
19	013547	1	Motor Tension Bolt	69	125871	1	Motor Controller Wire
20	122812	1	Motor Tension Washer	70	126058	1	Incline Motor
21	100994	2	Motor Bolt	71	106334	2	Cotter Pin
22	014117	3	Star Washer	72	125861	2	Incline Leg Foot
23	129209	1	Front Hood	73	127544	2	Rear Guard Spring
24	120867	5	Flange Nut	74	125774	1	Incline Leg
25	120785	1	Motor Mount Bracket	75	128260	1	Right Rear Adjustment Bolt
26	107503	1	Motor Swivel Bolt	76	105444	1	Left Rear Adjustment Bolt
27	123470	1	Spring Sleeve	77	126040	1	3/16" Allen Wrench
28	117882	1	Reed Switch/Wire	78	125758	1	Rear Hood
29	100498	1	Magnet	79	127566	2	Foot Rail w/Fastener
30	016028	2	Wrench Clip	80	100691	8	Platform Screw
31	120630	17	Screw	81	125860	1	Rear Roller Guard
32	054023	3	Wire Clip	82	127009	1	Rear Roller
33	129273	1	Controller	83	123469	1	Rear Roller Tension Spring
34	128903	1	Power Board w/Clips	84	119439	1	Rear Roller Tension Nut
35	125819	4	Plastic Stand-Off	85	116586	8	Hood Screw
36	016029	1	4" Wire Tie	86	127419	4	Hood Anchor
37	126046	1	Electronics Bracket	87*	124151	1	Motor/Pulley/Flywheel/Fan
38	013300	8	Anchor Screw	88	127819	4	Upright Plug
39	125802	4	Rubber Hood Anchor	89	128254	1	Speed Control
40	119163	1	On/Off Switch	#	127860	12	Fastener
41	109382	1	Circuit Breaker	#	124770	1	8" White Wire, Male/Female
42	112609	1	Front Roller Adj. Bolt	#	114953	1	14" Blue Wire, 2 Female
43	014127	5	Adjustment Washer	#	112083	1	8" Blue Wire, 2 Female
44	124669	1	Power Cord	#	109407	1	4" Black Wire, 2 Female
45	124695	1	Grommet	#	102634	1	8" Green Ground Wire
46	117806	4	Wheel Bolt	#	124768	1	14" White wire, 2 Female
47	123647	2	Wheel	#	127953	1	User's Manual
48	013162	8	Safety Cover Screw				
49	127203	1	Safety Cover				
50	012056	4	Wheel Nut				

\* Includes all the parts in the box.

# These are non-illustrated parts.



Model No. 831.297492

## QUESTIONS?

If you find that:

- you need help assembling or operating the LIFESTYLER® EXPANSE 750
- a part is missing
- or you need to schedule repair service

call our toll-free HELPLINE

**1-800-736-6879**

Monday–Saturday, 7 am–7 pm  
Central Time (excluding holidays)

## REPLACEMENT PARTS

If parts become worn and need to be replaced, call the following toll-free number

**1-800-FON-PART**  
**(1-800-366-7278)**

**holiday**

The model number and serial number of your SEARS LIFESTYLER® EXPANSE 750 treadmill are listed on a decal attached to the frame. See the front cover of this manual to find the location of the decal.

All replacement parts are available for immediate purchase or special order when you visit your nearest SEARS Service Center. To request service or to order parts by telephone, call the toll-free numbers listed at the left.

When requesting help or service, or ordering parts, please be prepared to provide the following information:

- The NAME OF THE PRODUCT (SEARS LIFESTYLER® EXPANSE 750)
- The MODEL NUMBER OF THE PRODUCT (831.297492)
- The PART NUMBER OF THE PART (see the EXPLODED DRAWING and PART LIST attached to the center of this manual)
- The DESCRIPTION OF THE PART (see the EXPLODED DRAWING and PART LIST attached to the center of this manual)

SEARS, ROEBUCK AND CO., HOFFMAN ESTATES, IL 60179 USA