

**Lifestyler**

# EXPANSE 500™

**SEARS®**

Model No. 831.297431

Serial No. \_\_\_\_\_

The serial number can be found in the location shown below. Write the serial number in the space above.

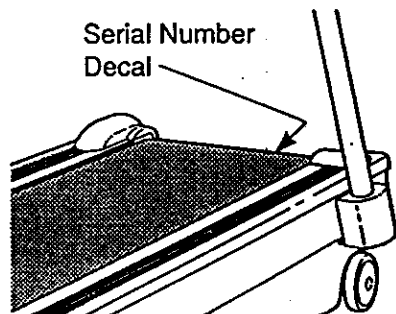

EXERCISE  
EQUIPMENT

QUESTIONS

HELPLINE!

1-800-736-6879

## ▲ CAUTION!:

Read all precautions and instructions in this manual before using this equipment. Keep this manual in a safe place for future reference.

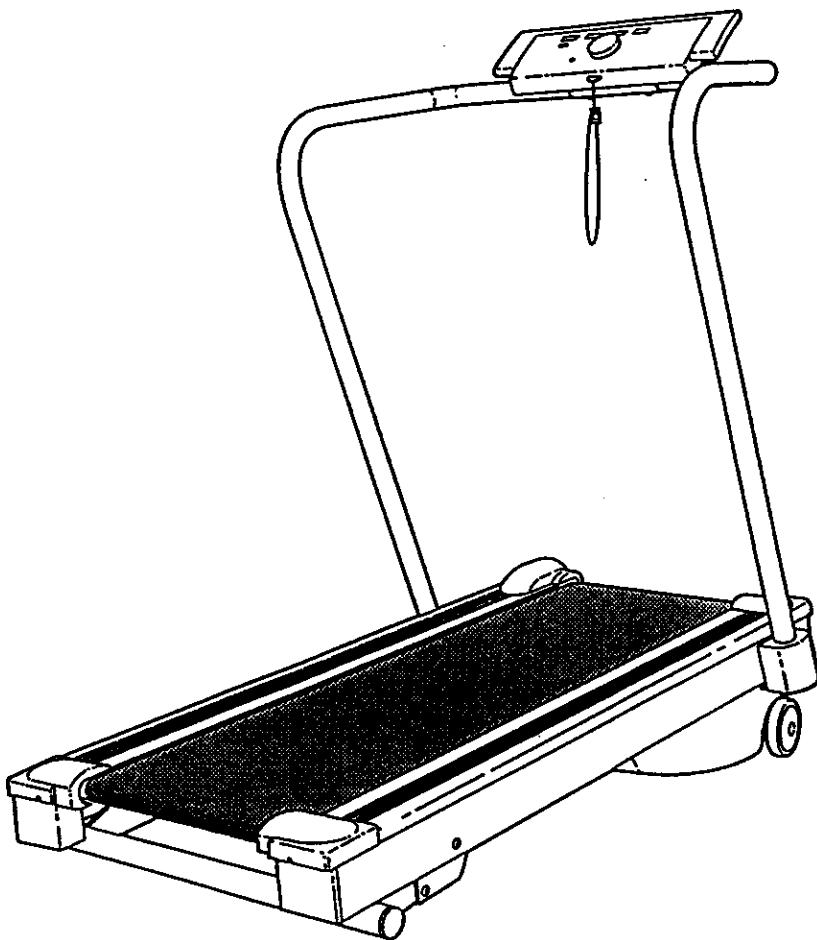

## OWNER'S MANUAL

SEARS, ROEBUCK AND CO., HOFFMAN ESTATES, IL 60179

## **FULL 90 DAY WARRANTY**

For 90 days from the date of purchase, when proper assembly and maintenance procedures detailed in the owner's manual are followed, SEARS will, free of charge, repair or replace and install a replacement part for any defective part, when this treadmill is used in a normal manner.

This warranty does not apply when this treadmill is used for commercial or rental purposes.

**SERVICE IS AVAILABLE SIMPLY BY CONTACTING YOUR NEAREST SEARS SERVICE CENTER/DEPARTMENT IN THE UNITED STATES.**

This warranty gives you specific legal rights, and you may also have other rights which vary from state to state.

**SEARS, ROEBUCK AND CO., DEPT. 817WA,  
HOFFMAN ESTATES, IL 60179**

***Lifestyler***

# EXPANSE 500™

---

## TABLE OF CONTENTS

IMPORTANT PRECAUTIONS .....	4
BEFORE YOU BEGIN .....	5
ASSEMBLY .....	6
OPERATION AND ADJUSTMENT .....	7
TROUBLE-SHOOTING AND STORAGE .....	10
CONDITIONING GUIDELINES .....	12
PART LIST .....	14
EXPLODED DRAWING .....	15
ORDERING REPLACEMENT PARTS .....	Back Cover

**▲WARNING:** Before beginning this or any exercise program, consult your physician. This is especially important for persons over the age of 35 or persons with pre-existing health problems. Read all instructions before using. SEARS assumes no responsibility for personal injury or property damage sustained by or through the use of this product.

---

## IMPORTANT PRECAUTIONS

**▲WARNING:** To reduce the risk of burns, fire, electric shock or injury to persons, read the following important precautions and information before operating the treadmill.

1. Position the treadmill on a level surface, with at least 8 feet of clearance behind the treadmill. Do not place the treadmill near water, outdoors or on any surface that blocks an air opening. Do not operate where aerosol products are used or where oxygen is being administered.
2. When connecting the power cord (see HOW TO PLUG IN THE POWER CORD on page 7), plug the power cord directly into a grounded circuit capable of carrying 12 or more amps. No other appliance should be on the same circuit. Keep the power cord away from heated surfaces. If an extension cord is needed, use only a 14-gauge general-purpose cord of five feet or less in length with a three-wire conductor.
3. Never move the walking belt while the power is turned off. Do not operate the treadmill if the power cord or plug is damaged, or if the treadmill is not working properly. (See BEFORE YOU BEGIN on page 5 if the treadmill is not working properly.)
4. Wear appropriate exercise clothing when using the treadmill; do not wear loose clothing that could become caught in the treadmill. *Always wear athletic shoes; never use the treadmill with bare feet, wearing only stockings or in sandals.* Athletic support clothes are recommended for both men and women.
5. Never start the treadmill while you are standing on the walking belt. Always hold the handrail when exercising on the treadmill.
6. Never allow more than one person on the treadmill at a time. The treadmill should not be used by persons weighing more than 250 pounds.
7. Keep small children away from the treadmill at all times.
8. Never leave the treadmill unattended while it is running.
9. Always remove the safety key when the treadmill is not in use.
10. Never drop or insert any object into any opening.
11. To reduce the possibility of overheating, do not operate the treadmill continuously for longer than 1 hour.
12. The treadmill is capable of high speeds. Adjust the speed slowly to avoid sudden jumps in speed.
13. Use the treadmill only as described in this manual.
14. Always unplug the power cord before performing the maintenance and adjustment procedures described in this manual. Never remove the safety cover unless instructed to do so by an authorized service representative. Servicing other than the procedures in this manual should be performed by an authorized service representative only.

**SAVE THESE INSTRUCTIONS**

# BEFORE YOU BEGIN

Thank you for selecting the SEARS LIFESTYLER® EXPANSE 500 treadmill. The EXPANSE 500 treadmill blends advanced technology with innovative design to let you enjoy an excellent form of cardiovascular exercise in the convenience and privacy of your home.

For your benefit, read this manual carefully before using the treadmill. If you have additional questions, please call our toll-free HOTLINE at 1-800-736-6879, Monday through Saturday, 7 a.m. until 7 p.m. Central

Time (excluding holidays). To help us assist you, please note the product model number and serial number before calling. The model number of the treadmill is 831.297431. The serial number can be found on a decal attached to the treadmill (see the front cover of this manual for the location).

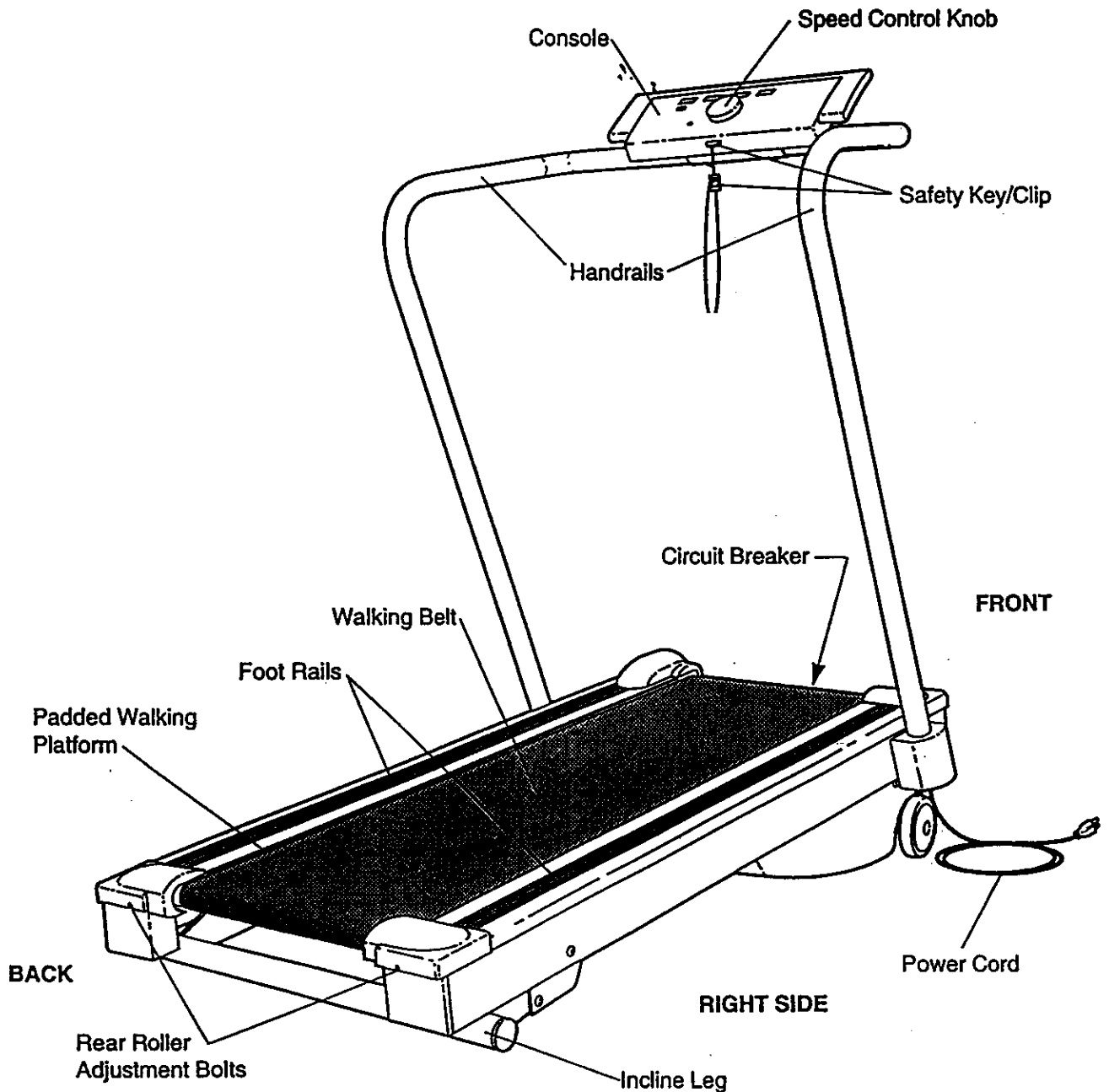

Before reading further, please review the drawing below and familiarize yourself with the parts that are labeled.



Note: The incline leg pad may mark some types of linoleum. Mild household cleaning agents will remove any marks.

# ASSEMBLY

Set the treadmill in a cleared area and remove all packing materials. Do not dispose of the packing materials until assembly is completed.

**THE FOLLOWING TOOLS ARE REQUIRED FOR ASSEMBLY:** The Included 7/32" allen wrench  and your own adjustable wrench .

1. Raise the Right Handrail (12) to a vertical position. Align the hole in the lower end of the Right Handrail with the hole in the side of the Frame (36). Insert one of the three 3/8" x 2" Bolts (28) into the Right Handrail, and tighten the Bolt into the Frame. Tighten the Bolt that is already in the Right Handrail.

Press the Right Handrail Cap (27) onto the lower end of the Right Handrail (12). Note: It may be necessary to push the 12" Cable Loom (10) into the Right Handrail.

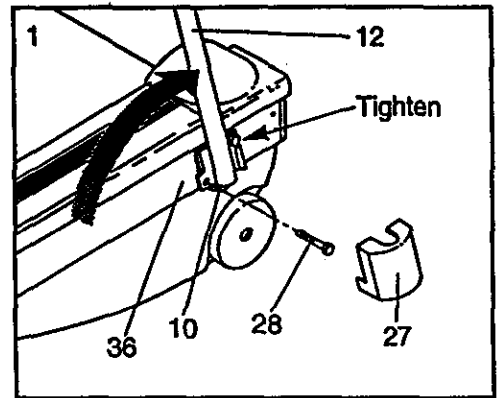

2. Using the 7/32" Allen Wrench (9), loosen the Handrail Bolt that is under the Console (6). Rotate the Console to the position shown. Insert the upper end of the Left Handrail (1) into the left side of the Console. Insert a Handrail Bolt (2) into the bottom of the Console and the Left Handrail (1). Finger tighten the Handrail Bolt.

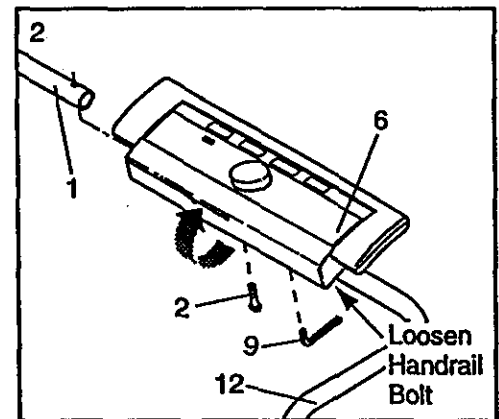

3. Align the holes in the lower end of the Left Handrail (1) with the holes in the treadmill Frame (36). Tighten a 3/8" x 2" Bolt (28) into each hole.

Press the Left Handrail Cap (68) onto the lower end of the Left Handrail (1).

See step 2. Using the 7/32" Allen Wrench (9), tighten the two Handrail Bolts (2) under the Console (6).

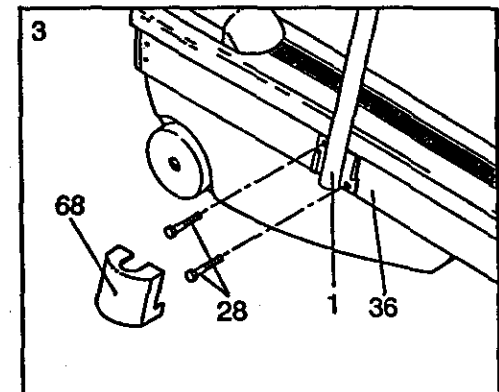

4. Remove the paper backing from the Wrench Clip (16). Press the Wrench Clip onto the Rear Endcap (59) in the indicated location. Press the 3/16" Allen Wrench (58) into the Wrench Clip.

Make sure that all parts are tightened before using the treadmill. Note: Cover the floor underneath the treadmill for protection.

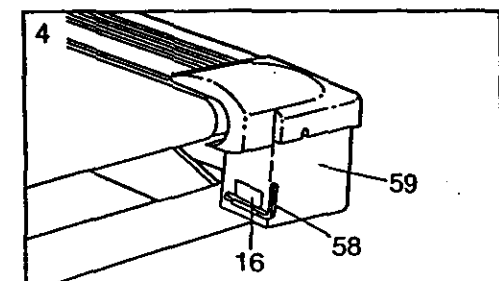

# OPERATION AND ADJUSTMENT

## MAINTENANCE-FREE WALKING BELT

Your treadmill features a maintenance-free walking belt coated with PERFORMANT LUBE™, a high-performance lubricant. During the first few hours of use, a small amount of white powder may accumulate on the foot rails and the walking platform. The white powder is high-performance lubricant from the walking belt. Never apply silicone spray or other substances to the walking belt or the walking platform. They will deteriorate the walking belt and cause excessive wear.

## HOW TO PLUG IN THE POWER CORD

This product must be grounded. If it should malfunction or break down, grounding provides a path of least resistance for electric current to reduce the risk of electric shock. This product is equipped with a cord having an equipment-grounding conductor and a grounding plug. Plug the power cord into an appropriate outlet that is properly installed and grounded in accordance with all local codes and ordinances.

**⚠ DANGER:** Improper connection of the equipment-grounding conductor can result in a risk of electric shock. Check with a qualified electrician or serviceman if you are in doubt as to whether the product is properly grounded. Do not modify the plug provided with the product—if it will not fit the outlet, have a proper outlet installed by a qualified electrician.

This product is for use on a nominal 120-volt circuit, and has a grounding plug that looks like the plug illustrated in drawing 1 below.

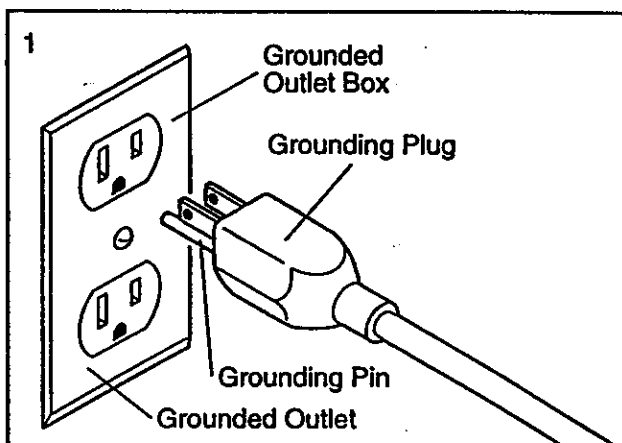

A temporary adapter that looks like the adapter illustrated in drawing 2 may be used to connect this plug to a 2-pole receptacle as shown in drawing 2 if a properly grounded outlet is not available. The tempo-

rary adapter should be used only until a properly grounded outlet (drawing 1) can be installed by a qualified electrician. The green-colored rigid ear, lug, or the like extending from the adapter must be connected to a permanent ground such as a properly grounded outlet box cover. Whenever the adapter is used it must be held in place by a metal screw. Some 2-pole receptacle outlet box covers are not grounded. Contact a qualified electrician to determine if the outlet box cover is grounded before using an adapter.

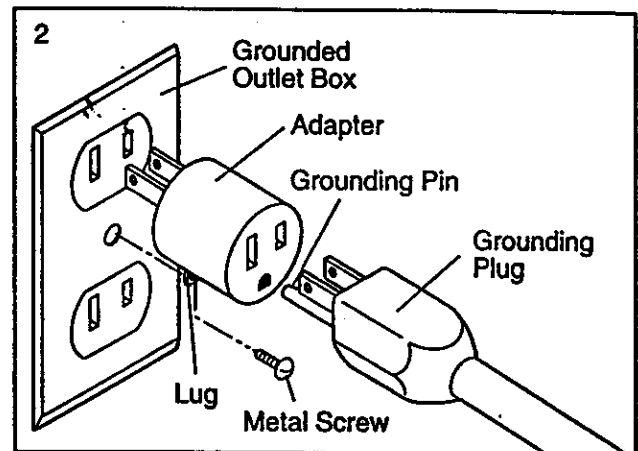

## HOW TO CHANGE THE INCLINE OF THE TREADMILL

The incline of the treadmill can be changed by raising or lowering the back end. Before changing the incline, remove the safety key and unplug the power cord.

Place one foot on the incline leg near the sticker, and grasp the rear roller with both hands. **CAUTION:** Do not place your hands under the frame, or they may be pinched. Do not lift on the endcaps or they may be damaged. When the back end of the treadmill is in the lowest position, the incline is about 10%. Raise the back end until it clicks into position. The incline will then be about 5%. Raise the back end again until it clicks into position. The incline will then be about 3%. To lower the back end, first raise it past the highest position, and then lower it. **CAUTION:** Before exercising on the treadmill, push slightly on the back of the treadmill to make sure that the incline leg is locked in position.

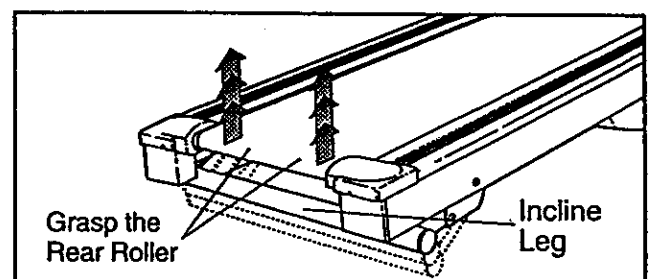

## DIAGRAM OF THE CONSOLE

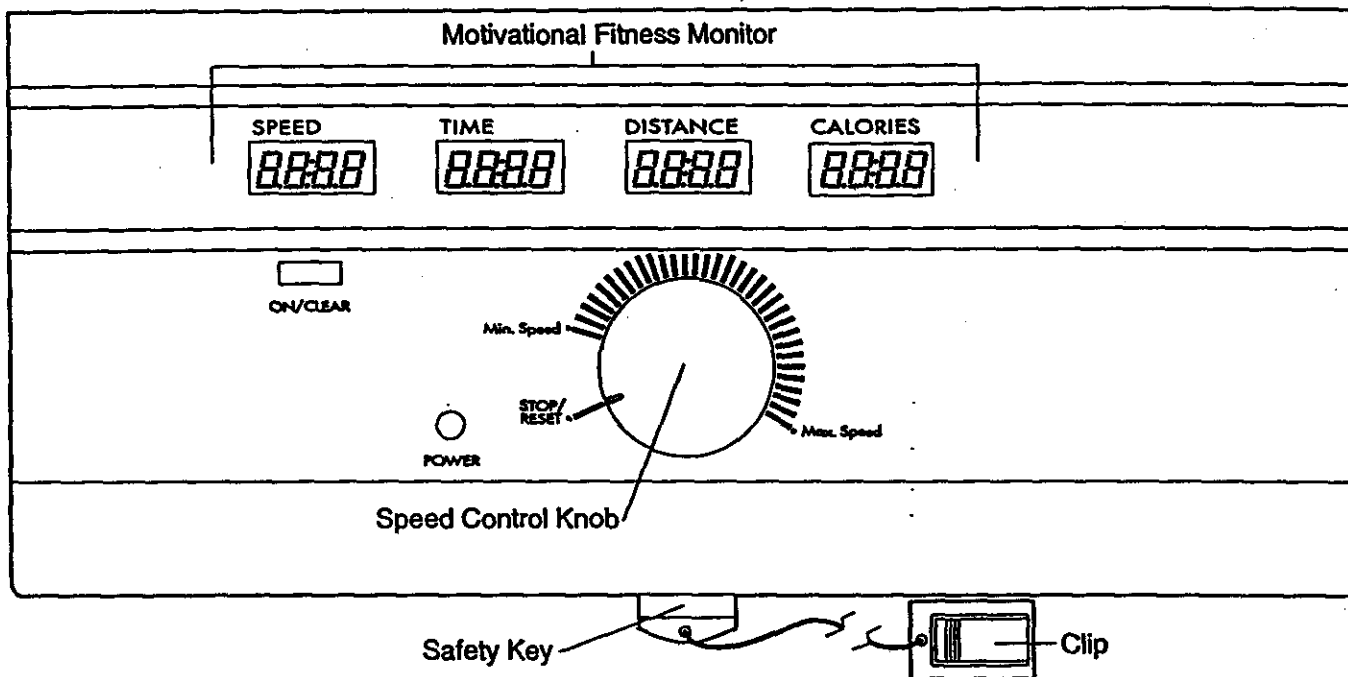

The heart of the treadmill is the innovative console. The console features a safety key-operated power switch, electronic speed control and four independent displays to provide continuous exercise feedback. Please read these instructions carefully before operating the console. **Note:** If there is a sheet of protective plastic on the face of the console, peel it off before operating the console.

### INSTALLING BATTERIES

The motivational fitness monitor requires two "AA" batteries (not included); alkaline batteries are recommended. Slide open the battery cover located on the underside of the console. Remove the battery clip from the console. Find the markings inside the battery clip showing which direction the batteries should be turned. Press the batteries into the battery clip. Replace the battery clip in the console and close the battery cover.

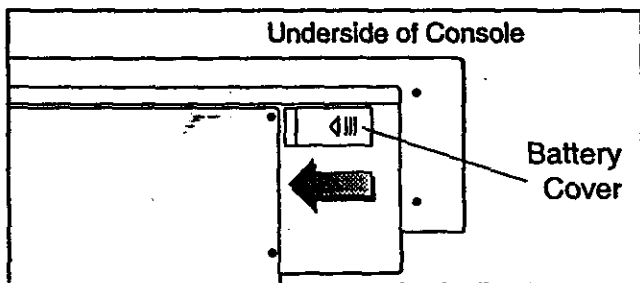

### HOW TO TURN ON THE POWER

Stand on the foot rails of the treadmill. Do not stand on the endcaps or they may be damaged. Find the clip attached to the safety key, and clip it onto your waistband.

**CAUTION:** Do not stand on the walking belt when turning on the power. Always wear the clip while operating the treadmill.

Insert the safety key into the power switch. The power indicator will light. The four displays of the motivational fitness monitor will not appear until the ON/CLEAR button is pressed, or the walking belt begins to move (see CONTROLLING THE SPEED below). **Note:** If batteries were just installed, the four displays will already appear.

### CONTROLLING THE SPEED

To start the walking belt, first turn the speed control knob to "STOP/RESET." Then, turn the knob slowly clockwise until the walking belt begins to move at slow speed. Do not let your feet touch the walking belt when standing on the foot rails.

**CAUTION:** After the knob is turned, there will be a pause before the walking belt begins to move. Adjust the speed slowly until you are familiar with the operation of the treadmill.

Carefully step onto the walking belt and begin exercising. Change the speed of the walking belt as desired by turning the speed control knob. To stop the walking belt, turn the knob to "STOP/RESET."

### MOTIVATIONAL FITNESS MONITOR

The four displays of the motivational fitness monitor provide continuous exercise feedback. The displays can be reset by pressing the ON/CLEAR button. The four displays are described below:



**SPEED**—This display shows the current speed of the walking belt, in miles per hour.

**TIME**—This display shows the elapsed time. Note: When the walking belt is stopped, the TIME display will go into a pause mode after a few seconds.

**DISTANCE**—This display shows the total distance that you have walked or run, in miles.

**CALORIES**—This display shows the approximate number of nutritional Calories that you have burned.

**Note:** If the walking belt is stopped and remains stationary for about four minutes, the four displays of the

motivational fitness monitor will be reset and will darken, although the power will remain on. The four displays will appear again when the ON/CLEAR button is pressed, or the walking belt is restarted.

#### **TURNING OFF THE POWER**

To turn off the power, remove the safety key from the console. The power indicator will darken. Store the safety key in a secure location.

#### **PADDED WALKING PLATFORM**

The treadmill features a padded walking platform that adds to your comfort as you exercise on the treadmill.

# TROUBLE-SHOOTING AND STORAGE

Most treadmill problems can be solved by following the simple steps below. Find the symptom that applies, and follow the steps listed. If further assistance is needed, call our toll-free HOTLINE at 1-800-736-6879, Monday through Saturday, 7 a.m. until 7 p.m. Central Time (excluding holidays).

## 1. SYMPTOM: THE POWER DOES NOT TURN ON

- Make sure that the power cord is plugged into a properly grounded outlet. (See HOW TO PLUG IN THE POWER CORD on page 7.) If an extension cord is needed, use only a 14-gauge general-purpose cord of five feet or less in length.
- After the power cord has been plugged in, make sure that the safety key is fully inserted into the console. Various indicators on the console should light. (See HOW TO TURN ON THE POWER on page 8.)
- Check the circuit breaker located on the treadmill near the power cord. If the switch protrudes as shown, the circuit breaker has tripped. To reset the circuit breaker, wait for five minutes and then press the switch back in.

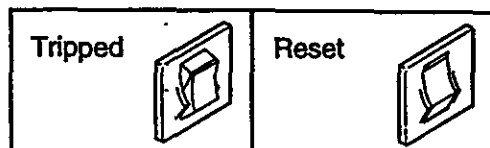

## 2. SYMPTOM: THE POWER TURNS OFF DURING USE

- Check the circuit breaker located on the treadmill near the power cord. If the circuit breaker has tripped (see the drawing above), wait for five minutes and then press the switch back in.
- Make sure that the power cord is plugged in.
- Remove the safety key from the console. Reinsert the safety key fully into the console. Various indicators on the console should light.

## 3. SYMPTOM: THE WALKING BELT SLOWS WHEN WALKED ON

- If an extension cord is needed, use only a 14-gauge general-purpose cord of five feet or less in length.
- If the walking belt is overtightened, treadmill performance may decrease and the walking belt may be permanently damaged. Remove the safety key and **UNPLUG THE POWER CORD**. Using the 3/16" allen wrench, turn both rear roller adjustment bolts counterclockwise, 1/4 of a turn. When the walking belt is properly tightened, you should be able to lift each side of the walking belt 3-4 inches off the walking platform. The center of the walking belt should just touch the walking platform. Be careful to keep the walking belt centered. Plug in the power cord, insert the safety key and run the treadmill for a few minutes. Repeat until the walking belt is properly tightened.

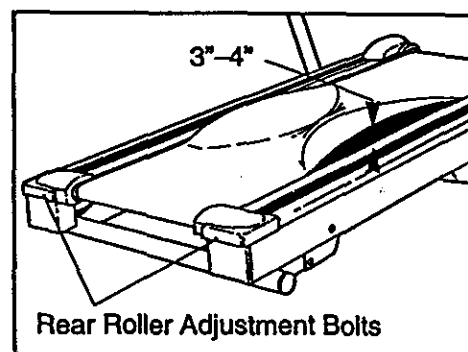

- If the walking belt still slows when walked on, please call our Customer Service Department.

## 4. SYMPTOM: THE WALKING BELT IS OFF-CENTER OR SLIPS WHEN WALKED ON

- If the walking belt has shifted to the left, first remove the safety key and **UNPLUG THE POWER CORD**. Using the 3/16" allen wrench, turn the left rear roller adjustment bolt clockwise, and the right bolt counterclockwise, 1/4 of a turn each. Be careful not to overtighten the walking belt. Plug in the power cord, insert the safety key and run the treadmill for a few minutes. Repeat until the walking belt is centered.

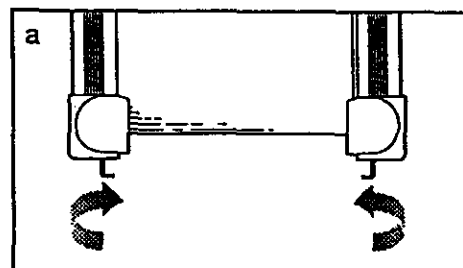

b. If the walking belt has shifted to the right, first remove the safety key and **UNPLUG THE POWER CORD**. Using the 3/16" allen wrench, turn the left rear roller adjustment bolt counterclockwise, and the right bolt clockwise, 1/4 of a turn each. Be careful not to overtighten the walking belt. Plug in the power cord, insert the safety key and run the treadmill for a few minutes. Repeat until the walking belt is centered.

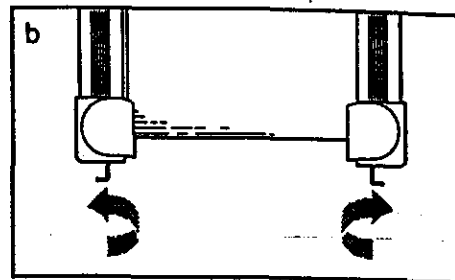

c. If the walking belt slips when walked on, first remove the safety key and **UNPLUG THE POWER CORD**. Using the 3/16" allen wrench, turn both rear roller adjustment bolts clockwise, 1/4 of a turn. When the walking belt is correctly tightened, you should be able to lift each side of the walking belt 3-4 inches off the walking platform. The center of the walking belt should just touch the walking platform. Be careful to keep the walking belt centered. Plug in the power cord, insert the safety key and run the treadmill for a few minutes. Repeat until the walking belt is properly tightened.

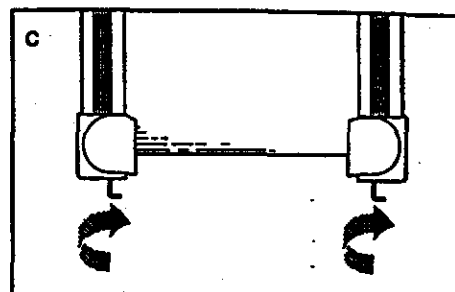

## STORAGE

Unplug the power cord when the treadmill is not in use.

Remove the left handrail cap and the two bolts from the lower end of the left handrail (see drawing 1).

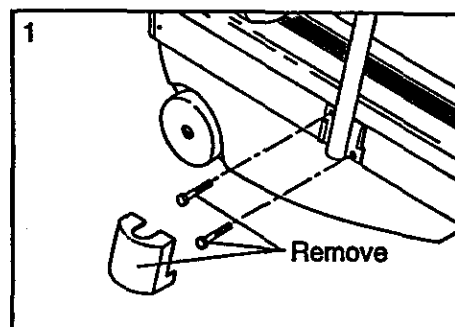

Using the 7/32" allen wrench, remove the bolt from the upper end of the left handrail (see drawing 2). Slide the handrail out and lay it on the treadmill.

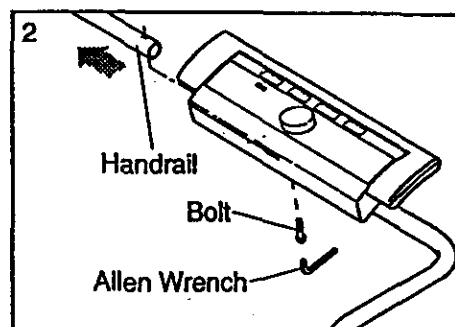

Remove the right handrail cap and the bolt from the lower end of the right handrail. Loosen the other bolt in the handrail (see drawing 3). Lay the right handrail on the treadmill.

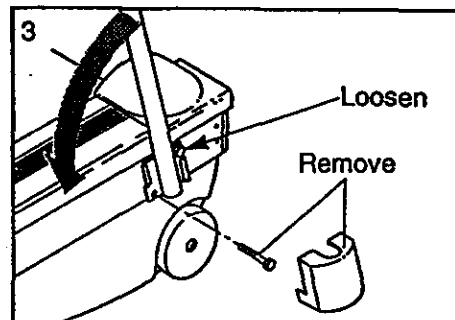

It is recommended that the treadmill be covered during extended periods of storage.

# CONDITIONING GUIDELINES

The following guidelines will help you to plan your exercise program. Remember that proper nutrition and adequate rest are essential for successful results.

**⚠ WARNING:** Before beginning this or any exercise program, consult your physician. This is especially important for individuals over the age of 35 or individuals with pre-existing health problems.

## EXERCISE INTENSITY

To maximize the benefits of exercising, it is important to exercise with the proper intensity. The proper intensity level can be found by using your heart rate as a guide. For effective aerobic exercise, your heart rate should be maintained at a level between 70% and 85% of your maximum heart rate as you exercise. This is known as your training zone. You can find your training zone in the table below. Training zones are listed for both unconditioned and conditioned persons according to age.

AGE	UNCONDITIONED TRAINING ZONE (BEATS/MIN)	CONDITIONED TRAINING ZONE (BEATS/MIN)
20	138-167	133-162
25	136-166	132-160
30	135-164	130-158
35	134-162	129-156
40	132-161	127-155
45	131-159	125-153
50	129-156	124-150
55	127-155	122-149
60	126-153	121-147
65	125-151	119-145
70	123-150	118-144
75	122-147	117-142
80	120-146	115-140
85	118-144	114-139

During the first few months of your exercise program, keep your heart rate near the low end of your training zone as you exercise. After a few months, your heart rate can be increased gradually until it is near the middle of your training zone as you exercise.

To measure your heart rate, stop exercising and place two fingers on your wrist as shown below.

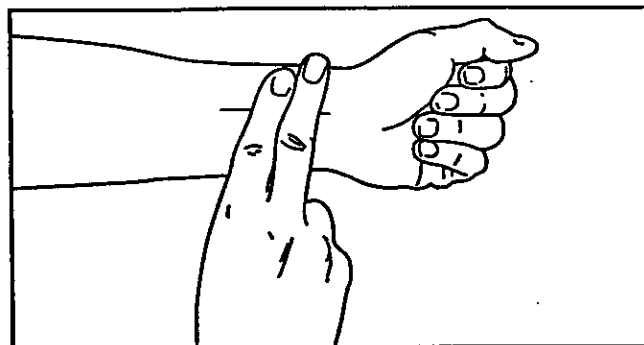

Take a six-second heartbeat count, and multiply the result by 10 to find your heart rate. For example, if your six-second heartbeat count is 14, your heart rate is 140 beats per minute. (A six-second count is used because your heart rate will drop rapidly when you stop exercising.) Adjust the intensity of your exercise until your heart rate is at the proper level.

## WORKOUT GUIDELINES

Each workout should consist of three basic parts: a warm-up, 20 to 30 minutes of training zone exercise, and a cool-down.

Warming up prepares the body for exercise by increasing circulation, delivering more oxygen to the muscles and raising the body temperature. Begin each workout with 5 to 10 minutes of stretching and light exercise to warm up.

Next, increase the intensity of your exercise to raise your heart rate to your training zone for 20 to 30 minutes. Breathe regularly and deeply as you exercise—never hold your breath.

Finish each workout with 5 to 10 minutes of stretching to cool down. Stretching after exercise is very effective for increasing flexibility.

To maintain or improve your condition, complete three workouts each week, with at least one day of rest between workouts. After a few months of regular exercise, you may complete up to five workouts each week, if desired.

The key to success is to make exercise an enjoyable part of your everyday life.

## SUGGESTED STRETCHES

The following stretches can provide a good warm-up or cool-down. Correct form for each stretch is shown in the drawings below. Move slowly as you stretch—never bounce.

### TOE TOUCH STRETCH

Stand with your knees bent slightly and slowly bend forward from your hips. Allow your back and shoulders to relax as you reach down toward your toes as far as possible. Hold for 15 counts, then relax. Repeat 3 times.

Stretches: Hamstrings, back of knees and back.

### HAMSTRING STRETCH

Sit with one leg extended. Bring the sole of the opposite foot toward you and rest it against the inner thigh of your extended leg. Reach toward your toes as far as possible. Hold for 15 counts, then relax. Repeat 3 times for both legs.

Stretches: Hamstrings, lower back and groin.

### CALF/ACHILLES STRETCH

With one leg in front of the other, reach forward and place your hands against a wall. Keep your back leg straight and your back foot flat on the floor. Bend your front leg, lean forward and move your hips toward the wall. Hold for 15 counts, then relax. Repeat 3 times for both legs. To cause further stretching of the achilles tendons, bend your back leg as well.

Stretches: Calves, achilles tendons and ankles.

### QUADRICEPS STRETCH

With one hand against a wall for balance, reach back and grasp one foot with your other hand. Bring your heel as close to your buttocks as possible. Hold for 15 counts, then relax. Repeat 3 times for both legs.

Stretches: Quadriceps and hip muscles.

### INNER THIGH STRETCH

Sit with the soles of your feet together and your knees outward. Pull your feet toward your groin area as far as possible. Hold for 15 counts, then relax. Repeat 3 times.

Stretches: Quadriceps and hip muscles.

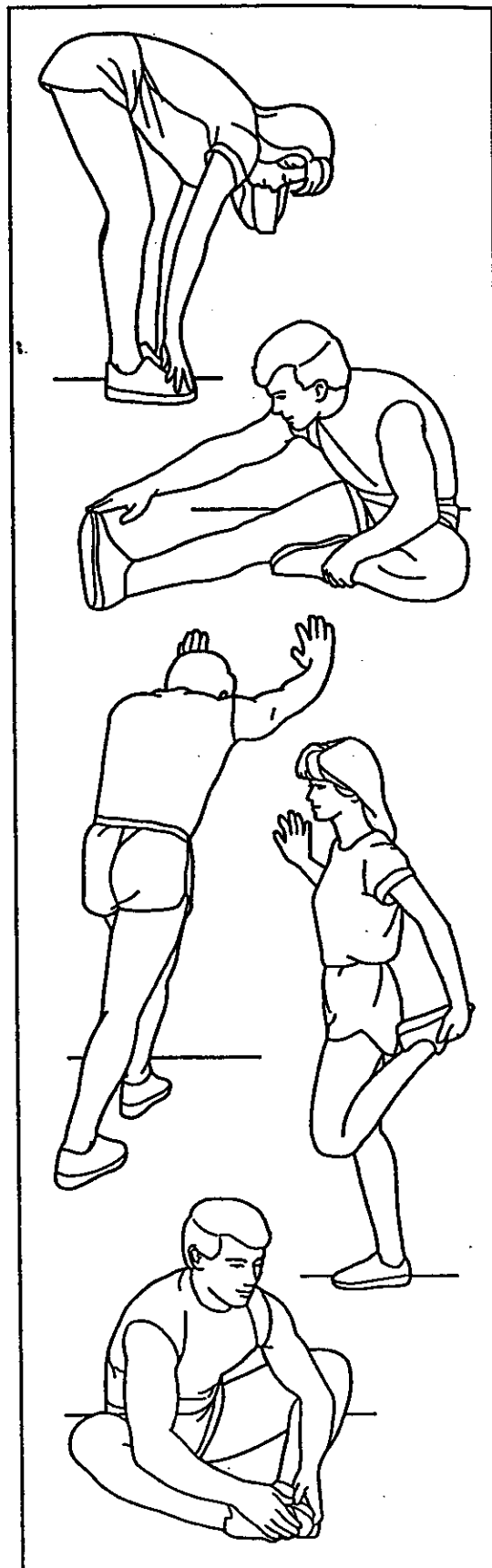

# PART LIST—Model No. 831.297431

R695A

Key No.	Part No.	Qty.	Description	Key No.	Part No.	Qty.	Description
1	123635	1	Left Handrail	42	124565	4	Incline Leg Spring
2	122137	2	Handrail Bolt	43	107503	1	Motor Pivot Bolt
3	111869	4	Cage Nut	44	123666	2	Incline Leg Latch
4	119038	1	Safety Key/Clip	45	122363	1	Controller Plate
5	110000	1	Speed Control Knob	46	122871	1	Controller
6	124150	1	Console	47	016057	1	8" Wire Tie
7	123897	1	Wire Harness	48	123676	2	Incline Bolt
8	123637	1	Console Plate	49	013547	1	Motor Lock Bolt
9	045017	1	7/32" Allen Wrench	50	124292	1	Pulley Cover Bracket
10	103643	2	12" Cable Loom	51	012108	1	Motor Swivel Nut
11	013141	5	Console Screw	52	014105	4	Incline Leg Washer
12	123633	1	Right Handrail	53	123627	1	Incline Leg
13	123993	1	Pulley Cover	54	116980	2	Incline Leg Endcap
14	013322	12	Endcap Screw	55	123961	2	Incline Leg Pad
15	124147	1	Front Roller/Pulley	56	116927	1	Cable Tie Clip
16	016028	2	Adhesive Clip	57	116926	1	Cable Tie
17	118153	1	Reed Switch	58	123355	1	3/16" Allen Wrench
18	118195	1	Extension Wire	59	123992	1	Right Rear Endcap
19	054023	4	Wire Clip	60	105444	2	Rear Roller Adj. Bolt
20	109382	1	Circuit Breaker	61	123991	1	Left Rear Endcap
21	124695	1	Grommet	62	109788	1	Rear Roller
22	124669	1	Power Cord	63	100691	8	Platform Screw
23	112609	1	Front Roller Adj. Bolt	64	124146	1	Padded Walking Platform
24	014127	3	Adjustment Washer	65	124380	8	Endcap U-Nut
25	123994	1	Front Right Endcap	66	125323	1	Left Foot Rail
26	105477	2	Motor Nut	67	031238	1	Choke
27	123922	1	Right Handrail Cap	68	123921	1	Left Handrail Cap
28	013601	4	3/8" x 2" Bolt	69	122812	1	Motor Tension Washer
29	117806	2	Wheel Bolt	70	014117	1	Star Washer
30	120630	14	Small Screw	71	120867	1	Motor Tension Nut
31	123647	2	Front Wheel	72	122632	1	Motor Mount Bracket
32	012056	6	Front Wheel Nut/Incline Leg Nut	73	112825	1	Pulley/Flywheel/Fan
33	124318	2	Belt Guide	74	118017	1	Motor Belt
34	123648	1	Safety Cover	75	100994	2	Motor Bolt
35	013162	10	Safety Cover Screw	76	124100	1	Motor
36	NSP	1	Frame	77	117992	1	Safety Cover Plug
37	124148	1	Right Foot Rail	78	108080	4	Choke Screw/Plate Screw
38	111430	2	Console Cage Nut	#	123898	1	White 2 Wire Jumper
39	124145	1	Walking Belt	#	115868	1	12" Pot Extension Wire
40	016029	1	4" Wire Tie	#	124886	1	Owner's Manual
41	123622	2	Incline Leg Bolt				

# EXPLODED DRAWING—Model No. 831.297431

R695A

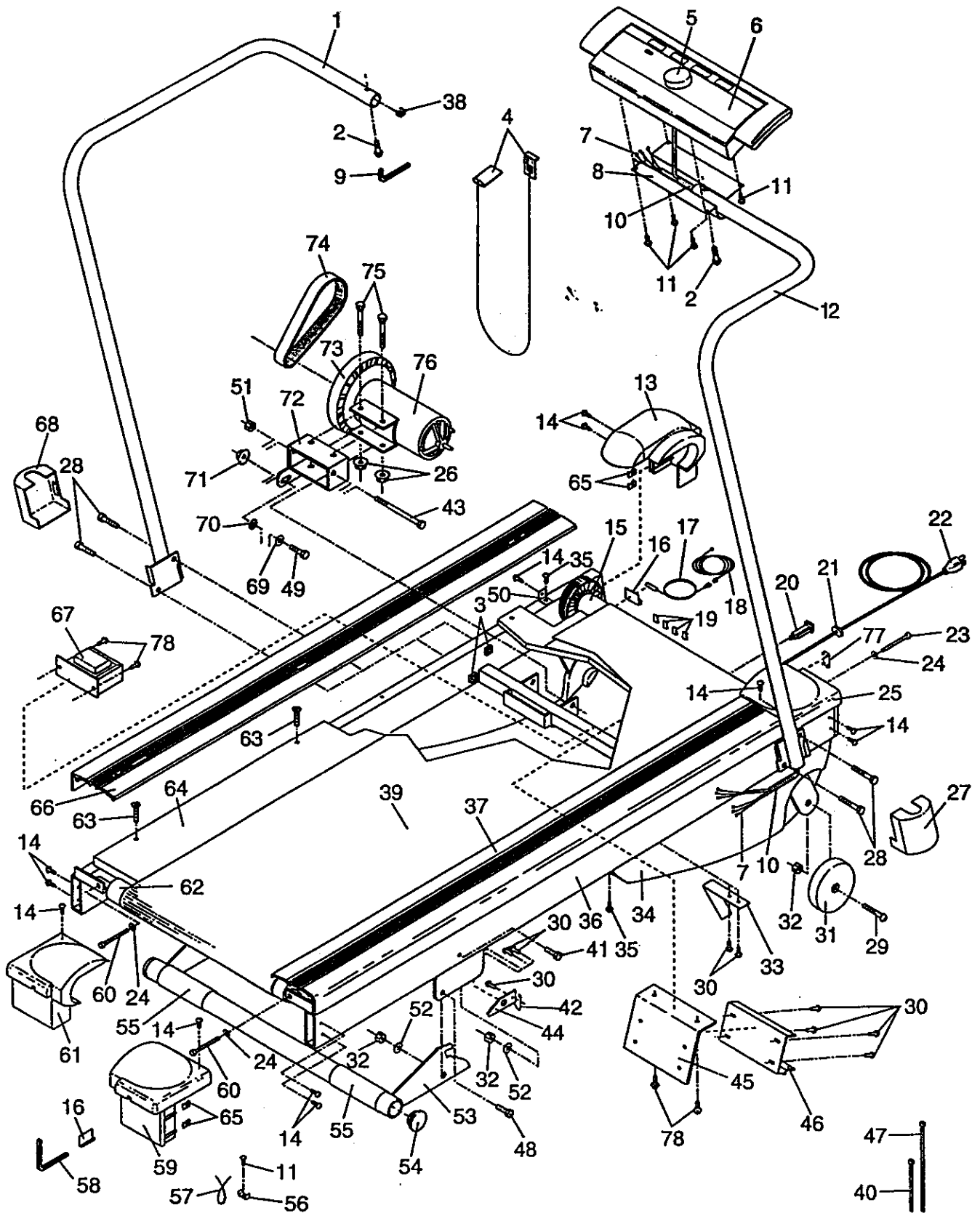



Model No. 831.297431

## QUESTIONS?

If you find that:

- you need help assembling or operating the LIFESTYLER EXPANSE 500
- a part is missing
- or you need to schedule repair service

call our toll-free HELPLINE

**1-800-736-6879**

Monday-Saturday, 7 am-7 pm  
Central Time (excluding holidays)

## REPLACEMENT PARTS

If parts become worn and need to be replaced, call the following toll-free number

**1-800-FON-PART**

**(1-800-366-7278)**

The model number and serial number of your SEARS LIFESTYLER® EXPANSE 500 treadmill are listed on a decal attached to the frame. See the front cover of this manual to find the location of the decal.

All replacement parts are available for immediate purchase or special order when you visit your nearest SEARS Service Center. To request service or to order parts by telephone, call the toll-free numbers listed at the left.

When requesting help or service, or ordering parts, please be prepared to provide the following information:

- The NAME OF THE PRODUCT (SEARS LIFESTYLER® EXPANSE 500)
- The MODEL NUMBER OF THE PRODUCT (831.297431)
- The PART NUMBER OF THE PART (see page 14 of this manual)
- The DESCRIPTION OF THE PART (see page 14 of this manual)

SEARS, ROEBUCK AND CO., HOFFMAN ESTATES, IL 60179 USA