

WESLO[®] cardioWALK[™]

SEARS

Model No. 831.150190

Serial No. _____

The serial number can be found in the location shown below. Write the serial number in the space above.

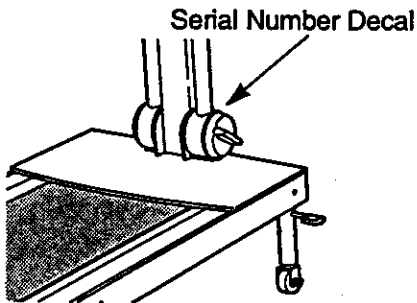

EXERCISE
EQUIPMENT

QUESTIONS

HELPLINE!

CAUTION

Read all precautions and instructions in this manual before using this equipment. Keep this manual for future reference.

US PATENT 5,102,380

US PATENT 5,282,776

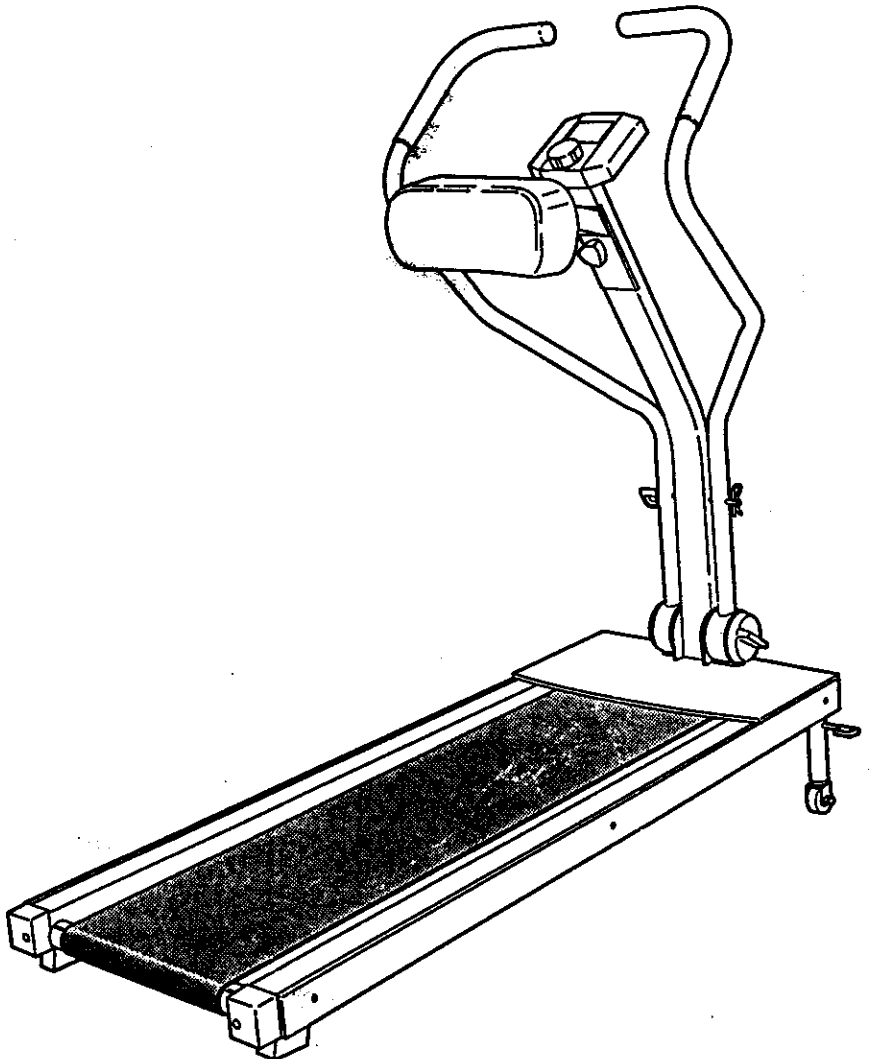

USER'S MANUAL

TABLE OF CONTENTS

IMPORTANT PRECAUTIONS	2
BEFORE YOU BEGIN	3
ASSEMBLY	4
TREADMILL OPERATION	5
TROUBLE-SHOOTING	7
CONDITIONING GUIDELINES	9
PART LIST	10
EXPLODED DRAWING	11
ORDERING REPLACEMENT PARTS	Back Cover
WARRANTY	Back Cover

IMPORTANT PRECAUTIONS

▲ WARNING: To reduce the risk of serious injury, read the following important precautions before using the **CARDIO WALK**.

1. Place the **CARDIO WALK** on a level surface, with at least 8 feet of clearance behind it. It is recommended that you cover the floor beneath the **CARDIO WALK**.
2. Keep small children and pets away from the **CARDIO WALK** at all times.
3. The **CARDIO WALK** should be used only by persons weighing 250 pounds or less. Never allow more than one person on the **CARDIO WALK** at a time.
4. Wear appropriate clothing when exercising. Never wear loose clothing that could become caught in the **CARDIO WALK**. Always wear athletic shoes; never use the **CARDIO WALK** with bare feet, wearing only stockings, or in sandals. Athletic support clothes are recommended for both men and women.
5. Inspect and tighten all parts regularly. Replace any worn parts immediately.
6. Do not use the **CARDIO WALK** if it is not working properly.
7. Do not place hands or feet under the **CARDIO WALK** while it is in use.
8. Always hold the upper body arms when exercising on the **CARDIO WALK**.
9. If you feel pain or dizziness at any time while exercising, stop immediately and begin cooling down.
10. Use the **CARDIO WALK** only as described in this manual.

SAVE THESE INSTRUCTIONS

▲ WARNING: Before beginning this or any exercise program, consult your physician. This is especially important for persons over the age of 35 or persons with pre-existing health problems. Read all instructions before using this product. SEARS assumes no responsibility for personal injury or property damage sustained by or through the use of this product.

BEFORE YOU BEGIN

Thank you for selecting the WESLO® CARDIO WALK Dual Motion Manual Treadmill. The natural motion and versatility of treadmills have made them the most popular way to get an effective cardiovascular workout. With the dual motion design of the CARDIO WALK, you can get both an upper- and lower-body workout as well.

To help you stay motivated as you exercise, the CARDIO WALK features an electronic console that provides continuous feedback of speed, elapsed time, total distance, and the approximate number of Calories you have burned. And the adjustability of the CARDIO WALK allows you to work at your own level, whether you are just beginning or already exercise regularly.

For your benefit, read this manual carefully before using the CARDIO WALK. If you have additional questions, please call our toll-free HELPLINE at 1-800-736-6879, Monday through Saturday, 7 a.m. until 7 p.m. Central Time (excluding holidays). To help us assist you, please note the product model number and serial number before calling. The model number is 831.150190. The serial number can be found on a decal attached to the CARDIO WALK (see the front cover of this manual to find the location of the decal).

Before reading further, please review the drawing below and familiarize yourself with the parts that are labeled.

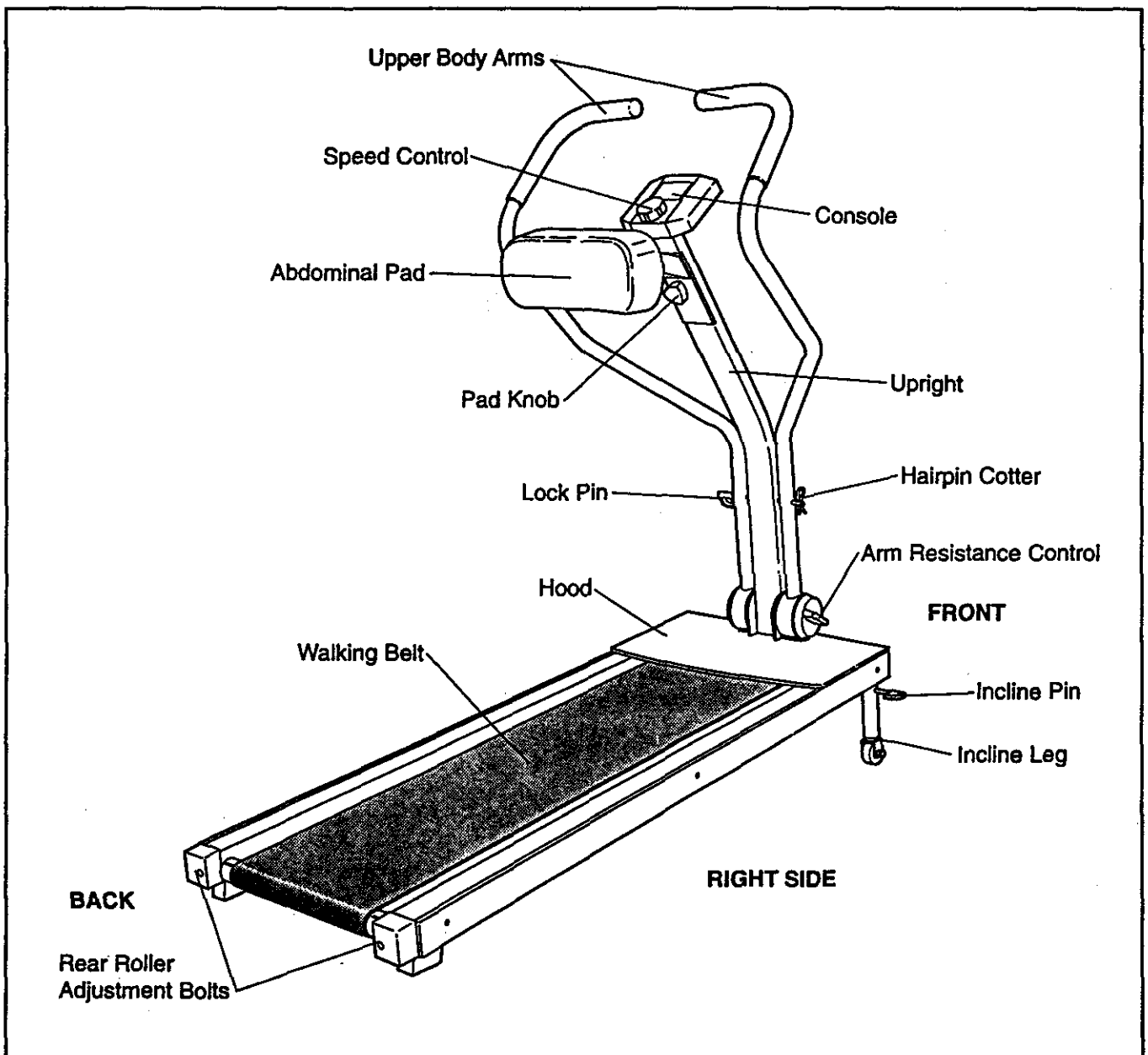

ASSEMBLY

Set the **CARDIO WALK** in a cleared area and remove all packing materials. Do not dispose of the packing materials until assembly is completed. Assembly requires the included allen wrench

1. Raise the Upright (10) to the vertical position. Slide the Upright Flat Washer (25) onto the Upright Bolt (24). Tighten the Upright Bolt into the Upright with the Allen Wrench (53).

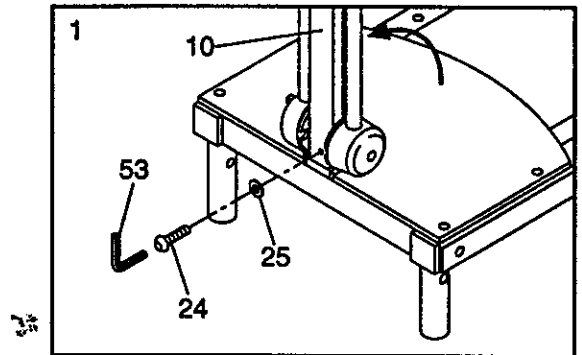

2. Insert an Incline Leg (9) into one of the adjustment posts on the Frame (37). Align one of the holes in the Incline Leg with the hole in the adjustment post. Insert an Incline Pin (26) through the adjustment post and the Incline Leg.

Assemble the other Incline Leg (9) in the same manner. Make sure that both Incline Legs are at the same height.

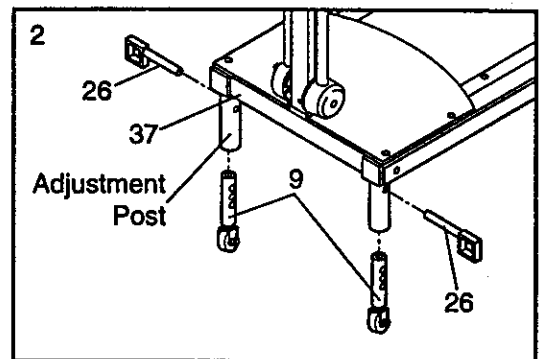

3. Attach the Abdominal Pad Bracket (72) to the Upright (10) with the Pad Knob (52) and Washer (17). (The three holes in the Upright are for height adjustment. Select the height that is the most comfortable.) Be sure that the Abdominal Pad (33) is oriented as shown.

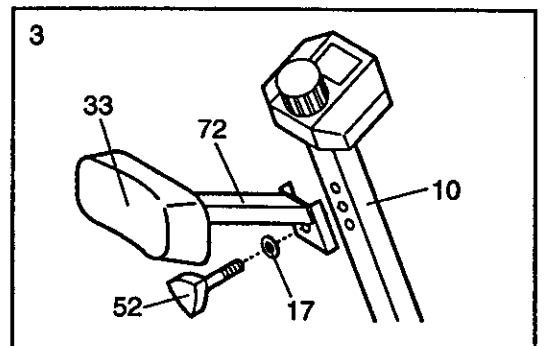

4. Remove the paper backing from the Wrench Clip (50). Attach the Wrench Clip to the underside of the Frame (37) as shown. Slide the Allen Wrench (53) into the Wrench Clip.

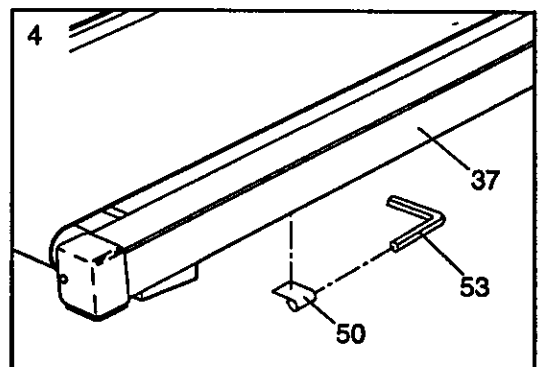

Because there are moving parts on the underside of the treadmill, it is recommended that you cover the floor beneath the treadmill. The walking platform is pre-lubricated with **PERFORMANT LUBE™** high performance lubricant. During the first few hours of use, it is normal for a white powder to collect on the floor under the treadmill and on the sides of the walking belt. This powder is excess lubricant.

TREADMILL OPERATION

CONSOLE MODES

The console features a selection of modes to provide you with continuous feedback as you exercise. The five modes are described below:

SPEED—Displays your current speed, in miles per hour.

TIME—Displays the elapsed time. Note: If the walking belt stops for ten seconds or longer, the TIME mode will pause until you resume walking.

DISTANCE—Displays the total distance that you have walked, in miles.

CALORIE—Displays the total number of nutritional calories you have burned. Note: The number displayed is an approximate figure. The actual number may vary slightly depending on the incline of the treadmill and the resistance settings.

SCAN—Displays all of the above modes, for five seconds each, in a repeating cycle.

simply begin walking. The entire display will appear for two seconds; the console will then be ready for operation.

2. Select one of the five modes:

SCAN mode—When the power is turned on, the SCAN mode will be selected automatically. One mode indicator will show that the SCAN mode has been selected, and a second mode indicator will show which mode is currently displayed. The SCAN mode can also be selected by repeatedly pressing the mode button.

SPEED, TIME, DISTANCE or CALORIE mode—These modes can be selected by repeatedly pressing the mode button. A mode indicator will show which mode has been selected. The modes are selected in the following order: SPEED, TIME, DISTANCE, CALORIE, and SCAN.

3. To reset the modes, turn the power off and then on again by pressing the on/off button twice.

4. To turn off the power, press the on/off button. Note: If the walking belt is not moved and the console buttons are not pressed for four minutes, the power will turn off automatically in order to conserve the batteries.

CONSOLE DIAGRAM

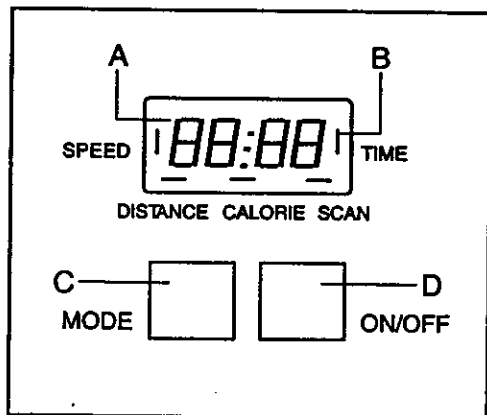

A. LCD display.

B. Mode indicators—Show which mode is currently selected.

C. Mode button—Selects modes.

D. On/off button—Turns the power on and off.

HOW TO WALK ON THE TREADMILL

Stand on the walking belt, hold the upper body arms, and lean on the abdominal pad. (See HOW TO USE THE UPPER BODY ARMS on page 6). Slowly begin walking on the treadmill. Use the upper body arms for balance and lean on the abdominal pad to “push off” when you begin walking. **Always hold the upper body arms when getting on and off the treadmill, and when exercising on the treadmill.**

Because the **CARDIO WALK** is a manual treadmill, you can set your own exercise pace. There are three ways that you can change the intensity of your workout:

- You can change the resistance on the walking belt. (See HOW TO USE THE SPEED CONTROL on page 6.)
- You can increase the resistance of the upper body arms. (See HOW TO USE THE UPPER BODY ARMS on page 6.)
- You can increase the incline of the treadmill. (See HOW TO CHANGE THE INCLINE on page 6.)

OPERATING THE CONSOLE

1. If there is a thin piece of clear plastic on the console, remove it before operating the console. To turn on the power, press the on/off button or

HOW TO USE THE SPEED CONTROL

As you exercise on the **CARDIO WALK**, you can change the resistance on the walking belt by turning the **Speed Control (57)** on the **Console (7)**. As the **Speed Control** is turned clockwise, the resistance on the walking belt will increase and your walking speed will decrease. As the **Speed Control** is turned counterclockwise, the resistance will decrease and the walking belt will move more freely.

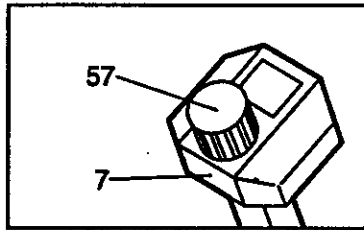

Note: Do not use the adjustment bolts to increase the resistance on the walking belt. The walking belt must be able to move smoothly for the **CARDIO WALK** to operate properly. (See **TROUBLESHOOTING** on page 8.)

HOW TO USE THE UPPER BODY ARMS

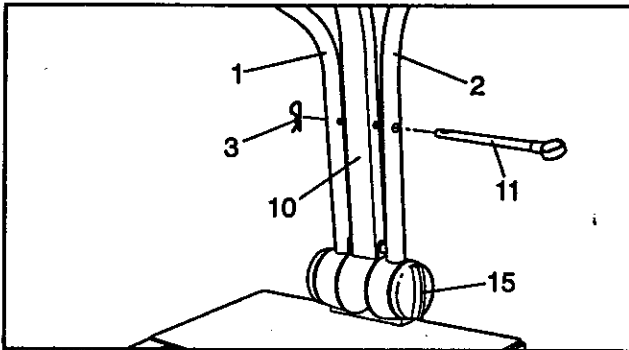

The **Upper Body Arms (1, 2)** can be used in either the stationary position or the dual motion position. To use the **Upper Body Arms** in the stationary position, insert the **Lock Pin (11)** through the **Upper Body Arms** and the **Upright (10)**. **Important:** If it is difficult to insert the **Lock Pin**, do not hit the end of the **Lock Pin**; twist the **Upper Body Arms** slightly in order to align the holes. Do not twist the **Upper Body Arms** too far or the treadmill may be damaged. Insert the **Hairpin Cotter (3)** into the end of the **Lock Pin**. Tighten the **Arm Resistance Control (15)**.

CAUTION: Always secure the **Lock Pin (11)** with the **Hairpin Cotter (3)**. If the **Hairpin Cotter** is not attached as instructed, the **Lock Pin** may slip out, resulting in injury to the user.

To use the **Upper Body Arms (1, 2)** in the dual motion position, first make sure that the **Arm Resistance Control (15)** is tightened (see the drawing above).

Remove the **Lock Pin (11)** from the **Upper Body Arms (1, 2)** and the **Upright (10)**. In the dual motion position, you can move the **Upper Body Arms** forward and back as you walk, exercising your arms, back and shoulders for a total body workout. To tailor the intensity of your exercise, the resistance of the **Upper Body Arms** can be changed. To increase the resistance, turn the **Arm Resistance Control (15)** clockwise; to decrease the resistance, turn the **Arm Resistance Control** counterclockwise.

HOW TO CHANGE THE INCLINE

To change the incline, first lift the front of the treadmill slightly and remove the **Incline Pin (26)** from one **Incline Leg (9)** (see the drawing below).

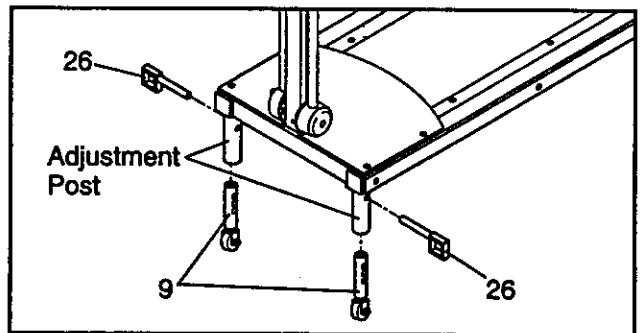

Position the **Incline Leg (9)** at the desired height, align one of the holes in the **Incline Leg** with the hole in the **adjustment post**, and insert the **Incline Pin (26)** through the **adjustment post** and the **Incline Leg**. Adjust the other **Incline Leg** in the same manner. **Make sure that the Incline Pins are fully inserted and that both Incline Legs are at the same height.**

HOW TO ADJUST THE ABDOMINAL PAD

For your comfort, the height of the **Abdominal Pad (33)** can be adjusted (see the drawing below). There are three height settings. To change the height setting, first remove the **Pad Knob (52)** and **Washer (17)**. Align the hole in the **Abdominal Pad Extension (72)** with the desired hole in the **Upright (10)**. Secure the **Abdominal Pad Bracket** with the **Pad Knob**.

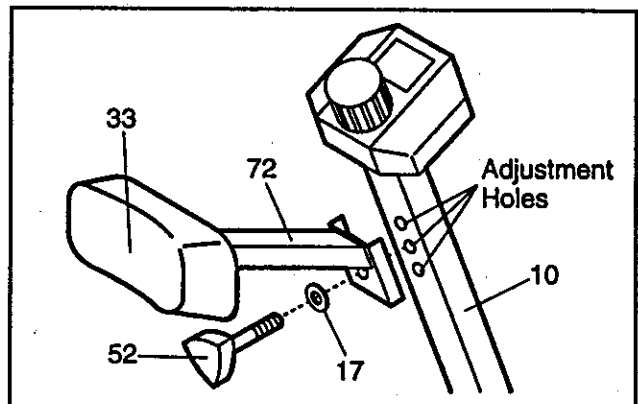

BATTERY REPLACEMENT

The Console (7) requires two "LR44" watch batteries. To replace the batteries, first remove three of the screws that attach the Console to the Upright (10). Loosen the fourth screw. Pivot the Console until the batteries are visible (see the drawing below).

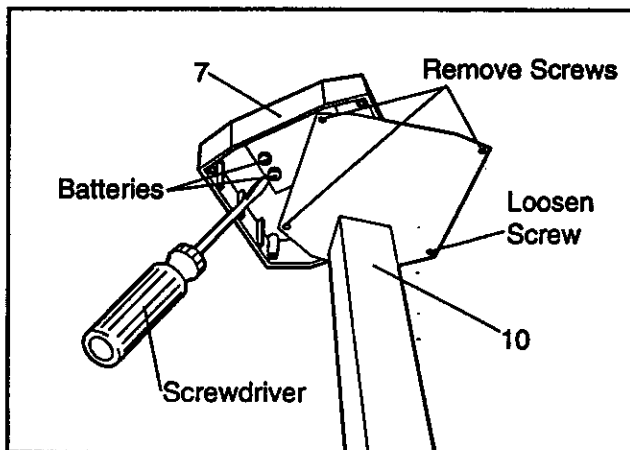

Using a small screwdriver, push the batteries out of the Console (7). Be sure to note which way the batteries were turned. Insert two new batteries. Re-attach the Console to the Upright (10).

HOW TO STORE THE TREADMILL

To convert the treadmill to the storage position, first turn the Arm Resistance Control (15) counter-clockwise until it turns freely (see the drawing below). Failure to do so will result in damage to the treadmill.

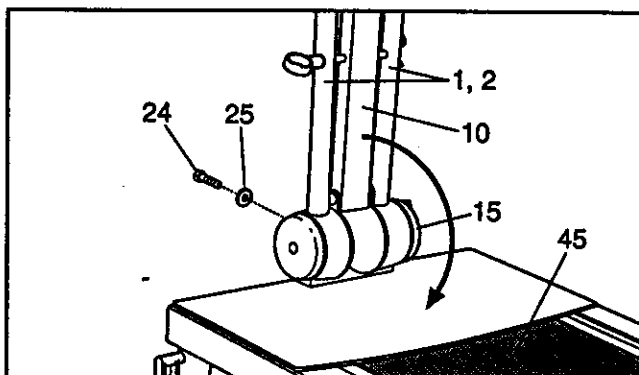

Next, remove the Upright Bolt (24) and Upright Flat Washer (25) from the Upright (10). Lay the Upright and the Upper Body Arms (1, 2) on the Walking Belt (45). Be careful not to pinch the sensor wire in the Upright. Replace the Upright Bolt and Upright Flat Washer for storage.

TROUBLE-SHOOTING

Most treadmill problems can be solved by following the simple steps below. Find the symptom that applies, and follow the steps listed. If further assistance is needed, call our toll-free HOTLINE at 1-800-736-6879, Monday through Saturday, 7 a.m. until 7 p.m. Central Time (excluding holidays).

1. SYMPTOM: THE CONSOLE DOES NOT FUNCTION PROPERLY

- a. Replace the batteries. (See BATTERY REPLACEMENT at the top of this page.)
- b. The console, like most electronics, is susceptible to static electricity build-up, caused by certain types of clothing or machine operation. If your monitor blanks out or gives false readings, an anti-static spray should be applied to the upper body arms and the upright, especially the base of the upright. Anti-static spray is available where laundry supplies are sold.
- c. Carefully tip the treadmill on its left side. Refer to the drawing at the right and locate the Reed Switch (29). Turn the Front Roller (27) until the

Magnet (51) is aligned with the Reed Switch. Loosen the Screw (5). Adjust the Reed Switch so that there is a 1/8" gap between the Reed Switch and the Magnet. Retighten the Screw.

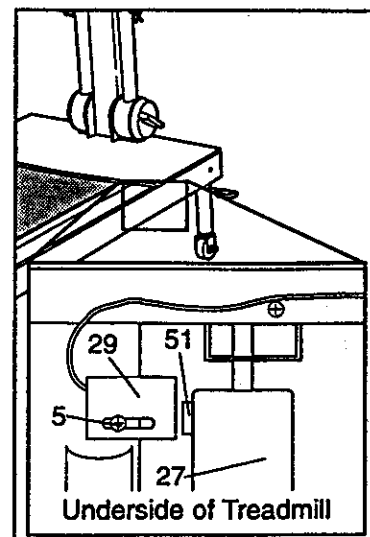

2. SYMPTOM: THE WALKING BELT DOES NOT MOVE SMOOTHLY

- a. If the Walking Belt (45) is overtightened, performance may be reduced and the Walking Belt permanently damaged.

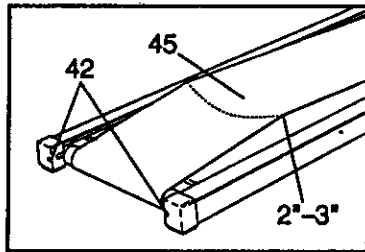

Turn the speed control fully counterclockwise. Using the included allen wrench, turn both Rear Roller Adjustment Bolts (42) counterclockwise 1/4 of a turn. When the tension of the Walking Belt is correct, you should be able to lift each side of the walking belt 2 to 3 inches; the center of the Walking Belt should just touch the surface of the walking platform. Walk on the treadmill for a few minutes. Repeat until the Walking Belt is properly tightened. Be careful to keep the Walking Belt centered.

3. SYMPTOM: THE WALKING BELT SLIPS OR IS OFF-CENTER

- a. If the Walking Belt (45) slips when walked on, use the allen wrench to turn both Rear Roller Adjustment

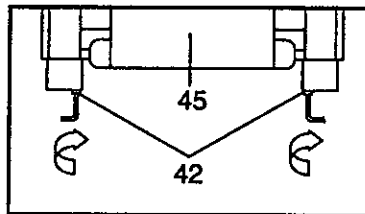

Bolts (42) clockwise, 1/4 of a turn. When the Walking Belt is correctly tightened, you should be able to lift each side of the Walking Belt 2 to 3 inches off the walking platform. The center of the Walking Belt should just touch the walking platform. Walk on the treadmill for a few minutes. Repeat until the Walking Belt is properly tightened. Be careful to keep the Walking Belt centered.

- b. If the Walking Belt (45) has shifted to the left side, use the allen wrench to turn the left Rear

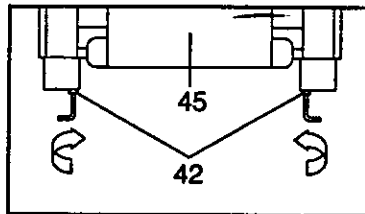

Roller Adjustment Bolt (42) clockwise, and the right Bolt counterclockwise, 1/4 of a turn each. Be careful not to overtighten the Walking Belt. Walk on the treadmill for a few minutes. Repeat until the Walking Belt is centered.

- c. If the Walking Belt (45) has shifted to the right side, use the allen wrench to turn the left Rear Roller

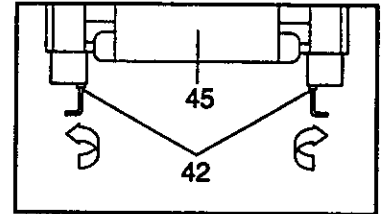

Adjustment Bolt (42) counterclockwise, and the right Bolt clockwise, 1/4 of a turn each. Be careful not to overtighten the Walking Belt. Walk on the treadmill for a few minutes. Repeat until the Walking Belt is centered.

4. SYMPTOM: THE RESISTANCE ON THE WALKING BELT DOES NOT INCREASE WHEN THE SPEED KNOB IS TURNED

- a. If the resistance on the walking belt does not increase when the speed knob is turned clockwise, the resistance belt should be tightened.

To tighten the resistance belt, first turn the speed control counterclockwise as far as it will turn.

Next, remove the four screws attaching the Hood (14). Remove the Hood and locate the Resistance Belt (67) and the Resistance Clamp (60). Open the Resistance Clamp, pull the Resistance Belt slightly tighter, and firmly close the Resistance Clamp. Reattach the Hood.

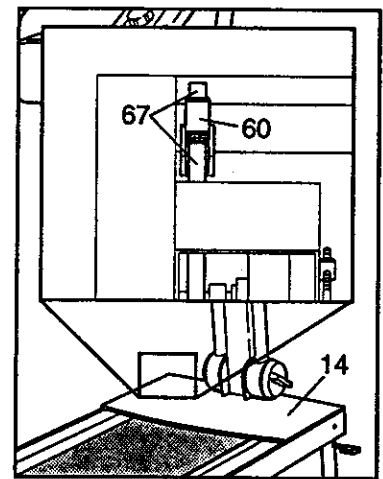

CONDITIONING GUIDELINES

The following guidelines will help you to plan your exercise program. Remember that proper nutrition and adequate rest are essential for successful results.

⚠ WARNING: Before beginning this or any exercise program, consult your physician. This is especially important for individuals over the age of 35 or individuals with pre-existing health problems.

WHY EXERCISE?

Exercise has proven essential for good health and general well-being. Regular participation in a well-rounded exercise program also results in a stronger and more efficient heart, improved respiratory function, increased stamina and endurance, better weight management and body fat control, increased ability to deal with stress, and greater self-esteem and confidence.

EXERCISE INTENSITY

To maximize the benefits of exercising, it is important to exercise with the proper intensity. The proper intensity level can be found by using your heart rate as a guide. For effective aerobic exercise, your heart rate should be maintained at a level between 70% and 85% of your maximum heart rate as you exercise. This is known as your training zone. You can find your training zone in the table below. Training zones are listed for both unconditioned and conditioned persons according to age.

AGE	TRAINING ZONE (BEATS/MIN.)	
	UNCONDITIONED	CONDITIONED
20	138-167	133-162
25	136-166	132-160
30	135-164	130-158
35	134-162	129-156
40	132-161	127-155
45	131-159	125-153
50	129-156	124-150
55	127-155	122-149
60	126-153	121-147
65	125-151	119-145
70	123-150	118-144
75	122-147	117-142
80	120-146	115-140
85	118-144	114-139

During the first few months of your exercise program, keep your heart rate near the low end of your training zone as you exercise. After a few months of regular exercise, your heart rate can be increased gradually until it is near the middle of your training zone as you exercise. To measure your heart rate, stop exercising and place two fingers on your wrist. Take a six second heartbeat count.

Multiply the result by ten to find your heart rate. (A six second count is used because your heart rate drops quickly when you stop exercising.) If your heart rate is too high, decrease the intensity of your exercise. If your heart rate is too low, increase the intensity of your exercise.

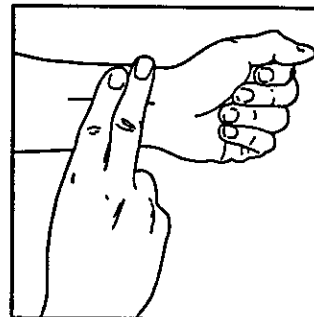

⚠ CAUTION: If you feel pain or dizziness at any time while exercising, stop immediately and begin cooling down. Consult your physician before continuing with your fitness program.

WORKOUT GUIDELINES

A well-rounded workout includes the following three phases:

A warm-up phase, lasting 5 to 10 minutes. Begin with slow, controlled stretches, and progress to more rhythmic stretches to increase body temperature, heart rate, and circulation in preparation for strenuous exercise.

A cardiovascular phase, including 20 to 30 minutes of exercising with your heart rate in your training zone.

A cool-down phase, consisting of 5 to 10 minutes of stretching. Thorough stretching offsets muscle contractions and other problems caused when you stop exercising suddenly. Stretching for increased flexibility is often most effective during this phase. This phase should leave you relaxed and comfortably tired.

To maintain or improve your condition, complete three workouts each week, with at least one day of rest between workouts. After a few months of regular exercise, you may complete up to five workouts each week, if desired. Whatever time you choose, be consistent and stick with it. Remember, the key to success is to make exercise a regular and enjoyable part of your everyday life.

PART LIST—Model No. 831.150190

R895A

Key No.	Part No.	Qty.	Description	Key No.	Part No.	Qty.	Description
1	126487	1	Left Upper Body Arm	39	108874	2	Frame Cap
2	126548	1	Right Upper Body Arm	40	124964	1	Left Endcap
3	015044	1	Hairpin Cotter	41	124965	1	Right Endcap
4	126034	8	Platform Screw	42	013206	2	Rear Roller Adjustment Bolt
5	013576	8	Screw	43	124993	2	Adjustment Plate
6	125328	10	#8 Finish Washer	44	125721	2	Foam Grip
7	124555	1	Console	45	126551	1	Walking Belt
8	126547	1	Walking Platform	46	121269	1	Friction Cover
9	125479	2	Incline Leg	47	124987	1	Pivot Bolt
10	126549	1	Upright	48	014156	1	Control Washer
11	121544	1	Lock Pin	49	109265	2	Belt Guide
12	125106	1	Flywheel Shaft	50	016028	1	Wrench Clip
13	104536	2	Eye Bolt	51	100498	1	Magnet
14	126550	1	Hood w/Decal	52	017088	1	Pad Knob
15	116693	1	Arm Resistance Control	53	123355	1	Allen Wrench
16	110193	2	Friction Bracket	54	016057	1	Cable Tie
17	014087	5	Washer	55	112013	2	Arm Cap
18	126397	2	Upper Body Arm Housing	56	125679	1	E-Ring
19	116673	2	Friction Plate	57	125355	1	Speed Control
20	125486	2	Side Trim	58	016017	1	Cable Tie Clip
21	125705	10	#8 Flat Head Screw	59	013162	1	Resistance Clamp Screw
22	125213	2	Rear Foot	60	050001	1	Resistance Clamp
23	125214	4	Rear Foot Screw	61	013326	1	Cable Adjustment Screw
24	013583	1	Upright Bolt	62	012009	2	Cable Adjustment Nut
25	014063	1	Upright Flat Washer	63	013009	1	Cable Clamp Bolt
26	122946	2	Incline Pin	64	014003	4	Cable Clamp Washer
27	126388	1	Front Roller	65	012003	1	Cable Clamp Nut
28	126389	1	Rear Roller	66	105434	1	Resistance Spring
29	125327	1	Reed Switch/Sensor Wire	67	125706	1	Resistance Belt
30	018009	2	Flywheel Bearing	68	012149	2	Incline Wheel Nut
31	014157	1	Star Washer	69	013399	2	Incline Wheel Bolt
32	125708	1	Cage Nut	70	052012	2	Incline Wheel
33	125467	1	Abdominal Pad	71	125468	1	Belt Resistance Cable
34	125154	1	Flywheel	72	125462	1	Abdominal Pad Extension
35	125191	1	Flywheel Belt	73	013020	2	Abdominal Pad Bolt
36	105496	2	Retainer	74	014126	2	Abdominal Pad Washer
37	NSP	1	Frame	75	108080	1	Reed Switch Screw
38	012139	2	Nut	#	125166	1	User's Manual

Note: “#” Indicates a non-illustrated part. Specifications are subject to change without notice. See the back cover of this manual for information about ordering replacement parts.

EXPLODED DRAWING—Model No. 831.150190

R895A

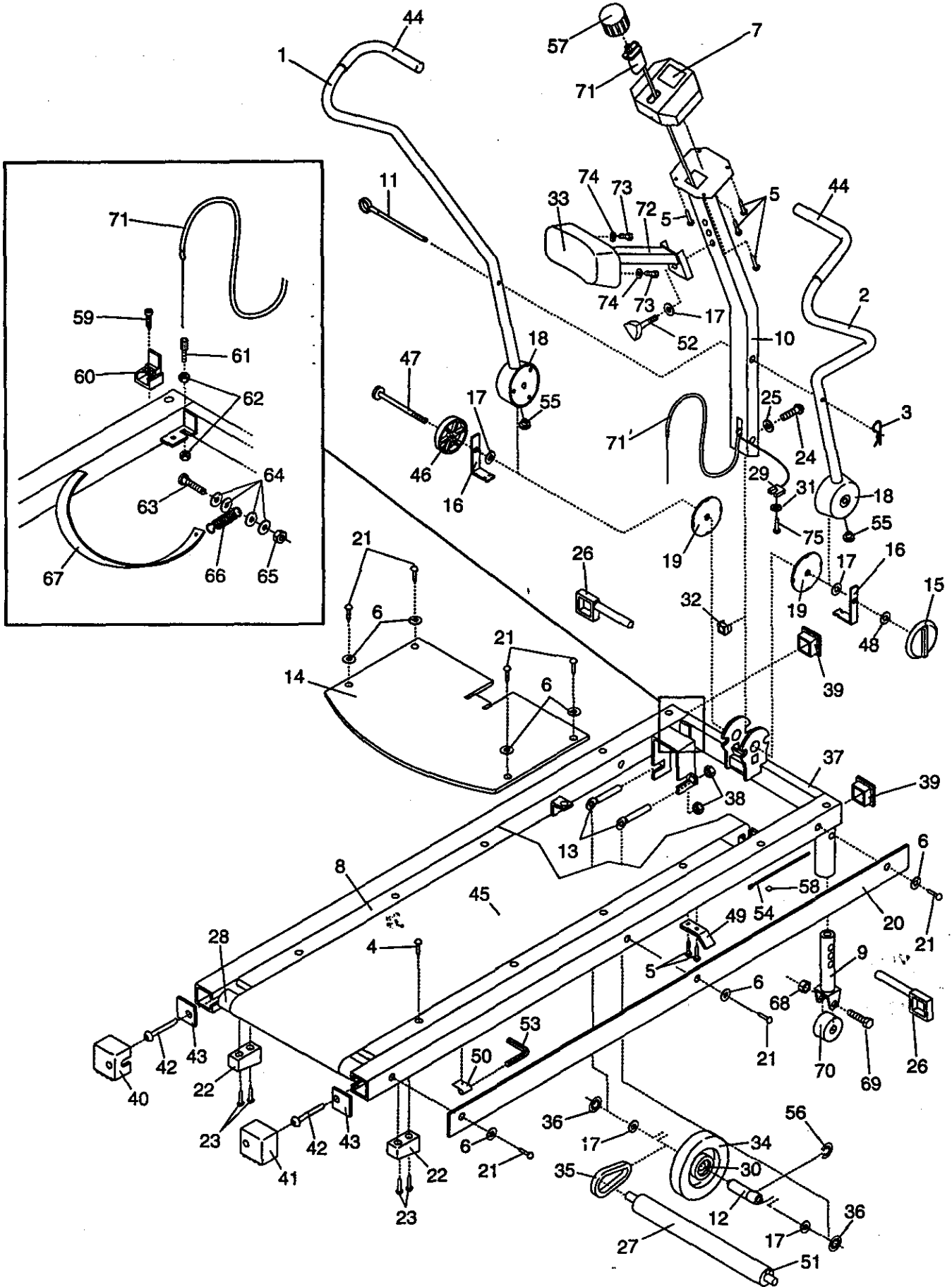

SEARS

Model No. 831.150190

QUESTIONS?

If you find that:

- you need help assembling or operating the **CARDIO WALK**
- a part is missing
- or you need to schedule repair service

call our toll-free **HELPLINE**

1-800-736-6879

Monday–Saturday, 7 am–7 pm
Central Time (excluding holidays)

REPLACEMENT PARTS

If parts become worn and need to be replaced, call the following toll-free number

1-800-FON-PART
(1-800-366-7278)

The model number and serial number of your **WESLO® CARDIO WALK** are listed on a decal attached to the frame. See the front cover of this manual to find the location of the decal.

All replacement parts are available for immediate purchase or special order when you visit your nearest **SEARS Service Center**. To request service or to order parts by telephone, call the toll-free numbers listed at the left.

When requesting help or service, or ordering parts, please be prepared to provide the following information:

- The **NAME OF THE PRODUCT** (**WESLO® CARDIO WALK**)
- The **MODEL NUMBER OF THE PRODUCT** (**831.150190**).
- The **PART NUMBER OF THE PART** (see page 10 of this manual).
- The **DESCRIPTION OF THE PART** (see page 10 of this manual).

SEARS, ROEBUCK AND CO., HOFFMAN ESTATES, IL 60179 USA

FULL 90 DAY WARRANTY

For 90 days from the date of purchase, when proper assembly and maintenance procedures detailed in the **User's Manual** are followed, **SEARS** will, free of charge, repair or replace and install a replacement part for any defective part, when the **CARDIO WALK** is used in a normal manner.

This warranty does not apply when the **CARDIO WALK** is used for commercial or rental purposes.

SERVICE IS AVAILABLE SIMPLY BY CONTACTING YOUR NEAREST SEARS SERVICE CENTER/DEPARTMENT IN THE UNITED STATES.

This warranty gives you specific legal rights, and you may also have other rights which vary from state to state.

**SEARS, ROEBUCK AND CO., DEPT. 817WA,
HOFFMAN ESTATES, IL 60179**