

PRO-FORM® 585

LOW PROFILE TREADMILL

SEARS

Model No. 831.297660

Serial No. _____

The serial number is found in the location shown below. Write the serial number in the space above for future reference.

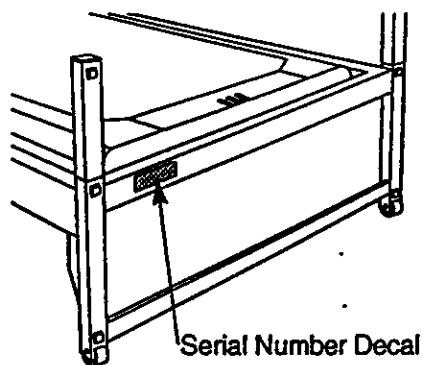

EXERCISE
EQUIPMENT

QUESTIONS

HELPLINE!

-800-736-6879

⚠ CAUTION

Read all precautions and instructions in this manual before using this equipment. Save this manual for future reference.

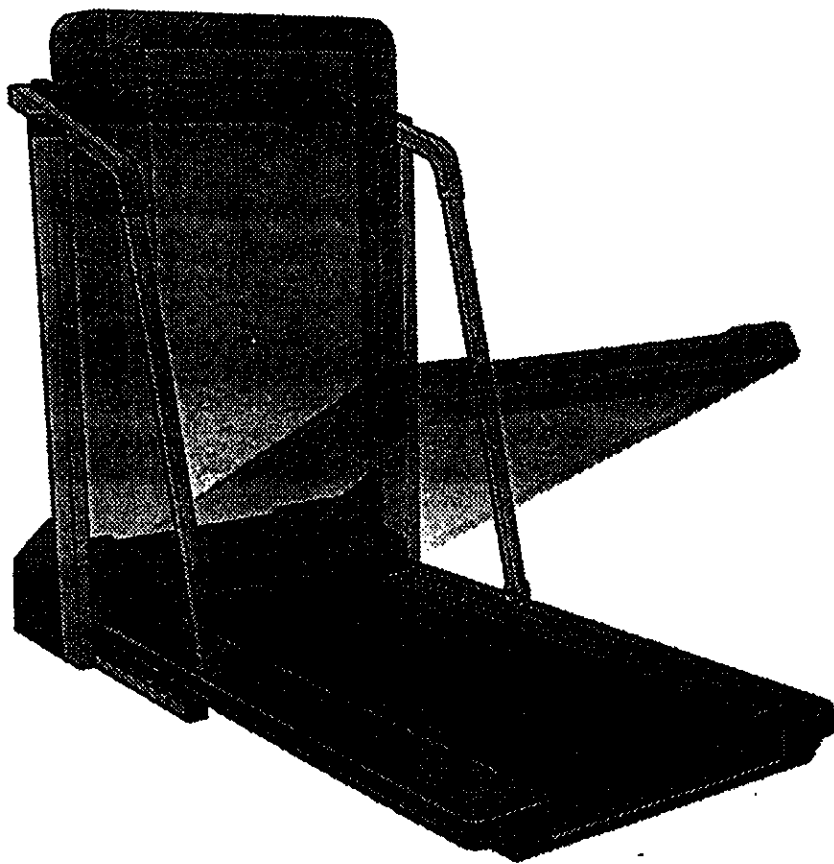

USER'S MANUAL

SEARS, ROEBUCK AND CO., HOFFMAN ESTATES, IL 60179

TABLE OF CONTENTS

FULL 90 DAY WARRANTY	2
IMPORTANT PRECAUTIONS	3
BEFORE YOU BEGIN	5
ASSEMBLY	6
OPERATION AND ADJUSTMENT	7
HOW TO FOLD AND MOVE THE TREADMILL	10
TROUBLE-SHOOTING	12
CONDITIONING GUIDELINES	14
ORDERING REPLACEMENT PARTS	Back Cover

Note: A n EXPLODED DRAWING, and a PART LIST are attached to the center of this manual. Please save them for future reference.

FULL 90 DAY WARRANTY

For 90 days from the date of purchase, if failure occurs due to defect in material or workmanship in this SEARS TREADMILL EXERCISER, contact the nearest SEARS Service Center throughout the United States and SEARS will repair or replace the TREADMILL EXERCISER, free of charge.

This warranty does not apply when the TREADMILL EXERCISER is used commercially or for rental purposes.

This warranty gives you specific legal rights, and you may also have other rights which vary from state to state.

SEARS, ROEBUCK AND CO., DEPT. 817WA, HOFFMAN ESTATES, IL 60179

IMPORTANT PRECAUTIONS

▲ WARNING: To reduce the risk of burns, fire, electric shock, or injury to persons, read the following important precautions and information before operating the treadmill.

1. It is the responsibility of the owner to ensure that all users of this treadmill are adequately informed of all warnings and precautions.
2. Use the treadmill only as described in this manual.
3. Place the treadmill on a level surface, with 8 feet of clearance behind it. Do not place the treadmill on any surface that blocks air openings. To protect the floor or carpet from damage, place a mat under the treadmill.
4. Keep the treadmill indoors, away from moisture and dust. Do not put the treadmill in a garage or covered patio, or near water.
5. Do not operate the treadmill where aerosol products are used or where oxygen is being administered.
6. Keep small children and pets away from the treadmill at all times.
7. The treadmill should be used only by persons weighing 250 pounds or less.
8. Never allow more than one person on the treadmill at a time.
9. Wear appropriate exercise clothing when using the treadmill. Do not wear loose clothing that could become caught in the treadmill. Athletic support clothes are recommended for both men and women. *Always wear athletic shoes. Never use the treadmill with bare feet, wearing only stockings, or in sandals.*
10. When connecting the power cord (see HOW TO PLUG IN THE POWER CORD on page 7), plug the power cord into a surge protector (not included) and plug the surge protector into a grounded circuit capable of carrying 15 or more amps. No other appliance should be on the same circuit.
11. Use only a UL-listed surge protector, rated at 15 amps, with a 14-gauge cord of five feet or less in length. Do not use an extension cord.
12. Keep the power cord and the surge protector away from heated surfaces.
13. Never move the walking belt while the power is turned off. Do not operate the treadmill if the power cord or plug is damaged, or if the treadmill is not working properly. (See BEFORE YOU BEGIN on page 5 if the treadmill is not working properly.)
14. Never start the treadmill while you are standing on the walking belt. Always hold the handrails while using the treadmill.
15. The treadmill is capable of high speeds. Adjust the speed in small increments to avoid sudden jumps in speed.
16. To reduce the possibility of the treadmill overheating, do not operate the treadmill continuously for longer than 1 hour.
17. The pulse sensor is not a medical device. Various factors, including the user's movement, may affect the accuracy of heart rate readings. The pulse sensor is intended only as an exercise aid in determining heart rate trends in general.
18. Never leave the treadmill unattended while it is running.
19. Do not attempt to raise, lower, or move the treadmill until it is properly assembled. (See ASSEMBLY on page 6, and HOW TO MOVE THE TREADMILL on page 11.) You must be able to safely lift 45 pounds (20 kg) to raise, lower, or move the treadmill.
20. When folding or moving the treadmill, make sure that the storage latch is fully closed.
21. Inspect and tighten all parts of the treadmill every three months.
22. Never insert any object into any opening.

23. Always unplug the power cord before performing the maintenance and adjustment procedures described in this manual. Never remove the motor hood unless instructed to do so by an authorized service representative. Servicing other than the procedures in

this manual should be performed by an authorized service representative only.

24. This treadmill is intended for in-home use only. Do not use this treadmill in any commercial, rental, or institutional setting.

⚠ WARNING: Before beginning this or any exercise program, consult your physician. This is especially important for persons over the age of 35 or persons with pre-existing health problems. Read all instructions before using. SEARS assumes no responsibility for personal injury or property damage sustained by or through the use of this product.

SAVE THESE INSTRUCTIONS

⚠ WARNING!

- Never allow children to play on or around treadmill.
- Storage latch must be fully engaged before treadmill is moved or stored.

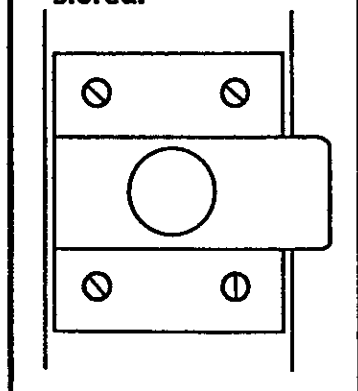

The decals shown have been placed on your treadmill. If a decal is missing, or if it is not legible, please call our toll-free HELPLINE to order a free replacement decal (see the back cover of this manual). Apply the decals in the location shown.

IMPORTANT: *Incline must be set at lowest level before folding treadmill into storage position.*

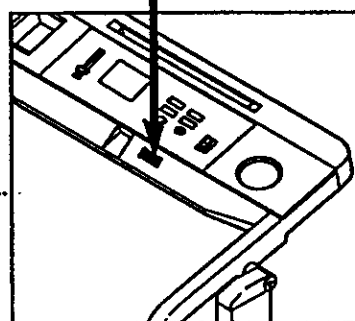
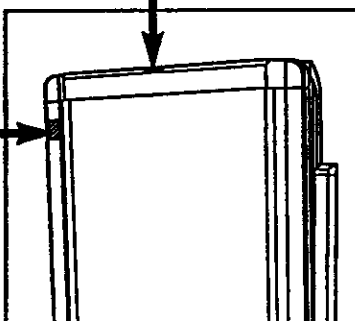

BEFORE YOU BEGIN

Thank you for selecting the PROFORM® 585 TL treadmill. The 585 TL treadmill blends advanced technology with innovative design to let you enjoy an excellent form of cardiovascular exercise in the convenience and privacy of your home.

For your benefit, read this manual carefully before using the treadmill. If you have additional questions, please call our toll-free HELPLINE at 1-800-736-6879, Monday through Saturday, 7 a.m. until 7 p.m. Central

Time (excluding holidays). To help us assist you, please note the product model number and serial number before calling. The model number of the treadmill is 831.297660. The serial number can be found on a decal attached to the treadmill (see the front cover of this manual for the location).

Before reading further, please review the drawing below and familiarize yourself with the parts that are labeled.

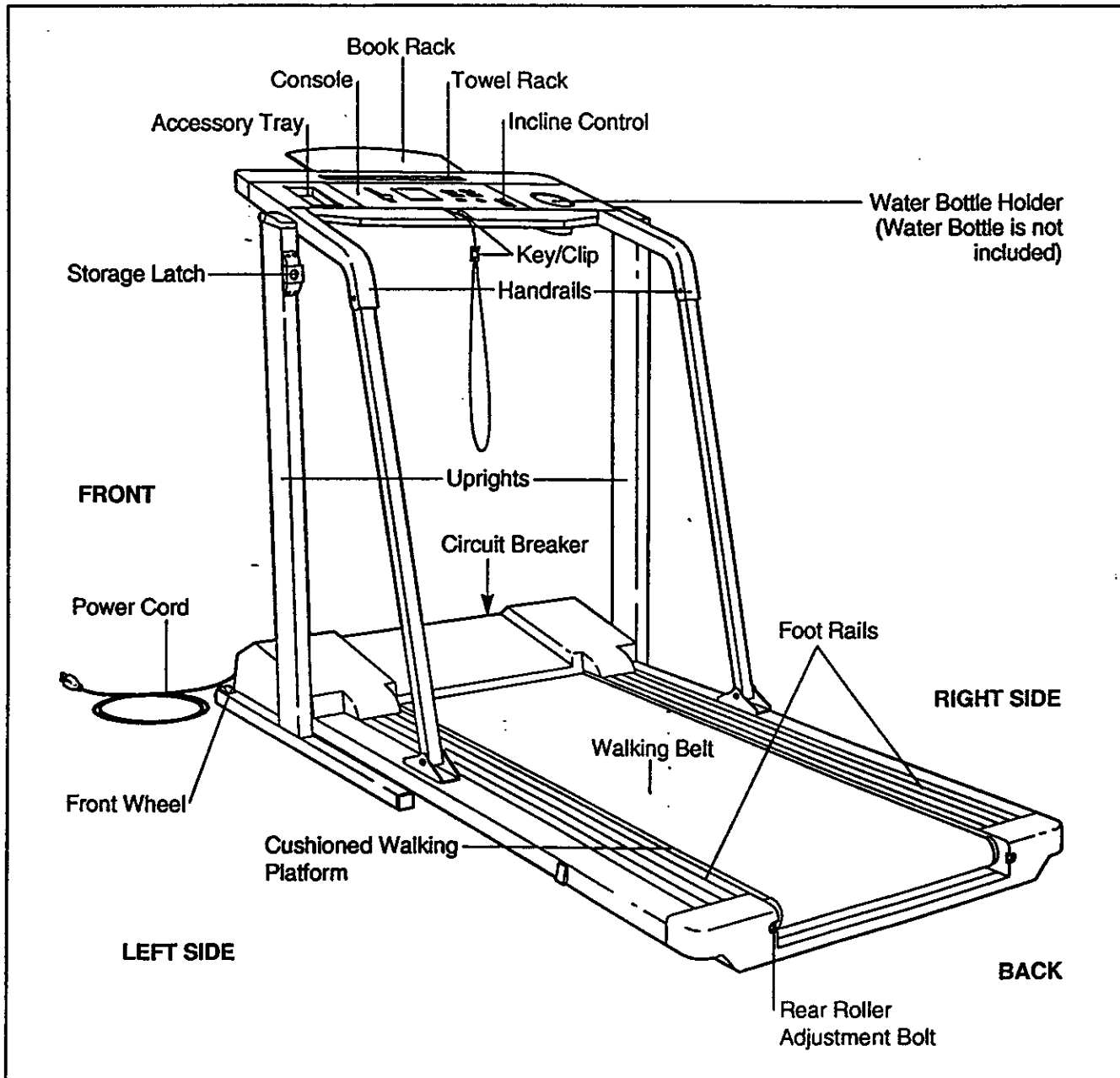

ASSEMBLY

Assembly requires two people. Set the treadmill in a cleared area and remove the packing materials. Do not dispose of the packing materials until assembly is completed. Assembly requires the Included allen wrench

1. With the help of a second person, carefully turn the treadmill onto its right side as shown.

Firmly slide a Base Extension (76) into one side of the Base (86). Using the Allen Wrench (89), tighten an Extension Bolt (13) into the Base Extension and the Base.

Attach the other Base Extension (not shown) in the same manner.

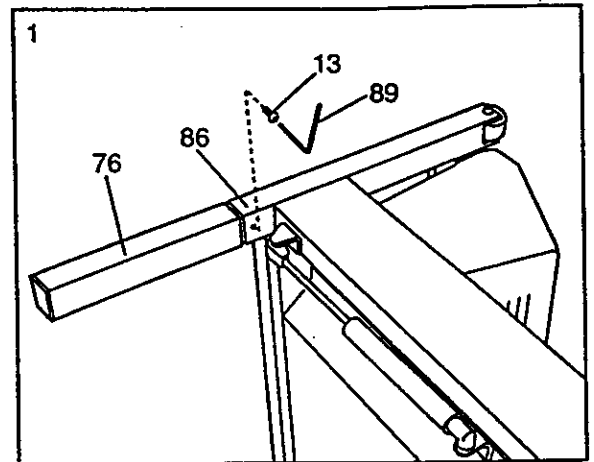

2. Attach six Base Pads (43) to the Base (86) and the Base Extensions (76) in the indicated locations. Note: An extra Base Pad may be included.

With the help of a second person, carefully raise the treadmill to the upright position so the Base (86) and the Base Extensions (76) are resting on the floor.

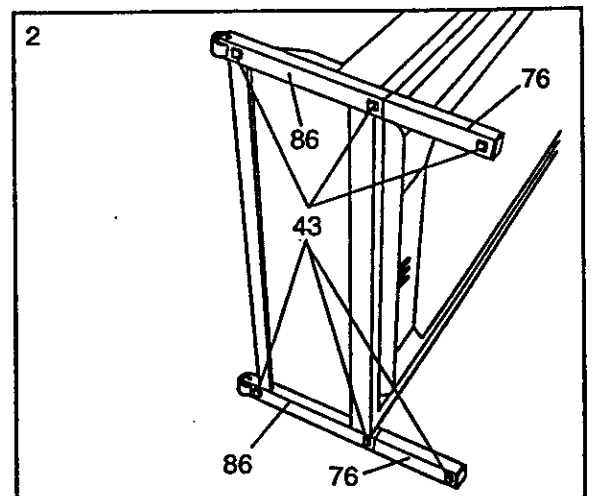

3. Align the holes in the Book Rack (101) with the holes in the Console Base (85). Attach the Book Rack with the four Console Screws (6) as shown.

Refer to HOW TO LOWER THE TREADMILL FOR USE on page 11. Follow the instructions to lower the treadmill.

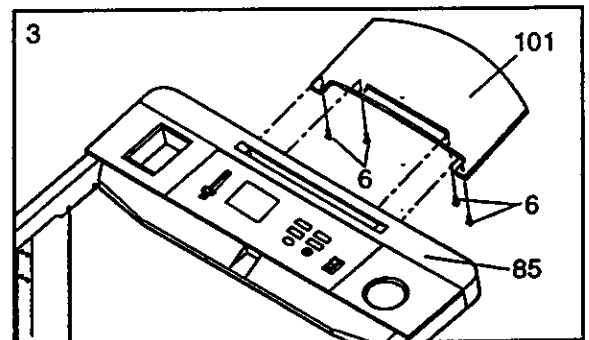

4. Remove the backing from the Adhesive Clip (90). Press the Adhesive Clip onto the Rear Roller Cover (82) in the indicated location. Press the Allen Wrench (89) into the Adhesive Clip.

Make sure that all parts are tightened before you use the treadmill. Note: To protect the floor or carpet, place a mat under the treadmill. For information on ordering a mat, see REPLACEMENT PARTS on the back cover.

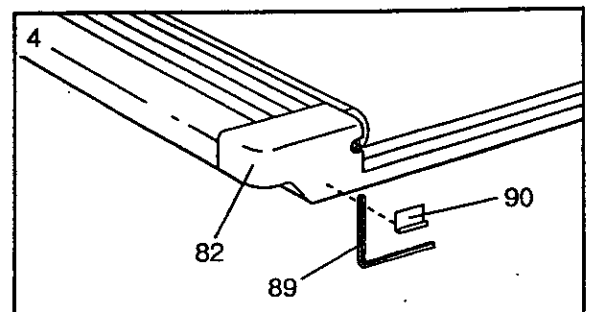

OPERATION AND ADJUSTMENT

THE PERFORMANT LUBE™ WALKING BELT

Your treadmill features a walking belt coated with PERFORMANT LUBE™, a high-performance lubricant. **IMPORTANT:** Never apply silicone spray or other substances to the walking belt or the walking platform. They will deteriorate the walking belt and cause excessive wear.

HOW TO PLUG IN THE POWER CORD

⚠ DANGER: Improper connection of the equipment-grounding conductor can result in an increased risk of electric shock. Check with a qualified electrician or serviceman if you are in doubt as to whether the product is properly grounded. Do not modify the plug provided with the product—If it will not fit the outlet, have a proper outlet installed by a qualified electrician.

Your treadmill, like any other type of sophisticated electronic equipment, can be seriously damaged by sudden voltage changes in your home's power. Voltage surges, spikes, and noise interference can result from weather conditions or from other appliances being turned on or off. **To decrease the possibility of your treadmill being damaged, always use a surge protector (not included) with your treadmill.**

Surge protectors are sold at most hardware stores and department stores. Use only a UL-listed surge protector, rated at 15 amps, with a 14-gauge cord of five feet or less in length.

This product must be grounded. If it should malfunction or break down, grounding provides a path of least resistance for electric current to reduce the risk of

electric shock. This product is equipped with a cord having an equipment-grounding conductor and a grounding plug. Plug the power cord into a surge protector, and plug the surge protector into an appropriate outlet that is properly installed and grounded in accordance with all local codes and ordinances.

This product is for use on a nominal 120-volt circuit, and has a grounding plug that looks like the plug illustrated in drawing 1 below. A temporary adapter that looks like the adapter illustrated in drawing 2 may be used to connect the surge protector to a 2-pole receptacle as shown in drawing 2 if a properly grounded outlet is not available.

The temporary adapter should be used only until a properly grounded outlet (drawing 1) can be installed by a qualified electrician.

The green-colored rigid ear, lug, or the like extending from the adapter must be connected to a permanent ground such as a properly grounded outlet box cover. Whenever the adapter is used it must be held in place by a metal screw. Some 2-pole receptacle outlet box covers are not grounded. Contact a qualified electrician to determine if the outlet box cover is grounded before using an adapter.

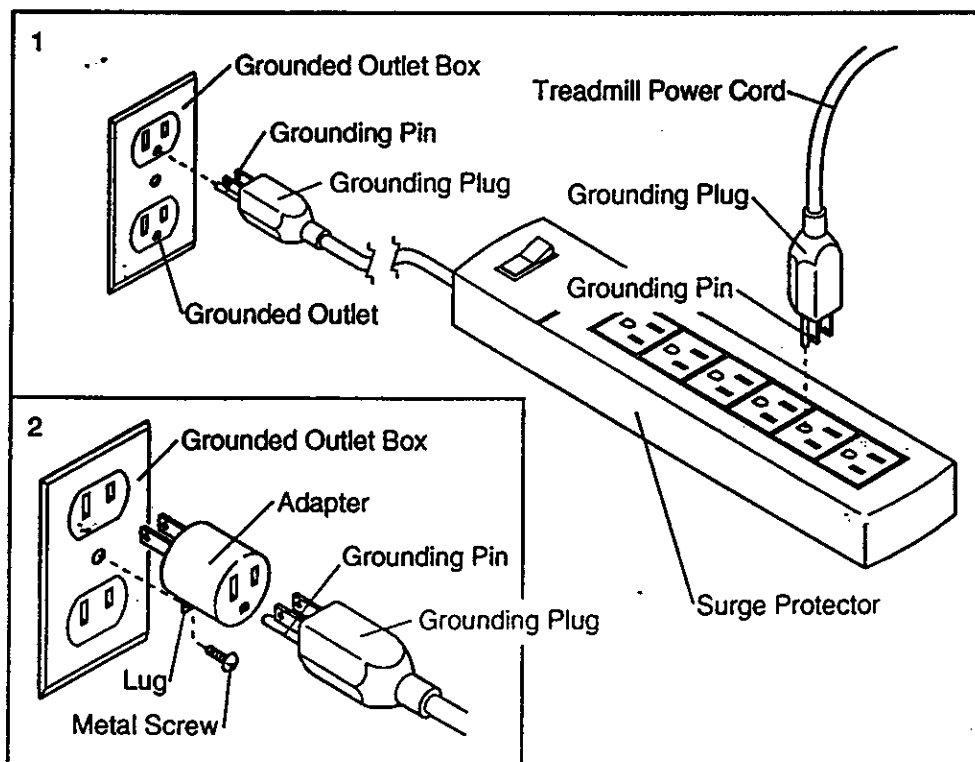
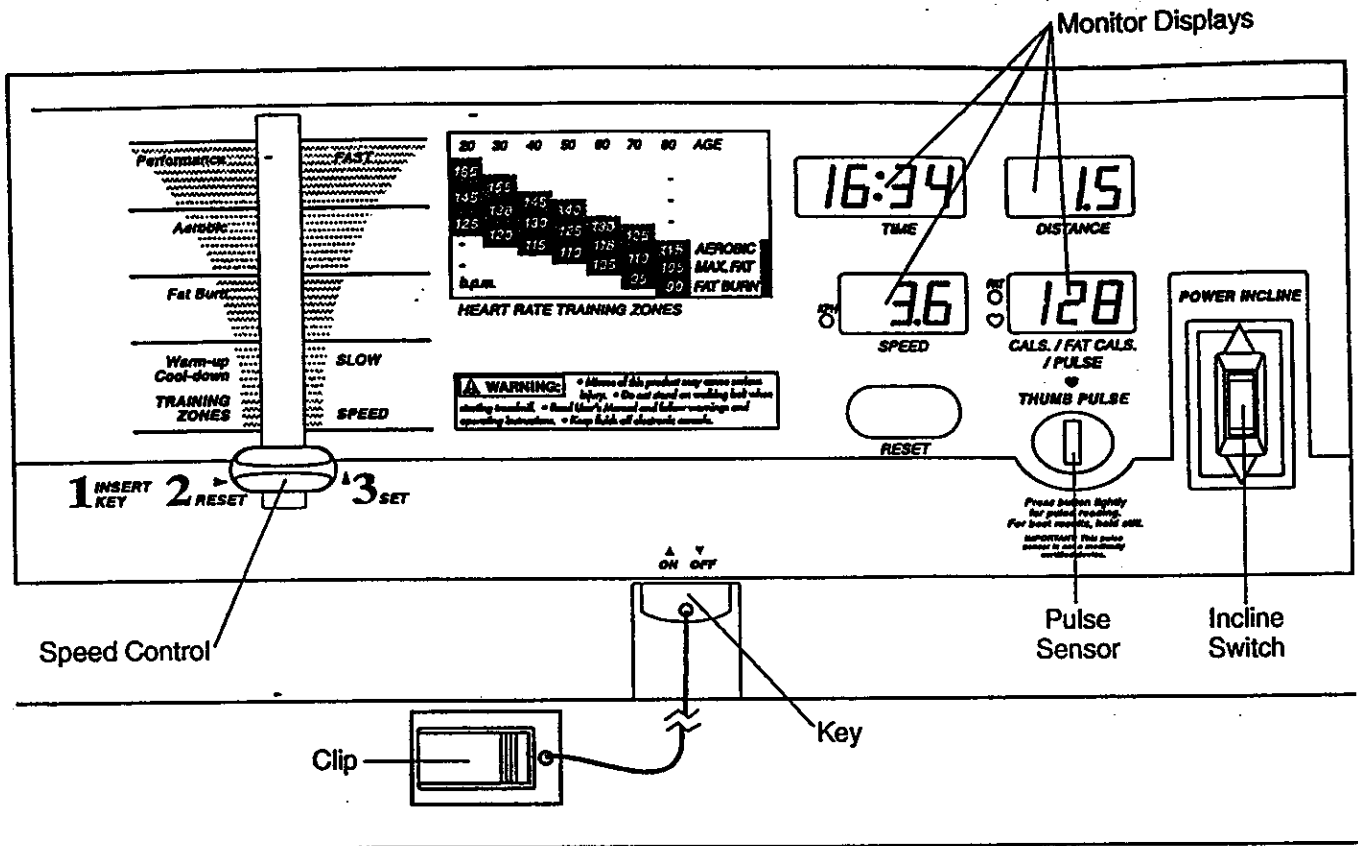

DIAGRAM OF THE CONSOLE



CAUTION: Before operating the console, read the following precautions.

- Do not stand on the walking belt when turning on the power.
- Always wear the clip (see the drawing above) while using the treadmill. When the key is removed from the console, the walking belt will stop.
- Adjust the speed in small increments.
- The training zones marked beside the speed control are general guidelines only. See pages 14 and 15 for more information.
- To reduce the possibility of electric shock, keep the console dry. Avoid spilling liquids on the console. Use only a sealed water bottle.

STEP BY STEP CONSOLE OPERATION

Before operating the console, make sure that the power cord is properly plugged in. (See HOW TO PLUG IN THE POWER CORD on page 7.) If there is a thin sheet of clear plastic on the face of the console, remove it.

Next, step onto the foot rails of the treadmill. Find the clip attached to the key (see the drawing above), and slide the clip onto the waistband of your clothing.

Follow the steps on pages 8 and 9 to operate the console.

1 Insert the key fully into the power switch.

Inserting the key will not turn on the displays. The displays will turn on when the RESET button is pressed or when the walking belt is started.

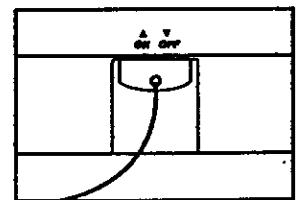

2 Reset the speed control.

Slide the speed control down to the RESET position. Note: Each time the walking belt is stopped, the speed control must be moved to the RESET position before the walking belt can be restarted.

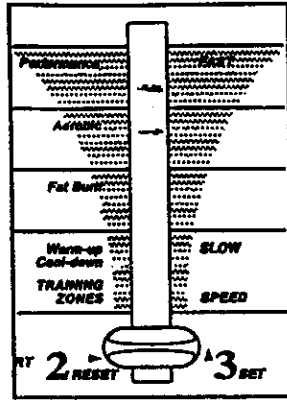

3 Start the walking belt.

After you have moved the speed control to the RESET position, slowly slide it upward until the walking belt begins to move at slow speed. Carefully step onto the walking belt and begin exercising. Change the speed of the walking belt as desired by sliding the speed control.

To stop the walking belt, step onto the foot rails and slide the speed control to the RESET position.

4 Follow your progress with the monitor displays.

TIME display—This display shows the total time that you have walked or run on the treadmill.



DISTANCE display—This display shows the total distance that you have walked or run. If the KPH indicator beside the SPEED display is lit, the distance will be displayed in kilometers. If the indicator is not lit, the distance will be displayed in miles.



SPEED display—This display shows the speed of the walking belt, in miles per hour or kilometers per hour. The KPH indicator will light when the speed is displayed in kilometers per hour:

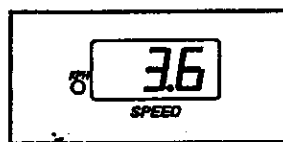

To change the unit of measurement, hold down the RESET button for seven seconds. The KPH indicator will show which unit of measurement is selected.

CALORIES/FAT CALORIES/PULSE display—This display shows the approximate numbers of calories and fat calories you have burned. (See FAT BURNING on page 14 for an explanation of fat calories.) Every seven seconds, the display will change from one number to the other. The FAT indicator will light when the number of fat calories is displayed. Note: This display will also show your pulse when the pulse sensor is used.

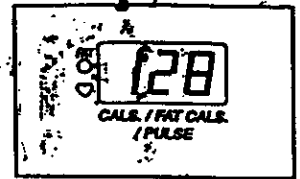

The displays can be reset, if desired, by pressing the RESET button.

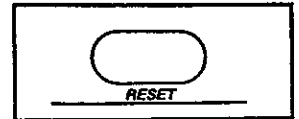

5 Measure your pulse, if desired.

To use the pulse sensor, stand on the foot rails and place your thumb on the pulse sensor as shown.

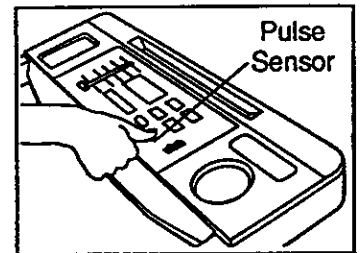

The pulse sensor is pressure-activated; fully press down the pulse sensor. Do not press too hard, or the circulation in your thumb will be restricted, and your pulse will not be detected. Next, slightly raise your thumb until the heart-shaped indicator by the CALORIES/ FAT CALORIES/PULSE display flashes steadily. Hold your thumb at this level. After 5 to 10 seconds, your pulse will be shown. Hold your thumb on the sensor for another 15 seconds for the most accurate reading. If the displayed pulse appears to be too high or too low, or if your pulse is not displayed, lift your thumb off the sensor and allow the display to reset. Press down again on the sensor as described above.

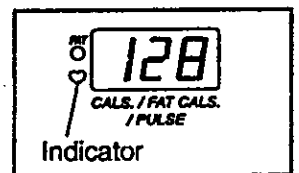

Make sure that your thumb is positioned as shown, and that you are applying the proper amount of pressure to the pulse sensor. Try the sensor several times until you become familiar with it. Remember to stand still while measuring your pulse.

6 Change the incline of the treadmill, if desired.

To increase or decrease the incline, hold down the top or bottom of the incline button. **Important:** Do not change the incline of the treadmill by placing objects under the treadmill. Change the incline only as described above.

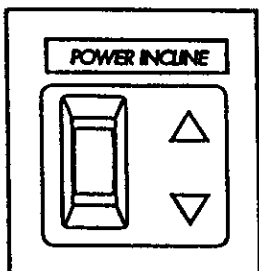

Important: Before folding the treadmill, adjust the incline to the lowest position.

7 When you are finished exercising, stop the walking belt and remove the key.

Step onto the foot rails, stop the walking belt, and remove the key from the console. Store the key in a secure place. After the key is removed, the displays will remain on for about five minutes.

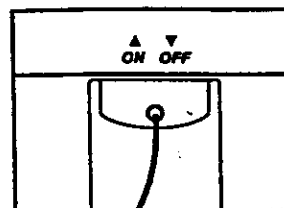

Note: Any time that the walking belt is stopped and no console buttons are pressed for five minutes, the displays will automatically turn off.

HOW TO FOLD AND MOVE THE TREADMILL

HOW TO FOLD THE TREADMILL FOR STORAGE

Before folding the treadmill, adjust the incline to the lowest position. If the incline is not at the lowest position, the treadmill will be permanently damaged. Next, unplug the power cord. **Caution:** You must be able to safely lift 45 pounds (20 kg) in order to raise, lower, or move the treadmill.

1. Hold the treadmill with your hands in the locations shown at the right. **Caution:** To avoid pinching your hands, do not hold the treadmill in the locations indicated by the arrows. To decrease the possibility of injury, bend your legs and keep your back straight. As you raise the treadmill, make sure to lift with your legs rather than your back. Raise the treadmill about halfway to the vertical position.

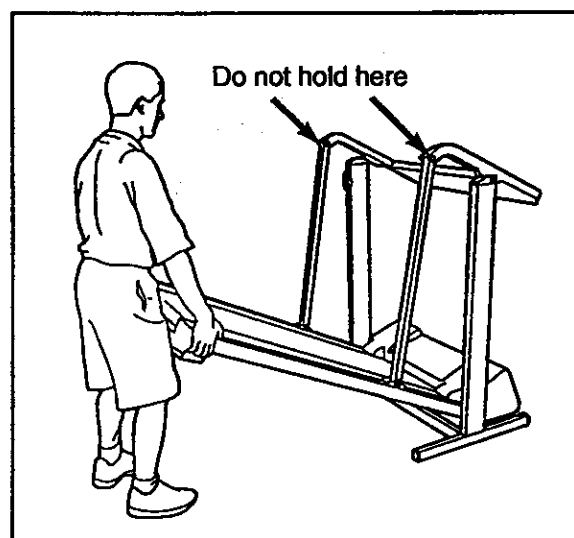

2. Move your right hand to the position shown and hold the treadmill firmly. Raise the treadmill until the storage latch closes over the frame guide. Make sure that the storage latch closes fully over the frame guide.

To protect the floor or carpet from damage, place a mat under the treadmill. Keep the treadmill out of direct sunlight. Do not leave the treadmill in the storage position in temperatures above 85° Fahrenheit.

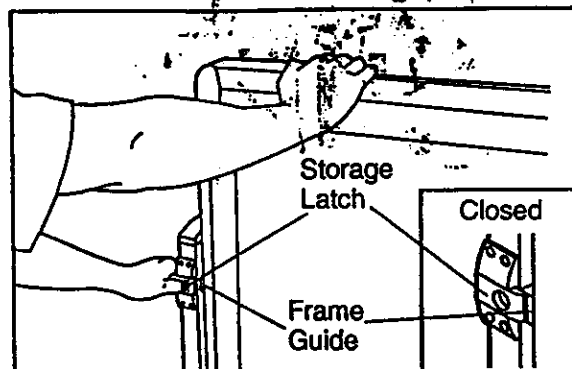

HOW TO MOVE THE TREADMILL

Before moving the treadmill, convert the treadmill to the storage position as described above. Make sure that the storage latch is closed fully over the frame guide.

1. Hold the upper ends of the treadmill. Place one foot on the base as shown.
2. Tilt the treadmill back until it rolls freely on the front wheels. Carefully move the treadmill to the desired location. Never move the treadmill without tipping it back, or the base pads may come off. To reduce the risk of injury, use extreme caution while moving the treadmill. Do not attempt to move the treadmill over an uneven surface.
3. Place one foot on the base, and carefully lower the treadmill until it is resting in the storage position.



HOW TO LOWER THE TREADMILL FOR USE

1. Hold the upper end of the treadmill with your right hand as shown. Using your left thumb, slide open the storage latch and hold it open. Pivot the treadmill until the frame is past the storage latch.

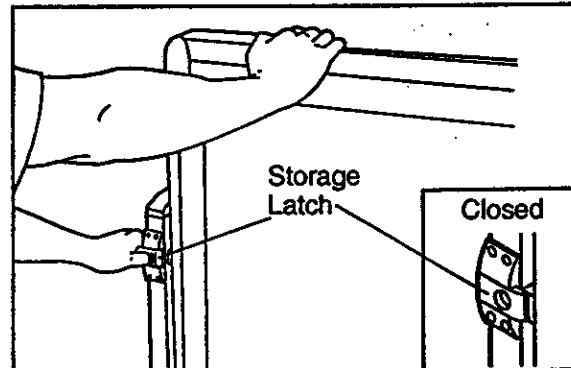

2. Hold the treadmill firmly with both hands, and lower the treadmill to the floor. To decrease the possibility of injury, bend your legs and keep your back straight.

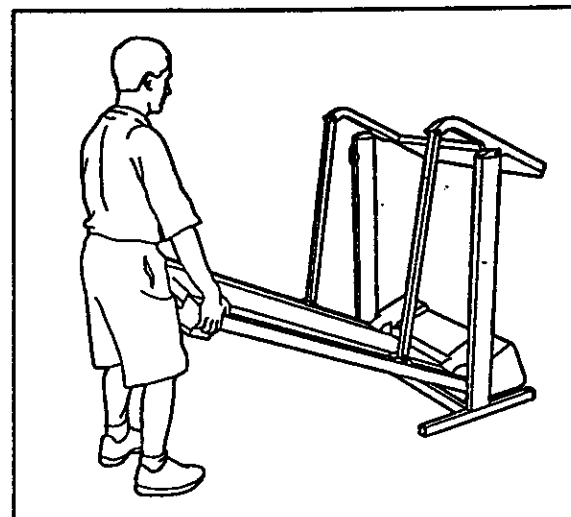

TROUBLE-SHOOTING

Most treadmill problems can be solved by following the simple steps below. Find the symptom that applies, and follow the steps listed. If further assistance is needed, call our toll-free HELPLINE at 1-800-736-6879, Monday through Saturday, 7 a.m. until 7 p.m. Central Time (excluding holidays).

1. SYMPTOM: THE POWER DOES NOT TURN ON

- Make sure that the power cord is plugged into a surge protector, and that the surge protector is plugged into a properly grounded outlet. (See HOW TO PLUG IN THE POWER CORD on page 7.) Use only a UL-listed surge protector, rated at 15 amps, with a 14-gauge cord of five feet or less in length.
- After the power cord has been plugged in, make sure that the key is fully inserted into the console. (See step 1 on page 8.)
- Check the circuit breaker located on the treadmill near the power cord. If the switch protrudes as shown, the circuit breaker has tripped. To reset the circuit breaker, wait for five minutes and then press the switch back in.

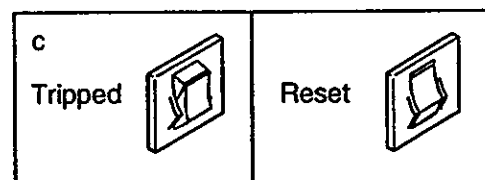

2. SYMPTOM: THE POWER TURNS OFF DURING USE

- Check the circuit breaker located on the treadmill frame near the power cord (see 1. c. above). If the circuit breaker has tripped, wait for five minutes and then press the switch back in.
- Make sure that the power cord is plugged in.
- Remove the key from the console. Reinsert the key fully into the console. (See step 1 on page 8.)
- If the treadmill still will not run, please call our toll-free HELPLINE.

3. SYMPTOM: THE WALKING BELT SLOWS WHEN WALKED ON

- Use only a UL-listed surge protector, rated at 15 amps, with a 14-gauge cord of five feet or less in length.
- If the walking belt still slows when walked on, please call our toll-free HELPLINE.

4. SYMPTOM: THE WALKING BELT IS OFF-CENTER WHEN WALKED ON

- If the walking belt has shifted to the left, first remove the key and **UNPLUG THE POWER CORD**. Using the allen wrench, turn the left rear roller adjustment bolt clockwise 1/4 of a turn. Plug in the power cord, insert the key and run the treadmill for a few minutes. Repeat until the walking belt is centered.

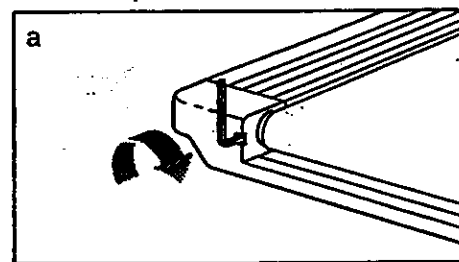

- If the walking belt has shifted to the right, first remove the key and **UNPLUG THE POWER CORD**. Using the allen wrench, turn the left rear roller adjustment bolt counterclockwise 1/4 of a turn. Plug in the power cord, insert the key and run the treadmill for a few minutes. Repeat until the walking belt is centered.

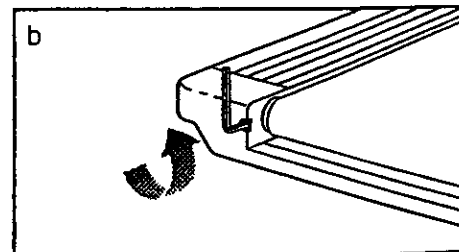

5. SYMPTOM: THE TREADMILL SITS UNEVENLY ON THE FLOOR

- a. Make sure that the six base pads are attached to the treadmill (see assembly step 2 on page 6).

CONDITIONING GUIDELINES

⚠ WARNING: Before beginning this or any exercise program, consult your physician. This is especially important for individuals over the age of 35 or individuals with pre-existing health problems.

The pulse sensor is not a medical device. Various factors, including your movement, may affect the accuracy of heart rate readings. The sensor is intended only as an exercise aid in determining heart rate trends in general.

The following guidelines will help you to plan your exercise program. Remember—these are general guidelines only. For more detailed exercise information, obtain a reputable book or consult your physician.

EXERCISE INTENSITY

Whether your goal is to burn fat or to strengthen your cardiovascular system, the key to achieving the desired results is to exercise with the proper intensity. The proper intensity level can be found by using your heart rate as a guide. The chart below shows recommended heart rates for fat burning and aerobic exercise.

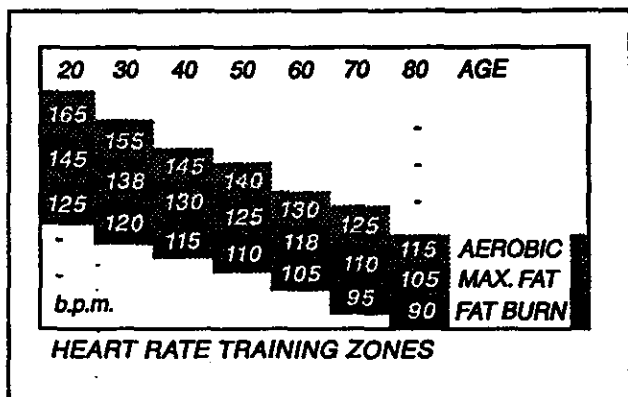

To find the proper heart rate for you, first find your age at the top of the chart (ages are rounded off to the nearest ten years). Next, find the three numbers below your age. The three numbers are your "training zone." The lower two numbers are recommended heart rates for fat burning; the higher number is the recommended heart rate for aerobic exercise.

Fat Burning

To burn fat effectively, you must exercise at a relatively low intensity level for a sustained period of time. During the first few minutes of exercise, your body uses easily

accessible *carbohydrate calories* for energy. Only after the first few minutes does your body begin to use stored *fat calories* for energy. If your goal is to burn fat, adjust the speed and incline of the treadmill until your heart rate is near one of the lower two numbers in your training zone. It may also be helpful to set the speed control on the console to FAT BURN to help you maintain the proper intensity level. (See page 9.)

Aerobic Exercise

If your goal is to strengthen your cardiovascular system, your exercise must be "aerobic." Aerobic exercise is activity that requires large amounts of oxygen for prolonged periods of time. This increases the demand on the heart to pump blood to the muscles, and on the lungs to oxygenate the blood. For aerobic exercise, adjust the speed and incline of the treadmill until your heart rate is near the higher number in your training zone. It may also be helpful to set the speed control on the console to AEROBIC to help you maintain the proper intensity level. (See page 9.)

High Performance Athletic Conditioning

If your goal is high performance athletic conditioning, set the speed control on the console to PERFORMANCE to help you maintain the proper intensity level. (See page 9.) Note: During the first few weeks of your exercise program, keep your heart rate near the low end of your training zone.

To measure your heart rate during exercise, use the pulse sensor on the console. (See page 9.) If your heart rate is too high or too low, adjust the speed or incline of the treadmill as needed.

WORKOUT GUIDELINES

Each workout should include the following three parts:

A Warm-up

Start each workout with 5 to 10 minutes of stretching and light exercise. A proper warm-up increases your body temperature, heart rate, and circulation in preparation for strenuous exercise.

Training Zone Exercise

After warming up, increase the intensity of your exercise until your heart rate is in your training zone for 20 to 60 minutes. (During the first few weeks of your exercise program, do not keep your heart rate in your training zone for longer than 20 minutes.) Breathe regularly and deeply as you exercise—never hold your breath.

A Cool-down

Finish each workout with 5 to 10 minutes of stretching to cool down. This will increase the flexibility of your muscles and will help to prevent post-exercise problems.

Exercise Frequency

To maintain or improve your condition, complete three workouts each week, with at least one day of rest between workouts. After a few months of regular exercise, you may complete up to five workouts each week if desired. *The key to success is to make exercise a regular and enjoyable part of your everyday life.*

SUGGESTED STRETCHES

The correct form for several basic stretches is shown in the drawings below. Move slowly as you stretch—never bounce.

1. Toe Touch Stretch

Stand with your knees bent slightly and slowly bend forward from your hips. Allow your back and shoulders to relax as you reach down toward your toes as far as possible. Hold for 15 counts, then relax. Repeat 3 times. Stretches: Hamstrings, back of knees and back.

2. Hamstring Stretch

Sit with one leg extended. Bring the sole of the opposite foot toward you and rest it against the inner thigh of your extended leg. Reach toward your toes as far as possible. Hold for 15 counts, then relax. Repeat 3 times for each leg. Stretches: Hamstrings, lower back and groin.

3. Calf/Achilles Stretch

With one leg in front of the other, reach forward and place your hands against a wall. Keep your back leg straight and your back foot flat on the floor. Bend your front leg, lean forward and move your hips toward the wall. Hold for 15 counts, then relax. Repeat 3 times for each leg. To cause further stretching of the achilles tendons, bend your back leg as well. Stretches: Calves, achilles tendons and ankles.

4. Quadriceps Stretch

With one hand against a wall for balance, reach back and grasp one foot with your other hand. Bring your heel as close to your buttocks as possible. Hold for 15 counts, then relax. Repeat 3 times for each leg. Stretches: Quadriceps and hip muscles.

5. Inner Thigh Stretch

Sit with the soles of your feet together and your knees outward. Pull your feet toward your groin area as far as possible. Hold for 15 counts, then relax. Repeat 3 times. Stretches: Quadriceps and hip muscles.

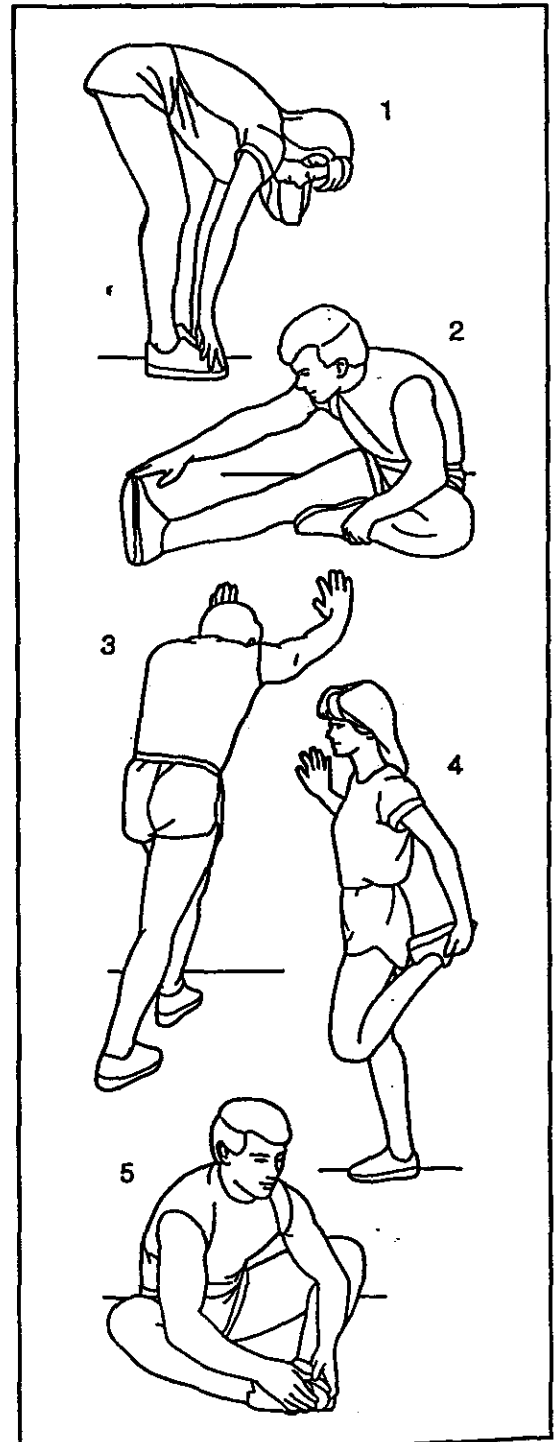

REMOVE THIS EXPLODED DRAWING AND PART LIST FROM THE MANUAL

Keep this EXPLODED DRAWING and PART LIST for future reference.

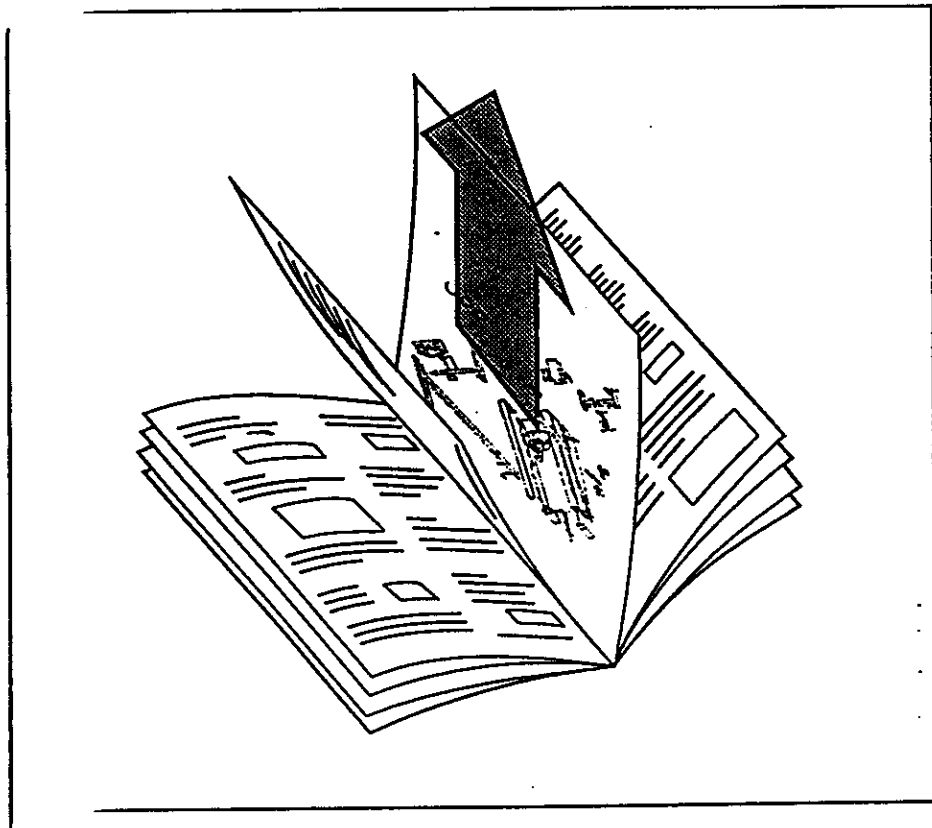

Specifications are subject to change without notice. For information about
obtaining replacement parts, see the back cover of the User's Manual.

EXPLODED DRAWING—Model No. 831.297660

R1096B

101

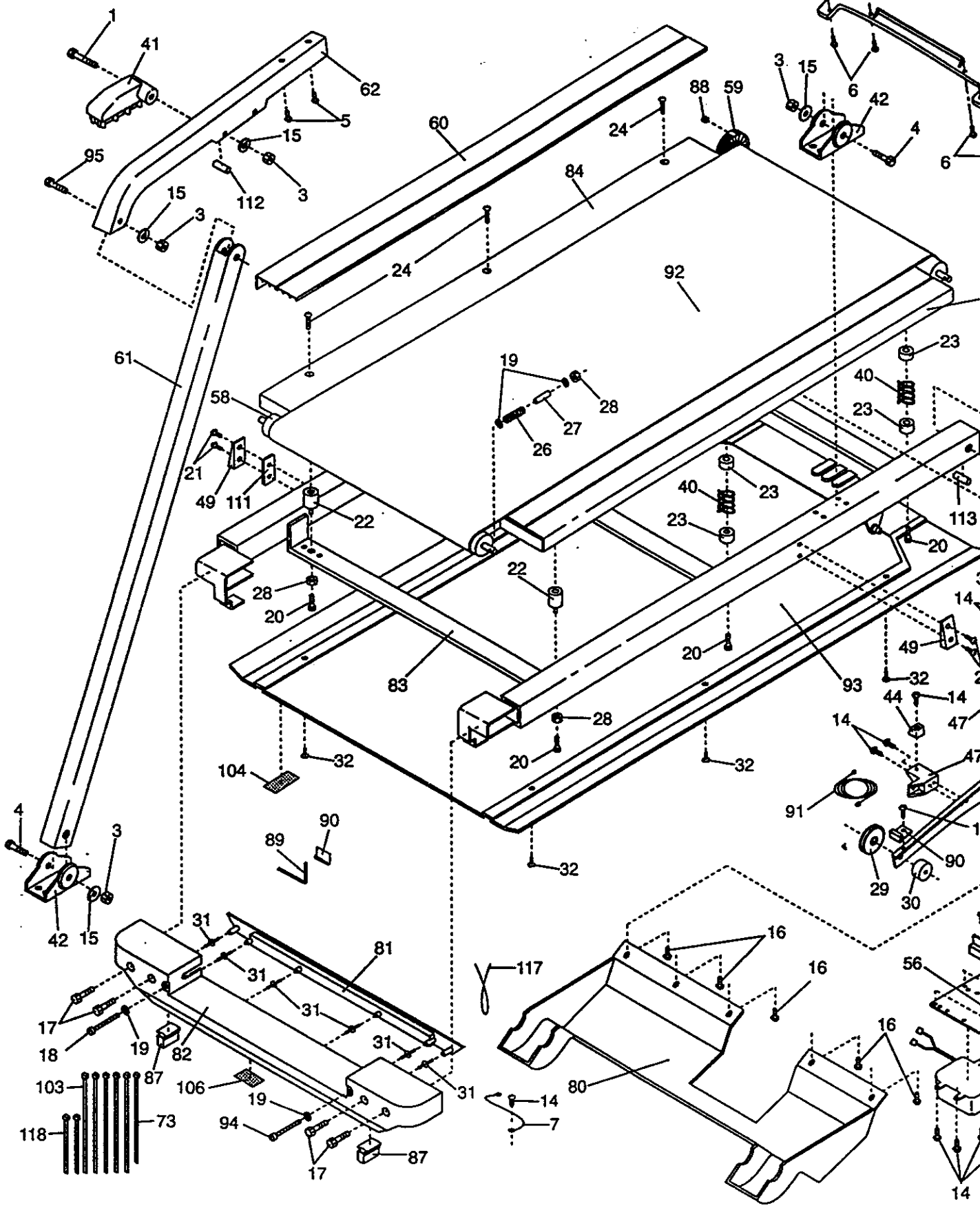

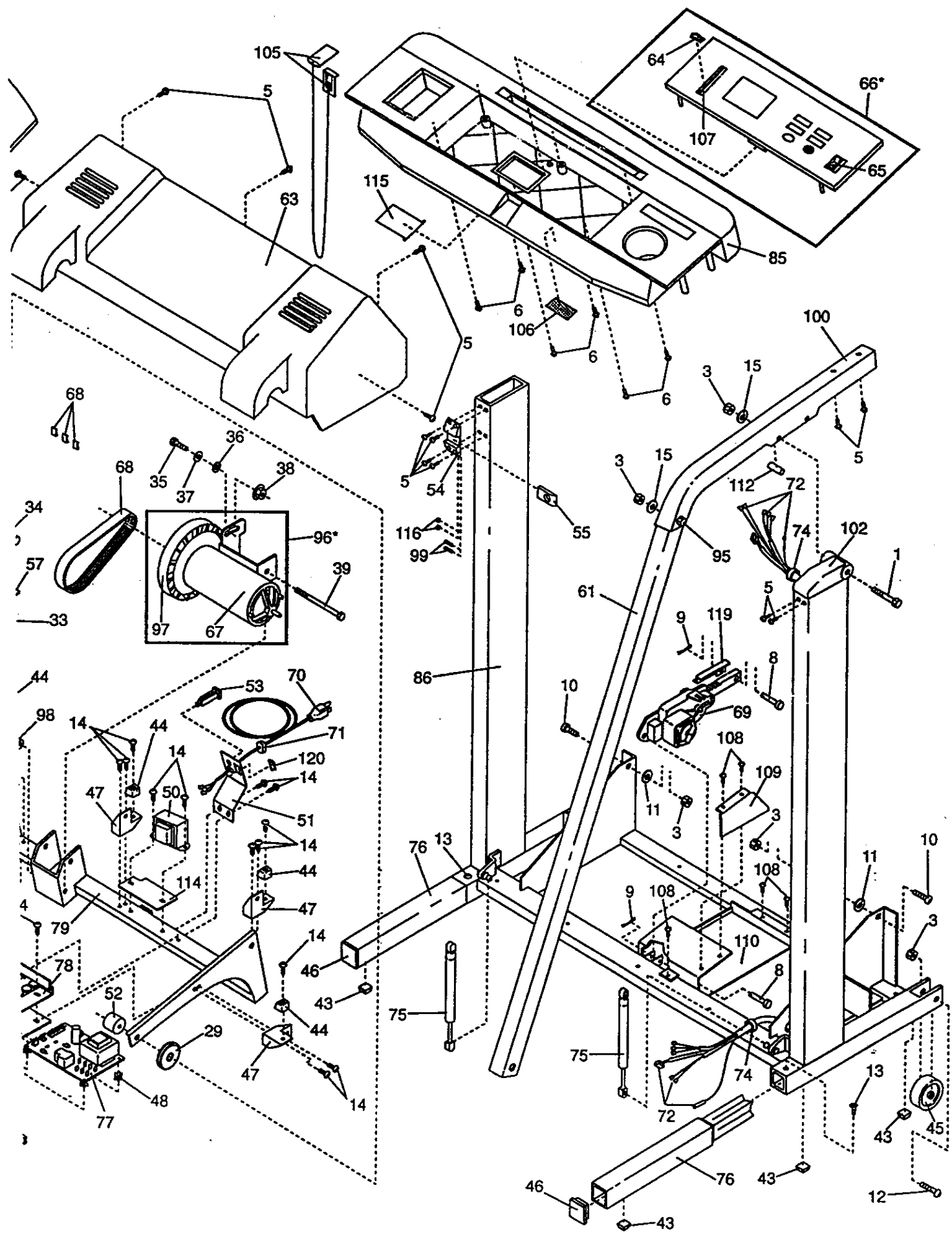

PART LIST—Model No. 831.297660

R1096B

Key No.	Part No.	Qty.	Description	Key No.	Part No.	Qty.	Description
1	104725	2	Upright Endcap Bolt	65	031108	1	Incline Switch
2	405988	1	Small Power Supply	66*	134324	1	Console
3	100427	12	Nut	67	134326	1	Motor
4	102073	2	Upright Bracket Bolt	68	126134	1	Motor Belt
5	013607	15	Small Screw	69	129875	1	Incline Motor
6	130459	6	Console Screw	70	124669	1	Power Cord
7	132549	1	Ground Wire	71	124695	1	Grommet
8	112669	2	Cotter Pin	72	134329	1	Wire Harness
9	106334	2	Hairpin Cotter Pin	73	132315	1	7 1/2" Wire Tie
10	132449	2	Hex-head bolt	74	129004	2	Wire Harness Grommet
11	101149	2	Washer	75	134331	2	Shock
12	117806	2	Base Wheel Bolt	76	132435	2	Base Extension
13	131826	2	Extension Bolt	77	134333	1	Power Supply w/Clips
14	013300	20	Screw	78	134333	1	Controller
15	014073	6	Washer	79	132173	1	Incline Leg
16	133072	5	Belly Pan Fastener	80	132453	1	Belly Pan
17	013456	4	Endcap Bolt	81	132473	1	Endcap Plug
18	105444	1	Adjustment Bolt (short)	82	132218	1	Rear Roller Cover
19	014127	4	Adjustment Washer	83	NSP	1	Frame
20	128272	6	Frame Isolator Screw	84	134335	1	Walking Platform
21	013576	4	Latch Frame Guide Screw	85	132074	1	Console Base
22	134300	2	Isolator	86	134341	1	Upright/Base
23	134302	8	Spring Cushion	87	132455	2	Endcap Foot
24	013540	6	Platform Screw	88	100498	1	Magnet
25	054023	3	Wire Clip	89	126040	1	Allen Wrench
26	128986	1	Tension Spring	90	016028	2	Adhesive Clip
27	123470	1	Spring Sleeve	91	118196	1	Reed Switch Extension
28	121576	3	Roller Tension Nut	92	134342	1	Walking Belt
29	132456	2	Spacer	93	134343	1	Frame Cover
30	134360	1	Roller Bushing (left)	94	128260	1	Adjustment Bolt (long)
31	127597	6	Endcap Fastener	95	132449	2	Handlebar Mount Bolt
32	133072	6	Pan Fastener	96*	134328	1	Motor/Pulley/Flywheel/Fan
33	120630	21	Small Screw	97	126747	1	Pulley/Flywheel/Fan
34	120354	2	Upright Pivot Bolt	98	012149	1	Motor Pivot Nut
35	013547	1	Motor Tension Bolt	99	129734	2	Latch Spring
36	014117	1	Star Washer	100	132424	1	Right Handlebar Arm
37	122812	1	Motor Tension Washer	101	131607	1	Book Rack
38	120867	1	Motor Tension Nut	102	132441	1	Right Upright Endcap
39	107503	1	Motor Pivot Bolt	103	016057	5	8" Wire Tie
40	132434	4	Spring	104	131605	1	Latch Warning Decal
41	132440	1	Upright Endcap (left)	105	119038	1	Key/Clip
42	132422	2	Upright Bracket	106	129232	2	Storage Warning Decal
43	129740	7	Base Pad	107	128113	1	Speed Potentiometer
44	125677	5	Hood Anchor	108	013162	5	Cover Screw
45	052012	2	Front Wheel	109	134338	1	Incline Cover Shield
46	103833	2	Base Extension Endcap	110	134337	1	Incline Cover
47	132394	5	Hood Bracket	111	132031	1	Frame Guide Spacer
48	125819	4	Plastic Stand-off	112	134346	2	Handrail Spacer
49	130251	2	Frame Guide	113	135003	2	Frame Spacer
50	130993	1	Choke	114	135004	1	Choke Plate
51	134347	1	Bracket	115	129639	1	Battery Cover
52	134361	1	Roller Bushing (right)	116	131562	1	Latch Pad
53	109382	1	Circuit Breaker	117	116926	1	Releaseable Tie
54	131753	1	Storage Latch Bracket	118	016029	2	4" Wire Tie
55	131738	1	Storage Latch	119	125738	1	Incline Bracket
56	132466	1	Electronics Bracket	120	126130	1	Bracket Plug
57	109265	2	Belt Guide	#	127860	12	Fastener
58	134303	1	Rear Roller	#	107771	1	8" White Wire, Male/Female
59	134305	1	Front Roller/Pulley	#	132371	1	6" White Wire, 2 Female
60	134307	2	Foot Rail	#	132370	1	6" Blue Wire, 2 Female
61	132426	2	Handlebar	#	132968	1	User's Manual
62	132565	1	Left Handlebar Arm				
63	134323	1	Hood				
64	131161	1	Speed Knob				

* Includes all parts shown in the box

These parts are not illustrated

SEARS

Model No. 831.297660

QUESTIONS?

If you find that:

- you need help assembling or operating the PROFORM® 585 TL treadmill
- a part is missing
- or you need to schedule repair service

call our toll-free HELPLINE

1-800-736-6879

Monday–Saturday, 7 am–7 pm
Central Time (excluding holidays)

REPLACEMENT PARTS

If parts become worn and need to be replaced, call the following toll-free number

1-800-FON-PART
(1-800-366-7278)

The model number and serial number of your PROFORM® 585 TL treadmill are listed on a decal attached to the frame. See the front cover of this manual to find the location of the decal.

All replacement parts are available for immediate purchase or special order when you visit your nearest SEARS Service Center. To request service or to order parts by telephone, call the toll-free numbers listed at the left.

When requesting help or service, or ordering parts, please be prepared to provide the following information:

- The NAME OF THE PRODUCT (PROFORM® 585 TL treadmill)
- The MODEL NUMBER OF THE PRODUCT (831.297660)
- The PART NUMBER OF THE PART (see the EXPLODED DRAWING and PART LIST included in this manual)
- The DESCRIPTION OF THE PART (see the EXPLODED DRAWING and PART LIST included in this manual).