

PRO-FORM[®] CROSS WALK 2.5

SEARS

Model No. 831.297380

Serial No. _____

The serial number is found in the location shown below. Write the serial number in the space above for reference.

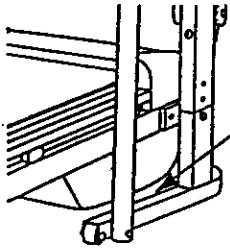

Serial
Number
Decal

EXERCISE
EQUIPMENT

QUESTIONS

HELPLINE!

1-800-736-6879

CAUTION

Read all precautions and instructions in this manual before using this equipment. Save this manual for future reference.

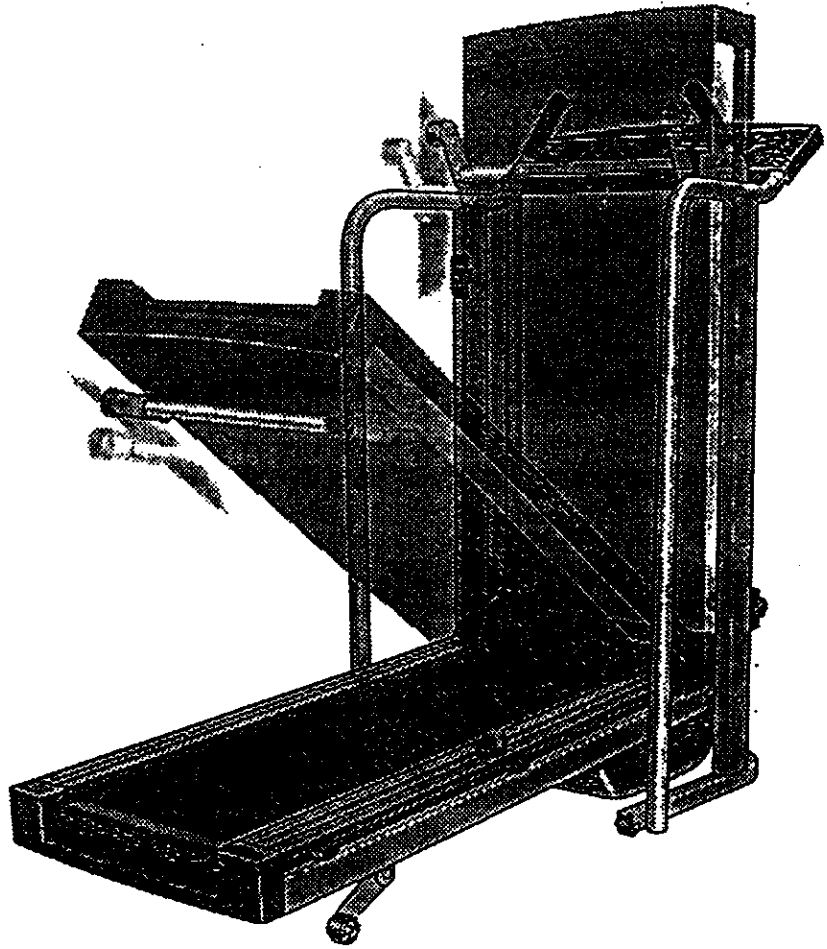

USER'S MANUAL

SEARS, ROEBUCK AND CO., HOFFMAN ESTATES, IL 60179

TABLE OF CONTENTS

IMPORTANT PRECAUTIONS	2
BEFORE YOU BEGIN	4
ASSEMBLY	5
OPERATION AND ADJUSTMENT	7
HOW TO FOLD AND MOVE THE TREADMILL	10
TROUBLE-SHOOTING	12
CONDITIONING GUIDELINES	14
ORDERING REPLACEMENT PARTS	Back Cover
FULL 90 DAY WARRANTY	Back Cover

Note: A HARDWARE IDENTIFICATION CHART, an EXPLODED DRAWING and a PART LIST are attached to the center of this manual. Please save them for future reference.

IMPORTANT PRECAUTIONS

⚠ WARNING: To reduce the risk of burns, fire, electric shock, or injury to persons, read the following important precautions and information before operating the treadmill.

1. It is the responsibility of the owner to ensure that all users of this treadmill are adequately informed of all warnings and precautions.
2. Use the treadmill only as described in this manual.
3. Place the treadmill on a level surface, with 8 feet of clearance behind it. Do not place the treadmill on any surface that blocks air openings. To protect the floor or carpet from damage, place a mat under the treadmill.
4. Keep the treadmill indoors, away from moisture and dust. Do not put the treadmill in a garage or covered patio, or near water.
5. Do not operate the treadmill where aerosol products are used or where oxygen is being administered.
6. Keep small children and pets away from the treadmill at all times.
7. The treadmill should be used only by persons weighing 250 pounds or less.
8. Never allow more than one person on the treadmill at a time.
9. Wear appropriate exercise clothing when using the treadmill. Do not wear loose clothing that could become caught in the treadmill. Athletic support clothes are recommended for both men and women. *Always wear athletic shoes. Never use the treadmill with bare feet, wearing only stockings, or in sandals.*
10. When connecting the power cord (see HOW TO PLUG IN THE POWER CORD on page 7), plug the power cord into a surge protector (not included) and plug the surge protector into a grounded circuit capable of carrying 15 or more amps. No other appliance should be on the same circuit.
11. Use only a UL-listed surge protector, rated at 15 amps, with a 14-gauge cord of five feet or less in length. Do not use an extension cord.
12. Keep the power cord and the surge protector away from heated surfaces.
13. Never move the walking belt while the power is turned off. Do not operate the treadmill if the power cord or plug is damaged, or if the treadmill is not working properly. (See BEFORE YOU BEGIN on page 4 if the treadmill is not working properly.)

14. Never start the treadmill while you are standing on the walking belt. Always hold the handrails or upper body arms while using the treadmill.

15. The treadmill is capable of high speeds. Adjust the speed in small increments to avoid sudden jumps in speed.

16. To reduce the possibility of the treadmill overheating, do not operate the treadmill continuously for longer than 1 hour.

17. The pulse sensor is not a medical device. Various factors, including the user's movement, may affect the accuracy of heart rate readings. The pulse sensor is intended only as an exercise aid in determining heart rate trends in general.

18. Never leave the treadmill unattended while it is running. Always remove the key when the treadmill is not in use.

19. Do not attempt to raise, lower, or move the treadmill until it is properly assembled. (See

ASSEMBLY on pages 5 and 6, and HOW TO MOVE THE TREADMILL on page 11.) You must be able to safely lift 45 pounds (20 kg) to raise, lower, or move the treadmill.

20. When folding or moving the treadmill, make sure that the storage latch is fully closed.

21. Inspect and tighten all parts of the treadmill every three months.

22. Never insert any object into any opening.

23. Always unplug the power cord before performing the maintenance and adjustment procedures described in this manual. Never remove the motor hood unless instructed to do so by an authorized service representative. Servicing other than the procedures in this manual should be performed by an authorized service representative only.

24. This treadmill is intended for in-home use only. Do not use this treadmill in any commercial, rental, or institutional setting.

⚠ WARNING: Before beginning this or any exercise program, consult your physician. This is especially important for persons over the age of 35 or persons with pre-existing health problems. Read all instructions before using. SEARS assumes no responsibility for personal injury or property damage sustained by or through the use of this product.

SAVE THESE INSTRUCTIONS

The decal shown at the right has been placed on your treadmill. If the decal is missing, or if it is not legible, please call our toll-free HELPLINE to order a free replacement decal (see the back cover of this manual). Apply the decal in the location shown.

⚠ WARNING!

- Never allow children to play on or around treadmill.
- Storage latch must be fully engaged before treadmill is moved or stored.

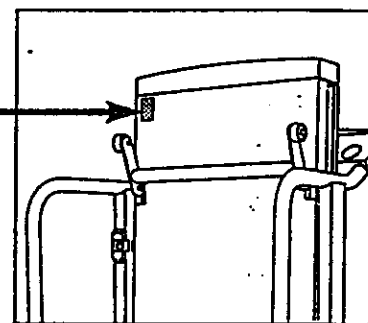
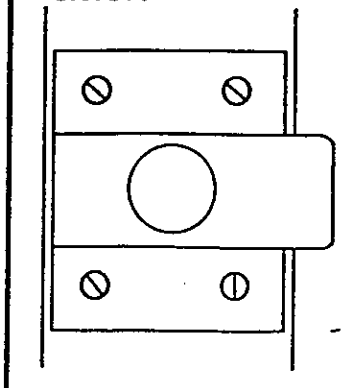

BEFORE YOU BEGIN

Thank you for selecting the PROFORM® CROSS-WALK 2.5 treadmill. The CROSSWALK 2.5 treadmill blends advanced technology with innovative design to let you enjoy an excellent form of cardiovascular exercise in the convenience and privacy of your home.



For your benefit, read this manual carefully before using the treadmill. If you have additional questions, please call our toll-free HELPLINE at 1-800-736-6879, Monday through Saturday, 7 a.m. until 7 p.m. Central

Time (excluding holidays). To help us assist you, please note the product model number and serial number before calling. The model number of the treadmill is 831.297380. The serial number can be found on a decal attached to the treadmill (see the front cover of this manual for the location).

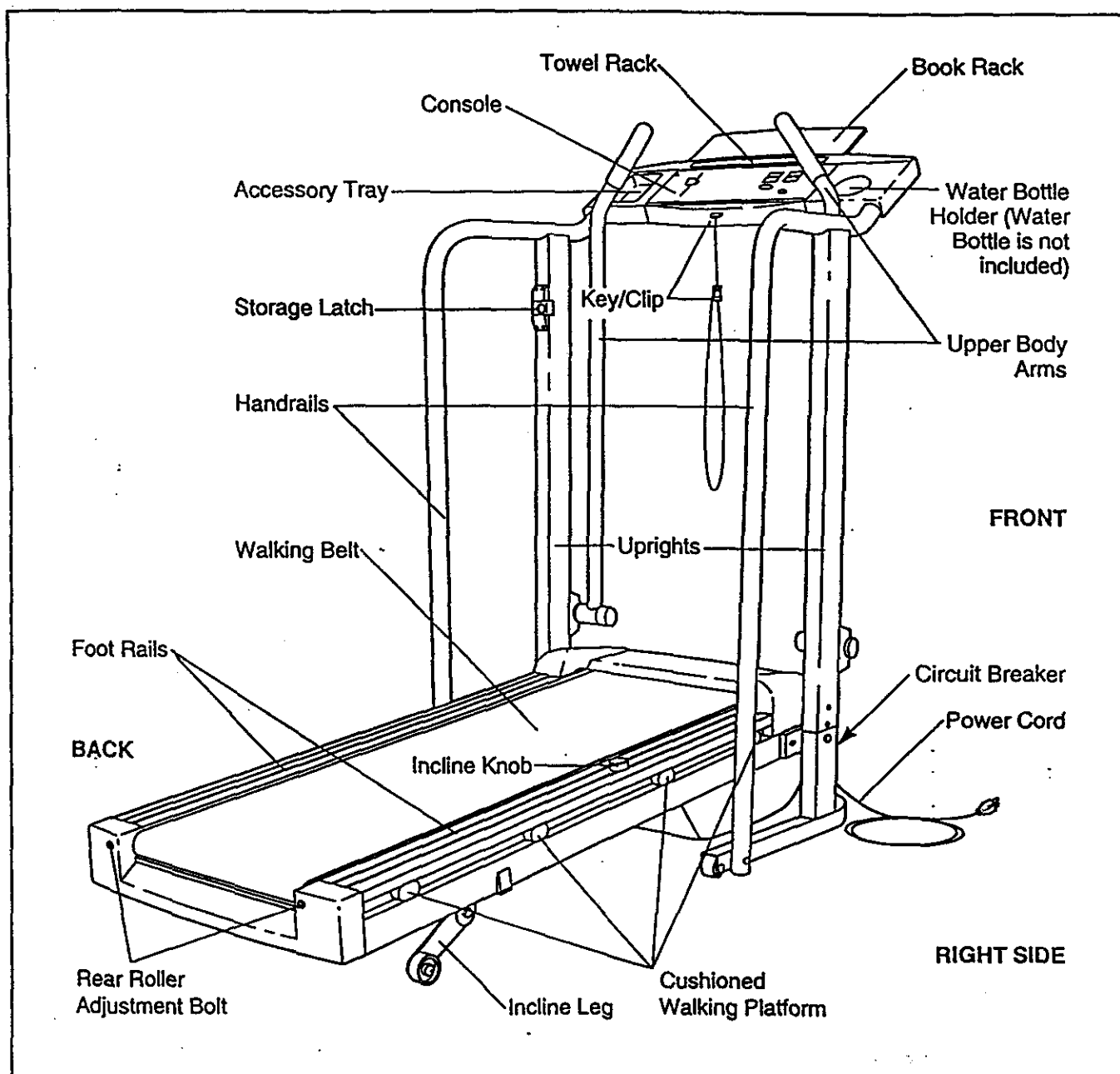
Before reading further, please review the drawing below and familiarize yourself with the parts that are labeled.

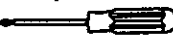
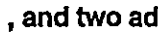

ASSEMBLY

CAUTION: Read and follow step 1 below before removing the restraining tie (see drawing 1). If the restraining tie is removed prematurely, serious bodily injury may result. Assembly requires two people. Set the treadmill in a cleared area and remove the packing materials except for the restraining tie. Do not dispose of the packing materials until assembly is completed. Use the **HARDWARE IDENTIFICATION CHART** in the center of this manual to identify the parts used in assembly. Assembly requires the included allen wrench , a phillips screwdriver , and two adjustable wrenches .

1. Slide the Left Upright (1) onto the left side of the Base (59). It may be necessary to firmly push down on the Left Upright until it is fully seated on the Base. Remove the restraining tie from the Base.

Attach the left handrail to the Base (59) with a Handrail Bolt (93), 3/8" Washer (67), and Handrail Nut (4). Do not tighten the Handrail Bolt yet. Using the allen wrench, tighten two Upright Screws (63) into the Left Upright (1) and Base.

2. Slide the Right Upright (44) onto the right side of the Base (59). It may be necessary to firmly push down on the Right Upright until it is fully seated on the Base. Be careful not to pinch the Wire Harness (25) between the Right Upright and the Base.

Attach the right handrail to the Base (59) with a Handrail Bolt (93), 3/8" Washer (67), and Handrail Nut (4). Do not tighten the Handrail Bolt yet. Using the allen wrench, tighten two Upright Screws (63) into the Right Upright (44) and Base.

Hand tighten the Handrail Nuts (4) used in steps 1 and 2. Using a wrench, tighten the Handrail Bolts (93) used in steps 1 and 2.

Remove the wire ties (not shown) attaching the Console Base (9) to the Right Upright (44).

3. Set the Console Base (9) on the Left and Right Uprights (1, 44).

While one person carefully feeds any slack Wire Harness (25) down into the Right Upright (44), a second person should carefully pull the slack Wire Harness from the lower end of the Right Upright.

Attach the Console Base (9) with four Screws (75).

Align the holes in the Book Rack (62) with those in the Console Base (9). Attach the Book Rack to the Console Base with four Screws (75) as shown.

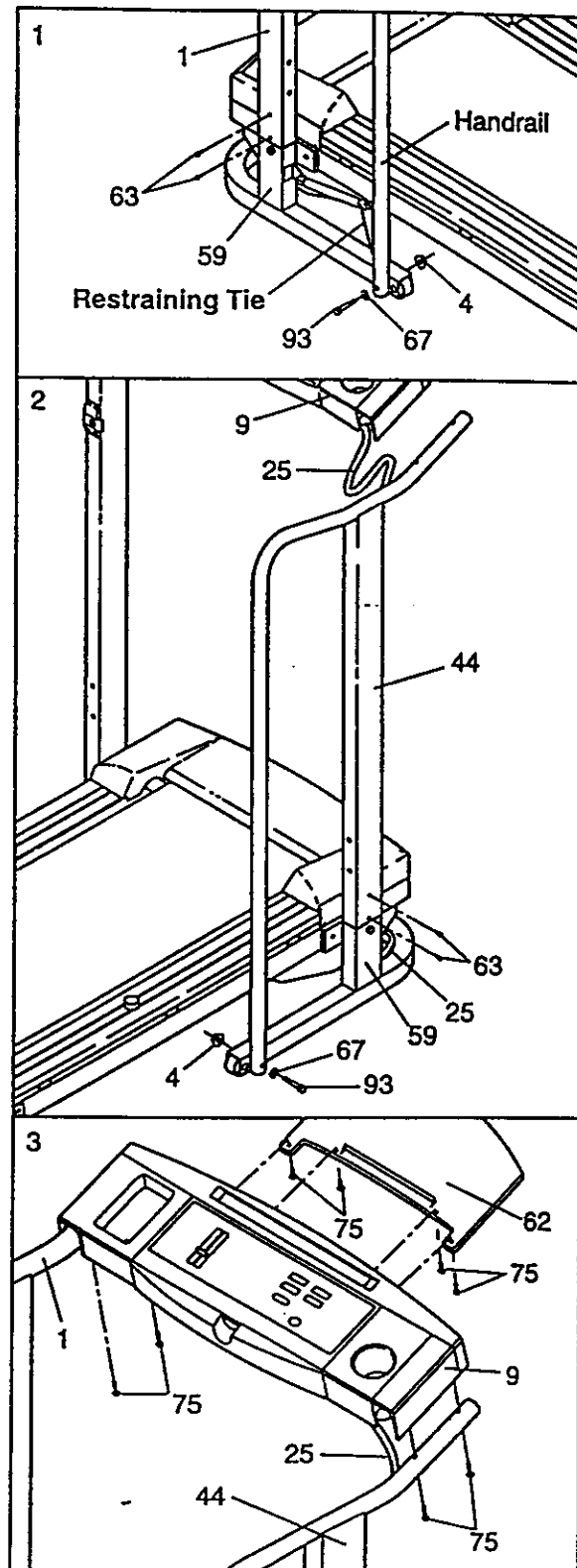

4. With the help of a second person, carefully lower the Left and Right Uprights (1, 44) until the handrails are resting on the floor.

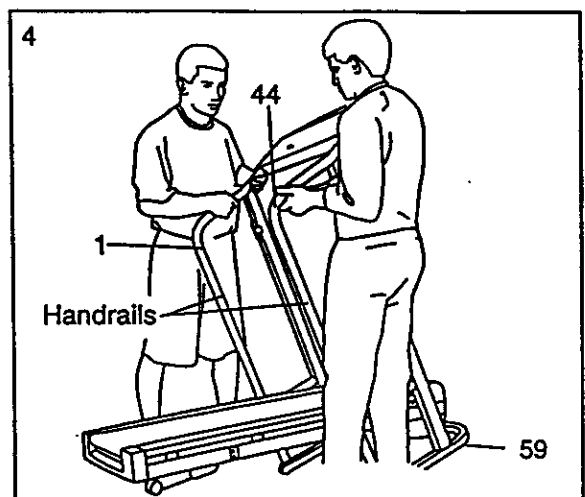

5. Attach six Base Pads (57) to the bottom of the Base (59) in the indicated locations. Note: An extra Base Pad may be included.

See drawing 4 above. With the help of a second person, raise the Left and Right Uprights (1, 44) until the Base (59) is resting flat on the floor.

Before moving the treadmill, see **HOW TO MOVE THE TREADMILL** on page 11.

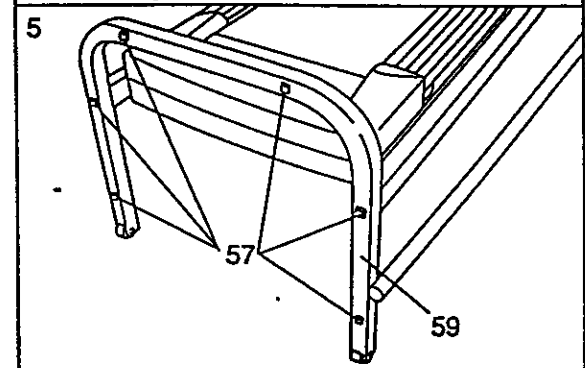

6. Insert two Resistance Bracket Bolts (107) with Bracket Washers (70) into the Left Upright (1). Slide two Star Washers (103), a Spacer (106), and two more Star Washers (103) onto the Bolts. Make sure that the Spacer is turned so the widest side is facing the Left Upright. Tighten the Bolts into the Resistance Bracket (104) at the lower end of the left Upper Body Arm (96). (Note: It may be necessary to loosen the Resistance Knob [97] and pivot the Resistance Bracket.)

Attach the right Upper Body Arm (96) as described above. Make sure that both Upper Body Arms are on the correct side of the Console Base (9) as shown.

See drawing 2 on page 5. Feed the slack Wire Harness (25) into the Base (59).

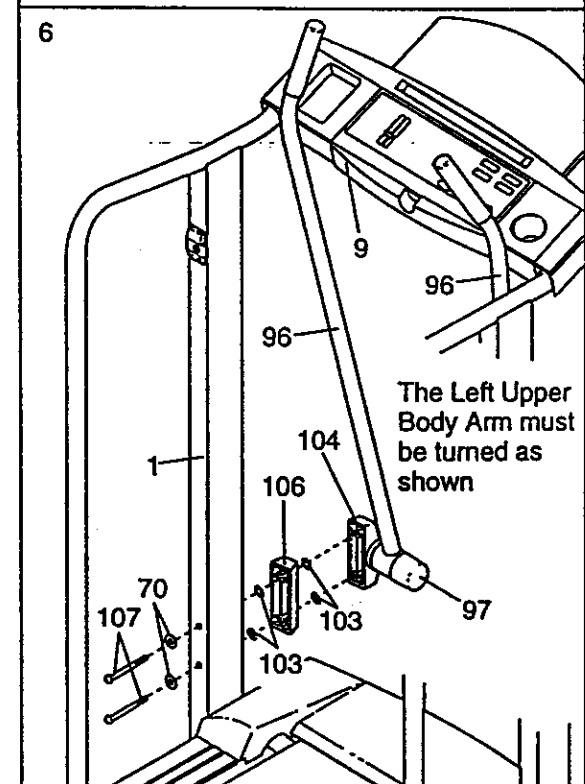

7. Remove the backing from the Adhesive Clip (77). Press the Adhesive Clip onto the Rear Roller Endcap (78) in the indicated location. Press the Allen Wrench (76) into the Adhesive Clip.

Make sure that all parts are tightened before you use the treadmill. Note: To protect the floor or carpet, place a mat under the treadmill. For information on ordering a mat, see **REPLACEMENT PARTS** on the back cover.

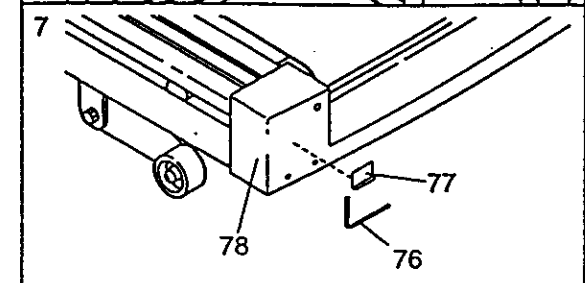

OPERATION AND ADJUSTMENT

THE PERFORMANT LUBE™ WALKING BELT

Your treadmill features a walking belt coated with PERFORMANT LUBE™, a high-performance lubricant. **IMPORTANT:** Never apply silicone spray or other substances to the walking belt or the walking platform. They will deteriorate the walking belt and cause excessive wear.

HOW TO PLUG IN THE POWER CORD

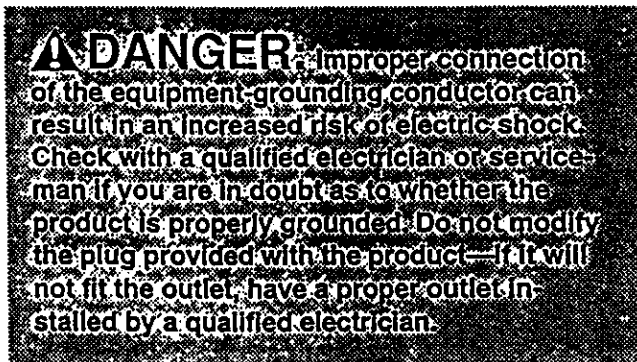

Your treadmill, like any other type of sophisticated electronic equipment, can be seriously damaged by sudden voltage changes in your home's power. Voltage surges, spikes, and noise interference can result from weather conditions or from other appliances being turned on or off. To decrease the possibility of your treadmill being damaged, always use a surge protector (not included) with your treadmill.

Surge protectors are sold at most hardware stores and department stores. Use only a UL-listed surge protector, rated at 15 amps, with a 14-gauge cord of five feet or less in length.

This product must be grounded. If it should malfunction or break down, grounding provides a path of least resistance for electric current to reduce the risk of

electric shock. This product is equipped with a cord having an equipment-grounding conductor and a grounding plug. Plug the power cord into a surge protector, and plug the surge protector into an appropriate outlet that is properly installed and grounded in accordance with all local codes and ordinances.

This product is for use on a nominal 120-volt circuit, and has a grounding plug that looks like the plug illustrated in drawing 1 below. A temporary adapter that looks like the adapter illustrated in drawing 2 may be used to connect the surge protector to a 2-pole receptacle as shown in drawing 2 if a properly grounded outlet is not available.

The temporary adapter should be used only until a properly grounded outlet (drawing 1) can be installed by a qualified electrician.

The green-colored rigid ear, lug, or the like extending from the adapter must be connected to a permanent ground such as a properly grounded outlet box cover. Whenever the adapter is used it must be held in place by a metal screw. Some 2-pole receptacle outlet box covers are not grounded. Contact a qualified electrician to determine if the outlet box cover is grounded before using an adapter.

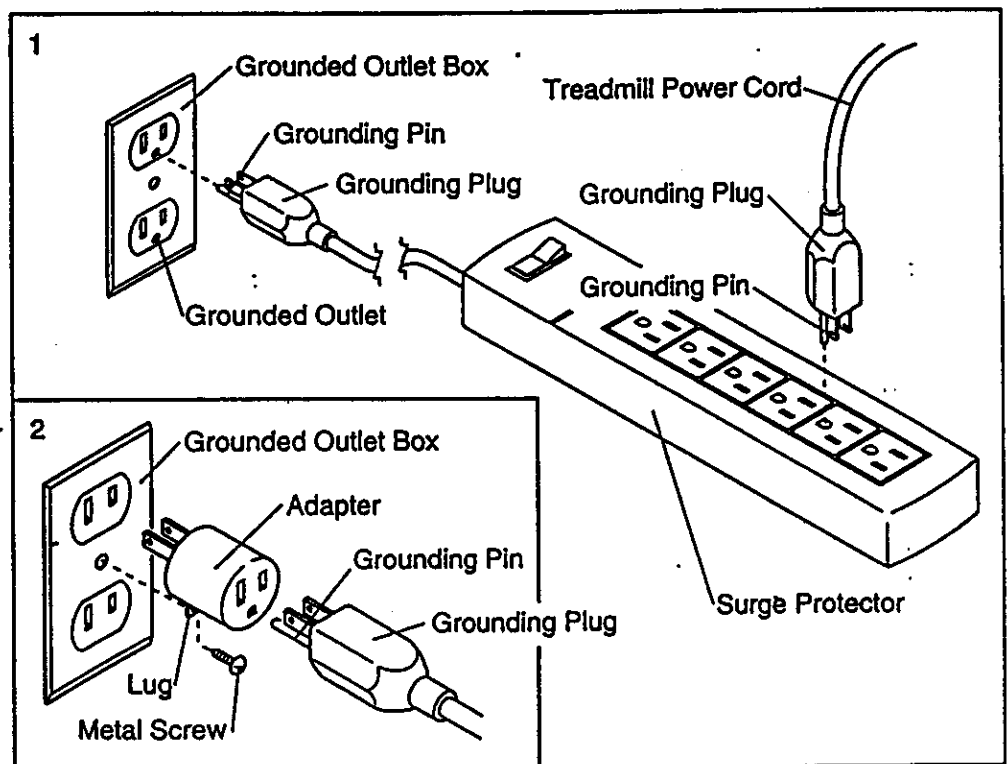
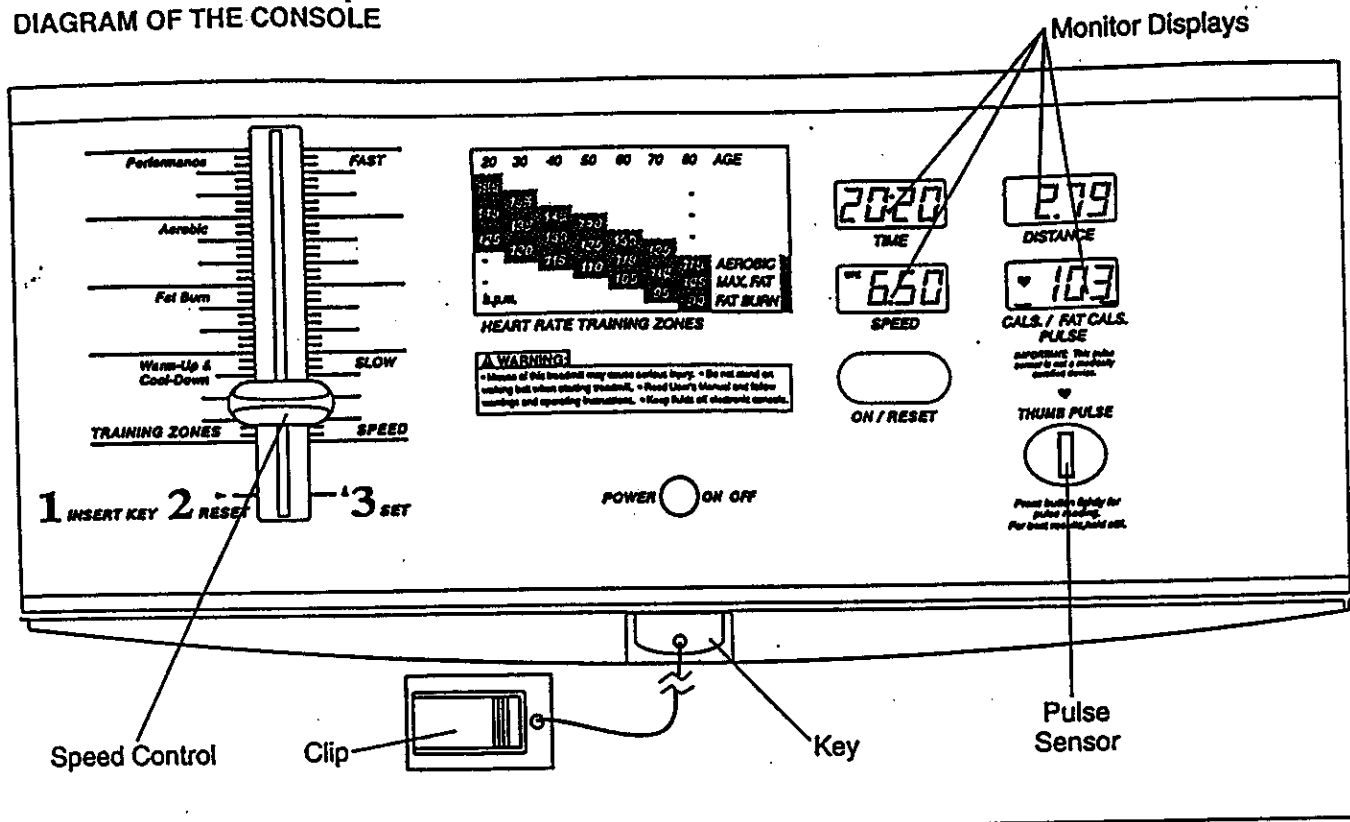

DIAGRAM OF THE CONSOLE



CAUTION: Before operating the console, read the following precautions:

- Do not stand on the walking belt when turning on the power.
- Always wear the clip (see the drawing above) while using the treadmill. When the key is removed from the console, the walking belt will stop.
- Adjust the speed in small increments.
- The training zones marked beside the speed control are general guidelines only. See pages 14 and 15 for more information.
- To reduce the possibility of electric shock, keep the console dry. Avoid spilling liquids on the console. Use only a sealed water bottle.

BATTERY INSTALLATION

The console requires three "AA" batteries (not included). Alkaline batteries are recommended. To install batteries, open the battery cover under the console as shown below. Press three batteries into the battery compartment.

Make sure that the negative (-) ends of the batteries are touching the springs. Close the battery cover.

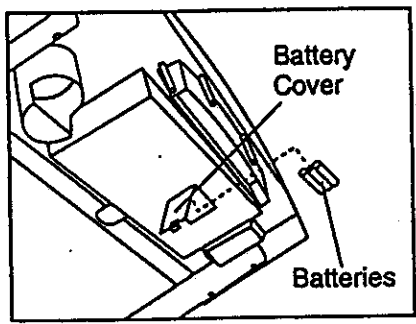

STEP BY STEP CONSOLE OPERATION

Before operating the console, make sure that the power cord is properly plugged in. (See HOW TO PLUG IN THE POWER CORD on page 7.) If there is a thin sheet of clear plastic on the face of the console, remove it.

Next, step onto the foot rails of the treadmill. Find the clip attached to the key (see the drawing above), and slide the clip onto the waistband of your clothing.

Follow the steps on page 9 to operate the console.

1 Insert the key fully into the power switch.

Inserting the key will not turn on the displays. The displays will turn on when the ON/RESET button is pressed or when the walking belt is started.

Note: If you just installed batteries, the displays will already be on.

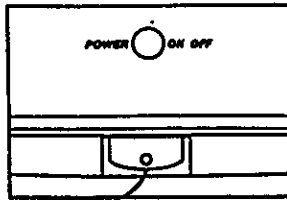

2 Reset the speed control.

Slide the speed control down to the RESET position. Note: Each time the walking belt is stopped, the speed control must be moved to the RESET position before the walking belt can be restarted.

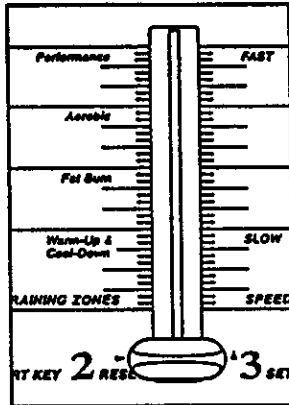

3 Start the walking belt.

After you have moved the speed control to the RESET position, slowly slide it upward until the walking belt begins to move at slow speed. Carefully step onto the walking belt and begin exercising. Change the speed of the walking belt as desired by sliding the speed control.

To stop the walking belt, step onto the foot rails and slide the speed control to the RESET position.

4 Follow your progress with the monitor displays.

TIME display—This display shows the total time that you have walked or run on the treadmill.



DISTANCE display—This display shows the total distance that you have walked or run, in miles.

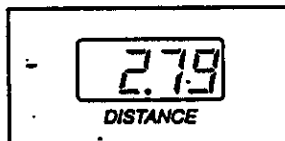

SPEED display—This display shows the speed of the walking belt, in miles per hour.



CALORIES/FAT CALORIES/PULSE display—This display shows the approximate numbers of calories and fat calories you have burned. (See FAT CALORIES on page 14 for an explanation of fat calories.) Every seven seconds, the display will change from one number to the other. Arrows in the display will indicate which number is currently shown. Note: This display will also show your pulse when the pulse sensor is used.

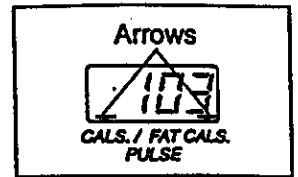

The displays can be reset, if desired, by pressing the ON/RESET button.



5 Measure your pulse, if desired.

To use the pulse sensor, stand on the foot rails and place your thumb on the pulse sensor as shown. The pulse sensor is pressure-activated; fully press down

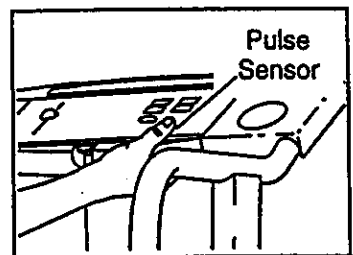

the pulse sensor. Do not press too hard, or the circulation in your thumb will be restricted, and your pulse will not be detected. Next, slightly raise your thumb until the heart-shaped indicator in the CALORIES/FAT CALORIES/PULSE display flashes steadily.

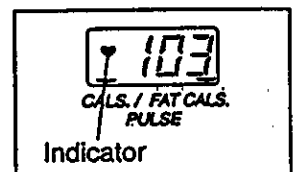

Hold your thumb at this level. After 5 to 10 seconds, your pulse will be shown. Hold your thumb on the sensor for another 15 seconds for the most accurate reading. If the displayed pulse appears to be too high or too low, or if your pulse is not displayed, lift your thumb off the sensor and allow the display to reset. Press down again on the sensor as described above.

Make sure that your thumb is positioned as shown, and that you are applying the proper amount of pressure to the pulse sensor. Try the sensor several times until you become familiar with it. Remember to stand still while measuring your pulse.

6 When you are finished exercising, stop the walking belt and remove the key.

Step onto the foot rails, stop the walking belt, and remove the key from the console. Store the key in a secure place. After the key is removed, the displays will remain on for about five minutes.

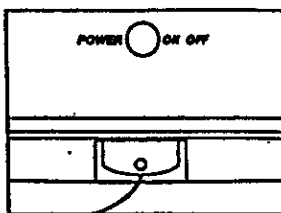

Note: Any time that the walking belt is stopped and no console buttons are pressed for five minutes, the displays will automatically turn off in order to conserve the batteries.

HOW TO USE THE UPPER BODY ARMS

As you exercise on the treadmill, you can hold either the handrails or the upper body arms. The upper body arms are designed to exercise your arms, shoulders, and back for a total body workout. Hold one upper body arm with each hand, and move them forward and back as you walk on the treadmill.

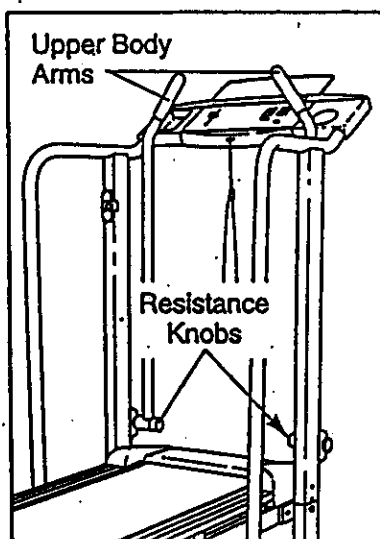

To vary the intensity of your upper body exercise, the resistance of the upper body arms can be adjusted. To increase the resistance, turn the resistance knobs clockwise; to decrease the resistance, turn the knobs counterclockwise.

HOW TO CHANGE THE INCLINE OF THE TREADMILL

The incline of the treadmill can be changed by raising or lowering the back end. Before changing the incline, remove the key and unplug the power cord.

Hold the rear roller endcap with both hands. When the back end of the treadmill is in the lowest position, the incline is about 10%.

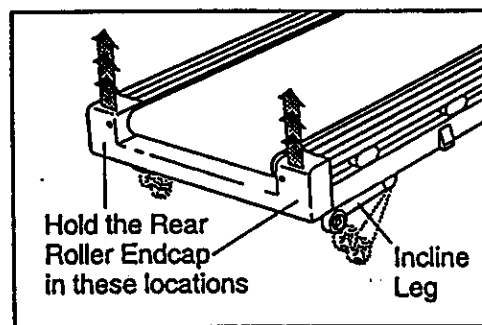

Raise the back end until it clicks into position. (Note: it may be necessary to shake the treadmill slightly so that it clicks into position.) The incline will then be about 5%. Raise the back end again until it clicks into position. The incline will then be about 3%. To lower the back end, first raise it past the highest position, and then lower it. **CAUTION:** Before exercising, push on the back of the treadmill to make sure that the incline legs are locked in position. Do not place objects under the treadmill to change the incline; change the incline only as described above.

HOW TO FOLD AND MOVE THE TREADMILL

HOW TO FOLD THE TREADMILL FOR STORAGE

Before folding the treadmill, unplug the power cord. **Caution:** You must be able to safely lift 45 pounds (20 kg) in order to raise, lower, or move the treadmill.

1. Hold the treadmill with your hands in the locations shown at the right. To decrease the possibility of injury, bend your legs and keep your back straight. As you raise the treadmill, make sure to lift with your legs rather than your back. Raise the treadmill about halfway to the vertical position.

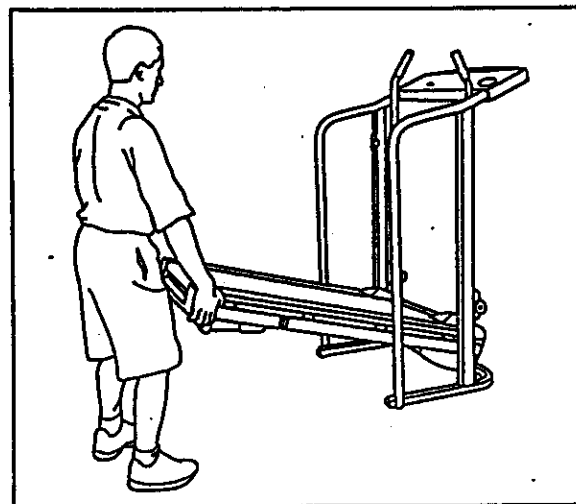

2. Move your right hand to the position shown and hold the treadmill firmly. Raise the treadmill until the storage latch closes over the frame guide. Make sure that the storage latch closes fully over the frame guide.

To protect the floor or carpet from damage, place a mat under the treadmill. Keep the treadmill out of direct sunlight. Do not leave the treadmill in the storage position in temperatures above 85° Fahrenheit.

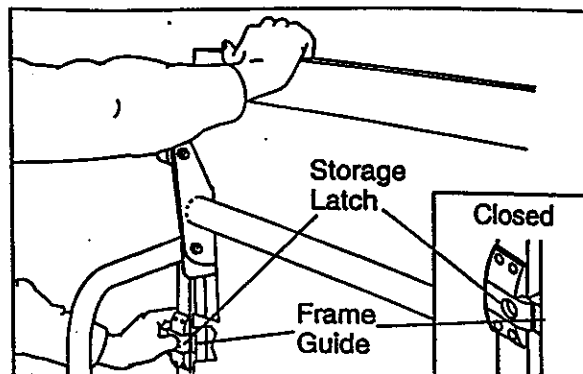

HOW TO MOVE THE TREADMILL

Before moving the treadmill, convert the treadmill to the storage position as described above. Make sure that the storage latch is closed fully over the frame guide.

1. Hold the upper ends of the handrails. Place one foot on the base as shown.
2. Tilt the treadmill back until it rolls freely on the front wheels. Carefully move the treadmill to the desired location. Never move the treadmill without tipping it back, or the base pads may come off. To reduce the risk of injury, use extreme caution while moving the treadmill. Do not attempt to move the treadmill over an uneven surface.
3. Place one foot on the base, and carefully lower the treadmill until it is resting in the storage position.

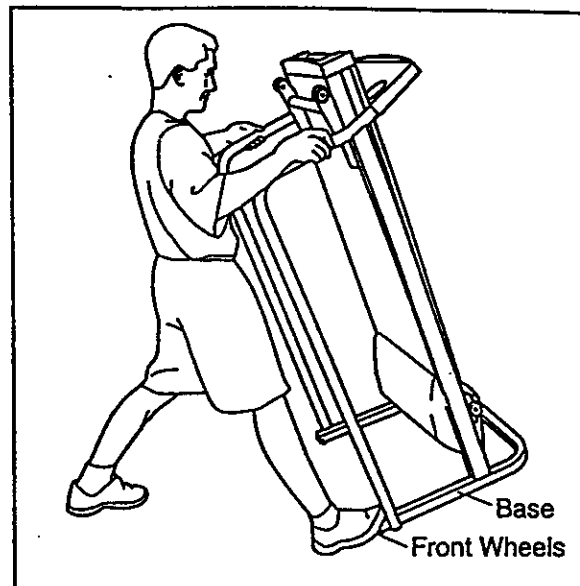

HOW TO LOWER THE TREADMILL FOR USE

1. Hold the upper end of the treadmill with your right hand as shown. Using your left thumb, slide open the storage latch and hold it open. Pivot the treadmill until the frame and foot rail are past the storage latch.
2. Hold the treadmill firmly with both hands, and lower the treadmill to the floor. To decrease the possibility of injury, bend your legs and keep your back straight.

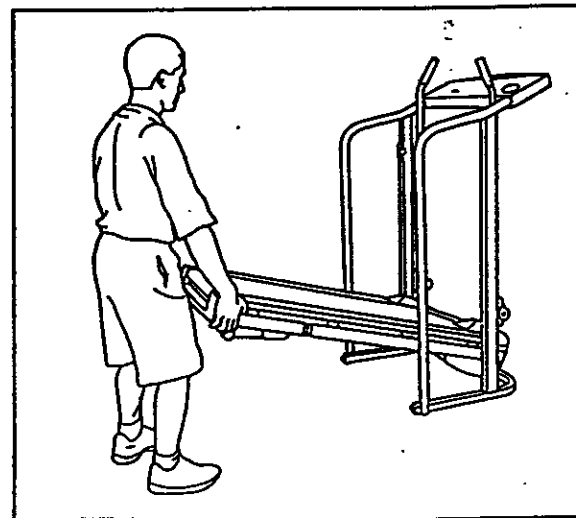
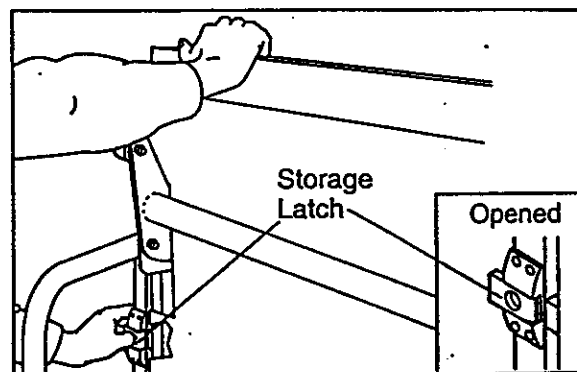

TROUBLE-SHOOTING

Most treadmill problems can be solved by following the simple steps below. Find the symptom that applies, and follow the steps listed. If further assistance is needed, call our toll-free HELPLINE at 1-800-736-6879, Monday through Saturday, 7 a.m. until 7 p.m. Central Time (excluding holidays).

1. SYMPTOM: THE POWER DOES NOT TURN ON

- a. Make sure that the power cord is plugged into a surge protector, and that the surge protector is plugged into a properly grounded outlet. (See HOW TO PLUG IN THE POWER CORD on page 7.) Use only a UL-listed surge protector, rated at 15 amps, with a 14-gauge cord of five feet or less in length.
- b. After the power cord has been plugged in, make sure that the key is fully inserted into the console. (See step 1 on page 9.)
- c. Check the circuit breaker located on the treadmill near the power cord. If the switch protrudes as shown, the circuit breaker has tripped. To reset the circuit breaker, wait for five minutes and then press the switch back in.

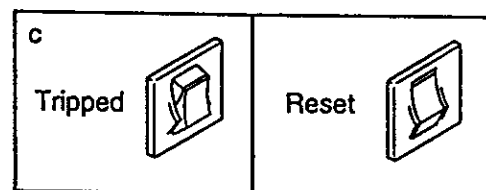

2. SYMPTOM: THE POWER TURNS OFF DURING USE

- a. Check the circuit breaker located on the treadmill frame near the power cord (see 1. c. above). If the circuit breaker has tripped, wait for five minutes and then press the switch back in.
- b. Make sure that the power cord is plugged in.
- c. Remove the key from the console. Reinsert the key fully into the console. (See step 1 on page 9.)
- d. If the treadmill still will not run, please call our toll-free HELPLINE.

3. SYMPTOM: THE INCLINE SYSTEM STICKS

- a. Raise the treadmill to the storage position. (See HOW TO FOLD THE TREADMILL FOR STORAGE on page 10.) Pivot the incline leg several times to break in the incline system.

4. SYMPTOM: THE WALKING BELT SLOWS WHEN WALKED ON

- a. Use only a UL-listed surge protector, rated at 15 amps, with a 14-gauge cord of five feet or less in length.
- b. If the walking belt is overtightened, treadmill performance may decrease and the walking belt may be permanently damaged. Remove the key and UNPLUG THE POWER CORD. Using the allen wrench, turn both rear roller adjustment bolts counterclockwise, 1/4 of a turn. When the walking belt is properly tightened, you should be able to lift each side of the walking belt 2-3 inches off the walking platform. The center of the walking belt should just touch the walking platform. Be careful to keep the walking belt centered. Plug in the power cord, insert the key and run the treadmill for a few minutes. Repeat until the walking belt is properly tightened.

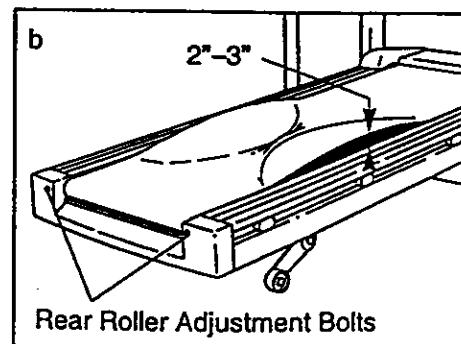

- c. If the walking belt still slows when walked on, please call our toll-free HELPLINE.

5. SYMPTOM: THE TREADMILL SITS UNEVENLY ON THE FLOOR

- a. Make sure that the six base pads are attached to the treadmill (see assembly step 5 on page 6).

6. SYMPTOM: THE WALKING BELT IS OFF-CENTER WHEN WALKED ON

- a. If the walking belt has shifted to the left, first remove the key and **UNPLUG THE POWER CORD**. Using the 3/16" end of the allen wrench, turn the left rear roller adjustment bolt clockwise, and the right bolt counterclockwise, 1/4 of a turn each. Be careful not to overtighten the walking belt. Plug in the power cord, insert the key and run the treadmill for a few minutes. Repeat until the walking belt is centered.
- b. If the walking belt has shifted to the right, first remove the key and **UNPLUG THE POWER CORD**. Using the 3/16" end of the allen wrench, turn the left rear roller adjustment bolt counterclockwise, and the right bolt clockwise, 1/4 of a turn each. Be careful not to overtighten the walking belt. Plug in the power cord, insert the key and run the treadmill for a few minutes. Repeat until the walking belt is centered.
- c. If the walking belt slips when walked on, first remove the key and **UNPLUG THE POWER CORD**. Using the 3/16" end of the allen wrench, turn both rear roller adjustment bolts clockwise, 1/4 of a turn. When the walking belt is correctly tightened, you should be able to lift each side of the walking belt 2-3 inches off the walking platform. The center of the walking belt should just touch the walking platform. Be careful to keep the walking belt centered. Plug in the power cord, insert the key and run the treadmill for a few minutes. Repeat until the walking belt is properly tightened.

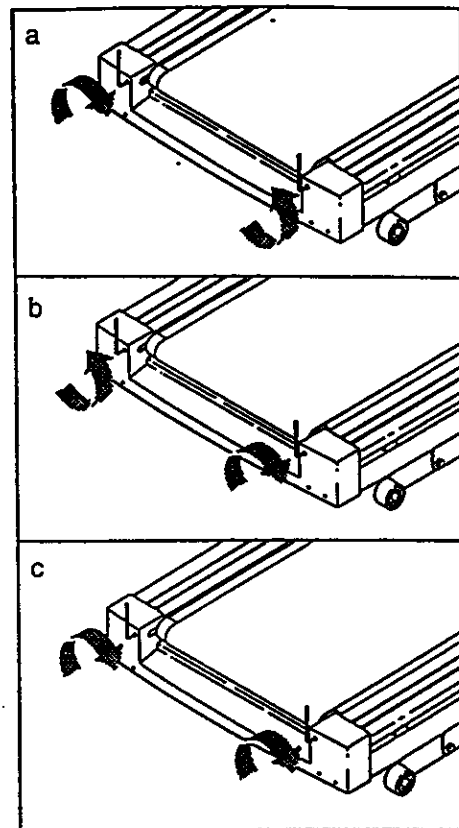

7. SYMPTOM: ONE OF THE UPPER BODY ARMS SQUEAKS DURING USE

- a. Correcting this problem requires a small amount of white marine grease, available at most hardware stores.

Turn the Resistance Knob (97) counterclockwise until it can be removed. Remove the Resistance Cone (98) and the Upper Body Arm (96), along with the 3/8" Washers (67), Spring Washer (5), Thrust Washers (101), and Thrust Bearing (102). (Note: If the Resistance Sleeve [99] comes out of the Resistance Bracket [104], press it back in.) Apply a thin layer of white marine grease to the outer surface of the Resistance Cone (98). Reattach all parts in the order shown at the right.

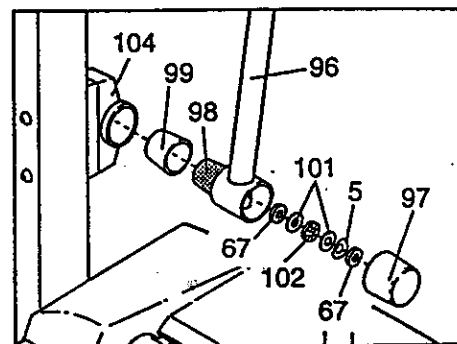

8. SYMPTOM: THE DISPLAYS OF THE CONSOLE DO NOT FUNCTION PROPERLY

- a. Check the batteries in the console. (See **BATTERY INSTALLATION** on page 8.) Most problems are the result of drained batteries.
- b. If the speed display does not show a correct reading, remove the key and **UNPLUG THE POWER CORD**. Raise the treadmill to the storage position. (See **HOW TO FOLD THE TREADMILL FOR STORAGE** on page 10.) Remove the four indicated screws. Next, lower the treadmill. (See **HOW TO LOWER THE TREADMILL FOR USE** on page 11). Remove the four screws from the sides of the hood. Carefully slide the hood forward and remove it. See page 14 for further instructions.

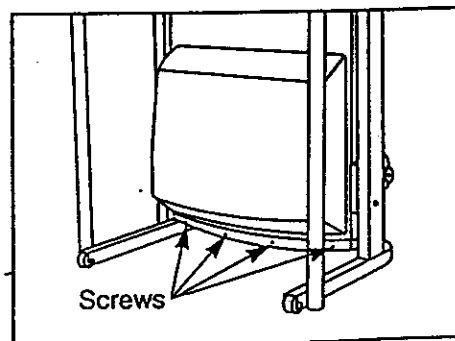

Locate the Reed Switch (38) and the Magnet (39) on the left side of the Pulley (90). Turn the Pulley until the Magnet is aligned with the Reed Switch. Make sure that the gap between the Magnet and the Reed Switch is about 1/8". If necessary, loosen the Screw (19) and move the Reed Switch slightly. Retighten the Screw. Re-attach the hood (see 8. b. on page 13), and run the treadmill for a few minutes to check for a correct speed reading.

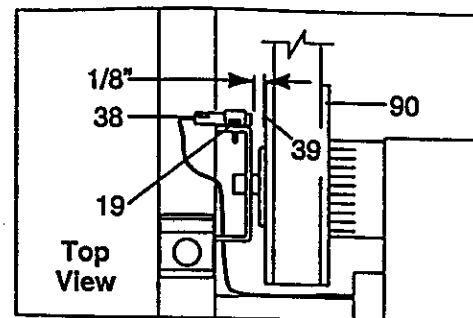

CONDITIONING GUIDELINES

⚠ WARNING: Before beginning this or any exercise program, consult your physician. This is especially important for individuals over the age of 35 or individuals with pre-existing health problems.

The pulse sensor is not a medical device. Various factors, including your movement, may affect the accuracy of heart rate readings. The sensor is intended only as an exercise aid in determining heart rate trends in general.

The following guidelines will help you to plan your exercise program. Remember—these are general guidelines only. For more detailed exercise information, obtain a reputable book or consult your physician.

EXERCISE INTENSITY

Whether your goal is to burn fat or to strengthen your cardiovascular system, the key to achieving the desired results is to exercise with the proper intensity. The proper intensity level can be found by using your heart rate as a guide. The chart below shows recommended heart rates for fat burning and aerobic exercise. (This chart is also found on the console.)

20	30	40	50	60	70	80	AGE
165							
145	155						
125	138	145	140				
	120	130	125	130	125		
		115	110	118	115	115	AEROBIC
			105	110	105	105	MAX. FAT
				95	90	90	FAT BURN

b.p.m.

HEART RATE TRAINING ZONES

To find the proper heart rate for you, first find your age at the top of the chart (ages are rounded off to the nearest ten years). Next, find the three numbers below your age. The three numbers are your "training zone." The lower two numbers are recommended heart rates for fat burning; the higher number is the recommended heart rate for aerobic exercise.

Fat Burning

To burn fat effectively, you must exercise at a relatively low intensity level for a sustained period of time. During the first few minutes of exercise, your body uses easily accessible *carbohydrate calories* for energy. Only after the first few minutes does your body begin to use stored *fat calories* for energy. If your goal is to burn fat, adjust the speed and incline of the treadmill until your heart rate is near one of the lower two numbers in your training zone. It may also be helpful to set the speed control on the console to FAT BURN to help you maintain the proper intensity level. (See page 9.)

Aerobic Exercise

If your goal is to strengthen your cardiovascular system, your exercise must be "aerobic." Aerobic exercise is activity that requires large amounts of oxygen for prolonged periods of time. This increases the demand on the heart to pump blood to the muscles, and on the lungs to oxygenate the blood. For aerobic exercise, adjust the speed and incline of the treadmill until your heart rate is near the higher number in your training zone. It may also be helpful to set the speed control on the console to AEROBIC to help you maintain the proper intensity level. (See page 9.)

High Performance Athletic Conditioning

If your goal is high performance athletic conditioning, set the speed control on the console to **PERFORMANCE** to help you maintain the proper intensity level. (See page 9.) Note: During the first few weeks of your exercise program, keep your heart rate near the low end of your training zone.

HOW TO MEASURE YOUR HEART RATE

To measure your heart rate, use the pulse sensor on the console. (See page 9.) If your heart rate is too high or too low, adjust the speed or incline of the treadmill until your heart rate is at the proper level.

WORKOUT GUIDELINES

Each workout should include three important parts:

A Warm-up

Begin with 5 to 10 minutes of stretching and light exercise. Warming up increases the body temperature, heart rate, and circulation in preparation for vigorous exercise.

Training Zone Exercise

After warming up, increase the intensity of your exercise until your heart rate is in your training zone for 20 to 60 minutes. (During the first few weeks of your exercise program, do not keep your heart rate in your training zone for longer than 20 minutes.) Breathe regularly and deeply as you exercise—never hold your breath.

A Cool-down

Finish each workout with 5 to 10 minutes of stretching to cool down. This will increase the flexibility of your muscles and will help to prevent post-exercise problems.

Exercise Frequency

To maintain or improve your condition, complete three workouts each week, with at least one day of rest between workouts. After a few months, you may complete up to five workouts each week.

Remember, the key to success is to make exercise a regular and enjoyable part of your everyday life.

SUGGESTED STRETCHES

The correct form for several basic stretches is shown in the drawings below. Move slowly as you stretch—never bounce.

1. Toe Touch Stretch

Stand with your knees bent slightly and slowly bend forward from your hips. Allow your back and shoulders to relax as you reach down toward your toes as far as possible. Hold for 15 counts, then relax. Repeat 3 times. Stretches: Hamstrings, back of knees and back.

2. Hamstring Stretch

Sit with one leg extended. Bring the sole of the opposite foot toward you and rest it against the inner thigh of your extended leg. Reach toward your toes as far as possible. Hold for 15 counts, then relax. Repeat 3 times for each leg. Stretches: Hamstrings, lower back and groin.

3. Calf/Achilles Stretch

With one leg in front of the other, reach forward and place your hands against a wall. Keep your back leg straight and your back foot flat on the floor. Bend your front leg, lean forward and move your hips toward the wall. Hold for 15 counts, then relax. Repeat 3 times for each leg. To cause further stretching of the achilles tendons, bend your back leg as well. Stretches: Calves, achilles tendons and ankles.

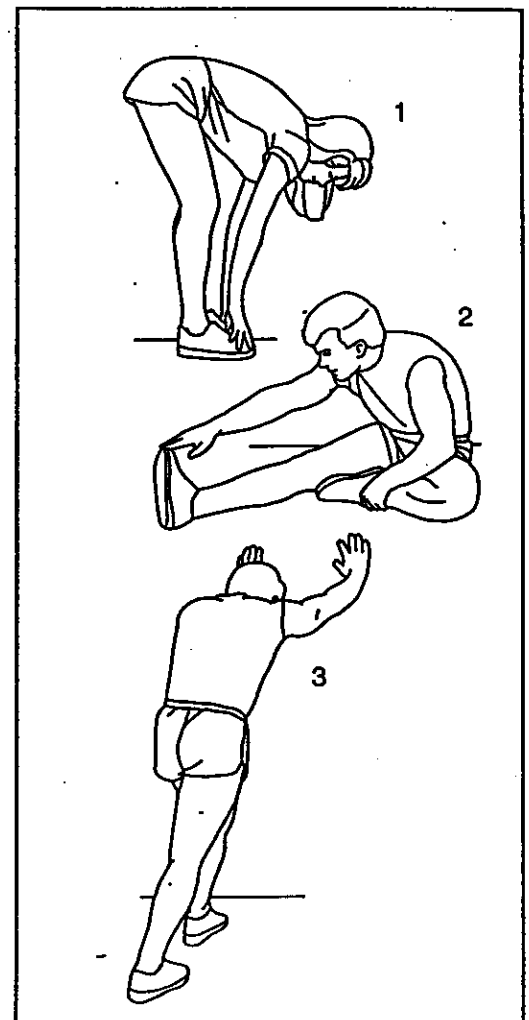

Remove this **HARDWARE IDENTIFICATION CHART**, **EXPLODED DRAWING** and **PART LIST** from the user's manual. Save this page for future reference.

HARDWARE IDENTIFICATION CHART

The chart below is provided to help you identify the small parts used in assembly. The number in parenthesis below each part refers to the key number of the part. The second number refers to the quantity used in assembly. Note: Some small parts may have been pre-assembled for shipping purposes. If a part is not found in the part bag, check to see if it has been pre-assembled.

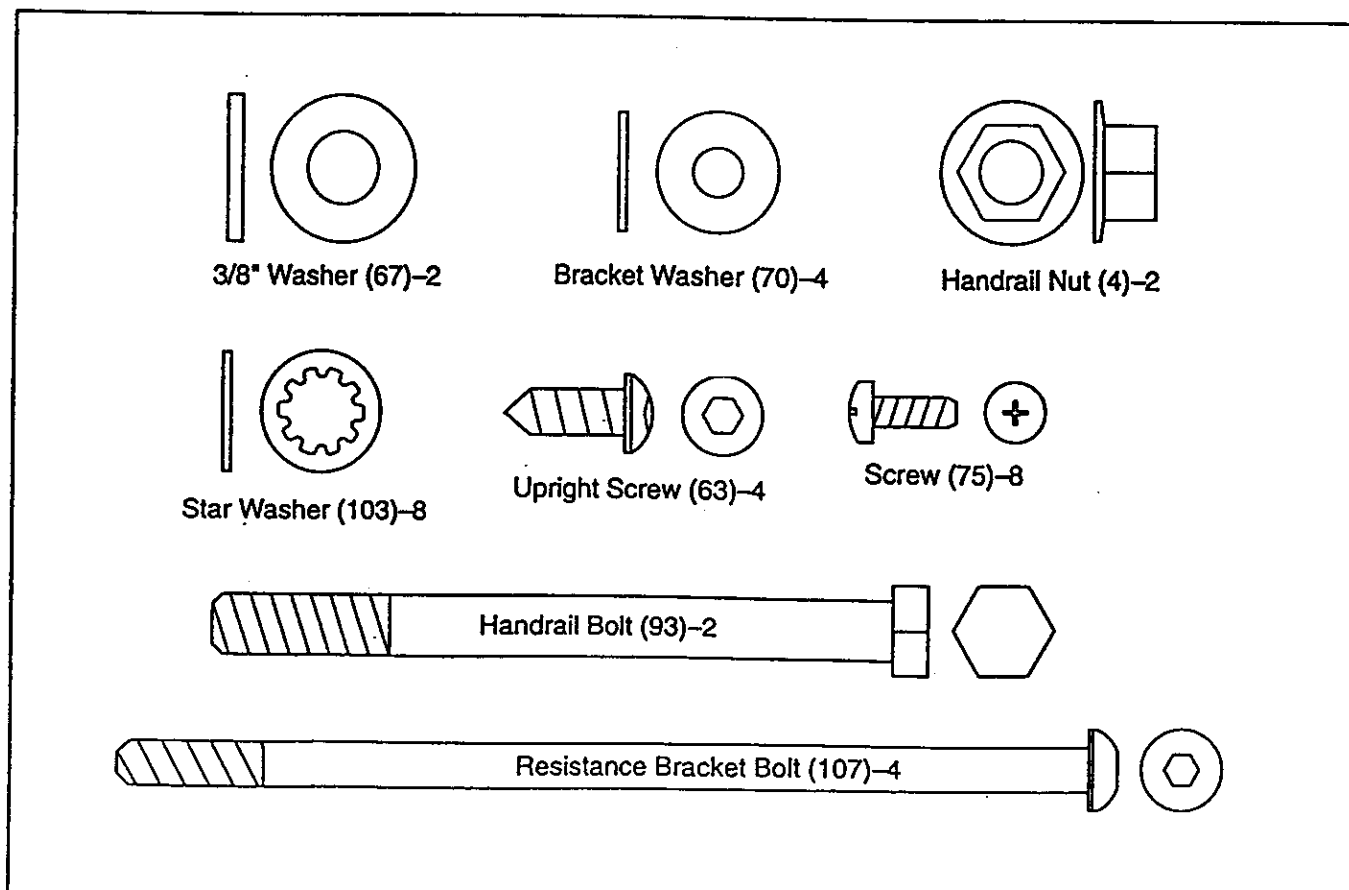

EXPLODED DRAWING—Model No. 831.297380

R0197A

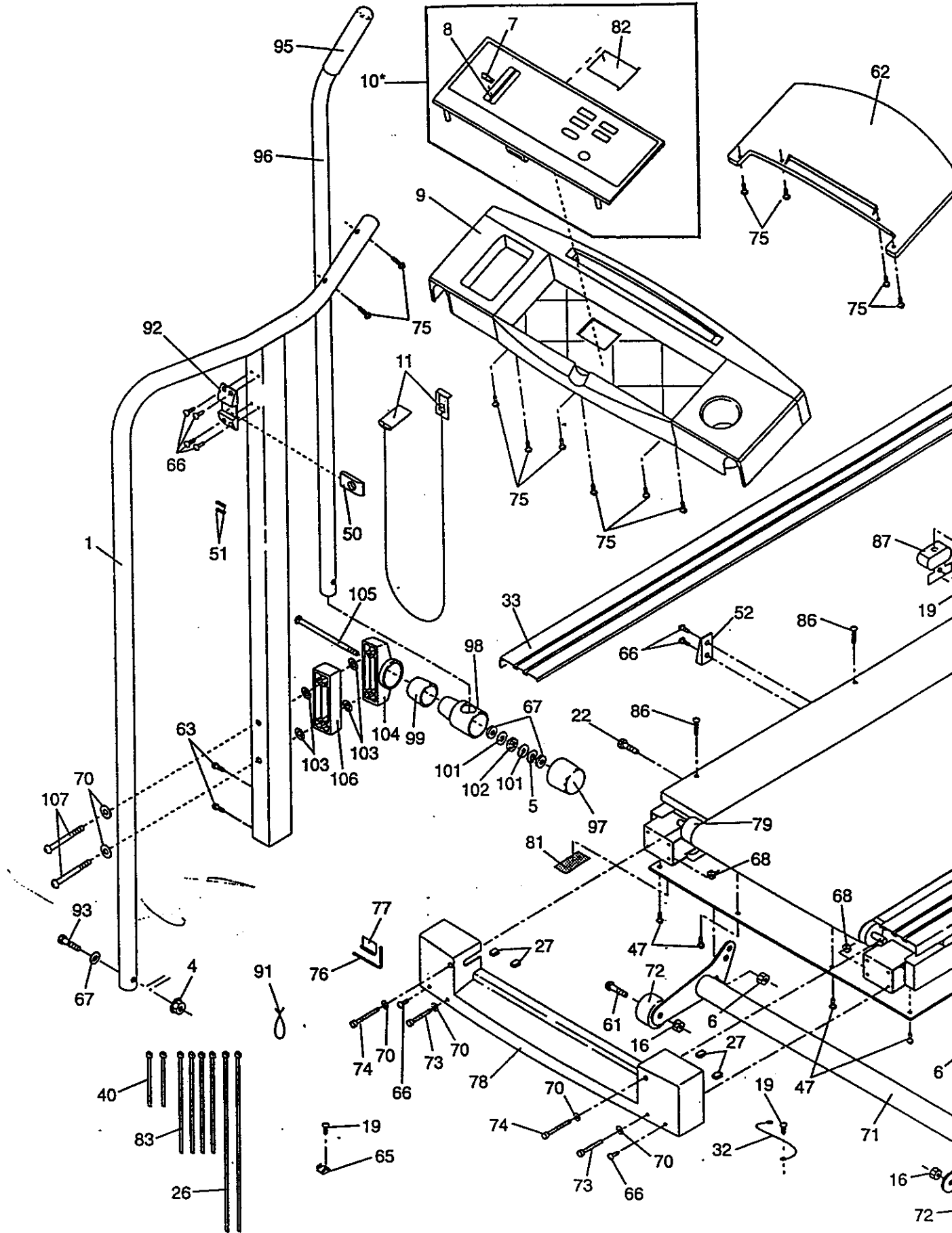

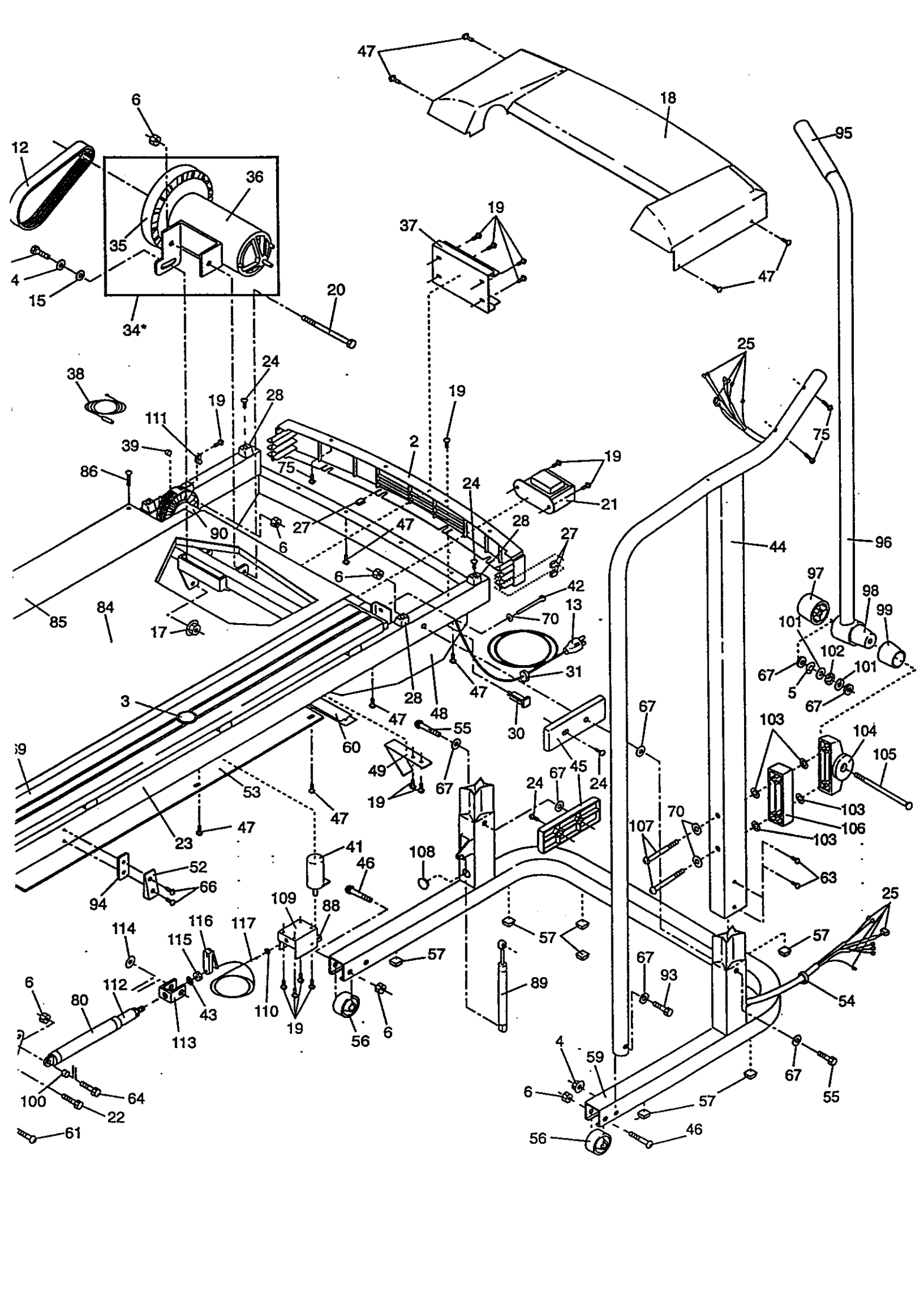

PART LIST—Model No. 831.297380

R0197A

Key No.	Part No.	Qty.	Description	Key No.	Part No.	Qty.	Description
1	135635	1	Left Upright	64	119375	1	Incline Shock Bolt
2	131882	1	Front Frame Cover	65	116927	1	Wire Tie Holder
3	113227	1	Incline Knob Sleeve	66	013141	16	Latch-Frame Guide Screw
4	136012	2	Handrail Nut	67	014132	10	3/8" Washer
5	128005	2	Spring Washer	68	121576	2	Roller Endcap Nut
6	119425	8	3/8" Lock Nut	69	136220	1	Right Foot Rail
7	131161	1	Speed Knob	70	014063	9	Endcap/Bracket Washer
8	128113	1	Speed Potentiometer	71	136015	1	Incline Leg
9	131606	1	Console Base	72	052012	2	Incline Leg Wheel
10*	133961	1	Console	73	013523	2	Rear Roller Endcap Screw
11	119038	1	Key/Clip	74	013342	2	Adjustment Bolt
12	126134	1	Motor Belt	75	126996	14	Screw
13	124669	1	Power Cord	76	128457	1	Allen Wrench
14	122812	1	Motor Tension Washer	77	016028	1	Adhesive Clip
15	014117	1	Motor Tension Star Washer	78	131635	1	Rear Roller Endcap
16	012056	2	Incline Wheel Nut	79	133845	1	Rear Roller
17	120867	1	Motor Tension Nut	80	122002	1	Incline Shock
18	135194	1	Motor Hood	81	131605	1	Latch Decal
19	120630	20	Small Screw	82	129639	1	Battery Cover
20	107503	1	Motor Pivot Bolt	83	016057	4	8" Cable Tie
21	130993	1	Choke	84	131741	1	Walking Belt
22	013307	2	Incline Bolt	85	135633	1	Walking Platform
23	NSP	1	Frame	86	128272	8	Platform Screw
24	013300	6	Anchor Screw	87	131751	8	Isolator
25	133964	1	Wire Harness	88	116435	1	Incline Lever
26	133860	2	15" Wire Tie	89	129814	1	Shock
27	133333	8	Cover Clip	90	133598	1	Front Roller/Pulley
28	113106	4	Hood Anchor	91	116926	8	Releasable Cable Tie
29	013322	12	Frame Cover Screw	92	131753	1	Storage Latch Bracket
30	109382	1	Circuit Breaker	93	124614	2	Handrail Bolt
31	124695	1	Grommet	94	132031	1	Frame Guide Spacer
32	130426	1	Ground Wire	95	105500	2	Foam Grip
33	135530	1	Left Foot Rail	96	136221	2	Upper Body Arm w/Foam
34*	133966	1	Motor/Pulley/Flywheel/Fan	97	126843	2	Resistance Knob
35	126747	1	Pulley/Flywheel/Fan	98	126828	2	Resistance Cone
36	133413	1	Motor	99	126827	2	Resistance Sleeve
37	133599	1	Controller	100	059019	1	Incline Shock Spacer (small)
38	118153	1	Reed Switch	101	102973	4	Thrust Washer
39	100498	1	Magnet	102	106896	2	Thrust Bearing
40	016029	2	4" Cable Tie	103	014149	8	Star Washer
41	116434	1	Incline Knob	104	126773	2	Resistance Bracket
42	112609	1	Front Roller Adj. Bolt	105	126644	2	Resistance Bolt
43	104345	1	Shock Star Washer	106	132583	2	Resistance Bracket Spacer
44	135636	1	Right Upright	107	132637	4	Resistance Bracket Bolt
45	133685	2	Upright Spacer	108	126960	1	Base Plug
46	130868	2	Base Wheel Bolt	109	132648	1	Incline Knob Bracket
47	013162	14	Belly Pan Screw	110	014066	1	Cable Lock Washer
48	131639	1	Belly Pan	111	131090	1	Clamp
49	127098	2	Belt Guide	112	131782	1	Incline Shock Spacer
50	131738	1	Storage Latch	113	133862	1	Shock Bracket
51	129734	2	Storage Latch Spring	114	012155	1	1/2" Push Nut
52	130251	2	Frame Guide	115	012149	1	Shock Nut
53	133605	1	Rear Frame Cover	116	118202	1	Shock Release
54	129004	1	Wire Harness Grommet	117	119919	1	Incline Cable
55	013430	2	Upright Pivot Bolt	#	114953	1	14" Blue Wire, 2 Female
56	129642	2	Base Wheel	#	101897	1	14" White Wire, 2 Female
57	129740	7	Base Pad	#	107771	1	8" White Wire, Male/Female
58	013547	3	Motor Tension Bolt	#	101896	1	4" White Wire, Male/Female
59	136218	1	Base	#	135641	1	User's Manual
60	130822	1	Safety Cover Connector				
61	117806	2	Incline Leg Wheel Bolt				
62	135607	1	Book Rack				
63	013484	4	Upright Screw				

* Includes all parts shown in the box

These parts are not illustrated



Model No. 831.297380

QUESTIONS?

If you find that:

- you need help assembling or operating the PROFORM® CROSSWALK 2.5 treadmill
- a part is missing
- you need to schedule repair service

call our toll-free HELPLINE

1-800-736-6879

Monday–Saturday, 7 am–7 pm
Central Time (excluding holidays)

REPLACEMENT PARTS

If parts become worn and need to be replaced, call the following toll-free number

1-800-FON-PART
(1-800-366-7278)

The model number and serial number of your PROFORM® CROSSWALK 2.5 treadmill are listed on a decal attached to the frame. See the front cover of this manual to find the location of the decal.

All replacement parts are available for immediate purchase or special order when you visit your nearest SEARS Service Center. To request service or to order parts by telephone, call the toll-free numbers listed at the left.

When requesting help or service, or ordering parts, please be prepared to provide the following information:

- The NAME OF THE PRODUCT (PROFORM® CROSSWALK 2.5 treadmill)
- The MODEL NUMBER OF THE PRODUCT (831.297380)
- The PART NUMBER OF THE PART (see the EXPLODED DRAWING and PART LIST included in this manual)
- The DESCRIPTION OF THE PART (see the EXPLODED DRAWING and PART LIST included in this manual).

FULL 90 DAY WARRANTY

For 90 days from the date of purchase, if failure occurs due to defect in material or workmanship in this SEARS TREADMILL EXERCISER, contact the nearest SEARS Service Center throughout the United States and SEARS will repair or replace the TREADMILL EXERCISER, free of charge.

This warranty does not apply when the TREADMILL EXERCISER is used commercially or for rental purposes.

This warranty gives you specific legal rights, and you may also have other rights which vary from state to state.

SEARS, ROEBUCK AND CO., DEPT. 817WA, HOFFMAN ESTATES, IL 60179