

PRO-FORM[®]

7705

STATIONARY BIKE

SEARS

Model No. 831.288250

Serial No. _____

Write the serial number in the space above for future reference.

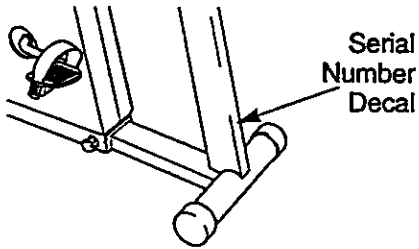

EXERCISE
EQUIPMENT

QUESTIONS

HELPLINE!

1-800-736-6879

Patent Pending

CAUTION

Read all precautions and instructions in this manual before using this equipment. Keep this manual for future reference.

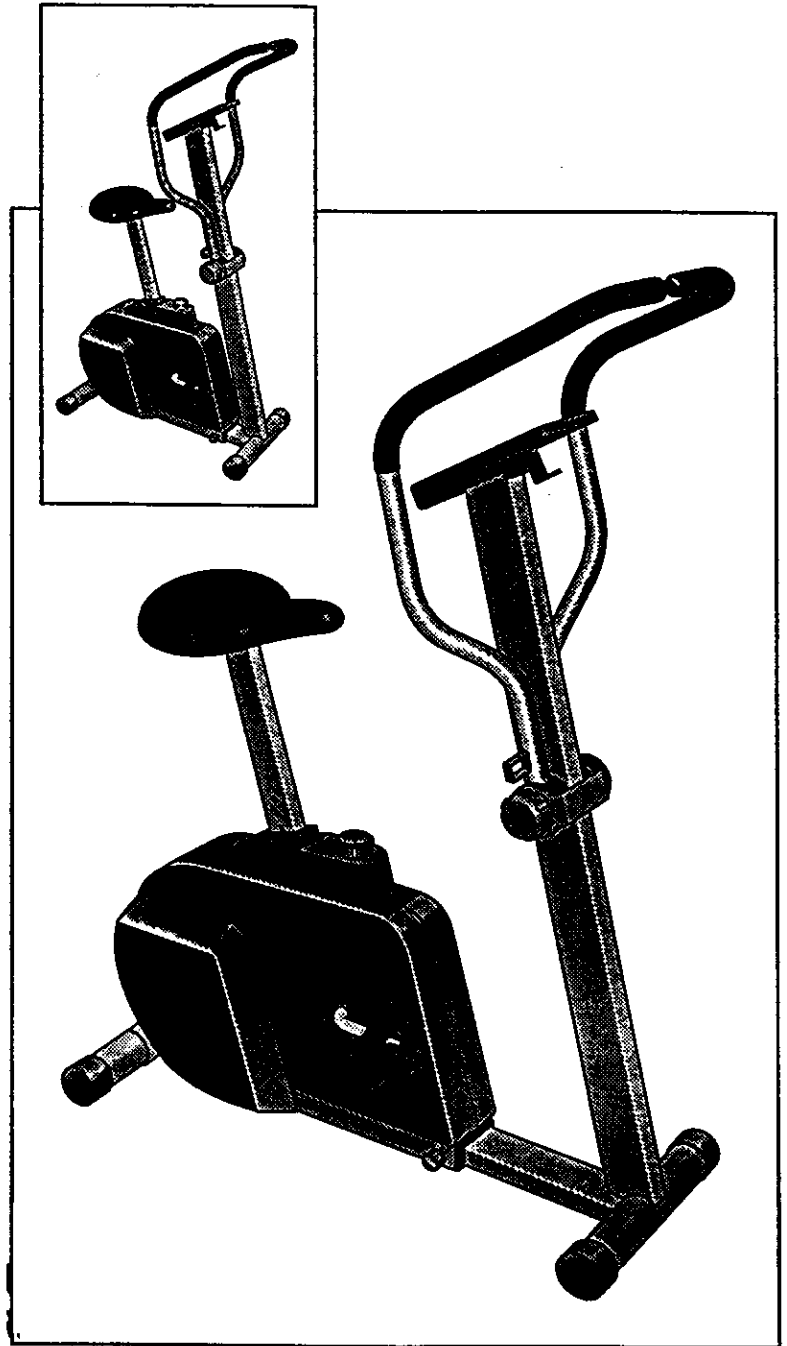

SEARS, ROEBUCK AND CO., HOFFMAN ESTATES, IL 60179

PRO·FORM®

7705

STATIONARY BIKE

FULL 90 DAY WARRANTY

For 90 days from the date of purchase, if failure occurs due to defect in material or workmanship in this SEARS BIKE EXERCISER, contact the nearest SEARS Service Center throughout the United States and SEARS will repair or replace the BIKE EXERCISER, free of charge.

This warranty does not apply when the BIKE EXERCISER is used commercially or for rental purposes.

This warranty gives you specific legal rights, and you may also have other rights which vary from state to state.

SEARS, ROEBUCK AND CO., DEPT. 817WA, HOFFMAN ESTATES, IL 60179

TABLE OF CONTENTS

FULL 90 DAY WARRANTY	2
IMPORTANT PRECAUTIONS	3
BEFORE YOU BEGIN	4
PART IDENTIFICATION CHART	5
ASSEMBLY	6
HOW TO USE THE PROFORM 770S	8
CONDITIONING GUIDELINES	10
MAINTENANCE AND STORAGE	12
NOTES	13
PART LIST	14
EXPLODED DRAWING	15
ORDERING REPLACEMENT PARTS	Back Cover

IMPORTANT PRECAUTIONS

WARNING: To reduce the risk of serious injury, read the following important precautions before using the PROFORM 770S.

1. Read all instructions in this manual before using the 770S. Use the 770S only as described.
2. It is the responsibility of the owner to ensure that all users of the 770S are adequately informed of all precautions.
3. Use the 770S indoors, away from moisture and dust. Position the 770S on a level surface. Place a mat beneath the 770S to protect the floor or carpet.
4. Inspect and tighten all parts regularly. Replace any worn parts immediately.
5. Keep small children and pets away from the 770S at all times.
6. The 770S should not be used by persons weighing more than 250 pounds.
7. Wear appropriate clothing when exercising; do not wear loose clothing that could become caught on the 770S. Always wear athletic shoes for foot protection.
8. When adjusting the seat, insert the seat knob through one of the holes in the seat post (see the drawing on page 4). Do not insert the seat knob under the seat post.
9. Always keep your back straight when using the 770S. Do not arch your back.
10. If you feel pain or dizziness at any time while exercising, stop immediately and begin cooling down.
11. The 770S is intended for in-home use only. Do not use the 770S in a commercial, rental, or institutional setting.

WARNING: Before beginning this or any exercise program, consult your physician. This is especially important for persons over the age of 35 or persons with pre-existing health problems. Read all instructions before using. SEARS assumes no responsibility for personal injury or property damage sustained by or through the use of this product.

BEFORE YOU BEGIN

Thank you for selecting the innovative PROFORM® 770S. The 770S offers a unique form of low-impact exercise that works both the upper body and the lower body for greater cardiovascular benefits and increased muscle toning. The 770S features adjustable resistance to let you tailor your exercise to the level that's perfect for you. And when you're not exercising, the 770S can be folded for compact storage.

For your benefit, read this manual carefully before you use the PROFORM 770S. If you have additional

questions, please call our toll-free HELPLINE at 1-800-736-6879, Monday through Saturday, 7 a.m. until 7 p.m. Central Time (excluding holidays). To help us assist you, please note the product model number and serial number before calling. The model number is 831.288250. The serial number can be found on a decal attached to the 770S (see the front cover of this manual for the location of the decal).



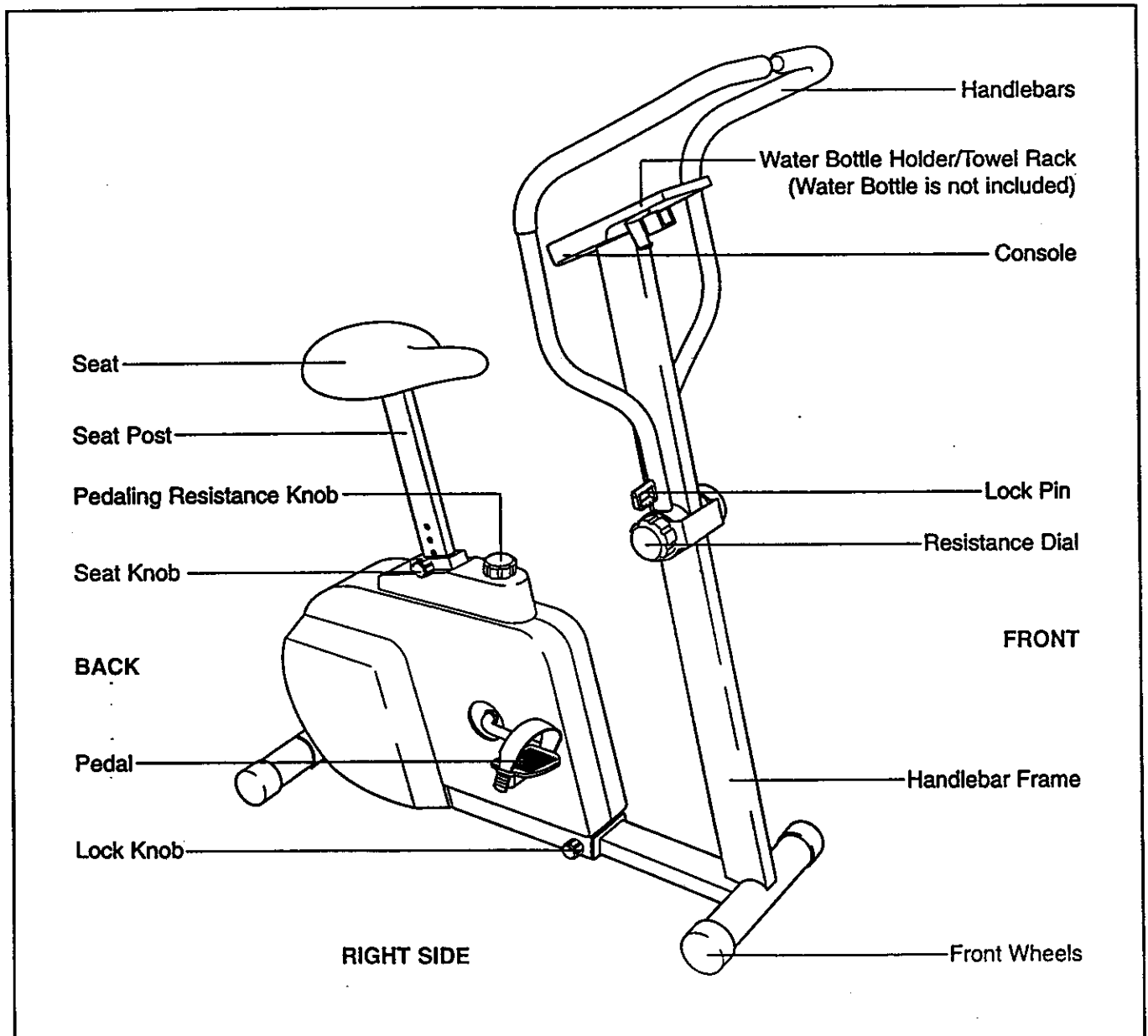



Before reading further, please look at the drawing below and familiarize yourself with the parts that are labeled.

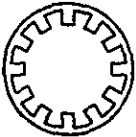

PART IDENTIFICATION CHART

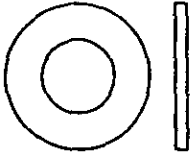

Use the chart below for help identifying the small parts used in assembly. The number in parenthesis below each part refers to the key number of the part. The number after the dash refers to the quantity used

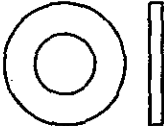
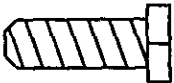
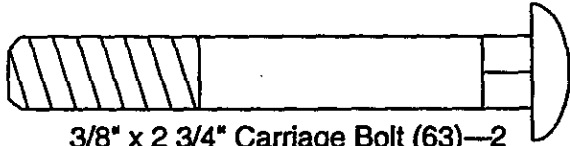
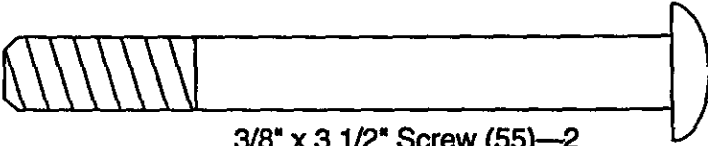
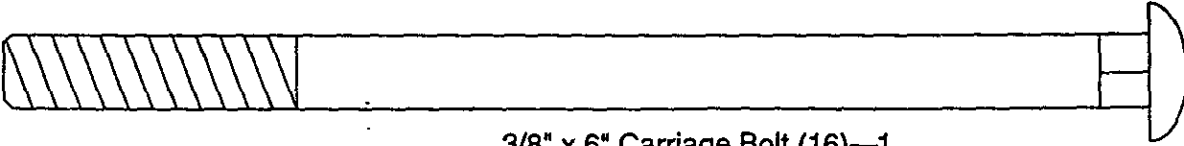
in assembly. Note: Some parts may have been pre-attached for shipping purposes. If a part is not found in the parts bag, check to see if it has been pre-attached.

		
<p>M10 Star Washer (14)—1</p>	<p>M8 Nylon Locknut (46)—4 (May be attached to seat)</p>	<p>3/8" Nylon Locknut (56)—4</p>
		
<p>Console Screw (12)—4 (May be attached to console)</p>	<p>M10 Flat Washer (57)—2</p>	<p>M12 OD Flat Washer (73)—2</p>
		
<p>5/16" Flat Washer (26)—4 (May be attached to seat)</p>	<p>1/4" x 1" Screw (54)—2</p>	<p>3/8" x 2 3/4" Carriage Bolt (63)—2</p>
		
	<p>3/8" x 3 1/2" Screw (55)—2</p>	
		
	<p>3/8" x 6" Carriage Bolt (16)—1</p>	

ASSEMBLY

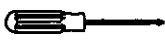
Place all parts of the PROFORM 770S in a cleared area and remove the packing materials. Do not dispose of the packing materials until assembly is completed.

In addition to the included allen wrenches  , assembly requires a phillips screwdriver  and two adjustable wrenches .

1. Refer to drawing 1A. Loosen the Lock Knob (38) on the right side of the Frame (1).

Refer to drawing 1. Slide the Handlebar Frame (2) forward until it stops.

Refer to drawing 1A. Tighten the Lock Knob (38)

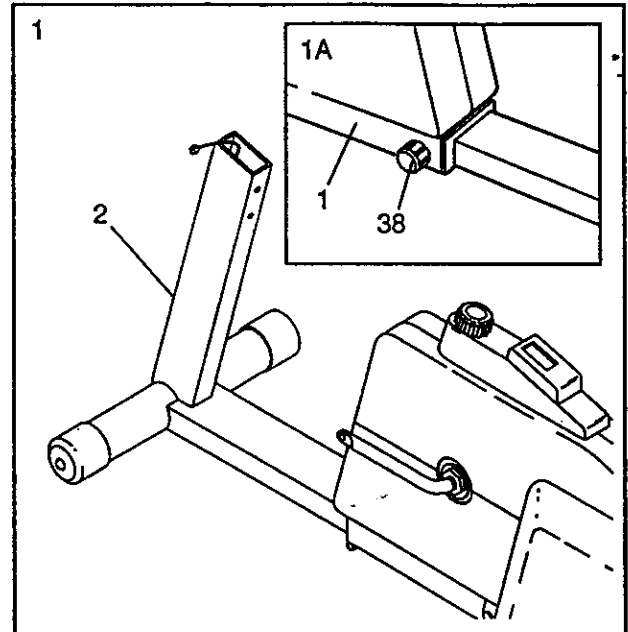

2. Identify the Left Pedal (52); there is an "L" on the Left Pedal for identification. Using an adjustable wrench, tighten the Left Pedal *counterclockwise* into the left arm of the Crank (17). Tighten the Right Pedal (not shown) *clockwise* into the right arm of the Crank.

Adjust the Pedal Strap (15) on the Left Pedal (52) to the desired position. Press the Pedal Strap onto the adjustment tab. Adjust the Pedal Strap on the Right Pedal (not shown) in the same manner.

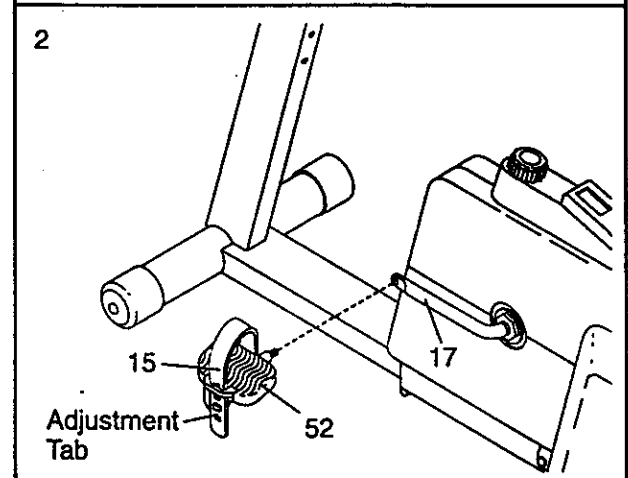

3. Make sure that there is a Stabilizer Endcap (45) on each end of the Stabilizer (9).

Attach the Stabilizer (9) to the Frame (1) with two 3/8" x 2 3/4" Carriage Bolts (63) and two 3/8" Nylon Locknuts (56). Make sure that the Stabilizer is turned so the dimples are in the indicated position.

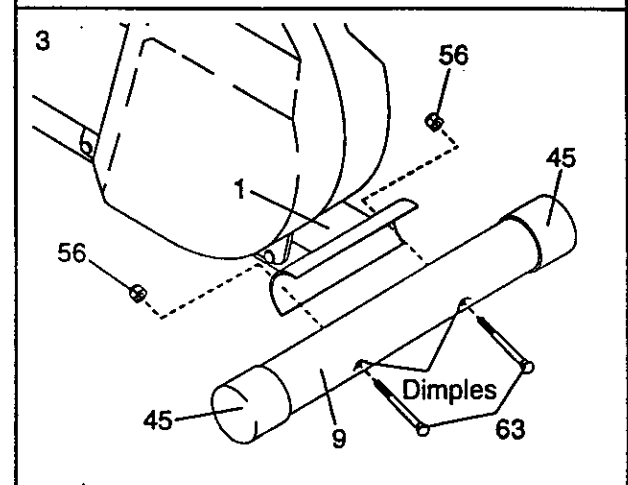

4. Refer to drawing 4A. The Console (58) requires two "AA" batteries (not included). Alkaline batteries are recommended. Press two batteries into the battery clip under the Console. Make sure that the negative (-) ends of the batteries are touching the springs.

Refer to drawing 4. Insert the console wire through the Handlebar Post (4). Attach the Console (58) to the Handlebar Post with four Console Screws (12).

Connect the console wire to the Reed Switch Wire (60) at the top of the Handlebar Frame (2). Insert the Handlebar Post (4) into the Handlebar Frame. Be careful to avoid pinching the wires. Attach the Handlebar Post with two 3/8" x 3 1/2" Screws (55), two M10 Flat Washers (57), and two 3/8" Nylon Locknuts (56).

5. Refer to drawing 5. Remove the four round stickers from the Handlebar Bracket (10) and the Handlebar Post (4). Attach the Handlebar Bracket to the Handlebar Post with two 1/4" x 1" Screws (54) and the two M12 OD Flat Washers (73). Make sure that the square hole is on the left side. Note: This step shows how to assemble the Resistance Dial (11) on the right side of the Handlebar Post (4). To assemble the Resistance Dial on the left side, reverse the orientation of the Resistance Bracket (10), 6" Carriage Bolt (16), M10 Star Washer (14), and Resistance Dial.

Hold the lower end of the Left Handlebar (5) inside the Handlebar Bracket (10). Insert the 3/8" x 6" Carriage Bolt (16) into the Handlebar Bracket and through the Left Handlebar. Hold the Right Handlebar (6) inside the Handlebar Bracket. Insert the Carriage Bolt until the head of the Carriage Bolt is resting in the square hole in the Handlebar Bracket. Slide the M10 Star Washer (14) onto the Carriage Bolt. Tighten the Resistance Dial (11) onto the Carriage Bolt.

Align the holes in the Handlebars (5, 6) with the hole in the Handlebar Post (4). Insert the Lock Pin (53) through the Handlebars and the Handlebar Post. Be careful not to damage the wire inside the Handlebar Post.

6. Insert the Seat Post (3) into the Frame (1). Align one of the holes in the Seat Post with the hole in the Frame. Insert the Seat Knob (37) into the Frame and the Seat Post, and tighten the Seat Knob into the Frame. Make sure to insert the Seat Knob through one of the holes in the Seat Post; do not insert the Seat Knob under the Seat Post.

Attach the Seat (36) to the Seat Post (3) with four M8 Nylon Locknuts (46) and four 5/16" Flat Washers (26). (Note: The Nylon Locknuts and Flat Washers may be preattached to the bottom of the Seat.)

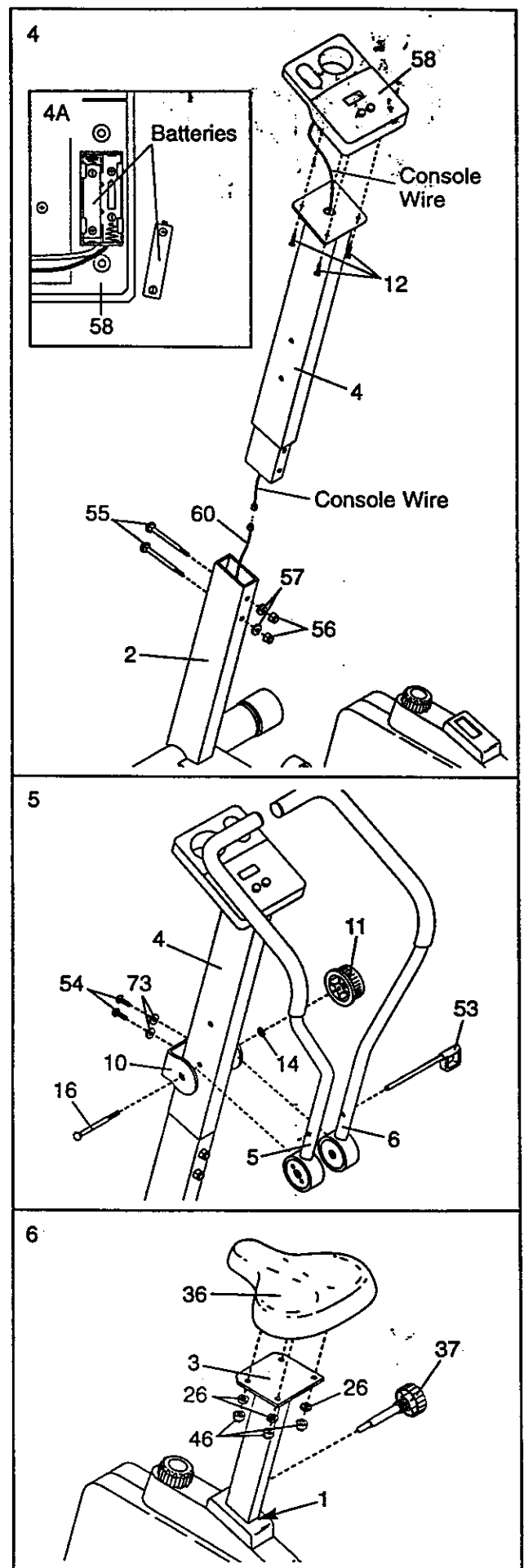

HOW TO USE THE PROFORM 770S

HOW TO ADJUST THE SEAT

For effective exercise, the Seat (36) should be at the proper height. As you pedal, there should be a slight bend in your knees when the pedals are at the lowest position. To adjust the Seat, first hold the Seat and unscrew the Seat Knob (37). Align one of the holes in the Seat Post (3) with the hole in the Frame (1). Insert the Seat Knob (37) into the Frame and the Seat Post, and tighten the Seat Knob into the Frame. Make sure to insert the Seat Knob through one of the holes in the Seat Post; do not insert the Seat Knob under the Seat Post.

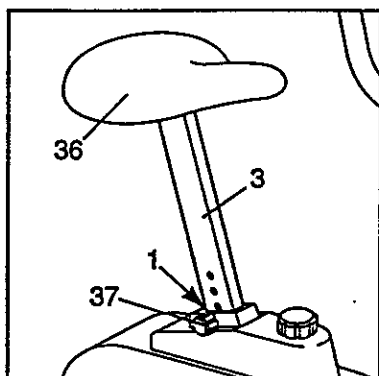

HOW TO ADJUST THE PEDAL STRAPS

To adjust each Pedal Strap (13), first pull the end of the Pedal Strap off the adjustment tab on the Pedal (51). Align a different hole in the Pedal Strap with the adjustment tab. Press the Pedal Strap onto the adjustment tab.

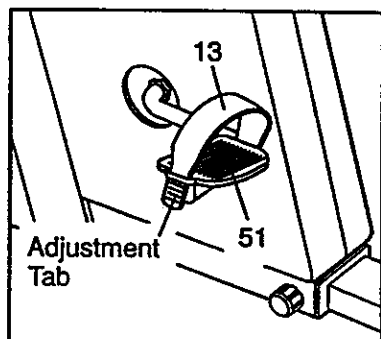

HOW TO ADJUST THE PEDALING RESISTANCE

The pedaling resistance can be adjusted using the Resistance Knob (40) located at the base of the seat post. To increase the resistance, turn the Resistance Knob clockwise; to decrease the resistance, turn the Resistance Knob counterclockwise.

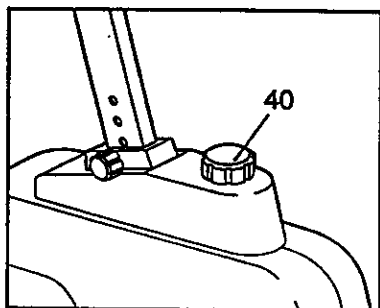

HOW TO USE THE HANDLEBARS IN THE STATIONARY POSITION

The Handlebars (5, 6) can be used in either the stationary position or the dual-motion position. To use the Handlebars in the stationary position, align the holes in the Handlebars with the hole in the Handlebar Post (4). Insert the Lock Pin (53) through the Handlebars and the Handlebar Post. Note: If it is difficult to insert the Lock Pin, twist the Handlebars slightly in order to align the holes. Next, tighten the Resistance Dial (11) (see the drawing above).

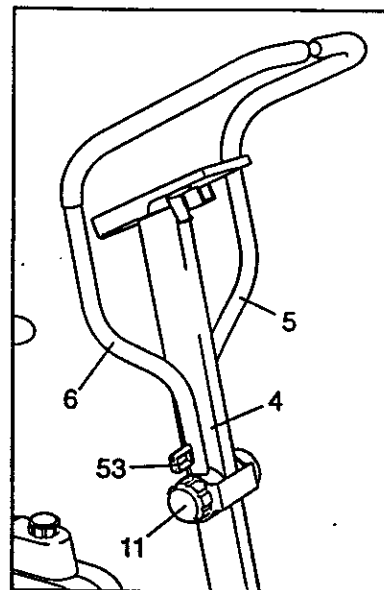

HOW TO USE THE HANDLEBARS IN THE DUAL-MOTION POSITION

To use the Handlebars (5, 6) in the dual-motion position, remove the Lock Pin (53) from the Handlebars and the Handlebar Post (4). Keep the Lock Pin in a safe place. The resistance of the Handlebars can be adjusted with the Resistance Dial (11). To increase the resistance, turn the Resistance Dial clockwise; to decrease the resistance, turn the Resistance Dial counterclockwise.

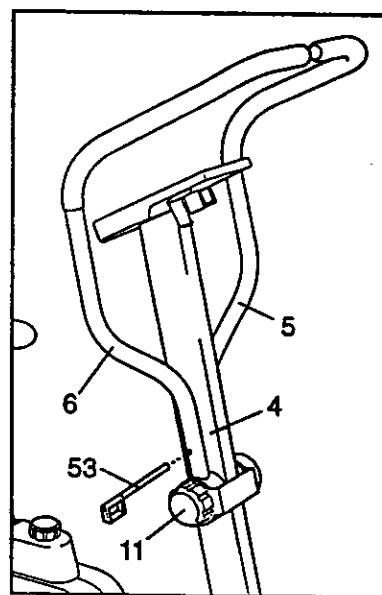

To exercise, move the Handlebars (5, 6) forward and backward as you pedal. Be sure to keep your back straight and your knees bent slightly.

DESCRIPTION OF THE CONSOLE

The console features five modes that provide instant exercise feedback during your workouts. The modes are described below.

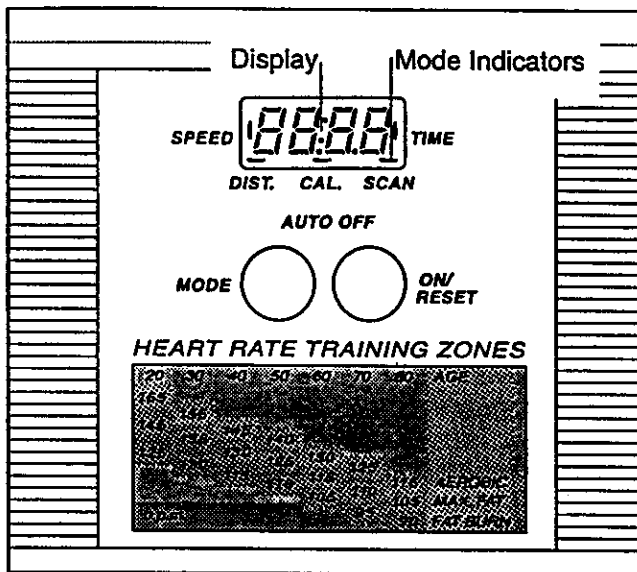

- **Speed**—Displays your pedaling speed, in miles per hour.
- **Time**—Displays the length of time you have exercised. Note: If you stop pedaling for ten seconds or longer, the time mode will pause until you resume.
- **Distance**—Displays the total number of miles you have pedaled, up to 999. The display will then reset to zero and continue counting.
- **Calorie**—Displays the approximate number of Calories you have burned.
- **Scan**—Displays the speed, time, distance, and calorie modes, for 5 seconds each, in a repeating cycle.

BATTERY INSTALLATION

Before the console can be operated, two "AA" batteries must be installed. If you have not installed batteries, see assembly step 4 on page 7.

HOW TO OPERATE THE CONSOLE

1. To turn on the power, press the on/reset button or simply begin pedaling. When the power is turned on, the entire display will appear for two seconds. The console will then be ready for operation.

2. Select one of the five modes:

Scan mode—When the power is turned on, the scan mode will automatically be selected. One mode indicator will show that the scan mode is selected, and a flashing mode indicator will show which mode is currently displayed. Note: If a different mode is selected, you can select the scan mode again by repeatedly pressing the mode button.

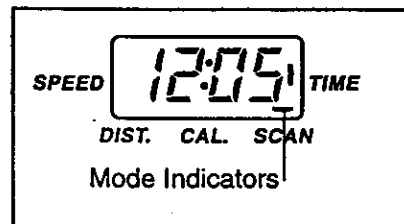

Speed, time, distance or calorie mode—To select one of these modes for continuous display, repeatedly press the mode button. The mode indicators will show which mode is selected. (Make sure that the scan mode is not selected.)

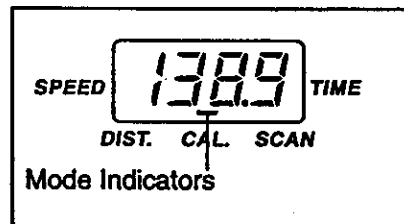

3. To reset the display, press the on/reset button.

4. To turn off the power, simply wait for about four minutes. Note: The console has an "auto-off" feature. If the pedals are not moved and the console buttons are not pressed for four minutes, the power will turn off automatically in order to conserve the batteries.

CONDITIONING GUIDELINES

The following general guidelines will help you to plan your exercise program. Remember that proper nutrition and adequate rest are essential for successful results.

WARNING: Before beginning this or any exercise program, consult your physician. This is especially important for persons over the age of 35 or persons with pre-existing health problems.

EXERCISE INTENSITY

Whether your goal is to burn fat or strengthen your cardiovascular system, the key to achieving the desired results is to exercise with the proper intensity. The proper intensity level can be found by using your heart rate as a guide. The chart below shows recommended heart rates for fat burning, maximum fat burning, and cardiovascular (aerobic) exercise.

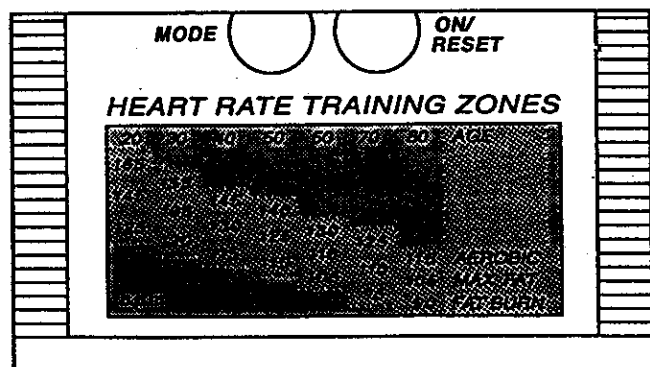

To find the proper heart rate for you, first find your age near the top of the chart (ages are rounded off to the nearest ten years). Next, look below your age and find the three numbers in grey boxes. The three numbers are your "training zone." The lowest number is the recommended heart rate for fat burning; the middle number is the recommended heart rate for maximum fat burning; the highest number is the recommended heart rate for aerobic exercise.

Fat Burning

To burn fat effectively, you must exercise at a relatively low intensity level for a sustained period of time. During the first few minutes of exercise, your body uses easily accessible *carbohydrate* calories for energy. Only after the first few minutes of exercise does your body begin to use stored *fat* calories for energy. If your goal is to burn fat, adjust the intensity of your

exercise until your heart rate is near the lowest number in your training zone as you exercise.

For maximum fat burning, adjust the intensity of your exercise until your heart rate is near the middle number in your training zone as you exercise.

Aerobic Exercise

If your goal is to strengthen your cardiovascular system, your exercise must be "aerobic." Aerobic exercise is activity that requires large amounts of oxygen for prolonged periods of time. This increases the demand on the heart to pump blood to the muscles, and on the lungs to oxygenate the blood. For aerobic exercise, adjust the intensity of your exercise until your heart rate is near the highest number in your training zone.

HOW TO MEASURE YOUR HEART RATE

To measure your heart rate, first exercise for at least four minutes. Then, stop exercising and place two fingers on your wrist as

shown. Take a six-second heartbeat count, and multiply the result by 10 to find your heart rate. For example, if your six-second heartbeat

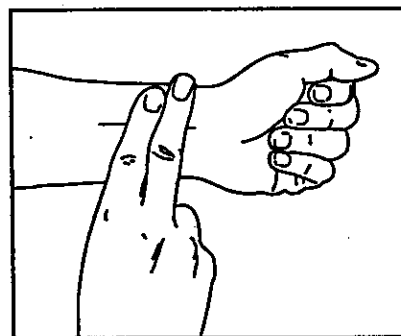

count is 14, your heart rate is 140 beats per minute. (A six-second count is used because your heart rate will drop rapidly when you stop exercising.)

Adjust the intensity of your exercise until your heart rate is at the desired level. You can adjust the intensity of your exercise by changing your pedaling speed, adjusting the pedaling resistance, or using the handlebars in the dual-motion position.

WORKOUT GUIDELINES

Each workout should include the following three parts:

A warm-up, lasting 5 to 10 minutes. Begin with slow, controlled stretches, and progress to more rhythmic stretches to increase the body temperature, heart rate, and circulation in preparation for strenuous exercise. (See SUGGESTED STRETCHES on page 11.)

Training zone exercise, consisting of 20 to 30 minutes of exercising with your heart rate in your training zone.

A cool-down, with 5 to 10 minutes of stretching. Thorough stretching helps to offset problems caused when you stop exercising suddenly. Stretching for increased flexibility is also most effective after exercising. A proper cool-down should leave you relaxed and comfortably tired.

EXERCISE FREQUENCY

To maintain or improve your condition, plan three workouts each week, with at least one day of rest between workouts. After a few months of regular exercise, you may complete up to five workouts each week, if desired.

Remember, the key to success is make exercise a regular and enjoyable part of your everyday life.

SUGGESTED STRETCHES

The correct form for several basic stretches is shown in the drawings below. Move slowly as you stretch—never bounce.

1. Toe Touch Stretch

Stand with your knees bent slightly and slowly bend forward from your hips. Allow your back and shoulders to relax as you reach down toward your toes as far as possible. Hold for 15 counts, then relax. Repeat 3 times. Stretches: Hamstrings, back of knees and back.

2. Hamstring Stretch

Sit with one leg extended. Bring the sole of the opposite foot toward you and rest it against the inner thigh of your extended leg. Reach toward your toes as far as possible. Hold for 15 counts, then relax. Repeat 3 times for each leg. Stretches: Hamstrings, lower back and groin.

3. Calf/Achilles Stretch

With one leg in front of the other, reach forward and place your hands against a wall. Keep your back leg straight and your back foot flat on the floor. Bend your front leg, lean forward and move your hips toward the wall. Hold for 15 counts, then relax. Repeat 3 times for each leg. To cause further stretching of the achilles tendons, bend your back leg as well. Stretches: Calves, achilles tendons and ankles.

4. Quadriceps Stretch

With one hand against a wall for balance, reach back and grasp one foot with your other hand. Bring your heel as close to your buttocks as possible. Hold for 15 counts, then relax. Repeat 3 times for each leg. Stretches: Quadriceps and hip muscles.

5. Inner Thigh Stretch

Sit with the soles of your feet together and your knees outward. Pull your feet toward your groin area as far as possible. Hold for 15 counts, then relax. Repeat 3 times. Stretches: Quadriceps and hip muscles.

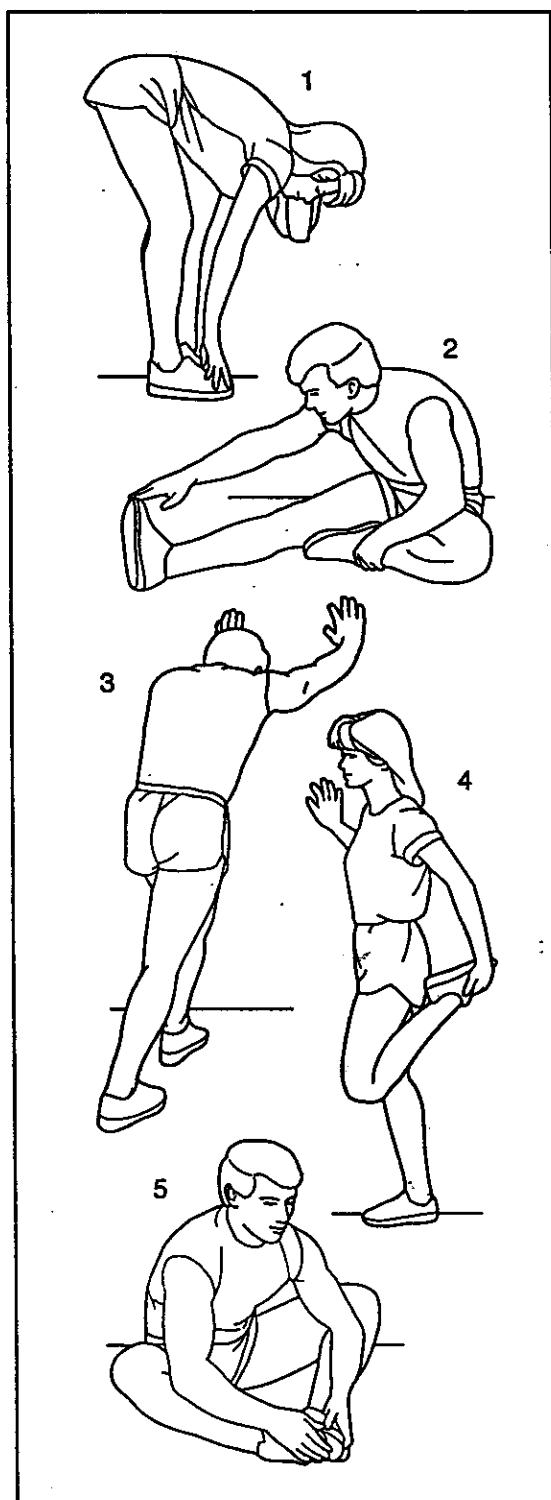

MAINTENANCE AND STORAGE

Inspect and tighten all parts of the PROFORM 770S regularly. The 770S can be cleaned with a soft, damp cloth. To prevent damage to the console, keep liquids away from the console and keep the console out of direct sunlight.

BATTERY REPLACEMENT

If the console does not function properly, the batteries should be replaced. To replace the batteries, see assembly step 4 on page 7.

HANDLEBAR LUBRICATION

If a squeak is heard when the Handlebars (5, 6) are moved, a small amount of grease should be applied.

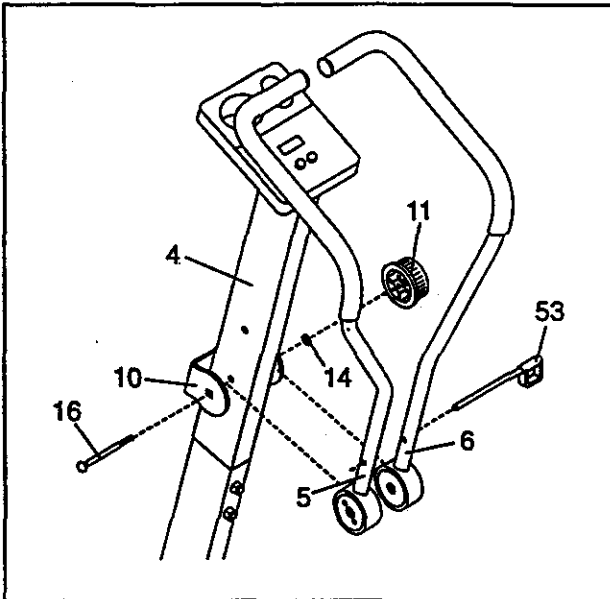

Remove the Lock Pin (53). Turn the Resistance Dial (11) counterclockwise and remove it. Remove the M10 Star Washer (14). Using pliers, grip the head of the 3/8" x 6" Carriage Bolt (16) and remove it. Apply a thin film of grease to both sides of the Handlebar Housings (72). Reattach all parts, making sure that they are in the positions shown.

CRANK ADJUSTMENT

If the arms of the Crank (17) become loose, they should be tightened in order to prevent excessive wear. Loosen the Crank Nut (24) on the left arm of the Crank. Place the end of a standard screwdriver in one of the slots in the Slotted Crank Nut (22). Lightly tap the screwdriver with a hammer to turn the Slotted Crank Nut counterclockwise until the arms are no longer loose. Do not overtighten the Slotted Crank Nut. When the Slotted Crank Nut is properly tightened, tighten the Crank Nut.

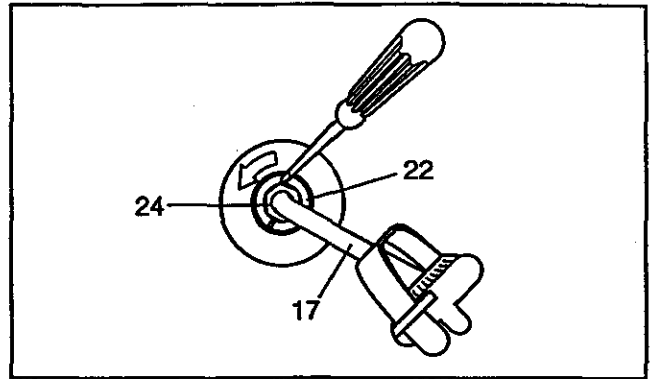

HOW TO STORE THE PROFORM 770S

When the 770S is not in use, it can be folded for compact storage. Refer to the drawing below. Loosen the Lock Knob (38). Slide the Handlebar Frame (2) into the Frame (1) as far as it will go. Tighten the Lock Knob. Store the 770S indoors, away from moisture and dust.

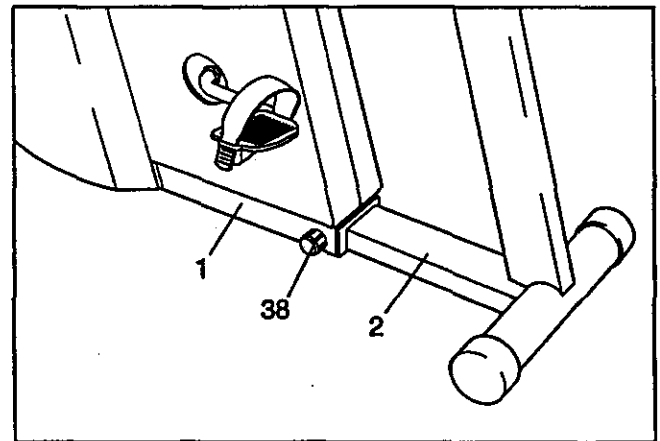

NOTES

PART LIST—Model No. 831.288250

R1196A

Key No.	Part No.	Qty.	Description	Key No.	Part No.	Qty.	Description
1	NSP	1	Frame	40	134274	1	Tension Assembly
2	NSP	1	Handlebar Frame	41	124819	2	Handlebar Endcap
3	134372	1	Seat Post	42	013225	1	M5 Screw
4	134251	1	Handlebar Post	43	109926	1	Rubber Grommet
5	134371	1	Left Handlebar	44	134275	2	Foam Grip
6	134370	1	Right Handlebar	45	134276	2	Stabilizer Endcap
7	134254	1	Idler Bracket	46	012042	7	M8 Nylon Locknut
8	134255	1	Idler Wheel	47	134277	1	Handlebar Frame Bushing
9	134256	1	Stabilizer	48	134278	1	Frame Bushing
10	134257	1	Handlebar Bracket	49	134308	1	Seat Post Bushing
11	134258	1	Resistance Dial	50	013576	1	#8 x 1/2" Screw
12	013141	4	Console Screw	51	134367	1	Right Pedal
13	134259	1	Right Pedal Strap	52	134368	1	Left Pedal
14	104345	1	M10 Star Washer	53	109855	1	Lock Pin
15	134260	1	Left Pedal Strap	54	123713	2	1/4" x 1" Screw
16	134261	1	3/8" x 6" Carriage Bolt	55	123494	2	3/8" x 31/2" Screw
17	134377	1	Crank	56	012149	5	3/8" Nylon Locknut
18	122898	1	Pulley	57	014132	2	M10 Flat Washer
19	018001	2	Bearing	58	132827	1	Console
20	019003	2	Bearing Cup	59	134312	1	Idler Spring
21	014009	1	Keyed Washer	60	133472	1	Reed Switch Wire
22	012010	1	7/8" Slotted Crank Nut	61	128348	1	Push Nut
23	012011	1	15/16" Slotted Crank Nut	62	014008	1	Flat Crank Washer
24	012012	1	7/8" Crank Nut	63	122548	2	3/8" x 2 3/4" Crg. Bolt
25	134263	1	Flywheel Assembly	64	134314	1	Flywheel Axle
26	014041	8	5/16" Flat Washer	65	119222	1	Spacer
27	134374	1	Left Side Shield	66	134316	2	Wheel Screw
28	134375	1	Right Side Shield	67	134317	1	Magnet Bracket
29	135426	10	Side Shield Screw	68	134366	2	M8 x 60mm Screw
30	127597	5	Fastener	69	012150	2	M8 Nut
31	134266	1	Top Shield	70	106106	1	Extension Spring
32	132699	1	Belt	71	013547	1	Idler Pivot Bolt
33	134267	2	Wheel Hub	72	134376	1	Handlebar Housing
34	134268	2	Wheel	73	125206	2	M12 OD Flat Washer
35	134269	2	Wheel Bushing	74	135425	1	Axle Bushing
36	134270	1	Seat	#	134321	1	User's Manual
37	134271	1	Seat Knob	#	045028	1	Socket Tool
38	134272	1	Lock Knob	#	100017	1	Multi-Tool
39	134273	2	Friction Pad	#	045017	1	Allen Wrench

Note: "#" indicates a non-illustrated part. Specifications are subject to change without notice. See the back cover of this manual for information about ordering replacement parts.

EXPLODED DRAWING—Model No. 831.288250

R1196A

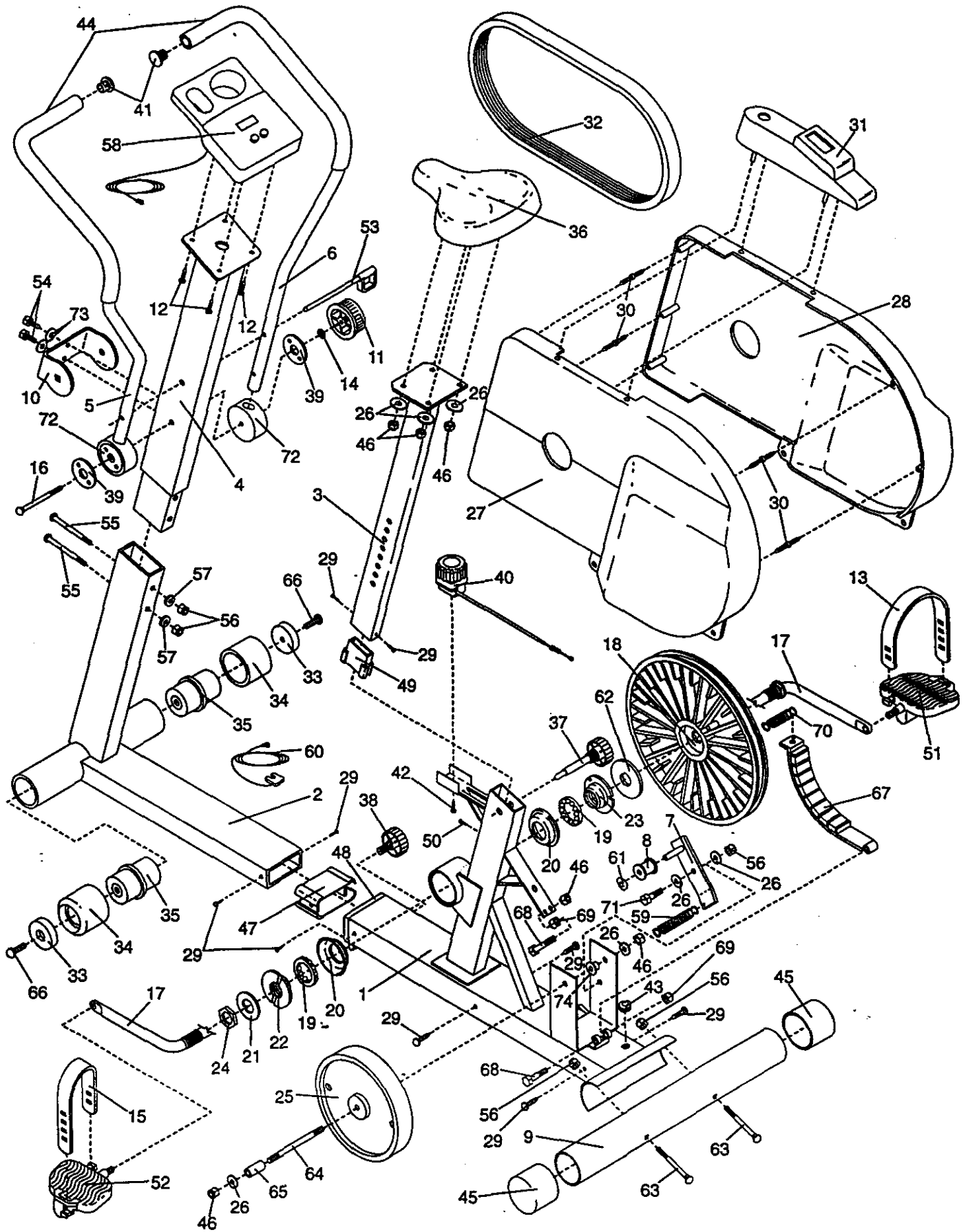



Model No. 831.288250

QUESTIONS?

If you find that:

- you need help assembling or operating the PROFORM 770S
- a part is missing
- or you need to schedule repair service

call our toll-free HELPLINE

1-800-736-6879

Monday–Saturday, 7 am–7 pm
Central Time (excluding holidays)

REPLACEMENT PARTS

If parts become worn and need to be replaced, call the following toll-free number

1-800-FON-PART
(1-800-366-7278)

The model number and serial number of your PROFORM® 770S are listed on a decal attached to the frame. See the front cover of this manual to find the location of the decal.

All replacement parts are available for immediate purchase or special order when you visit your nearest SEARS Service Center. To request service or to order parts by telephone, call the toll-free numbers listed at the left.

When requesting help or service, or ordering parts, please be prepared to provide the following information:

- The NAME OF THE PRODUCT (PROFORM® 770S)
- The MODEL NUMBER OF THE PRODUCT (831.288250)
- The PART NUMBER OF THE PART (see page 14)
- The DESCRIPTION OF THE PART (see page 14)