

**PRO**

# 335

PATENT PENDING

## USER'S MANUAL

# WEIDER®

Model No. 831.150380

Serial No. \_\_\_\_\_

The serial number can be found in the location shown below. Write the serial number in the space above.

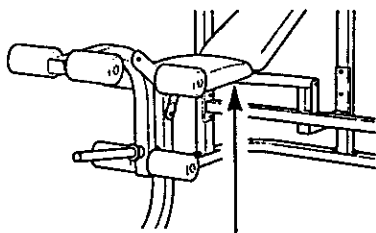

Serial Number Decal (under seat)

EXERCISE  
EQUIPMENT

QUESTIONS

HELPLINE!

1-800-736-6879

### CAUTION

Read all precautions and instructions in this manual before using this equipment. Save this manual for future reference.

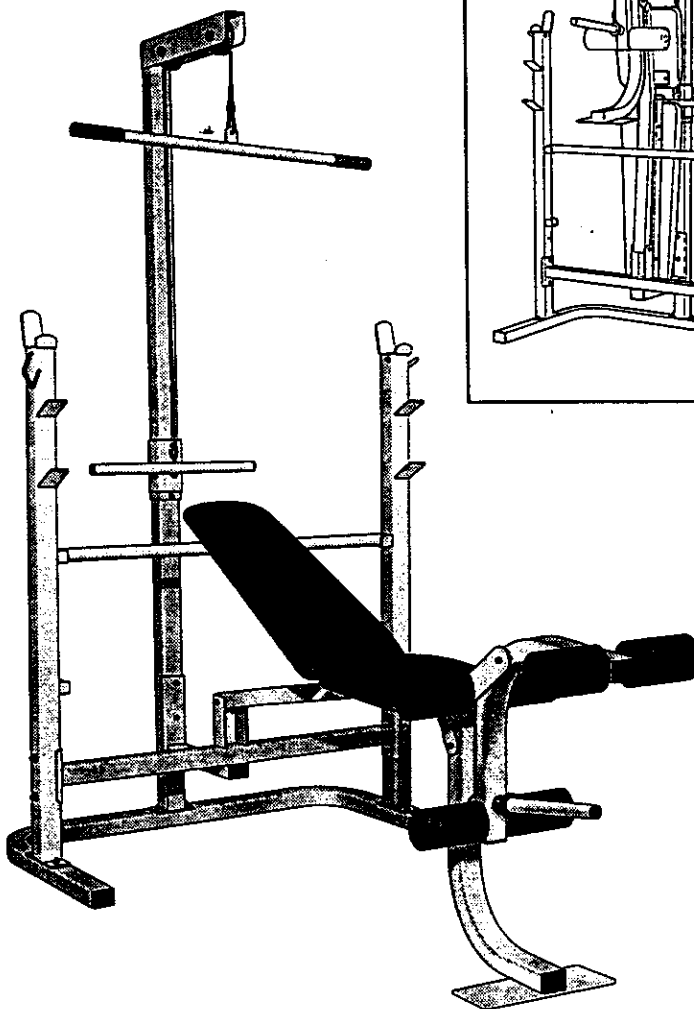
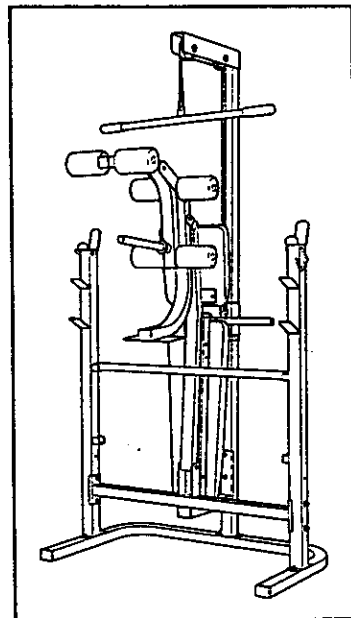

# SEARS

SEARS, ROEBUCK AND CO., HOFFMAN ESTATES, IL 60179

# TABLE OF CONTENTS

FULL 90 DAY WARRANTY .....	2
IMPORTANT PRECAUTIONS .....	3
BEFORE YOU BEGIN .....	4
PART IDENTIFICATION CHART .....	5
ASSEMBLY .....	6
ADJUSTING THE WEIDER PRO 335 .....	12
EXERCISE GUIDELINES .....	14
PART LIST .....	18
EXPLODED DRAWING .....	19
ORDERING REPLACEMENT PARTS .....	Back Cover

## FULL 90 DAY WARRANTY

For 90 days from the date of purchase, if failure occurs due to defect in material or workmanship in this SEARS WEIGHT BENCH EXERCISER, contact the nearest SEARS Service Center throughout the United States and SEARS will repair or replace the WEIGHT BENCH EXERCISER, free of charge.

This warranty does not apply when the WEIGHT BENCH EXERCISER is used commercially or for rental purposes.

This warranty gives you specific legal rights, and you may also have other rights which vary from state to state.

**SEARS, ROEBUCK AND CO., DEPT. 817WA, HOFFMAN ESTATES, IL 60179**

# IMPORTANT PRECAUTIONS

**WARNING:** To reduce the risk of serious injury, read the following important precautions before using the weight bench.

1. Read all instructions in this manual before using the weight bench.
2. Use the weight bench only as described in this manual.
3. Use the weight bench only on a level surface. Cover the floor beneath the weight bench for protection.
4. Inspect and tighten all parts each time you use the weight bench. Replace any worn parts immediately.
5. Keep small children and pets away from the weight bench at all times.
6. Always be sure there is an equal amount of weight on each side of your barbell (not included) when you are using it.
7. When you are using the weight carriage, be sure there is an equal amount of weight on each side of the weight tube.
8. Always wear athletic shoes for foot protection while exercising.
9. Keep hands and feet away from moving parts.
10. The weight bench does not include weights. The weight bench is designed to support a maximum of 510 pounds, including the user, a weight bar and weights. Do not place more than 310 pounds, including a weight bar and weights, on the weight rests. Do not place more than 150 pounds on the weight carriage; use no more than 50 pounds for ab crunches. Do not place more than 150 pounds on the leg lever.
11. When using the backrest, make sure that the adjustment tube is firmly seated in the adjustment brackets on the uprights.
12. If you feel pain or dizziness at any time while exercising, stop immediately and begin cooling down.
13. It is the responsibility of the owner to ensure that all users of the weight bench are adequately informed of all precautions.

**WARNING:** Before beginning this or any exercise program, consult your physician. This is especially important for persons over the age of 35 or persons with pre-existing health problems. Read all instructions before using. SEARS assumes no responsibility for personal injury or property damage sustained by or through the use of this product.

# BEFORE YOU BEGIN

Thank you for selecting the WEIDER® PRO 335 Weight Bench. The versatile PRO 335 Weight Bench is designed to be used with your own weight set (not included) to develop every major muscle group of the body. Whether your goal is a shapely figure, dramatic muscle size and strength, or a healthier cardiovascular system, the PRO 335 Weight Bench will help you to achieve the specific results you want.

**For your benefit, read this manual carefully before using the WEIDER® PRO 335 Weight Bench. If you have additional questions, please call our toll-free**

**HELPLINE at 1-800-736-6879, Monday through Saturday, 7 a.m. until 7 p.m. Central Time (excluding holidays). To help us assist you, please note the product model number and serial number before calling. The model number is 831.150380. The serial number can be found on a decal attached to the PRO 335 weight bench (see the front cover of this manual).**

Before reading further, please review the drawing below and familiarize yourself with the parts that are labeled.

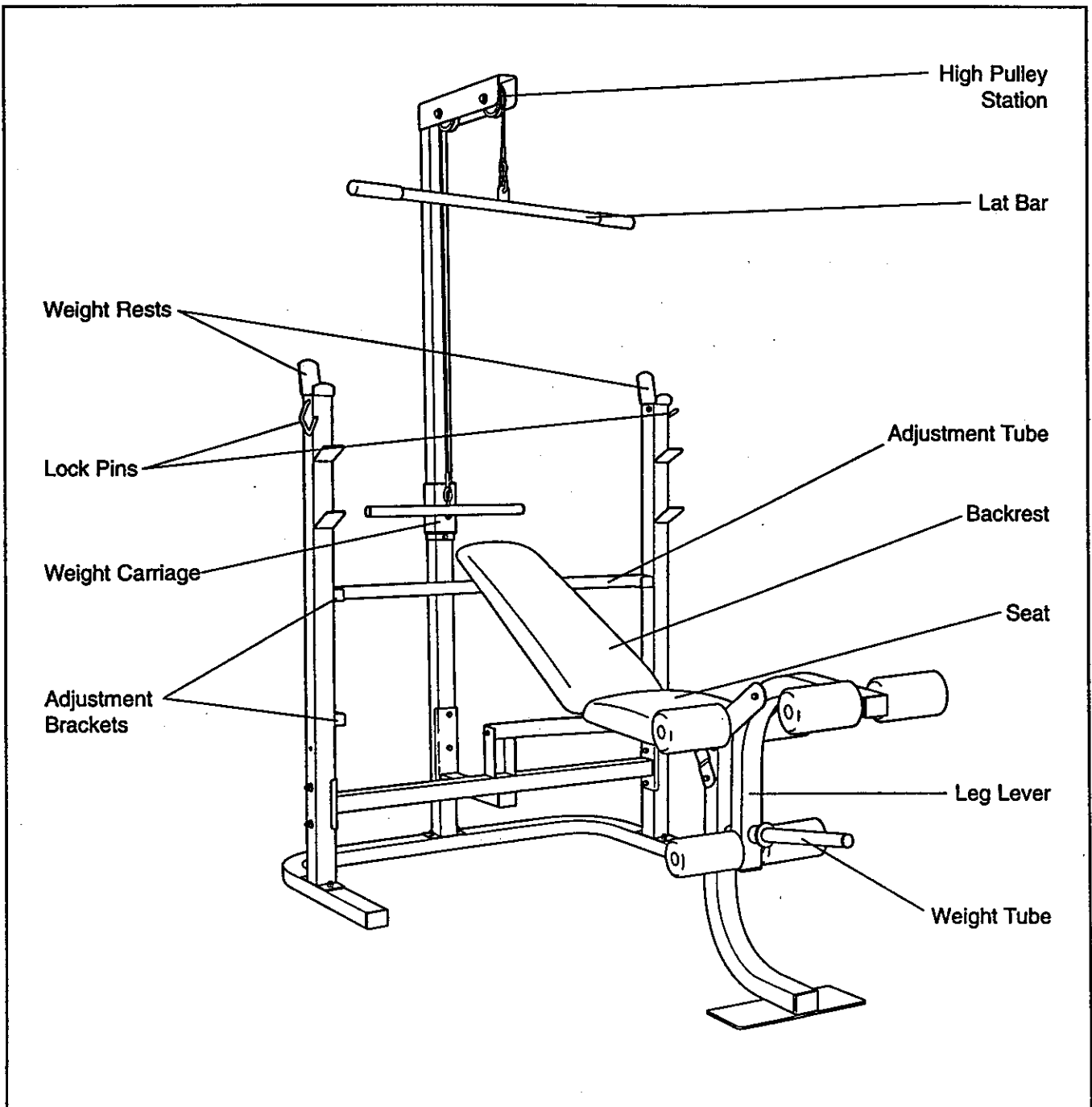

# PART IDENTIFICATION CHART

This chart is provided to help you identify the small parts used in assembly. The number in parenthesis below each part refers to the key number of the part. The second number refers to the quantity needed for assembly. **Important: Some parts may have been pre-assembled for shipping purposes. If you cannot find a part in the parts bags, check to see if it has been pre-assembled.**

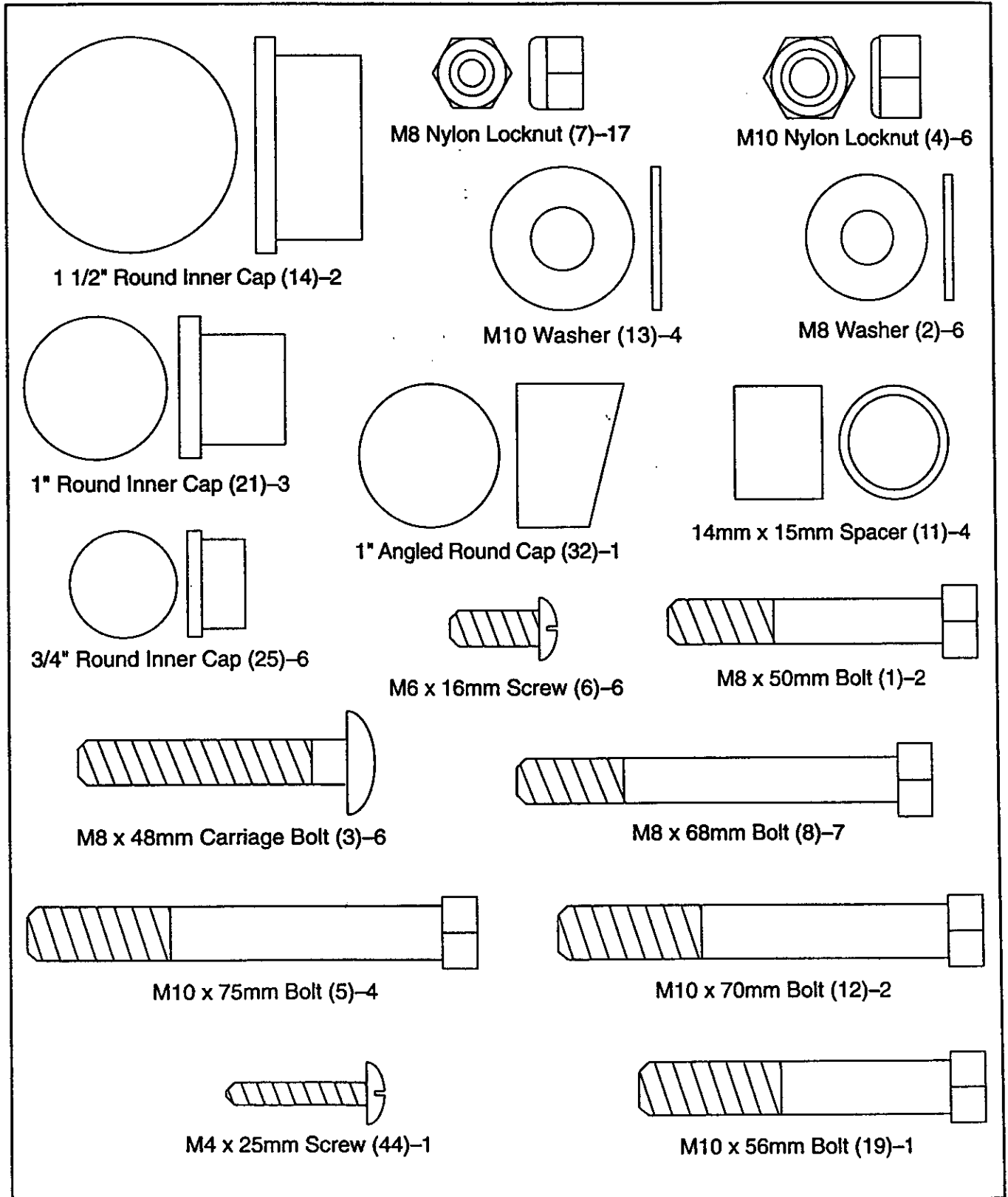



# ASSEMBLY

Before beginning assembly, carefully read the following information and instructions:

- Place all parts of the WEIDER® PRO 335 in a cleared area and remove the packing materials; do not dispose of the packing materials until assembly is completed.
- Read each assembly step before you begin.
- For help identifying the small parts used in assembly, use the **PART IDENTIFICATION CHART** on the previous page. Note: Some small parts may have been pre-attached for shipping purposes. If a part is not in the parts bag, check to see if it has been pre-attached.
- Tighten all parts as you assemble them, unless instructed to do otherwise.

- As you assemble the WEIDER® PRO 335, make sure that all parts are oriented as shown in the drawings.

**THE FOLLOWING TOOLS (NOT INCLUDED) ARE REQUIRED FOR ASSEMBLY:**

- Two (2) adjustable wrenches 
- One (1) standard screwdriver 
- One (1) rubber mallet 
- Lubricant, such as grease or petroleum jelly, and soapy water will also be needed.

Assembly will be more convenient if you have the following tools: A socket set, a set of open-end or closed-end wrenches, or a set of ratchet wrenches.

1. Before beginning assembly, be sure that you have read and understand the information in the box above.

Set the Base (40) on the floor. The indented holes must be facing the floor.

Press a 38mm x 50mm Inner Cap (16) into the Lower Lat Tower (23). Attach the Lower Lat Tower to the Base (40) with two M8 x 68mm Bolts (8), two M8 x 48mm Carriage Bolts (3), and four M8 Nylon Locknuts (7). Do not tighten the Nylon Locknuts yet.

2. Press two 38mm x 50mm Inner Caps (16) into the Base (40). Insert four M8 x 48mm Carriage Bolts (3) up through the Base.

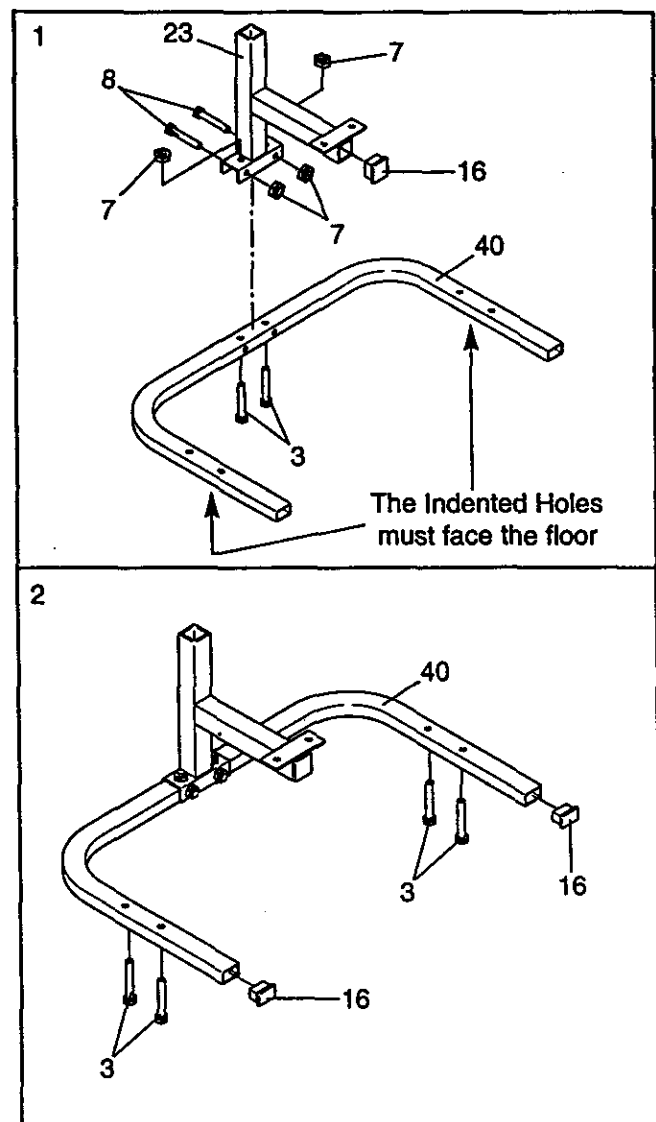

3. Press two 2 1/2" Square Bushings (22) into the Weight Carriage (15). Press two 1" Round Inner Caps (21) into the Weight Carriage.

Press a 2 1/2" Square Bushing (22) into the Carriage Stop (18). The slot in the Square Bushing must be aligned with the indicated hole in the Carriage Stop.

4. Slide the Weight Carriage (15) onto the Upper Lat Tower (41). The Weight Carriage must be oriented as shown.

Slide the Carriage Stop (18) onto the Upper Lat Tower (41). The 2 1/2" Square Bushing (22) must be facing toward the Weight Carriage (15). Attach the Carriage Stop to the Upper Lat Tower with an M8 x 68mm Bolt (8) and an M8 Nylon Locknut (7).

Insert the Upper Lat Tower (41) into the Lower Lat Tower (23). Fully tighten the M10 x 56mm Bolt (19) into the Lower Lat Tower.

Slide a Weight Stop (45) onto each side of the Weight Carriage (15).

5. Wrap the Cable (10) around a Pulley (9). Attach the Pulley to the Upper Lat Tower (41) with an M10 x 70mm Bolt (12), two M10 Washers (13), two 14mm x 15mm Spacers (11), and an M10 Nylon Locknut (4).

Attach the other Pulley (9) in the same manner.

Attach the other end of the Cable (10) to the eye-bolt on the Weight Carriage (15).

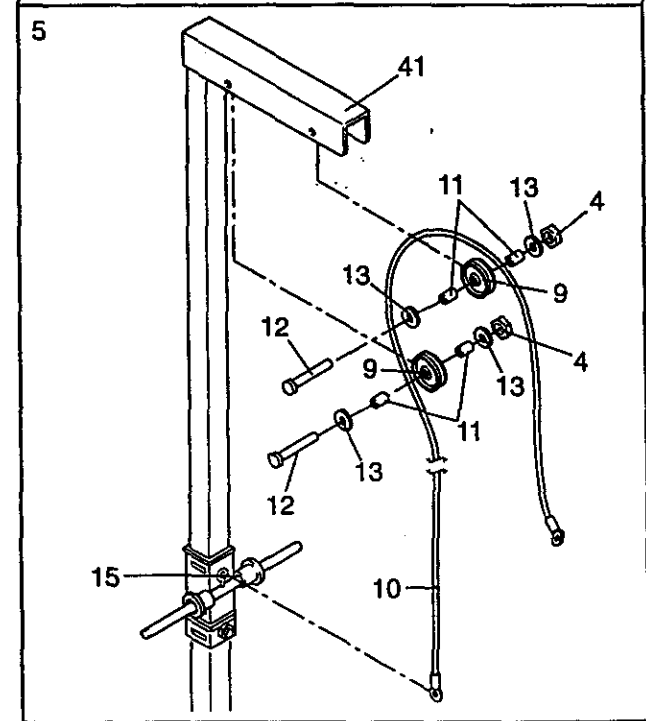
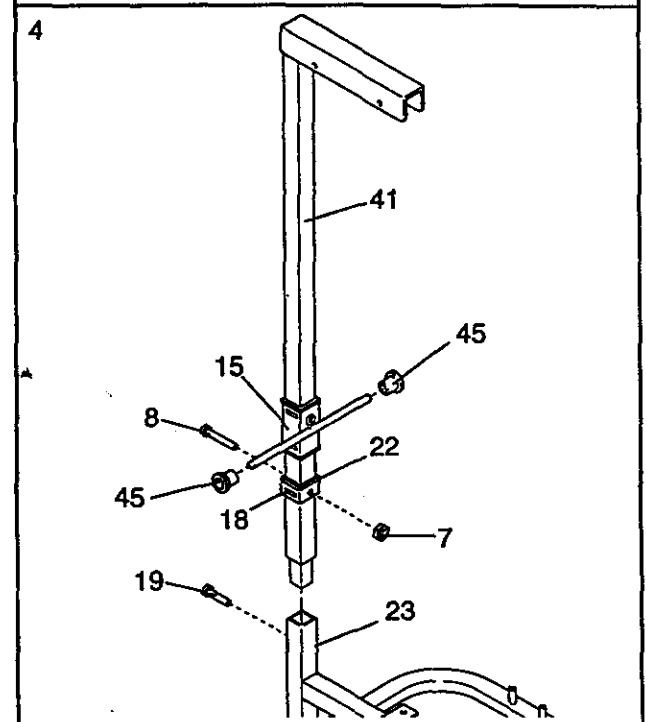
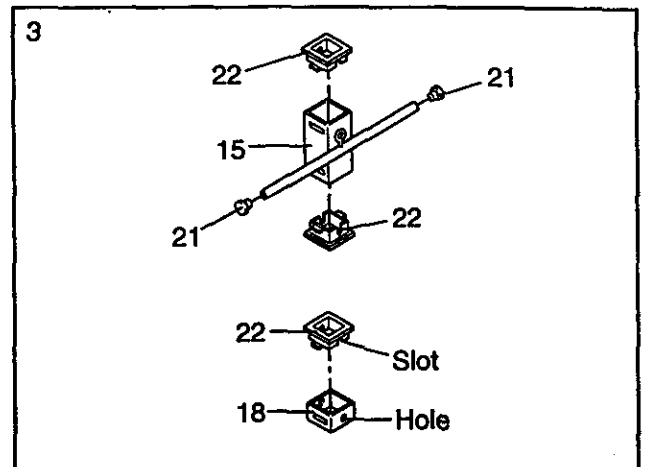

- Slide the Left Upright (42) onto the indicated M8 x 48mm Carriage Bolts (3). Hand-tighten an M8 Nylon Locknut (7) onto each Carriage Bolt. Be sure that the Upright is turned as shown. Do not tighten the Nylon Locknuts yet.

Attach the Right Upright (43) in the same manner.

Attach the Left Barbell Lock Pin (46) to the Left Upright (42) with an M8 Nylon Locknut (7). Attach the Right Barbell Lock Pin (17) to the Right Upright (43) in the same manner. The Barbell Lock Pins must be oriented as shown.

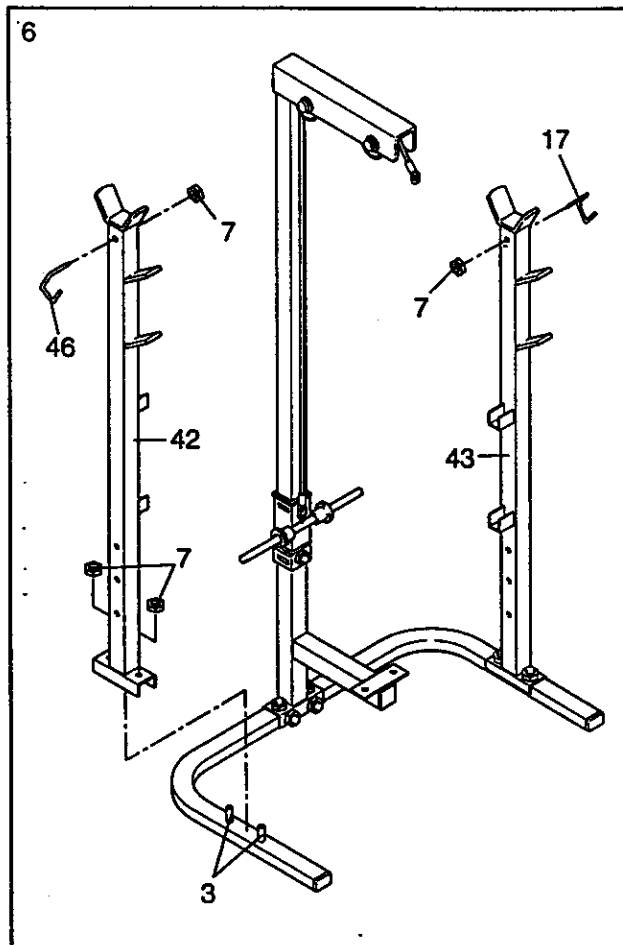

- Attach the Cross Brace (30) to the Lower Lat Tower (23) with two M8 x 50mm Bolts (1), two M8 Washers (2), and two M8 Nylon Locknuts (7).

Attach the Cross Brace (30) to the Left Upright (42) with two M8 x 68mm Bolts (8), two M8 Washers (2), and two M8 Nylon Locknuts (7).

Attach the Cross Brace (30) to the Right Upright (43) with two M8 x 68mm Bolts (8), two M8 Washers (2), and two M8 Nylon Locknuts (7).

Tighten all M8 Nylon Locknuts (7) used in steps 1, 6, and 7.

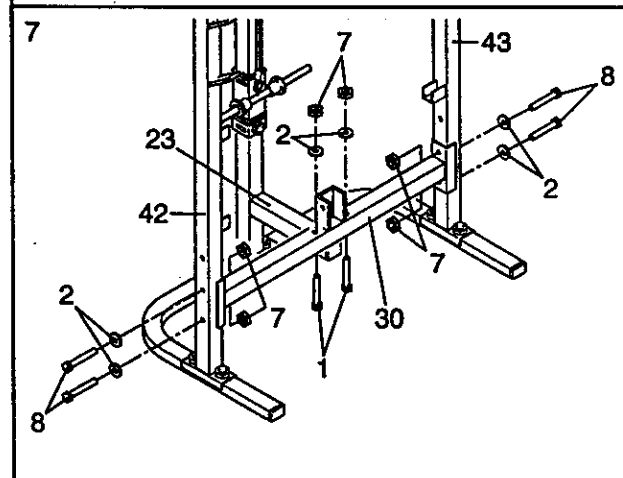

- Press a 1 1/2" Round Inner Cap (14) into each end of the Adjustment Tube (37).

Set the Adjustment Tube (37) into one set of adjustment brackets on the Left and Right Uprights (42, 43).

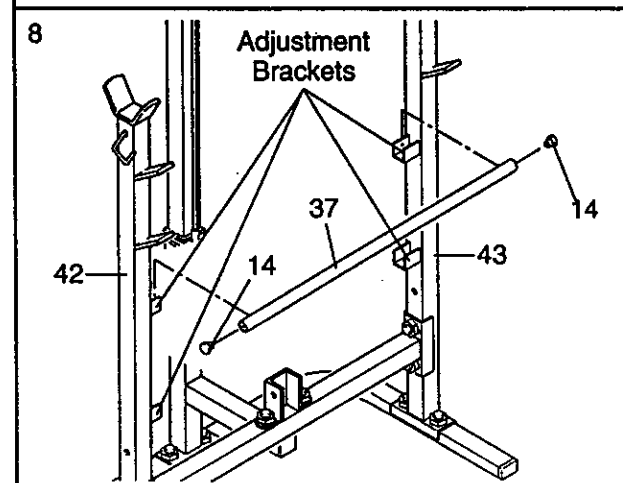



9. Lubricate an M10 x 75mm Bolt (5). Attach the Bench Frame (33) to the Cross Brace (30) with the M10 x 75mm Bolt and an M10 Nylon Locknut (4). **The Bench Frame must be turned as shown. Do not overtighten the Nylon Locknut.**

Attach the Bumper (24) to the Bench Frame (33) with an M4 x 25mm Screw (44).

Press a 38mm x 50mm Inner Cap (16) into the Bench Frame (33).

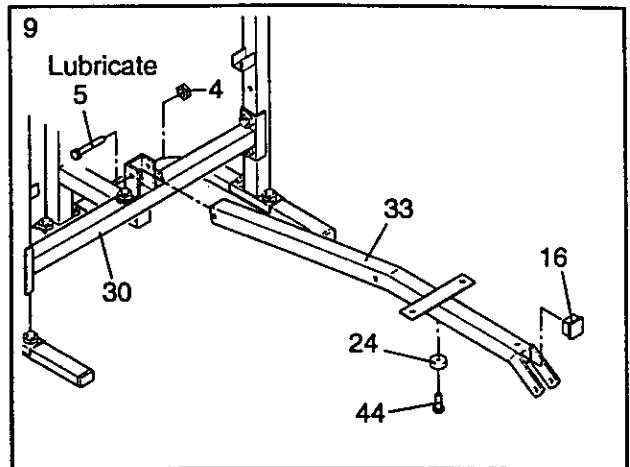

10. Press a 38mm x 50mm Inner Cap (16) into each end of the Front Leg (20).

Lubricate an M10 x 75mm Bolt (5). Attach the Front Leg (20) to the Bench Frame (33) with the M10 x 75mm Bolt (5) and an M10 Nylon Locknut (4). **Do not overtighten the Nylon Locknut.**

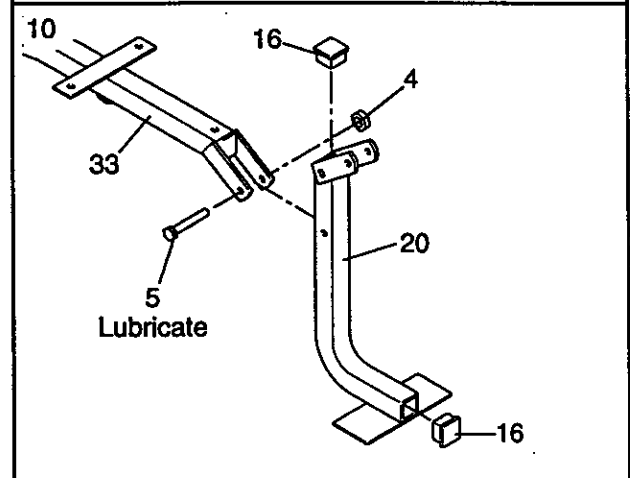

11. Press two 38mm x 50mm Inner Caps (16) into the Leg Lever (28). Press a 1" Round Inner Cap (21) into the Front Leg. Press an Angled Round Cap (32) onto the Leg Lever.

Lubricate an M10 x 75mm Bolt (5). Attach the Leg Lever (28) to the Front Leg (20) with the M10 x 75mm Bolt (5) and an M10 Nylon Locknut (4). **Do not overtighten the Nylon Locknut.**

Slide a Weight Stop (45) onto the Leg Lever (28).

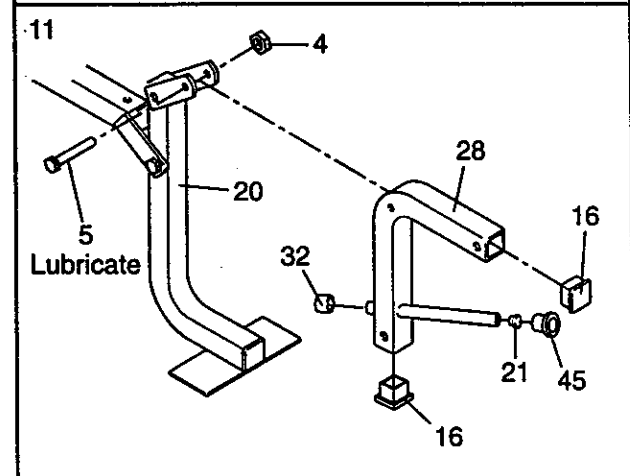

12. Attach both Backrest Brackets (38) to the Backrest (36) with four M6 x 16mm Screws (6). **The Backrests must be oriented as shown.**

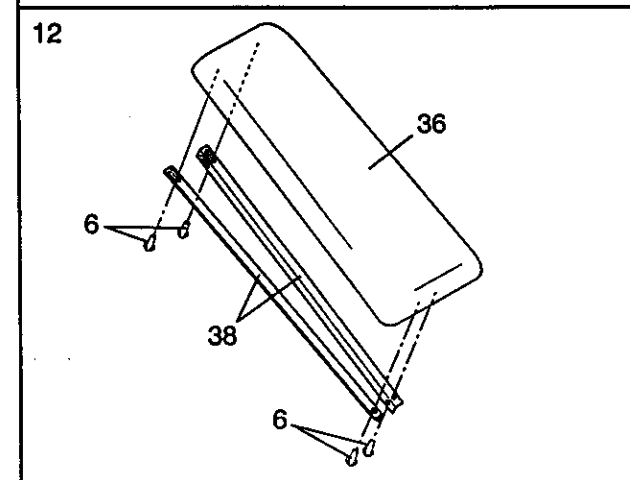

13. Lubricate an M10 x 75mm Bolt (5). Attach the Backrest Brackets (38) to the Bench Frame (33) with the M10 x 75mm Bolt and an M10 Nylon Locknut (4). Do not overtighten the Nylon Locknut.

Rest the Backrest Brackets (38) on the Adjustment Tube (37).

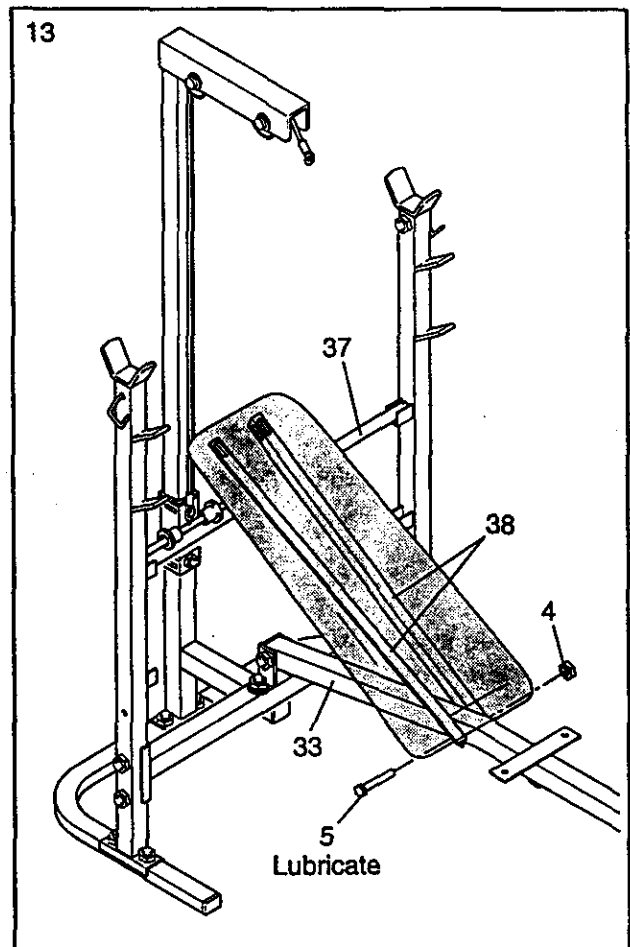

14. Attach the Seat (35) to the Bench Frame (33) with two M6 x 16mm Screws (6).

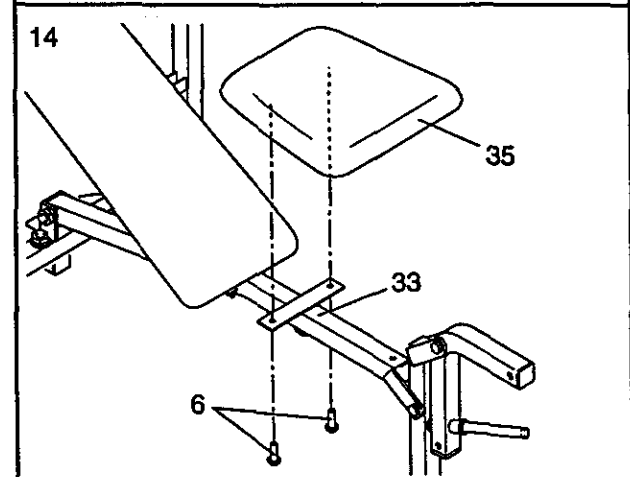

15. Press 3/4" Round Inner Caps (25) into the ends of all three Pad Tubes (27).

Insert a Pad Tube (27) through the indicated hole in the Leg Lever (28). Insert another Pad Tube through the other hole in the Leg Lever. Insert the remaining Pad Tube through the hole in the Front Leg (20).

Slide two Foam Pads (26) onto each Pad Tube (27).

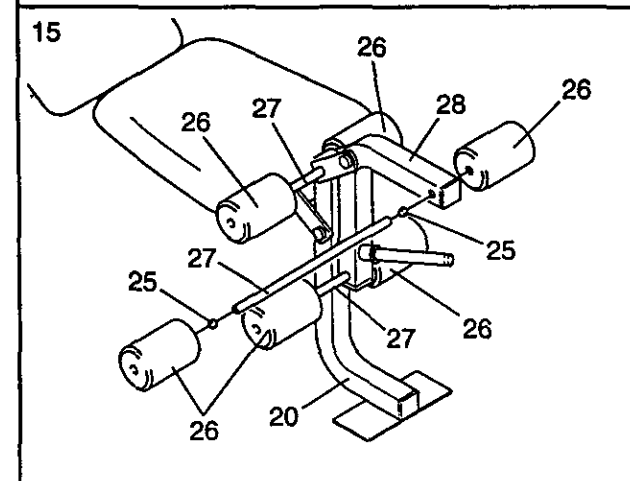

16. Wet the ends of the Lat Bar (31) with soapy water.  
Slide a Handgrip (39) onto each end of the Lat Bar.

**CAUTION:** Allow the Handgrips (39) to dry thoroughly before using the Lat Bar (31).

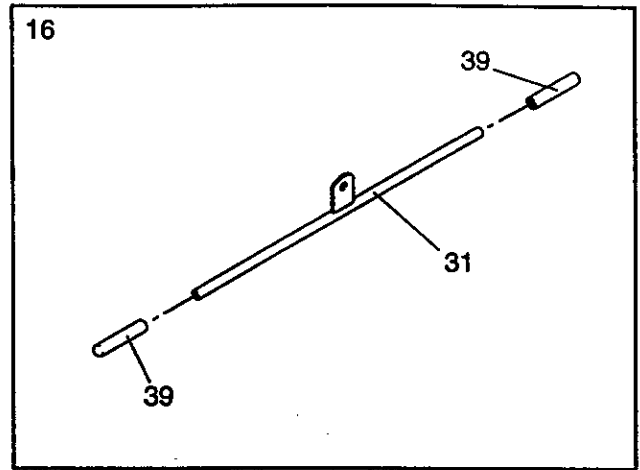

17. Be sure that all parts have been tightened properly. The use of all remaining parts will be explained in ADJUSTING THE WEIDER PRO 335 beginning on page 12 of this manual.

# ADJUSTING THE WEIDER PRO 335

The weight bench is designed to be used with your own weight set (not included). The steps below explain how the weight bench can be adjusted. See EXERCISE GUIDELINES on page 14 for important exercise information and refer to the accompanying exercise poster to see the correct form for each exercise. Refer also to the exercise information accompanying your weight set for additional exercises.

Inspect and tighten all parts each time you use the weight bench. Replace any worn parts immediately. The weight bench can be cleaned with a damp cloth and a mild, non-abrasive detergent. Do not use solvents.

## ATTACHING WEIGHTS TO THE WEIGHT CARRIAGE

To use the lat tower, first slide a Weight Stop (45) onto each side of the weight tube of the Weight Carriage (15). Slide the desired amount of weight (not included) onto the weight tube. Be sure that an equal amount of weight is on each side of the weight tube. Secure the weights on each side of the weight tube with a Spring Clip (29).

Do not place more than 150 pounds on the Weight Carriage. (Due to the fact that ab crunches are an aerobic exercise, we recommend that you do not place more than 50 pounds on the Weight Carriage (15) while performing ab crunch exercises.)

## ATTACHING WEIGHTS TO THE LEG LEVER

To use the Leg Lever (28), be sure there is a Weight Stop (45) on the weight tube. Then slide the desired amount of weight (not included) onto the weight tube.

Do not place more than 150 pounds on the Leg Lever.

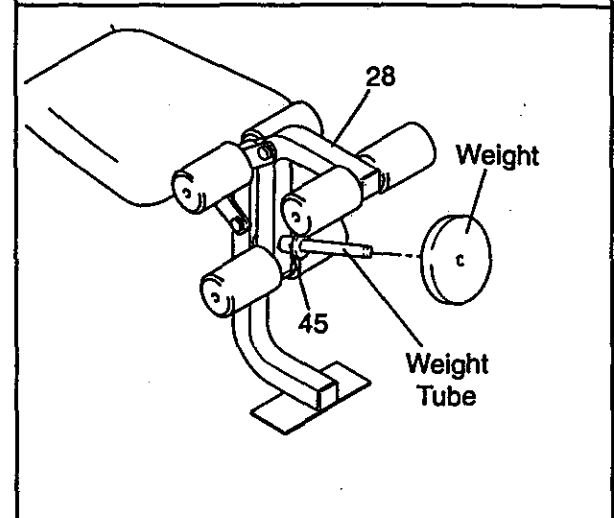
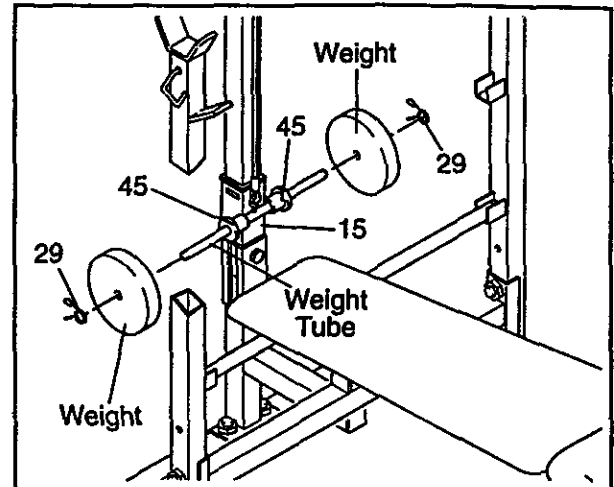

## ADJUSTING THE BACKREST

The Backrest (36) can be set at three different positions: the level position, the decline position, and the incline position.

To change the position of the Backrest (36) to either the incline position or the level position, move the Adjustment Tube (37) to a different set of adjustment brackets on the Left and Right Uprights (42, 43). Set the Backrest (36) onto the Adjustment Tube.

To change the position of the Backrest (36) to the decline position, remove the Adjustment Tube (37). Set the Backrest (36) onto the Bench Frame (33).

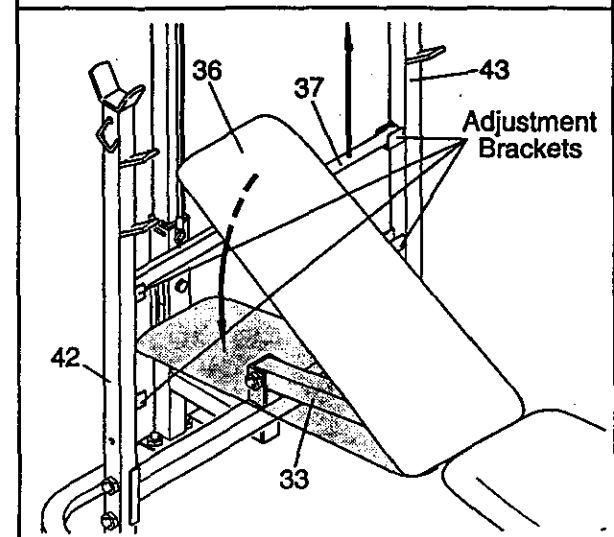

## ATTACHING THE LAT BAR TO THE HIGH PULLEY STATION

Attach the Lat Bar (31) to the Cable (10) with a Cable Clip (34).

**WARNING:** Always sit on the backrest when using the high pulley station. The backrest must be in the level position (see ADJUSTING THE BACKREST on page 12).

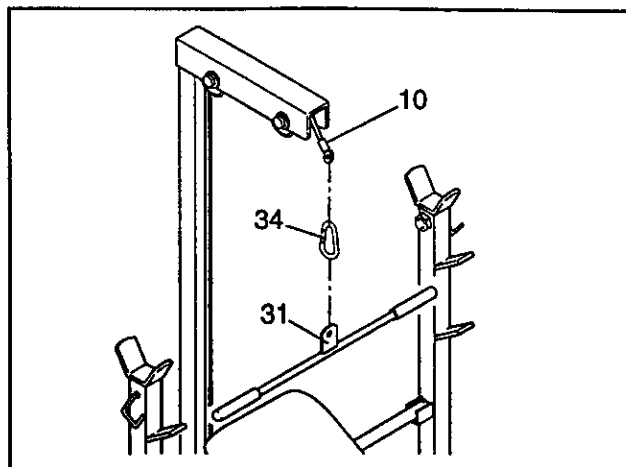

## LOCKING THE BARBELL

To change weights while your barbell (not included) is on the Uprights (42, 43), secure your barbell with the Barbell Lock Pins (17, 46). This will reduce the possibility of the barbell tipping while you change weights. Place the same amount of weight on both ends of the barbell.

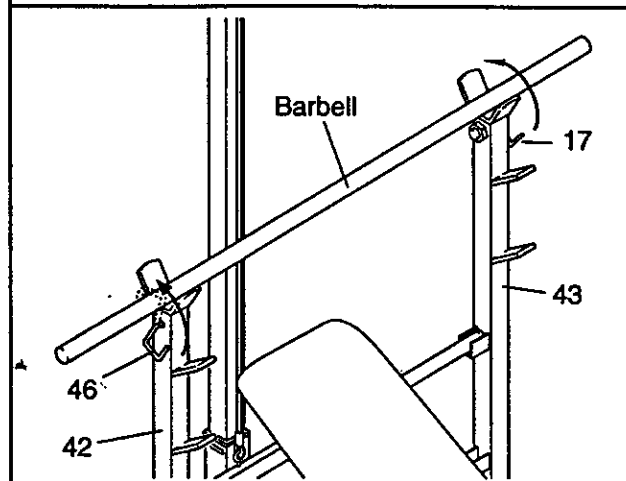

## STORING THE WEIGHT BENCH

The WEIDER PRO 335 weight bench is designed to be folded into a compact storage position when it is not in use.

First remove the Adjustment Tube (37). Lay the Backrest (36) on the Bench Frame (33).

Fold the Bench Frame (33) up, as shown in the inset drawing. Fold down the Front Leg (20). Set the Adjustment Tube (37) into the upper adjustment brackets to hold the Bench Frame in place.

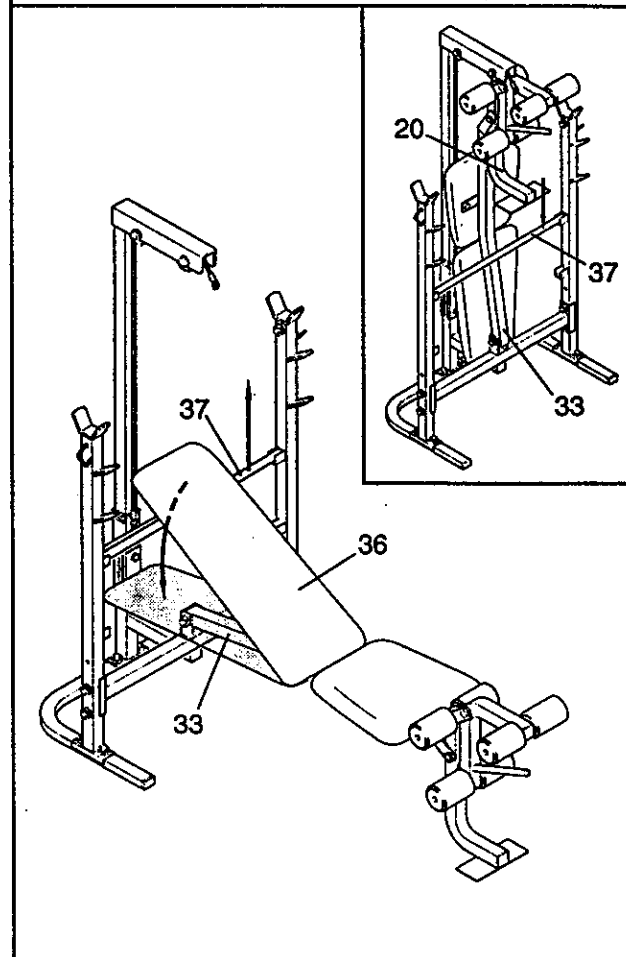

---

# EXERCISE GUIDELINES

## THE FOUR BASIC TYPES OF WORKOUTS

### • Muscle Building

In order to increase the size and strength of your muscles, you must push your muscles to a high percentage of their capacity. You must also progressively increase the intensity of your exercise so that your muscles will continually adapt and grow. Each individual exercise can be tailored to the proper intensity level by changing the amount of weight used, or the number of repetitions or sets performed. (A "repetition" is one complete cycle of an exercise, such as one sit-up. A "set" is a series of repetitions performed consecutively.)

The proper amount of weight for each exercise depends upon the individual user. It is up to you to gauge your limits. Select the amount of weight that you think is right for you. Begin with 3 sets of 8 repetitions for each exercise that you perform. Rest for 3 minutes after each set. When you can complete 3 sets of 12 repetitions without difficulty, increase the amount of weight.

### • Toning

To tone your muscles, you must push your muscles to a moderate percentage of their capacity. Select a moderate amount of weight and increase the number of repetitions in each set. Complete as many sets of 15 to 20 repetitions as possible without discomfort. Rest for 1 minute after each set. Work your muscles by completing more sets rather than by using high amounts of weight.

### • Weight Loss

To lose weight, use a low amount of weight and increase the number of repetitions in each set. Exercise for 20 to 30 minutes, resting for a maximum of 30 seconds between sets.

### • Cross Training

In the pursuit of a complete and well-balanced fitness program, many have found that cross training is the answer. We recommend that on Monday, Wednesday and Friday, you plan weight training workouts. On Tuesday and Thursday, plan 20 to 30 minutes of aerobic exercise, such as cycling, running or swimming. Rest from both weight training and aerobic exercise for at least one full day each week to give your body time to regenerate. By combining weight training with aerobic exercise, you can reshape and strengthen your body, plus develop a stronger heart and lungs.

## PERSONALIZING YOUR EXERCISE PROGRAM

We have not specified an exact length of time for each workout, or a specific number of repetitions or sets for each exercise. It is very important to avoid overdoing it during the first few months of your exercise program, and to progress at your own pace. If you experience pain or dizziness at any time while exercising, stop immediately and begin to cool down. Find out what is wrong before continuing. Remember that adequate rest and a proper diet are also important.

### WARMING UP

Begin each workout with 5 to 10 minutes of light stretching and exercise to warm up. Warming up prepares your body for exercise by increasing circulation, raising your body temperature and delivering more oxygen to your muscles.

### WORKING OUT

Each workout should include 6 to 10 different exercises. Select exercises for every major muscle group, with emphasis on the areas that you want to develop the most. To give balance and variety to your workouts, vary the exercises from workout to workout.

Schedule your workouts for the time of day when your energy level is the highest. Each workout should be followed by at least one day of rest. Once you find the schedule that is right for you, stick with it.

### EXERCISE FORM

In order to obtain the greatest benefits from exercising, it is essential to maintain proper form.

Maintaining proper form means moving through the full range of motion for each exercise, and moving only the appropriate parts of the body. Exercising in an uncontrolled manner will leave you feeling exhausted. On the exercise poster accompanying this manual, you will find photographs showing the correct form for several exercises. A description of each exercise is also provided, along with a list of the muscles affected. Refer to the muscle chart on page 16 to find the locations of the muscles.

The repetitions in each set should be performed smoothly and without pausing. The exertion stage of each repetition should last about half as long as the return stage. Proper breathing is important. Exhale during the exertion stage of each repetition and inhale during the return stroke; never hold your breath. Rest for 3 minutes after each set if you are doing a muscle building workout, 1 minute after each set if you are

doing a toning workout, and 30 seconds after each set if you are doing a weight loss workout. Plan to spend the first couple of weeks familiarizing yourself with the equipment and learning the proper form for each exercise.

### **COOLING DOWN**

End each workout with 5 to 10 minutes of stretching. Include stretches for both your arms and legs. Move slowly as you stretch—do not bounce. Ease into each stretch gradually and go only as far as you can without strain. Stretching at the end of each workout is very effective for increasing flexibility.

### **STAYING MOTIVATED**

For motivation, keep a record of each workout. The chart on page 17 of this manual can be photocopied and used to schedule and record your workouts. List the date, exercises performed, weight, and numbers of sets and repetitions completed. Record your weight and key body measurements at the end of every month.

Remember, the key to achieving the greatest results is to make exercise a regular and enjoyable part of your everyday life.

**MUSCLE CHART**

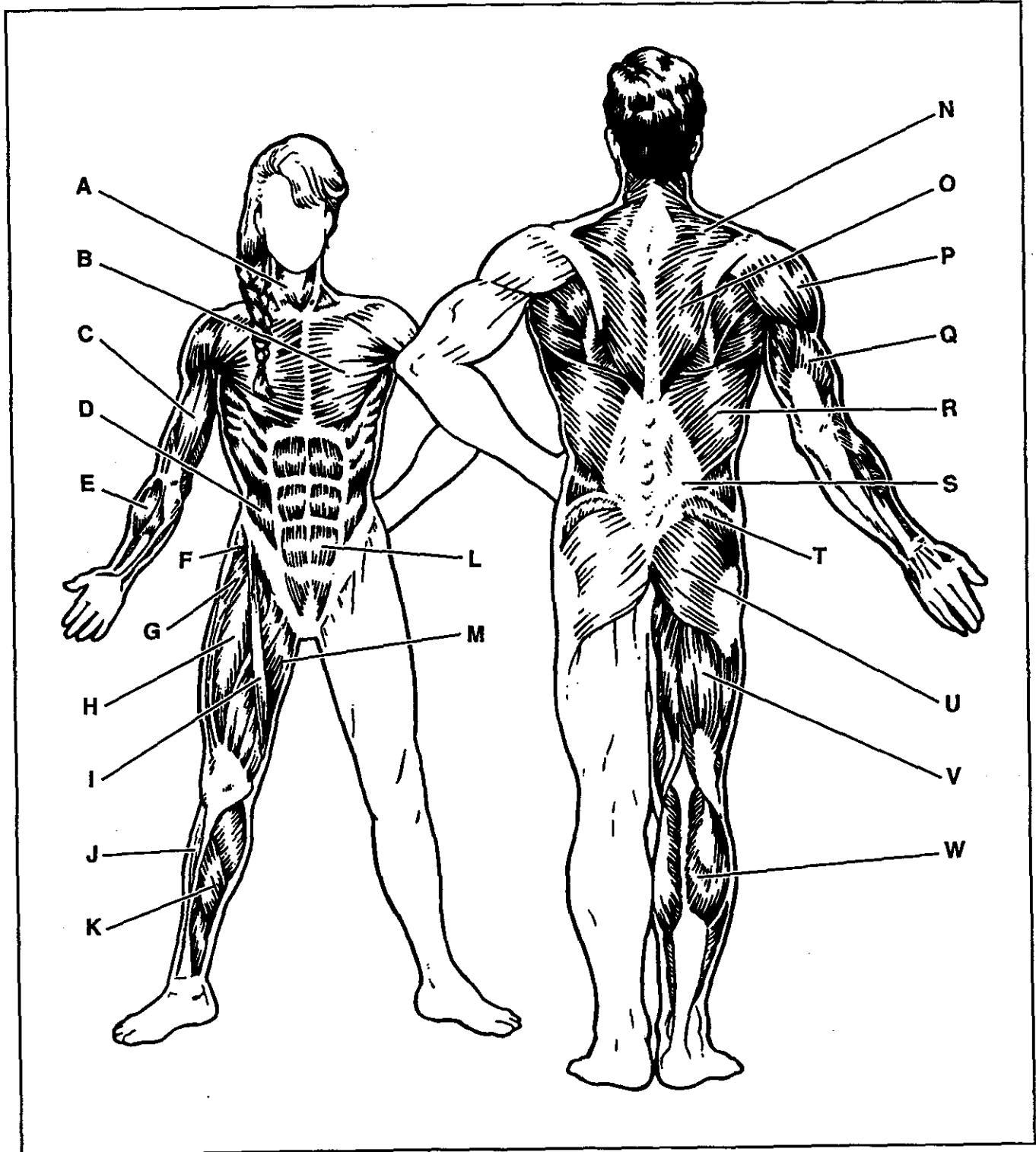

- A. Sternomastoid (neck)
- B. Pectoralis Major (chest)
- C. Biceps (front of arm)
- D. Obliques (waist)
- E. Brachioradialis (forearm)
- F. Hip Flexors (upper thigh)
- G. Abductor (outer thigh)
- H. Quadriceps (front of thigh)

- I. Sartorius (front of thigh)
- J. Tibialis Anterior (front of calf)
- K. Soleus (front of calf)
- L. Rectus Abdominus (stomach)
- M. Adductor (inner thigh)
- N. Trapezius (upper back)
- O. Rhomboideus (upper back)
- P. Deltoid (shoulder)

- Q. Triceps (back of arm)
- R. Latissimus Dorsi (mid back)
- S. Spinae Erectors (lower back)
- T. Gluteus Medius (hip)
- U. Gluteus Maximus (buttocks)
- V. Hamstring (back of leg)
- W. Gastrocnemius (back of calf)



<b>MONDAY</b> Date:    /    /	<b>EXERCISE</b>	<b>WEIGHT</b>	<b>SETS</b>	<b>REPS</b>

**TUESDAY    AEROBIC EXERCISE**  
 Date:    /    /

<b>WEDNESDAY</b> Date:    /    /	<b>EXERCISE</b>	<b>WEIGHT</b>	<b>SETS</b>	<b>REPS</b>

**THURSDAY    AEROBIC EXERCISE**  
 Date:    /    /

<b>FRIDAY</b> Date:    /    /	<b>EXERCISE</b>	<b>WEIGHT</b>	<b>SETS</b>	<b>REPS</b>

Make photocopies of this page for scheduling and recording your workouts.

# PART LIST—Model No. 831.150380

R0896A

Key No.	Qty.	Part No.	Description	Key No.	Qty.	Part No.	Description
1	2	013105	M8 x 50mm Bolt	25	6	112402	3/4" Round Inner Cap
2	6	014012	M8 Washer	26	6	103805	Foam Pad
3	6	013001	M8 x 48mm Carriage Bolt	27	3	132148	Pad Tube
4	6	012033	M10 Nylon Locknut	28	1	132149	Leg Lever
5	4	132138	M10 x 75mm Bolt	29	2	130312	Spring Clip
6	6	132137	M6 x 16mm Screw	30	1	132187	Cross Brace
7	17	012002	M8 Nylon Locknut	31	1	132150	Lat Bar
8	7	013047	M8 x 68mm Bolt	32	1	123396	1" Angled Round Cap
9	2	115370	Pulley	33	1	132151	Bench Frame
10	1	132140	Cable	34	1	103807	Cable Clip
11	4	128051	14mm x 15mm Spacer	35	1	132188	Seat
12	2	110942	M10 x 70mm Bolt	36	1	132189	Backrest
13	4	014015	M10 Washer	37	1	132152	Adjustment Tube
14	2	115998	1 1/2" Round Inner Cap	38	2	132182	Backrest Bracket
15	1	132143	Weight Carriage	39	2	112560	Handgrip
16	8	132142	38mm x 50mm Inner Cap	40	1	132183	Base
17	1	132144	Right Barbell Lock Pin	41	1	132184	Upper Lat Tower
18	1	132145	Carriage Stop	42	1	132185	Left Upright
19	1	111083	M10 x 56mm Bolt	43	1	132186	Right Upright
20	1	132146	Front Leg	44	1	132139	M4 x 25mm Screw
21	3	120733	1" Round Inner Cap	45	3	132403	Weight Stop
22	3	127941	2 1/2" Square Bushing	46	1	133123	Left Barbell Lock Pin
23	1	132147	Lower Lat Tower	#	1	132002	User's Manual
24	1	122950	Bumper	#	1	129186	Exercise Poster

Note: "#" indicates a non-illustrated part. Specifications are subject to change without notice. See the back cover of this manual for information about ordering replacement parts.

# EXPLODED DRAWING—Model No. 831.150380

R0896A

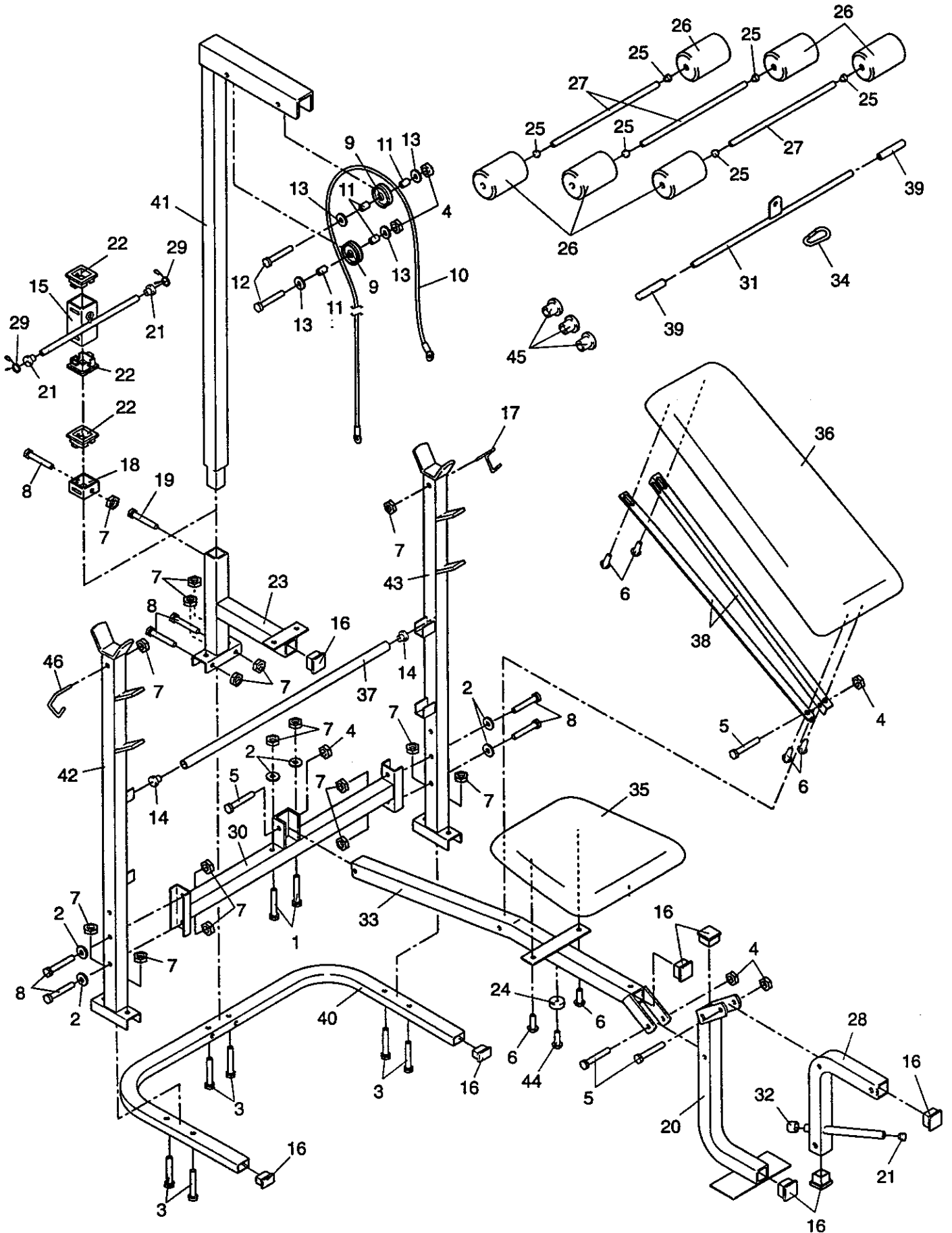

# SEARS

Model No. 831.150380

## QUESTIONS?

If you find that:

- you need help assembling or operating the WEIDER® PRO 335
- a part is missing
- or you need to schedule repair service

call our toll-free HELPLINE

**1-800-736-6879**

Monday–Saturday, 7 am–7 pm  
Central Time (excluding holidays)

## REPLACEMENT PARTS

If parts become worn and need to be replaced, call the following toll-free number

**1-800-FON-PART**  
**(1-800-366-7278)**

The model number and serial number of your WEIDER® PRO 335 are listed on a decal attached to the frame. See the front cover of this manual to find the location of the decal.

All replacement parts are available for immediate purchase or special order when you visit your nearest SEARS Service Center. To request service or to order parts by telephone, call the toll-free numbers listed at the left.

When requesting help or service, or ordering parts, please be prepared to provide the following information:

- The MODEL NUMBER of the product (831.150380).
- The NAME of the product (WEIDER® PRO 335 Weight Bench).
- The PART NUMBER of the PART (see the PART LIST and the EXPLODED DRAWING on pages 18 and 19 of this manual).
- The DESCRIPTION of the PART (see the PART LIST and the EXPLODED DRAWING on pages 18 and 19 of this manual).

SEARS, ROEBUCK AND CO., HOFFMAN ESTATES, IL 60179