

PRO

635

PATENT PENDING

USER'S MANUAL

WEIDER

Model No. 831.150390

Serial No. _____

The serial number can be found in the location shown below. Write the serial number in the space above.

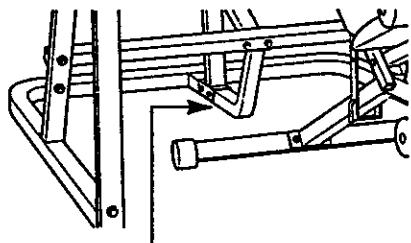

Serial Number Decal

EXERCISE
EQUIPMENT

QUESTIONS

HELPLINE!

1-800-736-6879

CAUTION

Read all precautions and instructions in this manual before using this equipment. Save this manual for future reference.

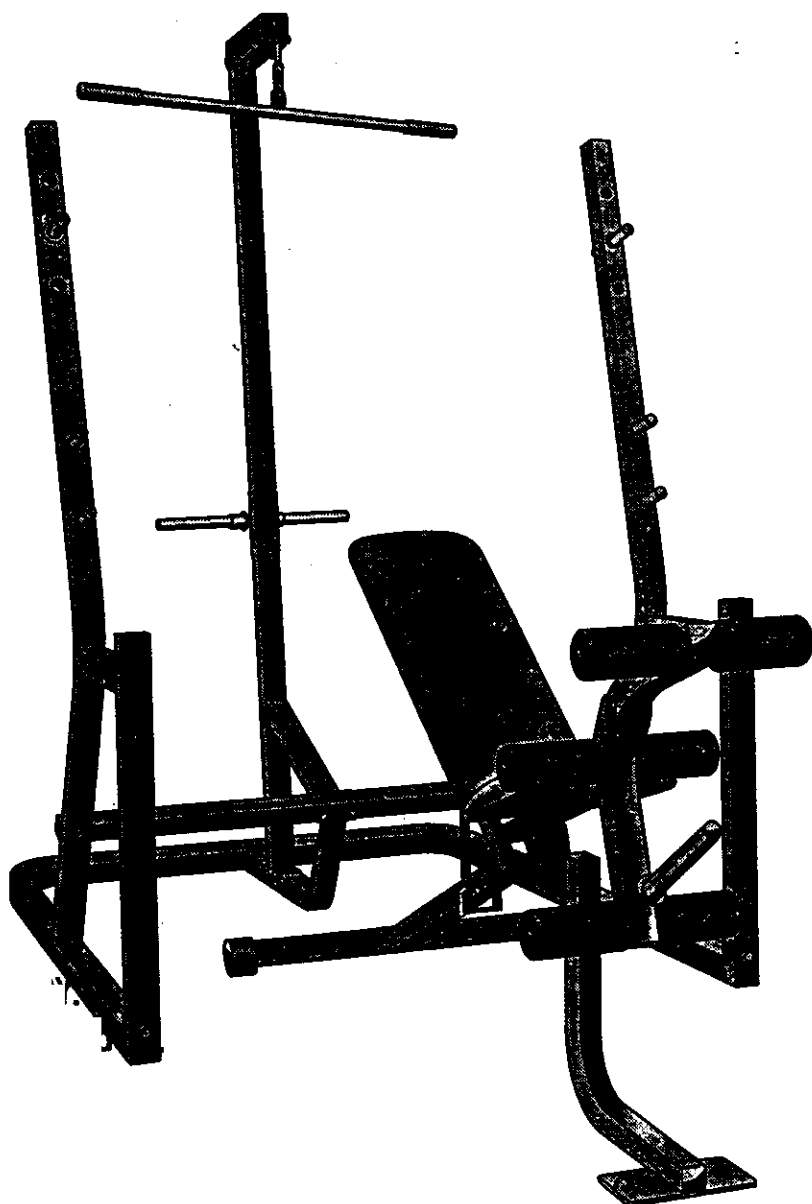

SEARS

SEARS, ROEBUCK AND CO., HOFFMAN ESTATES, IL 60179

TABLE OF CONTENTS

FULL 90 DAY WARRANTY	2
IMPORTANT PRECAUTIONS	3
BEFORE YOU BEGIN	4
ASSEMBLY	5
ADJUSTING THE WEIDER PRO 635	12
EXERCISE GUIDELINES	14
PART LIST	18
EXPLODED DRAWING	19
ORDERING REPLACEMENT PARTS	Back Cover

Note: A PART IDENTIFICATION CHART is attached to the center of this manual. Remove the PART IDENTIFICATION CHART before beginning assembly.

FULL 90 DAY WARRANTY

For 90 days from the date of purchase, if failure occurs due to defect in material or workmanship in this SEARS WEIGHT BENCH EXERCISER, contact the nearest SEARS Service Center throughout the United States and SEARS will repair or replace the WEIGHT BENCH EXERCISER, free of charge.

This warranty does not apply when the WEIGHT BENCH EXERCISER is used commercially or for rental purposes.

This warranty gives you specific legal rights, and you may also have other rights which vary from state to state.

SEARS, ROEBUCK AND CO., DEPT. 817WA, HOFFMAN ESTATES, IL 60179

IMPORTANT PRECAUTIONS

WARNING: To reduce the risk of serious injury, read the following important precautions before using the weight bench.

1. Read all instructions in this manual before using the weight bench.
2. Use the weight bench only as described in this manual.
3. Use the weight bench only on a level surface. Cover the floor beneath the weight bench for protection.
4. Inspect and tighten all parts each time you use the weight bench. Replace any worn parts immediately.
5. Keep small children and pets away from the weight bench at all times.
6. Always be sure there is an equal amount of weight on each side of your barbell (not included) when you are using it.
7. When you are using the weight carriage, be sure there is an equal amount of weight on each side of the weight tube.
8. Always wear athletic shoes for foot protection while exercising.
9. Keep hands and feet away from moving parts.
10. The weight bench does not include weights. The weight bench is designed to support a maximum of 510 pounds, including the user, a weight bar and weights. Do not place more than 310 pounds, including a weight bar and weights, on the weight rests. Do not place more than 150 pounds on the weight carriage; use no more than 50 pounds for ab crunches. Do not place more than 150 pounds on the leg lever.
11. When using the backrest, make sure that the "L" pin is fully inserted through the adjustment bracket and the bench frame.
12. If you feel pain or dizziness at any time while exercising, stop immediately and begin cooling down.
13. It is the responsibility of the owner to ensure that all users of the weight bench are adequately informed of all precautions.

WARNING: Before beginning this or any exercise program, consult your physician. This is especially important for persons over the age of 35 or persons with pre-existing health problems. Read all instructions before using. SEARS assumes no responsibility for personal injury or property damage sustained by or through the use of this product.

BEFORE YOU BEGIN

Thank you for selecting the WEIDER® PRO 635 Weight Bench. The versatile PRO 635 Weight Bench is designed to be used with your own weight set (not included) to develop every major muscle group of the body. Whether your goal is a shapely figure, dramatic muscle size and strength, or a healthier cardiovascular system, the PRO 635 Weight Bench will help you to achieve the specific results you want.

For your benefit, read this manual carefully before using the WEIDER® PRO 635 Weight Bench. If you have additional questions, please call our toll-free

HELPLINE at 1-800-736-6879, Monday through Saturday, 7 a.m. until 7 p.m. Central Time (excluding holidays). To help us assist you, please note the product model number and serial number before calling. The model number is 831.150390. The serial number can be found on a decal attached to the PRO 635 Weight Bench (see the front cover of this manual).

Before reading further, please review the drawing below and familiarize yourself with the parts that are labeled.

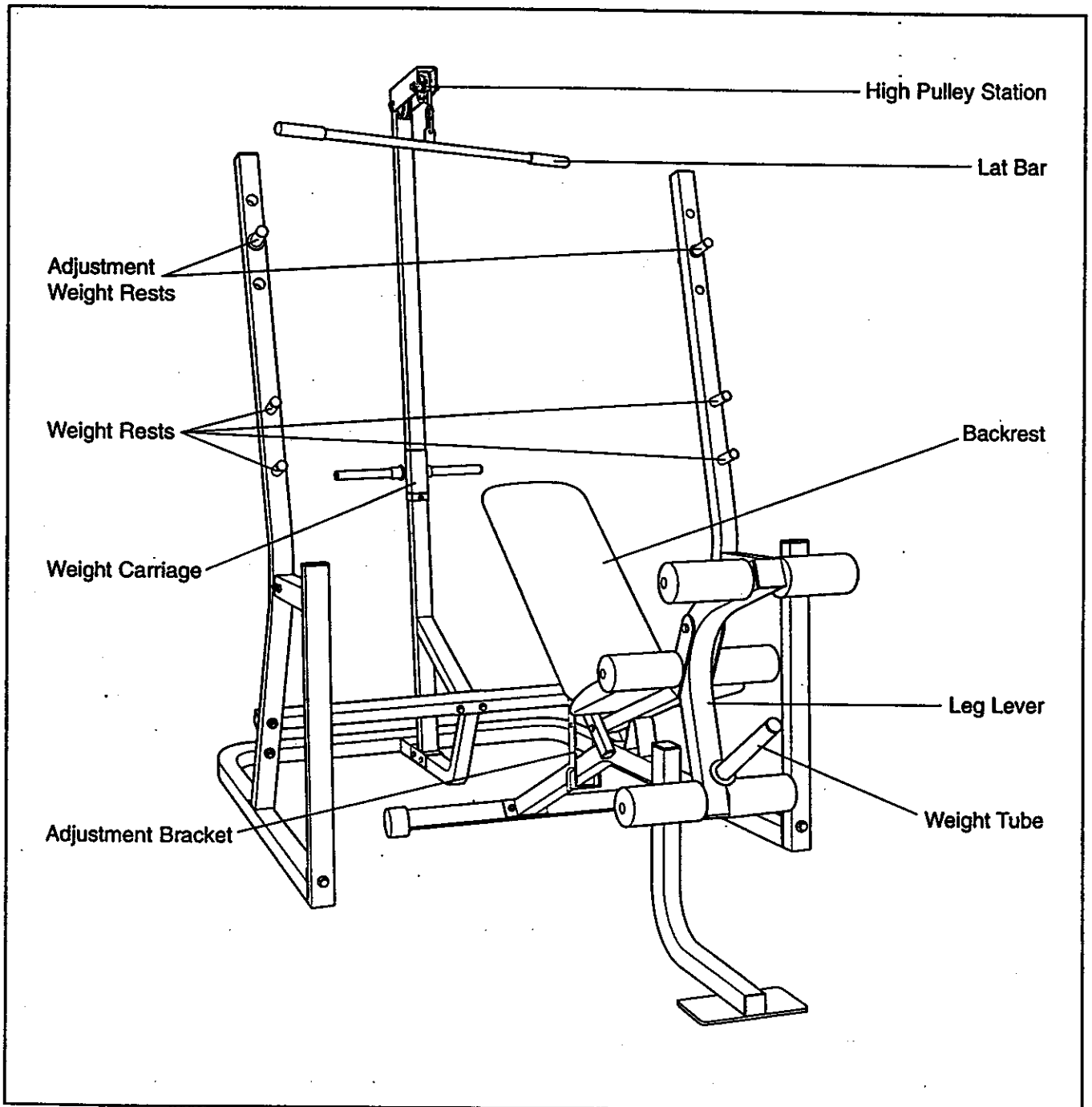



ASSEMBLY

Before beginning assembly, carefully read the following information and instructions:

- Place all parts in a cleared area and remove the packing materials; do not dispose of the packing materials until assembly is completed.
- Read each assembly step before you begin.
- For help identifying the small parts used in assembly, use the **PART IDENTIFICATION CHART** at the center of this manual. Note: Some small parts may have been pre-attached for shipping purposes. If a part is not in the parts bag, check to see if it has been pre-attached.
- Tighten all parts as you assemble them, unless instructed to do otherwise.

- During assembly, make sure that all parts are oriented as shown in the drawings.

THE FOLLOWING TOOLS (NOT INCLUDED) ARE REQUIRED FOR ASSEMBLY:

- Two (2) adjustable wrenches 
- One (1) standard screwdriver 
- One (1) rubber mallet 
- Lubricant, such as grease or petroleum jelly, and soapy water will also be needed.

Assembly will be more convenient if you have the following tools: A socket set, a set of open-end or closed-end wrenches, or a set of ratchet wrenches.

1. Before beginning assembly, be sure that you have read and understand the information in the box above.

Attach the Left Base (53), the Right Base (40), and the Lat Base (48) with two M8 x 60mm Carriage Bolts (3), two M8 x 68mm Bolts (1), and four M8 Nylon Locknuts (11). Do not tighten the Nylon Locknuts yet.

2. Press a 50mm Square Inner Cap (21) into each Weight Upright (42). Press four 25mm Round Inner Caps (23) into each Weight Upright.

Attach a Weight Upright (42) to the Left Base (53) with an M8 x 60mm Carriage Bolt (3) and an M8 Nylon Locknut (11). Do not tighten the Nylon Locknut yet.

Attach the other Weight Upright (42) to the Right Base (40) with an M8 x 60mm Carriage Bolt (3) and an M8 Nylon Locknut (11). Do not tighten the Nylon Locknut yet.

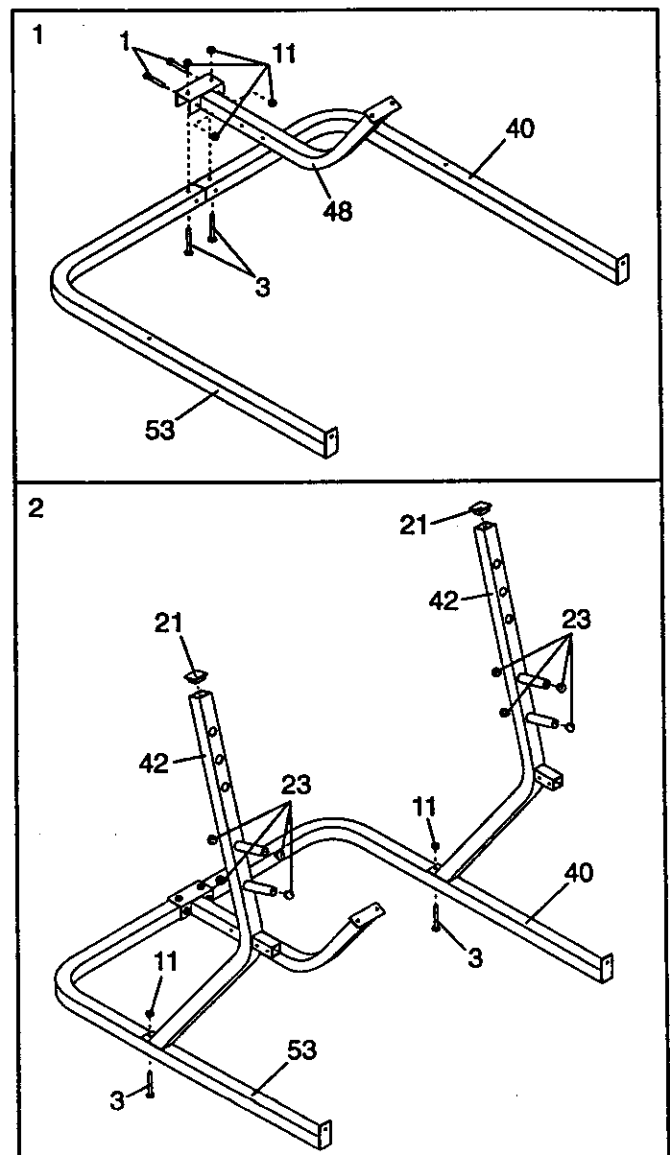

3. Press a 50mm Square Inner Cap (21) into each Front Upright (43).

Attach a Front Upright (43) to a Weight Upright (42) with two M8 x 68mm Bolts (1), four M8 Washers (15), and two M8 Nylon Locknuts (11). Do not tighten the Nylon Locknuts yet.

Attach the other Front Upright (43) to the other Weight Upright (42) in the same manner.

Attach the Front Upright (43) to the Left Base (53) with an M8 x 68mm Bolt (1), an M8 Washer (15), and an M8 Nylon Locknut (11). Do not tighten the Nylon Locknut yet.

Attach the other Front Upright (43) to the Right Base (40) in the same manner.

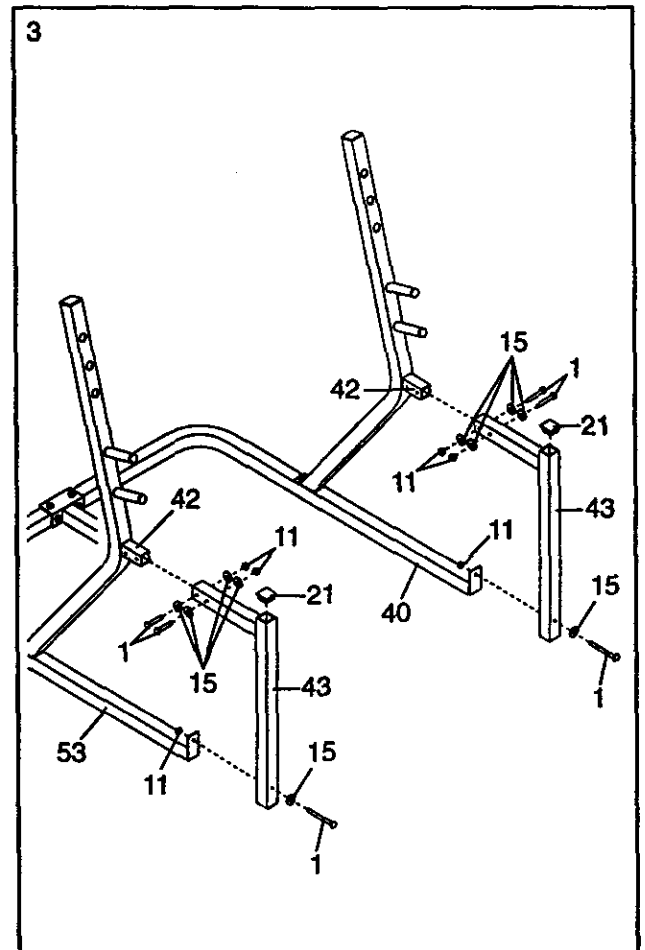

4. Press a 50mm Square Inner Cap (21) into each end of the Crossbrace (47).

Attach the Crossbrace (47) to the Lat Base (48) with two M8 x 68mm Bolts (1), two M8 Washers (15), and two M8 Nylon Locknuts (11). Do not tighten the Nylon Locknuts yet.

Attach the Crossbrace (47) to both Weight Uprights (42) with four M8 x 68mm Bolts (1), four M8 Washers (15), and four M8 Nylon Locknuts (11). Do not tighten the Nylon Locknuts yet.

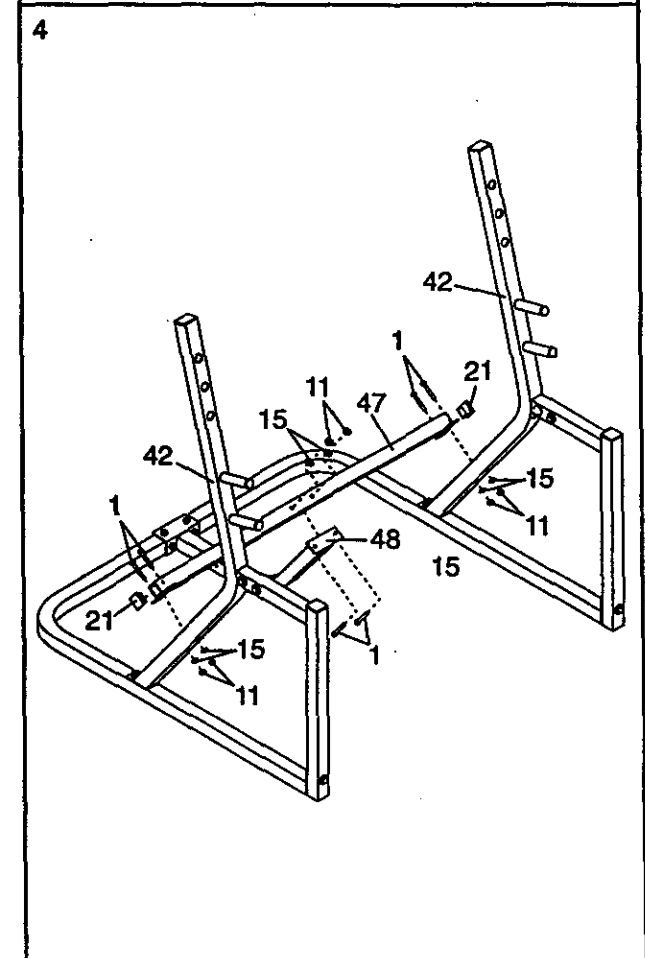

- Attach the Lower Lat Tower (46) to the Lat Base (48) with two M8 x 68mm Bolts (1) and two M8 Nylon Locknuts (11). Do not tighten the Nylon Locknuts yet.

Attach the Lower Lat Tower (46) to the Crossbrace (47) with two M8 x 68mm Bolts (1), two M8 Washers (15), and two M8 Nylon Locknuts.

Tighten all Nylon Locknuts used in steps 1–5 now.

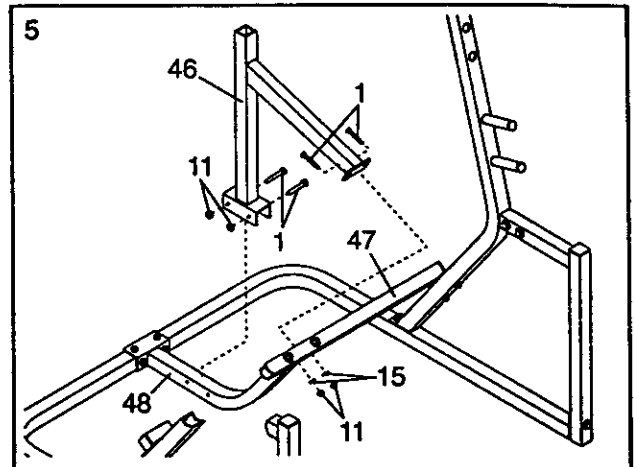

- Press two 60mm Square Bushings (20) into the Weight Carriage (56). Press two 25mm Round Inner Caps (23) into the Weight Carriage.

Press a 60mm Square Bushing (20) into the Carriage Stop (55). The slot in the Square Bushing must be aligned with the indicated hole in the Carriage Stop.

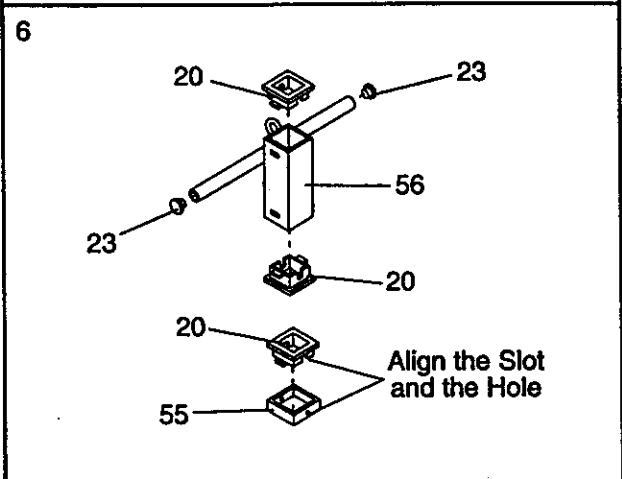

- Slide the Weight Carriage (56) onto the Upper Lat Tower (41). The Weight Carriage must be oriented as shown.

Slide the Carriage Stop (55) onto the Upper Lat Tower (41). The 60mm Square Bushing (20) must be facing toward the Weight Carriage (56). Attach the Carriage Stop to the Upper Lat Tower with an M8 x 68mm Bolt (1) and an M8 Nylon Locknut (11).

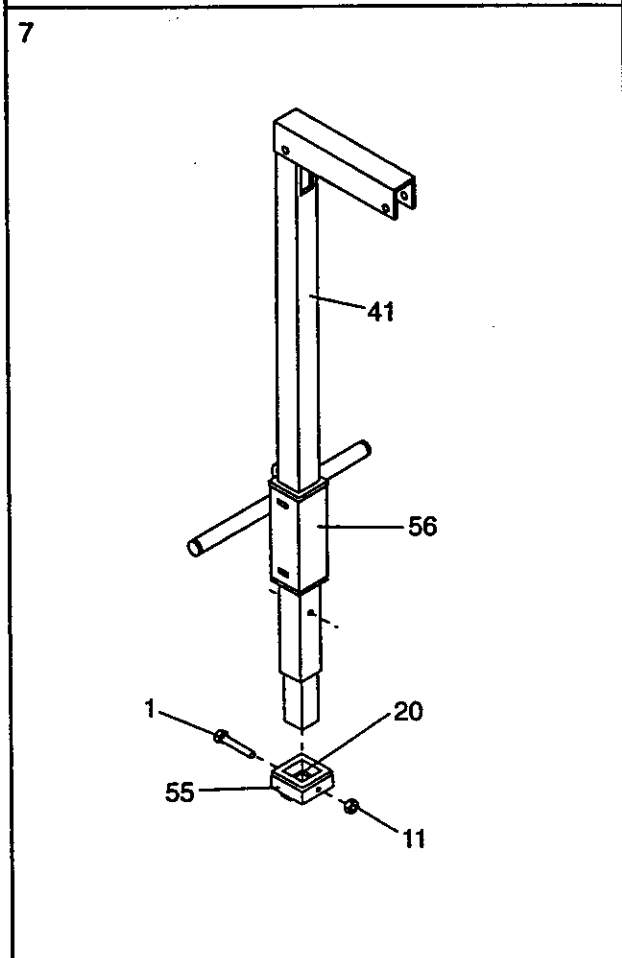

8. Insert the Upper Lat Tower (41) into the Lower Lat Tower (46). Fully tighten the M10 x 63mm Bolt (6) into the Lower Lat Tower.

Slide a Weight Stop (19) onto each side of the Weight Carriage (56).

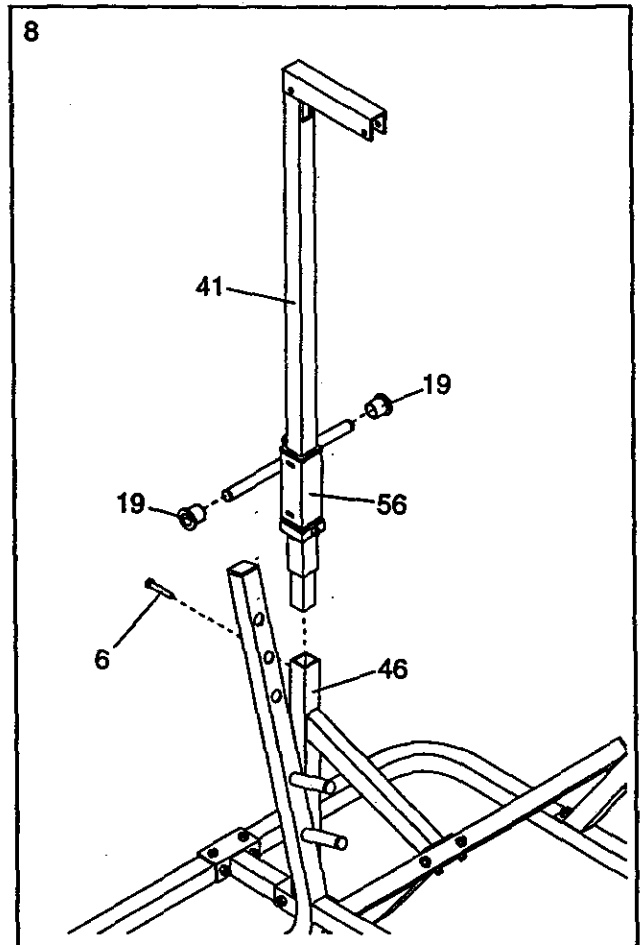

9. Wrap the Cable (32) around a Pulley (45). Attach the Pulley to the Upper Lat Tower (41) with an M10 x 70mm Bolt (2), two M10 Washers (16), two 14mm x 15mm Spacers (14), and an M10 Nylon Locknut (12).

Attach the other Pulley (45) to the Upper Lat Tower (41) in the same manner.

Attach the indicated end of the Cable (32) to the eyebolt on the Weight Carriage (56).

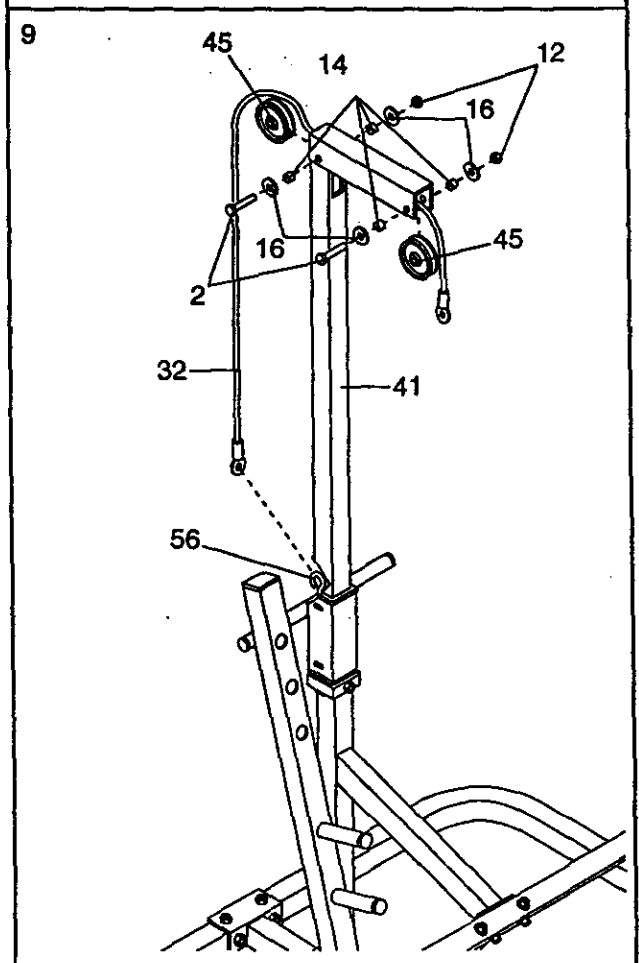

10. Press a 76mm Round Outer Cap (25) onto each side of the Stabilizer (49).

Press two 50mm Square Inner Caps (21) into the Bench Frame (39).

Attach the Stabilizer (49) to the Bench Frame (39) with two M8 x 68mm Bolts (1), two M8 Washers (15), and two M8 Nylon Locknuts (11).

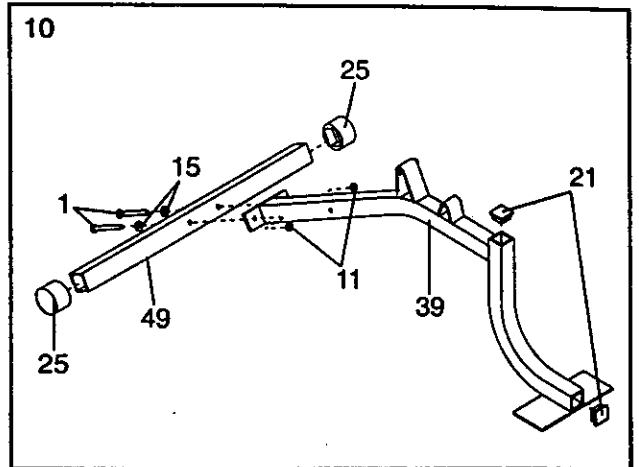

11. Press 20mm x 40mm Inner Caps (27) into the ends of both Backrest Brackets (38).

Lubricate an M10 x 127mm Bolt (4). Using the indicated holes, attach the Backrest Brackets (38) to the Bench Frame (39) with the M10 x 127mm Bolt and an M10 Nylon Locknut (12). The Backrest Brackets must be oriented as shown. Do not overtighten the Nylon Locknut; the Backrest Brackets must be able to move freely.

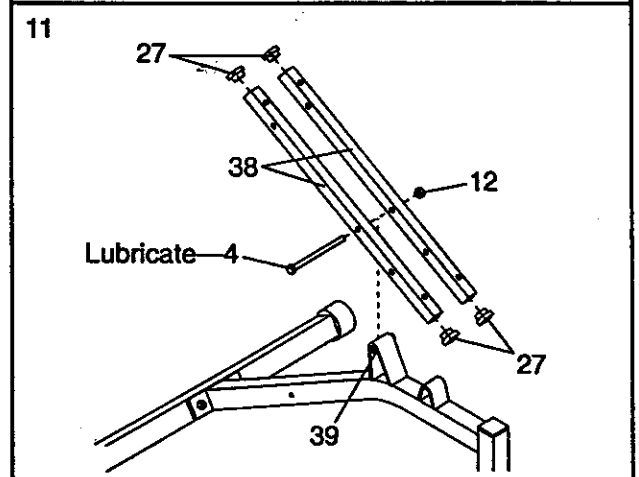

12. Lubricate an M10 x 127mm Bolt (4). Attach the Adjustment Bracket (51) to the Backrest Brackets (38) with the M10 x 127mm Bolt and an M10 Nylon Locknut (12). Do not overtighten the Nylon Locknut; the Backrest Brackets and Adjustment Bracket must be able to move freely.

Align one set of holes in the Adjustment Bracket (51) with the hole in the Bench Frame (39). Insert the "L"-Pin (50) through the Adjustment Bracket and the Bench Frame.

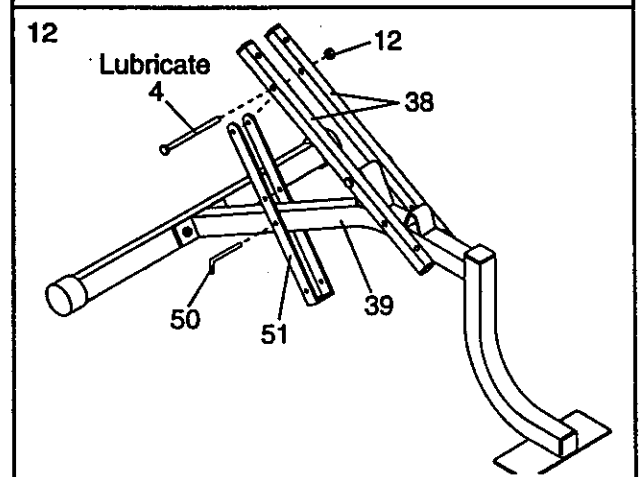

13. Lubricate an M10 x 127mm Bolt (4). Attach the Seat Frame (44) to the Backrest Brackets (38) with the M10 x 127mm Bolt and an M10 Nylon Locknut (12). Do not overtighten the Nylon Locknut; the Backrest Brackets and Seat Frame must be able to move freely.

Press a 38mm x 50mm Inner Cap (22) into the Seat Frame (44).

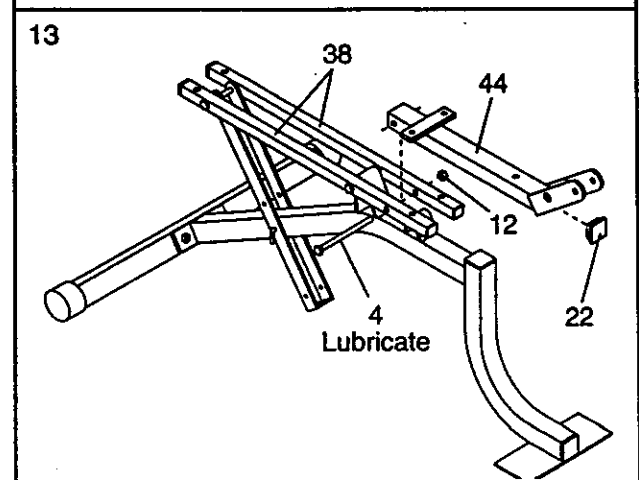

14. Attach the Seat (35) to the Seat Frame (44) with two M6 x 16mm Screws (9), an M6 Washer (17), and the M6 x 50mm Bolt (7).

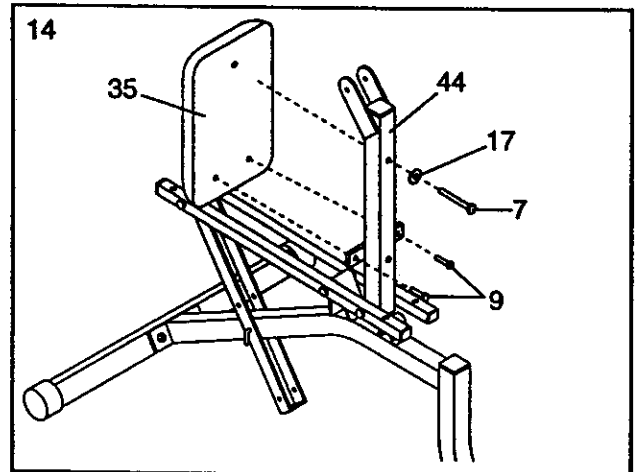

15. Attach the Backrest (36) to the Backrest Brackets (38) with four M6 x 50mm Screws (10).

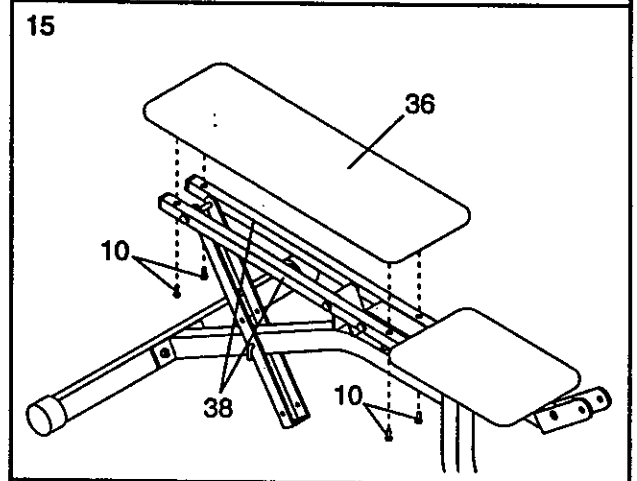

16. Press a 50mm Square Inner Cap (21) into each end of the Leg Lever (28). Press a 25mm Round Inner Cap (23) into the Leg Lever. Press an Angled Round Cap (29) onto the Leg Lever.

Lubricate the M10 x 78mm Bolt (5). Attach the Leg Lever (28) to the Seat Frame (44) with the Bolt and an M10 Nylon Locknut (12).

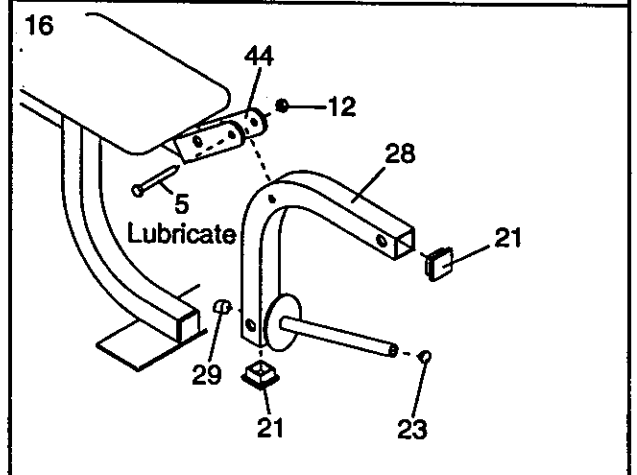

17. Tap 19mm Round Inner Caps (24) into each end of the three Pad Tubes (37).

Insert a Pad Tube (37) through the indicated hole in the Leg Lever (28). Insert another Pad Tube through the other hole in the Leg Lever. Insert the remaining Pad Tube through the holes in the Seat Frame (44).

Slide two Foam Pads (26) onto each Pad Tube (37).

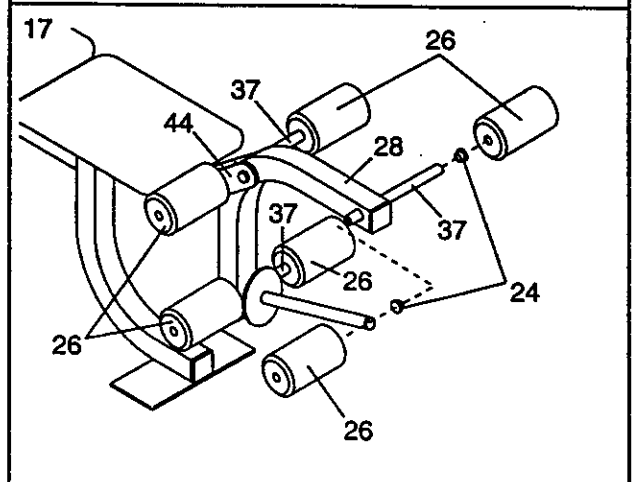

18. Wet the ends of the Lat Bar (31) with soapy water. Slide a Handgrip (18) onto each end of the Lat Bar. **CAUTION: Allow the Handgrips to dry before using them.**

Press 25mm Round Inner Caps (23) into the ends of the Adjustment Weight Rests (54).

Press an Adapter Insert (57) into each end of the Olympic Adapter (58).

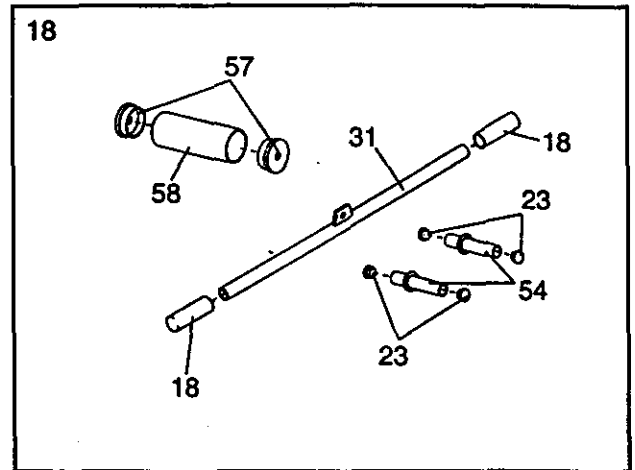

19. Be sure that all parts have been tightened properly. The use of all remaining parts will be explained in **ADJUSTING THE WEIDER PRO 635** beginning on page 12 of this manual.

ADJUSTING THE WEIDER PRO 635

The weight bench is designed to be used with your own weight set (not included). The steps below explain how the weight bench can be adjusted. See EXERCISE GUIDELINES on page 14 for important exercise information and refer to the accompanying exercise poster to see the correct form for each exercise. Refer also to the exercise information accompanying your weight set for additional exercises.

Inspect and tighten all parts each time you use the weight bench. Replace any worn parts immediately. The weight bench can be cleaned with a damp cloth and a mild, non-abrasive detergent. Do not use solvents.

ATTACHING WEIGHTS TO THE WEIGHT CARRIAGE

To use the lat tower, first slide a Weight Stop (19) onto each side of the weight tube of the Weight Carriage (56). Slide the desired amount of weight (not included) onto the weight tube. Be sure that an equal amount of weight is on each side of the weight tube. Secure the weights on each side of the weight tube with a Spring Clip (34).

Do not place more than 150 pounds on the Weight Carriage. (Due to the fact that ab crunches are an aerobic exercise, we recommend that you do not place more than 50 pounds on the Weight Carriage while performing ab crunch exercises.)

ATTACHING WEIGHTS TO THE LEG LEVER

To use the Leg Lever (28), slide the desired amount of weight (not included) onto the weight tube.

If you are using olympic weights, slide the Olympic Adapter (58) onto the Leg Lever (28) before sliding any weight onto the Leg Lever.

Do not place more than 150 pounds on the Leg Lever.

ADJUSTING THE BACKREST

The Backrest (36) can be set at three different positions: the level position, the decline position, and the incline position.

To change the position of the Backrest (36), remove the "L"-Pin (50) from the Adjustment Bracket (51) and the Bench Frame (39). Set the Backrest to the desired position, align the holes in the Adjustment Bracket and the Bench Frame, and re-insert the "L"-Pin.

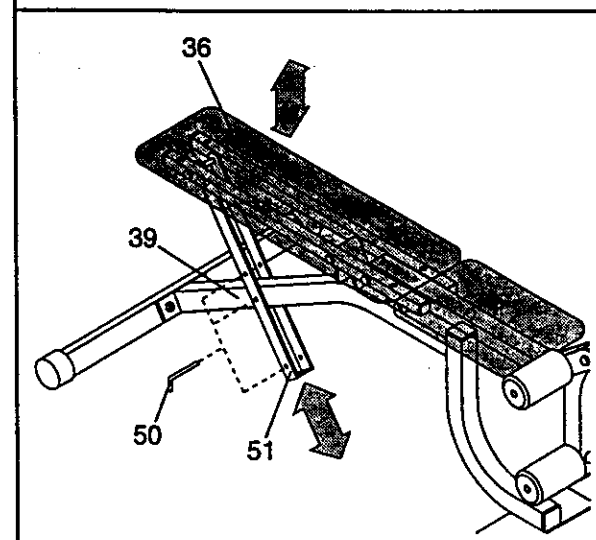
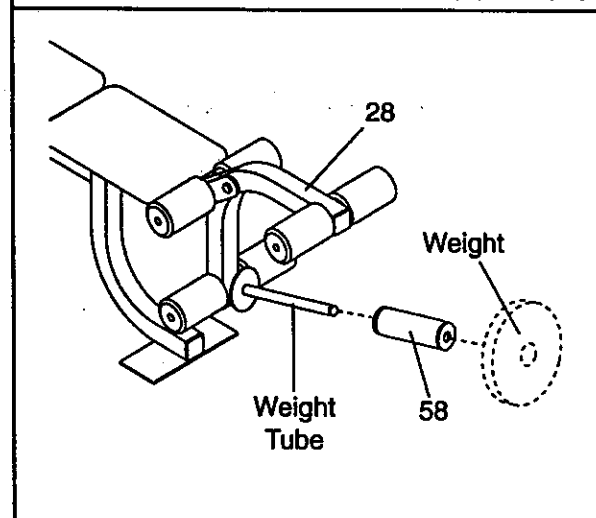
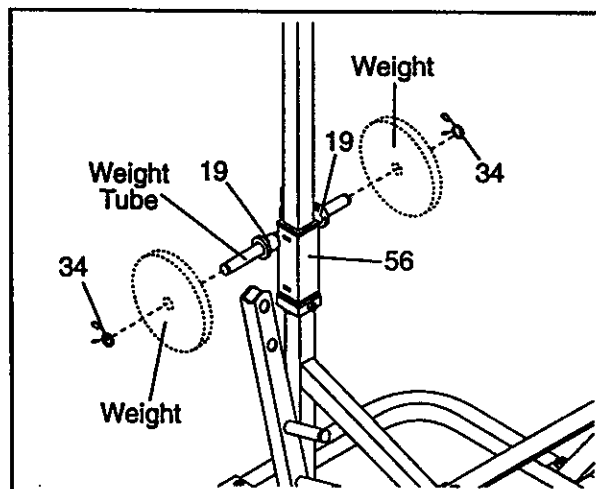

ATTACHING THE LAT BAR TO THE HIGH PULLEY STATION

Attach the Lat Bar (31) to the Cable (32) with a Cable Clip (33).

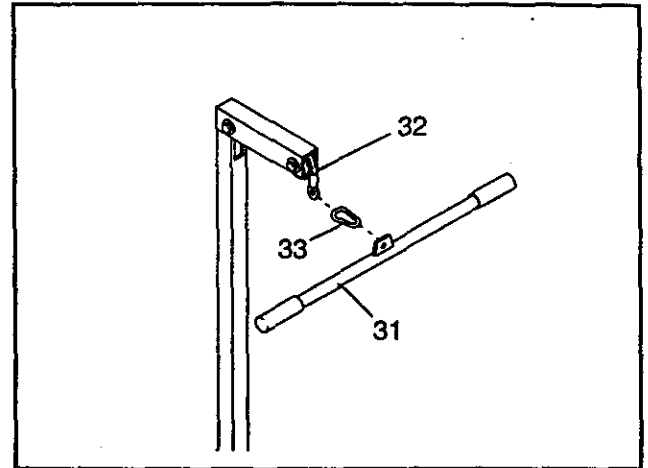

SETTING THE ADJUSTMENT WEIGHT RESTS

To perform squat exercises or toe raise exercises (see the accompanying EXERCISE POSTER) you will need to set the Adjustment Weight Rests (54) to a comfortable height.

Insert the Adjustment Weight Rests (54) into the adjustment holes at the desired height. Be sure that each Adjustment Weight Rest is firmly seated in the adjustment hole and that both Adjustment Weight Rests are at the same height.

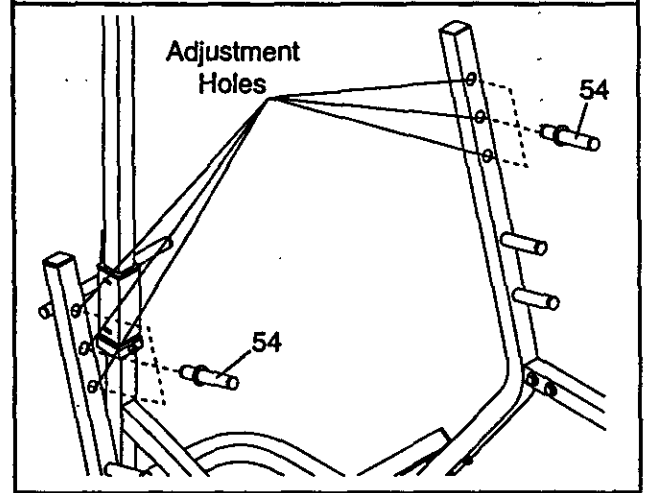

EXERCISE GUIDELINES

THE FOUR BASIC TYPES OF WORKOUTS

• Muscle Building

In order to increase the size and strength of your muscles, you must push your muscles to a high percentage of their capacity. You must also progressively increase the intensity of your exercise so that your muscles will continually adapt and grow. Each individual exercise can be tailored to the proper intensity level by changing the amount of weight used, or the number of repetitions or sets performed. (A "repetition" is one complete cycle of an exercise, such as one sit-up. A "set" is a series of repetitions performed consecutively.)

The proper amount of weight for each exercise depends upon the individual user. It is up to you to gauge your limits. Select the amount of weight that you think is right for you. Begin with 3 sets of 8 repetitions for each exercise that you perform. Rest for 3 minutes after each set. When you can complete 3 sets of 12 repetitions without difficulty, increase the amount of weight.

• Toning

To tone your muscles, you must push your muscles to a moderate percentage of their capacity. Select a moderate amount of weight and increase the number of repetitions in each set. Complete as many sets of 15 to 20 repetitions as possible without discomfort. Rest for 1 minute after each set. Work your muscles by completing more sets rather than by using high amounts of weight.

• Weight Loss

To lose weight, use a low amount of weight and increase the number of repetitions in each set. Exercise for 20 to 30 minutes, resting for a maximum of 30 seconds between sets.

• Cross Training

In the pursuit of a complete and well-balanced fitness program, many have found that cross training is the answer. We recommend that on Monday, Wednesday and Friday, you plan weight training workouts. On Tuesday and Thursday, plan 20 to 30 minutes of aerobic exercise, such as cycling, running or swimming. Rest from both weight training and aerobic exercise for at least one full day each week to give your body time to regenerate. By combining weight training with aerobic exercise, you can reshape and strengthen your body, plus develop a stronger heart and lungs.

PERSONALIZING YOUR EXERCISE PROGRAM

We have not specified an exact length of time for each workout, or a specific number of repetitions or sets for each exercise. It is very important to avoid overdoing it during the first few months of your exercise program, and to progress at your own pace. If you experience pain or dizziness at any time while exercising, stop immediately and begin to cool down. Find out what is wrong before continuing. Remember that adequate rest and a proper diet are also important.

WARMING UP

Begin each workout with 5 to 10 minutes of light stretching and exercise to warm up. Warming up prepares your body for exercise by increasing circulation, raising your body temperature and delivering more oxygen to your muscles.

WORKING OUT

Each workout should include 6 to 10 different exercises. Select exercises for every major muscle group, with emphasis on the areas that you want to develop the most. To give balance and variety to your workouts, vary the exercises from workout to workout.

Schedule your workouts for the time of day when your energy level is the highest. Each workout should be followed by at least one day of rest. Once you find the schedule that is right for you, stick with it.

EXERCISE FORM

In order to obtain the greatest benefits from exercising, it is essential to maintain proper form.

Maintaining proper form means moving through the full range of motion for each exercise, and moving only the appropriate parts of the body. Exercising in an uncontrolled manner will leave you feeling exhausted. On the exercise poster accompanying this manual, you will find photographs showing the correct form for several exercises. A description of each exercise is also provided, along with a list of the muscles affected. Refer to the muscle chart on page 16 to find the locations of the muscles.

The repetitions in each set should be performed smoothly and without pausing. The exertion stage of each repetition should last about half as long as the return stage. Proper breathing is important. Exhale during the exertion stage of each repetition and inhale during the return stroke; never hold your breath. Rest for 3 minutes after each set if you are doing a muscle building workout, 1 minute after each set if you are

doing a toning workout, and 30 seconds after each set if you are doing a weight loss workout. Plan to spend the first couple of weeks familiarizing yourself with the equipment and learning the proper form for each exercise.

COOLING DOWN

End each workout with 5 to 10 minutes of stretching. Include stretches for both your arms and legs. Move slowly as you stretch—do not bounce. Ease into each stretch gradually and go only as far as you can without strain. Stretching at the end of each workout is very effective for increasing flexibility.

STAYING MOTIVATED

For motivation, keep a record of each workout. The chart on page 17 of this manual can be photocopied and used to schedule and record your workouts. List the date, exercises performed, weight, and numbers of sets and repetitions completed. Record your weight and key body measurements at the end of every month.

Remember, the key to achieving the greatest results is to make exercise a regular and enjoyable part of your everyday life.

MUSCLE CHART

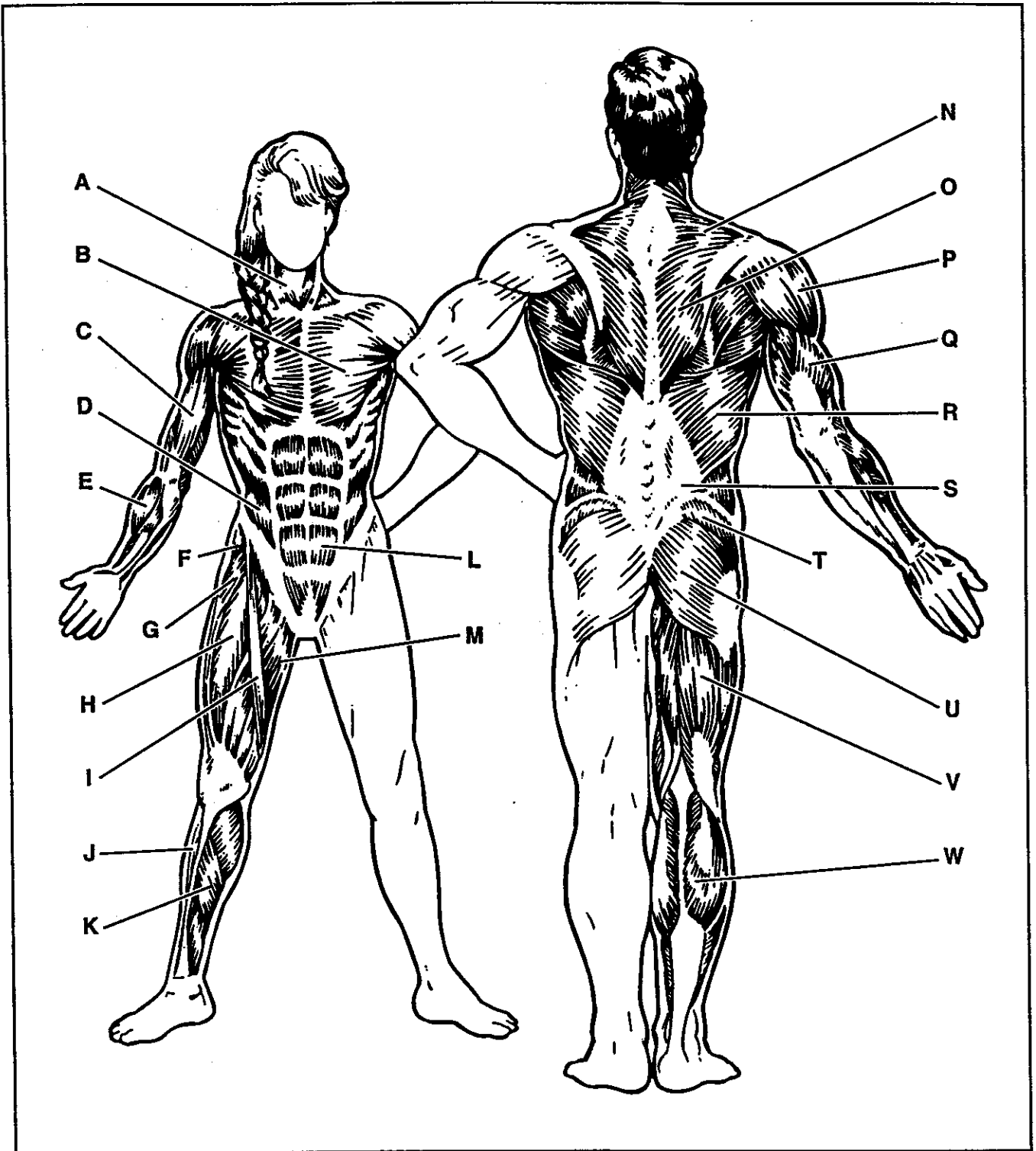

- | | | |
|--------------------------------|--------------------------------------|---------------------------------|
| A. Sternomastoid (neck) | I. Sartorius (front of thigh) | Q. Triceps (back of arm) |
| B. Pectoralis Major (chest) | J. Tibialis Anterior (front of calf) | R. Latissimus Dorsi (mid back) |
| C. Biceps (front of arm) | K. Soleus (front of calf) | S. Spinae Erectors (lower back) |
| D. Obliques (waist) | L. Rectus Abdominus (stomach) | T. Gluteus Medius (hip) |
| E. Brachioradials (forearm) | M. Adductor (inner thigh) | U. Gluteus Maximus (buttocks) |
| F. Hip Flexors (upper thigh) | N. Trapezius (upper back) | V. Hamstring (back of leg) |
| G. Abductor (outer thigh) | O. Rhomboideus (upper back) | W. Gastrocnemius (back of calf) |
| H. Quadriceps (front of thigh) | P. Deltoid (shoulder) | |

MONDAY Date: / /	EXERCISE	WEIGHT	SETS	REPS

TUESDAY **AEROBIC EXERCISE**
Date: / /

WEDNESDAY Date: / /	EXERCISE	WEIGHT	SETS	REPS

THURSDAY **AEROBIC EXERCISE**
Date: / /

FRIDAY Date: / /	EXERCISE	WEIGHT	SETS	REPS

Make photocopies of this page for scheduling and recording your workouts.

PART LIST—Model No. 831.150390

R0896A

Key No.	Qty.	Part No.	Description	Key No.	Qty.	Part No.	Description
1	21	013374	M8 x 68mm Bolt	31	1	132687	Lat Bar
2	2	132651	M10 x 70mm Bolt	32	1	132679	Cable
3	4	132652	M8 x 60mm Carriage Bolt	33	1	103087	Cable Clip
4	3	132653	M10 x 127mm Bolt	34	2	130312	Spring Clip
5	1	132654	M10 x 78mm Bolt	35	1	132188	Seat
6	1	132889	M10 x 63mm Bolt	36	1	132189	Backrest
7	1	132656	M6 x 50mm Bolt	37	3	132666	Pad Tube
8	—	—	Not used	38	2	132680	Backrest Bracket
9	2	013431	M6 x 16mm Screw	39	1	132668	Bench Frame
10	4	132658	M6 x 50mm Screw	40	1	132672	Right Base
11	25	012042	M8 Nylon Locknut	41	1	132662	Upper Lat Tower
12	6	012077	M10 Nylon Locknut	42	2	132663	Weight Upright
13	—	—	Not used	43	2	132681	Front Upright
14	4	019020	14mm x 15mm Spacer	44	1	132667	Seat Frame
15	20	014172	M8 Washer	45	2	115370	Pulley
16	4	130286	M10 Washer	46	1	132661	Lower Lat Tower
17	1	014033	M6 Washer	47	1	132669	Crossbrace
18	2	119702	Handgrip	48	1	132665	Lat Base
19	2	123403	Weight Stop	49	1	132670	Stabilizer
20	3	127941	60mm Square Bushing	50	1	132682	"L"-Pin
21	10	120720	50mm Square Inner Cap	51	1	132684	Adjustment Bracket
22	1	117544	38mm x 50mm Inner Cap	52	—	—	Not used
23	15	120733	25mm Round Inner Cap	53	1	132671	Left Base
24	6	113667	19mm Round Inner Cap	54	2	132673	Adjustment Weight Rest
25	2	132686	76mm Round Outer Cap	55	1	132683	Carriage Stop
26	6	103805	Foam Pad	56	1	132660	Weight Carriage
27	4	132685	20mm x 40mm Inner Cap	57	2	128739	Adapter Insert
28	1	132659	Leg Lever	58	1	132888	Olympic Adapter
29	1	123396	Angled Round Cap	#	1	132486	User's Manual
30	4	132688	Spring Clip Cover	#	1	131065	Exercise Poster

Note: "#" indicates a non-illustrated part. Specifications are subject to change without notice. See the back cover of this manual for information about ordering replacement parts.

EXPLODED DRAWING—Model No. 831.150390

R0896A

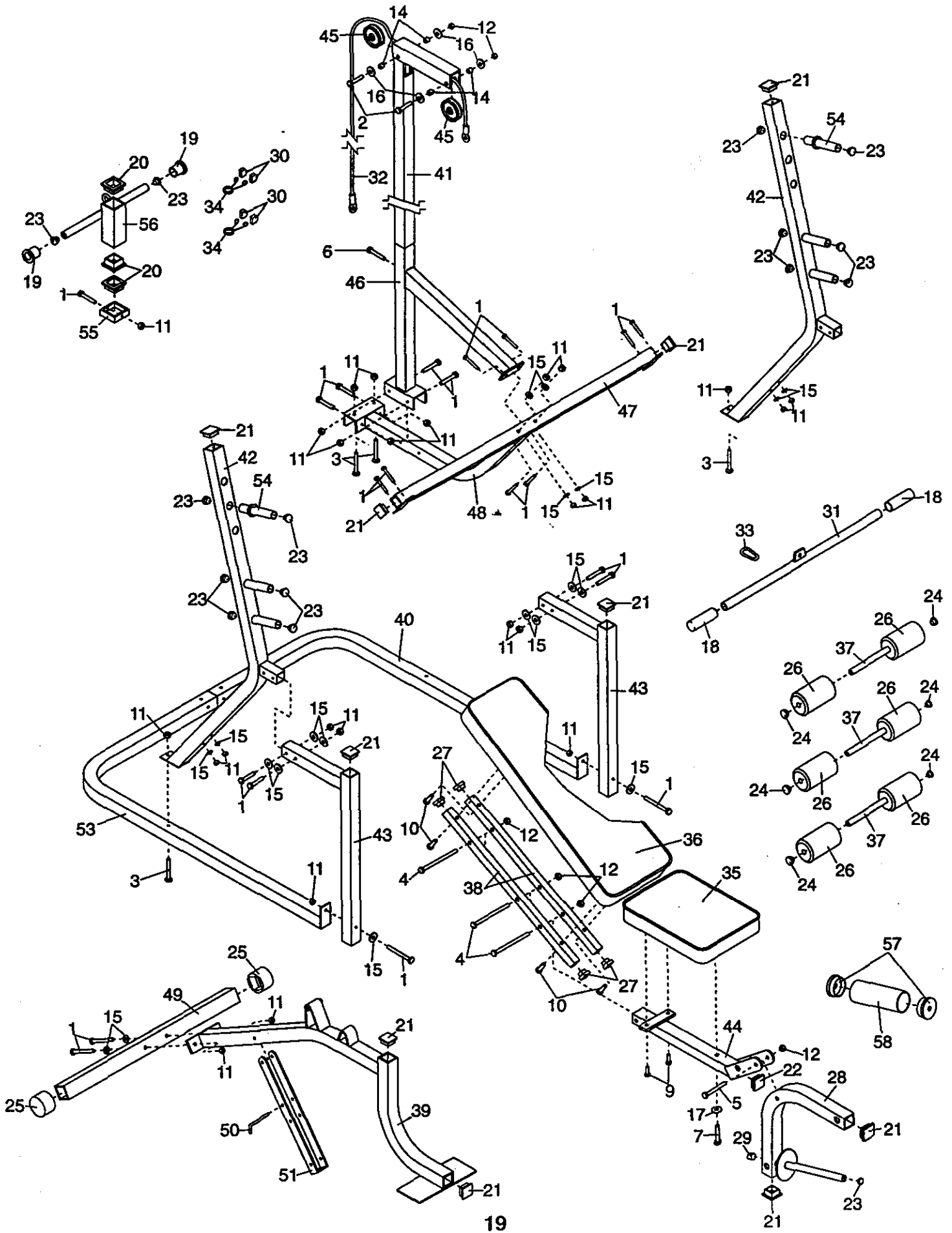

REMOVE THIS PART IDENTIFICATION CHART FROM THE MANUAL

This chart is provided to help you identify the small parts used in assembly. **Important: Some parts may have been pre-assembled for shipping purposes. If you cannot find a part in the parts bags, check to see if it has been pre-assembled.** The number in parenthesis below each part refers to the key number of the part. The second number refers to the quantity needed for assembly.

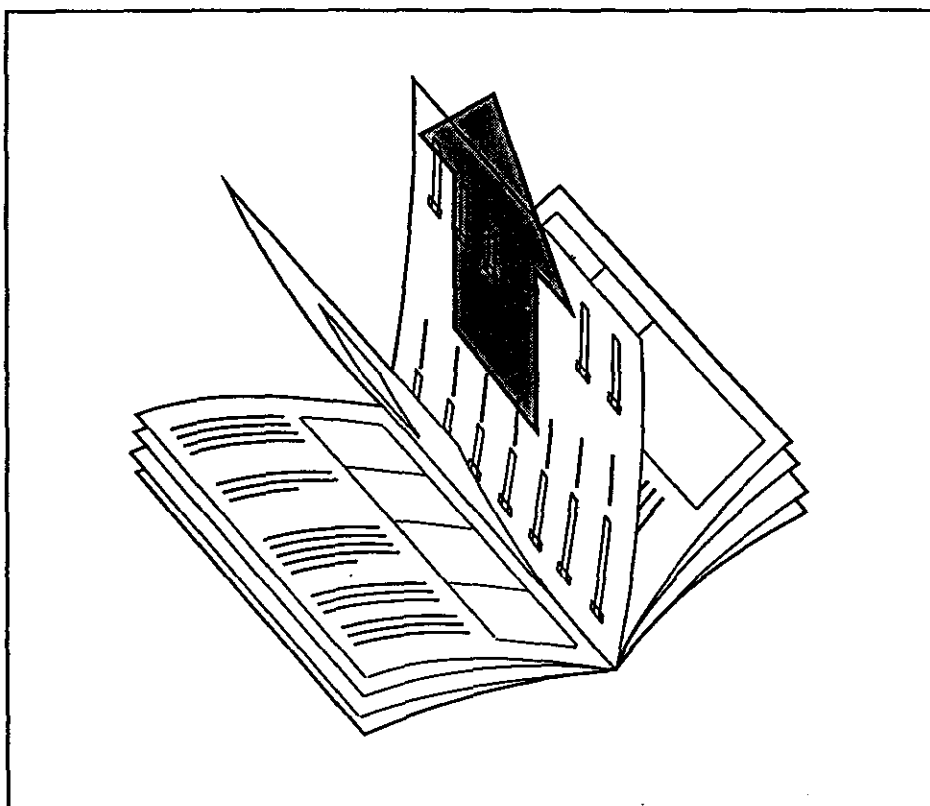

SEARS MODEL NO: 831.150390
PRODUCT NAME: WEIDER PRO 635
PRODUCT DESC:

RUN DATE: 10/11/96
RUN TIME: 8:03:40

KEY NUMBER	PART NUMBER	DESCRIPTION	COST
1	013374	M8 X 68MM BOLT	.00
2	132651	M10 X 70MM BOLT	.00
3	132652	M8 X 60MM CARRIAGE BOLT	.00
4	132653	M10 X 127MM BOLT	.00
5	132654	M10 X 78MM BOLT	.00
6	132889	M10 X 63MM BOLT	.00
7	132656	M6 X 50MM BOLT	.00
8	.	KEY# NOT USED	.00
9	013431	M6 X 16MM SCREW	.00
10	132658	M6 X 50MM SCREW	.00
11	012042	M8 NYLON LOCKNUT	.00
12	012077	M10 NYLON LOCKNUT	.00
13	.	KEY# NOT USED	.00
14	019020	14MM X 15MM SPACER	.00
15	014172	M8 WASHER	.00
16	130286	M10 WASHER	.00
17	014033	M6 WASHER	.00
18	119702	HAND GRIP	.00
19	123403	WEIGHT STOP	.00
20	127941	60MM SQUARE BUSHING	.00
21	120720	50MM SQUARE INNER CAP	.00
22	117544	38MM X 50MM INNER CAP	.00
23	120733	25MM ROUND INNER CAP	.00
24	113667	19MM ROUND INNER CAP	.00
25	132686	76MM ROUND OUTER CAP	.00
26	103805	FOAM PAD	.00
27	132685	20MM X 40MM INNER CAP	.00
28	132659	LEG LEVER	.00
29	123396	ANGLED ROUND CAP	.00
30	132688	SPRING CLIP COVER	.00
31	132687	LAT BAR	.00
32	132679	CABLE	.00
33	103087	CABLE CLIP	.00
34	130312	SPRING CLIP	.00
35	132188	SEAT	.00
36	132189	BACKREST	.00
37	132666	PAD TUBE	.00
38	132680	BACKREST BRACKET	.00
39	132668	BENCH FRAME	.00
40	132672	RIGHT BASE	.00
41	132662	UPPER LAT TOWER	.00
42	132663	WEIGHT UPRIGHT	.00
43	132681	FRONT UPRIGHT	.00
44	132667	SEAT FRAME	.00
45	115370	PULLEY	.00
46	132661	LOWER LAT TOWER	.00
47	132669	CROSSBRACE	.00
48	132665	LAT BASE	.00
49	132670	STABILIZER	.00
50	132682	L-PIN	.00
51	132684	ADJUSTMENT BRACKET	.00
52	.	KEY# NOT USED	.00
53	132671	LEFT BASE	.00
54	132673	ADJUSTMENT WEIGHT REST	.00

SEARS MODEL NO: 831.150390
 PRODUCT NAME: WEIDER PRO 635
 PRODUCT DESC:

RUN DATE: 10/11/96
 RUN TIME: 8:03:40

KEY NUMBER	PART NUMBER	DESCRIPTION	COST
55	132683	CARRIAGE STOP	.00
56	132660	WEIGHT CARRIAGE	.00
57	128739	ADAPTER INSERT	.00
58	132888	OLYMPIC ADAPTER	.00
.	.	NON-ILLUSTRATED PARTS	.00
#	133121	CN - WELDED BRACKET	.00
#	131065	EXERCISE POSTER	.00
#	132486	USER'S MANUAL	.00
#	134428	LITERATURE PACKET	.00
.	.	132486 USER'S MANUAL	.00
.	.	131065 EXERCISE POSTER	.00
.	.	133121 CN-WELDED BRACKET	.00
#	134426	HARDWARE KIT	.00
.	.	013374 M8 SCREW	.00
.	.	132651 M10 SCREW	.00
.	.	132652 M8 CARRIAGE BOLT	.00
.	.	132653 M10 SCREW	.00
.	.	132654 M10 SCREW	.00
.	.	132889 M8 SCREW	.00
.	.	013431 M6 SCREW	.00
.	.	132658 M6 SCREW	.00
.	.	012042 M8 NUT	.00
.	.	012077 M10 NUT	.00
.	.	019020 SPACER	.00
.	.	014172 M8 WASHER	.00
.	.	130286 M10 WASHER	.00
.	.	014033 M6 WASHER	.00
.	.	103087 CABLE CLIP	.00
.	.	132682 L-PIN	.00
#	134427	HARDWARE KIT, PLASTICS	.00
.	.	119702 FOAM GRIP	.00
.	.	123403 WEIGHT STOP	.00
.	.	127941 2.5" BUSHING	.00
.	.	120720 2" SQ ENDCAP	.00
.	.	117544 1.5" X 2" ENDCAP	.00
.	.	120733 1" ROUND ENDCAP	.00
.	.	113667 3/4" ROUND ENDCAP	.00
.	.	132686 50MM SQUARE ENDCAP	.00
.	.	132685 20MM X 40MM ENDCAP	.00
.	.	123396 1" ROUND ENDCAP	.00
.	.	130312 1" SPRING RETAINER	.00
.	.	115370 3.5" PULLEY	.00
.	.	132683 CARRIAGE STOP	.00
.	.	128739 WEIGHT BUSHING	.00



M8 Nylon Locknut (11)-25



M10 Nylon Locknut (12)-6

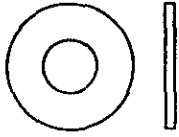

M6 Washer (17)-1

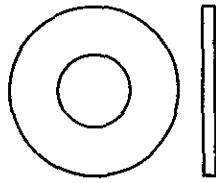

M8 Washer (15)-20

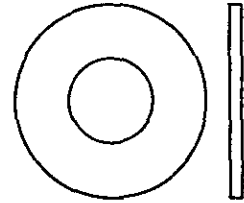

M10 Washer (16)-4

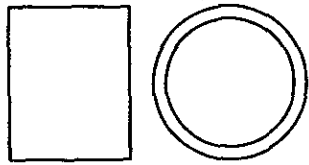

14mm x 15mm Spacer (14)-4

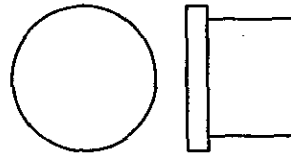

19mm Round Inner Cap (24)-6



M6 x 50mm Screw (10)-4



M6 x 16mm Screw (9)-2

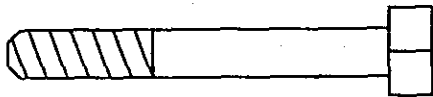

M6 x 50mm Bolt (7)-1

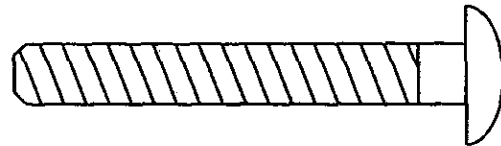

M8 x 60mm Carriage Bolt (3)-4

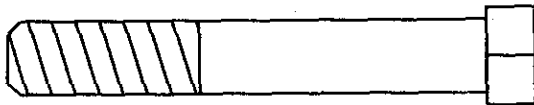

M10 x 63mm Bolt (6)-1

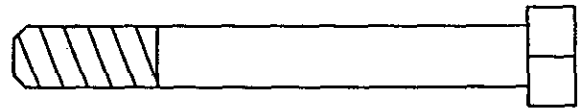

M8 x 68mm Bolt (1)-21

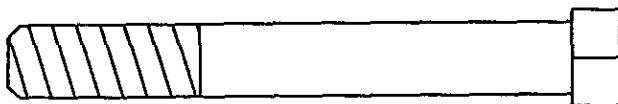

M10 x 78mm Bolt (5)-1

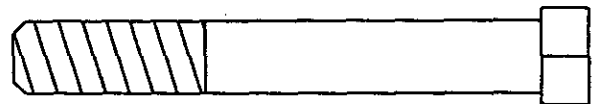

M10 x 70mm Bolt (2)-2

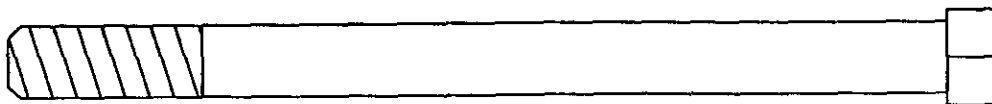

M10 x 127mm Bolt (4)-3

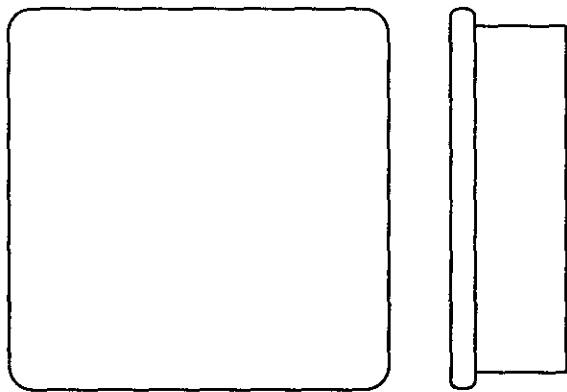

50mm Inner Cap (21)-10

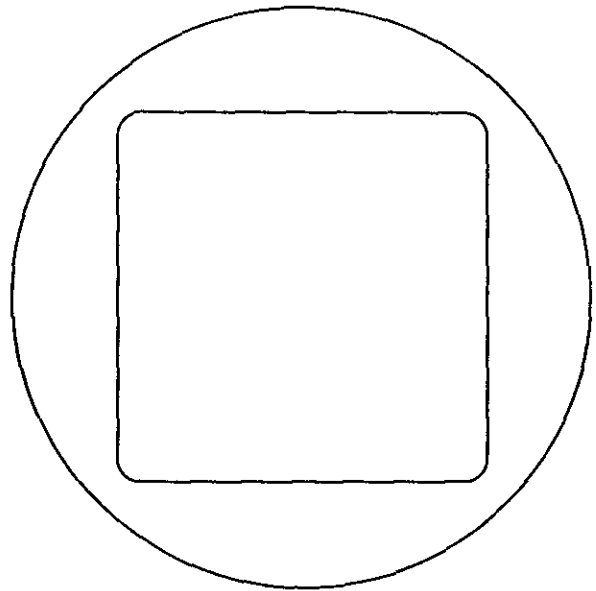

76mm Round Outer Cap (25)-2

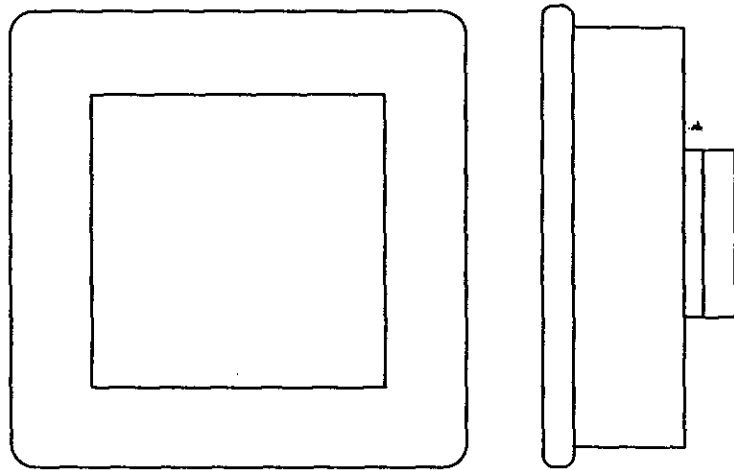

60mm Square Bushing (20)-3

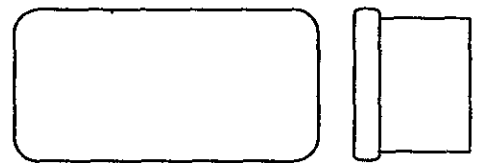

20mm x 40mm Inner Cap (27)-4

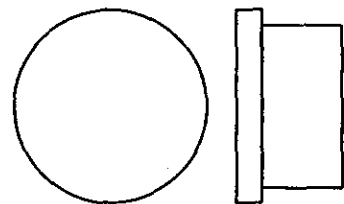

25mm Round Inner Cap (23)-15

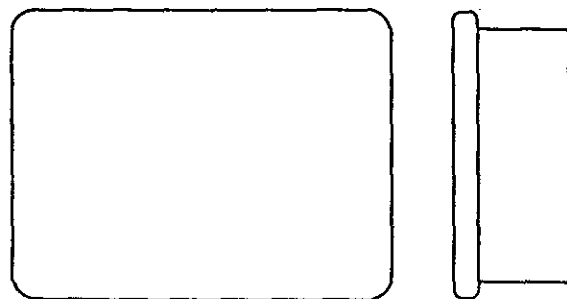

38mm x 50mm Inner Cap (22)-1

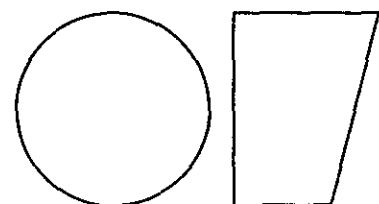

Angled Round Cap (29)-1



Model No. 831.150390

QUESTIONS?

If you find that:

- you need help assembling or operating the WEIDER® PRO 635
- a part is missing
- or you need to schedule repair service

call our toll-free HELPLINE

1-800-736-6879

Monday–Saturday, 7 am–7 pm
Central Time (excluding holidays)

REPLACEMENT PARTS

If parts become worn and need to be replaced, call the following toll-free number

1-800-FON-PART
(1-800-366-7278)

The model number and serial number of your WEIDER® PRO 635 are listed on a decal attached to the frame. See the front cover of this manual to find the location of the decal.

All replacement parts are available for immediate purchase or special order when you visit your nearest SEARS Service Center. To request service or to order parts by telephone, call the toll-free numbers listed at the left.

When requesting help or service, or ordering parts, please be prepared to provide the following information:

- The MODEL NUMBER of the product (831.150390).
- The NAME of the product (WEIDER® PRO 635 Weight Bench).
- The PART NUMBER of the PART (see the PART LIST and the EXPLODED DRAWING on pages 18 and 19 of this manual).
- The DESCRIPTION of the PART (see the PART LIST and the EXPLODED DRAWING on pages 18 and 19 of this manual).

SEARS, ROEBUCK AND CO., HOFFMAN ESTATES, IL 60179