

# Owner's Manual

Model No.  
139.53669SRT

For Residential and  
Light Duty  
Commercial Use

Install on Sectional  
Doors Only

**Caution:**  
Read and follow all  
safety rules and  
operating instructions  
before first use of this  
product.

Fasten the manual  
near the garage door  
after installation.

Complies with UL 325  
regulations effective  
January 1, 1993

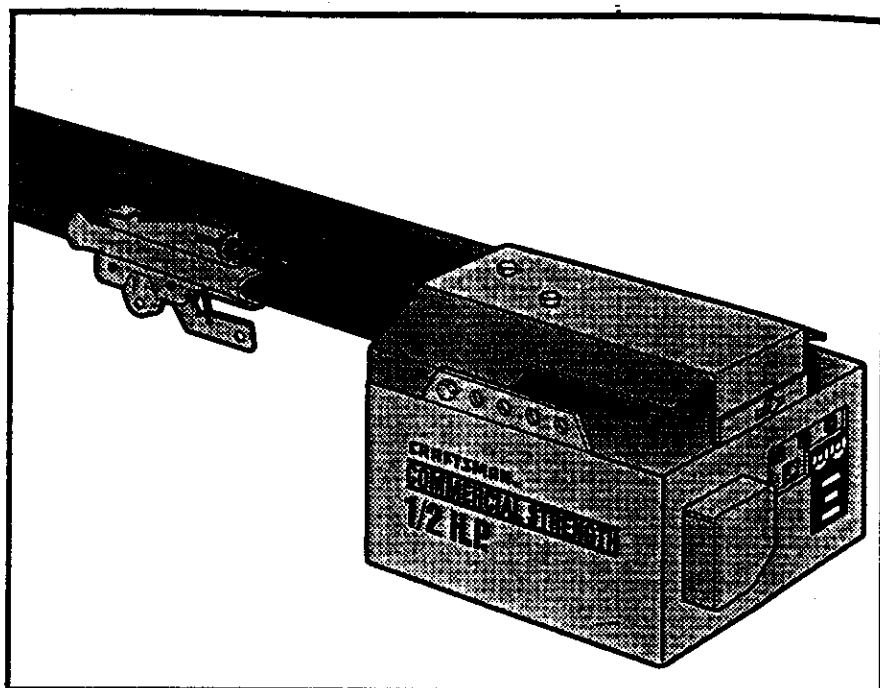

## **CRAFTSMAN®** **GARAGE DOOR OPENER**

- Safety Precautions
- Assembly
- Installation
- Adjustment
- Care and Maintenance
- Operation
- Troubleshooting
- Parts List

Contents	Page	Contents	Page
A review of safety alert symbols.....	2	Attach emergency release rope and handle .....	17
You'll need tools .....	3	Electrical requirements .....	18
Safety information.....	3	Safety reversing sensor information .....	19
Testing your garage door for sticking, binding and balance .....	3	Install the safety reversing sensor .....	20, 21
Illustration of sectional door installation .....	4	Fasten door bracket .....	22
Carton inventory .....	5	Connect door arm to trolley.....	23
Hardware inventory .....	6	<b>Adjustment section - pages 24 – 26</b>	
<b>Assembly section - pages 7 – 10</b>		Travel limit adjustments .....	24
Assemble rail .....	7	Force adjustments .....	25
Attach chain pulley bracket.....	7	Test the safety reversing sensor.....	26
Install trolley.....	8	Test the safety reverse system .....	26
Fasten rail to opener.....	8	Operation safety instructions .....	27
Install chain.....	9	Care of your opener .....	27
Attach rail support bracket.....	9	Maintenance schedule .....	27
Tighten the chain .....	10	Operation of your opener .....	28
<b>Installation section - pages 10 – 23</b>		Receiver and remote control programming.....	29
Installation safety instructions.....	10	Having a problem? .....	30, 31
Determine header bracket location.....	11	Repair parts, rail assembly .....	32
Install the header bracket .....	12	Repair parts, installation .....	32
Attach the rail to header bracket.....	13	Repair parts, opener assembly .....	33
Position the opener.....	14	Accessories.....	34
Hang the opener .....	15	Index .....	35
Install the door control .....	16	How to order repair parts .....	36
Install the light.....	17	Warranty .....	36

**Start by reviewing these important safety alert symbols**

When you see these Safety Symbols on the following pages, they will alert you to the possibility of *serious injury or death* if you do not comply with the corresponding instructions. The hazard may come from something mechanical or from electric shock. *Read the instructions carefully.*



**Mechanical**



**Electrical**

When you see this Safety Symbol on the following pages, it will alert you to the possibility of damage to your garage door and/or the garage door opener if you do not comply with the corresponding instructions. *Read the instructions carefully.*



This garage door opener is designed and tested to offer safe service provided it is installed, operated, maintained and tested in strict accordance with the safety instructions contained in this manual.

# You'll Need Tools

During assembly, installation and adjustment of the opener, instructions will call for hand tools shown below.

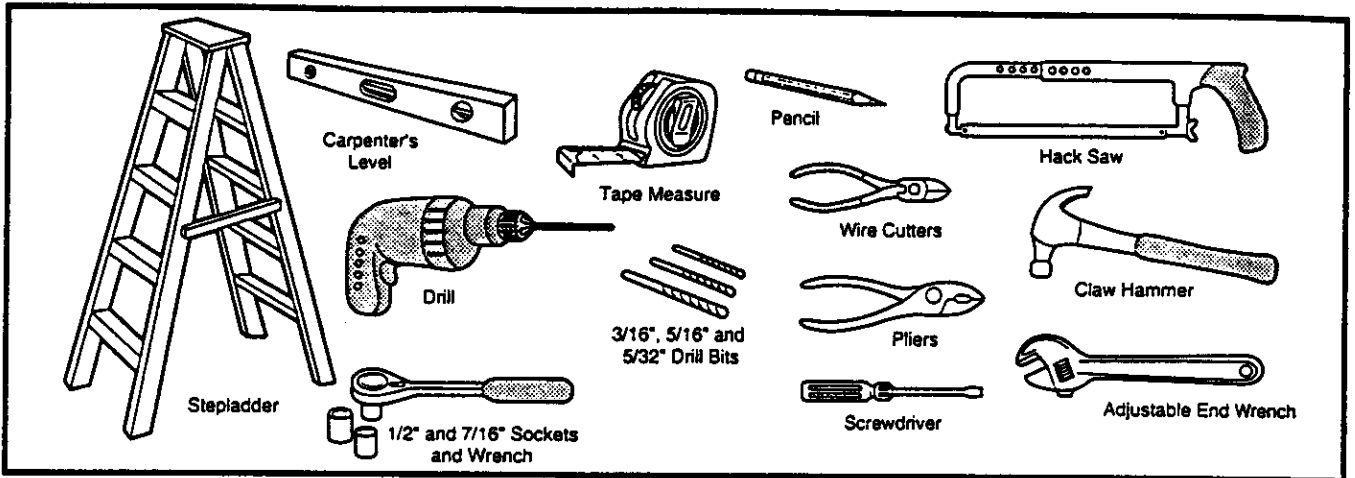

## **WARNING**

*An unbalanced garage door might not reverse when required and someone under the door could be seriously injured or killed.*

If your garage door binds, sticks or is out of balance, call for professional garage door service. *Garage doors, door springs, cables, pulleys, brackets and their hardware, are under extreme tension and can cause serious injury or death. Do not try to loosen, move or adjust them yourself!*

*Ropes left on a garage door could cause someone to become entangled and killed. Remove all ropes connected to the door before installing and operating the opener.*

*This product is for use on sectional garage doors only. Serious personal injury could result from the use of this product on one-piece garage doors.*

## **CAUTION**

To avoid damage to the garage door and opener, disable locks before installing and operating the opener. Use a wood screw or nail to hold locks in the "open" (unlocked) position. Operation at other than 120V 60 Hz will cause opener malfunction and damage.

Identify the type and height of your door, any special conditions that exist, and any additional materials that may be required by referring to the list on page 4.

Before you begin, complete the following test to make sure your door is balanced, and is not sticking or binding:

- Lift the door about halfway as shown. Release the door. It should stay in place, supported entirely by its springs.
- Raise and lower the door to see if there is any binding or sticking.

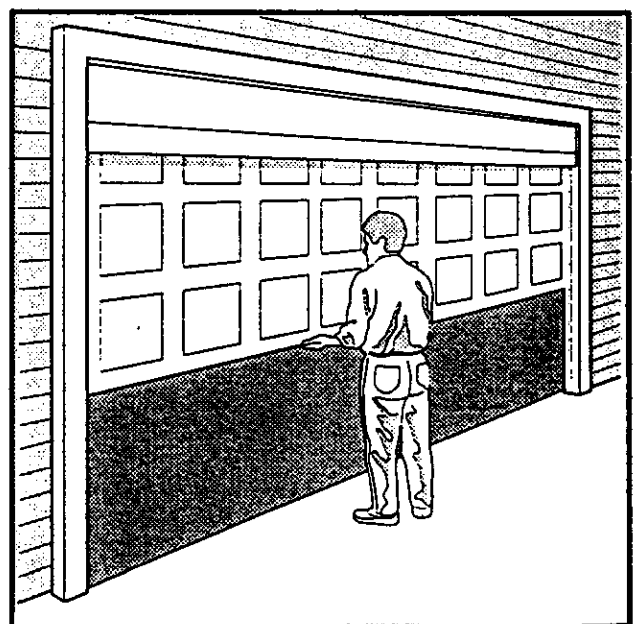

**Before you begin, survey your garage area. Do any of the following conditions apply to you?**

**Before you begin, survey your garage area to see whether any of the conditions below apply to your installation.**

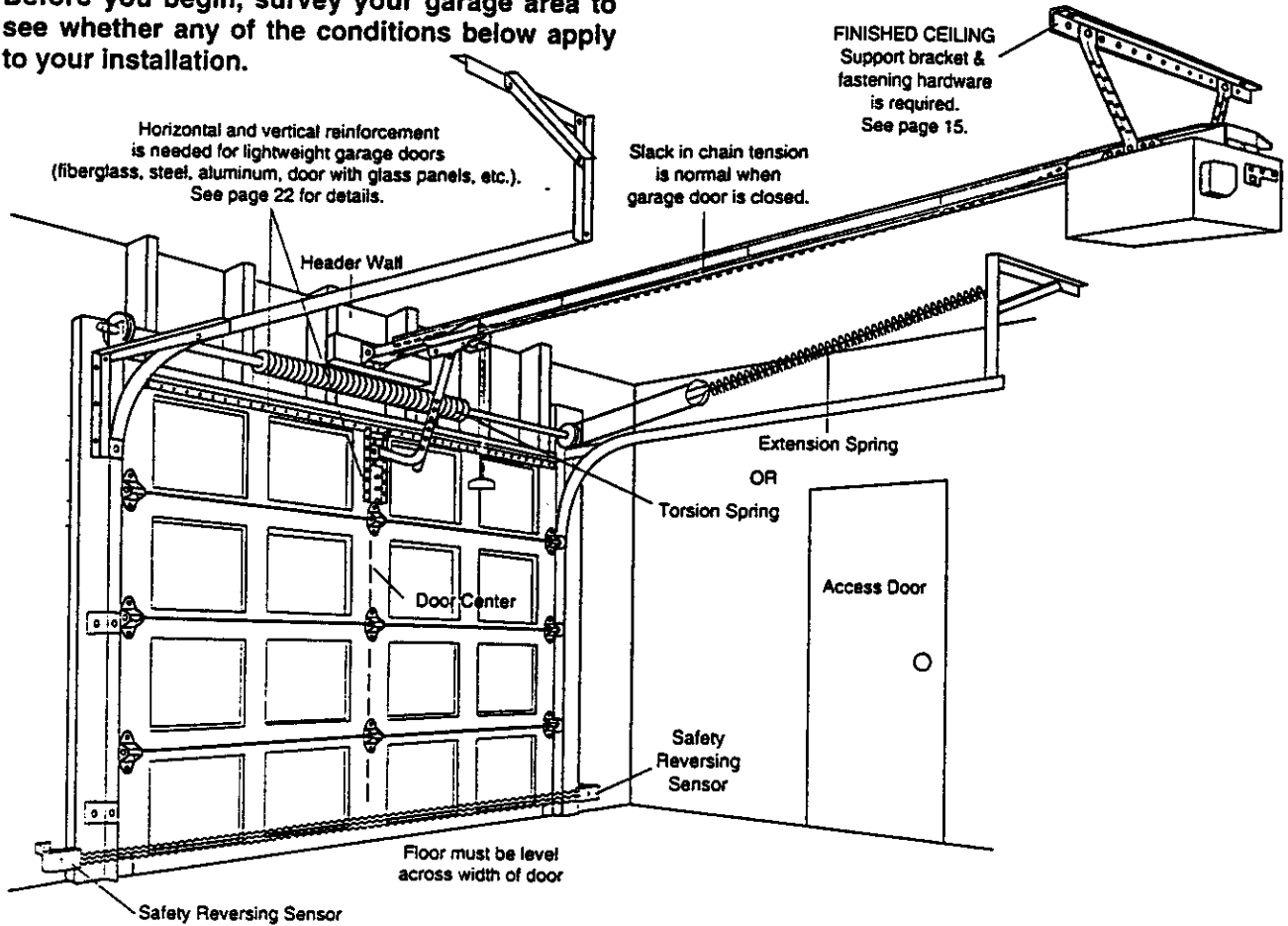

Based on your particular requirements, there are several installation steps which might call for materials and/or hardware not included in the carton.

- Step 1, page 11 - Look at the wall or ceiling above the garage door. The header bracket *must* be securely fastened to structural supports.
- Step 5, page 15 - Do you have a finished ceiling in your garage? If so, a support bracket and additional fastening hardware may be required.
- Safety reversing sensor, page 19 - Depending upon garage construction, wood blocks may need to be fastened to mounting locations before sensors are installed.
- Step 10, page 20 - Alternate floor mounting of the safety reversing sensor will require hardware not provided.
- Step 11, page 22 - Do you have a steel, aluminum, fiberglass or glass panel door? If so, horizontal and vertical reinforcement is required.
- Look at the garage door where it meets the floor. It must close on the floor all the way across. Otherwise, the safety reverse system may not work properly. Floor or door should be repaired. See page 26.

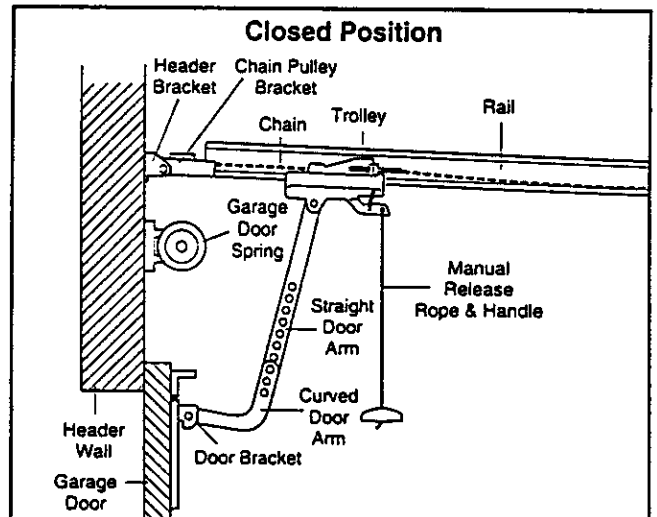

- The opener can be installed within 2 feet to the left or right of the door center if there is a torsion spring or center bearing plate in the way of the header bracket or door bracket area. *If your door has extension springs, the opener must be installed in the center of the door.* See pages 11 and 22.

Do you have an access door in addition to the garage door? If not, Model 53702 Emergency Key Release is required. See page 34.

You may find it helpful to refer back to this page as you proceed with the installation of your opener.

# Carton Inventory

Your garage door opener is packaged in two cartons which contain all parts illustrated below. If anything is missing, carefully check the packing material. Parts may be "stuck" in the foam. Hardware for assembly and installation is shown on page 6.

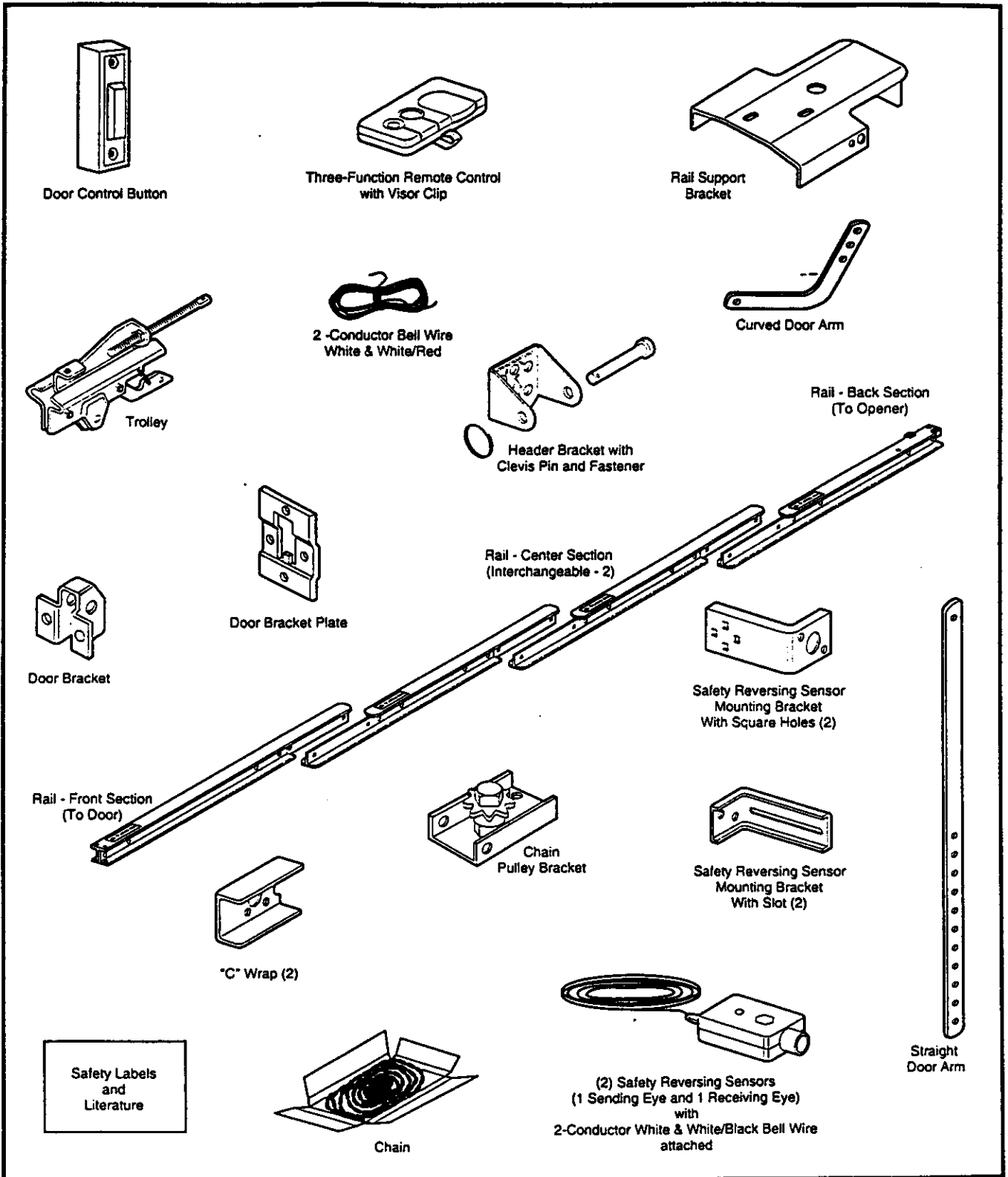

Separate all hardware from the packages in the rail carton and the opener carton, as shown below, for the assembly and installation procedures.

### Assembly Hardware



Hex Screw  
1/4"-20x5/8" (2)

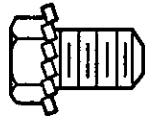

Washed Screw  
5/16"-18x1/2" (4)  
(2 -mounted in opener)



Carriage Bolt  
1/4"-20x1/2" (7)



Screw  
#8-32x3/8" (1)



Lock Washer  
1/4" (2)



Master Link (2)



Hex Screw  
5/16"-18x7/8" (3)

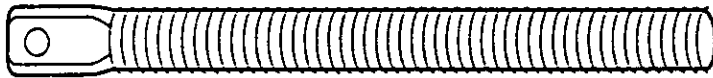

Trolley Threaded Shaft (1)



Lock Washer  
5/16" (4)



Nut  
5/16"-18 (5)



Lock Nut  
1/4"-20 (7)

### Installation Hardware



Lag Screw  
5/16"-9x1-5/8" (4)



Handle



Rail Grease



Rope



Hex Screw  
5/16"-18x7/8" (4)



Nut 5/16"-18 (6)



Ring  
Fastener (3)



Lock Washer 5/16" (6)

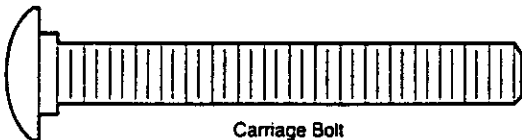

Carriage Bolt  
5/16"-18x2-1/2" (2)



Screw  
6ABx1-1/2" (2)



Insulated  
Staples (10)

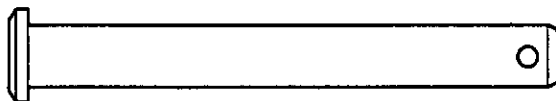

Clevis Pin  
5/16"x2-3/4" (1)

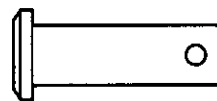

Clevis Pin  
5/16"x1" (2)

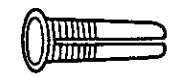

Dry Wall Anchors (2)

### Safety Reversing Sensor Installation Hardware

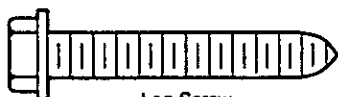

Lag Screw  
1/4"x1-1/2" (4)



Carriage Bolt  
1/4"-20x1/2" (4)



Lock Nut  
1/4"-20 (4)

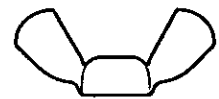

Wing Nut (2)



Hex Screw  
1/4"-20x1-1/2" (2)



Screw  
#10-32x3/8" (4)



Lock Nut  
#10x32 (4)



Insulated  
Staples (20)

# Assembly Section: Pages 7 – 10

To avoid installation difficulties, do not run the garage door opener until instructed to do so.

## Assembly Step 1 Assemble the Rail & Attach the Chain Pulley Bracket

- Align the 4 rail sections on a flat surface exactly as shown. Center sections are interchangeable. Front and back sections are not. Be sure the arrow labels are pointing toward the door.
- Insert the carriage bolts so the square bolt necks seat in the square holes in the rail sections and pass through the square holes in the opposing rail sections. Assemble lock nuts, ensure alignment and tighten.

If rail is not assembled exactly as shown, trolley will not travel smoothly along length of rail or it will hit against nuts.

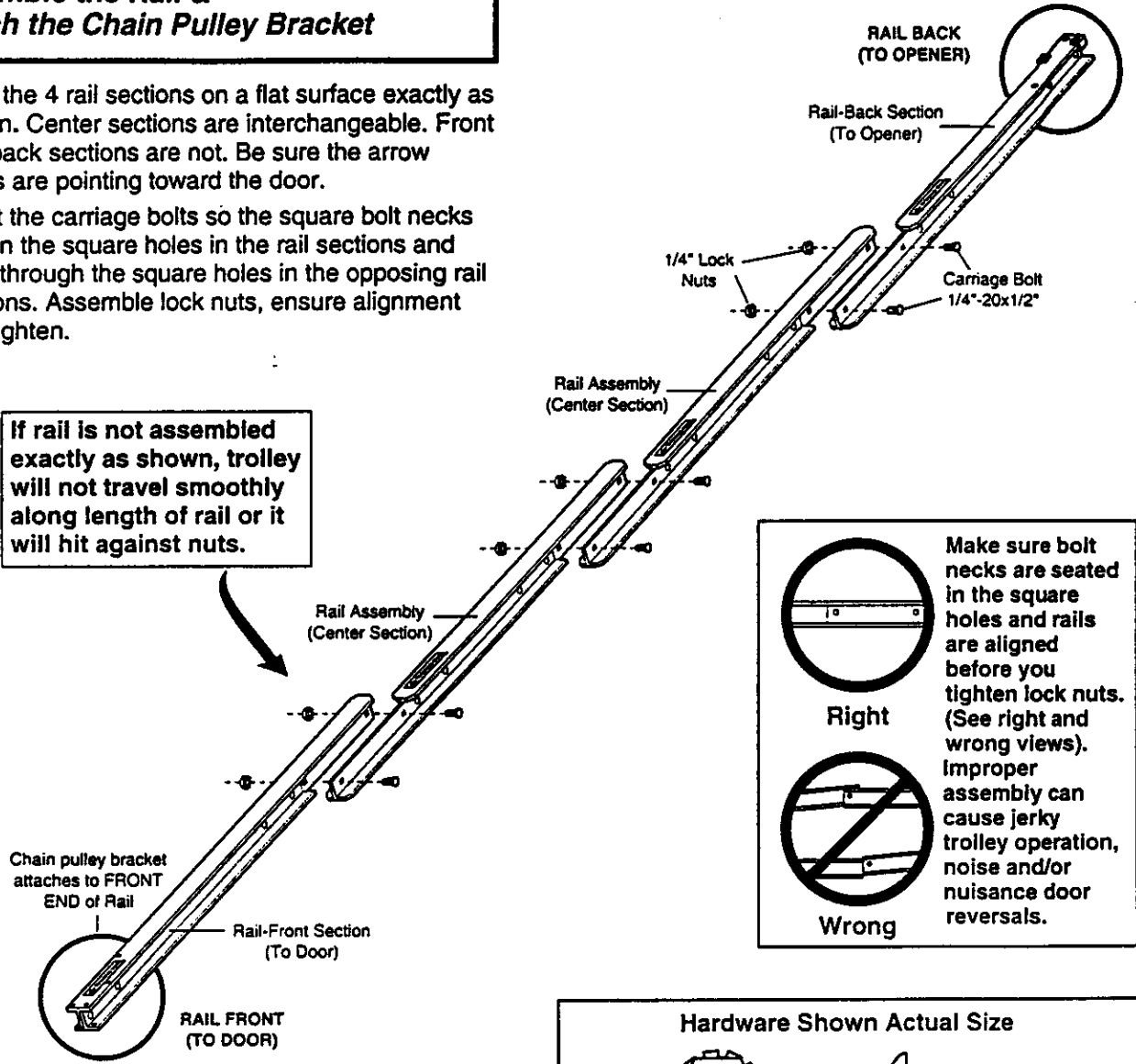

**Right**

**Wrong**

Make sure bolt necks are seated in the square holes and rails are aligned before you tighten lock nuts. (See right and wrong views). Improper assembly can cause jerky trolley operation, noise and/or nuisance door reversals.

- Position the chain pulley bracket on the front end of the rail as shown. Fasten securely with the hardware shown.

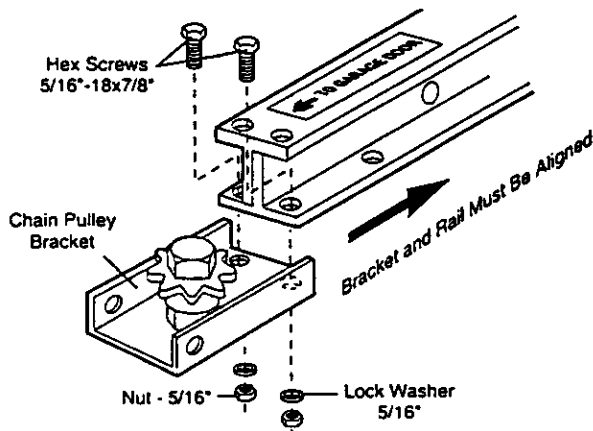

**Hardware Shown Actual Size**

Lock Nut 1/4"-20x7/16"

Carriage Bolt 1/4"-20x1/2"

Hex Screw 5/16"-18x7/8"

Nut 5/16"-18

Lock Washer 5/16"

**Right**

**Wrong**

When tightening the screws, be sure to keep bracket parallel to the rail. Otherwise, the rail may bow when the opener is operated.

## Assembly Step 2

### Install the Trolley on the Rail

- Attach the threaded shaft to the trolley with the lock washer and nuts as shown.

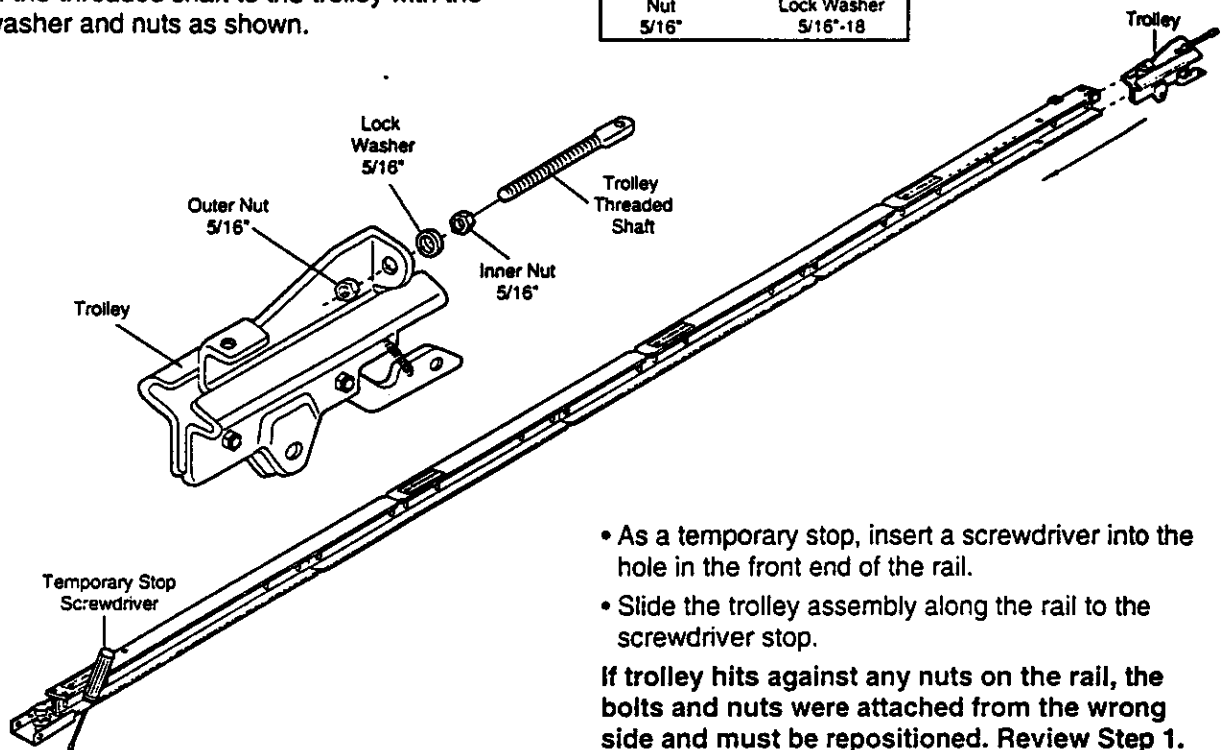
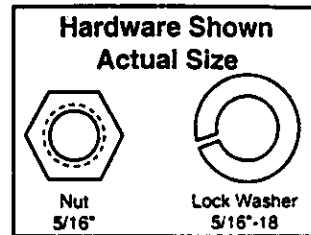

- As a temporary stop, insert a screwdriver into the hole in the front end of the rail.
- Slide the trolley assembly along the rail to the screwdriver stop.

If trolley hits against any nuts on the rail, the bolts and nuts were attached from the wrong side and must be repositioned. Review Step 1.

## Assembly Step 3

### Fasten the Rail to the Opener

- Place the opener on packing material to protect the cover. For convenience, put a support under the chain pulley bracket.
- Remove the (2) 5/16"-18x1/2" washered screws mounted in the top of the opener.
- Align the holes in the back section of the rail with the holes in the opener.
- Fasten the rail with the (2) washered screws previously removed. Tighten securely.

**Remember to use only these screws! Any other screws will cause serious damage to the opener.**

- Insert a 5/16"-18x7/8" hex screw into the cover protection bolt hole in the rail as shown. Tighten securely with a 5/16" lock washer and nut.

**NOTE: This screw prevents trolley over-travel. Keep a 2" minimum between the trolley and this screw when adjusting travel limits (see page 24).**

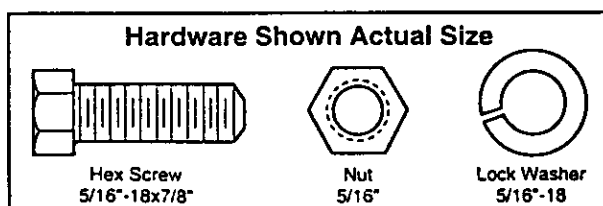
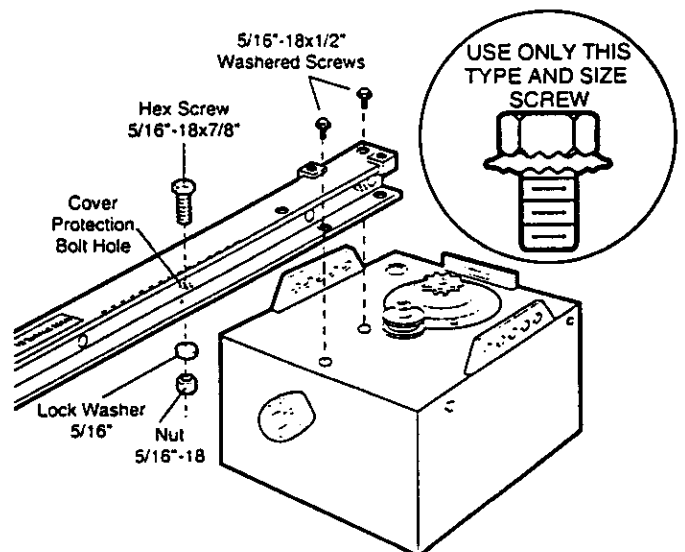
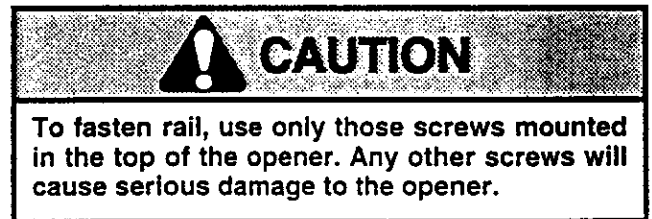



## Assembly Step 4

### Attach the Chain & Rail Support Bracket

- Remove the chain end from the carton and fasten it to the trolley with a master link from the hardware bag. See master link procedure, Figure 1.
- With the trolley against the screwdriver, dispense the chain around the pulley.
- Proceed back around the rail to the opener, Figure 2. Guide the chain around the chain spreader and sprocket. Be sure sprocket teeth engage the chain.
- Continue forward to the trolley threaded shaft, Figure 3.
- Use the second master link to connect the chain to the flat end of the shaft. If necessary, loosen the outer nut on the trolley to obtain more chain slack. **Check to make sure the chain is not twisted.**
- Remove the screwdriver.

Figure 1

#### Master Link Procedure:

Push pins of master link bar through chain end and hole in front end of trolley. Push cap over pins and past notches. Slide clip-on spring over cap and into notches until both pins are securely locked.

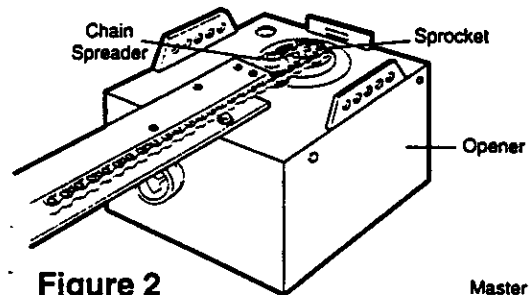
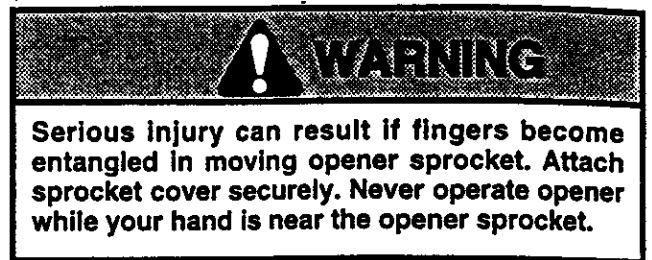
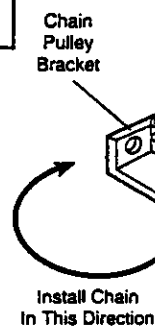

Figure 2

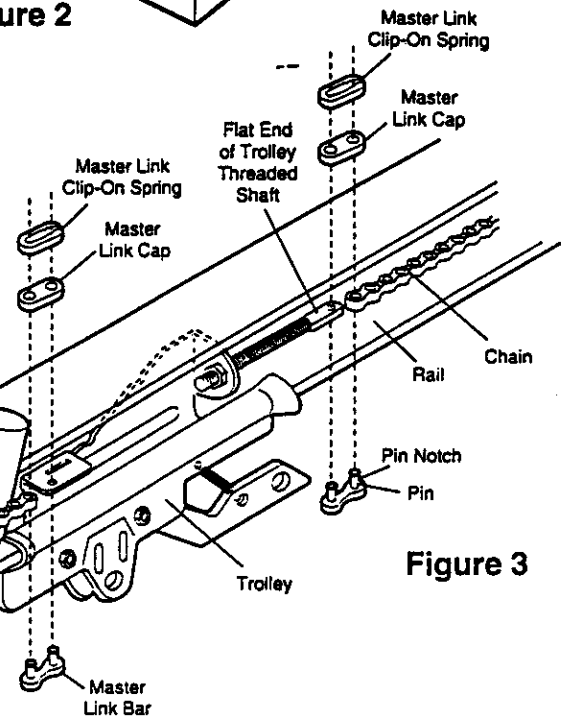
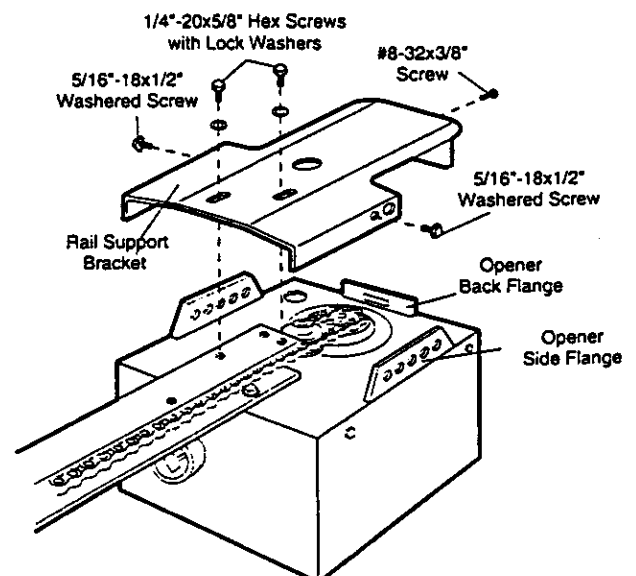

Figure 3

#### To attach the rail support bracket:

- Position the rail support bracket on the opener.
- Attach the bracket to the rail with 1/4"20x5/8" hex screws and lock washers.
- Attach the bracket to the opener by inserting a 5/16"-18x1/2" washered screw through a hole in each side flange and a matching hole in the bracket. Complete the connection by inserting the #8-32x3/8" screw through the back flange and the hole in the rail support.



#### Hardware Shown Actual Size

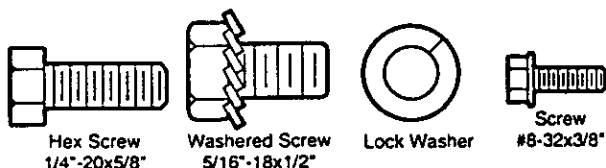

## Assembly Step 5

### Tighten the Chain

- Spin the inner nut and lock washer down the threaded shaft, away from the trolley.
- To tighten the chain, turn outer nut in the direction shown. As you turn the nut, keep the chain from twisting.
- When the chain is approximately 1/2" above the base of the rail at its midpoint, re-tighten the inner nut to secure the adjustment.

Sprocket noise can result if chain is either too loose or too tight.

When installation is complete, you may notice some chain droop with the door closed. This is normal. If the chain returns to the position shown when the door is open, *do not re-adjust the chain.*

**NOTE:** During future maintenance, **ALWAYS** pull the emergency release handle to disconnect trolley before adjusting chain.

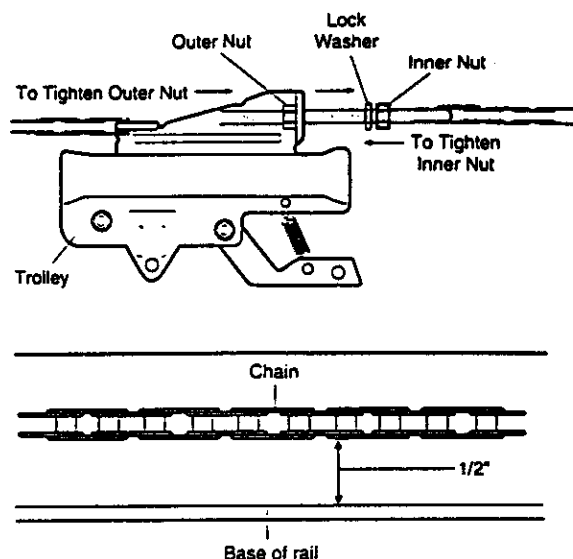

You have now finished assembling your garage door opener. Please read the following warnings before proceeding to the installation section:

## IMPORTANT INSTALLATION INSTRUCTIONS



**WARNING**



**WARNING**

**To reduce the risk of severe injury or death to persons:**

1. READ AND FOLLOW ALL INSTALLATION INSTRUCTIONS
2. Install only on a properly balanced and lubricated garage door. *An improperly balanced door may not reverse and could result in severe injury or death.* Repairs to cables, spring assemblies and other hardware must be made by a qualified service person before installing opener.
3. Disable all locks and remove all ropes connected to the garage door before installing the opener. *Ropes connected to a garage door can cause entanglement and death.*
4. If possible, install door opener 7 feet or more above floor with the emergency release handle mounted 6 feet above the floor.
5. Do not connect the opener to power source until instructed to do so.
6. Locate the Door Control within sight of the door at a minimum height of 5 feet where small children cannot reach and away from all moving parts of the door.
7. Install the User Safety Instruction Label on the wall adjacent to the control button and the Maintenance Instruction Label in a prominent location on the inside of the garage door.
8. Upon completion of the installation, the door must reverse when it comes in contact with a one-inch high object or a 2x4 laid flat on the floor.
9. Do not wear watches, rings or loose clothing while installing or servicing an opener. Jewelry or loose clothing can be caught in the mechanism of the garage door or the opener.

## Installation Step 1

### Determine Header Bracket Location

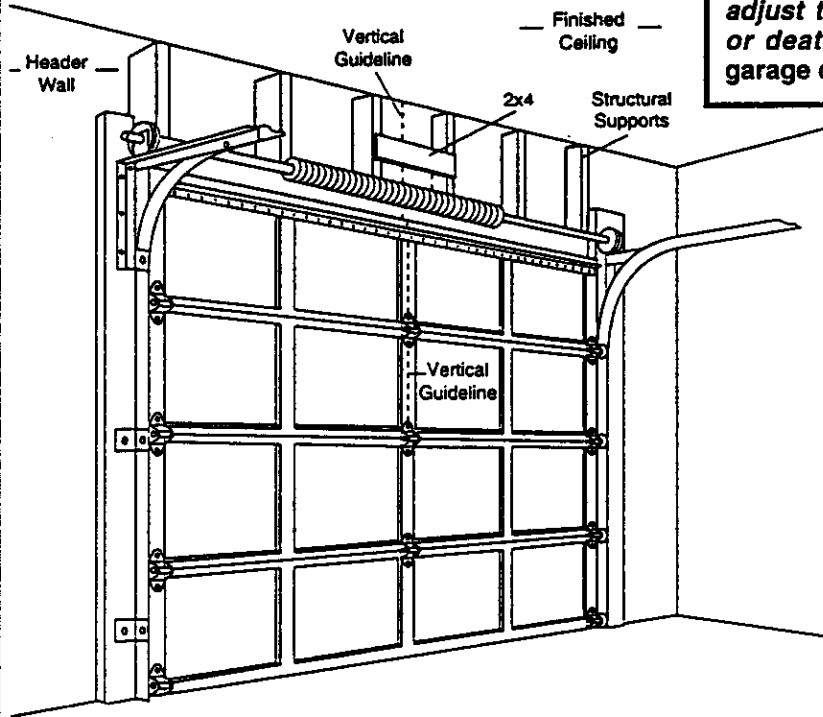

## WARNING

If the header bracket is not rigidly fastened to a structural support on the header wall or ceiling, the safety reverse system may not work properly (see page 26). *The door might not reverse when required, and could cause serious injury or death.*

The garage door springs, cables, pulleys, brackets and their hardware are under extreme tension. *Do not attempt to loosen, move or adjust them yourself. Serious personal injury or death could result. Call for professional garage door service.*

- Close the door and mark the inside vertical centerline of the garage door.
- Extend the line onto the header wall above the door.

Remember, you can fasten the header bracket within 2 feet to the left or right of the door center *only* if a torsion spring or center bearing plate is in the way; or you can attach it to the ceiling (refer to page 12) when clearance is minimal. (It may be mounted on the wall upside down if necessary, to gain approximately 1/2".)

*If you need to install the header bracket on a 2x4 (on wall or ceiling), use lag screws (not provided) to securely fasten the 2x4 to structural supports as shown here.*

- Open your door to the highest point of travel as shown. Draw an intersecting horizontal line on the header wall 2" above the high point. This height will provide travel clearance for the top edge of the door.

Door clearance brackets are available when headroom clearance is less than 2". See accessory page 34.

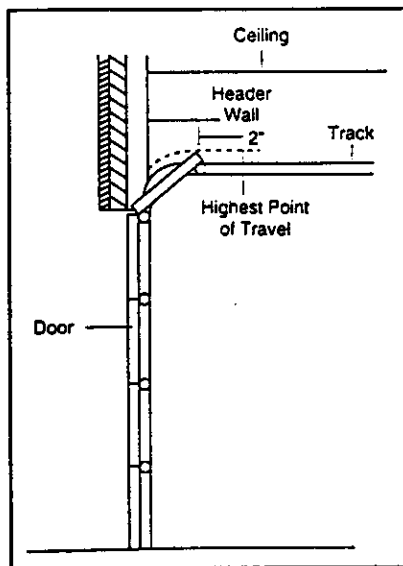

Proceed to Step 2, page 12.

## Installation Step 2

### Install the Header Bracket

You can attach the header bracket either to the wall above the garage door, or to the ceiling. Follow the instructions which will work best for your particular requirements.

#### Fasten the Header Bracket to the Wall

- Center the bracket on the vertical guideline with the bottom edge of the bracket on the horizontal line as shown (with the arrow pointing toward the ceiling).

- Mark either set of bracket holes (do not use the holes designated for ceiling mount). Drill  $3/16"$  pilot holes and fasten the bracket securely to a structural support with the hardware provided.

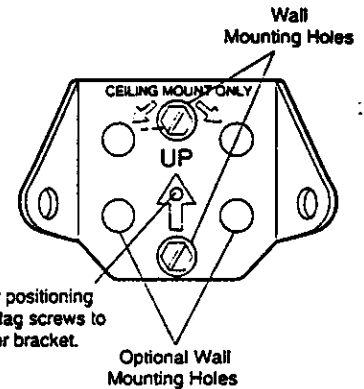
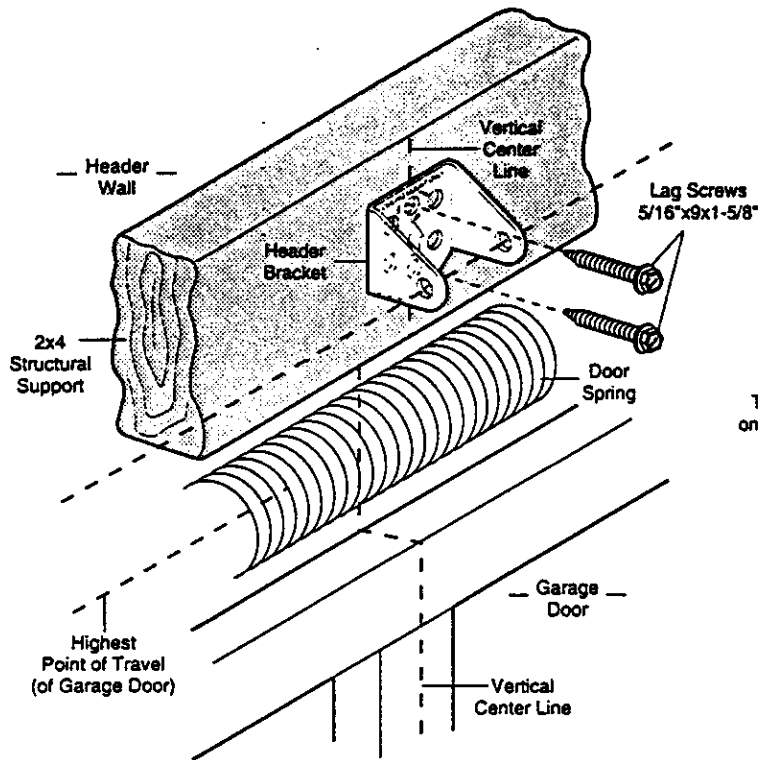

#### Hardware Shown Actual Size



#### Fasten the Header Bracket to the Ceiling

- Extend the vertical guideline onto the ceiling as shown.
- Center the bracket on the vertical mark, no more than 6" from the wall. Make sure the arrow is pointing toward the wall. The bracket can be mounted flush against the ceiling when clearance is minimal.
- Mark holes designated for ceiling mount only. Drill  $3/16"$  pilot holes and fasten the bracket securely to a structural support with the hardware provided.

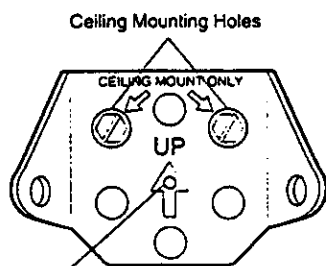

The nail hole is for positioning only. You must use lag screws to mount the header bracket.

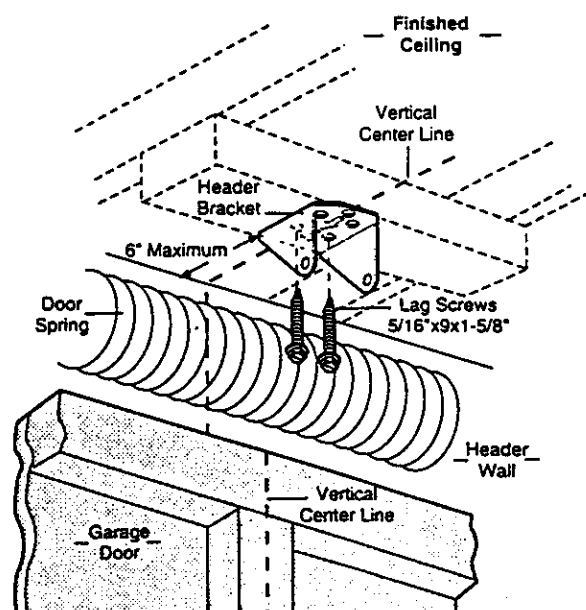

## Installation Step 3

### Attach the Rail to the Header Bracket

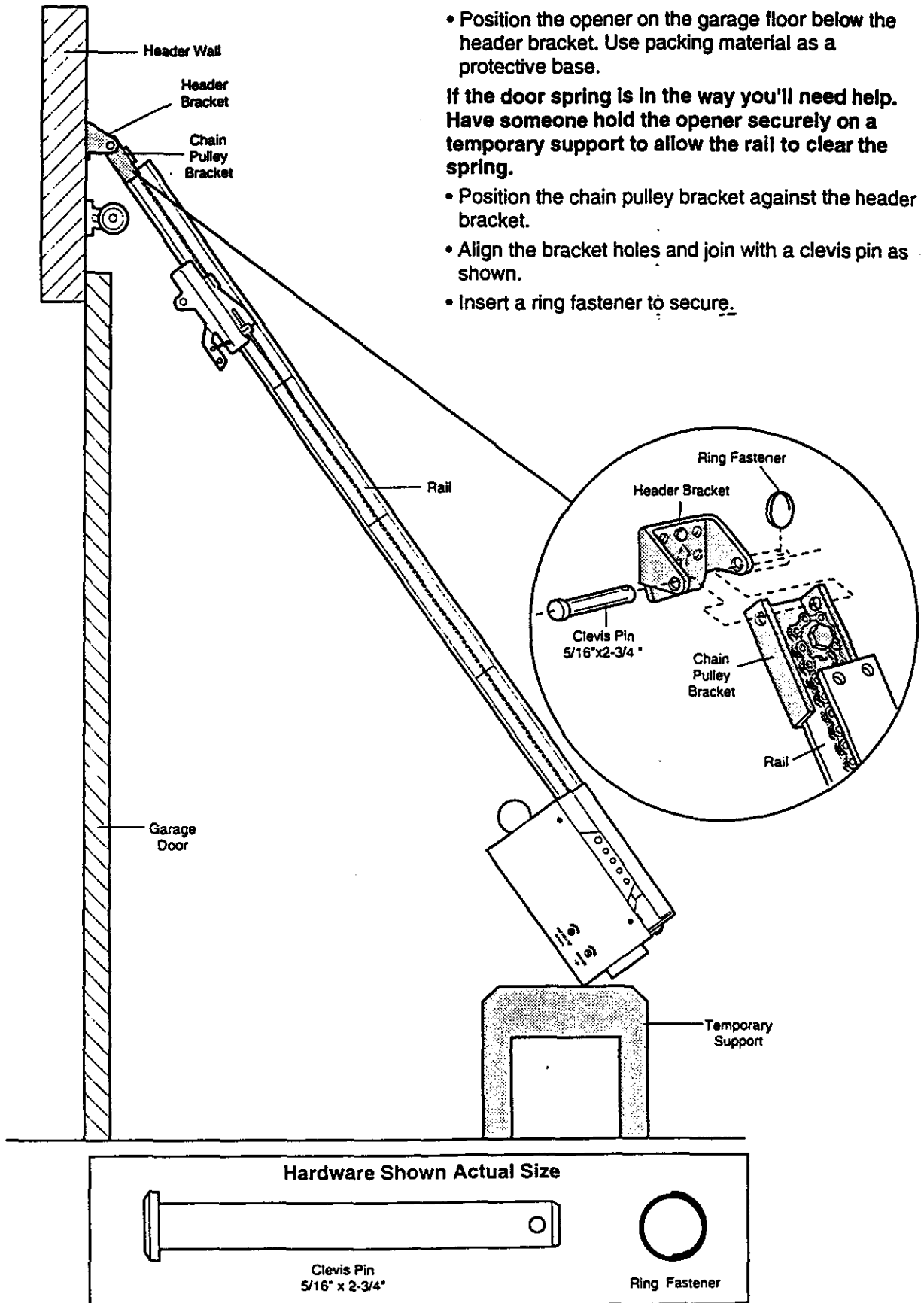

## Installation Step 4

### Position the Opener



**CAUTION**

To prevent damage to steel, aluminum, fiberglass or glass panel doors, do not rest the opener on the door without using a 2x4.

A 2x4 laid flat is convenient for setting an ideal door-to-rail distance.

- Raise the opener onto a stepladder.

*You will need help at this point if the ladder is not tall enough.*

- Open the door all the way and place a 2x4 laid flat on the top section beneath the rail.

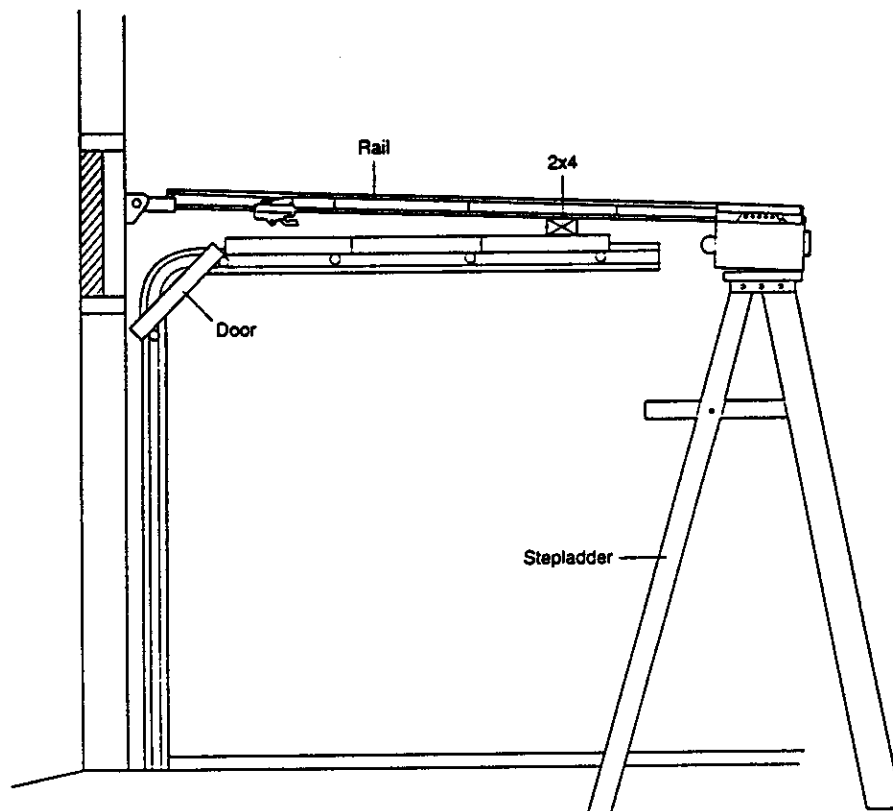

- If the top panel hits the trolley when you raise the door, pull down on the trolley release arm to disconnect the inner and outer sections. The trolley can remain disconnected until Step 12 is completed.

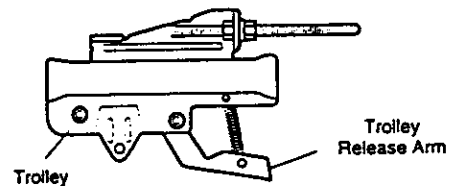

## Installation Step 5

### Hang the Opener

Two representative installations are shown. Yours may be different. Hanging brackets should be angled, Figure 1, to provide rigid support. On finished ceilings, Figure 2, attach a sturdy metal bracket to structural supports in ceiling before installing the opener. The bracket and fastening hardware are not provided. See accessory page 34.

- Measure the distance from *each* side of the opener to the structural support.
- Cut both pieces of the hanging bracket to required lengths.
- Drill  $3/16"$  pilot holes in the structural supports.
- Attach one end of each bracket to a support with  $5/16"$ - $18 \times 1-5/8"$  lag screws.
- Fasten the opener to the hanging brackets with  $5/16"$ - $18 \times 7/8"$  hex screws, lock washers and nuts.
- Check to make sure the rail is centered over the door (or in line with the header bracket if the bracket is not centered above the door).
- Remove the 2x4. Operate the door manually. If the door hits the rail, raise the header bracket.

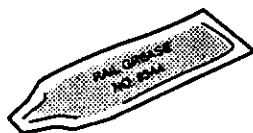

Grease the top and underside of the rail surface where the trolley slides. A tube of grease is supplied.

#### Hardware Shown Actual Size



Lag Screw  
 $5/16"$ - $9 \times 1-5/8"$



Hex Screw  
 $5/16"$ - $18 \times 7/8"$



Nut  $5/16"$ -18



Lock Washer  $5/16"$



## WARNING

The opener could fall and injure someone if it is not properly secured. Fasten the opener securely to structural supports of the garage.

Figure 1

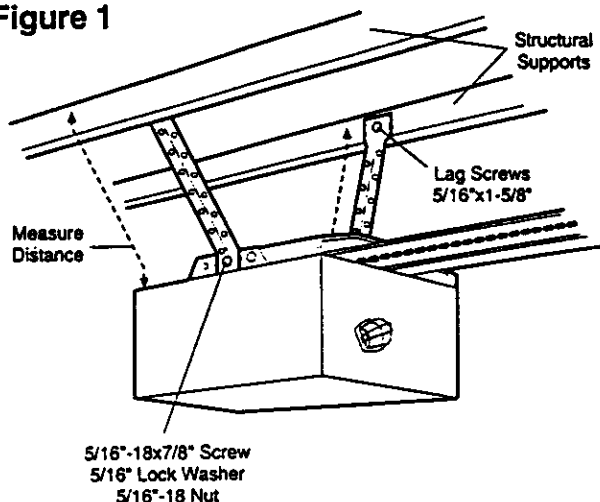
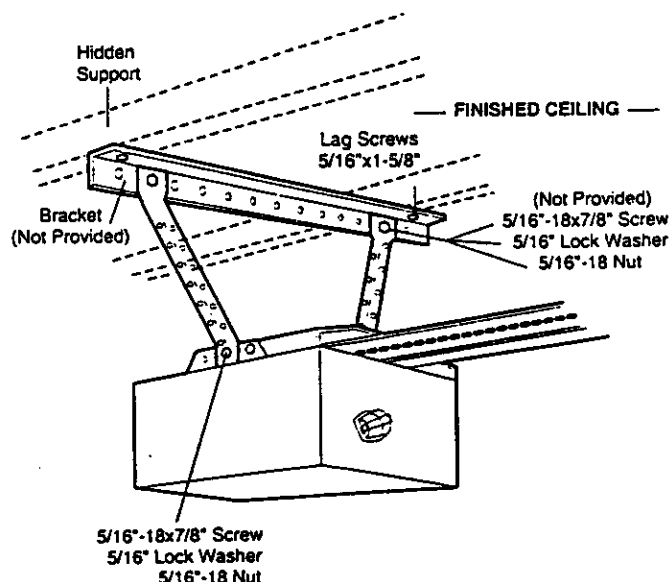

Figure 2



## Installation Step 6

### Install the Door Control

Locate the Door Control within sight of the door at a minimum height of 5 feet where small children cannot reach, and away from all moving parts of the door and door hardware.

The door control is typically attached directly to the wall. If installing into drywall, drill 5/32" holes and use the anchors provided.

- Strip 1/4" of insulation from one end of the bell wire; connect the wire to the two screw terminals on the back of the Door Control: white to 2, and white/red to 1.
- Fasten the Door Control securely with 6ABx1-1/2" screws.
- Run the bell wire up the wall and across the ceiling to the opener. Use insulated staples to secure the wire in several places. Be careful not to pierce the wire with a staple, thereby resulting in a short.
- Receiver terminal screws and the antenna are located on the back panel of the opener. Position the antenna wire as shown.
- Then connect the bell wire to the opener terminal screws: white to 2 and white/red to 1.
- Remember to affix the User Safety Instruction label to the wall near the Door Control, and the Maintenance Instruction Label in a prominent location on the inside of the garage door.

If the label adhesive will not adhere to your garage wall surface (or becomes loose with time), use tacks to secure the label alongside the Door Control.

Page 29 explains how to operate the opener using the door control.

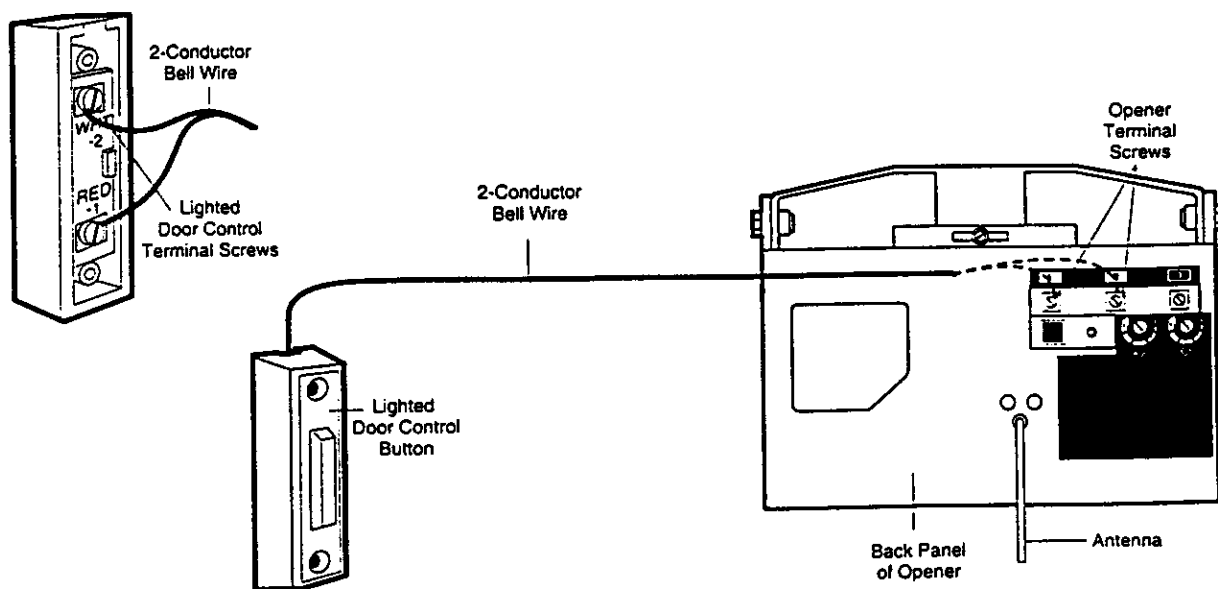

## WARNING

Children operating or playing with a garage door opener can injure themselves or others. *The garage door could close and cause serious injury or death.*

Install the Door Control (or any additional push buttons) out of the reach of children and away from all moving parts of the door and door hardware, *but where the garage door is visible.* Do not allow children to operate the push button or the remote controls.

*A moving garage door could injure someone under it.* Activate the opener only when the door is properly adjusted, you can see it clearly, and there are no obstructions to door travel.

**Do NOT connect the power and operate the opener at this time.** The trolley will travel to the full open position but will not return to the close position until the sensor beam is connected and properly aligned.

See Safety Reversing Sensor Instructions beginning on page 19.

### Hardware Shown Actual Size

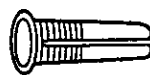

Dry Wall Anchors

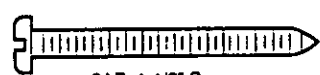

6ABx1-1/2" Screw  
Door Control Button



Insulated  
Staples



## Installation Step 7

### Install the Light

- Install a 75 watt maximum light bulb in the socket. The light will turn ON and remain lit for approximately 4-1/2 minutes when power is connected. Then the light will turn OFF.
- If the bulb burns out prematurely due to vibration, replace with a *standard neck "Garage Door Opener"* bulb.

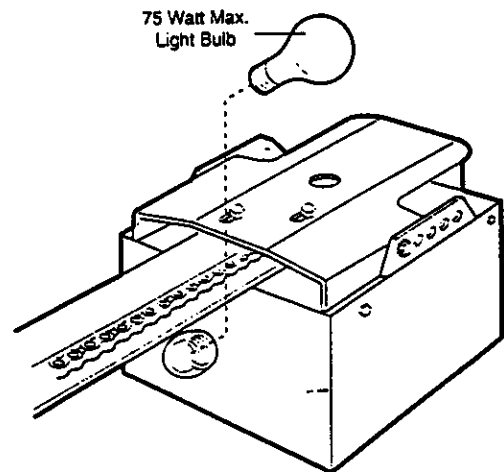

## Installation Step 8

### Attach the Emergency Release Rope and Handle

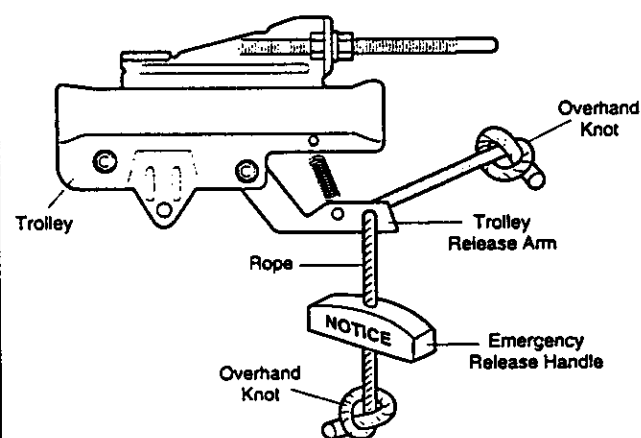

## WARNING

Do not use the red handle to pull the door open or closed. *The rope knot could become untied and you could fall.* Use the emergency release only to disengage the trolley and, if possible, only when the door is closed.

Garage doors are heavy. If the door is open when the handle is pulled, the door could close inadvertently if it is not properly balanced. Serious injury may result to persons under the door. Make sure the doorway is clear of persons and obstructions before pulling handle when door is open.

- Thread one end of the rope through the hole in the top of the red handle so "NOTICE" reads right side up as shown. Secure with an overhand knot. The knot should be at least 1" from the end of the rope to prevent slipping.
  - Thread the other end of the rope through the hole in the release arm of the outer trolley.
  - Adjust rope length so the handle is 6 feet above the floor. Secure with an overhand knot.
- If it is necessary to cut the rope, heat seal the cut end with a match or lighter to prevent unraveling.

## Installation Step 9

### Electrical Requirements

To reduce the risk of electric shock, your garage door opener has a grounding type plug with a third grounding pin. This plug will *only* fit into a grounding type outlet.

If the plug doesn't fit into the outlet you have, contact a qualified electrician to install the proper outlet.

*To avoid installation difficulties, do not run the opener at this time.*



## WARNING

To prevent electrocution or fire, installation and wiring must be in compliance with local electrical and building codes.

Do **NOT** use an extension cord, 2-wire adapter, or change the plug in any way to make it fit your outlet.

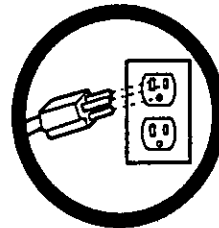

Right

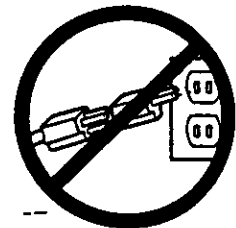

Wrong

If permanent wiring is required by your local code, refer to the following procedure:



## WARNING

To prevent electrocution, remove power from the garage door opener *and* from the circuit you plan to use for the permanent connection.

To make a permanent connection through the 7/8" diameter hole in the top of the opener (according to local code):

- Remove the opener cover screws and set the cover aside.
- Remove the attached 3-prong cord.
- Connect the black (line) wire to the screw on the brass terminal; the white (neutral) wire to the screw on the silver terminal; and the ground wire to the green ground screw. *The opener must be grounded.*
- Reinstall the cover.

*To avoid installation difficulties, do not run the opener at this time.*

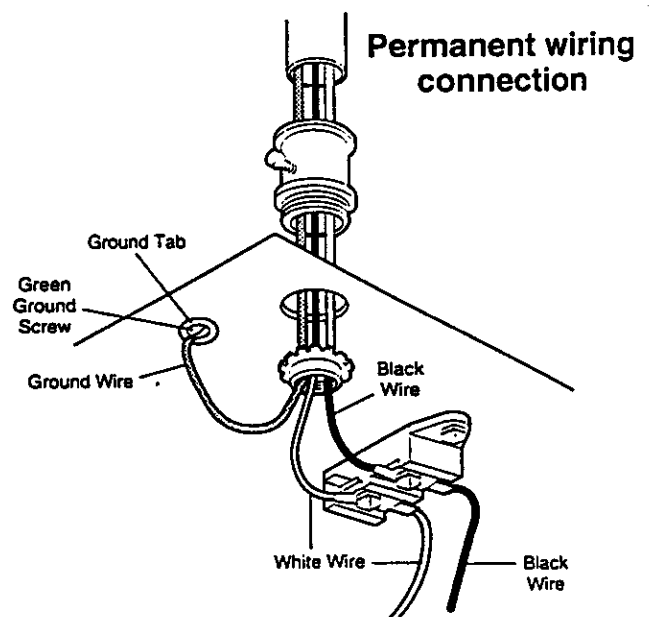

# Safety Reversing System

Information you'll need before you begin the installation of the safety reversing sensor.

The safety reversing sensor *must* be connected and aligned correctly before the garage door opener will move in the down direction. This is a required safety device and cannot be disabled.

 **WARNING**

*Without a properly working safety reversing sensor, persons (particularly children) could be killed by a closing garage door. Read and follow all instructions.*

**To protect small children, install the safety reversing sensor so that the beam will be no higher than 4-6" above the garage floor.**

**Disconnect power to the garage door opener before installing the safety reversing sensor.**

## Be sure power to the opener is disconnected.

The sending eye transmits an invisible light beam to the receiving eye. The units can be installed on either side of the garage door as long as the sun never shines directly into the receiving eye lens.

Look at the label on the connector end of each case to identify the sensors.

The brackets must be connected and fastened so that the sending and receiving eyes face each other as shown below in Figure 1.

If an obstruction breaks the light beam while the garage door is closing, the door will stop and reverse to full open position and the opener light will flash for 5 seconds.

The brackets *must* be securely fastened to a solid surface such as the studs on either side of the door, or add a piece of wood at each location if installing in masonry construction.

The invisible light beam path must be unobstructed. No part of the garage door (or door tracks, springs, hinges, rollers or other hardware) can interrupt the beam while the door is closing. If it does, use a piece of wood to build out each sensor mounting location to the minimum depth required for light beam clearance.

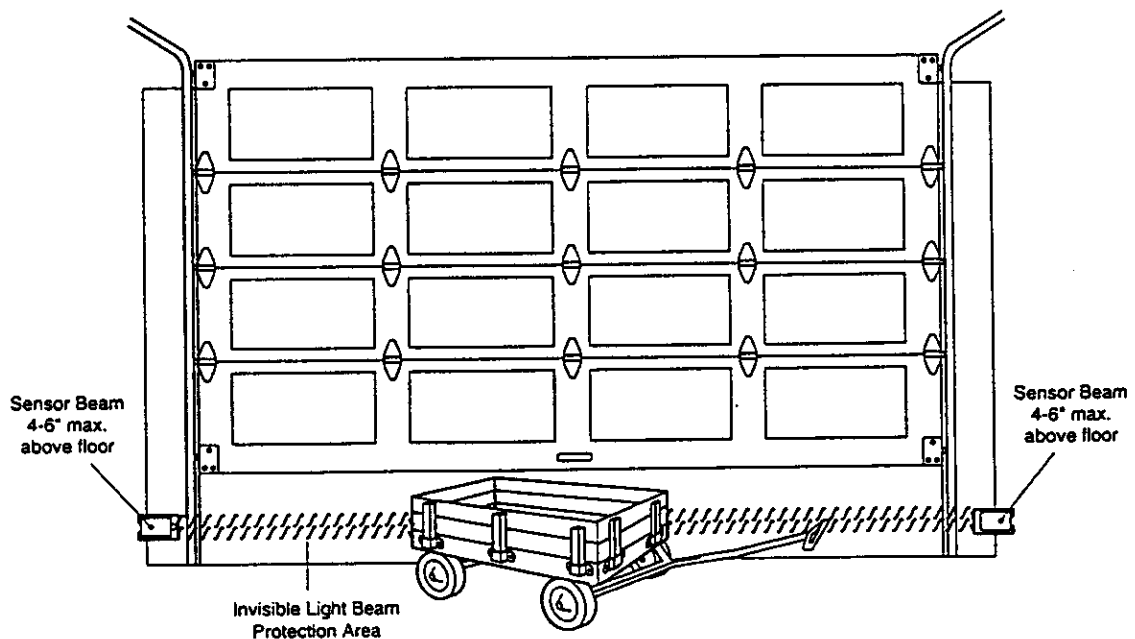

Figure 1: Facing the door from inside the garage

# Installation Step 10

## Install the Safety Reversing Sensor

Figures 2 and 3 show assembly of brackets and "C" wrap based on the recommended installation of the sensors as shown on page 19.

However, Figures 4 and 5 are variations which may fit your installation requirements better. **Make sure the wraps and brackets are aligned so the sensors will face each other across the garage door.**

- Fasten the "C" wraps to the mounting brackets having square holes, using the hardware shown in Figure 2.
- Connect each assembly to a slotted bracket, using the hardware shown in Figure 3.

**Note the alignment of the brackets for left and right sides of the door.**

- Finger tighten the lock nuts.
- Use bracket mounting holes as a template to locate and drill (2) 3/16" diameter pilot holes on both sides of the garage door, 4"-6" above the floor *but not exceeding 6"*. (See warning on page 19.)
- Attach bracket assemblies with 1/4"x1-1/2" lag screws as shown in Figure 3.
- Adjust right and left side bracket assemblies to the same distance out from mounting surface. Make sure all door hardware obstructions are cleared. Tighten the nuts securely.

Figure 2

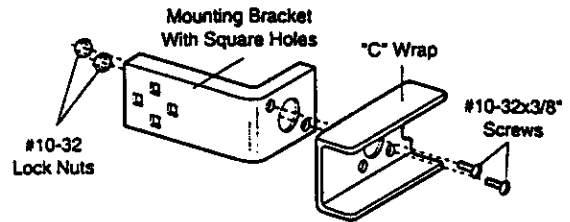

Figure 3

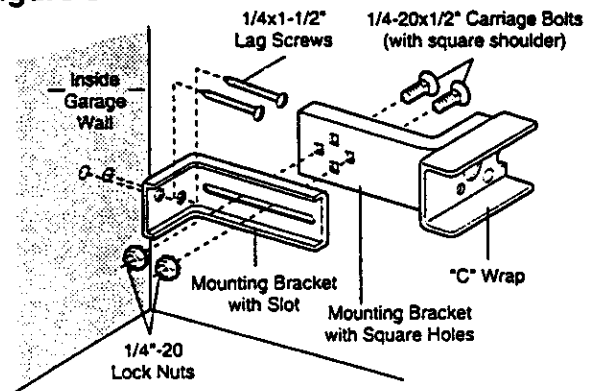

Figure 4

Alternate Wall Mount

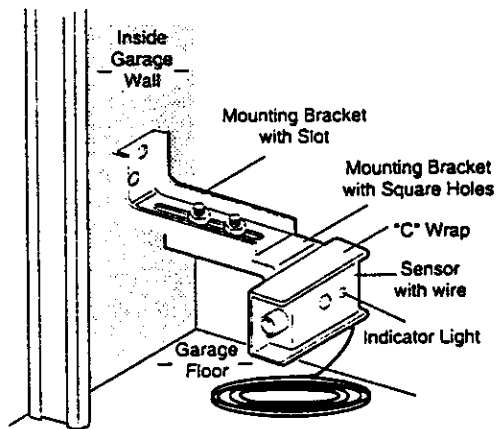
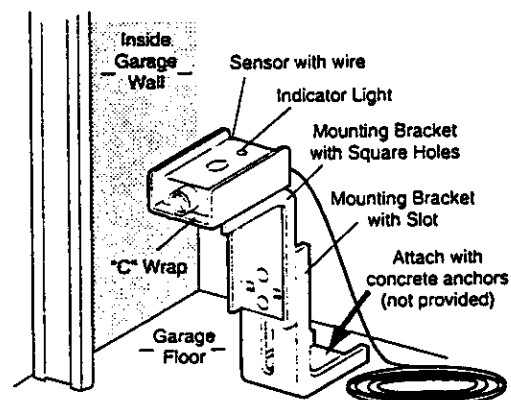

Figure 5

Alternate Floor Mount



### Hardware Shown Actual Size



Screw  
#10-32x3/8"



Lock Nut  
#10x32



Lag Screw  
1/4x1-1/2"



Insulated Staples



Carriage Bolt  
1/4"-20x1/2"



Lock Nut  
1/4"-20

- Center each sensor unit in a "C" wrap with lenses pointing toward each other across the door (see Figure 6).
- Secure sensors with the hardware shown. Finger tighten the wing nut on the *receiving eye* to allow for final adjustment. Securely tighten the *sending eye* wing nut.
- Run the wires from both sensors to the opener. Use insulated staples to secure wire to wall and ceiling.
- Strip 1/4" of insulation from each set of wires. Separate white and white/black wires sufficiently to connect to the opener terminal screws: white to 2 and white/black to 3.

#### Aligning the Safety Sensors

- Plug in the opener. Green indicator lights in both the sending and receiving eyes will *glow steadily* if wiring connections and alignment are correct.

The *sending eye* indicator light will glow regardless of alignment or obstruction. If the indicator light is off, dim or flickering in the *receiving eye* (and the invisible light beam path is not obstructed), alignment is required.

- Loosen the *sending eye* wing nut and re-adjust, aiming directly at the receiving eye. Lock in place.
- Loosen the *receiving eye* wing nut and adjust sensor vertically and/or horizontally until it receives the sender's beam. When the green indicator light *glows steadily*, tighten the wing nut.

Figure 6

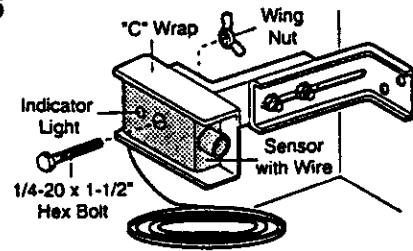

#### Trouble Shooting

1. If the *sending eye* indicator light does not *glow steadily* after installation, check for:
  - Electric power to the opener.
  - A short in the white or white/black wires. These can occur under staples or at screw terminal connections.
  - Incorrect wiring between sensors and opener.
  - An open wire (wire break). --
2. If the *sending eye* indicator light *glows steadily* but the *receiving eye* indicator light doesn't:
  - Check alignment.
  - Check for an open wire to the receiving eye.
3. If the *receiving eye* indicator light is dim, realign either sensor.

**NOTE:** When the invisible beam path is obstructed or misaligned while the door is closing, the door will reverse. If the door is already open, it will not close. The opener light will flash 10 times. (If bulb is not installed, 10 clicks are audible.) See page 19.

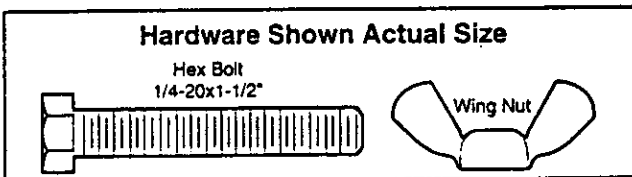
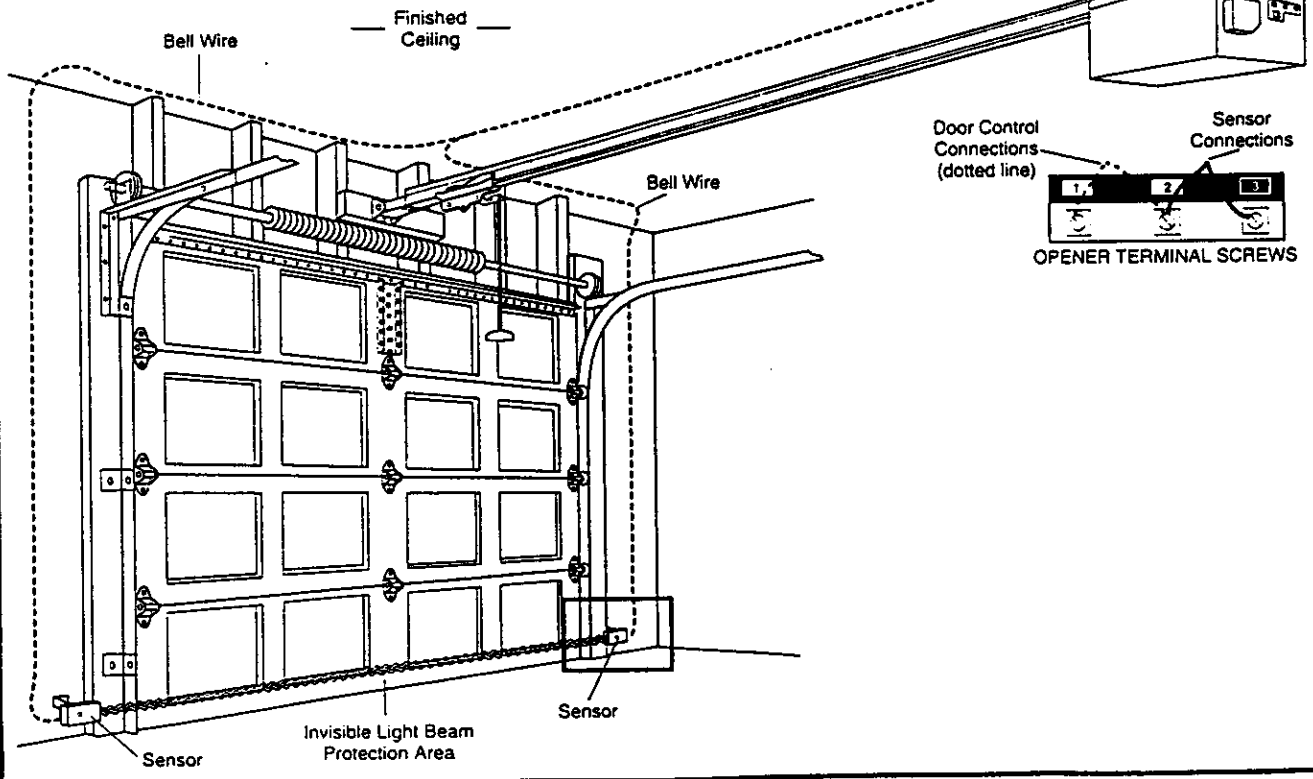

Figure 7



# Installation Step 11

## Fasten Door Bracket



# CAUTION

To prevent damage to steel, aluminum, fiberglass or glass panel doors, always reinforce the inside of the door both vertically and horizontally with an angle iron.

A horizontal brace should be long enough to be secured to 2 vertical supports. A vertical brace should cover the height of the top panel.

The illustration shows one piece of angle iron as the horizontal brace. For the vertical brace, 2 pieces of angle iron are used to create a "U"-shaped support. The best solution is to check with your garage door manufacturer for an opener installation, door reinforcement kit.

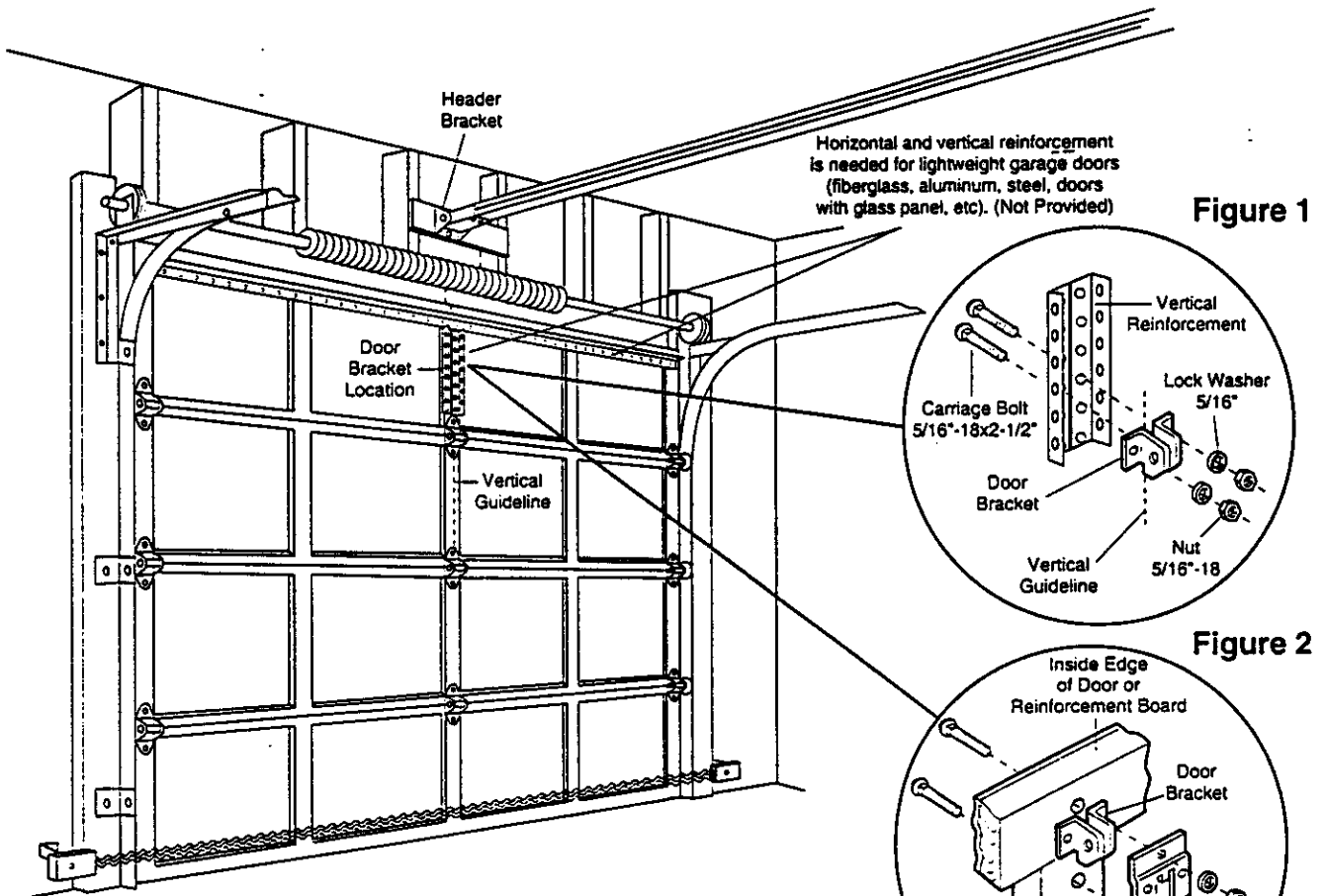

Figure 1

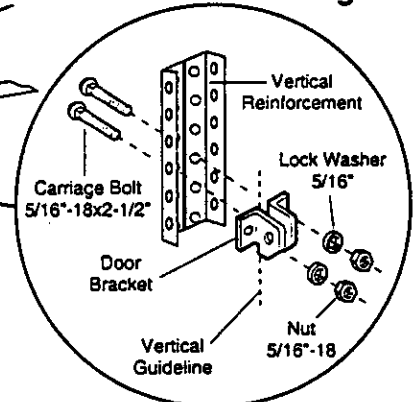
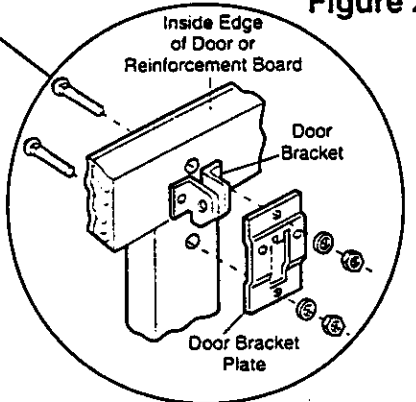
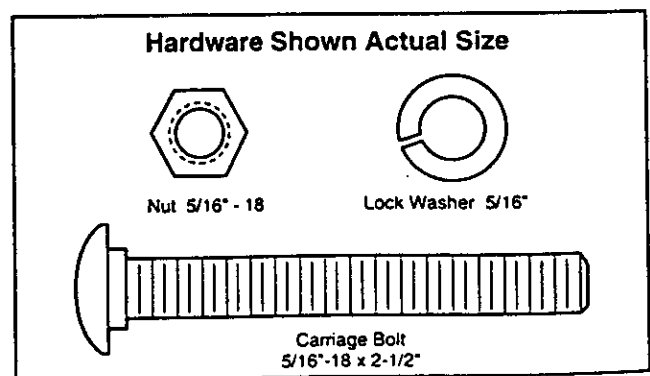

Figure 2



- Center the door bracket on the previously marked vertical guideline used for the header bracket installation.
- Position the bracket on the face of the door within the following limits:
  - A) The top edge of the bracket 2"-4" below the top edge of the door.
  - B) The top edge of the bracket directly below any structural support across the top of the door.
- Mark and drill 5/16" left and right fastening holes. Secure the bracket as shown in Figure 1 if there is vertical reinforcement.

If your installation doesn't require vertical reinforcement but does need top and bottom fastening holes for the door bracket, position the door plate over the door bracket as shown in Figure 2.



# Installation Step 12

## Connect Door Arm to Trolley

Make sure garage door is fully closed. Pull the emergency release handle to disconnect the outer trolley from the inner trolley. Slide the outer trolley back (away from the door) about 2" as shown in Figures 1, 2 and 3.

Figure 1:

- Fasten straight door arm section to outer trolley with a clevis pin. Secure the connection with a ring fastener.
- Fasten curved section to the door bracket in the same way.

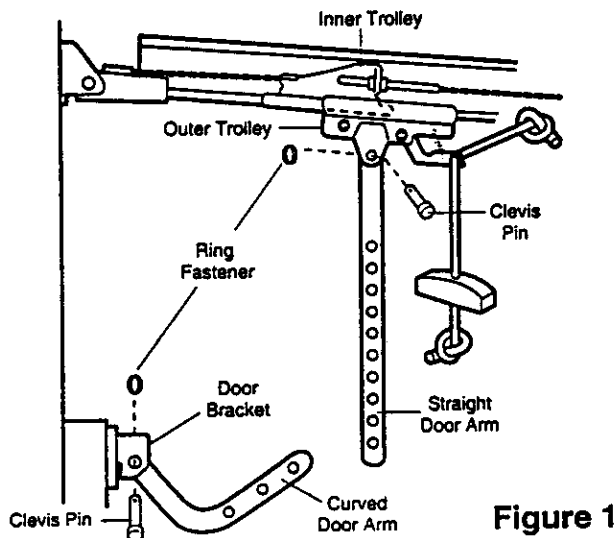

Figure 1

Figure 2:

- Bring arm sections together. Find two pairs of holes that line up and join sections. Select holes as far apart as possible to increase door arm rigidity.

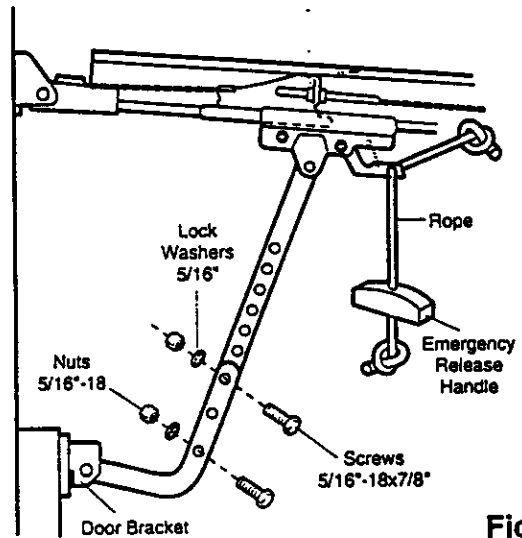

Figure 2

### Hole Alignment Alternative

Figure 3:

- If holes in curved arm are *above* holes in straight arm, disconnect straight arm. Cut about 6" from the solid end. Reconnect to trolley with *cut end down* as shown.
- Bring arm sections together.
- Find two pairs of holes that line up and join with screws, lock washers and nuts.

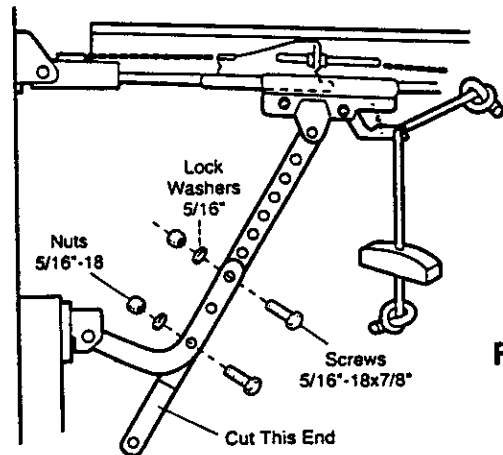

Figure 3

#### Hardware Shown Actual Size



Nut 5/16"-18



Lockwasher 5/16"



Ring Fastener

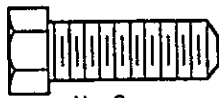

Hex Screw 5/16"-18x7/8"

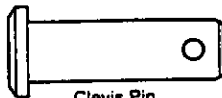

Clevis Pin 5/16" x 1"

Proceed to Adjustment Step 1, page 24. Trolley will re-engage automatically when the opener is operated.

## Adjustment Step 1

### Adjust the UP and DOWN Limits

*Do not make any limit adjustments until the safety reversing sensors are completely installed.*

Limit adjustment settings regulate the points at which the door will *stop* when moving up or down.

The door will *stop* in the *up* direction if anything interferes with door travel. The door will *reverse* in the *down* direction if anything interferes with the door travel (including binding or unbalanced doors)

To operate the opener, press the Door Control button. Run the opener through a complete travel cycle.

- Does the door open and close completely?
- Does the door stay closed and not reverse unintentionally when fully closed?

If your door passes both of these tests, no limit adjustments are necessary unless the reversing test fails (see page 26).

Adjustment procedures are outlined below. **Run the opener through a complete travel cycle after each adjustment.**

*Repeated operation of the opener during adjustment procedures may cause the motor to overheat and shut off. Simply wait 15 minutes and try again.*

Read the procedures carefully before continuing on to Adjustment Step 2. Use a screwdriver to make limit adjustments.

WARNING

Improper adjustment of the travel limits could interfere with the proper operation of the safety reverse system. *The door might not reverse properly when required and could seriously injure or kill someone under it. Test the safety reverse system following all adjustments to the travel limits. See page 26.*

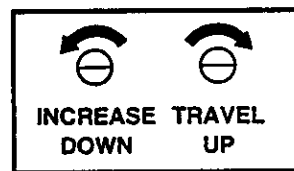
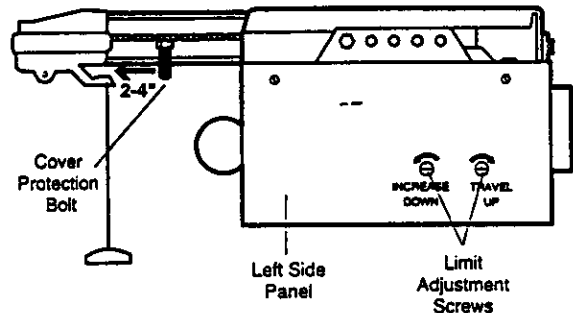

Adjustment Label

## How and When to Adjust the Limits

- **If the door does not open completely but opens at least five feet:**

Increase *up* travel. Turn the UP limit adjustment screw clockwise. One turn equals 2" of travel.

**NOTE:** *To prevent the trolley from hitting the cover protection bolt, keep a minimum distance of 2-4" between the trolley and the bolt.*

- **If door does not open at least 5 feet:**

Adjust the UP (open) force as explained in Adjustment Step 2.

- **If the door does not close completely:**

Increase *down* travel. Turn the DOWN limit adjustment screw counterclockwise. One turn equals 2" of travel.

If door still won't close completely and the trolley bumps into the pulley bracket (see page 4), try lengthening the door arm. (See page 23.)

If you have adjusted the door arm to the maximum length and the door still will not close completely, lower the header bracket. See Installation Steps 1 and 2, pages 11 and 12.

- **If the opener reverses in fully closed position:**

Decrease *down* travel. Turn the DOWN limit adjustment screw clockwise. One turn equals 2" of travel.

- **If the door reverses when closing and there is no visible interference to travel cycle:**

If the opener light is flashing, the Safety Reversing Sensors are either not installed, misaligned, or obstructed. See Troubleshooting, page 21.

Test the door for binding: Pull the emergency release handle. Manually open and close the door. If the door is binding, call for garage door service. If the door is not binding or unbalanced, adjust the DOWN (close) force. See Adjustment Step 2.



## Adjustment Step 2

### Adjust the Force

Force adjustment controls are located on the back panel of the opener. Force adjustment settings regulate the amount of power required to open and close the door.

The door will *stop* in the *up* direction if anything interferes with its travel. The door will *reverse* in the *down* direction if anything interferes with its travel (including binding or unbalanced doors).

If the forces are set too light, door travel may be interrupted by *nuisance reversals* in the *down* direction and *stops* in the *up* direction. Weather conditions can affect the door movement, so occasional adjustment may be needed.

The maximum force adjustment range is 260 degrees, about 3/4 of a complete turn. Do not force controls beyond that point. Turn force adjustment controls with a screwdriver.

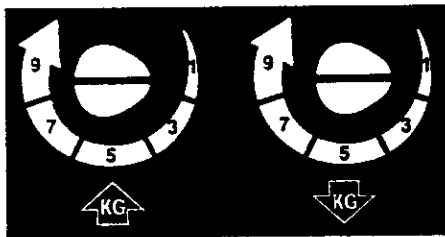

Adjustment Label

**! WARNING**

Too much force on the door will interfere with the proper operation of the safety reverse system. *The door might not reverse properly when required and could seriously injure or kill someone under it.* Do not increase the force beyond the minimum required to close the door. Do not use the force adjustments to compensate for a binding or sticking garage door. Test the safety reverse system following all adjustments to force levels. See page 26.

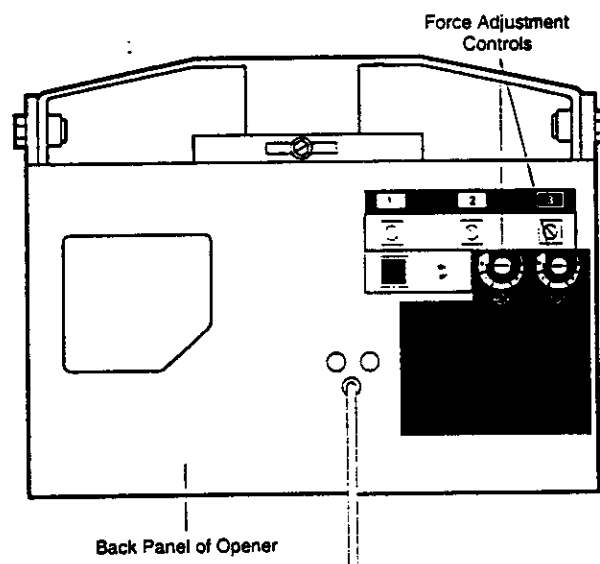

## How and When to Adjust the Forces

### Test the DOWN (close) force:

Grasp the door bottom when the door is about halfway through DOWN (close) travel. The door should reverse. **Reversal halfway through down travel does not guarantee reversal on a one-inch obstruction.** See page 26. If the door is hard to hold or doesn't reverse, decrease the DOWN (close) force by turning the control counterclockwise.

Make 10 degree turn adjustments until the door reverses normally. After each adjustment, run the opener through a complete cycle.

### Test the UP (open) force:

Grasp the door bottom when the door is about halfway through UP (open) travel. The door should stop. If the door is hard to hold or doesn't stop, decrease UP (open) force by turning the control counterclockwise.

Make 10 degree turn adjustments until the door stops easily. After each adjustment, run the opener through a complete travel cycle.

### If the door doesn't open at least 5 feet:

Increase UP (Open) force by turning the control clockwise. Make 10 degree turn adjustments until door opens completely. Re-adjust the UP limit if necessary. After each adjustment, run the opener through a complete travel cycle.

### If the door reverses during the down (close) cycle and the opener light isn't flashing:

Increase DOWN (close) force by turning the control clockwise. Make 10 degree turn adjustments until the door completes a close cycle. After each adjustment, run the opener through a complete travel cycle. **Do not increase the force beyond the minimum amount required to close the door.**

## Adjustment Step 3

### Test The Safety Reversing Sensor

- Press the Door Control button to open the door.
- Place the opener carton in the path of the door.
- Press the Door Control button to close the door.  
*The door will not move more than an inch, and the opener light will flash.*

**Professional service is required if the opener closes the door when the safety reversing sensor is obstructed.**

The garage door opener will not close from a remote if the indicator light in either sensor is **off**, alerting you to the fact that the sensor is misaligned or obstructed.

The garage door can be closed by pressing and holding the Door Control button until down travel is completed.

 **WARNING**

*Without a properly working safety reversing sensor, persons (particularly children) could be seriously injured or killed if trapped by a closing garage door. Repeat this test once a month.*

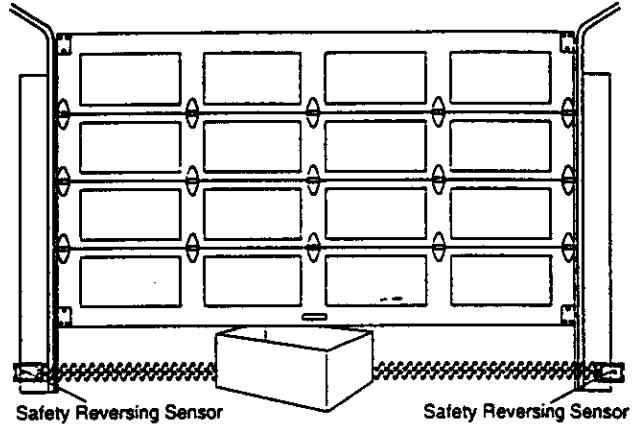

## Adjustment Step 4

### Test the Safety Reverse System

#### Test:

- Place a one-inch board (or a 2x4 laid flat) on the floor, centered under the garage door.
- Operate the door in the down direction. The door **must reverse on striking the obstruction.**

#### Adjustment:

If the door *stops* on the obstruction, it is not traveling far enough in the down direction.

- Increase the DOWN limit by turning the DOWN limit adjustment screw counterclockwise 1/4 turn.
- Repeat the test.

**Make sure limit adjustments do not force the door arm beyond a straight up and down position. See the illustration on page 23.**

- When the door reverses on the one-inch object (or 2x4 laid flat), remove the obstruction and run the opener through 3 or 4 complete travel cycles to test adjustment.

**If the door will not reverse after repeated adjustment attempts, call for professional garage door service.**

 **WARNING**

*Failure to test and adjust the safety reverse system may result in serious injury or death to persons trapped by a closing garage door. Repeat this test once a month and adjust as needed.*

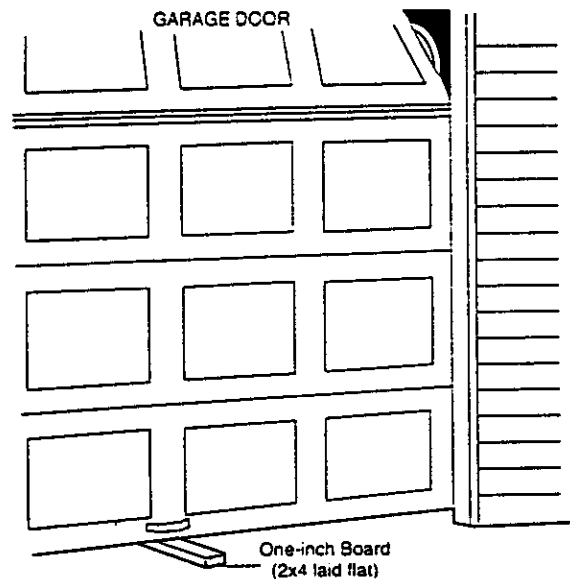

#### Important safety check

Repeat Adjustment Steps 1, 2 and 4 after:

- Each adjustment of door arm length, force controls or limit controls.
- Any repair to or adjustment of the garage door (including springs and hardware).
- Any repair to or buckling of the garage floor.

# IMPORTANT SAFETY INSTRUCTIONS



**WARNING**



**WARNING**

**To reduce the risk of severe injury or death to persons:**

1. READ AND FOLLOW ALL INSTRUCTIONS.
2. Do not permit children either to operate or to play with the opener. Keep a remote control in a location inaccessible to children.
3. Operate opener only when the door is in full view and free from any obstruction. Keep the door in sight until it is completely closed. **NO ONE SHOULD CROSS THE PATH OF THE MOVING DOOR.**
4. Check safety reversal system monthly. See page 26. The garage door **MUST** reverse on contact with a one-inch object (or a 2x4 board laid flat) placed on the floor. If an adjustment is made to either the force or the limit of travel, both adjustments may be needed and the safety reversal system must be checked. *Failure to properly adjust the opener may result in severe injury or death.*
5. If possible, use the emergency release only when the door is in a closed position. Caution should be taken whenever the disconnect cord is actuated with the door open. *Weak or Broken springs may cause the door to fall rapidly, causing injury or death to persons.*
6. **KEEP GARAGE DOORS PROPERLY BALANCED.** See page 3. *An improperly balanced door may not reverse when required and could result in severe injury or death.* Repairs to cables, spring assemblies and other hardware must be made by a professional garage door person.
7. Disconnect the electric power from the garage door opener before making any repairs or removing the covers.
8. **SAVE THESE INSTRUCTIONS.**

Do not exceed 8 complete cycles of door operation per hour in commercial applications.

## Care of Your Opener

### Limit and Force Adjustment Controls

#### Limit Controls

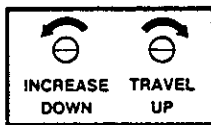

Adjustment Label  
(Located on the left side panel)

#### Force Controls



Adjustment Label  
(Located on the back panel)

Weather conditions may cause some minor changes in door operation requiring some re-adjustments, particularly during the first year of operation.

Pages 24 and 25 refer to the limit and force adjustments. Only a screwdriver is required. Follow the instructions carefully.

Repeat the safety reverse test (page 26) after any adjustment of limits or force.

### The remote control

The lithium batteries should produce power for up to 5 years. To replace batteries, use the visor clip or screwdriver blade to pry open the case, as shown. ("Open" location is stamped on back of transmitter case.) Insert batteries *positive side down*.

**3-FUNCTION**  
Open this end first to avoid cracking housing

**COMPACT**  
Twist here to open

Replace cover as follows. *3-Function remote:* Insert the 3 tabs at the opposite end and snap shut. *Compact 3-Function remote:* Snap shut along both sides.

Dispose of old batteries properly.



**WARNING**

**Keep batteries away from small children. If swallowed, promptly notify doctor.**

## Maintenance Schedule

### Once a Month

Manually operate door. If it is unbalanced or binding, call for professional garage door service. Check to be sure door opens and closes fully. Adjust limits and/or force if necessary. (See pages 24 and 25.) Repeat the safety reverse test. Make any necessary adjustments. (See page 26.)

### Twice a Year

Check chain tension. Disconnect trolley first. Adjust if necessary (See page 10).

### Once a Year

Oil door rollers, bearings and hinges. The opener does not require additional lubrication. Do not grease the door tracks.

# Operation of Your Opener

## Activate the opener with any of the following:

- **The Remote Control:** Hold push button down until the door starts to move.
- **The Door Control.** Hold push button down until the door starts to move.
- **The Outdoor Key Switch or Keyless Entry.** (See Accessories.)

## When the opener is activated with the Safety Reversing Sensor installed and correctly aligned:

1. If open, the door will close. If closed, it will open.
2. If closing, the door will reverse.
3. If opening, the door will stop (allowing space for entry and exit of pets and for fresh air).
4. If the door has been stopped in a partially open position, it will close.
5. If obstructed while closing, the door will reverse.
6. If obstructed while opening, the door will stop.
7. The garage door will reverse in the closing cycle, and the opener light will blink for 5 seconds, when the invisible beam is broken. If fully open, the door will not close when the beam is broken. The sensor has no effect in the opening cycle.

If the sensor is not installed, or is not aligned correctly, the door won't close from any remote control. However, you can close the door with the Door Control, the Outdoor Key Switch, or Keyless Entry, if you activate them *until down travel is complete*. If you release them too soon, the door will reverse.

**The Opener Light** will turn on under the following conditions: When the opener is initially plugged in; when the power is interrupted; when the opener is activated. It will turn off automatically after 4-1/2 minute. Bulb size is 75 watts maximum.

## Operation of the Door Control Button

Press to open or close the door.

Press again to *reverse* the door during the closing cycle or to *stop* the door while it's opening.



## WARNING

**Weak or broken springs could allow an open door to fall (either rapidly or unexpectedly), resulting in serious injury, death or property damage. If possible, use the emergency release rope and handle *only* when the door is fully closed.**

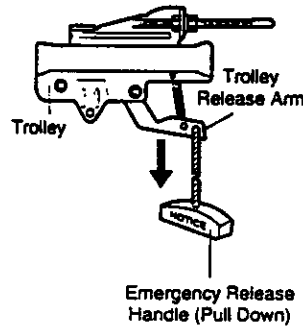

**Manual disconnect position**

## To open the door manually:

The door should be fully closed if possible. Pull down on the red emergency release handle and lift the door manually. To reconnect the door to the opener, press the Door Control push button.

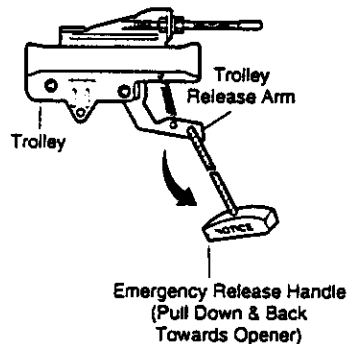

**Lockout position**

**The lockout feature** prevents the trolley from reconnecting automatically. Pull the red emergency release handle down and back (toward the opener). The door can then be raised and lowered manually as often as necessary. To disengage the Lockout Feature, pull the emergency release handle straight down. The trolley will reconnect on the next UP or DOWN operation.

# Receiver and Remote Control Programming

NOTICE: To comply with FCC rules, adjustment or modification of this receiver and/or transmitter are prohibited, except for changing the code setting or replacing the battery. THERE ARE NO OTHER USER SERVICEABLE PARTS.

The remote control has been factory set to operate with the *large* push button. However, you can use either of the two small buttons, if you prefer. And, the 3-function remote control can also activate additional garage door openers and/or light controls.

Below are instructions for programming your opener to match the other buttons on your remote controls and any additional remote controls you may purchase. See available accessories on page 34.

## 53000SRT Series Garage Door Openers (With "SRT" Button)

Your "SRT" garage door opener will operate with as many as four "SRT" portable remote controls and one Multi-Function Keyless Entry.

### To Add A Remote Control

1. Press and *hold* the selected remote push button, see Figure 1.
2. Then press and release the "SRT" (learn) button on the back panel of the opener, Figure 2. The opener light will *flash once*.
3. Release the remote push button.

Now the opener will operate when the remote control push button is pressed.

If you release the remote control push button before the opener light flashes, the opener will not accept the code.

### To Change the Selected Push Button On the Same Remote Control

If you decide to use a different remote control button than originally programmed into the opener, you need to erase *all* the learned codes and reprogram each remote control used to operate the garage door opener.

### To Erase All Remote Control Codes

- Press and hold the "SRT" button on the opener panel until the indicator light turns off (about 6 seconds). *All the codes the opener has learned will be erased.*
- To reprogram, repeat Steps 1-3 for each remote control in use.

Code programming instructions are also located on the opener panel.



## WARNING

Children operating or playing with a garage door opener can injure themselves or others. *The garage door could close and cause serious injury or death. Do not allow children to operate the door control or remote controls.* A moving garage door could injure or kill someone under it. Activate the opener only when you can see the door clearly, it is free of obstructions, and is properly adjusted.

Figure 1

Select a remote control push button to operate opener

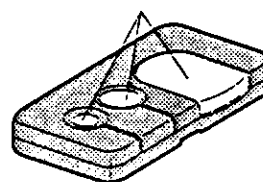

3-Function  
Remote Control

Figure 2

Garage Door Opener  
(With "SRT" Button)

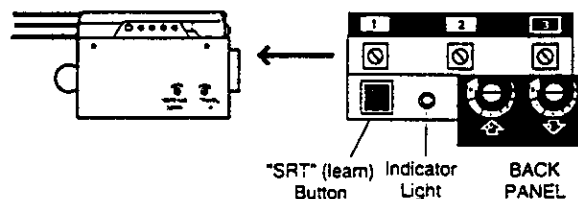

### To Add the Keyless Entry

We recommend that you program your code before you install the Keyless Entry. You will not need assistance, and you can test the reception at the mounting location before installation.

1. Choose a 4-digit code using numbers from 0 to 9. You can use a number more than once (for example, 4, 0, 4, 1). Press the selected code digits on the keypad.
2. Press and *hold* the Enter button while you press the "SRT" (learn) button on the opener panel. The indicator light will blink and the door will begin to move.
3. Release the Enter button. Now the opener has learned the selected keypad code.

To ensure that your portable remote control codes were not disturbed while you were programming the Keyless Entry, test your remotes and reprogram them if necessary.

To change the code at any time, repeat Steps 1-3.

# Having a Problem?

Situation	Probable Cause & Solution
<i>The opener doesn't operate from either the door control or the remote control:</i>	<ol style="list-style-type: none"><li>1. Does the opener have electric power? Plug a lamp into the outlet. If it doesn't light, check the fuse box or the circuit breaker. (Some outlets are controlled by a wall switch.)</li><li>2. Have you disabled all door locks? Review installation instruction warnings on Page 10.</li><li>3. Is there a build-up of ice or snow under the door? The door may be frozen to the ground. Remove any restriction.</li><li>4. The garage door spring may be broken. Have it replaced.</li><li>5. Repeated operation may have tripped the overload protector in the motor. Wait 15 minutes. Try again.</li></ol>
<i>Opener operates from the remote control but not from the door control:</i>	<ol style="list-style-type: none"><li>1. Is the door control button lit? If not, Remove the bell wire from the opener terminal screws. Short the red and white terminals by touching both terminals at the same time with a piece of wire. If the opener runs, check for a faulty wire connection at the door control, a short under the staples, or a broken wire.</li><li>2. Are the wiring connections correct? Review Step 6, page 16.</li></ol>
<i>The door operates from the door control, but not from the remote control:</i>	<ol style="list-style-type: none"><li>1. Does the battery test light glow when the remote control push button is pressed? If not, replace the battery.</li><li>2. Your opener needs to re-learn a remote control code. Refer to Instructions on the opener panel.</li><li>3. Program the receiver to match the remote control code.</li><li>4. Repeat the receiver programming procedure with all remote controls.</li></ol>
<i>The remote control has short range:</i>	<ol style="list-style-type: none"><li>1. Check the battery test light. If the light is dim, change the battery.</li><li>2. Change the location of the remote control in your car.</li><li>3. Check to be sure the antenna on the back panel of opener extends fully downward.</li><li>4. Some installations may have shorter range due to a metal door, foil backed insulation, or metal garage siding.</li></ol> <p><b>Install Antenna Kit, Part No. 41A3504, to increase range.</b></p>
<i>Opener noise is disturbing in living quarters of home:</i>	<p>If operational noise is a problem because of proximity of the opener to the living quarters, the Vibration Isolator Kit 41A3263 can be installed. This kit was designed to minimize vibration to the house and is easy to install.</p>
<i>The garage door opens and closes by itself:</i>	<ol style="list-style-type: none"><li>1. Be sure that all remote control push buttons and battery indicator lights are off.</li><li>2. Remove the bell wire from the door control terminals and operate from the remote control only. If this solves the problem, the door control is faulty (replace), or there is an intermittent short on the wire between the door control and the opener.</li><li>3. Clear memory and reprogram all remote controls.</li></ol>
<i>The door doesn't open completely:</i>	<ol style="list-style-type: none"><li>1. If the door has been working properly but now doesn't open all the way, increase the <i>up force</i>. See page 25.</li><li>2. Is something obstructing the door? Remove the obstruction or repair the door.</li><li>3. If door opens at least 5 feet, the travel limits may need to be increased. One turn equals 2 inches of travel. See page 24.</li></ol> <p><b>Repeat the safety reverse test after the adjustment is complete.</b></p>
<i>The door stops but doesn't close completely:</i>	<p>Review the travel limits adjustment procedures on page 24.</p> <p><b>Repeat the safety reverse test after any adjustment of door arm length, close force or down limit.</b></p>

## Having a Problem? *(continued)*

Situation	Probable Cause & Solution
<b>The door opens but won't close:</b>	<ol style="list-style-type: none"><li>1. If the opener light blinks, check the safety reversing sensor. See page 21.</li><li>2. If the opener light does not blink and it is a new installation, check the down force. See Adjustment Step 2, page 25. For an existing installation, see below. <b>Repeat the safety reverse test after the adjustment is complete.</b></li></ol>
<b>The door reverses for no apparent reason and opener light doesn't blink:</b>	<ol style="list-style-type: none"><li>1. Is something obstructing the door? Pull the emergency release handle. Operate the door manually. If it is unbalanced or binding, call for professional garage door service.</li><li>2. Clear any ice or snow from the garage floor area where the door closes.</li><li>3. Review the force adjustment procedures on page 25.</li><li>4. If door reverses in the <i>fully closed</i> position, decrease the travel limits (page 24). <b>Repeat safety reverse test after the adjustment is complete. The need for occasional adjustment of the force and limit settings is normal. Weather conditions in particular can affect door travel.</b></li></ol>
<b>The door reverses for no apparent reason and opener light blinks for 5 seconds after reversing:</b>	Check the safety reversing sensor. Remove any obstruction or align the receiving eye. See page 21.
<b>The opener light</b>	<p><b>... doesn't turn on:</b> Replace the light bulb (75 watts maximum). Use a <i>standard neck</i> garage door opener bulb if regular bulb burns out.</p> <p><b>... doesn't turn off:</b> There may be a defective ground at the ceiling or wall receptacle. <b>The unit must be grounded.</b></p>
<b>The opener strains or maximum force is needed to operate door:</b>	The door may be out of balance or the springs are broken. <b>Close the door</b> and use the emergency release handle to disconnect the trolley. Open and close the door manually. A properly balanced door will stay in any point of travel while being supported entirely by its springs. If it does not, disconnect the opener and call for professional garage door service. <b>Do not increase the force to operate the opener.</b>
<b>The opener motor hums briefly, then won't work:</b>	<ol style="list-style-type: none"><li>1. The garage door springs are broken. See above.</li><li>2. If the problem occurs on the first operation of the opener, door may be locked. <i>Disable the door lock.</i> If the chain was removed and re-installed, the motor may be out of phase. Remove the chain; cycle the motor to the down position. Observe the drive sprocket. When it turns in a clockwise direction and stops in the down position, reinstall the chain. <b>Repeat the safety reverse test after the adjustment is complete.</b></li></ol>
<b>The opener won't operate due to power failure:</b>	<ol style="list-style-type: none"><li>1. Use the emergency release rope and handle to disconnect the trolley. The door can be opened and closed manually. When power is restored, press the door control button and trolley will automatically reconnect (unless trolley is in lockout position.) See page 28.</li><li>2. The Emergency Key Release accessory (for use on garages with no service door) disconnects the trolley from outside the garage in case of power failure.</li></ol>
<b>The chain droops or sags:</b>	It is normal for the chain to droop slightly in the closed door position. Use the emergency release rope and handle to disconnect the trolley. If the chain returns to the normal height when the trolley is disengaged and the door reverses on a one-inch board (or a 2x4 laid flat), no adjustments are needed. (See page 10.)

# Repair Parts

## Rail Assembly Parts

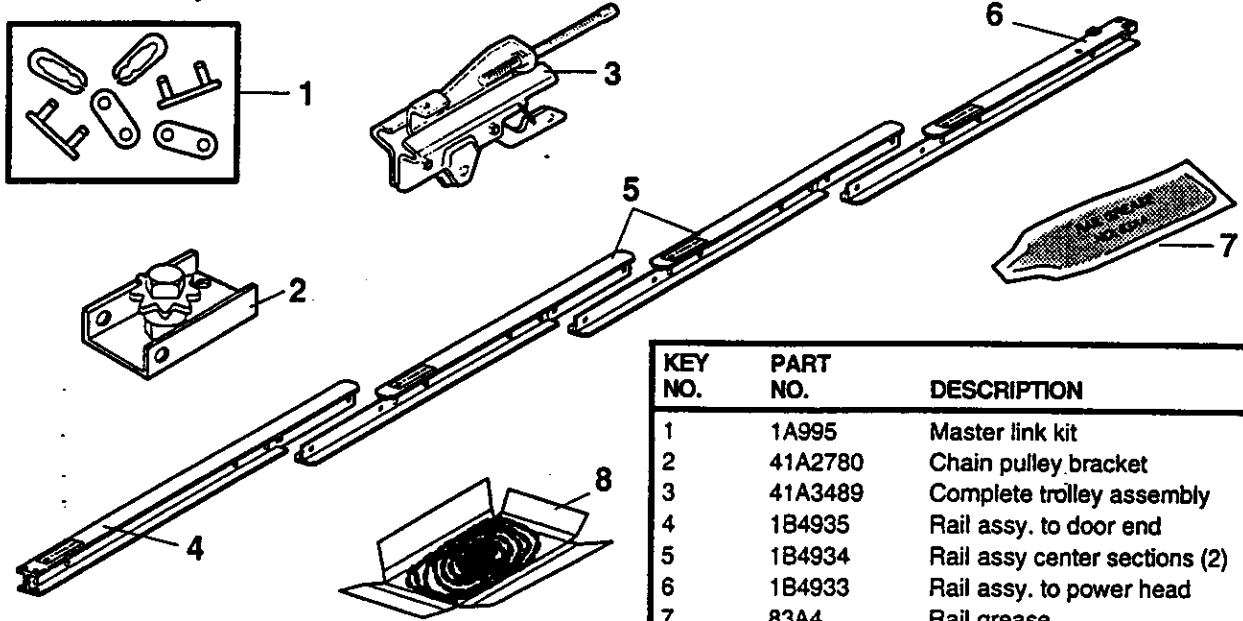

KEY NO.	PART NO.	DESCRIPTION
1	1A995	Master link kit
2	41A2780	Chain pulley bracket
3	41A3489	Complete trolley assembly
4	1B4935	Rail assy. to door end
5	1B4934	Rail assy center sections (2)
6	1B4933	Rail assy. to power head
7	83A4	Rail grease
8	41A4554	Chain
9	41A4937	Rail assy hardware kit (Includes hardware listed on page 5).

## Installation Parts

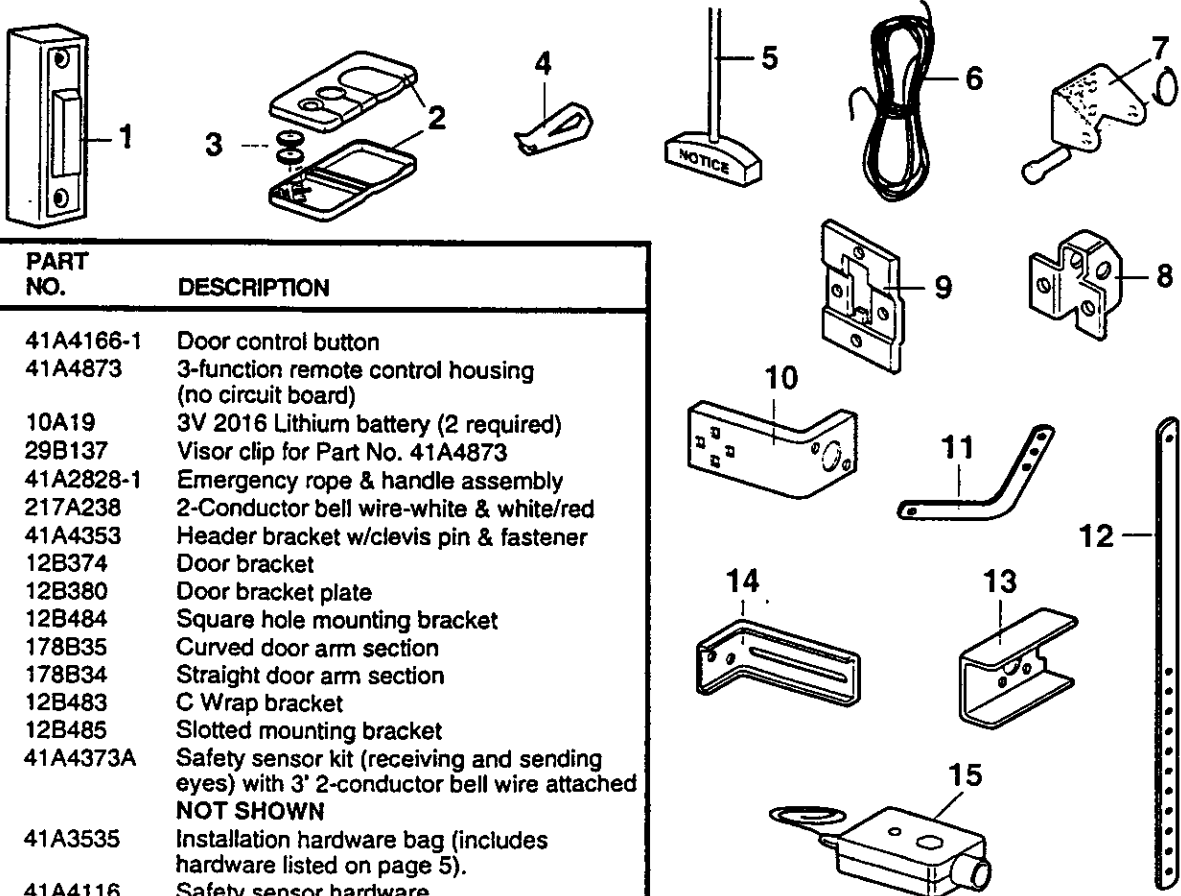

KEY NO.	PART NO.	DESCRIPTION
1	41A4166-1	Door control button
2	41A4873	3-function remote control housing (no circuit board)
3	10A19	3V 2016 Lithium battery (2 required)
4	29B137	Visor clip for Part No. 41A4873
5	41A2828-1	Emergency rope & handle assembly
6	217A238	2-Conductor bell wire-white & white/red
7	41A4353	Header bracket w/clevis pin & fastener
8	12B374	Door bracket
9	12B380	Door bracket plate
10	12B484	Square hole mounting bracket
11	178B35	Curved door arm section
12	178B34	Straight door arm section
13	12B483	C Wrap bracket
14	12B485	Slotted mounting bracket
15	41A4373A	Safety sensor kit (receiving and sending eyes) with 3' 2-conductor bell wire attached
		<b>NOT SHOWN</b>
	41A3535	Installation hardware bag (includes hardware listed on page 5).
	41A4116	Safety sensor hardware
	114A2279	Owner's manual



# Repair Parts



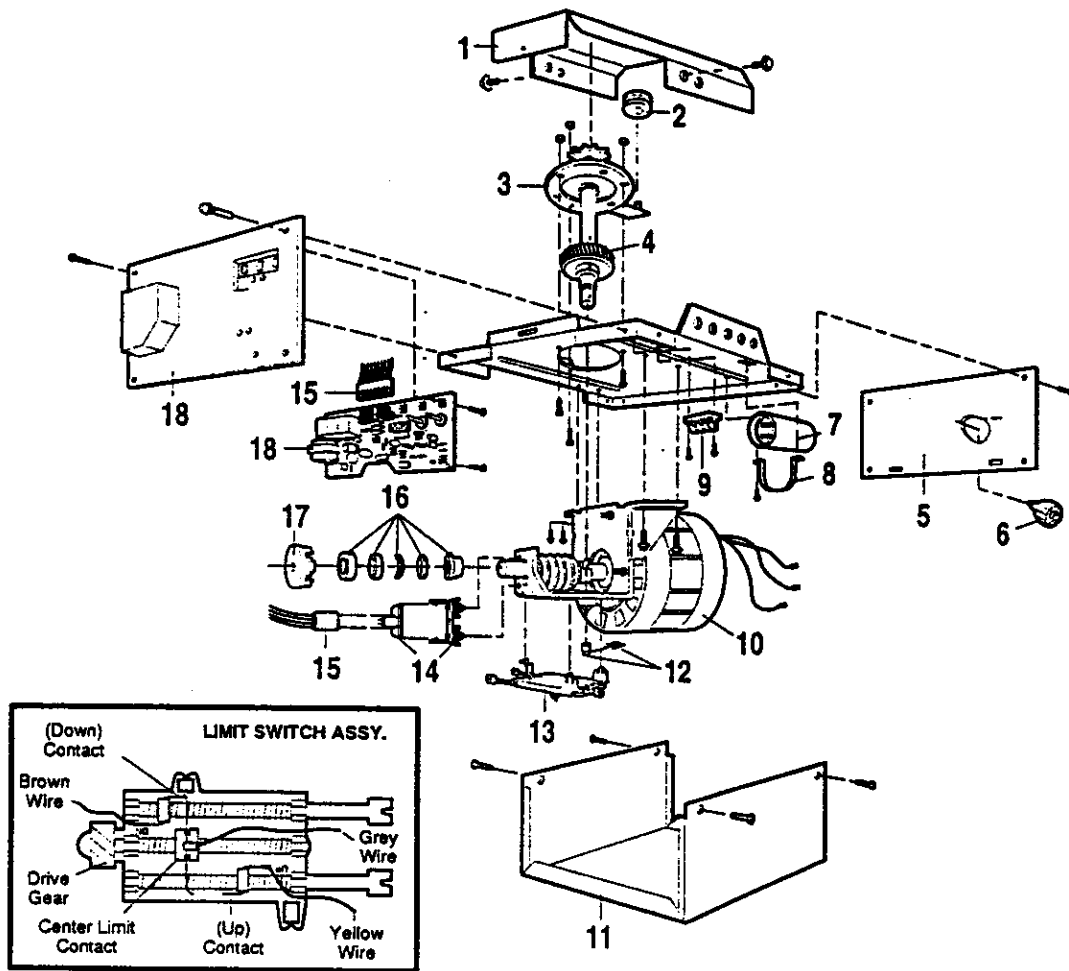

## Opener Assembly Parts



KEY NO.	PART NO.	DESCRIPTION	KEY NO.	PART NO.	DESCRIPTION
1	41C5069	Rail support bracket assembly kit	10	41D4509	Replacement motor & bracket assembly <b>Complete with:</b> Motor, worm, bracket, bearing assembly
2	144B18	Pulley (Chain)	11	41A4936-1	Cover
3	41C4470	Gear and sprocket assy. <b>Complete with:</b> Spring washer Thrust washer Retaining washer Bearing plate Roll pins (2) Drive gear and worm gear Helical gear w/retainer and grease Sprocket shaft plate with screws	12	41A2818	Helical gear & retainer w/grease
4	41A2817	Drive/worm gear kit w/grease Roll pins (2)	13	41D3452	Limit switch assembly
5	143D100	Front end panel	14	41C4398A	RPM sensor assembly
6	175B88M	Light socket	15	41C4246	Wire harness assembly w/plug
7	30B432	Capacitor	16	41A2826	Shaft bearing kit
8	12A461	Capacitor bracket	17	41A2822A	Interruptor cup assembly
9	41A3150	Terminal block with screws	18	41A4252-12	Receiver logic board assembly <b>Complete with:</b> Logic board, end panel with all labels <b>NOT SHOWN</b>
				41A2825	Opener assembly hardware kit (includes screws not designated by a number in illustration).

## Accessories

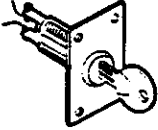
Sears offers many useful accessories for your garage door opener. They are illustrated below with Sears model numbers and descriptions.

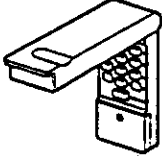
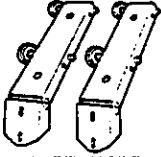
<p>139.53702</p> 	<p><b>Emergency Key Release:</b>  <i>Required</i> for a garage with NO access door. Enables homeowner to open garage door manually from outside by disengaging trolley.</p>	<p>139.53879</p> 	<p><b>3-Function Remote Control:</b>          Includes visor clip.</p>
<p>139.53703</p> 	<p><b>Outdoor Key Switch:</b>          Operates the garage door automatically from outside when remote control is not handy.</p>	<p>139.53859</p> 	<p><b>Compact 3-Function Remote Control:</b>          With loop for attaching key ring.</p>
<p>53589</p> 	<p><b>Support Brackets:</b>          For finished ceilings or where additional support is required, based on garage construction. Includes brackets and fastening hardware.</p>	<p>139.53876</p> 	<p><b>Multi-Function Keyless Entry:</b>          Enables homeowner to operate garage door opener from outside by entering a 4-digit code on specially designed keypad.</p>
<p>139.53709</p> 	<p><b>Door Clearance Brackets:</b>          (For Sectional Doors Only)          Replaces top brackets and rollers on door to reduce height of door travel. For use when installing opener in garage with low headroom clearance.</p>		

# Index

Access Door/Emergency Key Release Accessory .....	4, 34
Chain Tension .....	4, 10, 31
Electrical Safety Warnings.....	2, 10, 18, 27
<b>Garage Door</b>	
Testing for balance, binding and sticking.....	3, 25, 27
Determining high point of travel: .....	11
Disabling existing locks.....	3, 10
Door clearance brackets (for garages with low headroom) .....	11, 34
Force Controls	
Adjustment procedures.....	25
Problems that might require force adjustments .....	30, 31
Safety warnings .....	25, 27
Door hardware .....	3, 10, 11, 16, 27, 28
Maintenance Instruction Label.....	10, 16
Reinforcement requirements .....	4, 22
Removing all ropes .....	3, 10
Possible door damage .....	3, 14, 22
Travel Limits	
Adjustment procedures.....	24
Problems that might require limit adjustments.....	30, 31
Safety warnings .....	24, 27
<b>Manual (Emergency) Release Rope &amp; Handle</b>	
Lockout feature .....	28
Manual disconnect.....	28, 31
Safety warnings .....	10, 17, 27, 28
<b>Opener Terminals</b>	
Door control connections .....	16
Safety reversing sensor connections.....	21
<b>Operational Noise</b>	
Sprocket noise .....	10
Vibration noise (isolator kit) .....	30
<b>Receiver and Remote Controls</b>	
Programming the receiver .....	29
Erasing all codes .....	29
Safety warning.....	29
Activating other openers .....	29
Problems with remote control operation .....	30
<b>Safety Reverse Test Procedure.....</b>	<b>26</b>
Testing required.....	10, 26, 30, 31
Safety reverse system problems	
Securing header bracket to wall .....	11
Adjusting travel limits.....	24
Applying excessive force on the door .....	25
Buckling or uneven floor .....	4
<b>Safety Warnings.....</b>	<b>2, 3, 8, 9, 10, 11, 14, 15, 16, 17, 18, 19, 22, 24, 25, 26, 27, 28, 29</b>
<b>User Instruction Label for garage wall .....</b>	<b>10, 16</b>

For professional installation  
Call 24 hours a day, 7 days a week  
**1-800-865-6500**

For the repair or replacement parts you need  
Call 7 am – 7 pm, 7 days a week  
**1-800-366-PART**  
(1-800-366-7278)

For in-home major brand repair service  
Call 24 hours a day, 7 days a week  
**1-800-4-REPAIR**  
(1-800-473-7247)

For the location of a Sears Repair Service Center in your area  
Call 24 hours a day, 7 days a week  
**1-800-488-1222**

For information on purchasing a Sears Maintenance Agreement or to inquire  
about an existing Agreement  
Call 9 am – 5 pm, Monday-Saturday  
**1-800-827-6655**

The model number label is located on the front end panel of your opener.  
When requesting service or ordering parts, always give the following  
information:

- Product Type
- Model Number
- Part Number
- Part Description



### SEARS WARRANTY

#### FULL 90-DAY WARRANTY ON GARAGE DOOR OPENER

For 90 days from the date of purchase, Sears will repair this Garage Door Opener, free of charge, if defective in material or workmanship.

#### LIMITED WARRANTY

From the 91st day until one year from the date of purchase, Sears will furnish replacement parts for any defective parts, free of charge. You pay for labor.

#### LIMITATION ON LIABILITY

**SEARS WILL NOT BE LIABLE FOR LOSS OR DAMAGE TO PROPERTY OR ANY INCIDENTAL OR CONSEQUENTIAL LOSS OR EXPENSE FROM PROPERTY DAMAGE DUE DIRECTLY OR INDIRECTLY FROM THE USE OF THIS PRODUCT.** Some states do not allow the exclusion or limitation of incidental or consequential damages, so the above limitation or exclusion may not apply to you.

This warranty does not cover light bulbs or repair parts necessary because of operator abuse or negligence, including the failure to install, adjust and operate this garage door opener according to instructions contained in the owner's manual.

WARRANTY SERVICE IS AVAILABLE BY SIMPLY CONTACTING THE NEAREST SEARS CENTER/DEPARTMENT IN THE UNITED STATES.

This warranty applies only while this product is in use in the United States.

This warranty gives you specific legal rights, and you may also have other rights which vary from state to state.

Sears, Roebuck and Co., Dept. 817WA, Hoffman Estates, IL 60179