

Owner's Manual

# CRAFTSMAN

## 20.5 HP ELECTRIC START 42" MOWER AUTOMATIC LAWN TRACTOR

# EZ<sup>3</sup>

Model No.  
917.270840

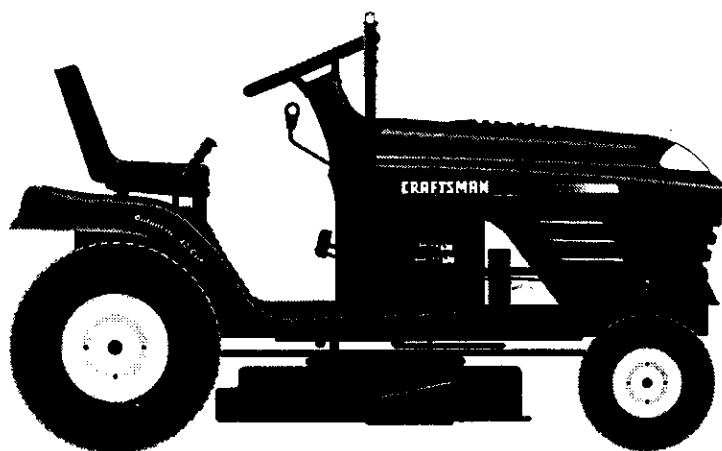

- Safety
- Assembly
- Operation
- Maintenance
- Repair Parts



This product has a low emission engine which operates differently from previously built engines. Before you start the engine, read and understand this Owner's Manual.

### CAUTION:

Read and follow all Safety Rules and Instructions before operating this equipment.

For answers to your questions about this product, Call:

**1-800-659-5917**  
Sears Craftsman Help Line  
5 am - 5 pm, Mon - Sat

Sears, Roebuck and Co., Hoffman Estates, IL 60179

## TABLE OF CONTENTS

Warranty .....	2	Maintenance .....	19
Safety Rules .....	2	Service and Adjustments .....	23
Product Specifications .....	5	Storage .....	29
Assembly .....	8	Troubleshooting .....	31
Operation .....	12	Repair Parts .....	34
Maintenance Schedule .....	19	Parts Ordering .....	Back Cover

## WARRANTY

### LIMITED TWO YEAR WARRANTY ON CRAFTSMAN RIDING EQUIPMENT

For two (2) years from the date of purchase, if this Craftsman Riding Equipment is maintained, lubricated and tuned up according to the instructions in the owner's manual, Sears will repair or replace, free of charge, any parts found to be defective in material or workmanship.

This Warranty does not cover:

- Expendable items which become worn during normal use, such as blades, spark plugs, air cleaners, belts, etc.
- Tire replacement or repair caused by punctures from outside objects, such as nails, thorns, stumps, or glass.
- Repairs necessary because of operator abuse, negligence, improper storage or accident or the failure to maintain the equipment according to the instructions contained in the owner's manual.
- Riding equipment used for commercial or rental purposes.

### LIMITED 90 DAY WARRANTY ON BATTERY

For ninety (90) days from date of purchase, if any battery included with this riding equipment proves defective in material or workmanship and our testing determines the battery will not hold a charge, Sears will replace the battery at no charge. In-home warranty service on your Craftsman riding equipment is available at no charge for 30 days from the date of purchase. Please contact your nearest service center. After 30 days from the date of purchase, warranty service is available by taking your Craftsman riding equipment to your nearest Sears Service Center. (In-home warranty service will still be available after 30 days from the date of purchase but a standard trip charge will apply). This warranty applies only while this product is in the United States. This Warranty gives you specific legal rights, and you may also have other rights which may vary from state to state.

Sears, Roebuck and Co., D/817 WA, Hoffman Estates, IL 60179

## SAFETY RULES

### GENERAL OPERATION

- Read, understand, and follow all instructions in the manual and on the machine before starting.
- Only allow responsible adults, who are familiar with the instructions, to operate the machine.
- Clear the area of objects such as rocks, toys, wire, etc., which could be picked up and thrown by the blade.
- Be sure the area is clear of other people before mowing. Stop machine if anyone enters the area.
- Never carry passengers.
- Do not mow in reverse unless absolutely necessary. Always look down and behind before and while backing.
- Be aware of the mower discharge direction and do not point it at anyone. Do not operate the mower without either the entire grass catcher or the guard in place.
- Slow down before turning.
- Never leave a running machine unattended. Always turn off blades, set parking brake, stop engine, and remove keys before dismounting.

## SAFETY RULES

- Turn off blades when not mowing.
- Stop engine before removing grass catcher or unclogging chute.
- Mow only in daylight or good artificial light.
- Do not operate the machine while under the influence of alcohol or drugs.
- Watch for traffic when operating near or crossing roadways.
- Use extra care when loading or unloading the machine into a trailer or truck.

### SLOPE OPERATION

Slopes are a major factor related to loss-of-control and tipover accidents, which can result in severe injury or death. All slopes require extra caution. If you cannot back up the slope or if you feel uneasy on it, do not mow it.

#### DO:

- Mow up and down slopes, not across.
- Remove obstacles such as rocks, tree limbs, etc.
- Watch for holes, ruts, or bumps. Uneven terrain could overturn the machine. Tall grass can hide obstacles.
- Use slow speed. Choose a low gear so that you will not have to stop or shift while on the slope.
- Follow the manufacturer's recommendations for wheel weights or counterweights to improve stability.
- Use extra care with grass catchers or other attachments. These can change the stability of the machine.
- Keep all movement on the slopes slow and gradual. Do not make sudden changes in speed or direction.
- Avoid starting or stopping on a slope. If tires lose traction, disengage the blades and proceed slowly straight down the slope.

#### DO NOT:

- *Do not* turn on slopes unless necessary, and then, turn slowly and gradually downhill, if possible.
- *Do not* mow near drop-offs, ditches, or embankments. The mower could suddenly turn over if a wheel is over the edge of a cliff or ditch, or if an edge caves in.
- *Do not* mow on wet grass. Reduced traction could cause sliding.

- *Do not* try to stabilize the machine by putting your foot on the ground.
- *Do not* use grass catcher on steep slopes.

### CHILDREN

Tragic accidents can occur if the operator is not alert to the presence of children. Children are often attracted to the machine and the mowing activity. *Never* assume that children will remain where you last saw them.

- Keep children out of the mowing area and under the watchful care of another responsible adult.
- Be alert and turn machine off if children enter the area.
- Before and when backing, look behind and down for small children.
- Never carry children. They may fall off and be seriously injured or interfere with safe machine operation.
- Never allow children to operate the machine.
- Use extra care when approaching blind corners, shrubs, trees, or other objects that may obscure vision.

### SERVICE

- Use extra care in handling gasoline and other fuels. They are flammable and vapors are explosive.
  - Use only an approved container.
  - Never remove gas cap or add fuel with the engine running. Allow engine to cool before refueling. Do not smoke.
  - Never refuel the machine indoors.
  - Never store the machine or fuel container inside where there is an open flame, such as a water heater.
- Never run a machine inside a closed area.
- Keep nuts and bolts, especially blade attachment bolts, tight and keep equipment in good condition.
- Never tamper with safety devices. Check their proper operation regularly.
- Keep machine free of grass, leaves, or other debris build-up. Clean oil or fuel spillage. Allow machine to cool before storing.
- Stop and inspect the equipment if you strike an object. Repair, if necessary, before restarting.

## SAFETY RULES

- Never make adjustments or repairs with the engine running.
- Grass catcher components are subject to wear, damage, and deterioration, which could expose moving parts or allow objects to be thrown. Frequently check components and replace with manufacturer's recommended parts, when necessary.
- Mower blades are sharp and can cut. Wrap the blade(s) or wear gloves, and use extra caution when servicing them.
- Check brake operation frequently. Adjust and service as required.

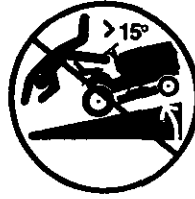

- Be sure the area is clear of other people before mowing. Stop machine if anyone enters the area.
- Never carry passengers.
- Do not mow in reverse unless absolutely necessary. Always look down and behind before and while backing.
- Never carry children. They may fall off and be seriously injured or interfere with safe machine operation.
- Keep children out of the mowing area and under the watchful care of another responsible adult.
- Be alert and turn machine off if children enter the area.
- Before and when backing, look behind and *down* for small children.
- Mow up and down slopes (15° Max), not across.
- Remove obstacles such as rocks, tree limbs, etc.
- Watch for holes, ruts, or bumps. Uneven terrain could overturn the machine. *Tall grass can hide obstacles.*
- Use slow speed. Choose a low gear so that you will not have to stop or shift while on the slope.
- Avoid starting or stopping on a slope. If tires lose traction, disengage the blades and proceed slowly *straight* down the slope.
- *Do not* turn on slopes unless necessary, and then, turn slowly and gradually downhill, if possible.

▲ Look for this symbol to point out important safety precautions. It means CAUTION!!! BECOME AWARE!!! YOUR SAFETY IS INVOLVED.

▲ **WARNING:** The engine exhaust from this product contains chemicals known to the State of California to cause cancer, birth defects, or other reproductive harm.

▲ **CAUTION:** In order to prevent accidental starting when setting up, transporting, adjusting or making repairs always disconnect spark plug wire and place wire where it cannot contact spark plug.

## PRODUCT SPECIFICATIONS

GASOLINE CAPACITY AND TYPE:	3.5 GALLONS UNLEADED REGULAR
OIL TYPE (API-SF/SG/SH):	SAE 30 (above 32°F) SAE 5W-30 (below 32°F)
OIL CAPACITY:	3.0 PINTS
SPARK PLUG: (GAP: .030")	Champion RJ19LM OR J19LM
VALVE CLEARANCE: INTAKE:	.005-.007
EXHAUST:	.009-.011
GROUND SPEED (MPH):	FORWARD: 0 - 5.5 REVERSE: 0 - 2.4
TIRE PRESSURE:	FRONT: 14 PSI REAR: 10 PSI
CHARGING SYSTEM:	3 AMPS BATTERY 5 AMPS HEADLIGHTS
BATTERY:	AMP/HR:30 MIN. CCA:240 CASE SIZE: U1R
BLADE BOLT TORQUE:	27-35 FT. LBS.

**CONGRATULATIONS** on your purchase of a Craftsman Tractor. It has been designed, engineered and manufactured to give you the best possible dependability and performance.

Should you experience any problem you cannot easily remedy, please contact your nearest Sears Authorized Service Center. We have competent, well-trained technicians and the proper tools to service or repair this tractor.

Please read and retain this manual. The instructions will enable you to assemble and maintain your tractor properly. Always observe the "SAFETY RULES".

### MAINTENANCE AGREEMENT

A Sears Maintenance Agreement is available on this product. Contact your nearest Sears store for details.

### CUSTOMER RESPONSIBILITIES

- Read and observe the safety rules.
- Follow a regular schedule in maintaining, caring for and using your tractor.
- Follow the instructions under "Maintenance" and "Storage" sections of this owner's manual.

**▲WARNING:** This tractor is equipped with an internal combustion engine and should not be used on or near any unimproved forest-covered, brush-covered or grass-covered land unless the engine's exhaust system is equipped with a spark arrester meeting applicable local or state laws (if any). If a spark arrester is used, it should be maintained in effective working order by the operator.

In the state of California the above is required by law (Section 4442 of the California Public Resources Code). Other states may have similar laws. Federal laws apply on federal lands. A spark arrester for the muffler is available through your nearest Sears Authorized Service Center (See REPAIR PARTS section of this manual).

# CONTENTS OF HARDWARE PACK

Parts Bag contents shown full size

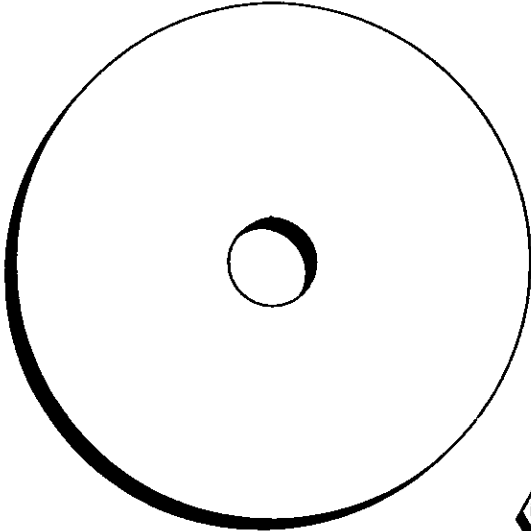

(1) Large Flat Washer



(1) Hex Bolt 5/16-18 x 1-1/4



(1) Lockwasher 3/8



(1) Locknut 5/16-18

(1) Hex Bolt  
3/8-16 x 1

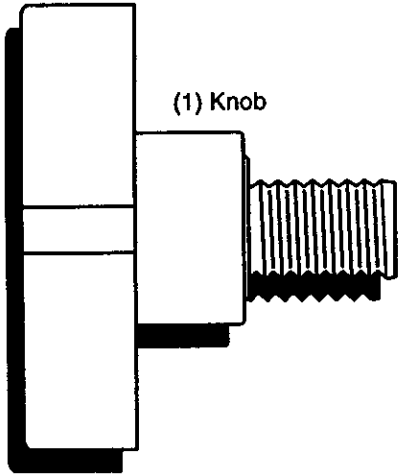
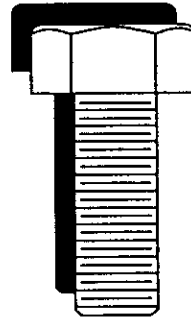

(1) Knob

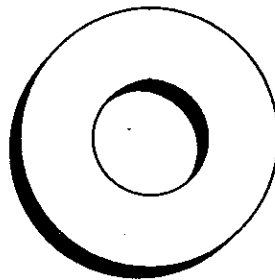

(1) Washer  
17/32 x 1-3/16 x 12 Gauge

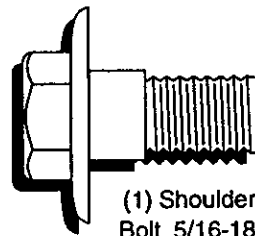

(1) Shoulder  
Bolt 5/16-18

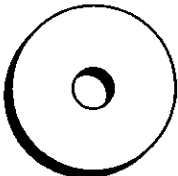

(2) Washers  
3/16 x 3/4 x 16 Gauge



(2) Lock  
Washers #10

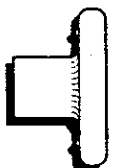

(2) Weld  
Nuts #10



(2) Screws #10 x 5/8

# CONTENTS OF HARDWARE PACK

## Parts packed separately in carton

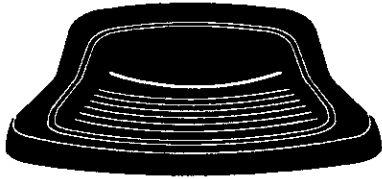

Seat

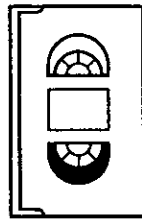

Video  
Cassette

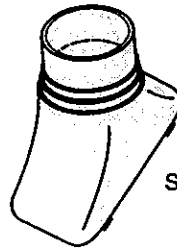

Steering  
Boot

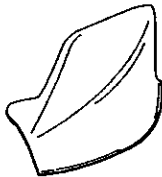

Mulcher  
Plate



Manual

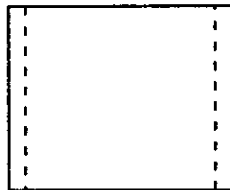

Parts Bag

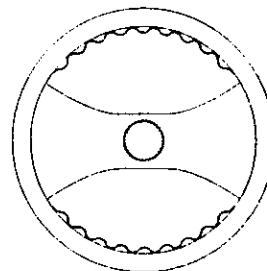

Steering  
Wheel

## Parts Bag contents not shown full size

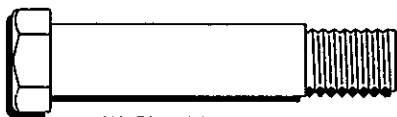

(2) Shoulder  
Bolts

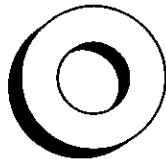

(2) Washers 3/8  
x 7/8 x 14 Gauge



(2) Center-  
lock Nuts

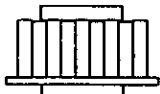

Steering Wheel Adapter



(2) Keys

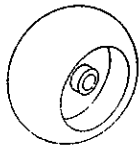

(2) Gauge  
Wheels

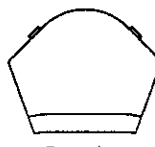

Steering  
Wheel Insert

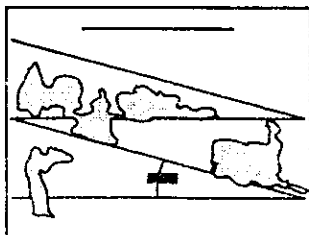

Slope Sheet

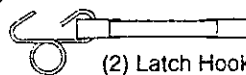

(2) Latch Hook  
Assemblies

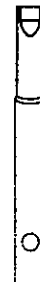

Steering  
Extension  
Shaft

## ASSEMBLY

Your new tractor has been assembled at the factory with exception of those parts left unassembled for shipping purposes. To ensure safe and proper operation of your tractor all parts and hardware you assemble must be tightened securely. Use the correct tools as necessary to insure proper tightness. Review the video cassette before you begin.

### TOOLS REQUIRED FOR ASSEMBLY

A socket wrench set will make assembly easier. Standard wrench sizes you need are listed below.

- |                   |                                  |
|-------------------|----------------------------------|
| (1) 9/16" wrench  | (1) 3/4" Socket w/ drive ratchet |
| (1) 3/4" wrench   | (1) Phillips Screwdriver         |
| (2) 1/2" wrench   | (1) Tire pressure gauge          |
| (1) Utility knife |                                  |
| (1) Pliers        |                                  |

When right or left hand is mentioned in this manual, it means, from your point of view, when you are in the operating position (seated behind the steering wheel).

### TO REMOVE TRACTOR FROM CARTON

#### UNPACK CARTON

- Remove all accessible loose parts and parts boxes from shipping carton (See page 6).
- Cut, from top to bottom, along lines on all four corners of shipping carton, and lay panels flat.
- Check for any additional loose parts or boxes and remove.

### BEFORE ROLLING TRACTOR OFF SKID

#### ATTACH STEERING WHEEL

#### ASSEMBLE EXTENSION SHAFT AND BOOT

- Slide extension shaft onto lower steering shaft. Align mounting holes in extension and lower shafts and install 5/16 hex bolt and locknut. Tighten securely.

**IMPORTANT:** Tighten bolt and nut securely to 18-22 ft. lbs. torque.

- Place tabs of steering boot over tab slots in dash and push down to secure.

#### INSTALL STEERING WHEEL

- Position front wheels of the tractor so they are pointing straight forward.
- Slide steering wheel adapter onto steering shaft extension.
- Position steering wheel so cross bars are horizontal (left to right) and slide inside boot and onto adapter.

- Assemble large flat washer, 3/8 lock washer, 3/8 hex bolt and tighten securely.
- Snap steering wheel insert into center of steering wheel.
- Remove protective materials from tractor hood and grill.

**IMPORTANT:** Check for and remove any staples in skid that may puncture tires where tractor is to roll off skid.

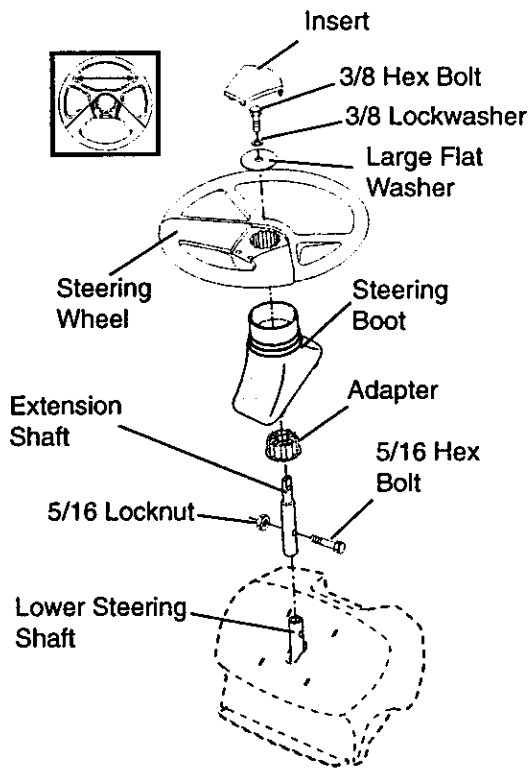

### TO ROLL TRACTOR OFF SKID (See Operation section for location and function of controls)

- Press lift lever plunger and raise attachment lift lever to its highest position.
- Release parking brake by depressing clutch/brake pedal.
- Place freewheel control in freewheeling position to disengage transmission (See "TO TRANSPORT" in the Operation section of this manual).
- Roll tractor forward off skid.
- Remove banding holding discharge guard up against tractor.



## HOW TO SET UP YOUR TRACTOR CHECK BATTERY

- Lift hood to raised position.
- If this battery is put into service after month and year indicated on label (label located between terminals) charge battery for minimum of one hour at 6-10 amps. (See "BATTERY" in MAINTENANCE section of this manual for charging instructions).

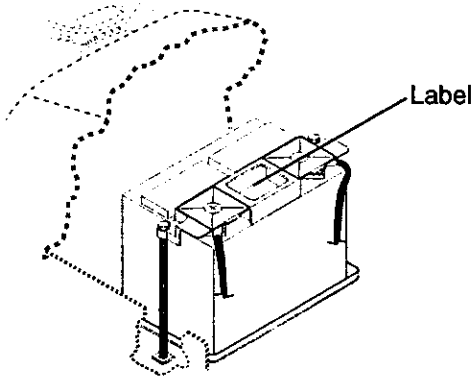

## INSTALL SEAT

Adjust seat before tightening adjustment knob.

- Remove cardboard packing on seat pan.
- Place seat on seat pan and assemble shoulder bolt. Tighten shoulder bolt securely.
- Assemble adjustment knob and flat washer loosely. Do not tighten.
- Lower seat into operating position and sit on seat.
- Slide seat until a comfortable position is reached which allows you to press clutch/brake pedal all the way down.
- Get off seat without moving its adjusted position.
- Raise seat and tighten adjustment knob securely.

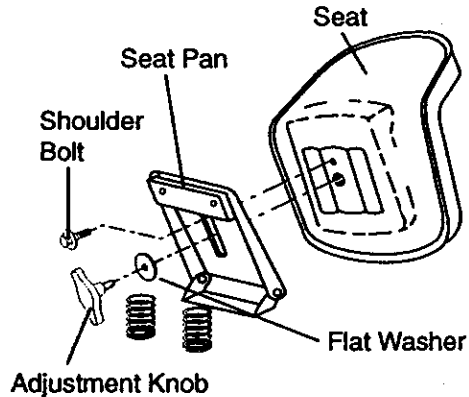

**INSTALL MULCHER PLATE**

- Install two latch hooks to mulcher plate using screw, washer, lock washer, and weld nut as shown.

**NOTE:** Pre-assemble weld nut to latch hook by inserting weld nut from the top with hook pointing down.

- Tighten hardware securely.
- Raise and hold deflector shield in up-right position.
- Place front of mulcher plate over front of mower deck opening and slide into place, as shown.
- Hook front latch into hole on front of mower deck.
- Hook rear latch into hole on back of mower deck.

**CAUTION:** Do not remove discharge guard from mower. Raise and hold guard when attaching mulcher plate and allow it to rest on plate while in operation.

**TO CONVERT TO BAGGING OR DISCHARGING**

Simply remove mulcher plate and store in a safe place. Your mower is now ready for discharging or installation of optional grass catcher accessory.

**NOTE:** It is not necessary to change blades. The mulcher blades are designed for discharging and bagging also.

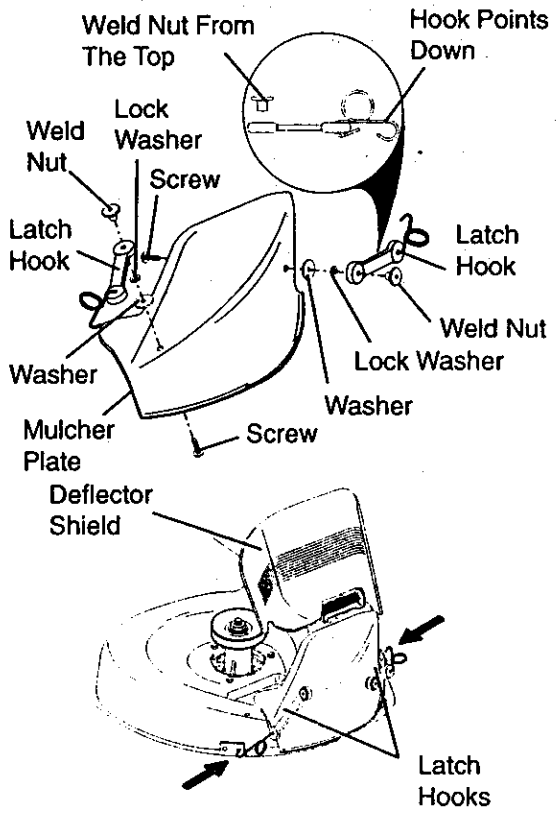

## ASSEMBLE GAUGE WHEELS TO MOWER DECK

The gauge wheels are designed to keep the mower deck in proper position when operating mower. Be sure they are properly adjusted to ensure optimum mower performance.

- Assemble gauge wheels with tractor on a flat level surface.
- Adjust mower to desired cutting height (See "TO ADJUST MOWER CUTTING HEIGHT" in the Operation section of this manual).
- With mower in desired height of cut position, gauge wheels should be assembled so they are slightly off the ground. Install gauge wheel in appropriate hole with shoulder bolt, 3/8 washer, and 3/8-16 locknut and tighten securely.
- Repeat for opposite side installing gauge wheel in same adjustment hole.

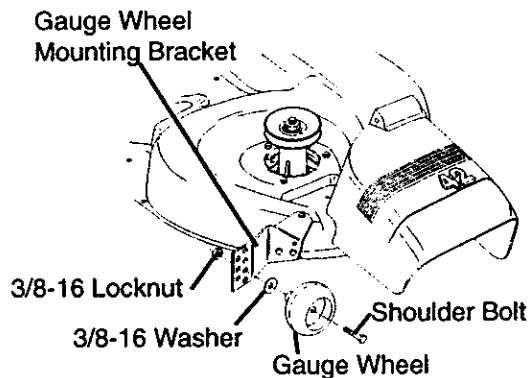

## CHECK TIRE PRESSURE

The tires on your tractor were overinflated at the factory for shipping purposes. Correct tire pressure is important for best cutting performance.

- Reduce tire pressure to PSI shown in "PRODUCT SPECIFICATIONS" on page 5 of this manual.

## CHECK DECK LEVELNESS

For best cutting results, mower housing should be properly leveled. See "TO LEVEL MOWER HOUSING" in the Service and Adjustments section of this manual.

## CHECK FOR PROPER POSITION OF ALL BELTS

See the figures that are shown for replacing motion and mower blade drive belts in the Service and Adjustments section of this manual. Verify that the belts are routed correctly.

## CHECK BRAKE SYSTEM

After you learn how to operate your tractor, check to see that the brake is properly adjusted. See "TO ADJUST BRAKE" in the Service and Adjustments section of this manual.

## ✓CHECKLIST

PLEASE REVIEW THE FOLLOWING CHECKLIST:

- ✓ All assembly instructions have been completed.
- ✓ No remaining loose parts in carton.
- ✓ Battery is properly prepared and charged. (Minimum 1 hour at 6 amps).
- ✓ Seat is adjusted comfortably and tightened securely.
- ✓ All tires are properly inflated. (For shipping purposes, the tires were overinflated at the factory).
- ✓ Be sure mower deck is properly leveled side-to-side/front-to-rear for best cutting results. (Tires must be properly inflated for leveling).
- ✓ Check mower and drive belts. Be sure they are routed properly around pulleys and inside all belt keepers.
- ✓ Check wiring. See that all connections are still secure and wires are properly clamped.
- ✓ Before driving tractor, be sure free-wheel control is in drive position.

WHILE LEARNING HOW TO USE YOUR TRACTOR, PAY EXTRA ATTENTION TO THE FOLLOWING IMPORTANT ITEMS:

- ✓ Engine oil is at proper level.
- ✓ Fuel tank is filled with fresh, clean, regular unleaded gasoline.
- ✓ Become familiar with all controls - their location and function. Operate them before you start the engine.
- ✓ Be sure brake system is in safe operating condition.
- ✓ It is important to purge the transmission before operating your tractor for the first time. Follow proper starting and transmission purging instructions (See "TO START ENGINE" and "PURGE TRANSMISSION" in the Operation section of this manual).

# OPERATION

These symbols may appear on your tractor or in literature supplied with the product. Learn and understand their meaning.

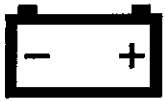

BATTERY



CAUTION OR WARNING



REVERSE



FORWARD



FAST



SLOW



ENGINE ON



ENGINE OFF



OIL PRESSURE

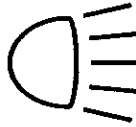

LIGHTS ON



OVER TEMP LIGHT



MOWER LIFT



FUEL



CHOKE



MOWER HEIGHT



PARKING BRAKE LOCKED



UNLOCKED



MOWER LIFT



ATTACHMENT CLUTCH ENGAGED



REVERSE



NEUTRAL



HIGH



LOW



PARKING BRAKE

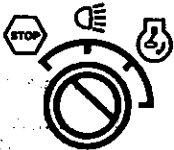

IGNITION



ATTACHMENT CLUTCH DISENGAGED



KEEP AREA CLEAR



SLOPE HAZARDS



(SEE SAFETY RULES SECTION)



DANGER, KEEP HANDS AND FEET AWAY

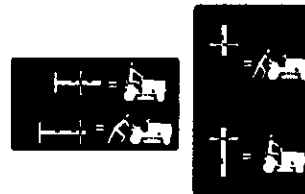

FREE WHEEL (Automatic Models only)

## KNOW YOUR TRACTOR

### READ THIS OWNER'S MANUAL AND SAFETY RULES BEFORE OPERATING YOUR TRACTOR

Compare the illustrations with your tractor to familiarize yourself with the locations of various controls and adjustments. Save this manual for future reference.

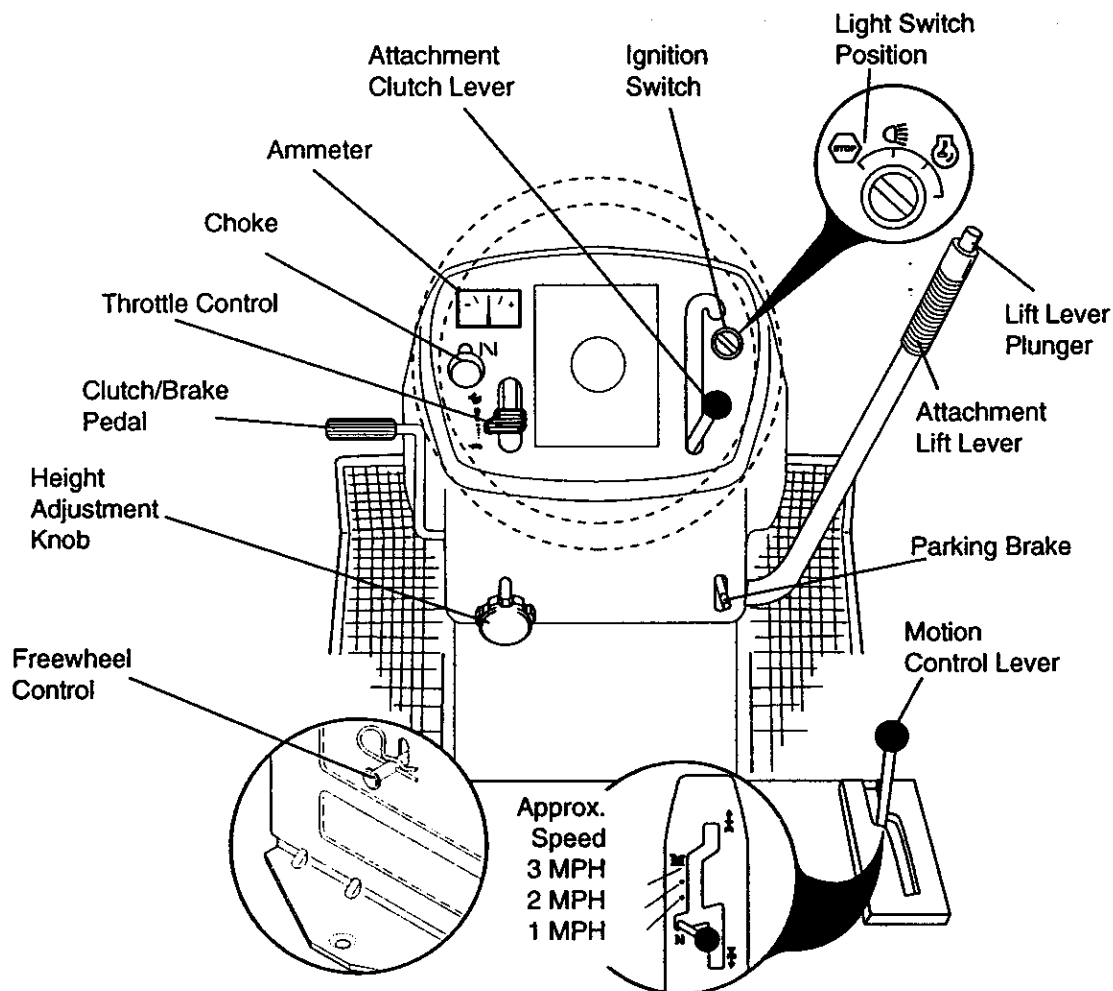

---

Our tractors conform to the safety standards of the American National Standards Institute.

---

**ATTACHMENT CLUTCH LEVER:** Used to engage the mower blades, or other attachments mounted to your tractor.

**LIGHT SWITCH:** Turns the headlights on and off.

**CHOKE CONTROL:** Used when starting a cold engine.

**THROTTLE CONTROL:** Used to control engine speed.

**CLUTCH/BRAKE PEDAL:** Used for declutching and braking the tractor and starting the engine.

**FREEWHEEL CONTROL:** Disengages transmission for pushing or slowly towing the tractor with the engine off.

**HEIGHT ADJUSTMENT KNOB:** Used to adjust the mower cutting height.

**MOTION CONTROL LEVER:** Selects the speed and direction of the tractor.

**ATTACHMENT LIFT LEVER:** Used to raise and lower the mower deck or other attachments mounted to your tractor.

**LIFT LEVER PLUNGER:** Used to release attachment lift lever when changing its position.

**IGNITION SWITCH:** Used for starting and stopping the engine.

**AMMETER:** Indicates battery charging (+) or discharging (-).

**PARKING BRAKE:** Locks clutch/brake into the brake position.



The operation of any tractor can result in foreign objects thrown into the eyes, which can result in severe eye damage. Always wear safety glasses or eye shields while operating your tractor or performing any adjustments or repairs. We recommend a wide vision safety mask over spectacles, or standard safety glasses.

## HOW TO USE YOUR TRACTOR

Your tractor is equipped with an operator presence sensing switch. When engine is running, any attempt by the operator to leave the seat without first setting the parking brake will shut off the engine.

### TO SET PARKING BRAKE

- Depress clutch/brake pedal into full "BRAKE" position and hold.
- Place parking brake lever in "ENGAGED" position and release pressure from clutch/brake pedal. Pedal should remain in "BRAKE" position. Make sure parking brake will hold tractor secure.

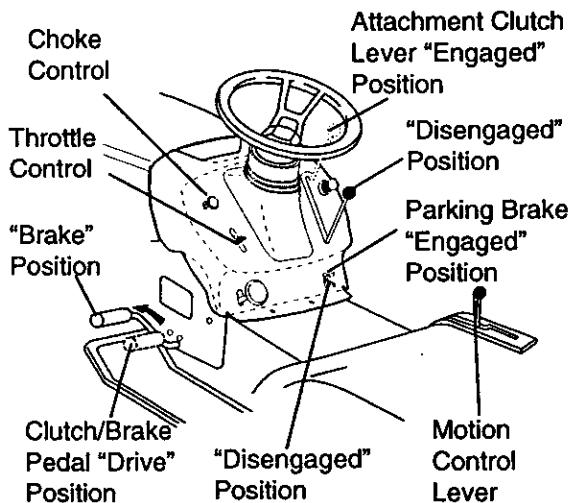

## STOPPING

### MOWER BLADES -

- To stop mower blades, move attachment clutch lever to "DISENGAGED" position.

### GROUND DRIVE -

- To stop ground drive, depress clutch/brake pedal into full "BRAKE" position.
- Move motion control lever to neutral (N) position.

**IMPORTANT:** The motion control lever does not return to neutral (N) position when the clutch/brake pedal is depressed.

### ENGINE -

- Move throttle control to slow position.

**NOTE:** Failure to move throttle control to slow position and allowing engine to idle before stopping may cause engine to "backfire".

- Turn ignition key to "OFF" position and remove key. Always remove key when leaving tractor to prevent unauthorized use.

- Never use choke to stop engine.

**IMPORTANT:** Leaving the ignition switch in any position other than "OFF" will cause the battery to be discharged, (dead).

**NOTE:** Under certain conditions when tractor is standing idle with the engine running, hot engine exhaust gases may cause "browning" of grass. To eliminate this possibility, always stop engine when stopping tractor on grass areas.

**CAUTION:** Always stop tractor completely, as described above, before leaving the operator's position; to empty grass catcher, etc.

### THROTTLE CONTROL

Always operate engine at full throttle.

- Operating engine at less than full throttle reduces the battery charging rate.
- Full throttle offers the best bagging and mower performance.

### CHOKE CONTROL

Use choke control whenever you are starting a cold engine. Do not use to start a warm engine.

- To engage choke control, pull knob out. Slowly push knob in to disengage.

### TO MOVE FORWARD AND BACKWARD

The direction and speed of movement is controlled by the motion control lever.

- Start tractor with motion control lever in neutral (N) position.
- Release parking brake and clutch/brake pedal.
- Slowly move motion control lever to desired position.

**NOTE:** The effort to move the motion control lever will reduce after the first few hours of use. This is normal.

### TO ADJUST MOWER CUTTING HEIGHT

The cutting height is controlled by turning the height adjustment knob in desired direction.

- Turn knob clockwise (C) to raise cutting height.
- Turn knob counterclockwise (D) to lower cutting height.

The cutting height range is approximately 1-1/2" to 4". The heights are measured from the ground to the blade tip with the engine not running. These heights are approximate and may vary depending upon soil conditions, height of grass and types of grass being mowed.

- The average lawn should be cut to approximately 2-1/2 inches during the cool season and to over 3 inches during hot months. For healthier and better looking lawns, mow often and after moderate growth.
- For best cutting performance, grass over 6 inches in height should be mowed twice. Make the first cut relatively high; the second to desired height.

### TO OPERATE MOWER

Your tractor is equipped with an operator presence sensing switch. Any attempt by the operator to leave the seat with the engine running and the attachment clutch engaged will shut off the engine.

- Select desired height of cut.
- Lower mower with attachment lift control.
- Start mower blades by engaging attachment clutch control.
- TO STOP MOWER BLADES - disengage attachment clutch control.

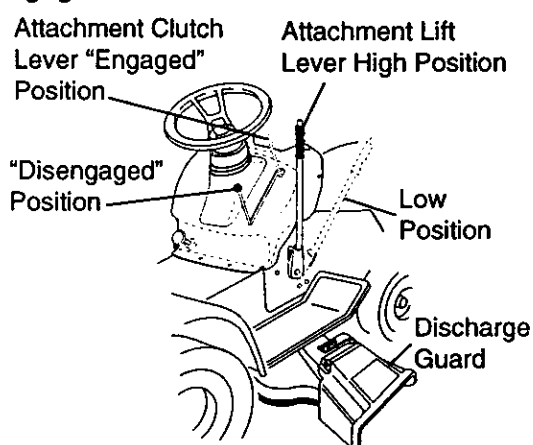

### TO OPERATE ON HILLS

**CAUTION:** Do not drive up or down hills with slopes greater than 15° and do not drive across any slope. Use the slope guide provided at the back of this manual.

- Choose the slowest speed before starting up or down hills.
- Avoid stopping or changing speed on hills.

- If slowing is necessary, move throttle control lever to slower position.
- If stopping is absolutely necessary, push clutch/brake pedal quickly to brake position and engage parking brake.
- Move motion control lever to neutral (N) position.

**IMPORTANT:** The motion control lever does not return to neutral (N) position when the clutch/brake pedal is depressed.

- To restart movement, slowly release parking brake and clutch/brake pedal.
- Slowly move motion control lever to slowest setting.
- Make all turns slowly.

### TO TRANSPORT

When pushing or towing your tractor, be sure to disengage transmission by placing freewheel control in freewheeling position. Freewheel control is located at the rear drawbar of tractor.

- Raise attachment lift to highest position with attachment lift control.
- Pull freewheel control knob out and hold in position by inserting retainer spring into forward hole of control rod.
- Do not push or tow tractor at more than two (2) MPH.
- To reengage transmission, reverse above procedure.

**NOTE:** To protect hood from damage when transporting your tractor on a truck or a trailer, be sure hood is closed and secured to tractor. Use an appropriate means of tying hood to tractor (rope, cord, etc.).

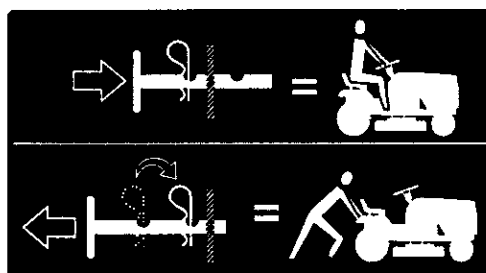

### TOWING CARTS AND OTHER ATTACHMENTS

Tow only the attachments that are recommended by and comply with specifications of the manufacturer of your tractor. Use common sense when towing. Too heavy of a load, while on a slope, is dangerous. Tires can lose traction with the ground and cause you to lose control of your tractor.

## BEFORE STARTING THE ENGINE

### CHECK ENGINE OIL LEVEL

- The engine in your tractor has been shipped, from the factory, already filled with summer weight oil.
- Check engine oil with tractor on level ground.
- Remove oil fill cap/dipstick and wipe clean, reinsert the dipstick and screw cap tight, wait for a few seconds, remove and read oil level. If necessary, add oil until "FULL" mark on dipstick is reached. Do not overfill.
- For cold weather operation you should change oil for easier starting. (See "OIL VISCOSITY CHART" in the Maintenance section of this manual).
- To change engine oil, see the Maintenance section in this manual.

### ADD GASOLINE

- Fill fuel tank. Use fresh, clean, regular unleaded gasoline with a minimum of 87 octane. (Use of leaded gasoline will increase carbon and lead oxide deposits and reduce valve life). Do not mix oil with gasoline. Purchase fuel in quantities that can be used within 30 days to assure fuel freshness.

**IMPORTANT:** When operating in temperatures below 32°F(0°C), use fresh, clean winter grade gasoline to help insure good cold weather starting.

**▲WARNING:** Experience indicates that alcohol blended fuels (called gasohol or using ethanol or methanol) can attract moisture which leads to separation and formation of acids during storage. Acidic gas can damage the fuel system of an engine while in storage. To avoid engine problems, the fuel system should be emptied before storage of 30 days or longer. Drain the gas tank, start the engine and let it run until the fuel lines and carburetor are empty. Use fresh fuel next season. See Storage Instructions for additional information. Never use engine or carburetor cleaner products in the fuel tank or permanent damage may occur.

**▲CAUTION:** Fill to bottom of gas tank filler neck. Do not overfill. Wipe off any spilled oil or fuel. Do not store, spill or use gasoline near an open flame.

### TO START ENGINE

When starting the engine for the first time or if the engine has run out of fuel, it will take extra cranking time to move fuel from the tank to the engine.

- Be sure freewheel control is in the transmission engaged position.
- Sit on seat in operating position, depress clutch/brake pedal and set parking brake.
- Place motion control lever in neutral (N) position.
- Move attachment clutch to "DISENGAGED" position.
- Move throttle control to fast position
- Pull choke control out for a cold engine start attempt. For a warm engine start attempt the choke control may not be needed.

**NOTE:** Before starting, read the warm and cold starting procedures below.

- Insert key into ignition and turn key clockwise to "START" position and release key as soon as engine starts. Do not run starter continuously for more than fifteen seconds per minute. If the engine does not start after several attempts, push choke control in, wait a few minutes and try again. If engine still does not start, pull the choke control out and retry.

### WARM WEATHER STARTING (50° F AND ABOVE)

- When engine starts, slowly push choke control in until the engine begins to run smoothly. If the engine starts to run roughly, pull the choke control out slightly for a few seconds and then continue to push the control in slowly.
- The attachments and ground drive can now be used. If the engine does not accept the load, restart the engine and allow it to warm up for one minute using the choke as described above.

### COLD WEATHER STARTING (50° F AND BELOW)

- When engine starts, slowly push choke control in until the engine begins to run smoothly. Continue to push the choke control in small steps allowing the engine to accept small changes in speed and load, until the choke control is fully in. If the engine starts to run roughly, pull the choke control out slightly for a few seconds and then continue to push the control in slowly. This may require an engine warm-up period from several seconds to several minutes, depending on the temperature.



## AUTOMATIC TRANSMISSION WARM-UP

- Before driving the unit in cold weather, the transmission should be warmed up as follows:
  - Be sure the tractor is on level ground.
  - Place the motion control lever in neutral. Release the parking brake and let the clutch/brake slowly return to operating position.
  - Allow one minute for transmission to warm up. This can be done during the engine warm up period.
- The attachments can be used during the engine warm-up period after the transmission has been warmed up and may require the choke control be pulled out slightly.

**NOTE:** A high altitude (above 3000 feet) or in cold temperatures (below 32 F) the carburetor fuel mixture may need to be adjusted for best engine performance. See "TO ADJUST CARBURETOR" in the Service and Adjustments section of this manual.

## PURGE TRANSMISSION

**▲ CAUTION:** Never engage or disengage freewheel lever while the engine is running.

To ensure proper operation and performance, it is recommended that the transmission be purged before operating tractor for the first time. This procedure will remove any trapped air inside the transmission which may have developed during shipping of your tractor.

**IMPORTANT:** Should your transmission require removal for service or replacement, it should be purged after reinstallation before operating the tractor.

- Place tractor safely on level surface with engine off and parking brake set.
- Disengage transmission by placing free-wheel control in freewheeling position (See "TO TRANSPORT" in this section of manual).
- Sitting in the tractor seat, start engine. After the engine is running, move throttle control to slow position. With motion control lever in neutral (N) position, slowly disengage clutch/brake pedal.
- Move motion control lever to full forward position and hold for five (5) seconds. Move lever to full reverse position and hold for five (5) seconds. Repeat this procedure three (3) times.

**NOTE:** During this procedure there will be no movement of drive wheels. The air is being removed from hydraulic drive system.

- Move motion control lever to neutral (N) position. Shut off engine and set parking brake.
- Engage transmission by placing free-wheel control in driving position (See "TO TRANSPORT" in this section of manual).
- Sitting in the tractor seat, start engine. After the engine is running, move throttle control to half (1/2) speed. With motion control lever in neutral (N) position, slowly disengage clutch/brake pedal.
- Slowly move motion control lever forward; after the tractor moves approximately five (5) feet, slowly move motion control lever to reverse position. After the tractor moves approximately five (5) feet return the motion control lever to the neutral (N) position. Repeat this procedure with the motion control lever three (3) times.
- Your tractor is now purged and ready for normal operation.

## MOWING TIPS

- Tire chains cannot be used when the mower housing is attached to tractor.
- Mower should be properly leveled for best mowing performance. See "TO LEVEL MOWER HOUSING" in the Service and Adjustments section of this manual.
- The left hand side of mower should be used for trimming.
- Drive so that clippings are discharged onto the area that has been cut. Have the cut area to the right of the tractor. This will result in a more even distribution of clippings and more uniform cutting.
- When mowing large areas, start by turning to the right so that clippings will discharge away from shrubs, fences, driveways, etc. After one or two rounds, mow in the opposite direction making left hand turns until finished.
- If grass is extremely tall, it should be mowed twice to reduce load and possible fire hazard from dried clippings. Make first cut relatively high; the second to the desired height.

- Do not mow grass when it is wet. Wet grass will plug mower and leave undesirable clumps. Allow grass to dry before mowing.
- **Always operate engine at full throttle when mowing** to assure better mowing performance and proper discharge of material. Regulate ground speed by selecting a low enough gear to give the mower the best cutting performance as well as the quality of cut desired.
- When operating attachments, select a ground speed that will suit the terrain and give best performance of the attachment being used.

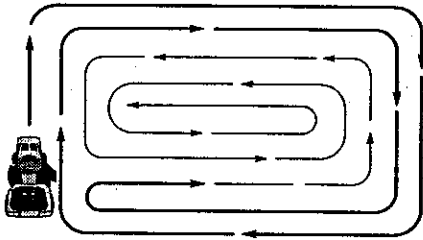

### MULCHING MOWING TIPS

**IMPORTANT:** For best performance, keep mower housing free of built-up grass and trash. Clean after each use.

- The special mulching blade will recut the grass clippings many times and reduce them in size so that as they fall onto the lawn they will disperse into the grass and not be noticed. Also, the mulched grass will biodegrade quickly to provide nutrients for the lawn. Always mulch with your highest engine (blade) speed as this will provide the best recutting action of the blades.

- Avoid cutting your lawn when it is wet. Wet grass tends to form clumps and interferes with the mulching action. The best time to mow your lawn is the early afternoon. At this time the grass has dried and the newly cut area will not be exposed to the direct sun.
- For best results, adjust the mower cutting height so that the mower cuts off only the top one-third of the grass blades. For extremely heavy mulching, reduce your width of cut on each pass and mow slowly.
- Certain types of grass and grass conditions may require that an area be mulched a second time to completely hide the clippings. When doing a second cut, mow across or perpendicular to the first cut path.
- Change your cutting pattern from week to week. Mow north to south one week then change to east to west the next week. This will help prevent matting and graining of the lawn.

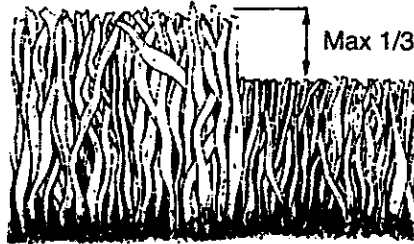

# MAINTENANCE

## CUSTOMER RESPONSIBILITIES

MAINTENANCE SCHEDULE		SERVICE DATES									
		BEFORE EACH USE	EVERY 8 HOURS	EVERY 25 HOURS	EVERY 50 HOURS	EVERY 100 HOURS	EVERY SEASON	BEFORE STORAGE			
TRACTOR	Check Brake Operation	✓	✓								
	Check Tire Pressure	✓	✓								
	Check Operator Presence and Interlock Systems	✓									
	Check for Loose Fasteners	✓				✓ <sub>7</sub>	✓				
	Sharpen/Replace Mower Blades			✓ <sub>4</sub>							
	Lubrication Chart			✓			✓				
	Check Battery Level			✓ <sub>6</sub>							
	Clean Battery and Terminals			✓			✓				
	Check Transaxle Cooling			✓							
	Adjust Blade Belt(s) Tension					✓ <sub>5</sub>					
	Adjust Motion Drive Belt(s) Tension					✓ <sub>5</sub>					
	ENGINE	Check Engine Oil Level	✓	✓							
Change Engine Oil				✓ <sub>1,2,3</sub>			✓				
Clean Air Filter				✓ <sub>2</sub>							
Clean Air Screen				✓ <sub>2</sub>							
Inspect Muffler/Spark Arrester					✓						
Replace Oil Filter (If equipped)						✓ <sub>1,2</sub>					
Clean Engine Cooling Fins						✓ <sub>2</sub>					
Replace Spark Plug						✓	✓				
Replace Air Filter Paper Cartridge						✓ <sub>2</sub>					
Replace Fuel Filter						✓					

- 1 - Change more often when operating under a heavy load or in high ambient temperatures.  
 2 - Service more often when operating in dirty or dusty conditions.  
 3 - If equipped with oil filter, change oil every 50 hours.  
 4 - Replace blades more often when mowing in sandy soil.  
 5 - If equipped with adjustable system.  
 6 - Not required if equipped with maintenance-free battery.  
 7 - Tighten front axle pivot bolt to 35 ft.-lbs. maximum. Do not overtighten.

### GENERAL RECOMMENDATIONS

The warranty on this tractor does not cover items that have been subjected to operator abuse or negligence. To receive full value from the warranty, operator must maintain tractor as instructed in this manual. Some adjustments will need to be made periodically to properly maintain your tractor. All adjustments in the Service and Adjustments section of this manual should be checked at least once each season.

- Once a year you should replace the spark plug, clean or replace air filter, and check blades and belts for wear. A new spark plug and clean air filter assure proper air-fuel mixture and help your engine run better and last longer.

### BEFORE EACH USE

- Check engine oil level.
- Check brake operation.
- Check tire pressure.
- Check operator presence and interlock systems for proper operation.
- Check for loose fasteners.

### LUBRICATION CHART

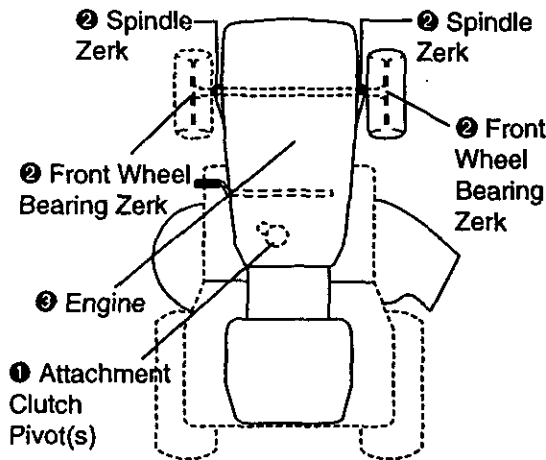

- 1 SAE 30 or 10w30 Motor OIL
- 2 General Purpose Grease
- 3 Refer to Maintenance "Engine" Section

**IMPORTANT:** Do not oil or grease the pivot points which have special nylon bearings. Viscous lubricants will attract dust and dirt that will shorten the life of the self-lubricating bearings. If you feel they must be lubricated, use only a dry, powdered graphite type lubricant sparingly.

## TRACTOR

Always observe safety rules when performing any maintenance.

## BRAKE OPERATION

If tractor requires more than six (6) feet stopping distance at high speed in highest gear, then brake must be adjusted. (See "TO ADJUST BRAKE" in the Service and Adjustments section of this manual).

## TIRES

- Maintain proper air pressure in all tires (See "PRODUCT SPECIFICATIONS" on page 3 of this manual).
- Keep tires free of gasoline, oil, or insect control chemicals which can harm rubber.
- Avoid stumps, stones, deep ruts, sharp objects and other hazards that may cause tire damage.

**NOTE:** To seal tire punctures and prevent flat tires due to slow leaks, tire sealant may be purchased from your local parts dealer. Tire sealant also prevents tire dry rot and corrosion.

## OPERATOR PRESENCE SYSTEM

Be sure that operator presence and interlock systems are working properly. If your tractor does not function as described below, repair the problem immediately.

- The engine should not start unless the clutch/brake pedal is fully depressed and attachment clutch control is in the disengaged position.
- When the engine is running, any attempt by the operator to leave the seat without first setting the parking brake should shut off the engine.
- When the engine is running and the attachment clutch is engaged, any attempt by the operator to leave the seat should shut off the engine.
- The attachment clutch should never operate unless the operator is in the seat.

## BLADE CARE

For best results mower blades must be kept sharp. Replace bent or damaged blades.

## BLADE REMOVAL

- Raise mower to highest position to allow access to blades.
- Remove hex bolt, lock washer and flat washer securing blade.
- Install new or resharpened blade with trailing edge up towards deck as shown.

**IMPORTANT:** To ensure proper assembly, center hole in blade must align with star on mandrel assembly.

- Reassemble hex bolt, lock washer and flat washer in exact order as shown.
- Tighten bolt securely (27-35 Ft. Lbs. torque).

**IMPORTANT:** Blade bolt is grade 8 heat treated.

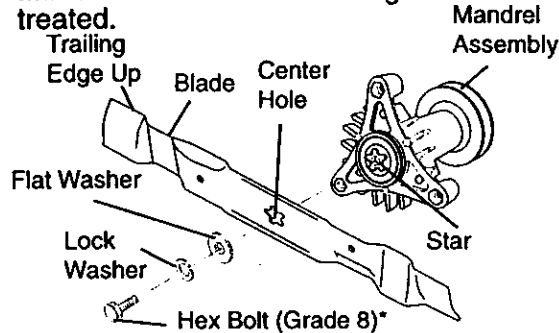

## TO SHARPEN BLADE

**NOTE:** We do not recommend sharpening blade but if you do, be sure the blade is balanced.

Care should be taken to keep the blade balanced. An unbalanced blade will cause excessive vibration and eventual damage to mower and engine.

- The blade can be sharpened with a file or on a grinding wheel. Do not attempt to sharpen while it is on the mower.
- To check blade balance, you will need a 5/8" diameter steel bolt, pin, or a cone balancer. (When using a cone balancer, follow the instructions supplied with balancer).

**NOTE:** Do not use a nail for balancing blade. The lobes of the center hole may appear to be centered, but are not.

- Slide blade onto an unthreaded portion of the steel bolt or pin and hold the bolt or pin parallel with the ground. If blade is balanced, it should remain in a horizontal position. If either end of the blade moves downward, sharpen the heavy end until the blade is balanced.

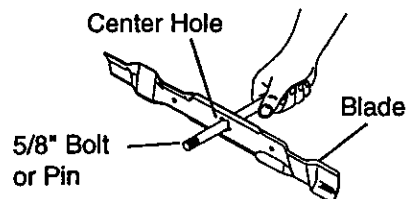

## BATTERY

Your tractor has a battery charging system which is sufficient for normal use.

However, periodic charging of the battery with an automotive charger will extend its life.

- Keep battery and terminals clean.
  - Keep battery bolts tight.
  - Keep small vent holes open.
  - Recharge at 6-10 amperes for 1 hour.
- TO CLEAN BATTERY AND TERMINALS**  
Corrosion and dirt on the battery and terminals can cause the battery to "leak" power.

- Remove terminal guard.
- Disconnect **BLACK** battery cable first then **RED** battery cable and remove battery from tractor.
- Rinse the battery with plain water and dry.
- Clean terminals and battery cable ends with wire brush until bright.
- Coat terminals with grease or petroleum jelly.
- Reinstall battery (See "REPLACING BATTERY" in the **SERVICE AND ADJUSTMENTS** section of this manual).

### V-BELTS

Check V-belts for deterioration and wear after 100 hours of operation and replace if necessary. The belts are not adjustable. Replace belts if they begin to slip from wear.

### TRANSAXLE COOLING

The transmission fan and cooling fins should be kept clean to assure proper cooling.

Do not attempt to clean fan or transmission while engine is running or while the transmission is hot.

- Inspect cooling fan to be sure fan blades are intact and clean.
- Inspect cooling fins for dirt, grass clippings and other materials. To prevent damage to seals, do not use compressed air or high pressure sprayer to clean cooling fins.

### TRANSAXLE PUMP FLUID

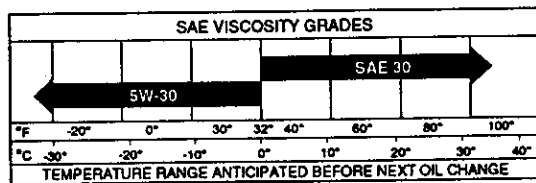

The transaxle was sealed at the factory and fluid maintenance is not required for the life of the transaxle. Should the transaxle ever leak or require servicing, contact your nearest authorized service center.

## ENGINE

### LUBRICATION

Only use high quality detergent oil rated with API service classification SF, SG or SH. Select the oil's SAE viscosity grade according to your expected operating temperature.

**NOTE:** Although multi-viscosity oils (5W30, 10W30 etc.) improve starting in cold weather, these multi-viscosity oils will result in increased oil consumption when used above 32°F. Check your engine oil level more frequently to avoid possible engine damage from running low on oil. Change the oil after every 25 hours of operation or at least once a year if the tractor is not used for 25 hours in one year.

Check the crankcase oil level before starting the engine and after each eight (8) hours of operation. Tighten oil fill cap/dipstick securely each time you check the oil level.

### TO CHANGE ENGINE OIL

Determine temperature range expected before oil change. All oil must meet API service classification SF, SG or SH.

- Be sure tractor is on level surface.
- Oil will drain more freely when warm.
- Catch oil in a suitable container.
- Remove oil fill cap/dipstick. Be careful not to allow dirt to enter the engine when changing oil.
- Remove drain plug.
- After oil has drained completely, replace oil drain plug and tighten securely.
- Refill engine with oil through oil fill dipstick tube. Pour slowly. Do not overfill. For approximate capacity see "PRODUCT SPECIFICATIONS" on page 3 of this manual.
- Use gauge on oil fill cap/dipstick for checking level. Be sure dipstick cap is tightened securely for accurate reading. Keep oil at "FULL" line on dipstick.

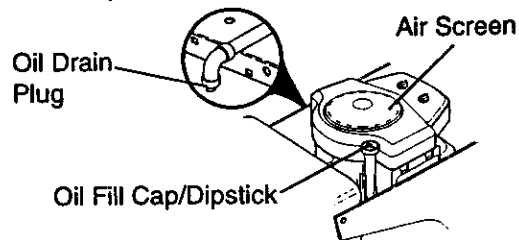

### CLEAN AIR SCREEN

Air screen must be kept free of dirt and chaff to prevent engine damage from overheating. Clean with a wire brush or compressed air to remove dirt and stubborn dried gum fibers.

## AIR FILTER

Your engine will not run properly using a dirty air filter. Clean the foam pre-cleaner after every 25 hours of operation or every season. Service paper cartridge every 100 hours of operation or every season, whichever occurs first.

Service air cleaner more often under dusty conditions.

- Remove knob(s) and cover.

### TO SERVICE PRE-CLEANER

- Slide foam pre-cleaner off cartridge.
- Wash it in liquid detergent and water.
- Squeeze it dry in a clean cloth.
- Saturate it in engine oil. Wrap it in clean, absorbent cloth and squeeze to remove excess oil.
- If very dirty or damaged, replace pre-cleaner.
- Reinstall pre-cleaner over cartridge.
- Reinstall cover and secure with knob(s).

### TO SERVICE CARTRIDGE

- Remove wing nuts and cartridge plate.
- Carefully remove cartridge to prevent debris from entering carburetor.
- Clean cartridge by tapping gently on flat surface. If very dirty or damaged, replace cartridge.
- Reinstall cartridge plate, wing nuts, pre-cleaner, cover and secure with knob(s).

**IMPORTANT:** Petroleum solvents, such as kerosene, are not to be used to clean the cartridge. They may cause deterioration of the cartridge. Do not oil cartridge. Do not use pressurized air to clean or dry cartridge.

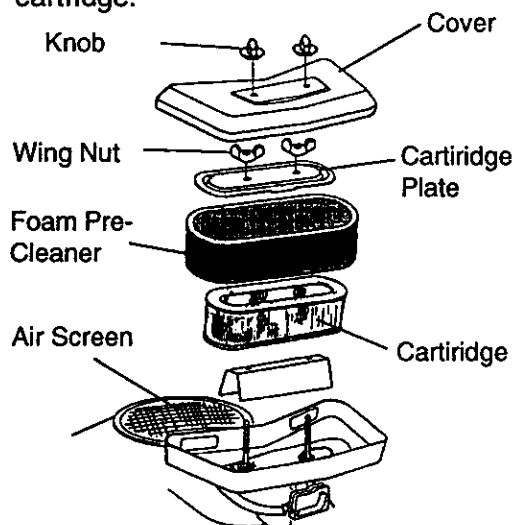

## ENGINE COOLING FINS

Remove any dust, dirt or oil from engine cooling fins to prevent engine damage from overheating. Air guide covers must be removed. Remove side panels and hood (See "TO REMOVE HOOD AND GRILL ASSEMBLY" in the Service and Adjustments section of this manual).

Top Air Guide Cover

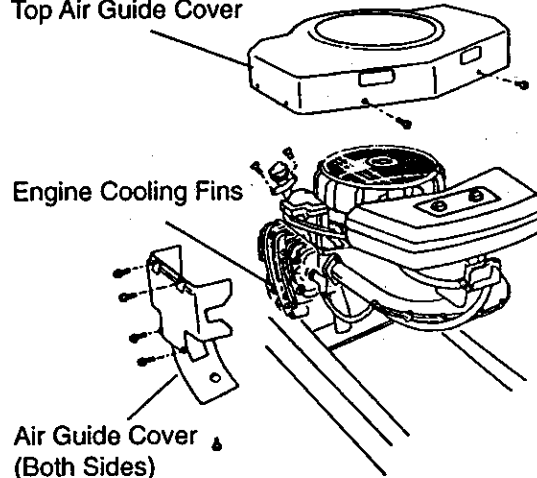

Air Guide Cover  
(Both Sides)

## MUFFLER

Inspect and replace corroded muffler and spark arrester (if equipped) as it could create a fire hazard and/or damage.

## SPARK PLUGS

Replace spark plugs at the beginning of each mowing season or after every 100 hours of operation, whichever occurs first. Spark plug type and gap setting are shown in "PRODUCT SPECIFICATIONS" on page 5 of this manual.

## IN-LINE FUEL FILTER

The fuel filter should be replaced once each season. If fuel filter becomes clogged, obstructing fuel flow to carburetor, replacement is required.

- With engine cool, remove filter and plug fuel line sections.
- Place new fuel filter in position in fuel line with arrow pointing towards carburetor.
- Be sure there are no fuel line leaks and clamps are properly positioned.

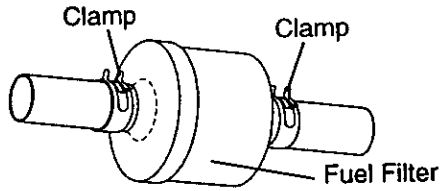

- Keep finished surfaces and wheels free of all gasoline, oil, etc.
- Protect painted surfaces with automotive type wax.

We do not recommend using a garden hose to clean your tractor unless the electrical system, muffler, air filter and carburetor are covered to keep water out. Water in engine can result in a shortened engine life.

## CLEANING

- Clean engine, battery, seat, finish, etc. of all foreign matter.

## SERVICE AND ADJUSTMENTS

### ⚠ CAUTION: Before performing any service or adjustments:

- Depress clutch/brake pedal fully and set parking brake.
- Place motion control lever in neutral (N) position.
- Place attachment clutch in "DISENGAGED" position.
- Turn ignition key "OFF" and remove key.
- Make sure the blades and all moving parts have completely stopped.
- Disconnect spark plug wire from spark plug and place wire where it cannot come in contact with plug.

## TO REMOVE MOWER

Mower will be easier to remove from the right side of tractor.

- Place attachment clutch in "DISENGAGED" position.
- Move attachment lift lever forward to lower mower to its lowest position.
- Roll belt off engine pulley.
- Disconnect clutch rod from clutch lever by removing retainer spring.
- Disconnect anti-swaybar from chassis bracket by removing retainer spring.
- Disconnect suspension arms from rear deck brackets by removing retainer springs.

- Disconnect front links from deck by removing retainer springs.
- Raise lift lever to raise suspension arms. Slide mower out from under tractor.

**IMPORTANT:** If an attachment other than the mower deck is to be mounted on the tractor, remove the front links.

## TO INSTALL MOWER

- Raise attachment lift lever to its highest position.
- Slide mower under tractor with discharge guard to right side of tractor.
- Lower lift lever to its lowest position.
- Install mower in reverse order of removal instructions.

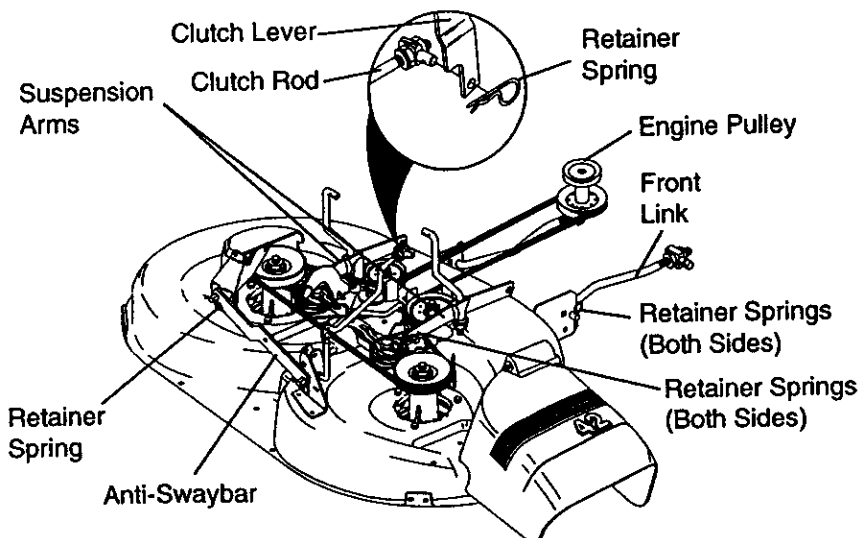

## TO LEVEL MOWER HOUSING

Adjust the mower while tractor is parked on level ground or driveway. Make sure tires are properly inflated (See "PRODUCT SPECIFICATIONS"). If tires are over or underinflated, you will not properly adjust your mower.

### SIDE-TO-SIDE ADJUSTMENT

- Raise mower to its highest position.
- At the midpoint of both sides of mower, measure height from bottom edge of mower to ground. Distance "A" on both sides of mower should be the same or within 1/4" of each other.
- If adjustment is necessary, make adjustment on one side of mower only.
- To raise one side of mower, tighten lift link adjustment nut on that side.
- To lower one side of mower, loosen lift link adjustment nut on that side.

**NOTE:** Each full turn of adjustment nut will change mower height about 1/8".

- Recheck measurements after adjusting.

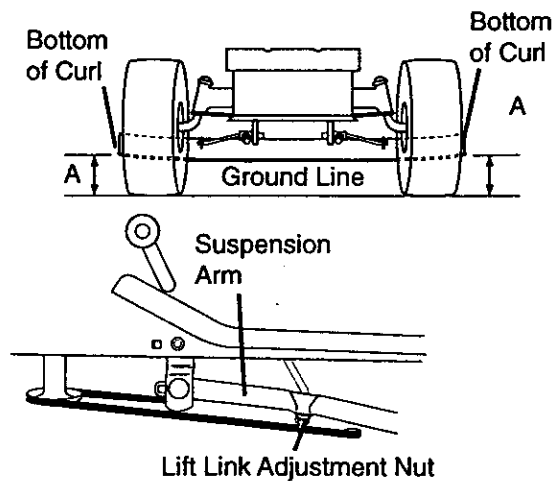

### FRONT-TO-BACK ADJUSTMENT

**IMPORTANT:** Deck must be level side-to-side. If the following front-to-back adjustment is necessary, be sure to adjust both front links equally so mower will stay level side-to-side.

To obtain the best cutting results, the mower housing should be adjusted so that the front is approximately 1/8" to 1/2" lower than the rear when the mower is in its highest position.

Check adjustment on right side of tractor. Measure distance "D" directly in front and behind the mandrel at bottom edge of mower housing as shown.

- Before making any necessary adjust-

ments, check that both front links are equal in length. Both links should be approximately 10-3/8".

- If links are not equal in length, adjust one link to same length as other link.
- To lower front of mower loosen nut "E" on both front links an equal number of turns.
- When distance "D" is 1/8" to 1/2" lower at front than rear, tighten nuts "F" against trunnion on both front links.
- To raise front of mower, loosen nut "F" from trunnion on both front links. Tighten nut "E" on both front links an equal number of turns.
- When distance "D" is 1/8" to 1/2" lower at front than rear, tighten nut "F" against trunnion on both front links.
- Recheck side-to-side adjustment.

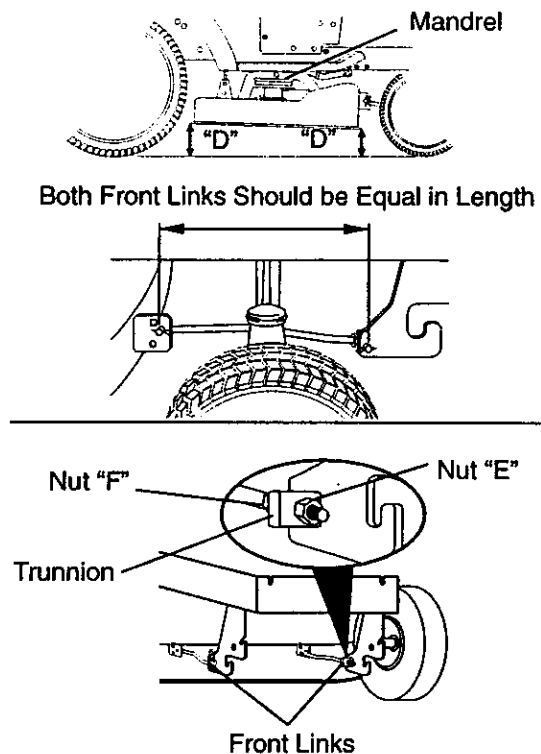

## TO REPLACE MOWER BLADE DRIVE BELT (See Illustration Next Page)

The mower blade drive belt may be replaced without tools. Park the tractor on level surface. Engage parking brake.

### BELT REMOVAL -

- Remove mower from tractor (See "TO REMOVE MOWER" in this section of this manual).
- Work belt off both mandrel pulleys and idler pulleys.
- Pull belt away from mower.



## BELT INSTALLATION -

- Install new belt in reverse order of removal.

- Make sure belt is in all pulley grooves and inside all belt guides.
- Install mower in reverse order of removal instructions.

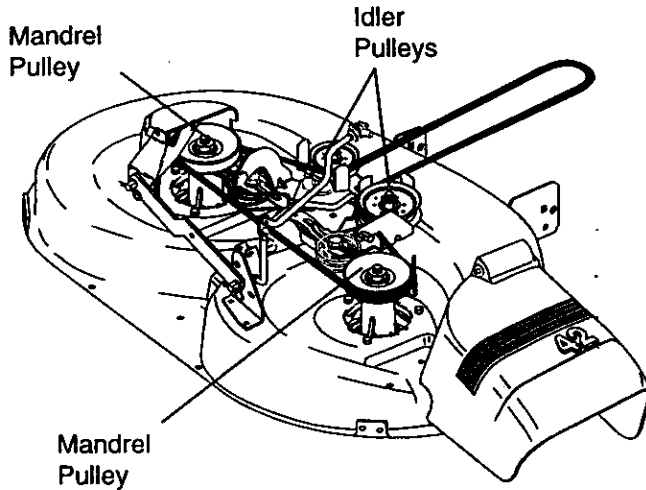

## TO ADJUST BRAKE

Your tractor is equipped with an adjustable brake system which is mounted on the side of the transaxle.

If tractor requires more than six (6) feet stopping distance at high speed in highest gear, then brake must be adjusted.

- Depress clutch/brake pedal and engage parking brake.
- Measure distance between brake operating arm and nut "A" on brake rod.
- If distance is other than 1-9/16", loosen jam nut and turn nut "A" until distance becomes 1-9/16". Retighten jam nut against nut "A".
- Road test tractor for proper stopping distance as stated above. Readjust if necessary. If stopping distance is still greater than six (6) feet in highest gear, further maintenance is necessary. Contact your nearest authorized service center/department.

## TO REPLACE MOTION DRIVE BELT

Park the tractor on level surface. Engage parking brake. For assistance, there is a belt installation guide decal on bottom side of left footrest.

- Remove mower (See "TO REMOVE MOWER" in this section of this manual.)
- Remove belt from stationary idler and clutching idler.
- Pull belt slack toward rear of tractor. Carefully remove belt upwards from transmission input pulley and over cooling fan blades.
- Pull belt toward front of tractor and remove downward from around engine pulley.
- Install new belt by reversing above procedure.

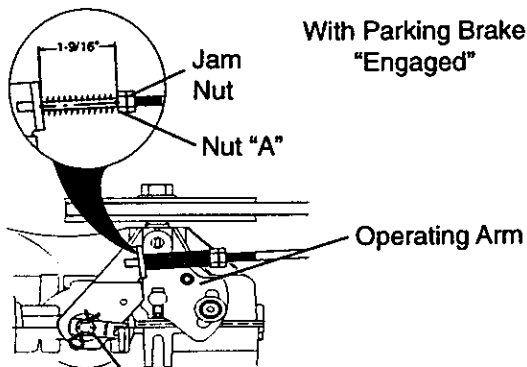
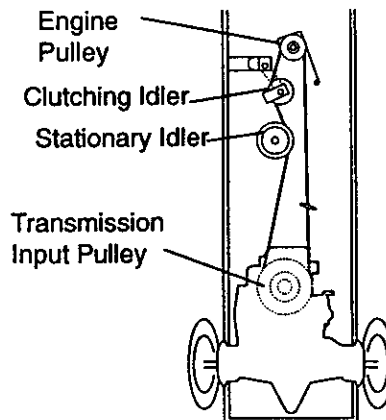

Do Not touch this nut. If further brake adjustment is necessary contact your nearest authorized service center/department

## TO ADJUST MOTION CONTROL LEVER

The motion control lever has been preset at the factory and adjustment should not be necessary.

- Loosen adjustment bolt in front of the right rear wheel, and lightly tighten.
- Start engine and move motion control lever until tractor does not move forward or backward.
- Hold motion control lever in that position and turn engine off.
- While holding motion control lever in place, loosen the adjustment bolt.
- Move motion control lever to the neutral (N) (lock gate) position.
- Tighten adjustment bolt securely.

**NOTE:** If additional clearance is needed to get to adjustment bolt, move mower deck height to the lowest position. After above adjustment is made, if the tractor still creeps forward or backward while motion control lever is in neutral position, follow these steps:

- Loosen the adjustment bolt.
- Move the motion control lever 1/4 to 1/2 inch in the direction it is trying to creep.
- Tighten adjustment bolt securely.
- Start engine and test.
- If tractor still creeps, repeat above steps until satisfied.

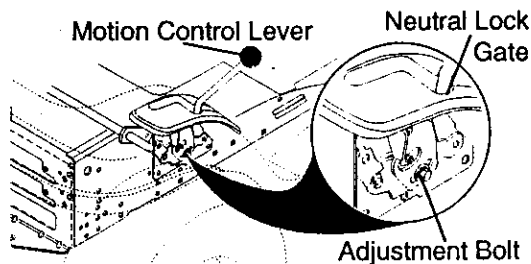

## TRANSMISSION REMOVAL/REPLACEMENT

Should your transmission require removal for service or replacement, it should be purged after reinstallation and before operating the tractor. See "PURGE TRANSMISSION" in the Operation section of this manual.

## TO ADJUST STEERING WHEEL ALIGNMENT

If steering wheel crossbars are not horizontal (left to right) when wheels are positioned straight forward, remove steering

wheel and reassemble per instructions in the Assembly section of this manual.

## FRONT WHEEL TOE-IN/CAMBER

The front wheel toe-in and camber are not adjustable on your tractor. If damage has occurred to affect the front wheel toe-in or camber, contact your nearest authorized service center.

## TO REMOVE WHEEL FOR REPAIRS

- Block up axle securely.
- Remove axle cover, retaining ring and washers to allow wheel removal (rear wheel contains a square key - Do not lose).
- Repair tire and reassemble.
- On rear wheels only: align grooves in rear wheel hub and axle. Insert square key.
- Replace washers and snap retaining ring securely in axle groove.
- Replace axle cover.

**NOTE:** To seal tire punctures and prevent flat tires due to slow leaks, tire sealant may be purchased from your local parts dealer. Tire sealant also prevents tire dry rot and corrosion.

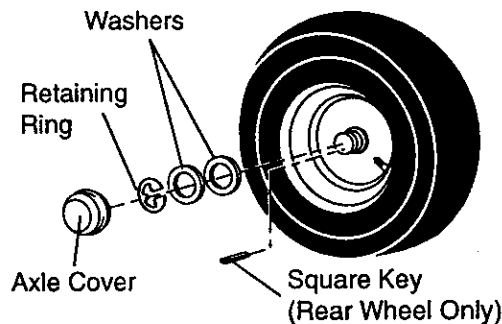

## TO START ENGINE WITH A WEAK BATTERY

**CAUTION:** Lead-acid batteries generate explosive gases. Keep sparks, flame and smoking materials away from batteries. Always wear eye protection when around batteries.

If your battery is too weak to start the engine, it should be recharged. (See "BATTERY" in the MAINTENANCE section of this manual).

If "jumper cables" are used for emergency starting, follow this procedure:

**IMPORTANT:** Your tractor is equipped with a 12 volt negative grounded system. The other vehicle must also be a 12 volt negative grounded system. Do not use your tractor battery to start other vehicles.

### TO ATTACH JUMPER CABLES -

- Connect each end of the RED cable to the POSITIVE (+) terminal of each battery, taking care not to short against chassis.
- Connect one end of the BLACK cable to the NEGATIVE (-) terminal of fully charged battery.

- Connect the other end of the BLACK cable to good CHASSIS GROUND, away from fuel tank and battery.

### TO REMOVE CABLES, REVERSE ORDER -

- BLACK cable first from chassis and then from the fully charged battery.
- RED cable last from both batteries.

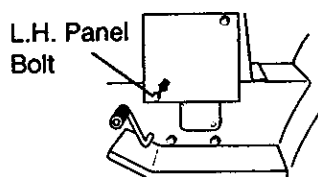
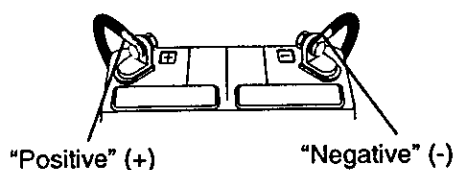

### REPLACING BATTERY

**▲CAUTION:** Do not short battery terminals by allowing a wrench or any other object to contact both terminals at the same time. Before connecting battery, remove metal bracelets, wristwatch bands, rings, etc.

Positive terminal must be connected first to prevent sparking from accidental grounding.

- Lift hood to raised position.
- Remove terminal guard.
- Disconnect BLACK battery cable then RED battery cable and carefully remove battery from tractor.
- Install new battery with terminals in same position as old battery.
- Reinstall terminal guard.
- First connect RED battery cable to positive (+) battery terminal with hex bolt and keps nut as shown. Tighten securely.
- Connect BLACK grounding cable to negative (-) battery terminal with

remaining hex bolt and keps nut.

Tighten securely.

- Close terminal access doors.
- Close hood.

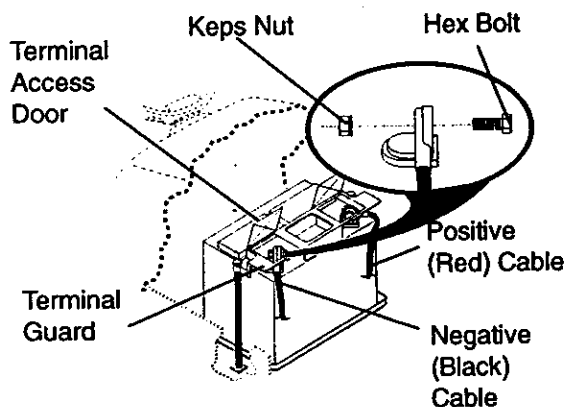

### TO REPLACE HEADLIGHT BULB

- Raise hood.
- Pull bulb holder out of the hole in the backside of the grill.
- Replace bulb in holder and push bulb holder securely back into the hole in the backside of the grill.
- Close hood.

### INTERLOCKS AND RELAYS

Loose or damaged wiring may cause your tractor to run poorly, stop running, or prevent it from starting.

- Check wiring. See electrical wiring diagram in the Repair Parts section of this manual.

### TO REPLACE FUSE

Replace with 30 amp automotive-type plug-in fuse. The fuse holder is located behind the dash.

## TO REMOVE HOOD AND GRILL ASSEMBLY

- Raise hood.
- Unsnap headlight wire connector.
- Stand in front of tractor. Grasp hood at sides, tilt toward engine and lift off of tractor.
- To replace, reverse above procedures.

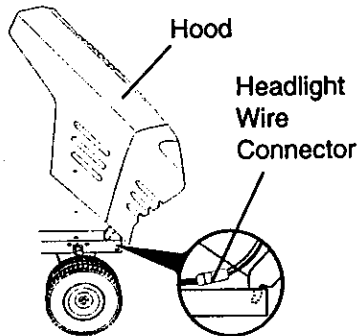

## ENGINE

Maintenance, repair, or replacement of the emission control devices and systems, which are being done at the customer's expense, may be performed by any non-road engine repair establishment or individual. Warranty repairs must be performed by an authorized engine manufacturer's service outlet.

## TO ADJUST THROTTLE CONTROL CABLE

The throttle control has been preset at the factory and adjustment should not be necessary. Check adjustment as described below before loosening cable. If adjustment is necessary, proceed as follows:

- With engine not running, move throttle control lever to fast position.
- Check that swivel is against side of quarter circle. If it is not, loosen cable clamp screw and pull cable back until swivel is against quarter circle. Tighten cable clamp screw securely.

## TO ADJUST CHOKE CONTROL

The choke control has been preset at the factory and adjustment should not be necessary. Check adjustment as described below before loosening cable. If adjustment is necessary, proceed as follows:

- With engine not running, move choke control (located on dash panel) to full choke position.
- Remove air cleaner cover, filter and cartridge plate to expose carburetor choke (see "AIR FILTER" in the Customer Responsibilities section of this manual).
- Choke should be closed. If it is not, loosen casing clamp screw and move choke cable until choke is completely closed. Tighten casing clamp screw securely.
- Reassemble air cleaner.

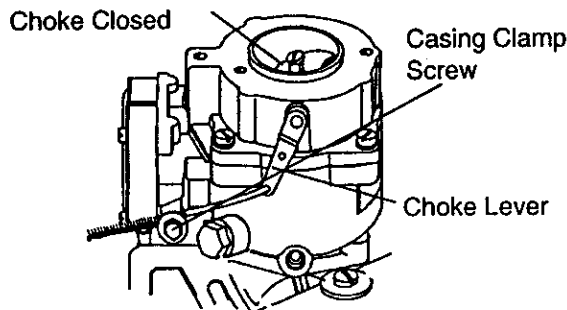
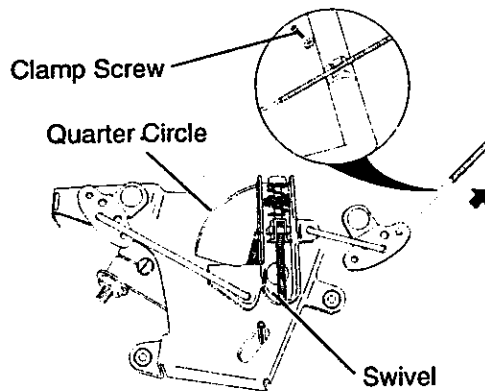

## TO ADJUST CARBURETOR

The carburetor has been preset at the factory and adjustment should not be necessary. However, minor adjustment may be required to compensate for differences in fuel, temperature, altitude or load. If the carburetor does need adjustment, proceed as follows:

In general, turning the mixture screw in (clockwise) decreases the supply of fuel to the engine giving a leaner fuel/air mixture. Turning the mixture screw out (counterclockwise) increases the supply of fuel to the engine giving a richer fuel/air mixture. **IMPORTANT:** Damage to the needles and the seats in carburetor may result if screw is turned in too tight.

## PRELIMINARY SETTING

- Be sure you have a clean air filter, and the throttle control cable and choke are adjusted properly (see above).
- With engine off turn idle mixture screw in (clockwise) closing it finger tight and then turn out (counterclockwise) 1-1/4 to 1-1/2 turns.

## FINAL SETTING

- Start engine and allow to warm for five minutes. Make final adjustments with engine running and shift/ motion control lever in neutral (N) position.
- With throttle control lever in slow position, hold throttle lever against idle speed screw and adjust idle speed screw to obtain 1200 to 1400 RPM.

- While still holding throttle lever against idle speed screw, turn idle mixture screw **in** (clockwise) until engine begins to die and then turn **out** (counterclockwise) until engine runs rough. Turn screw to a point midway between those two positions.
- Continue to hold throttle lever against idle speed screw and adjust idle speed screw to obtain 900 to 1200 RPM. Release throttle lever.

#### ACCELERATION TEST

- Move throttle control lever from slow to fast position. If engine hesitates or dies, turn idle mixture screw **out** (counterclockwise) 1/8 turn. Repeat test and continue to adjust, if necessary, until engine accelerates smoothly.

High speed stop is factory adjusted. Do not adjust - damage may result.

**IMPORTANT:** Never tamper with the engine governor, which is factory set for proper engine speed. Overspeeding the engine above the factory high speed setting can be dangerous. If you think the

engine-governed high speed needs adjusting, contact your nearest authorized service center/department, which has proper equipment and experience to make any necessary adjustments.

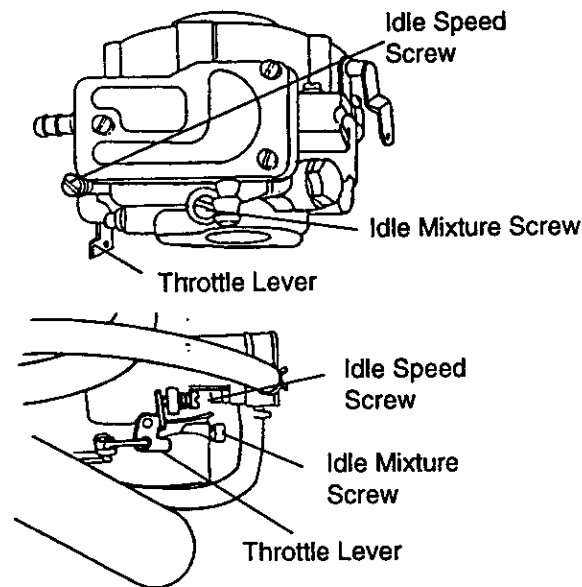

## STORAGE

Immediately prepare your tractor for storage at the end of the season or if the tractor will not be used for 30 days or more.

**CAUTION:** Never store the tractor with gasoline in the tank inside a building where fumes may reach an open flame or spark. Allow the engine to cool before storing in any enclosure.

#### TRACTOR

Remove mower from tractor for winter storage. This will allow you to clean it thoroughly. Remove all dirt, grease, leaves, etc. Store in a clean, dry area.

- Clean entire tractor (See "CLEANING" in the Maintenance section of this manual).
- Inspect and replace belts, if necessary (See belt replacement instructions in the Service and Adjustments section of this manual).
- Lubricate as shown in the Maintenance section of this manual.
- Be sure that all nuts, bolts and screws are securely fastened. Inspect moving parts for damage, breakage and wear. Replace if necessary.
- Touch up all rusted or chipped paint surfaces; sand lightly before painting.

#### BATTERY

- Fully charge the battery for storage.
- After a period of time in storage, battery may require recharging.
- To help prevent corrosion and power leakage during long periods of storage, battery cables should be disconnected and battery cleaned thoroughly (see "TO CLEAN BATTERY AND TERMINALS" in the Maintenance section of this manual).
- After cleaning, leave cables disconnected and place cables where they cannot come in contact with battery terminals.
- If battery is removed from tractor for storage, do not store battery directly on concrete or damp surfaces.

#### ENGINE

##### FUEL SYSTEM

**IMPORTANT:** It is important to prevent gum deposits from forming in essential fuel system parts such as carburetor, fuel filter, fuel hose, or tank during storage. Also, experience indicates that alcohol blended fuels (called gasohol or using ethanol or methanol) can attract moisture which leads to separation and formation of acids during storage. Acidic gas can damage the fuel system of an engine while in storage.

- Drain the fuel tank.
- Start the engine and let it run until the fuel lines and carburetor are empty.
- Never use engine or carburetor cleaner products in the fuel tank or permanent damage may occur.
- Use fresh fuel next season.

**NOTE:** Fuel stabilizer is an acceptable alternative in minimizing the formation of fuel gum deposits during storage. Add stabilizer to gasoline in fuel tank or storage container. Always follow the mix ratio found on stabilizer container. Run engine at least 10 minutes after adding stabilizer to allow the stabilizer to reach the carburetor. Do not drain the gas tank and carburetor if using fuel stabilizer.

### **ENGINE OIL**

Drain oil (with engine warm) and replace with clean engine oil. (See "ENGINE" in the Maintenance section of this manual).

### **CYLINDER(S)**

- Remove spark plug(s).
- Pour one ounce of oil through spark plug hole(s) into cylinder(s).
- Turn ignition key to "START" position for a few seconds to distribute oil.
- Replace with new spark plug(s).

### **OTHER**

- Do not store gasoline from one season to another.
- Replace your gasoline can if it starts to rust. Rust and/or dirt in your gasoline will cause problems.
- If possible, store your tractor indoors and cover it to give protection from dust and dirt.
- Cover your tractor with a suitable protective cover that does not retain moisture. Do not use plastic. Plastic cannot breathe, which allows condensation to form and cause your tractor to rust.

**IMPORTANT:** Never cover tractor while engine and exhaust areas are still warm.

## TROUBLESHOOTING CHART

PROBLEM	CAUSE	CORRECTION
Will not start	<ul style="list-style-type: none"> <li>• Out of fuel.</li> <li>• Engine not "CHOKED" properly.</li> <li>• Engine flooded.</li> <li>• Bad spark plug.</li> <li>• Dirty air filter.</li> <li>• Dirty fuel filter.</li> <li>• Water in fuel.</li> <li>• Loose or damaged wiring.</li> <li>• Carburetor out of adjustment.</li> <li>• Engine valves out of adjustment.</li> </ul>	<ul style="list-style-type: none"> <li>• Fill fuel tank.</li> <li>• See "TO START ENGINE" in Operation section.</li> <li>• Wait several minutes before attempting to start.</li> <li>• Replace spark plug.</li> <li>• Clean/replace air filter.</li> <li>• Replace fuel filter.</li> <li>• Drain fuel tank and carburetor, refill tank with fresh gasoline and replace fuel filter.</li> <li>• Check all wiring.</li> <li>• See "To Adjust Carburetor" in Service and Adjustments section.</li> <li>• Contact an authorized service center.</li> </ul>
Hard to start	<ul style="list-style-type: none"> <li>• Dirty air filter.</li> <li>• Bad spark plug.</li> <li>• Weak or dead battery.</li> <li>• Dirty fuel filter.</li> <li>• Stale or dirty fuel.</li> <li>• Loose or damaged wiring.</li> <li>• Carburetor out of adjustment.</li> <li>• Engine valves out of adjustment.</li> </ul>	<ul style="list-style-type: none"> <li>• Clean/replace air filter.</li> <li>• Replace spark plug.</li> <li>• Recharge or replace battery.</li> <li>• Replace fuel filter.</li> <li>• Drain fuel tank and refill with fresh gasoline.</li> <li>• Check all wiring.</li> <li>• See "To Adjust Carburetor" in Service and Adjustments section.</li> <li>• Contact an authorized service center.</li> </ul>
Engine will not turn over	<ul style="list-style-type: none"> <li>• Clutch/brake pedal not depressed.</li> <li>• Attachment clutch is engaged.</li> <li>• Weak or dead battery.</li> <li>• Blown fuse.</li> <li>• Corroded battery terminals.</li> <li>• Loose or damaged wiring.</li> <li>• Faulty ignition switch.</li> <li>• Faulty solenoid or starter.</li> <li>• Faulty operator presence switch(es).</li> </ul>	<ul style="list-style-type: none"> <li>• Depress clutch/brake pedal.</li> <li>• Disengage attachment clutch.</li> <li>• Recharge or replace battery.</li> <li>• Replace fuse.</li> <li>• Clean battery terminals.</li> <li>• Check all wiring.</li> <li>• Check/replace ignition switch.</li> <li>• Check/replace solenoid or starter.</li> <li>• Contact an authorized service center.</li> </ul>
Engine clicks but will not start	<ul style="list-style-type: none"> <li>• Weak or dead battery.</li> <li>• Corroded battery terminals.</li> <li>• Loose or damaged wiring.</li> <li>• Faulty solenoid or starter.</li> </ul>	<ul style="list-style-type: none"> <li>• Recharge or replace battery.</li> <li>• Clean battery terminals.</li> <li>• Check all wiring.</li> <li>• Check/replace solenoid or starter.</li> </ul>
Loss of power	<ul style="list-style-type: none"> <li>• Cutting too much grass/too fast.</li> <li>• Throttle in "CHOKE" position.</li> </ul>	<ul style="list-style-type: none"> <li>• Set in "Higher Cut" position/reduce speed.</li> <li>• Adjust throttle control.</li> </ul>

## TROUBLESHOOTING CHART

PROBLEM	CAUSE	CORRECTION
Loss of power (cont'd)	<ul style="list-style-type: none"> <li>• Build-up of grass, leaves and trash under mower.</li> <li>• Dirty air filter.</li> <li>• Low oil level/dirty oil.</li> <li>• Faulty spark plug.</li> <li>• Dirty fuel filter.</li> <li>• Stale or dirty fuel.</li> <li>• Water in fuel.</li> <li>• Spark plug wire loose.</li> <li>• Dirty engine air screen/fins.</li> <li>• Dirty/clogged muffler.</li> <li>• Loose or damaged wiring.</li> <li>• Carburetor out of adjustment.</li> <li>• Engine valves out of adjustment.</li> </ul>	<ul style="list-style-type: none"> <li>• Clean underside of mower housing.</li> <li>• Clean/replace air filter.</li> <li>• Check oil level/change oil.</li> <li>• Clean and regap or change spark plug.</li> <li>• Replace fuel filter.</li> <li>• Drain fuel tank and refill with fresh gasoline.</li> <li>• Drain fuel tank and carburetor, refill tank with fresh gasoline and replace fuel filter.</li> <li>• Connect and tighten spark plug wire.</li> <li>• Clean engine air screen/fins.</li> <li>• Clean/replace muffler.</li> <li>• Check all wiring.</li> <li>• See "To Adjust Carburetor" in Service and Adjustments section.</li> <li>• Contact an authorized service center.</li> </ul>
Excessive vibration	<ul style="list-style-type: none"> <li>• Worn, bent or loose blade.</li> <li>• Bent blade mandrel.</li> <li>• Loose/damaged part(s).</li> </ul>	<ul style="list-style-type: none"> <li>• Replace blade. Tighten blade bolt.</li> <li>• Replace blade mandrel.</li> <li>• Tighten loose part(s). Replace damaged parts.</li> </ul>
Engine continues to run when operator leaves seat with attachment clutch engaged	<ul style="list-style-type: none"> <li>• Faulty operator-safety presence control system.</li> </ul>	<ul style="list-style-type: none"> <li>• Check wiring, switches and connections. If not corrected, contact an authorized service center/department.</li> </ul>
Poor cut - uneven	<ul style="list-style-type: none"> <li>• Worn, bent or loose blade.</li> <li>• Mower deck not level.</li> <li>• Buildup of grass, leaves, and trash under mower.</li> <li>• Bent blade mandrel.</li> <li>• Clogged mower deck vent holes from buildup of grass, leaves, and trash around mandrels.</li> </ul>	<ul style="list-style-type: none"> <li>• Replace blade. Tighten blade bolt.</li> <li>• Level mower deck.</li> <li>• Clean underside of mower housing.</li> <li>• Replace blade mandrel.</li> <li>• Clean around mandrels to open vent holes.</li> </ul>
Mower blades will not rotate	<ul style="list-style-type: none"> <li>• Obstruction in clutch mechanism.</li> <li>• Worn/damaged mower drive belt.</li> <li>• Frozen idler pulley.</li> <li>• Frozen blade mandrel.</li> </ul>	<ul style="list-style-type: none"> <li>• Remove obstruction.</li> <li>• Replace mower drive belt.</li> <li>• Replace idler pulley.</li> <li>• Replace blade mandrel.</li> </ul>
Poor grass discharge	<ul style="list-style-type: none"> <li>• Engine speed too slow.</li> <li>• Travel speed too fast.</li> <li>• Wet grass.</li> </ul>	<ul style="list-style-type: none"> <li>• Place throttle control in "FAST" position.</li> <li>• Shift to slower speed.</li> <li>• Allow grass to dry before mowing.</li> </ul>



## TROUBLESHOOTING CHART

PROBLEM	CAUSE	CORRECTION
Poor grass discharge (cont'd)	<ul style="list-style-type: none"> <li>• Mower deck not level.</li> <li>• Low/uneven tire air pressure.</li> <li>• Worn, bent or loose blade.</li> <li>• Buildup of grass, leaves and trash under mower.</li> <li>• Mower drive belt worn.</li> <li>• Blades improperly installed.</li> <li>• Improper blades used.</li> <li>• Clogged mower deck vent holes from buildup of grass, leaves, and trash around mandrels.</li> </ul>	<ul style="list-style-type: none"> <li>• Level mower deck.</li> <li>• Check tires for proper air pressure.</li> <li>• Replace/sharpen blade. Tighten blade bolt.</li> <li>• Clean underside of mower housing.</li> <li>• Replace mower drive belt.</li> <li>• Reinstall blades sharp edge down.</li> <li>• Replace with blades listed in this manual.</li> <li>• Clean around mandrels to open vent holes.</li> </ul>
Headlight(s) not working (if so equipped)	<ul style="list-style-type: none"> <li>• Switch is "OFF".</li> <li>• Bulb(s) burned out.</li> <li>• Faulty light switch.</li> <li>• Loose or damaged wiring.</li> <li>• Blown fuse.</li> </ul>	<ul style="list-style-type: none"> <li>• Turn switch "ON".</li> <li>• Replace bulb(s).</li> <li>• Check/replace light switch.</li> <li>• Check wiring and connections.</li> <li>• Replace fuse.</li> </ul>
Battery will not charge	<ul style="list-style-type: none"> <li>• Bad battery cell(s).</li> <li>• Poor cable connections.</li> <li>• Faulty regulator (if so equipped).</li> <li>• Faulty alternator.</li> </ul>	<ul style="list-style-type: none"> <li>• Replace battery.</li> <li>• Check/clean all connections.</li> <li>• Replace regulator.</li> <li>• Replace alternator.</li> </ul>
Loss of drive	<ul style="list-style-type: none"> <li>• Freewheel control in "disengaged" position.</li> <li>• Motion drive belt worn, damaged or broken.</li> <li>• Air trapped in transmission during shipment or servicing.</li> </ul>	<ul style="list-style-type: none"> <li>• Place freewheel control in "engaged" position.</li> <li>• Replace motion drive belt.</li> <li>• Purge transmission.</li> </ul>
Engine "backfires" when turning engine "OFF"	<ul style="list-style-type: none"> <li>• Engine throttle control not set at "SLOW" position for 30 seconds before stopping engine.</li> </ul>	<ul style="list-style-type: none"> <li>• Move throttle control to "SLOW" position and allow to idle for 30 seconds before stopping engine.</li> </ul>

# REPAIR PARTS

TRACTOR - - MODEL NUMBER 917.270840

## ELECTRICAL

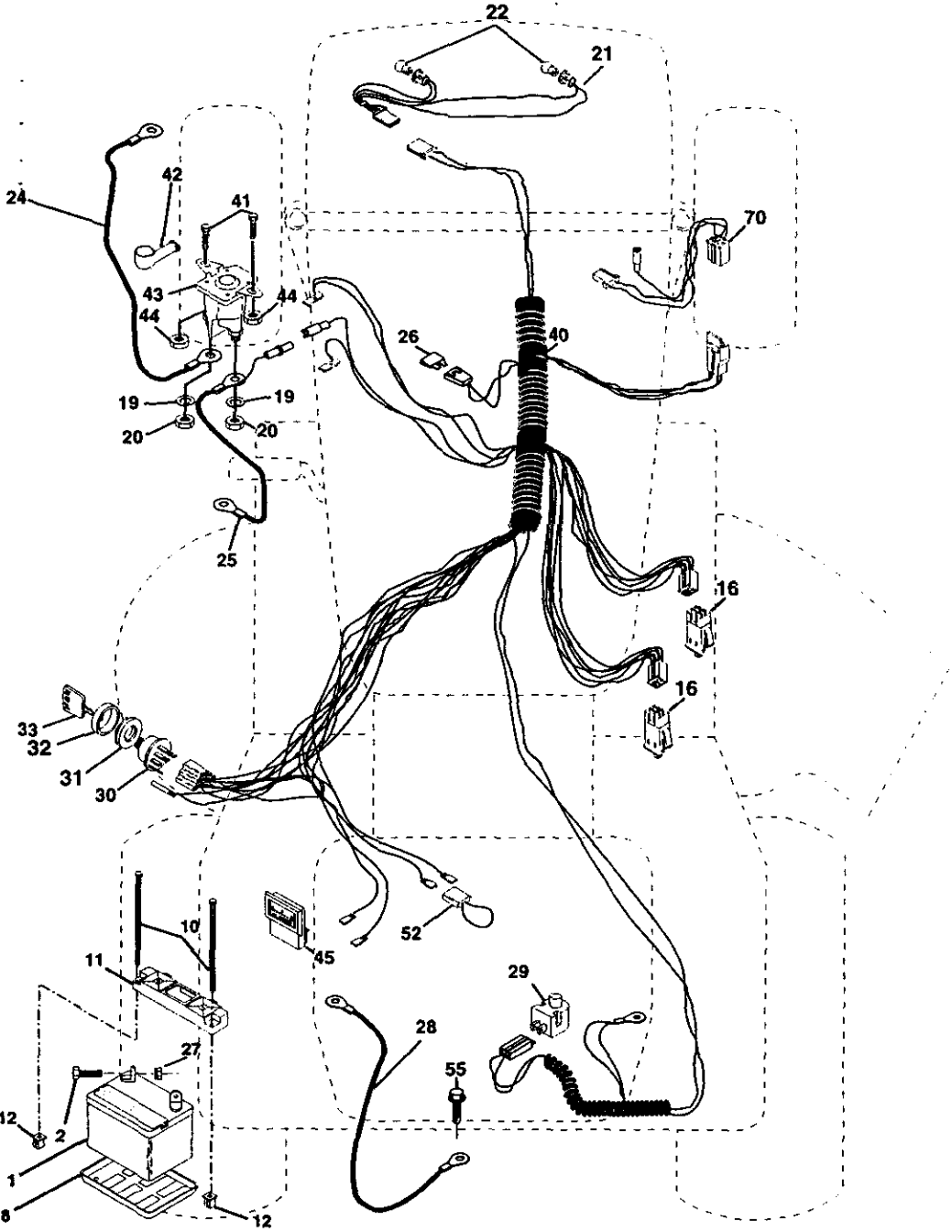

## TRACTOR -- MODEL NUMBER 917.270840

### ELECTRICAL

KEY NO.	PART NO.	DESCRIPTION
1	163465	Battery
2	74760412	Bolt, Hex 1/4-20 x 3/4
8	7603J	Tray, Battery
10	145211	Bolt, Btr Front 1/4-20 x 7-1/2
11	150109	Holddown Battery Front Mount
12	145769	Nut, Push Nylon Battery Front 1/4
16	153664	Switch Interlock Push-In
19	STD551125	Washer, Lock 1/4
20	73350400	Nut, Hex, Jam 1/4-20
21	166182	Harness, Light Socket (w/4152J)
22	4152J	Light Bulb
24	4799J	Cable, Battery
25	146148	Cable, Battery
26	166180	Fuse
27	73510400	Nut Keps Hex 1/4-20 Unc
28	145491	Cable, Ground
29	121305X	Switch, Seat
30	140301	Switch, Ignition 4 Position
31	124211X	Nut, Ignition
32	141226	Cover, Ignition Switch
33	109310X	Key, Molded, Craftsman
40	166145	Harness, Ignition
41	71110408	Bolt Blk Fin Hex 1/4-20 UNC x 1/2
42	131563	Cover, Terminal
43	168327	Solenoid
44	73640400	Nut Keps Blk Hex 1/4-20 UNC
45	121433X	Ammeter Rectangular 6 Amp
52	141940	Protection Wire Loop (Hour Meter)
55	17490508	Screw Thdrol 5/16-18 x 1/2
70	166658	Harness Engine B&S

NOTE: All component dimensions given in U.S. inches  
1 inch = 25.4 mm

**TRACTOR -- MODEL NUMBER 917.270840**  
**CHASSIS AND ENCLOSURES**

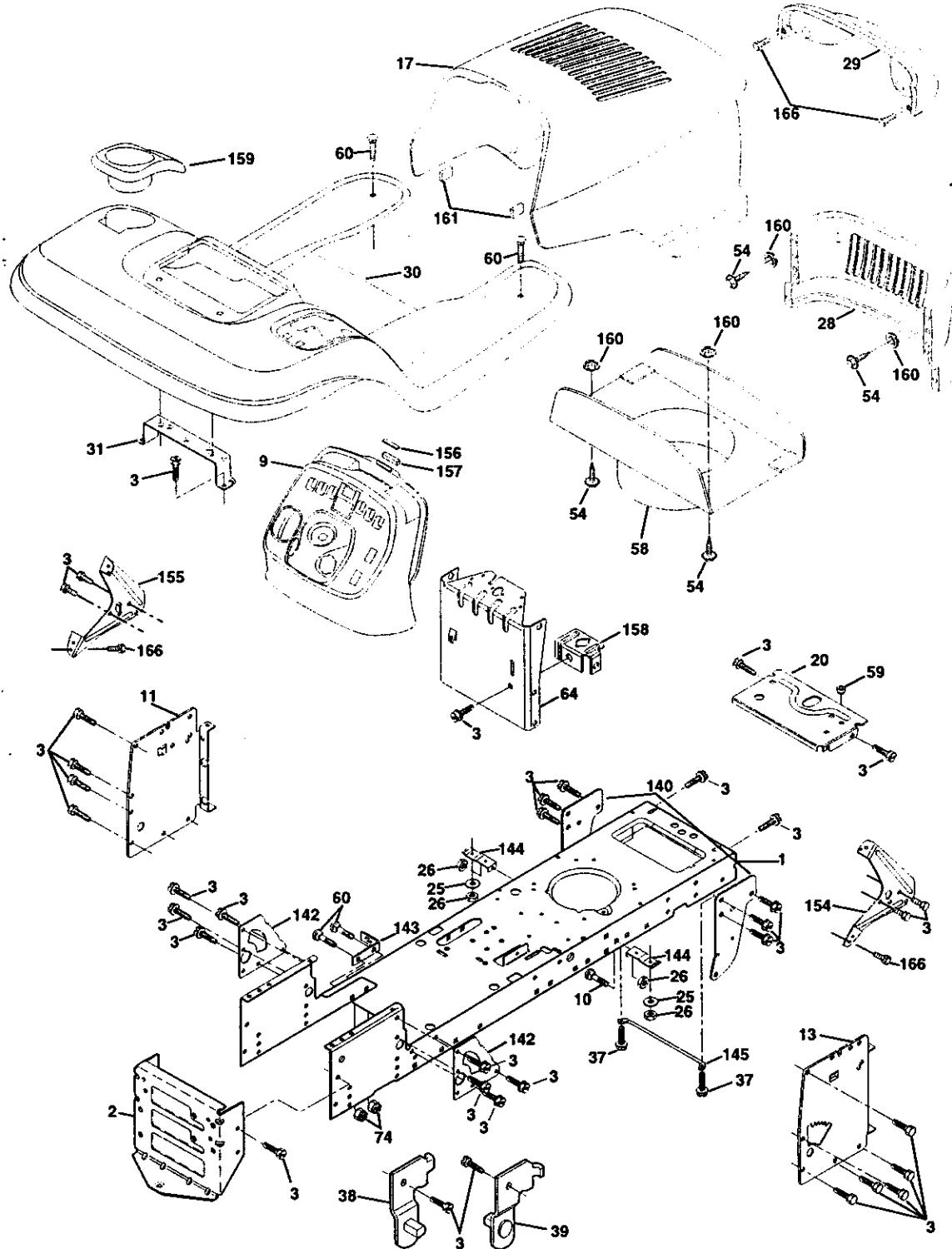

## TRACTOR - - MODEL NUMBER 917.270840

### CHASSIS AND ENCLOSURES

KEY	PART	
NO.	NO.	DESCRIPTION
1	165583	Chassis
2	140356	Drawbar
3	17490612	Screw, Thd., Roll. 3/8-16 x 3/4 Type TT
9	163976	Dash
10	STD533710	Bolt, Carriage 3/8-16 x 1
11	163455	Panel, Dash, LH
13	163456	Panel, Dash, RH
17	161023X558	Hood Assembly
20	162026	Plate Battery STYT
25	19131312	Washer 13/32 x 13/16 x 12 Gauge
26	STD541437	Locknut, Hex, with Insert 3/8-16 UNC
28	160564X558	Grille, MS-558
29	161235	Lens, Grille
30	154791X558	Fender/Footrest
31	139976	Bracket, Fender/Support
37	17490508	Screw, Thdrol. 5/16-18 x 1/2 TYT
38	139886	Pivot Bracket Assembly, LH, Mower, Rear
39	139887	Pivot Bracket Assembly, RH, Mower, Rear
54	161464	Screw Hex Wshd 8-18 x 7/8
58	161236	Duct Hood
59	110436X	Bushing, Snap, Split
60	STD533707	Bolt Rdhd Sqnk 3/8-16 UNC x 3/4
64	162025	Dash Lower STYT
74	STD541437	Nut Crownlock 3/8-16 UNC
140	158418	Bracket Suspension Front
142	165867	Plate Reinforcement STLT
143	154966	Bracket Swaybar Chassis
144	154207	Bracket Footrest STLT
145	156524	Rod Pivot Chassis/Hood
154	161897	Bracket Dash Rh
155	161900	Bracket Dash Lh
156	163805	Striker Plate
157	163806	Magnet YTG
158	162037	Parking Brake Bkrt
159	155123X428	Cupholder Stil Blk
160	162967	Fastner Nutpal
161	164655	Pinch-Welt Hood
166	164863	HWHDH:-Lo. #13-16 x 3/4

**NOTE:** All component dimensions given in U.S. inches  
1 inch = 25.4 mm

# TRACTOR -- MODEL NUMBER 917.270840

## GROUND DRIVE

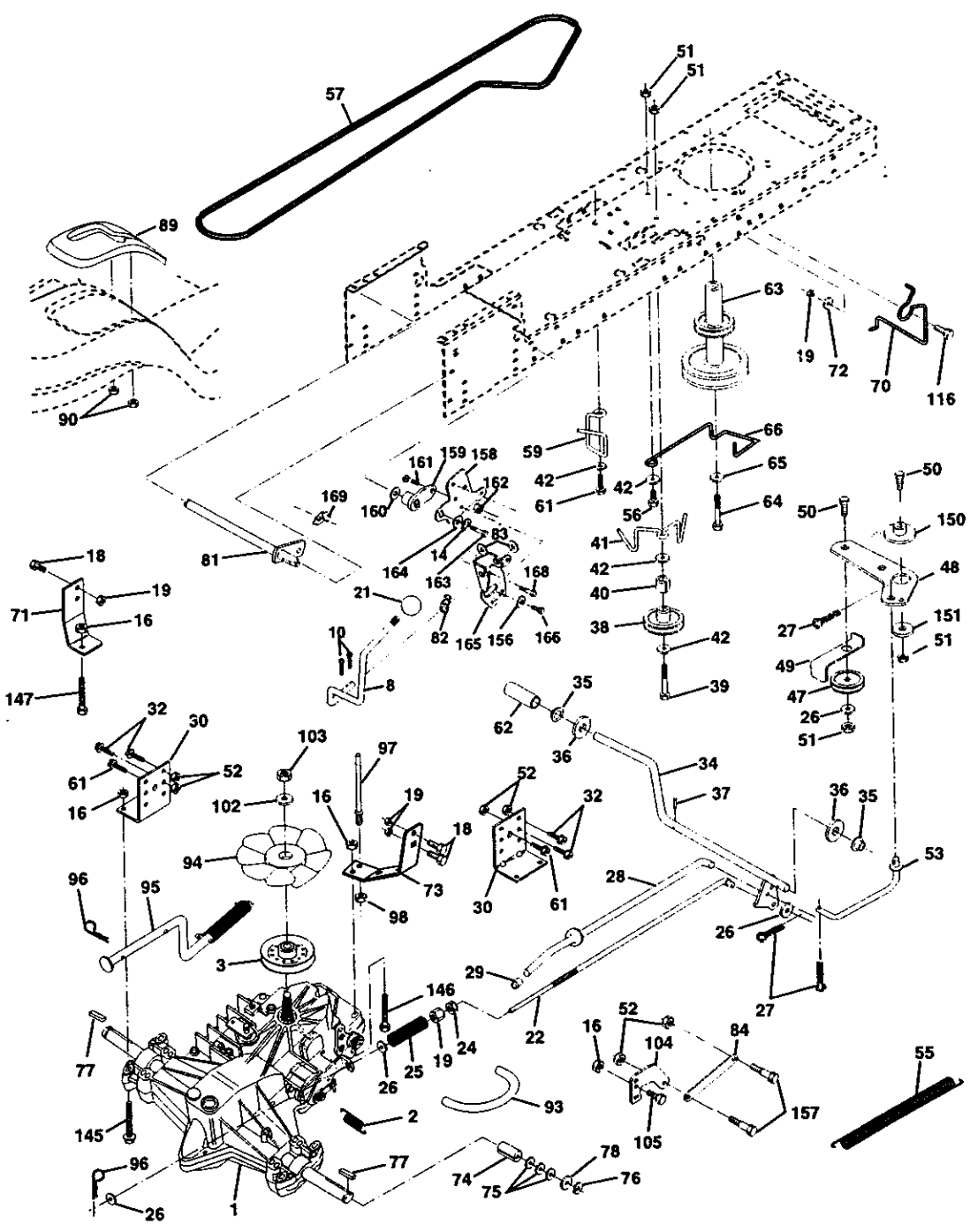

# TRACTOR - - MODEL NUMBER 917.270840

## GROUND DRIVE

KEY NO.	PART NO.	DESCRIPTION	KEY NO.	PART NO.	DESCRIPTION
1	-----	Transaxle (See Breakdown) Hydro Gr 319-0650	74	121199X	Spacer, Split
2	142431	Spring, Return, Brake	75	121749X	Washer 25/32 x 1-1/4 x 16 Gauge
3	143995	Pulley, Transaxle	76	STD581075	E-Ring
8	165866	Rod Shift Fender Adjust	77	123583X	Key, Square
10	STD561210	Pin Cotter 1/8 x 1 CAD	78	121748X	Washer 25/32 x 1-5/8 x 16 Gauge
14	10040400	Washer Lock Hvy Helical	81	165591	Shaft Asm Cross Tapered 650 20
15	74490544	Bolt Hex Flghd 5/16-18 Gr. 5	82	165711	Spring Torsion
16	STD541431	Nut Lock Hex W/Ins. 5/16-18 Unc	83	19171216	Washer 17/32 x 3/4 x 16 Ga.
18	STD523710	Bolt Fin Hex 3/8-16 Unc x 1 Gr. 5	84	165815	Link Transaxle 0650 LT/YT/STL
19	STD541437	Nut Lock Hex W/Wsh 3/8-16 Unc	86	71208	Bushing
21	130564	Knob, Deluxe 1/2-13	87	19212016	Washer 21/32 x 1-1/4 x 16 Ga.
22	145627	Rod, Brake Hydro	88	12000008	Ring Klip #5304-62
24	73350600	Nut, Hex Jam 3/8-16 Unc	89	164890X428	Console, Shift
25	106888X	Spring, Brake Rod	90	124346X	Nut Self-Thd Wsh-hd 1/4 Zinc
26	STD551037	Washer	91	74780536	Bolt Fin Hex 5/16-18 x 2-1/4
27	STD561210	Pin Cotter 1/8 x 3/4 CAD.	92	74780524	Bolt Fin Hex 5/6-18 Unc x 1-1/2
28	145204	Rod, Parking Brake	93	142564	Line Fuel Hydro 4"
29	124236X	Cap, Parking Brake	94	140462	Fan, Hydro 7"
30	130807	Bracket, Transaxle	95	144643	Control Bypass Hydro 20" Tires
32	74760512	Bolt Hex Hd 5/16-18 Unc x 3/4	96	4497H	Retainer Spring 1" Zinc/Cad
34	155071	Shaft, Foot Pedal	97	140469	Keeper Bolt Rh Hydro 0750. 18/20"
35	120183X	Bearing, Nylon	98	73510600	Nut Keps Hex 3/8-16 Unc
36	19211616	Washer	100	19111216	Washer 11/32 x 3/4 x 16 Ga.
37	1572H	Pin, Roll	102	141322	Washer Bellville .501D x 1.50D
38	131494	Pulley, Idler, Fiat	103	73940800	Nut Hex Jam Toplock 1/4-20 Unf
39	STD523727	Bolt	104	140156	Arm, Control Hydro
40	4470J	Spacer, Split	105	71070516	Screw Cap Hex 5/16 x 18 x 1
41	165838	Keeper, Belt Idler	106	74780520	Bolt Fin Hex 5/16-18 Unc x 1- 1/4
42	19131312	Washer 13/32 x 13/16 x 12 Gauge	116	72110610	Bolt Carr. 3/8-16 x 1.25
43	19111012	Washer 11/32 x 5/8 x 12 Ga.	144	19111016	Washer 11/32 x 5/8 x 16 Ga.
47	127783	Pulley, Idler, V-Groove	150	165850	Bushing Bellcrank Grd Drive
48	154407	Bellcrank Clutch Gmd Drv STL	151	19133210	Washer 13/32 x 2 x 10 Ga.
49	123205X	Retainer, Belt	156	166002	Washer Srted 5/16ID x 1.125
50	STD523715	Bolt	157	153236	Bolt Shoulder 5/16-18 Unc - 2A
51	STD541437	Nut Crownlock 3/8-16 UNC	158	165589	Bracket Shift Mount
52	STD541431	Nut, Crownlock 5/16-18 Unc	159	165494	Hub Tappered Flange Shift Lt
53	105710X	Link, Clutch	160	19292016	Washer 29/32 x 1-1/4 x 16 Ga
55	105709X	Spring, Return, Clutch	161	72140406	Bolt Rdhd Sqnk 1/4-20 x 3/4 Gr 5
56	STD523712	Bolt Hex 3/8-16 x 1-1/4	162	73680400	Nut Crownlock 1/4-20 Unc
57	140294	V-Belt, Ground Drive	163	74780416	Bolt Hex Fin 1/4-20 Unc x 1 Gr 5
59	140312	Keeper, Center Span	164	19091010	Washer 5/8 x .281 x 10 Ga
61	17490612	Screw Thdrol. 3/8-16 x 3/4 Ty. TT	165	165623	Bracket Pivot Lever
62	8883R	Cover, Pedal	166	166880	Screw 5/16-18 x 5/8
63	140186	Pulley, Engine	168	165492	Bolt Shoulder 5/16-18 x .561
64	71170764	Bolt Hex 7/16-20 x 4 Gr. 5	169	165580	Plate Fastening Lt
65	STD551143	Washer	171	17490608	Screw Thdrol 3/8-16 x 1/2 Ty-Tt
66	154778	Keeper Belt Engine Hydro			
70	134683	Guide Belt RH Engine			
71	140158	Strap Torque Lh Hydro 18/20" T			
72	19132012	Washer 13/32 x 1-1/4 x 12 Ga.			
73	156347	Strap Torque Rh Hydro 0650			

NOTE: All component dimensions given in U.S. inches  
1 inch = 25.4 mm

TRACTOR -- MODEL NUMBER 917.270840  
STEERING ASSEMBLY

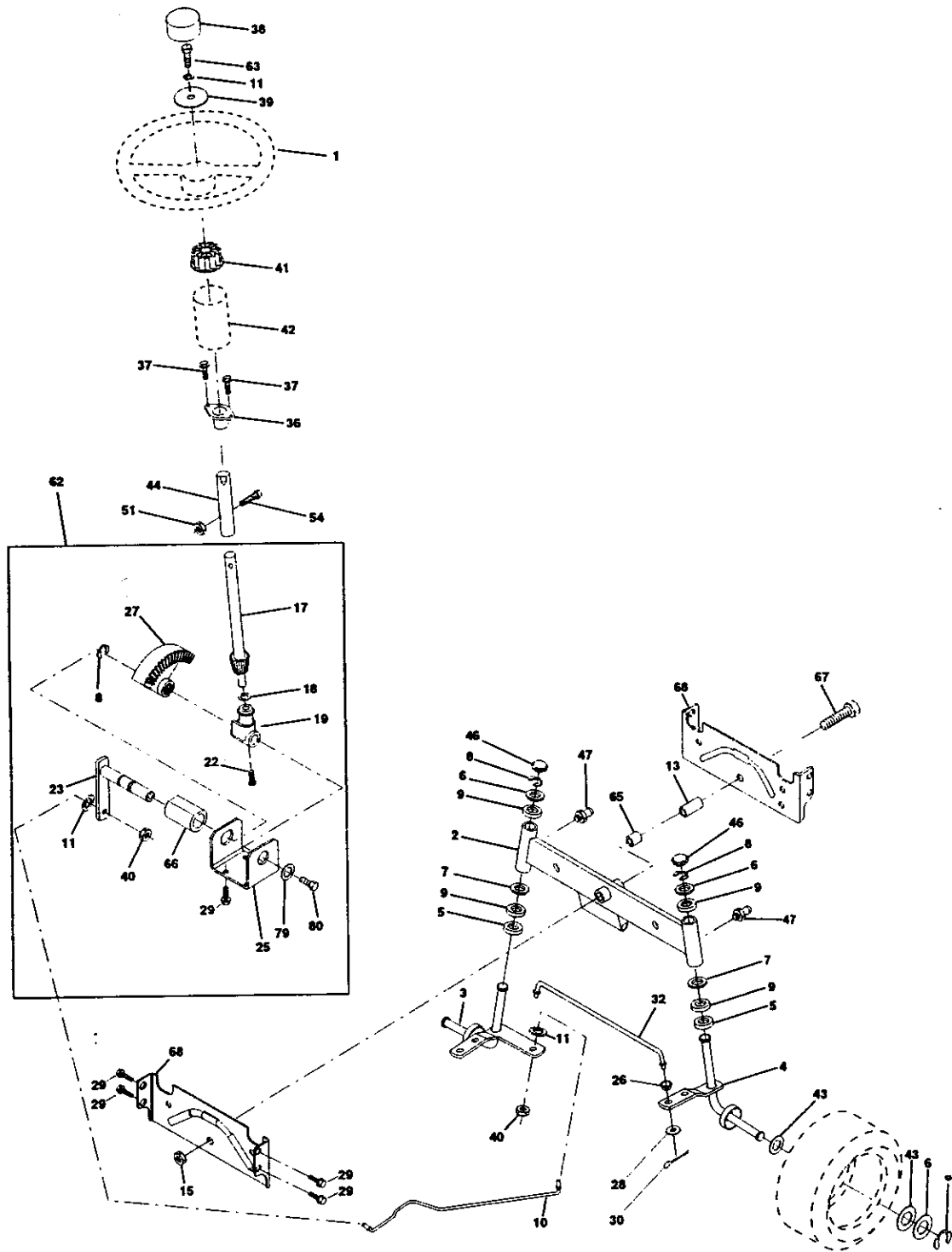



## TRACTOR - - MODEL NUMBER 917.270840

### STEERING ASSEMBLY

KEY NO.	PART NO.	DESCRIPTION
1	139768	Steering Wheel
2	154427	Front Axle Assembly
3	156483	Spindle Assembly, L.H.
4	157473	Spindle Assembly, R.H.
5	6266H	Bearing, Race, Thrust, Hardened
6	121748X	Washer 25/32 x 1-5/8 x 16 Gauge
7	19272016	Washer 27/32 x 1-1/4 x 16 Gauge
8	12000029	Ring, Klip
9	3366R	Bearing; Steering Column
10	156438	Link, Drag
11	STD551137	Washer, Lock
13	154779	Spacer, Bearing, Front Axle
15	73901000	Nut, Lock, Flange 5/8-11 UNC
17	156546	Shaft Assembly, Steering
18	57079	Washer, Thrust .515 x .750 x .033
19	160395	Support, Shaft
22	165857	Screw hex Wshhd Torx
23	165851	Pittman Shaft Assembly
25	154406	Bracket, Steering
26	126847X	Bushing, Link, Drag
27	136874	Gear, Sector
28	19131416	Washer 13/32 x 7/8 x 16 Gauge
29	17490612	Screw, Thd., Roll. 3/8-16 x 3/4
30	STD561210	Pin
32	130465	Rod, Tie
36	155099	Bushing, Steering
37	152927	Screw TT #10-32 x 5 x 3/8 Flange
38	139769	Insert, Steering Wheel
39	19133808	Washer 13/32 x 2-3/8 x 8 Gauge
40	STD541537	Gripco Nut
41	100711L	Adaptor, Steering Wheel
42	145054	Boot, Steering Dash P/L Mtl Blk
43	121749X	Washer 25/32 x 1-1/4 x 16 Gauge
44	153720	Extension Steering Non-Adjust
46	121232X	Cap, Spindle
47	6855M	Fitting, Grease
51	73800500	Nut Lock Hx W/Ins 5/16-18 UNC
54	74780520	Bolt Fin Hex 5/16-18 UNC x 1-1/4
62	156594	Kit, Steering Assembly, Service
63	74780616	Bolt Fin Hex 3/8-16 unc. x 1 Gr. 5
65	154780	Spacer Axle
66	154404	Bearing Arm Pittman
67	74781044	Bolt Fin Hex 5/8-11unc x 2-3/4
68	154429	Brace Axle
79	19132012	Washer 13/32 x 1-1/4 x 12 Ga
80	74950612	Bolt Hex Nylon 3/8-16 x 3/4

NOTE: All component dimensions given in U.S. inches  
1 inch = 25.4 mm

# TRACTOR - - MODEL NUMBER 917.270840

## ENGINE

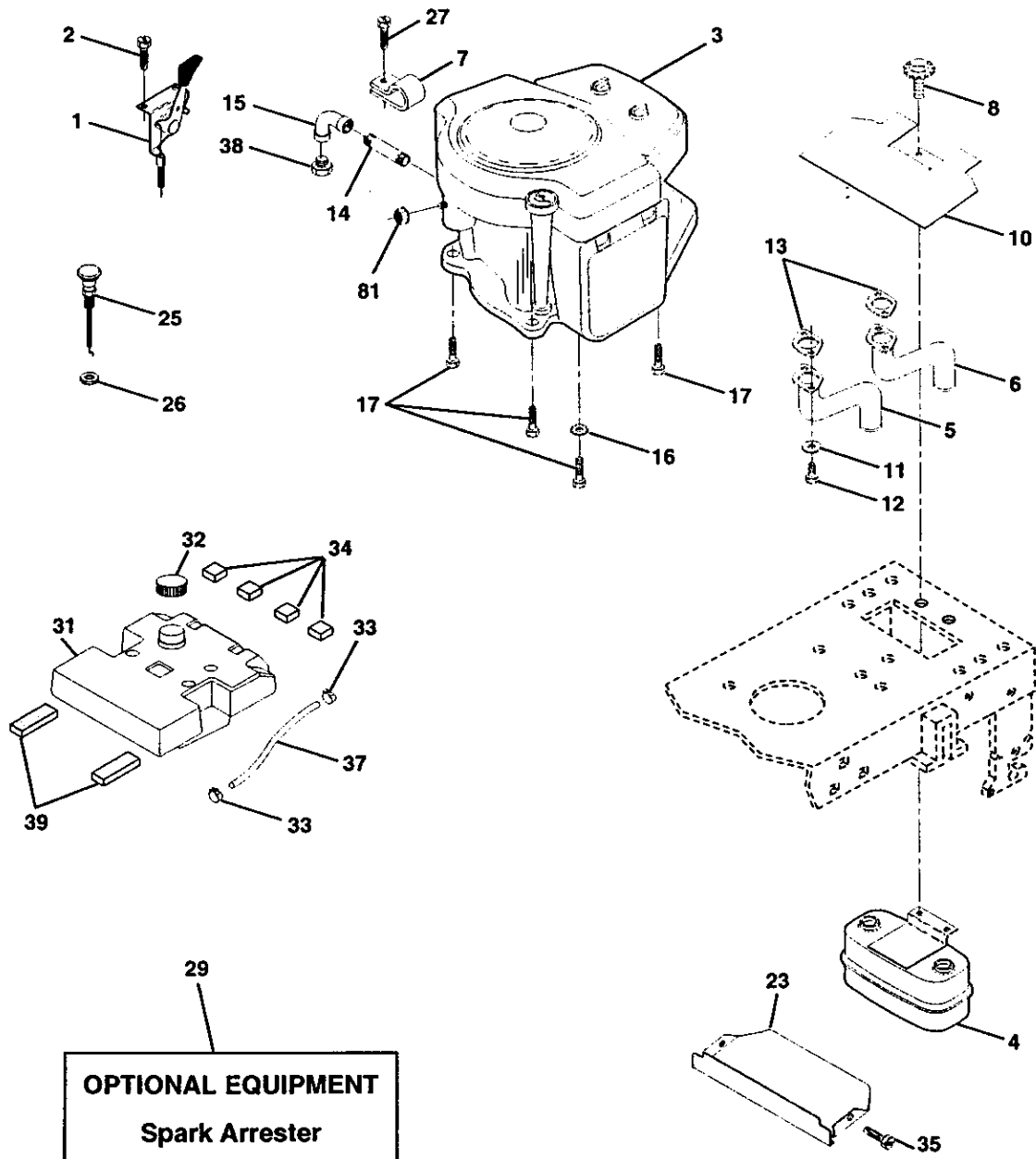

## TRACTOR - - MODEL NUMBER 917.270840

### ENGINE

KEY NO.	PART NO.	DESCRIPTION
1	162152	Control Throt Paddle 32 22
2	17720410	Screw Hex Thd Cut 1/4-20x5/8 T
3	-----	Engine (See Breakdown) Briggs Model No. 461707-0145-E1
4	149723	Muffler Exhaust
5	144069	Exhaust Asm. Left
6	144068	Exhaust Asm. Right
7	138129	Clamp Tube Double Engine
8	150176	Bolt 5/16 - 18 UNC X 3/4 W/Sems
10	145552	Heat Shield Lt
11	STD551125	Washer Lock Hvy. Helical 1/4
12	STD522507	Bolt Fin Hex 1/4-20 x 3/4
13	272250	Gasket Muffler
14	13280336	Nipple Pipe 4-1/2"
15	13200300	Elbow Std 90 Degree 3/8-18 Npt
16	STD551237	Washer Lock Ext Tooth 3/8
17	17490624	Screw Thdrol 3/8-16x1-1/2 Tytt
23	159880	Shield Browning/Debris Guard
25	145996	Control Choke
26	73920600	Nut Keps 3/8-24 Unf
27	152927	Screw TT #10-32 x 5 x 3/8 Flange
29	137180	Arrestor Spark
31	157103	Tank Fuel 3 50 Rear
32	161696	Cap Fuel Guage STLT
33	123487X	Clamp Hose Blk
34	106082X	Spacer Pad
35	17490512	Screw Thdrol 5/16-18 x 3/4 TYT
37	8543R	Line Fuel
38	-----	Plug Oil Drain (Order From Engine Manufacturer)
39	109227X	Pad Idler 1.75 x .75 x .06
40	3645J	Bushing
41	139277	Stern Tank Fuel
81	128861	Nut, Flange 1/4-20 Starter Nut

**NOTE:** All component dimensions given in U.S. inches  
1 inch = 25.4 mm

# TRACTOR -- MODEL NUMBER 917.270840

## SEAT ASSEMBLY

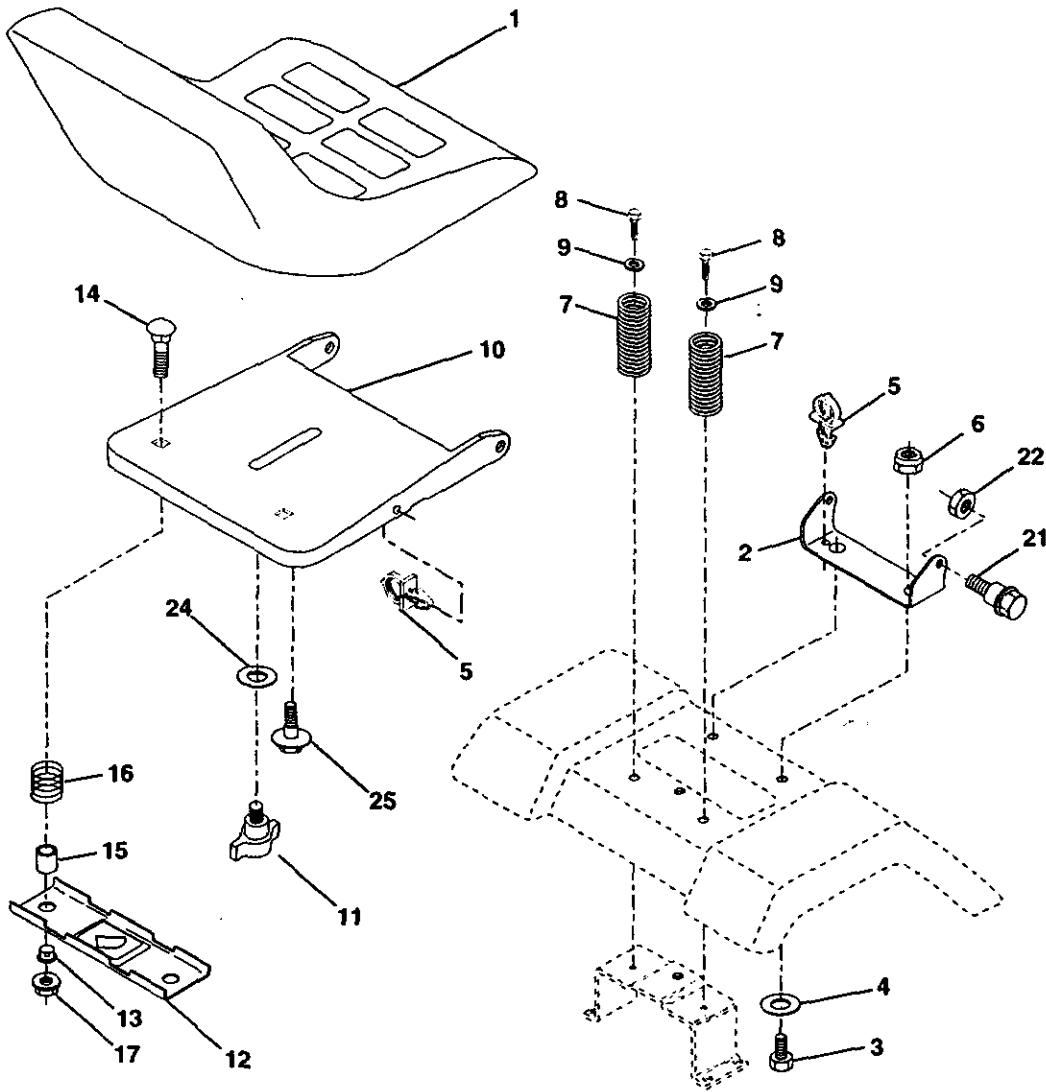

KEY NO.	PART NO.	DESCRIPTION
1	140123	Seat 3450 Blk/blk Craftsman
2	140551	Bracket Pnt Pivot Seat (blk )
3	74760616	Bolt Fin Hex 3/8-16unc X 1
4	19131610	Washer 13/32 X 3/4 X 10 Ga
5	145006	Clip Push In Hinged
6	STD541437	Nut Hex Lock w/Ins 3/8-16 Unc
7	124181X	Spring Seat Cprsn 2 250 Blk Zi
8	17490616	Screw Thdrol 3/8-16 X 1 Ty-tt
9	19131614	Washer 13/32 X 1 X 14 Ga
10	155925	Pan Pnt Seat (blk )
11	166369	Knob Seat

KEY NO.	PART NO.	DESCRIPTION
12	121246X	Bracket Pnt Mounting Switch
13	121248X	Bushing Snap Blk Nyl 50 Id
14	72050412	Bolt Rdhd Sht Nk 1/4-20x1-1/2
15	134300	Spacer Split 28 X 96 Zinc
16	121250X	Spring Cprsn 1 27 Blk Pnt
17	123976X	Nut Lock 1/4 Lge Flg Gr 5 Zinc
21	153236	Bolt Shoulder 5/16-18 Unc-2A
22	STD541431	Nut Hex Lock w/Ins 5/16-18
24	19171912	Washer 17/32 X 1-3/16 X 12 Ga.
25	127018X	Bolt Shoulder 5/16-18 X 62

**NOTE:** All component dimensions given in U.S. inches  
1 inch = 25.4 mm

# TRACTOR -- MODEL NUMBER 917.270840

## DECALS

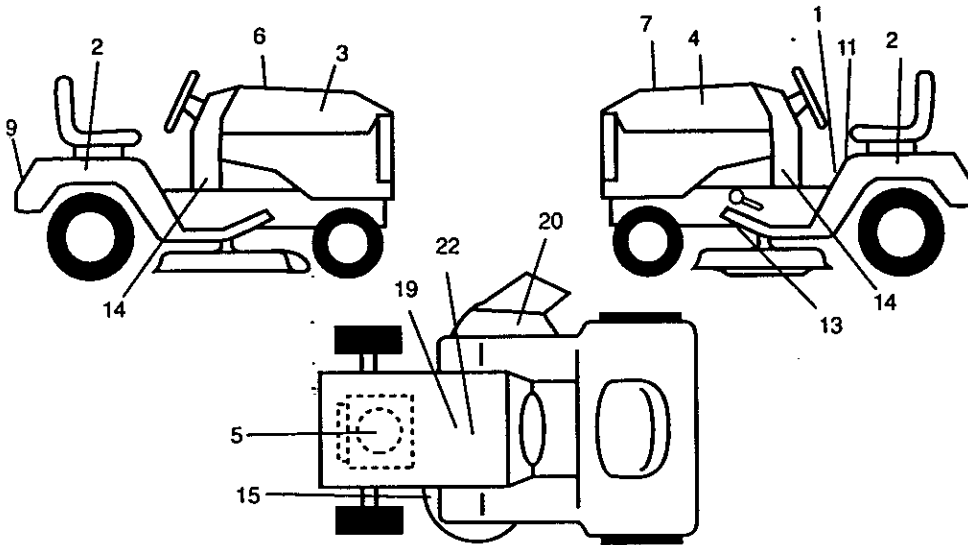

KEY NO.	PART NO.	DESCRIPTION	KEY NO.	PART NO.	DESCRIPTION
1	156439	Decal Fender Danger Sears	14	166927	Decal Dash Panel
2	163205	Decal Fend Auto Sears Gold	15	160396	Decal Mower Drive Schematic
3	163200	Decal Hood Rh Craftsman	19	138047	Decal, Battery Diehard Sears
4	163202	Decal Hood Lh Craftsman	20	166887	Decal Deck Mower EZ3
5	273503	Decal HP Engine	22	149516	Decal Battery
6	133644	Decal Maint Customer Sears Dom	--	138311	Decal Lift Handle
7	167181	Decal Replacement Srs	--	142341	Decal, Drawbar Cntrl. Mvt. Hyd. Lt.
9	163204	Decal Fender Craftsman Gold	--	154515	Pad Footrest Lh STLT
11	156811	Decal Fender STLTH Oper Inst E/S	--	154516	Pad Footrest Rh STLT
13	146046	Decal V-belt Dr.Sch Tractor E	--	166711	Manual, Owner's (English)
			--	166712	Manual, Owner's (Spanish)

## WHEELS & TIRES

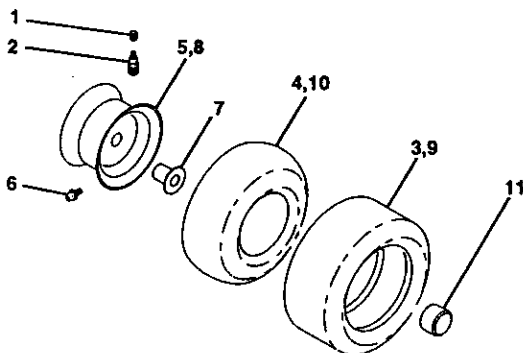

KEY NO.	PART NO.	DESCRIPTION
1	59192	Valve Cap, Tire
2	65139	Stem, Valve
3	106222X	Tire, Front
4	59904	Tube, Front Tire (Not Provided, Service Item Only)
5	106732X427	Rim, Front
6	278H	Fitting, Grease (Front Wheel Only)
7	9040H	Bearing, Flange (Front Wheel Only)
8	106108X427	Rim, Rear
9	122082X	Tire, Rear
10	7152J	Tube, Rear Tire (Not Provided, Service Item Only)
11	104757X	Cap, Axle
--	144334	Sealant, Tire (10 oz. Tube)

NOTE: All component dimensions given in U.S. inches  
1 inch = 25.4 mm

TRACTOR -- MODEL NUMBER 917.270840

LIFT ASSEMBLY

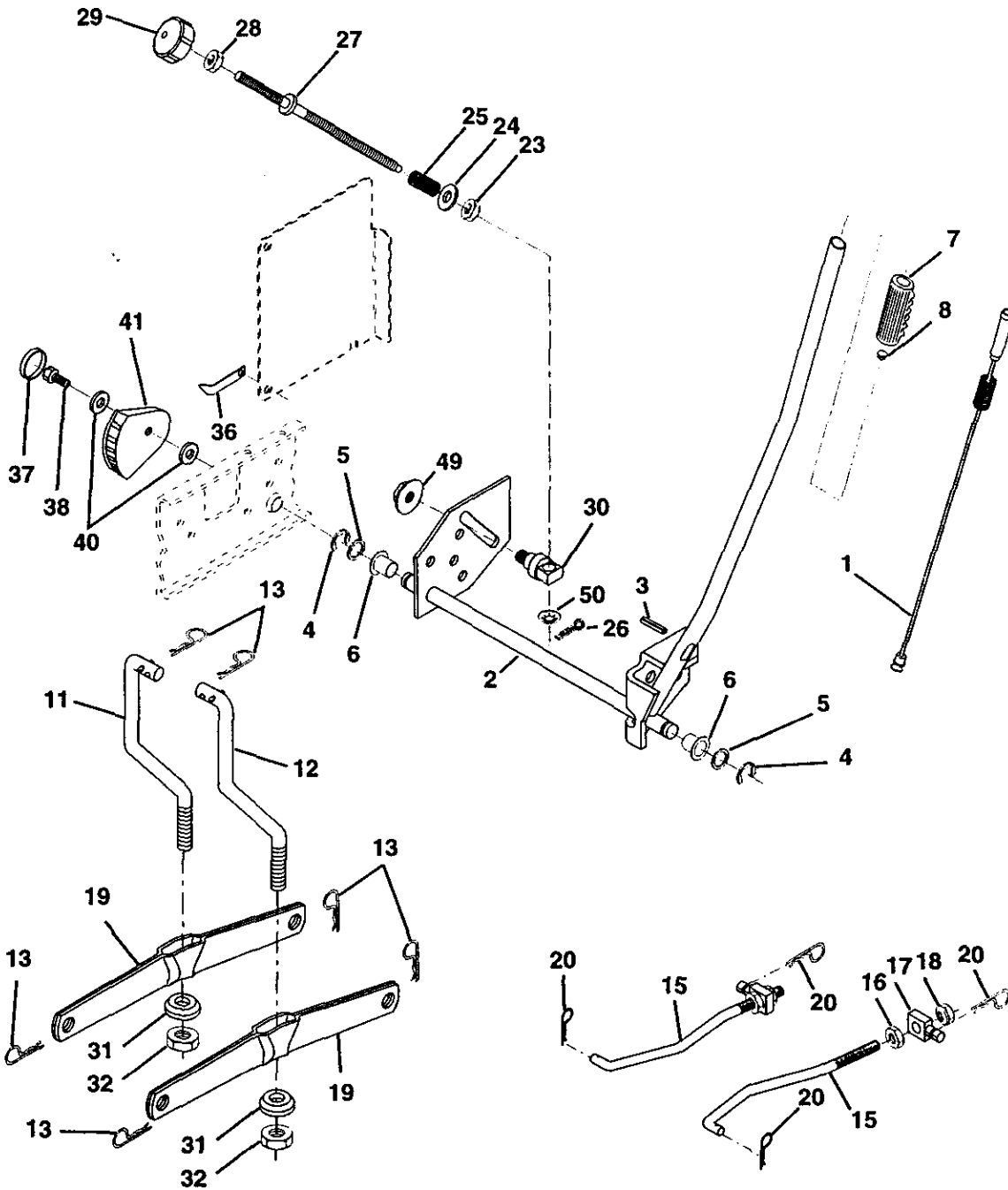

# TRACTOR - - MODEL NUMBER 917.270840

## LIFT ASSEMBLY

KEY NO.	PART NO.	DESCRIPTION
1	159460	Lift Lever Inner Wire Asm.
2	159471	Shaft Asm. Lift
3	105767X	Pin Groove
4	12000002	E Ring
5	19211621	Washer 21/32 x 1 x 21 Ga.
6	120183X	Bearing Nylon
7	125631X	Grip Handle Fluted
8	122365X	Button Plunger Read
11	139865	Link Asm Lift L.H.
12	139866	Link Asm Lift R.H.
13	STD624008	Retainer Spring
15	127218	Link Front
16	73350800	Nut Jam Hex 1/2-13 Unc
17	130171	Trunnion Blk Zinc
18	73680800	Nut Lock W/Wsh 1/2-13 Unc
19	139868	Arm Suspension Mower
20	163552	Retainer Spring
23	110807X	Nut, Special
24	19131016	Washer 13/32 x 5/8 x 16 Ga.
25	2876H	Spring
26	76020308	Pin, Cotter 3/32 x 1/2
27	126971X	Rod, Adjust Life
28	73350600	Nut, Hex Jam 3/8-16 UNC
29	138057	Knob, Infinite Height Admusement
30	150233	Trunnion, Inf. Height
31	140302	Bearing, Pvt. Lift. Spherical
32	73540600	Nut Crownlock 3/8-24
36	155097	Pointer Height Indicator
37	123935X	Plug Hole Blk 1.485/1.515 Dia
38	17490512	Screw Thdrol 5/16-18 x 3/4
40	19112410	Washer 11/32 x 1-1/2 x 10 Ga
41	155098	Indicator Height Stlt
49	145212	Nut, Hex Flange Lock
50	110452X	Nut, Push Phos. & Oil

**NOTE:** All component dimensions given in U.S. inches  
1 inch = 25.4 mm

# TRACTOR -- MODEL NUMBER 917.270840

## MOWER DECK

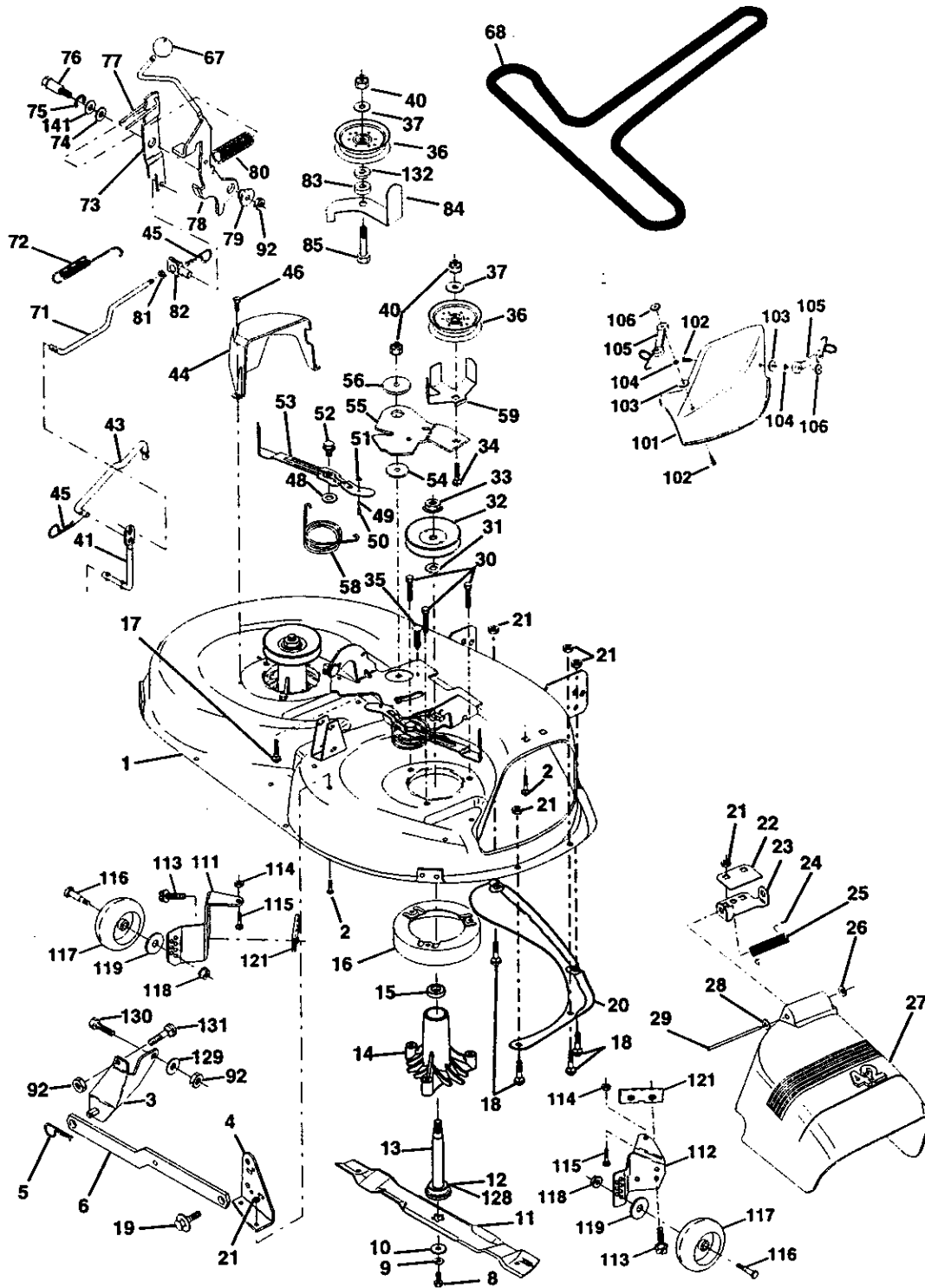



## TRACTOR - - MODEL NUMBER 917.270840

### MOWER DECK

KEY NO.	PART NO.	DESCRIPTION	KEY NO.	PART NO.	DESCRIPTION
1	164961	Mower Housing	59	141043	Guard, Tuv Idler (94)
2	STD533107	Bolt	67	162113	Knob Custom Oval
3	138017	Bracket Assembly, Sway Bar, Front	68	144200	V-Belt
4	138440	Bracket Assembly, Sway Bar	71	142427	Rod, Clutch, Primary, with Nibs
5	STD624008	Retainer Spring	72	131870	Spring, Return
6	130832	Arm, Suspension, Rear	73	127847	Arm, Clutch, Secondary
8	850857	Bolt, Hex 3/8-24 x 1.25 Gr. 8	74	121748X	Washer 25/32 x 1-5/8 x 16 Ga.
9	STD551137	Washer, Lock	75	12000029	Ring, Klip
10	140296	Washer, Hardened	76	128903	Bolt, Shoulder 3/8-16 UNC x 1.44
11	134149	Blade, Mulching	77	127845	Keeper, Spring
12	129895	Bearing, Ball	78	160570	Arm, Clutch, Primary
13	137645	Shaft Assembly, Mandrel, Vented (Incl. Key Number 6)	79	127498	Bushing, Large, Brass
14	128774	Housing, Mandrel, Vented	80	153701	Spring, Mower Clutch
15	110485X	Bearing, Ball, Mandrel	81	73350600	Nut, Hex Jam 3/8-16 UNC
16	140329	Stripper, Vented Mower Deck	82	142028	Trunnion Adj. 94
17	72110610	Bolt, Carriage 3/8-16 x 2-1/4	83	120958X	Washer Sintered
18	72140505	Bolt, Carriage 5/16-18 x 5/8	84	156084	Keeper Belt Idler
19	132827	Bolt, Shoulder	85	72140620	Bolt Carriage 3/8-16 x 2-1/2
20	159770	Baffle, Vortex	92	STD541437	Locknut, Hex W/Wsh 3/8-16 UNC
21	STD541431	Nut, Crownlock 5/16-18 UNC	101	136420	Cover Mulching 42" Black
22	134753	Stiffener Bracket	102	71161010	Screw Truss Hd Phil10-24 x5/8
23	131267	Bracket, Deflector	103	19061216	Washer #10
24	105304X	Cap, Sleeve	104	STD551110	Washer Lock
25	123713X	Spring, Torsion, Deflector	105	160793	Latch Asm Bagger
26	110452X	Nut, Push	106	2029J	Nut Weld
27	130968	Shield, Deflector	111	155197	Bracket Gauge, Wheel LH
28	19111016	Washer 11/32 x 5/8 x 16 Ga.	112	155198	Bracket, Gauge, Wheel RH
29	131491	Rod, Hinge	113	17490512	Screw Thdrol 5/16-18 x 3/4
30	157722	Screw Thdrol Rolling Wsh Hd	114	73510500	Nut, Hex Keps 5/16-18 UNC
31	129963	Washer, Spacer	115	72110504	Bolt, Carriage 5/16 UNC x 1/2
32	153535	Pulley, Mandrel	116	4898H	Bolt, Shoulder
33	137266	Nut, Toplock, Flanged	117	165746	Wheel, Gauge
34	STD533717	Bolt	118	73930600	Nut, Crownlock 3/8-16
35	133835	Fastner, Christmas Tree	119	19121414	Washer 13/32 x 7/8 x 14 Ga.
36	131494	Pulley, Idler, Flat	121	143723	Bracket
37	19131316	Washer 13/32 x 13/16 x 16 Ga.	128	153390	Washer Felt
40	STD541437	Nut, Crownlock 3/8-16 UNC	129	19131312	Washer 13/32 x 13/16 x 12 Ga.
41	133551	Rod, Pivot, with Nibs	130	STD523710	Bolt, Fin Hex 3/8-16 UNC x 1 Gr. 5
43	140083	Rod, Clutch, Secondary, w/Nibs	131	STD533710	Bolt Rdhd Sqnk 3/8-16 UNC x 1
44	140088	Guard, Mandrel, L.H.	132	19132203	Washer 13/32 x 1-3/8 x 3 Ga.
45	STD624003	Retainer	141	6266H	Washer Thrust .75 x 1.230
46	137729	Screw, Thd. Roll 1/4-20 x 5/8	--	130794	Mandrel Assembly (Includes Key Numbers 8-10, 12-15, 31 and 32)
48	133944	Washer, Hardened	--	164963	Mower Deck, Complete (Std deck - order separately mulcher plate components key nos. 101-106)
49	155066	Roller Assembly, Cam Follower			
50	131340	Bolt, Shoulder #10-24 Grade 5			
51	STD541410	Locknut			
52	139888	Bolt, Shoulder 5/16-18 UNC			
53	131845X900	Arm Assembly, Pad, Brake			
54	133943	Washer, Hardened			
55	155046	Arm, Idler			
56	122052X	Spacer, Retainer			
58	140086	Spring, Torsion Brakes 42"			

**NOTE:** All component dimensions given in U.S.inches  
1 inch = 25.4 mm

TRACTOR -- MODEL NUMBER 917.270840

HYDRO GEAR TRANSAXLE -- MODEL NUMBER 319-0650

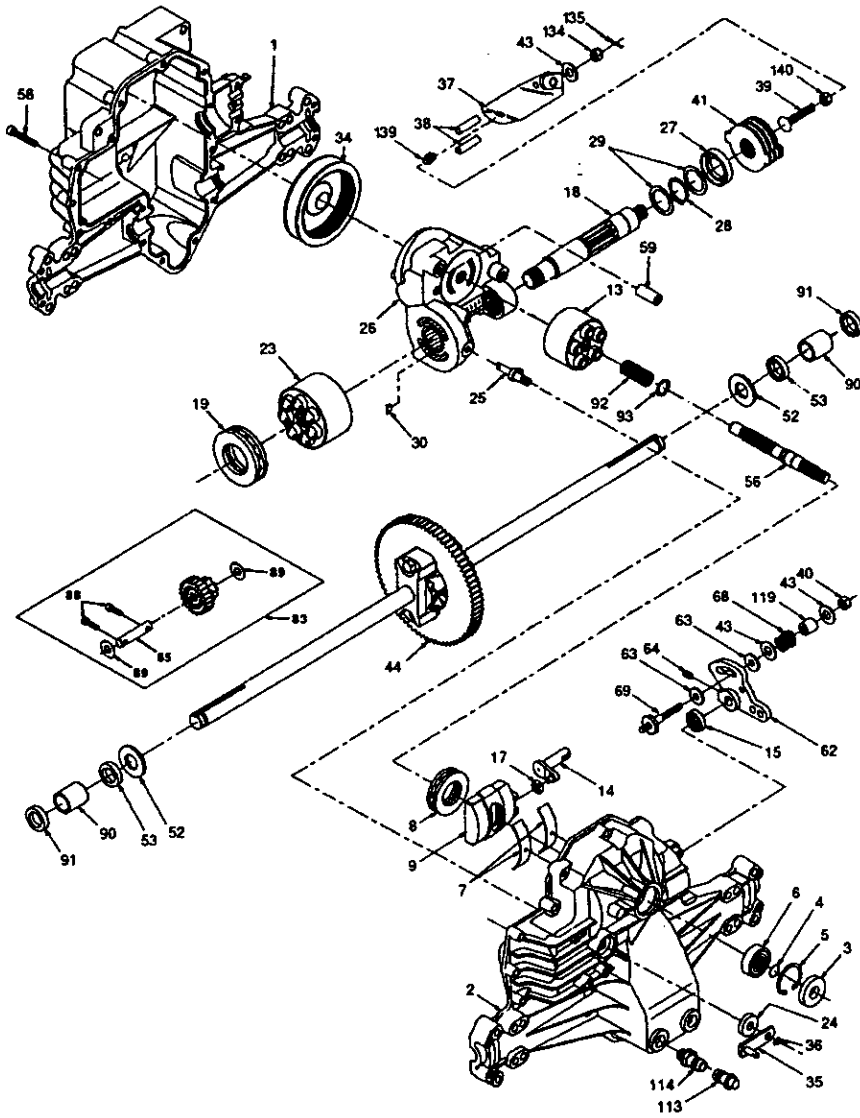

## TRACTOR - - MODEL NUMBER 917.270840

### HYDRO GEAR TRANSAXLE - - MODEL NUMBER 319-0650

KEY NO.	PART NO.	DESCRIPTION	KEY NO.	PART NO.	DESCRIPTION
1	142930	Housing, Lower	43	142884	Washer 7/16 x 7/8 x .060
2	142931	Assembly, Upper Housing	44	150829	Differential Assembly
3	142932	Seal, Lip	52	142991	Washer 3/4 x 1.5 x .13
4	142928	Ring, Wire Retaining	53	142961	Seal .75 x 1.25 x .250
5	142933	Ring, Retaining	56	142963	Shaft, Input
6	142934	Bearing, Shaft Ball	58	142964	Bolt 1/4-20 x 1.38
7	142935	Bearing, Cradle	59	142965	Pin .5 OD x .43 ID x .750
8	150771	Bearing, Thrust 30 x 52 x 13	62	142966	Arm, Control
9	142937	Swashplate, Variable	63	142967	Puck, Dampener
13	142938	Block, Cylinder Assembly	64	142920	Set Screw
14	142939	Arm, Trunnion	68	142969	Spring
15	142940	Seal, Lip	69	144610	Stud 5/16-24
17	142941	Guide, Slot	83	142971	Jackshaft Assembly
18	150772	Shaft, Motor	85	150806	Jackshaft
19	150773	Bearing, Thrust 42 x 68 x 16	88	142973	Screw, Cap
23	142944	Block, Cylinder Assembly	89	142974	Washer 7/16 x 1 x 1/2
24	142945	Seal, Lip 10 x 25 x 7	90	142975	Sleeve Bearing
25	142946	Actuator, Bypass	91	142976	Seal, Wiper
26	150774	Center Section Assembly Kit	92	142977	Spring, Block
27	142948	Seal, Lip 26 x 42 x 8	93	142978	Washer, Block Thrust
28	142949	Ring, Retaining	113	142917	Cap, Vent Assembly
29	142950	Washer 26 x 35 x 1	114	142918	Fitting, O-Ring Assembly
30	150787	Plate, Bypass	119	142980	Spacer
34	142951	Oil Filter Element	134	144607	Nut, Castle 5/16-24
35	142952	Arm, Bypass	135	144608	Pin, Cotter
36	142953	Ring, Retaining	139	150775	Spring, Compression
37	142954	Arm, Actuating	140	150776	Nut, Hex 5/16-24
38	142955	Pin, Actuating			
39	150777	Bolt 5/16-24 x 1-3/4			
40	150778	Locknut, Hex 5/16-24 UNJC			
41	142958	Brake Rotor/Stator Kit			

NOTE: All component dimensions given in U.S. inches  
1 inch = 25.4 mm

**TRACTOR - - MODEL NUMBER 917.270840**

**BRIGGS & STRATTON ENGINE-MODEL NUMBER 461707, TYPE NUMBER 0145-E1**

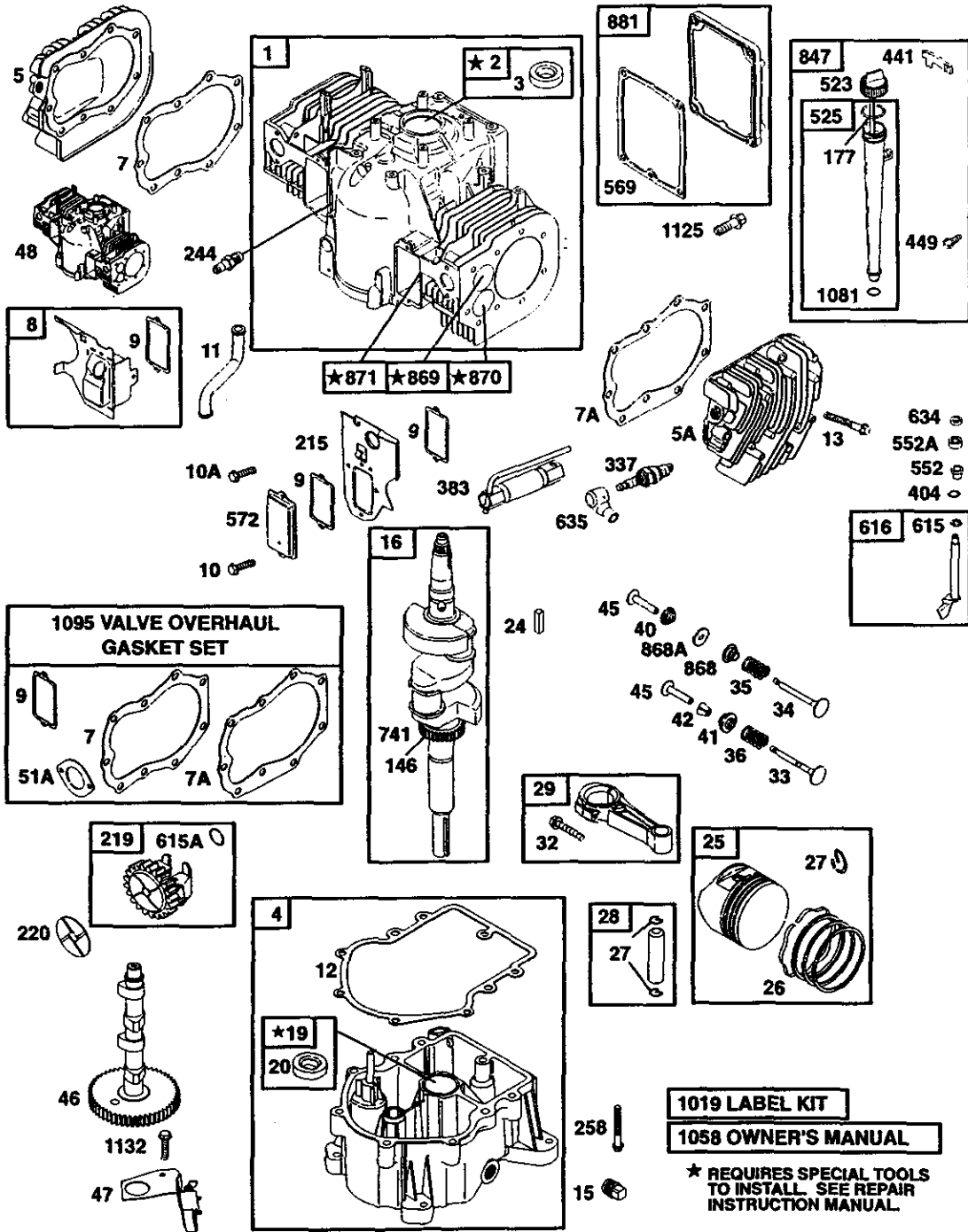

# TRACTOR - - MODEL NUMBER 917.270840

BRIGGS & STRATTON ENGINE-MODEL NUMBER 461707, TYPE NUMBER 0145-E1

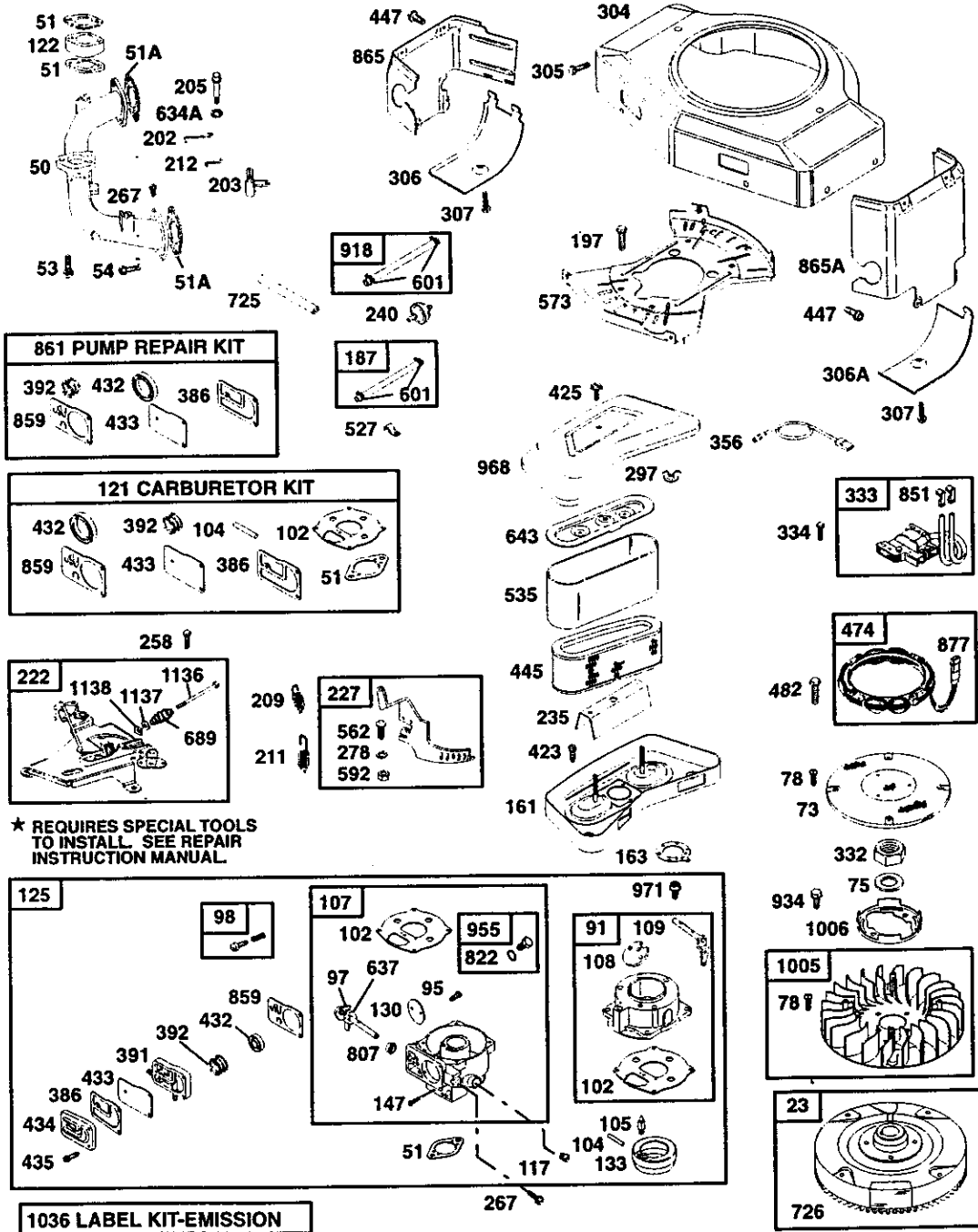

**TRACTOR -- MODEL NUMBER 917.270840**

**BRIGGS & STRATTON ENGINE-MODEL NUMBER 461707, TYPE NUMBER 0145-E1**

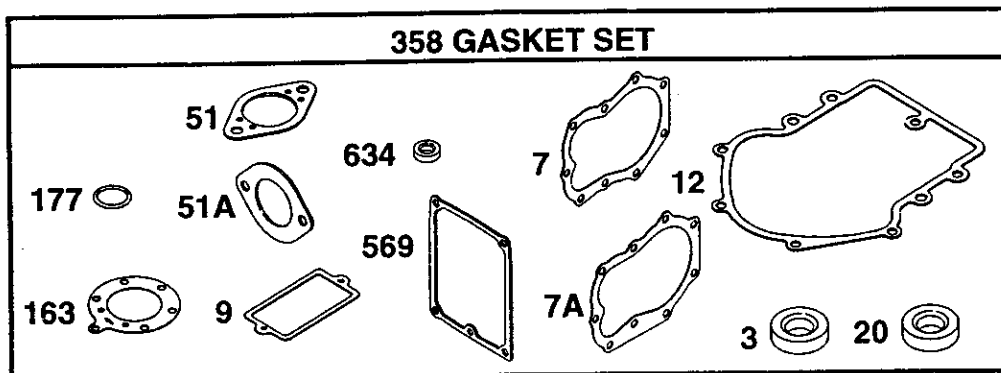
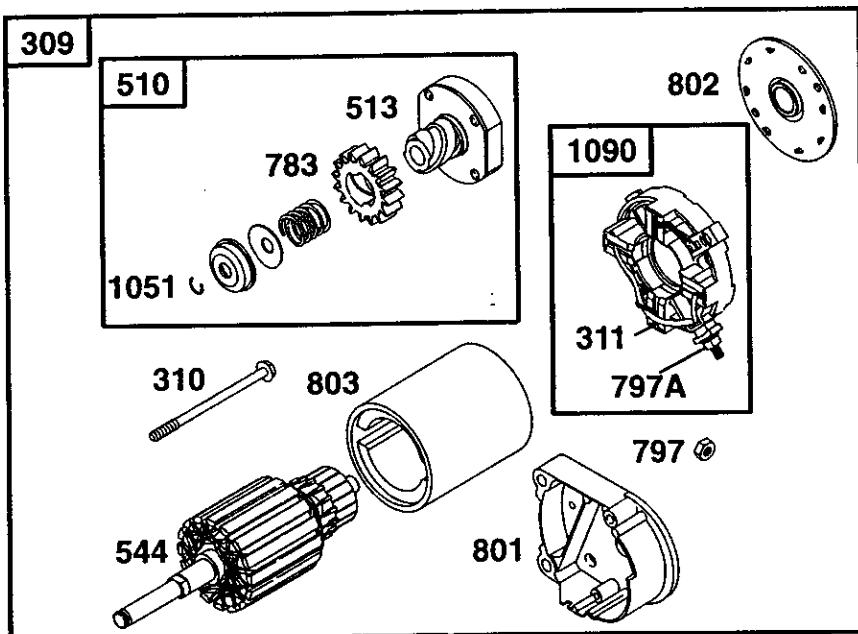

## TRACTOR - - MODEL NUMBER 917.270840

**BRIGGS & STRATTON ENGINE-MODEL NUMBER 461707, TYPE NUMBER 0145-E1**

KEY NO.	PART NO.	DESCRIPTION	KEY NO.	PART NO.	DESCRIPTION
1	498583	Cylinder Assembly	91	693483	Body Assembly-Upper
2	399265	Bushing/Seal Kit	95	690718	Screw (Throttle Valve)
3	91086	★ Seal-Oil	97	693485	Shaft-Throttle
4	493304	Sump-Engine	98	807923	Kit-Idle Speed
5	214517	Head-Cylinder #1	102	693509	● Gasket-Carburetor Body
5A	214518	Head-Cylinder #2	104	693506	● Pin-Float Hinge
7	271867	★◆ Gasket-Cylinder Head #1	105	692078	● Valve-Float Needle
7A	271868	★◆ Gasket-Cylinder Head #2	107	693482	Body Assembly-Lower
8	495754	Breather Assembly (Cylinder #1)	108	693505	Valve-Choke
			109	693498	Shaft-Choke
9	27803	★◆ Gasket-Breather	117	693538	Jet-Main
10	94382	Screw (Breather Assembly)		693500	Jet-Main (High Altitude)
10A	94380	Screw (Breather Cover)	121	491539	Carburetor Kit
11	280225	Tube-Breather	122	281411	Spacer
	273390	★ Gasket-Crankcase (.015" Thick, Std.)	125	693479	Carburetor
	271188	★ Gasket-Crankcase (.005" Thick)	130	693504	Valve-Throttle
	271189	★ Gasket-Crankcase (.009" Thick)	133	693512	Float-Carburetor
13	94565	Screw (Cylinder Head)	146	94196	Key-Timing
15	94239	Plug-Oil Drain	147	693508	Jet-Pilot
16	690666	Crankshaft	161	496599	Base-Air Cleaner
19	399264	Bushing	163	271411	★ Gasket-Air Cleaner
20	291675	★ Seal-Oil	177	271170	★ Seal-O-Ring
23	491180	Flywheel	187	299146	Line-Fuel (Cut to Required Length)
24	222698	Key-Flywheel	197	95063	Screw (Back Plate)
25	499180	Piston Assembly (Standard)	202	262683	Link-Mechanical Governor
	499181	Piston Assembly (.010" O.S.)	203	280997	Crank-Bell
	499182	Piston Assembly (.020" O.S.)	205	93971	Screw (Bell Crank)
	499183	Piston Assembly (.030" O.S.)	209	262352	Spring-Governor
26	499184	Ring Set, Piston (Standard)	211	261563	Spring-Governor
	499285	Ring Set, Piston (.010" O.S.)	212	693985	Link-Throttle
	499186	Ring Set, Piston (.020" O.S.)	215	224816	Guide-Air
	499187	Ring Set, Piston (.030" O.S.)	219	394348	Gear-Governor
27	263129	Lock-Piston Pin	220	222773	Washer-Thrust (Governor Gear)
28	498319	Pin Assembly, Piston (Std.)	222	491282	Bracket-Control
	498320	Pin Assembly-Piston (.005" O.S.)	227	491297	Lever-Governor
			235	224995	Shield-Fuel Spray
29	498314	Rod-Connecting (Standard)	240	394358	Filter-Fuel
	498541	Rod-Connecting (.020 U.S.)	244	230318	Connector-Hose (Pulse Line)
32	95017	Screw (Connecting Rod)	258	94930	Screw (Engine Sump)
33	390420	Valve-Exhaust (Include(s): Keeper-Valve (Ref. No. 42))	267	93897	Screw (Casing Clamp)
	494553		278	94942	Washer (Governor Lever)
34	691302	Valve-Intake	297	94289	Nut-Wing (Air Filter Retainer)
35	65906	Spring-Valve (Intake)	304	691390	Housing-Blower
36	26828	Spring-Valve (Exhaust)	305	690960	Screw (Blower Housing)
40	221596	Retainer-Valve (Exhaust)	306	222846	Shield-Cylinder
41	292260	Retainer-Valve (Exhaust)	306A	223734	Shield-Cylinder
42	494553	Keeper-Valve	307	94930	Screw (Cylinder Shield)
45	261368	Tappet-Valve	309	497596	Motor-Starter
46	214487	Camshaft	310	94003	Bolt (Starter Motor)
47	393415	Slinger-Oil	311	497608	Brush Set
48	498542	Short Block	332	230674	Nut (Flywheel)
50	213290	Manifold-Intake	333	394891	Armature-Magneto
51	271412	★● Gasket-Intake	334	94731	Screw (Magneto Armature)
51A	270884	★◆ Gasket-Intake	337	802592	Plug-Spark
53	93970	Screw (Carburetor)	356	494705	Wire-Stop
54	93208	Screw (Intake Manifold)	358	495868	Gasket Set
73	691438	Screen-Rotating	383	89838	Wrench-Spark Plug
75	222511	Washer (Flywheel)	386	693490	●+ Gasket-Pump
78	691134	Screw (Flywheel Fan)	391	693487	Body-Pump

## TRACTOR - - MODEL NUMBER 917.270840

**BRIGGS & STRATTON ENGINE-MODEL NUMBER 461707, TYPE NUMBER 0145-E1**

KEY NO.	PART NO.	DESCRIPTION	KEY NO.	PART NO.	DESCRIPTION
392	693491	●+ Spring-Pump Diaphragm	871	261961	Bushing-Guide (Exhaust)
404	223882	Washer (Governor Crank)		231218	Bushing-Guide (Intake)
423	94674	Screw (Air Cleaner Base)	877	393456	Wire-Alternator
425	94823	Screw (Air Cleaner Cover)	881	495901	Plate-Cover
432	693492	●+ Cap-Spring	918	393815	Hose-Vacuum (Cylinder-To-Impulse Pump)(Cut to Required Length)
433	693489	●+ Diaphragm-Fuel Pump			
434	693493	Cover-Diaphragm	934	94627	Screw (Fan Retainer)
435	693494	Screw (Diaphragm Cover)	955	693513	Plug-Carburetor
441	222875	Bracket-Oil Fill	968	225008	Cover-Air Cleaner
445	394019	Filter-Air	971	805540	Screw (Upper Body To Lower Body)
447	93343	Screw (Air Guide Cover)			
449	94882	Screw (Oil Fill Bracket)	1005	498157	Fan-Flywheel
474	93474	Alternator	1006	224901	Retainer-Fan
482	93621	Screw (Alternator)	1019	496726	Label Kit
510	497606	Drive-Starter	1036	499382	Label Kit-Emission
513	398003	Clutch-Drive	1051	263080	Ring-Retaining
523	494947	Dipstick	1058	273688	Owner's Manual
525	495348	Tube-Oil Fill	1081	280860	★ Seal-O-Ring
527	223167	Clamp-Tube	1090	497605	Retainer-Brush
535	272490	Filter-Air	1095	498047	Gasket Set-Valve Overhaul
544	97603	Armature-Starter	1125	94724	Screw (Cover Plate)
552	262332	Bushing (Governor Crank)	1132	94675	Screw (Oil Slinger)
552A	262331	Bushing (Governor Crank)	1136	94297	Screw (Governor, Control Rod)
562	93853	Bolt-Carriage (Governor Lever)	1137	220680	Washer (Governor, Control Rod)
569	272645	★ Gasket-Base			
572	222892	Cover-Breather (Cylinder #2)	1138	94298	Nut (Governor, Control Rod)
573	491304	Plate-Back	--	460707-0145-E1	Replacement Engine
592	92278	Nut (Governor Lever)			
601	95162	Clamp-Hose			
615	94296	Retainer (Governor Crank)	★		Included in Gasket Set, Ref Number 358.
615A	93898	Retainer-Governor Shaft	●		Included in Carburetor Kit, Ref Number 121.
616	491530	Crank-Governor	◆		Included in Valve Overhaul Kit, Ref Number 1095.
634	491287	★ Seal-Governor Shaft	+		Included in Fuel Pump Kit, Ref Number 861
634A	271013	Washer-Foam	★ ●◆+		
635	66538	Boot-Spark Plug			
637	693510	Washer-Seal			
643	496700	Retainer-Air Filter			
689	262337	Spring-Friction			
697	93585	Screw (Drive Cap)			
725	280866	Shield-Heat			
726	91362	Gear-Ring			
741	262989	Gear-Timing			
783	693059	Gear-Starter			
797	94010	Nut (Starter Terminal)			
797A	693167	Nut (Starter Terminal)			
801	394860	Cap-Drive			
802	497607	Cap-End			
803	497604	Housing-Starter			
807	693511	Spacer			
822	693497	Washer-Seal (Throttle Shaft)			
847	495715	Dipstick/Tube Assembly			
851	493880	Terminal-Cable			
859	693488	●+ Diaphragm-Fuel Pump			
861	393397	Kit-Fuel Pump			
865	224774	Cover-Air Guide			
865A	224775	•Cover-Air Guide			
868	497656	Seal-Valve			
868A	273312	Seal-Valve			
869	261463	Seat-Valve (Intake)			
870	262924	Seat-Valve (Exhaust)			

NOTE: All component dimensions given in U.S. inches  
1 inch = 25.4 mm



# TRACTOR -- MODEL NUMBER 917.270840

## SCHEMATIC

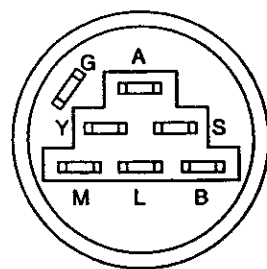
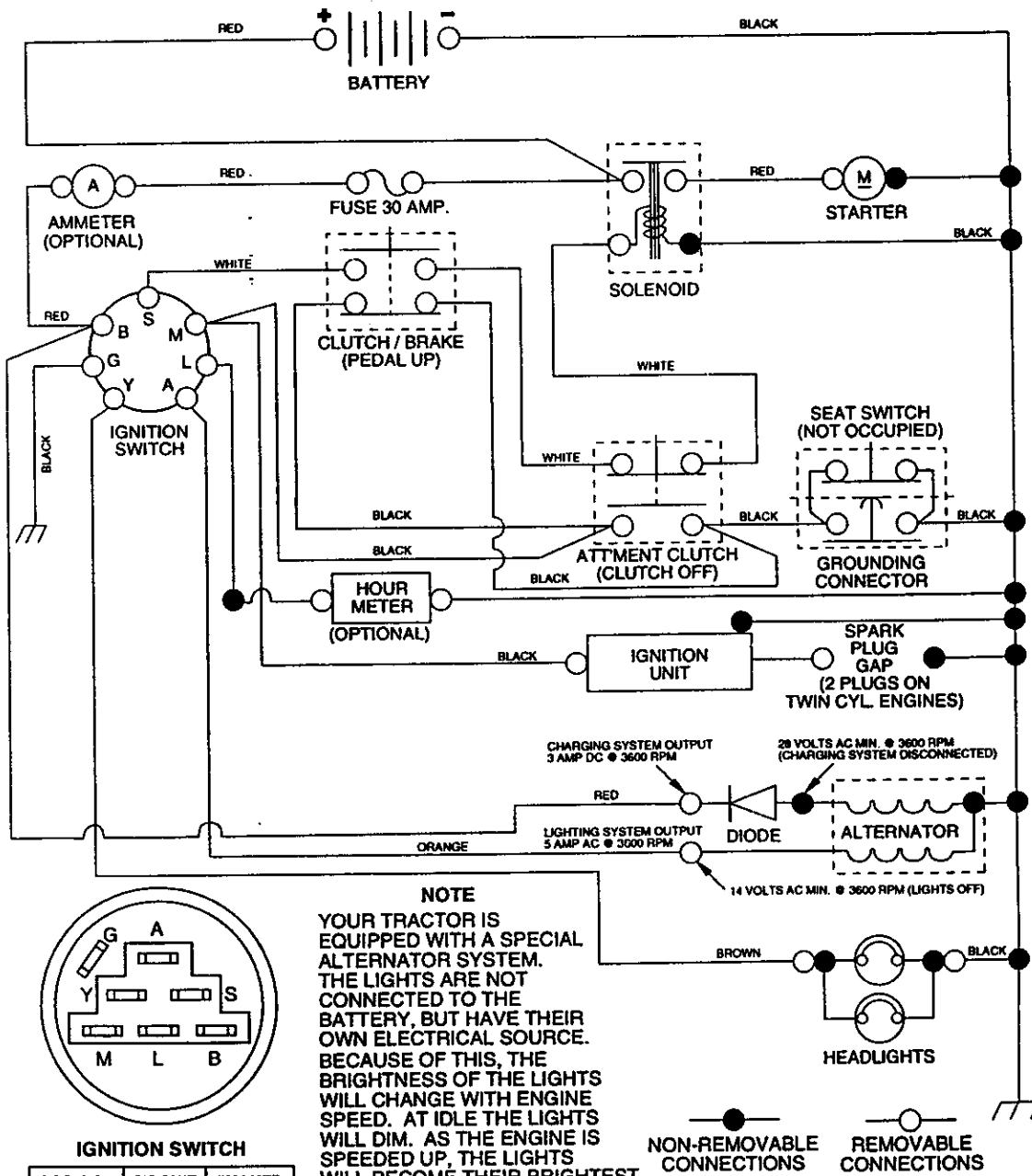

**IGNITION SWITCH**

POSITION	CIRCUIT	"MAKE"
OFF	G + M + L	NONE
RUN/LIGHT	B + L	A + Y
RUN	B + L	NONE
START	B + L + S	NONE

**NOTE**  
 YOUR TRACTOR IS EQUIPPED WITH A SPECIAL ALTERNATOR SYSTEM. THE LIGHTS ARE NOT CONNECTED TO THE BATTERY, BUT HAVE THEIR OWN ELECTRICAL SOURCE. BECAUSE OF THIS, THE BRIGHTNESS OF THE LIGHTS WILL CHANGE WITH ENGINE SPEED. AT IDLE THE LIGHTS WILL DIM. AS THE ENGINE IS SPEEDED UP, THE LIGHTS WILL BECOME THEIR BRIGHTEST.

**WIRING INSULATED CLIPS**  
**NOTE: IF WIRING INSULATED CLIPS WERE REMOVED FOR SERVICING OF UNIT, THEY SHOULD BE REPLACED TO PROPERLY SECURE YOUR WIRING.**



# SUGGESTED GUIDE FOR SIGHTING SLOPES FOR SAFE OPERATION

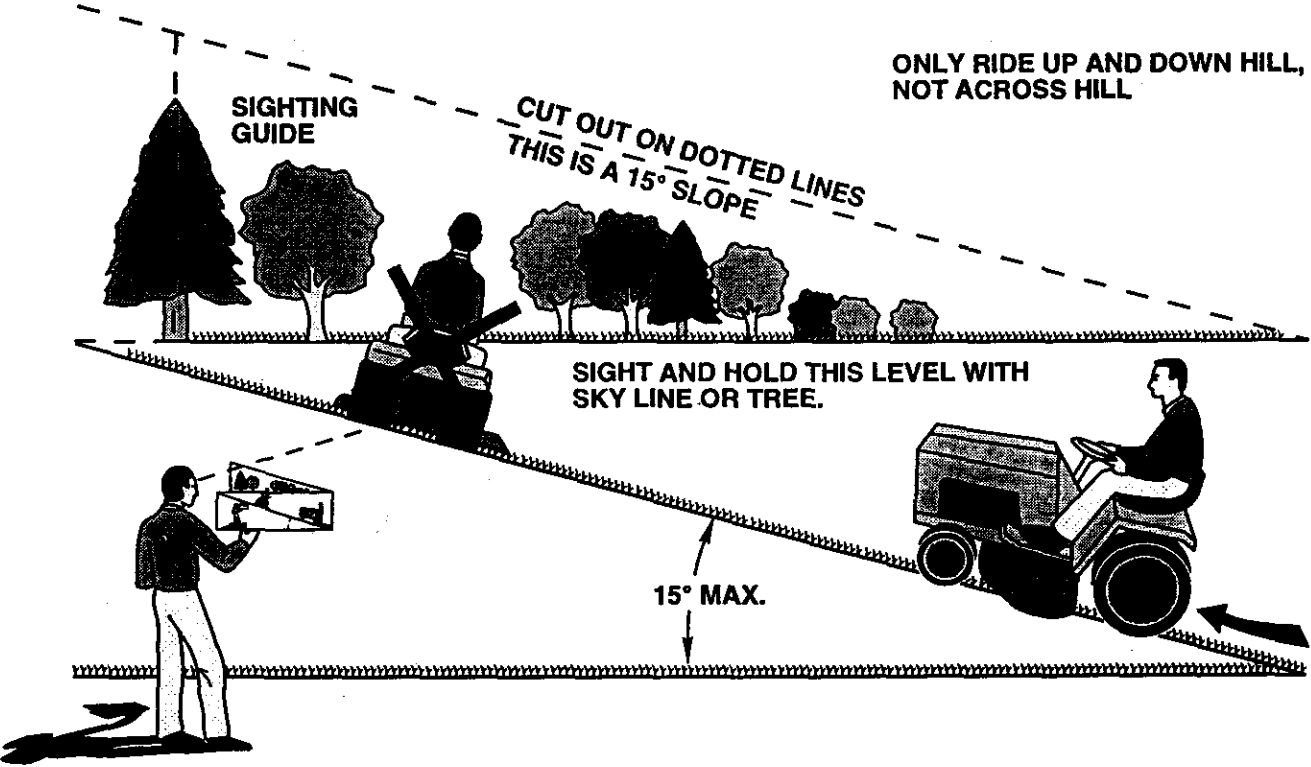

59

 Operate your Tractor up and down the face of slopes (not greater than 15°), never across the face. Make turns gradually to prevent tipping or loss of control. Exercise extreme caution when changing direction on slopes.

For the repair or replacement parts you need  
delivered directly to your home  
Call 7 am - 7 pm, 7 days a week  
**1-800-366-PART**  
(1-800-366-7278)  
Para ordenar piezas con entrega a  
domicilio - 1-800-659-7084

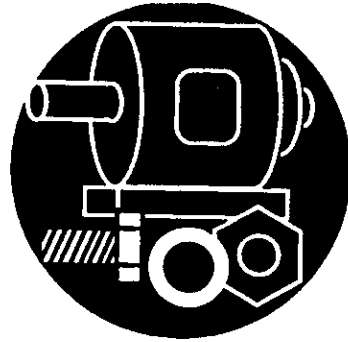

For in-house major brand repair service  
Call 24 hours a day, 7 days a week  
**1-800-4-REPAIR**  
(1-800-473-7274)  
Para pedir servicio de reparación a  
domicilio - 1-800-676-5811



For the location of a Sears Parts and  
Repair Center in your area  
Call 24 hours a day, 7 days a week  
**1-800-488-1222**



For information on purchasing a Sears  
Maintenance Agreement or to inquire  
about an existing Agreement  
Call 9 am - 5 pm, Monday-Saturday  
**1-800-827-6655**



When requesting service or ordering  
parts, always provide the following  
information:

- Product Type
- Part Number
- Model Number
- Part Description

**SEARS**  
**REPAIR SERVICES**  
*America's Repair Specialists*