

# Operator's Manual

# **CRAFTSMAN<sup>®</sup>**

## **8 HORSEPOWER REAR TINE TILLER**

**Model No: 987.293330**



### **CAUTION:**

**Before using this tiller, read this manual and follow all its Safety Rules and Operating Instructions.**

- **Safety Rules**
- **Assembly**
- **Operation**
- **Maintenance**
- **Parts**

**Sears, Roebuck and Co., Hoffman Estates, IL 60179 U.S.A.**

Visit the Craftsman web page: [www.sears.com/craftsman](http://www.sears.com/craftsman)

# SAFETY RULES



**CAUTION: ALWAYS DISCONNECT SPARK PLUG WIRE AND PLACE WIRE WHERE IT CANNOT CONTACT SPARK PLUG TO PREVENT ACCIDENTAL STARTING WHEN SETTING UP, TRANSPORTING, ADJUSTING OR MAKING REPAIRS.**



## TRAINING

1. Carefully read this Owner's Manual and any other literature you may receive before operating this equipment. Be thoroughly familiar with the controls and the proper use of the tiller and its engine. Know how to stop the unit and disengage the controls quickly.
2. Never allow children to operate the tiller. Never allow adults to operate the tiller without proper instruction.
3. Keep the area of operation clear of all persons, particularly children and pets. Keep bystanders at least 25 feet from area of operation.



4. Keep in mind that the operator or user is responsible for accidents or hazards occurring to other people, their property, and themselves.
5. Familiarize yourself with all of the safety and operating decals on this equipment and on any of its attachments or accessories.
6. Do not run engine in an enclosed area. Engine exhaust contains carbon monoxide gas, a deadly poison that is odorless, colorless, and tasteless. Do not operate this equipment near buildings, windows, or air conditioners.
7. Do not allow hands or any other part of the body or clothing near the rotating tines or near any other moving part. The tines begin to rotate backward once the engine starts, and either the Forward Clutch or the Reverse Clutch Lever is engaged (the Wheel Gear Lever must always be moved to ENGAGE before the engine is started).
8. Before inspecting or servicing any part of the equipment, shut off the

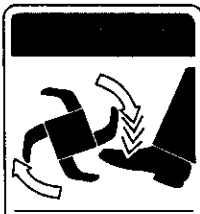

engine, wait for all moving parts to come to a complete stop, disconnect the spark plug wire from the spark plug, and move the wire away from the spark plug.

9. Do not operate this equipment if you are under the influence of alcohol, medication, or when tired or ill.

## PREPARATION

1. Thoroughly inspect the area where the tiller is to be used and remove all foreign objects.
2. Be sure all control levers are released and the Wheel Gear Lever is in ENGAGE before starting the engine.
3. Do not operate the tiller without wearing adequate outer garments. Avoid loose garments or jewelry that could get caught in moving parts of tiller or engine.
4. Do not operate the tiller when barefoot or wearing sandals, sneakers, or light footwear. Wear protective footwear that will improve footing on slippery surfaces.
5. Do not till near underground electric cables, telephone lines, pipes or hoses. If in doubt, contact your telephone or utility company.
6. **Warning:** Handle fuel with care; it is highly flammable and its vapors are explosive. Take the following precautions:
  - a. Store fuel in containers specifically designed for this purpose.
  - b. The gas cap shall never be removed or fuel added while the engine is running. Allow the engine to cool for several minutes before adding fuel.
  - c. Keep matches, cigarettes, cigars, pipes, open flames, and sparks away from the fuel tank and fuel container.
  - d. Fill fuel tank outdoors with extreme care. Never fill fuel tank indoors. Use a funnel or spout to prevent spillage.
  - e. Replace all fuel tank and container caps securely.
  - f. If fuel is spilled, do not attempt to start the engine, but move the

machine away from the area of spillage and avoid creating any source of ignition until fuel vapors have dissipated.

7. Never make adjustments when engine is running (unless recommended by manufacturer).

## OPERATION

1. Do not put hands or feet near or under rotating parts.
2. Exercise extreme caution when on or crossing gravel drives, walks, or roads. Stay alert for hidden hazards or traffic. Do not carry passengers.
3. After striking a foreign object, stop the engine, disconnect the spark plug wire and prevent it from touching the spark plug, carefully inspect the tiller for any damage, and repair the damage before restarting and operating the tiller.
4. Exercise caution to avoid slipping or falling.
5. If the unit should start to vibrate abnormally, stop the engine. Disconnect the spark plug wire and prevent it from touching the spark plug, and check immediately for the cause. Vibration is generally a warning of trouble.
6. Stop the engine, disconnect the spark plug wire and prevent it from touching the spark plug whenever you leave the operating position, before unclogging the tines, or when making any repairs, adjustments or inspections.
7. Take all possible precautions when leaving the machine unattended. Stop the engine. Disconnect spark plug wire and move it away from the spark plug. Move Wheel Gear Lever to ENGAGE.
8. Before cleaning, repairing, or inspecting, stop the engine, and make certain all moving parts have stopped. Disconnect the spark plug wire and prevent it from touching the spark plug to prevent accidental starting.
9. Always keep the tiller tine hood flap down.



**LOOK FOR THIS SYMBOL TO POINT OUT IMPORTANT SAFETY PRECAUTIONS. IT MEANS— ATTENTION!!! BECOME ALERT!!! YOUR SAFETY IS INVOLVED.**

# SAFETY RULES

10. Never use the tiller unless proper guards, plates, or other safety protective devices are in place.

11. Do not run engine in an enclosed area. Engine exhaust contains carbon monoxide gas, a deadly poison that is odorless, colorless, and tasteless.

12. Keep children and pets away.

13. Never operate the tiller under engine power if the Wheel Gear Lever is in DISENGAGE (FREEWHEEL). In this position, the wheels will not hold the tiller back and the revolving tines could propel the tiller rapidly backward, possibly causing loss of control. Always move the Wheel Gear Lever to ENGAGE before starting the engine or engaging the tines/wheels with the Forward Clutch or the Reverse Clutch.

14. Be aware that the tiller may unexpectedly bounce upward or jump backward if the tines should strike extremely hard packed soil, frozen ground, or buried obstacles like large stones, roots, or stumps. If in doubt about the tilling conditions, always use the following operating precautions to assist you in maintaining control of the tiller:

- a. Walk behind and to one side of the tiller, using one hand on the handlebars. Relax your arm, but use a secure hand grip.
- b. Use slower engine speeds.
- c. Clear the tilling area of all large stones, roots and other debris.
- d. Avoid using downward pressure on handlebars. If need be, use slight upward pressure to keep the tines from digging too deeply.
- e. **In an emergency, stop tines and wheels by releasing whichever Clutch Lever is engaged. Do not attempt to restrain the tiller.**

15. Do not overload the tiller's capacity by attempting to till too deeply at too fast a rate.

16. Never operate the tiller at high transport speeds on hard or slippery surfaces. Look behind and use care when backing up.

17. Do not operate the tiller on a slope that is too steep for safety. When on slopes, slow down and make sure you have good footing. Never permit the tiller to freewheel down slopes.

18. Never allow bystanders near the unit.

19. Only use attachments and accessories that are approved by the tiller manufacturer.

20. Use tiller attachments and accessories when recommended.

21. Never operate the tiller without good visibility or light.

22. Never operate the tiller if you are tired, or under the influence of alcohol, drugs or medication.

23. Operators shall not tamper with the engine-governor settings on the machine; the governor controls the maximum safe operating speed to protect the engine and all moving parts from damage caused by overspeed. Authorized service shall be sought if a problem exists.

24. Do not touch engine parts which may be hot from operation. Let parts cool down sufficiently.

25. Please remember: You can always stop the tines and wheels by releasing the Forward Clutch Lever or the Reverse Clutch Lever (whichever lever you have engaged) or by moving the Throttle Control Lever to STOP.

26. To load or unload the tiller, see the instructions in this Manual.

27. Use extreme caution when reversing or pulling the machine towards you.

28. Start the engine carefully according to instructions and with feet well away from the tines.

29. Never pick up or carry a machine while the engine is running.

## MAINTENANCE/STORAGE

1. Keep the tiller, attachments and accessories in safe working condition.

2. Check all nuts, bolts, and screws at frequent intervals for proper tightness to be sure the equipment is in safe working condition.

3. Never store the tiller with fuel in the fuel tank inside a building where ignition sources are present (such as hot water and space heaters, furnaces, clothes dryers, stoves, electric motors, etc.). Allow engine to cool before storing in any enclosure.

4. To reduce the chances of a fire hazard, keep the engine free of grass, leaves, or excessive grease.

5. Store gasoline in a cool, well-ventilated area, safely away from any spark- or flame-producing equipment. Store gasoline in an approved container, safely away from the reach of children.

6. Refer to the Service and Adjustments Section of this Manual if the tiller is to be stored for an extended period.

7. Never perform maintenance while the engine is running or the spark plug wire is connected, except when specifically instructed to do so.

8. If the fuel tank has to be drained, do this outdoors.

## WARNING

### TO AVOID INJURY:

- READ OWNER'S MANUAL.
- KNOW LOCATION AND FUNCTION OF ALL CONTROLS.
- KEEP ALL SAFETY DEVICES AND SHIELDS IN PLACE AND WORKING.
- NEVER ALLOW CHILDREN OR UNINSTRUCTED ADULTS TO OPERATE TILLER.
- SHUT OFF ENGINE AND DISCONNECT SPARK PLUG WIRE BEFORE UNCLOGGING TINES OR MAKING REPAIRS.
- KEEP BYSTANDERS AWAY FROM MACHINE.
- KEEP AWAY FROM ROTATING PARTS.
- USE EXTREME CAUTION WHEN REVERSING OR PULLING THE MACHINE TOWARDS YOU.

## WARNING:

The engine exhaust from this product contains chemicals known to the State of California to cause cancer, birth defects, or other reproductive harm.

CONGRATULATIONS on your purchase of a Sears Craftsman tiller. It has been designed, engineered and manufactured to give you the best possible dependability and performance.

Should you experience any problems you cannot easily remedy, please contact your nearest Sears Service Center/Department. We have competent, well-trained technicians and the proper tools to service or repair this machine.

Please read and retain this manual. The instructions will help you assemble and maintain your machine properly. Always observe the "SAFETY RULES."

## PRODUCT SPECIFICATIONS

HORSEPOWER:	8 HP
DISPLACEMENT:	19.43 CU. IN.
FUEL CAPACITY:	2 Quarts
SPARK PLUG (GAP 0.030-in.):	Champion RJ-17LM* or equivalent
IGNITION:	Electronic
NET ENGINE WEIGHT:	50 LBS.
NET TILLER WEIGHT:	204 LBS.

\* In Canada, replace spark plug with a resistor plug.

MODEL NUMBER: 987.293330

SERIAL  
NUMBER: \_\_\_\_\_

DATE OF  
PURCHASE: \_\_\_\_\_

THE MODEL AND SERIAL NUMBERS WILL BE FOUND ON A DECAL LOCATED ON THE TRANSMISSION OF YOUR MACHINE.

YOU SHOULD RECORD BOTH THE SERIAL NUMBER AND DATE OF PURCHASE AND KEEP IN A SAFE PLACE FOR FUTURE REFERENCE.

## MAINTENANCE AGREEMENT

A Sears maintenance agreement is available on this product. Contact your nearest Sears store for details.

## CUSTOMER RESPONSIBILITIES

- Read and observe the safety rules.
- Follow a regular schedule in maintaining, caring for and using this product.
- Follow the instructions under "CUSTOMER RESPONSIBILITIES" and "STORAGE" sections of this manual.

## ! WARNING

This machine is equipped with an internal combustion engine and should not be used on or near any unimproved forest-covered, brush-covered or grass-covered land unless the engine's exhaust system is equipped with a spark arrester meeting applicable local or state laws (if any). If a spark arrester is used, it should be maintained in effective working order by the operator.

In the state of California the above is required by law (Section 4442 of the California Public Resources Code). Other states may have similar laws. Federal laws apply on federal lands. This engine is not equipped with a spark arrester for the muffler. A spark arrester for the muffler is available through your nearest Sears authorized service center. See the REPAIR PARTS section of this manual.

## LIMITED TWO-YEAR WARRANTY ON CRAFTSMAN® TILLER

For two years from the date of purchase, when this Craftsman® Tiller is maintained, lubricated, and tuned up according to the operating maintenance instructions in the owner's manual, Sears will repair, free of charge, any defect in material or workmanship.

If this Craftsman® Tiller is used for commercial or rental purposes, this warranty applies for only 90 days from the date of purchase.

### THIS WARRANTY DOES NOT COVER:

- Expendable items which become worn during normal use, such as tine(s), belts, spark plug, and air cleaner.
- Repairs necessary because of operator abuse or negligence including bent crankshafts and the failure to maintain the equipment according to the instructions contained in the owner's manual.

**WARRANTY SERVICE IS AVAILABLE BY RETURNING THE CRAFTSMAN® TILLER TO THE NEAREST SEARS SERVICE CENTER IN THE UNITED STATES. THIS WARRANTY APPLIES ONLY WHILE THIS PRODUCT IS IN USE IN THE UNITED STATES.**

This warranty gives you specific legal rights, and you may also have other rights which vary from state to state.

Sears, Roebuck and Co., D/817WA, Hoffman Estates, IL 60179

# TABLE OF CONTENTS

<b>SAFETY RULES</b> .....2 <b>PRODUCT SPECIFICATIONS</b> .....4 <b>WARRANTY</b> .....4 <b>ACCESSORIES</b> .....6 <b>CONTENTS OF HARDWARE PACKAGE</b> .....7 <b>ASSEMBLY</b> .....8 <b>OPERATION</b> .....12 <b>CUSTOMER RESPONSIBILITIES</b> .....22	<b>SERVICE AND ADJUSTMENTS</b> .....26 <b>STORAGE</b> .....32 <b>TROUBLESHOOTING</b> .....33 <b>DECALS</b> .....34 <b>REPAIR PARTS - TILLER</b> .....35 <b>REPAIR PARTS - ENGINE</b> .....50 <b>PARTS ORDERING/SERVICE</b> .....Back Cover
---	--

## INDEX

<p style="text-align: center;"><b>A</b></p> Accessories .....6 Air Cleaner Maintenance .....25 Assembly .....8  <p style="text-align: center;"><b>B</b></p> Break-In Operation ..... 16 Belt Tension Adjustment ..... 28 Belt Removal and Replacement .30  <p style="text-align: center;"><b>C</b></p> Carburetor ..... 25 Changing Engine Oil ..... 24 Changing Transmission Oil . . . . 24 Checking/Adding Engine Oil . . . . 24 Checking/Adding Transmission Oil 24 Checking/Adjusting Belt Tension .28 Checking for Oil Leaks. . . . .23 Check List, Pre-Starting. . . . .15 Cleaning. . . . .25 Cooling System Maintenance . . .25 Controls . . . . .12  <p style="text-align: center;"><b>D</b></p> Decals .....34 Depth Regulator Lever .....14  <p style="text-align: center;"><b>E</b></p> Engine Air Filter ..... 25 Carburetor ..... 25 Choke Lever. . . . .15 Cooling System . . . . .25 Fuel Tank ..... 16 Oil, Checking/Adding . . . . .24 Operation . . . . .16 Parts . . . . .50 Recoil Start Rope . . . . .15 Spark Plug . . . . .25 Speed. . . . .15 Starting Engine. . . . .16 Stopping Engine. . . . .16 Storage. . . . .32 Throttle Lever . . . . .10,15	<p style="text-align: center;"><b>F</b></p> Features/Controls .....12 Forward Clutch .....9,13 Forward Travel .....17 Fuel Tank .....16  <p style="text-align: center;"><b>G</b></p> Guiding the Tiller .....17  <p style="text-align: center;"><b>H</b></p> Handlebar Height Adjustment . .8,14 Hardware .....7  <p style="text-align: center;"><b>L</b></p> Leaks, Oil .....23 Loading and Unloading Tiller . . .21 Location of Controls .....12 Lubrication .....23  <p style="text-align: center;"><b>M</b></p> Maintenance Schedule .....22 Maintenance Agreement .....4 Model/Serial Number .....4 Motor Oil, Adding .....15, 24 Motor Oil, Changing .....24  <p style="text-align: center;"><b>O</b></p> Oil .....15 Off-Season Storage .....32 Operation .....17  <p style="text-align: center;"><b>P</b></p> Parts List .....35 Pre-Start Checklist .....15 Product Specifications .....4  <p style="text-align: center;"><b>R</b></p> Reverse Clutch .....13 Reverse Travel .....18 Recoil Starter Rope .....15 Repair Parts .....35	<p style="text-align: center;"><b>S</b></p> Safety Rules .....2 Safety Decals .....34 Seedbed Preparation .....19 Service Recommendation Checklist .....22 Slopes .....20 Spark Plug .....25 Starter Rope .....15 Storage .....32  <p style="text-align: center;"><b>T</b></p> Tiller Parts .....35 Tilling .....17 Tilling Depths .....19 Tine Cleaning .....20 Tine Removal .....26 Transmission Gear Oil .....24 Troubleshooting .....33 Turning Around .....18  <p style="text-align: center;"><b>U</b></p> Unpacking .....8 Untangling Tines .....20  <p style="text-align: center;"><b>W</b></p> Warranty .....4 Wheel Gear Lever .....12 Wheel Gear Cable Adjustment . .26
---	--	---

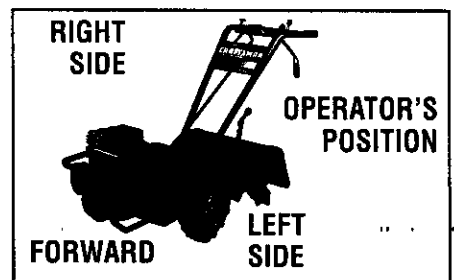

**OPERATOR'S POSITION**  
 All references to LEFT and RIGHT sides of the tiller are given from the operator's position behind the handlebars (unless specified otherwise).

# ACCESSORIES

These accessories were available when the tiller was purchased. They are available at most Sears retail outlets, catalog and service centers. Most Sears stores can order repair parts for you when you provide the model number of your tiller.

## ACCESSORIES

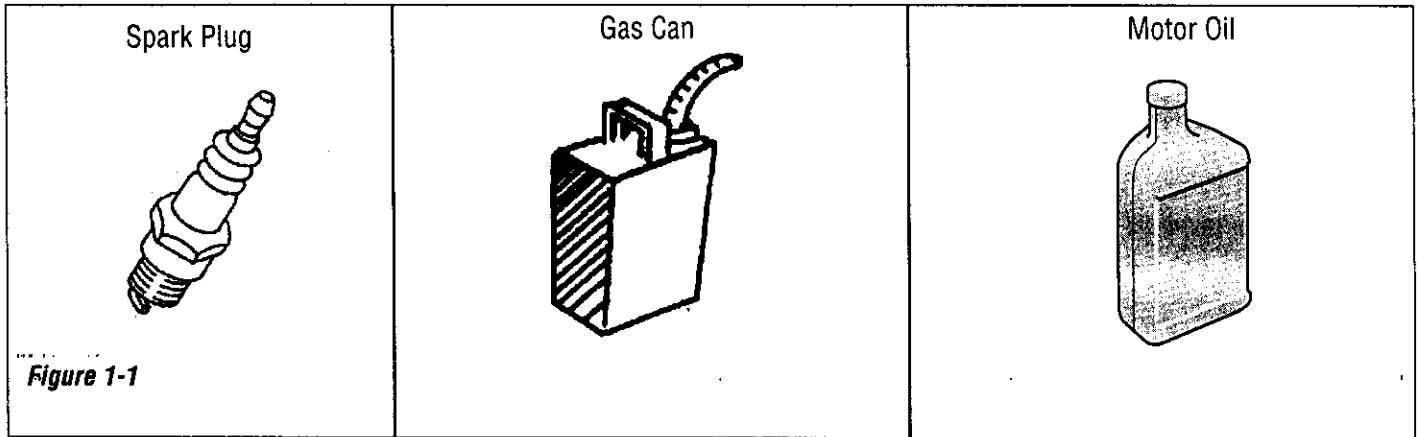

# COMPONENTS REQUIRING ASSEMBLY

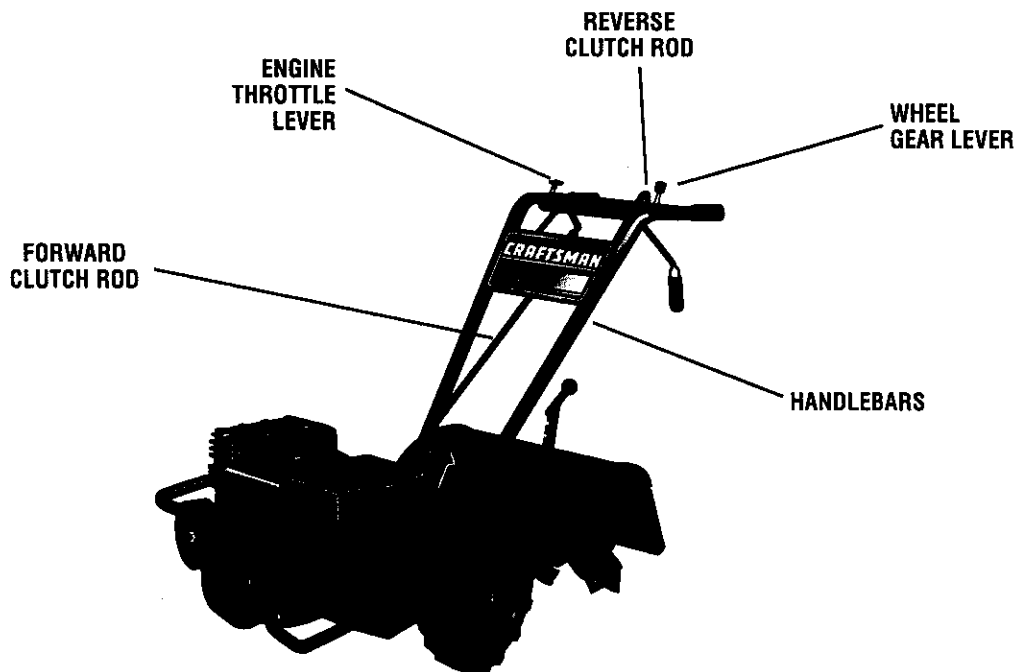

*Figure 1-2*

# CONTENTS OF HARDWARE PACK

## Hardware packed in carton

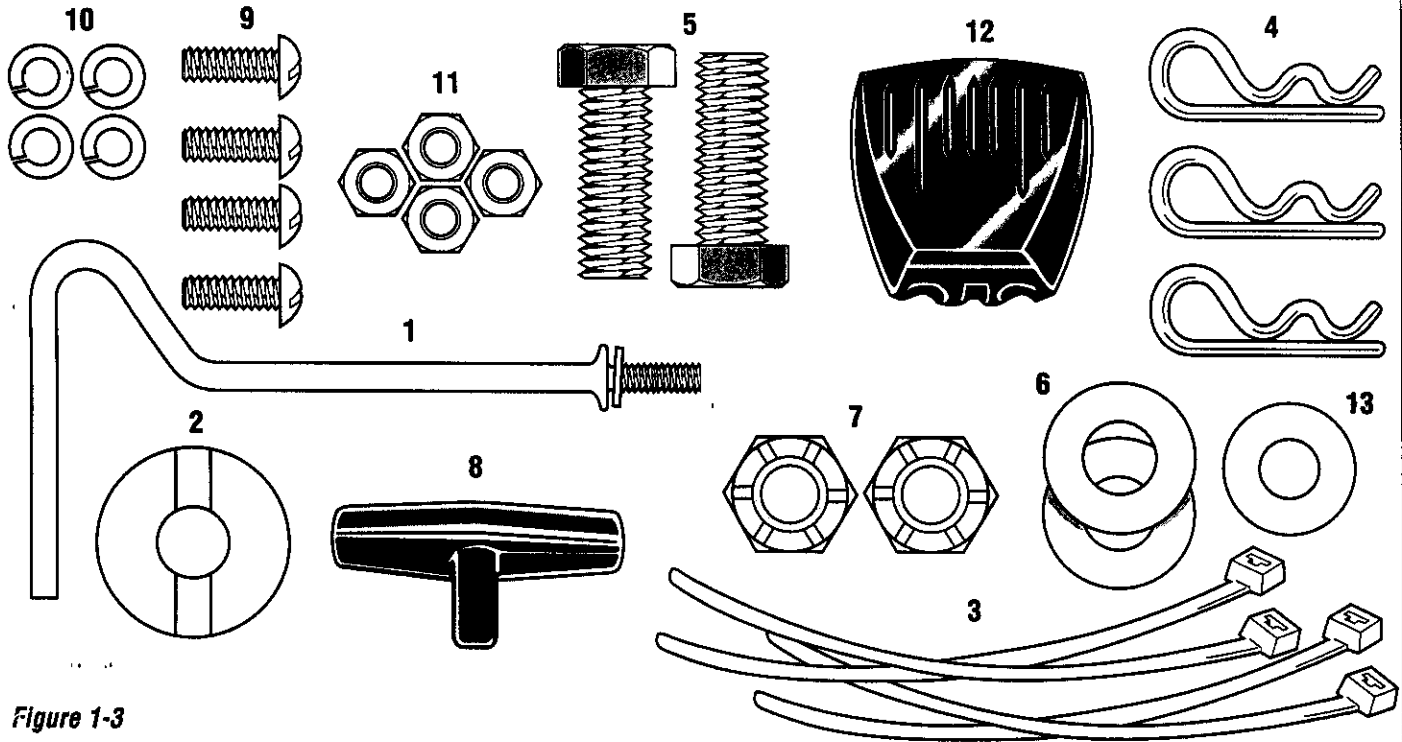

Figure 1-3

Ref. No.	Hardware Description	Qty.
1	Height Adjustment Handle (for handlebar) .....	1
2	Keyed Washer (for height adjustment handle) .....	1
3	Plastic Tie Strap .....	4
4	Hairpin Cotter .....	3
5	3/8"-16 1" Hex Hd. Screw .....	2
6	3/8" Flat Washer .....	2
7	3/8"-16 Nylok Lock Nuts .....	2
8	Throttle Lever Knob .....	1
9	#10-32 x 1/2" Round Hd. Screw .....	4
10	#10 Lockwasher .....	4
11	#10-32 Nut .....	4
12	Wheel Gear Lever Knob .....	1
13	5/16" Flat Washer .....	1

### TOOLS/MATERIALS NEEDED FOR ASSEMBLY

- (1) \* 3/8" open end wrench
- (2) \* 9/16" open end wrenches
- (1) Scissors (to trim plastic ties)
- (1) Ruler
- (1) Small Board (to tap plastic knobs on control levers)
- (1) Automotive-type air pressure gauge
- (1) Clean Oil Funnel
- (1) Clean high-quality engine oil. Refer to the assembly instructions in this manual for engine oil specifications and quantity required. Do not overfill.

\* Adjustable wrenches may be used.

**IMPORTANT:** Motor oil must be added to the engine crankcase before the engine is started. Follow the instructions in the "Operation" section.

# ASSEMBLY

Read these instructions completely before you attempt to assemble or operate your new equipment. Your tiller has been assembled at the factory with the exception of those parts left unassembled for shipping purposes. Steps in this section show you how to assemble them. To ensure safe and proper operation of your machine, all parts and hardware you install or adjust must be tightened securely. Use the correct tools as necessary to ensure proper tightness.

## UNPACKING INSTRUCTIONS

- Inspect your machine immediately. Be sure neither the carton nor contents have been damaged. If you find or have reason to suspect damage, contact the nearest Sears Service Center for assistance.
- Once the cardboard shipping carton is open, remove any packing material from around the machine. Remove any staples securing bottom of carton to wood pallet. Lift off carton. Before disposing of the carton or any of the packing materials, be sure to check them thoroughly for any small parts.
- Leave unit on base of pallet during assembly steps (to safely remove unit from pallet, wait until you have installed the handlebar assembly and the Wheel Gear Lever is placed in DISENGAGE).
- The procedure for removing the tiller is explained in Step 1, item 6 of these assembly steps.
- Also remove any packaging around the handlebar.
- Perform the assembly on a clean, level surface. If you need to move the machine, be careful not to severely bend any of the control cables on the equipment.
- Remove the handlebar assembly from the carton. Do not remove the two control levers from the handlebars.
- A plastic bag inside the literature envelope contains loose hardware. Open the bag and check the contents against the hardware list on Page 7 and the hardware shown in Figure 1-3.

## ASSEMBLY STEPS

### STEP 1: Attach the Handlebars

1. Remove the Reverse Clutch Lever (B, Figure 2-1) from the handlebars (A). Remove any rubber bands from the handlebars.
2. Position the handlebar cross-brace (C, Figure 2-2) in front of the curved height adjustment bracket (D) and place the handlebar ends to the outside of the two mounting tabs on top of the transmission.
3. Attach the handlebars to the mounting tabs with two 3/8-16 x 1" screws (heads of screws go to inside of tabs), 3/8" flat washers and 3/8"-16 Nylok lock nuts (see Figure 2-2). Do not fully tighten the screws at this time.
4. Move the handlebar to align the hole in the cross-brace with one of the four slots in the curved height adjustment bracket. Place the keyed washer (E, Figure 2-3) on the height adjustment handle (F) with the raised keys (edges) on the keyed washer facing down.
5. Screw the height adjustment handle (F) into the threaded hole in the handlebar cross-brace, making sure that the raised keys on the washer fit into the selected slot on the curved bracket. Tighten the height adjustment handle securely. Next, securely tighten the two screws that attach the handlebar ends to the mounting tabs (Figure 2-2).
6. To remove the tiller from its shipping platform, free the wheels by moving the Wheel Gear Lever (G, Figure 2-4) to the DISENGAGE position (this allows the wheels to rotate). Carefully unwrap the wheel gear cable from around the unit before moving the lever. Use this DISENGAGE mode only when the engine is not running. Before starting the engine, the Wheel Gear Lever must be placed in the ENGAGE position (see the "Operation" section for details).

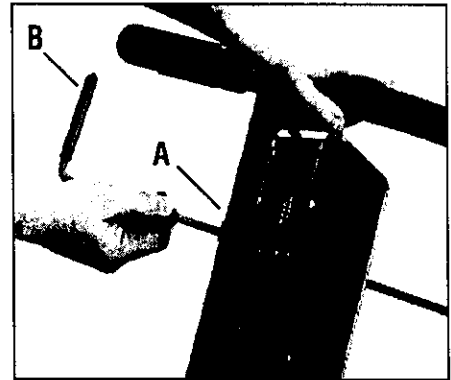

Figure 2-1: Remove Reverse Clutch Lever.

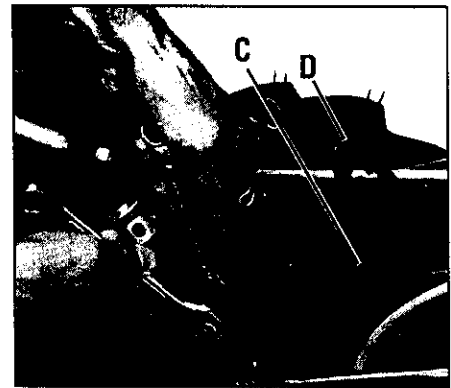

Figure 2-2: Attach handlebars.

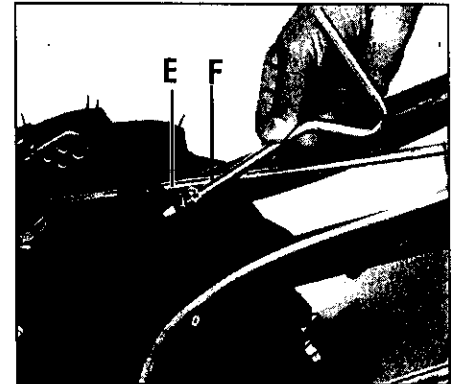

Figure 2-3: Install height adjustment handle.

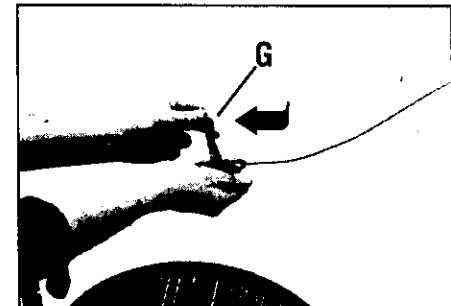

Figure 2-4: Put Wheel Gear Lever in DISENGAGE position.



# ASSEMBLY

## STEP 2: Attach Reverse Clutch Lever

1. Slide the Reverse Clutch Lever (removed in Step 1) down through the hole in the left side of the handlebar control panel and pass it above the cross-brace at the lower end of the handlebar.
2. Insert the end of the lever (I, Figure 2-5) through the hole in the pivot (J). Note that there are two small holes in the lower end of the lever.
3. Install a 5/16" flat washer (K) and secure it with a hairpin cotter (L) through the *bottom* hole in the lever.

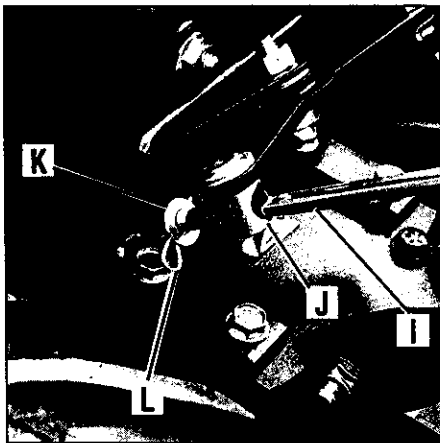

Figure 2-5: Install Reverse Clutch Lever.

**IMPORTANT:** If the handlebar is adjusted to the *highest* position, then the bottom of the Reverse Clutch Lever must be secured with the hairpin cotter (L) through the *top* hole in the lever. Simply remove the hairpin cotter, slide the washer (K) up the lever, and replace the hairpin cotter.

## STEP 3: Attach Forward Clutch Rod

1. The upper end of the Forward Clutch rod is attached to the bottom of the handlebar control panel. Turn the rod (M, Figure 2-6) so the small bend at its lower end points inward.
2. Insert a hairpin cotter down through the hole located closest to the bend (see Figure 2-6).
3. There are four numbered holes in the clutch swivel plate (see Figure 2-7) and four numbered slots in the curved height adjustment bracket. For correct operation of the Forward Clutch rod, the numbered hole used for the Forward Clutch rod must

match with the numbered slot in the height adjustment bracket. For example, if the handlebar is set in slot #1, then the Forward Clutch rod must be installed in hole #1 of the clutch swivel plate.

**IMPORTANT:** Whenever the handlebar height is changed, the hole position of the Forward Clutch rod must be changed accordingly. Changing the handlebar height changes the tension on the Forward Clutch rod – this tension must be adjusted by relocating the rod in the appropriate hole in the clutch swivel plate.

4. Select the proper hole in the clutch swivel plate and insert the Forward Clutch rod so that the tip faces inward (see Figure 2-7). *Secure the rod by inserting a second hairpin cotter through the hole near the tip of the rod.*

5. Check for correct tension on the Forward Clutch rod as follows:

- (a) There are two interconnected Forward Clutch paddles that hang beneath the control panel. Lift and hold the right-side paddle against the handlebar grip.
- (b) While squeezing the paddle, measure the gap between the E-ring and the lower end of the clutch rod bracket (see Figure 2-8). The gap should be 3/16"-to-5/16". **NOTE:** A stack of 5 pennies is approximately 5/16" thick.
- (c) If the gap is incorrect:
  - (1) First check that the Forward Clutch rod is in the correct hole in the clutch swivel plate. If not, reposition the rod and repeat Step 5b.

- (2) If the Forward Clutch rod is in the correct hole and the gap is incorrect, you will need to adjust the length of the Forward Clutch rod. To do this, first release the Forward Clutch paddle and then disconnect the rod from the clutch swivel plate (remove hairpin cotter at end of rod and pull rod out of hole in clutch swivel plate).

*If the gap is more than 5/16", rotate the rod counterclockwise (as viewed from the front of tiller) to decrease the gap. Reinstall the rod in the correct clutch swivel plate hole, se-*

*cure it with the hairpin cotter, and repeat Steps 5a and 5b.*

*If the gap is less than 3/16", rotate the rod clockwise (as viewed from the front of tiller) to increase the gap. Reinstall the rod in the correct clutch swivel plate hole, secure it with the hairpin cotter, and repeat Steps 5a and 5b.*

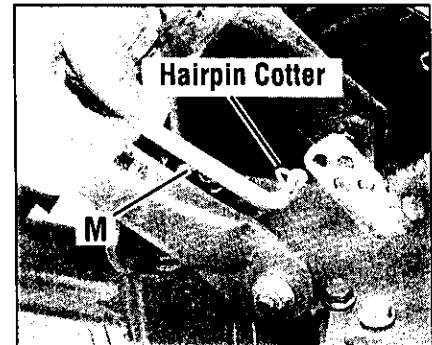

Figure 2-6: Install Forward Clutch rod.

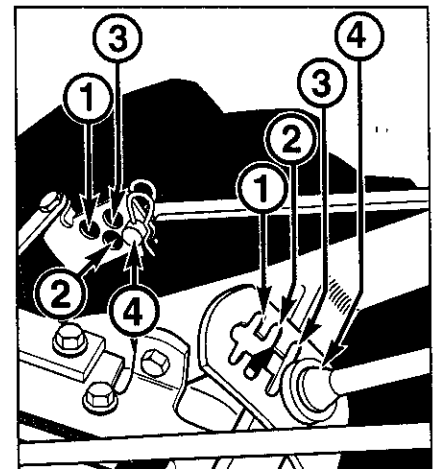

Figure 2-7: Numbered settings for handlebar height slots and clutch swivel plate holes.

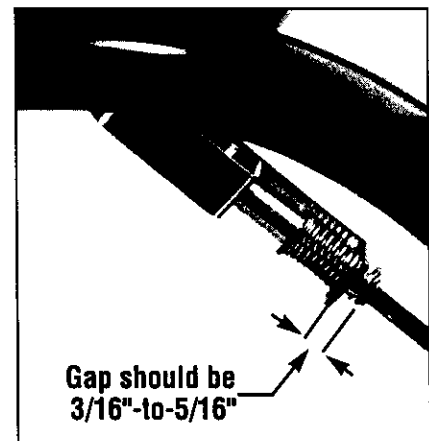

Figure 2-8: While squeezing Forward Clutch paddle, measure gap between end of bracket and E-ring.

# ASSEMBLY

## STEP 4: Check Gear Oil Level in Transmission

The transmission was filled with gear oil at the factory. However, be sure to check the oil level at this time.

1. Move the tiller to a level area.
2. Pull the Depth Regulator Lever (N, Figure 2-9) straight back and then slide it to the second notch from the top. If the lever does not move freely, lift the tine hood flap and look for a plastic tie securing the lever in place. Cut and remove the tie.
3. Remove the oil level check plug (O, Figure 2-10) on the left-side of the transmission. (Due to dried paint on the plug threads, it may require some force to remove the plug the first time.) The gear oil level is correct if oil starts to flow out of the hole as the plug is removed. If so, securely reinstall the plug.
4. If oil does not flow from the check hole, add SAE 140, SAE 85W-140 or SAE 80W-90 weight gear oil (preferably use API rated GL-4 gear oil, however GL-5 can be used for small top-offs) as follows:

**NOTE:** Do not use automatic transmission fluid or engine oil in the transmission.

- (a) Clean area around oil fill hole (P, Figure 2-11) and unscrew oil fill plug.
- (b) Using a clean funnel, slowly add gear oil until it flows from the oil level check hole (O, Figure 2-10). Securely reinstall the oil level check plug (O).
- (c) Reinstall and tighten the oil fill plug.

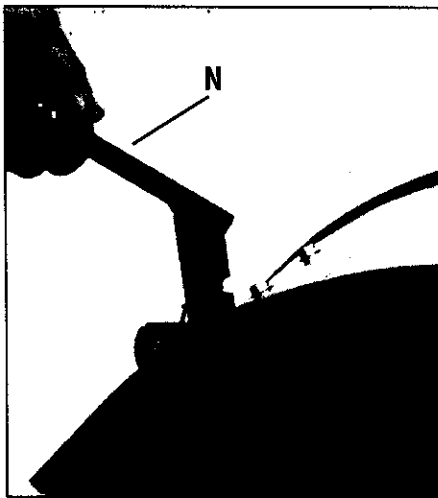

Figure 2-9: Put lever in second notch.

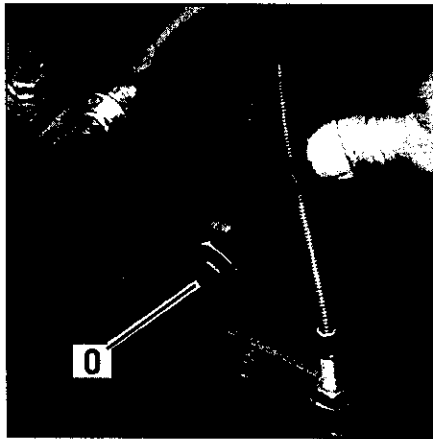

Figure 2-10: Gear oil level check plug.

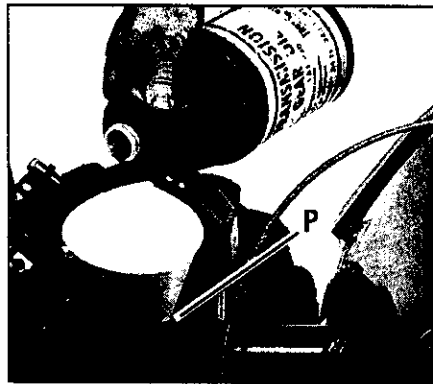

Figure 2-11: Adding gear oil in oil fill hole.

## STEP 5: Attach Throttle Lever

For shipping purposes, the engine throttle cable assembly is wrapped around the engine. Carefully unwrap the cable and attach it as follows:

1. Route the throttle cable up the right-side handlebar. Insert its lever (R, Figure 2-12) up through the slot in the control panel labeled "ENGINE THROTTLE."
2. Insert two #10-32 x 1/2" round head screws down through the "+" marks on the control panel decal and through the holes in the base of the engine throttle lever.
3. Hold the engine throttle lever base against the bottom of the control panel and secure it with two #10 lockwashers and #10-32 nuts.
4. Place the "T" shaped engine throttle lever knob on the end of the lever. Use a board to tap knob until it seats firmly on lever (Figure 2-12).
5. Move the lever forward and backward – it should move freely through the full range of travel. (Note that there is a detent at the SLOW setting

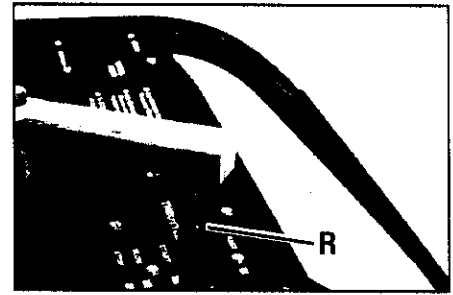

Figure 2-12: Attach engine throttle lever.

which catches the lever. This detent prevents the lever from unintentionally moving to the STOP setting when you are just trying to slow the engine down.) If the lever is difficult to move away from the STOP setting, loosen both screws and move the lever assembly slightly to the left. Retighten screws and recheck movement. Adjust the lever as needed.

6. Secure the throttle cable to the right-side handlebar with two plastic ties (S, Figure 2-13) located about two feet apart. The serrated side of the tie must be on the inside of the loop. Trim tie length with scissors.

## STEP 6: Attach Wheel Gear Lever

For shipping purposes, the wheel gear cable is wrapped around the transmission. Carefully unwrap the cable and attach it as follows:

1. Route the wheel gear cable up the left-side handlebar and insert the lever (T, Figure 2-14) up through the slot in the control panel that is labeled "WHEEL GEAR."
2. Insert two #10-32 x 1/2" round head screws down through the "+" marks on the control panel decal and through the holes in the base of the wheel gear lever.
3. Hold the wheel gear lever base against the bottom of the control panel and secure it with two #10 lockwashers and #10-32 nuts.
4. Place the wheel gear lever knob on the end of the lever and use a board to tap the knob down until it seats firmly on the lever (see Figure 2-14).
5. Secure the cable to the left-side handlebar with two plastic ties (U, Figure 2-13) located about two feet apart. Snip off any excess tie length with scissors.

# ASSEMBLY

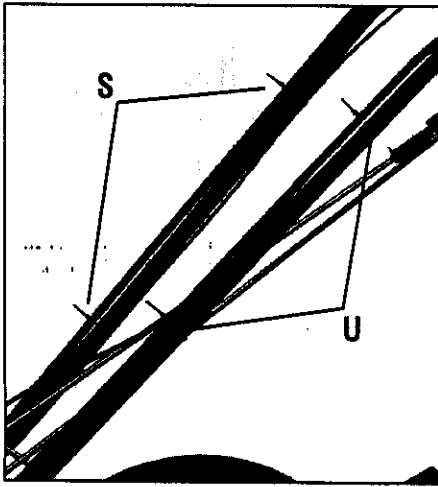

*Figure 2-13: Attach throttle cable with plastic ties (S). Attach wheel gear cable with plastic ties (U).*

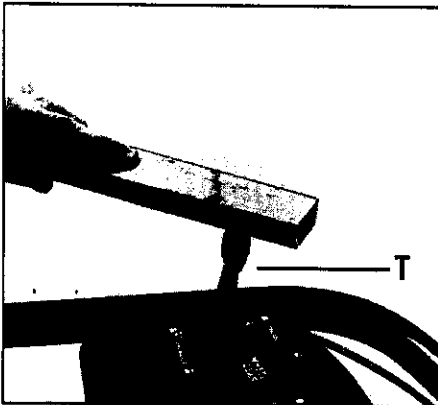

*Figure 2-14: Attach wheel gear lever.*

## STEP 7: Check Air Pressure in Tires

Use an automotive-type tire pressure gauge to check the air pressure in both tires. Deflate or inflate both tires evenly from 15-to-20 PSI (pounds per square inch). Be sure that both tires have the same air pressure or the unit will pull to one side.

## STEP 8 : Check Hardware for Tightness

Inspect the hardware on the unit and tighten any loose screws, bolts and nuts.

**IMPORTANT:** Motor oil must be added to the engine crankcase before the engine is started. Follow the instructions in the "Operation" section.



## CAUTION

Unit is shipped without oil in engine crankcase. **DO NOT** start engine until oil has been added. Severe engine damage will result if this instruction is not followed. See "Operation" Section in this manual for oil filling procedure.

# OPERATION

## KNOW YOUR TILLER

READ THIS OWNER'S MANUAL AND ALL SAFETY RULES BEFORE OPERATING THIS EQUIPMENT. Know the location and function of all features and controls on the equipment. Save this manual for future reference.

### MEETS ANSI B71.8 – 1996 SAFETY STANDARD

This machine meets voluntary safety standard B71.8 – 1996, which is sponsored by the Outdoor Power Equipment Institute, Inc., and is published by the American National Standards Institute, Inc.

### Operating Symbols

Various symbols are used on the tiller to indicate control settings (your model may not have all of the symbols). These symbols are shown below with a description of their meaning.



FAST



SLOW



CHOKE



ENGINE STOP



ENGINE START



ENGINE RUN



ENGAGE



DISENGAGE



ROTATING TINES



TILLER DIRECTION



STOP



LEVER DIRECTION

N

NEUTRAL

R

REVERSE

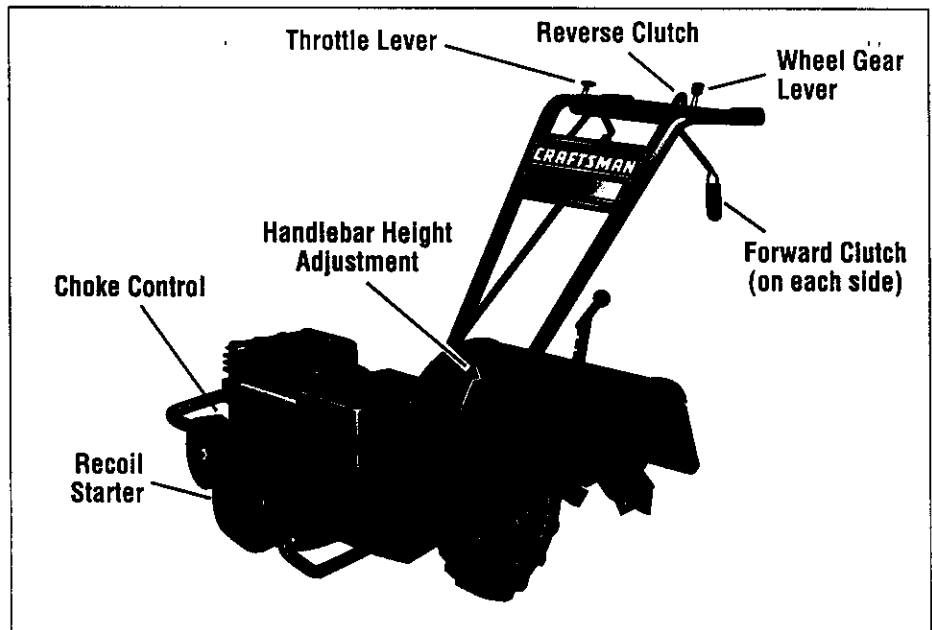

### LOCATION AND USE OF TILLER CONTROLS

#### Wheel Gear Lever

This lever (A, Figure 3-1) has two operating positions: ENGAGE and DISENGAGE.

In the ENGAGE position, the wheels will start turning when either the Forward Clutch or the Reverse Clutch is engaged (the tines will also start turning when either clutch is engaged).

The DISENGAGE position places the wheels in the freewheeling mode to allow the unit to be moved without the engine running. Use the DISENGAGE position only when the engine is not running. See "DANGER" statement that follows.

To shift to ENGAGE, gently (do not force) move the lever forward while also rolling the tiller a few inches forward or backward. (Moving the tiller helps to align the shift mechanism with the transmission wheel drive gears.) The wheels will not free-wheel when the lever is properly set in the ENGAGE position.

To shift to DISENGAGE (freewheel) simply move the lever rearward, without rolling the tiller. The wheels will roll freely when the lever is properly set in the DISENGAGE position.

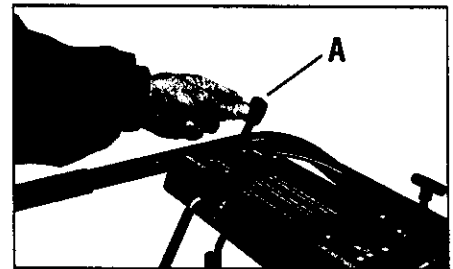

Figure 3-1: Wheel Gear Lever.



### DANGER

Never place the Wheel Gear Lever in DISENGAGE (Free-wheel) when the engine is running.

Having the Wheel Gear Lever in DISENGAGE and then engaging the tines/wheels with either the Forward Clutch or the Reverse Clutch could allow the tines to propel the tiller rapidly backward.

Failure to follow this instruction could result in personal injury or property damage.

# OPERATION

## Forward Clutch

The two interconnected levers (B, Figure 3-2) control the engagement of forward drive to the wheels and power to the tines.

### To Operate the Forward Clutch:

1. Before engaging the Forward Clutch, put the Wheel Gear Lever in the ENGAGE position (see "WARNING" below).
2. Lift and hold one or both of the levers against the handlebar grips to engage the wheels and tines.
3. Release BOTH levers to disengage the wheels and tines. All forward motion will stop (the engine will continue to run).

## ! WARNING

**Never engage the wheels and tines with the Forward Clutch or the Reverse Clutch unless the Wheel Gear Lever is in ENGAGE.**

**Engaging the Forward Clutch or the Reverse Clutch when the wheels are not engaged could allow the tines to rapidly propel the tiller forward or backward.**

**Failure to follow this warning could result in personal injury or property damage.**

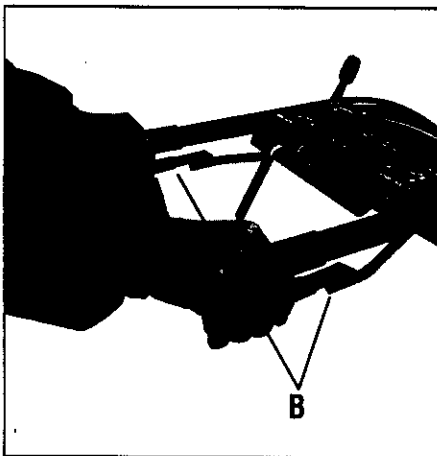

Figure 3-2: Forward Clutch levers.

**IMPORTANT:** The Forward Clutch Levers are connected to a mechanical interlock feature that automatically shifts the separate Wheel Gear Lever (A, Figure 3-1) into ENGAGE position when either of the Forward Clutch Levers is lifted up against the handlebars to engage power to the wheels and tines. This is a safety feature designed to prevent the wheels from being in DISENGAGE (freewheel) position when the tines are rotating.

Before starting the engine, test the function of the mechanical interlock as follows:

1. Put the Wheel Gear Lever in the DISENGAGE position and roll the tiller back and forth a few inches. The wheels should roll freely.
2. At rest, squeeze either of the Forward Clutch Levers ("paddles") against the handlebar grips. As the "paddles" move upward, the mechanical interlock will automatically move the Wheel Gear Lever forward into the ENGAGE position. (Roll the tiller back and forth a few inches.) If it does, the tiller wheels will not roll freely when you push and pull on the handlebars.
3. The mechanical interlock is working properly if it performed as described in step 2. If the mechanical interlock did not perform correctly, do not operate the tiller until it has been inspected and corrected by your Sears Service Center.

## Reverse Clutch

This lever (C, Figure 3-3) controls the engagement of reverse drive to the wheels and tines. It is the only control that provides reverse direction of the wheels and tines.

### To Operate the Reverse Clutch:

1. Before engaging the Reverse Clutch, put the Wheel Gear Lever in ENGAGE (see "WARNING" statement on this page).
2. Release the Forward Clutch levers.
3. To move the tiller in reverse, first stop all forward motion. Then lift up the handlebars until the tines clear the ground and pull the Reverse Clutch lever out. The tines and wheels will rotate in a reverse direction as long as the lever is held in REVERSE. To stop the wheels and tines, release the lever and it will return to NEUTRAL. Never attempt to till while going in the reverse direction.

## ! WARNING

- Use extreme caution when reversing or pulling the machine toward you. Look behind to avoid obstacles.
- Never attempt to till in reverse.

**Failure to follow this warning could result in personal injury or property damage.**

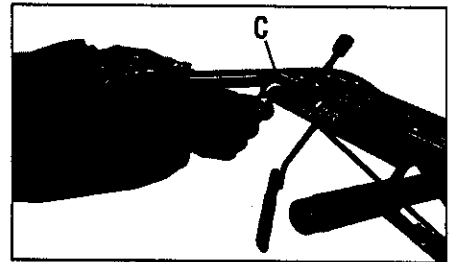

Figure 3-3: Reverse Clutch lever.

# OPERATION

## Depth Regulator

This lever (D, Figure 3-4) controls the tilling depth of the tines. Pull the lever straight back and slide it up or down to engage the notched height settings.

The highest notch (lever all the way down) raises the tines approximately 1-1/2 inches off the ground. This "travel" position allows the tiller to be moved without the tines digging into the ground.

Moving the lever up increases the tilling depth. The lowest notch allows a tilling depth of approximately six to eight inches, depending on soil conditions.

For best results, always begin tilling at a shallow depth setting, then increase the tilling depth. Further information on using the Depth Regu-

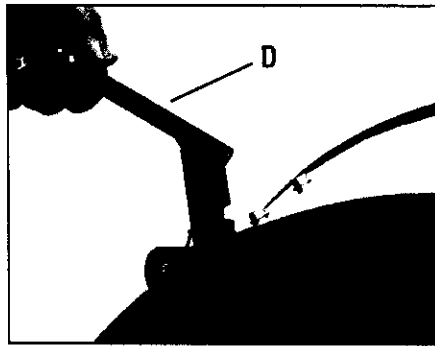

Figure 3-4: Depth Regulator Lever.

lator is found in the "Operation" Section of this manual.



## WARNING

Always place the Depth Regulator Lever in the "travel" position before starting the engine. This position prevents the tines from touching the ground until you are ready to begin tilling.

Failure to follow this warning could result in personal injury or property damage.

## Handlebar Height Adjustment

The handlebar height is adjustable to four different settings. Set the handlebar height to a comfortable setting, but keep in mind that the handlebar will be lower when the tines are engaged in the soil.



## WARNING

Whenever the handlebar height is changed, the Forward Clutch shift mechanism must be readjusted.

When adjusting or checking the Forward Clutch mechanism, shut engine off, disconnect spark plug wire and prevent it from touching the spark plug.

Failure to follow this warning could allow the Forward Clutch mechanism to operate improperly which could result in personal injury or property damage.

## To Adjust the Handlebar Height:

1. Stop the engine, wait for all parts to stop moving and then disconnect the spark plug wire.
2. Loosen the two screws at the lower ends of the handlebar.
3. Loosen the height adjustment handle (E, Figure 3-5) and pull the keyed washer (F) free of the slots in the curved height adjustment bracket.
4. Move the handlebars to the new slot setting and insert the raised keys on the keyed washer into the slot. Tighten the height adjustment handle securely.
5. Retighten the two screws at the ends of the handlebar.
6. Adjust the tension on the Forward Clutch rod shift mechanism, as follows:
  - (a) Remove the inner hair pin cotter from the end of the Forward Clutch rod.
  - (b) There are four numbered holes in the clutch swivel plate (see Figure 3-6) and four numbered slots in the curved height adjustment bracket. For correct operation of the Forward Clutch mechanism, the numbered hole used for the Forward Clutch rod must match the numbered slot in the height adjustment bracket. Example: If handlebar is in slot #4, put Forward Clutch rod in hole #4 of clutch swivel plate.
  - (c) Select the correct hole in the clutch swivel plate and insert the Forward Clutch rod (tip faces inward). Secure the rod with the hairpin cotter.
  - (d) Check for correct tension on the Forward Clutch rod as described in Step 5 of "Step 3: Attach Forward Clutch Rod" on page 9.

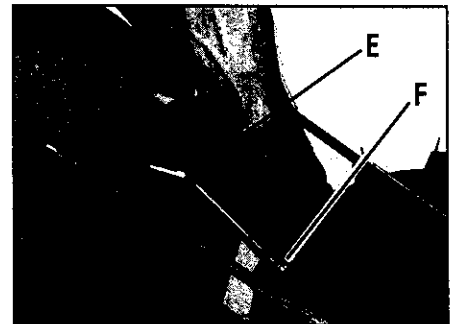

Figure 3-5: Height Adjusting handle (E).

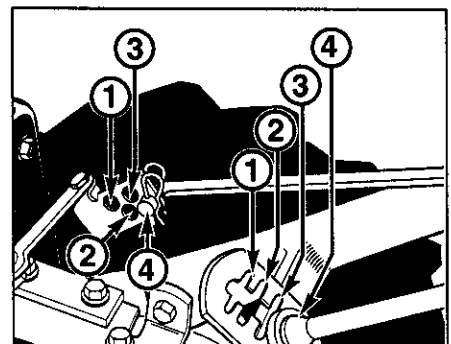

Figure 3-6: Handlebar height slots and clutch swivel plate holes.

**IMPORTANT:** If the handlebar is adjusted to the *highest* position, then the bottom of the Reverse Clutch Lever must be secured with the hairpin cotter (and washer) through the top hole in the lever (see K and L) in Figure 2-5, Page 9.

# OPERATION

## ENGINE CONTROLS

**IMPORTANT:** The engine is equipped with a recoil starter, a handlebar-mounted engine throttle lever, and a choke control. The locations and functions of each of these controls are described below.

### Recoil Starter

The recoil starter (G, Figure 3-7) is used to "pull-start" the engine.

Before pulling the recoil starter handle, make sure there are no obstacles behind you. See "Engine Starting and Stopping" in this section for detailed engine starting instructions.

### Engine Choke Lever

The choke lever (H, Figure 3-7) allows a richer air/gas mixture to make starting a cold engine easier. There

are three settings: FULL CHOKE, PARTIAL CHOKE and NO CHOKE. Detailed instructions for using the choke lever are provided later in this section.

### Engine Throttle Lever

The throttle lever (I, Inset to Figure 3-7) is used to adjust engine speed as well as stop the engine.

Use the START position when starting the engine. Use the SLOW position when idling the engine. Pull the lever all the way back to the STOP position to turn the engine off.

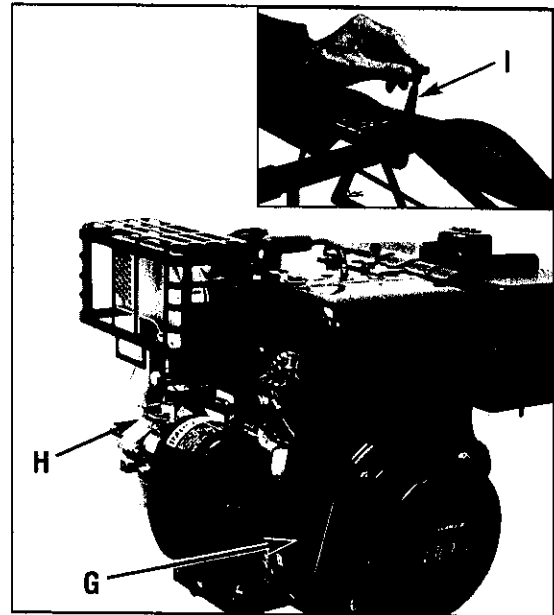

Figure 3-7: Engine controls— Recoil Starter (G); Throttle Lever (H); Choke Lever (I).

## BEFORE STARTING ENGINE

### Add Motor Oil to Engine

The tiller is shipped without oil in the engine. Permanent engine damage will result if the engine is run without oil.

1. Only use high quality detergent oil with API service classification SF, SG, SH, or SH/CD. Above 32°F, use SAE 30; below 32°F, use 5W30. Do not use SAE 10W40 oil.

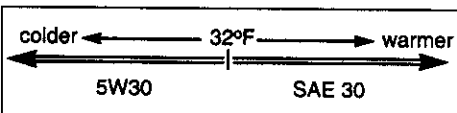

**NOTE:** Although multi-viscosity oils (5W30, 10W30, etc.) improve starting in cold weather, these oils will result in increased oil consumption when used above 32°F. Check engine oil more frequently to avoid possible engine damage from running low on oil.

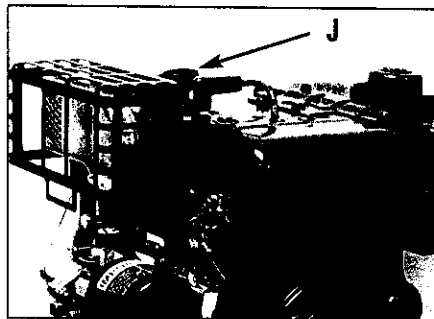

Figure 3-8: Add motor oil to the engine using the oil fill tube (J).

2. With the tiller on level ground, pull the Depth Regulator Lever (Figure 3-4) back and then all the way up until the lowest notch in the lever is engaged.

3. Unscrew the engine oil dipstick (J, Figure 3-8) from the oil fill tube. Using a clean funnel, slowly add oil into the oil fill tube until the oil level reaches the FULL mark reading on the oil dipstick. While adding oil, check the level several times with

the dipstick so as to avoid overfilling the engine with oil. ALWAYS MAINTAIN THE OIL LEVEL AT THE FULL MARK.

4. Securely replace the oil dipstick.

**IMPORTANT:** Experience indicates that alcohol-blended fuels (gasohol or using ethanol or methanol) can attract moisture which leads to separation and formation of acids during storage. Acidic gas can damage the fuel system of an engine while in storage. To avoid problems, the fuel system should be emptied before storage for 30 days or longer. Drain the gas tank, start the engine and let it run until the fuel lines and carburetor are empty. Use fresh fuel next season. See STORAGE instructions for additional information. Never use engine or carburetor cleaner products in the fuel tank or permanent damage may occur.

## Pre-Start Checklist

Move the tiller to a level area, then make the following checks and perform the following services before starting the engine.

1. Disconnect Spark Plug Wire.

2. Add motor oil to engine. (Refer to instructions on this page.)

3. Check the Air Cleaner. It must be securely assembled and clean.

4. Check Safety Guards. All guards and covers must be fastened securely.

5. Check Engine Cooling System. The cooling fins and air intake screen must be clear of debris.

6. Adjust Handlebar Height.

7. Put Gasoline in the Fuel Tank. (Refer to instructions on next page.) Use fresh, clean, unleaded regular fuel. Fuel goes stale if stored for more than six months. Do Not Mix Oil With Gasoline!

8. Put Depth Regulator Lever in the "travel" position.

9. Reconnect Spark Plug Wire.

# OPERATION

## Fill Fuel Tank

The engine must be off and cool before removing fuel fill cap (Figure 3-9).

Clean area around fuel fill cap and then remove fill cap. Be sure to use clean, fresh unleaded regular gasoline. Do not mix oil with gasoline.

**NOTE:** Do not use gasoline containing methanol (wood alcohol). Never use stale gasoline left over from last season or unused for long periods.

Using a funnel or spout, fill tank to within 1/2" below the bottom of the fuel tank filler neck to prevent spills and to allow for fuel expansion. Install the fill cap securely and wipe up any spilled gasoline.



Figure 3-9: Fill the fuel tank (K).

## DANGER

Gasoline is highly flammable and its vapors explosive. Follow these safety practices to prevent injury from fire or explosion:

- Never fill tank if engine is running or hot from use. Let engine and muffler cool down before refueling.
- Do not permit open flames, sparks, matches or smoking in fueling area.
- Fill fuel tank outdoors in a well-ventilated area. Wipe up any fuel spills and move tiller away from fumes before starting the engine.
- Use only an approved fuel container and lock it safely away from children.
- Store fuel and the tiller in a well-ventilated area. Do not store fuel or tiller where fuel vapors may reach an open flame or spark, or an ignition source (a hot water heater, furnace, clothes dryer, electric motor, or the like).
- Let engine cool before storing.

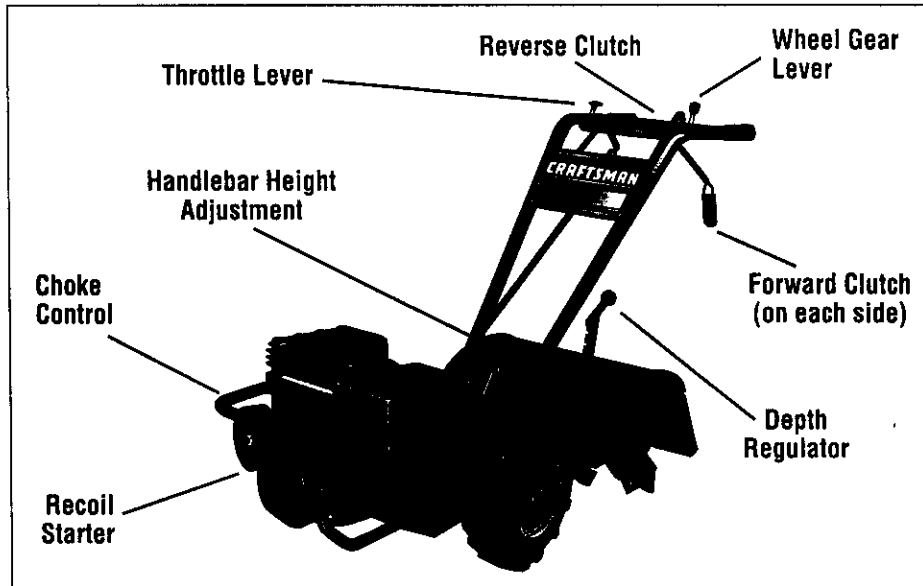

Figure 3-10



## WARNING

Before operating your machine, carefully read and understand all Safety and Operation instructions in this Manual and on the decals on the machine.

Failure to follow these instructions can result in serious personal injury.

## STOPPING AND STARTING THE ENGINE

### Break-in Operation

Perform the following maintenance during the first hours of new operation (see "Customer Responsibilities" section of this manual).

1. Change engine oil after first 2 hours of new engine operation.
2. Check for loose or missing hardware on unit. Tighten or replace as needed.

### Stopping the Engine

The following steps describe how to stop the engine.

1. To stop the wheels and tines, release the Forward Clutch levers or the Reverse Clutch lever (whichever control is in use).

2. To stop the engine, move the Engine Throttle Lever to the STOP position.

## Starting the Engine

The following steps describe how to start the engine. Do not attempt to engage the tines or wheels until you have read all of the operating instructions in this Section. Also review the safety rules in the Safety Section.

1. Complete the "Pre-Start Checklist".
2. Put the Wheel Gear Lever (Figure 3-10) in the ENGAGE position.
3. Put the Depth Regulator Lever (see Figure 3-10) in the "travel" position (lever all the way down) so that the tines are clear of the ground.
4. Release all controls on the tiller.
5. If engine is equipped with a fuel shutoff valve, turn valve to the open position.
6. Put the Engine Throttle Lever (Figure 3-10) in the START setting.
7. Choke the engine (see Figure 3-10) as follows: Move choke lever to FULL CHOKE position (move in direction of arrowhead located on lever).

**NOTE:** If restarting a warm engine after a short shutdown, move choke lever to NO CHOKE position instead.



# OPERATION

## ! CAUTION

To help prevent serious personal injury or damage to equipment:

- Before starting engine, put Wheel Gear Lever in ENGAGE position.
- Before starting engine, put Forward Clutch Levers and Reverse Clutch Lever in neutral (disengaged) positions by releasing levers.
- Never run engine indoors or in enclosed, poorly ventilated areas. Engine exhaust contains carbon monoxide, an odorless, colorless and deadly gas.
- Avoid engine muffler and nearby areas. Temperatures in these areas may exceed 150°F.

## ! DANGER

**GASOLINE IS HIGHLY FLAMMABLE AND ITS VAPORS ARE EXPLOSIVE.**

Follow gasoline safety rules in this manual (see Safety Section).

Failure to follow gasoline safety instructions can result in serious personal injury and property damage.

then to NO CHOKE position. If engine falters, move choke lever to 1/2 CHOKE until engine runs smoothly and then to NO CHOKE position.

**NOTE:** If engine fails to start after 3 pulls, move choke lever to NO CHOKE position and pull starter rope again.

**NOTE:** If engine fires, but does not continue to run, move choke lever to FULL CHOKE and repeat instructions "a", "b", and "c" until engine starts.

## OPERATING THE TILLER

The following pages provide guidelines to using your tiller effectively and safely in various gardening applications. Be sure to read "Tilling Tips & Techniques" in this Section before you actually put the tines into the soil.

## ! WARNING



Keep away from rotating tines. Rotating tines will cause serious personal injury.

3. Start the engine and allow it to warm up. When warm, put throttle control in fast speed setting.

4. For forward motion of the wheels and tines:

- (a) Pull the Forward Clutch lever "paddles" up and hold them against the handlebars. To stop forward motion of the wheels and tines, release the "paddles."
- (b) As the tiller moves forward, relax and let the wheels pull the unit along while the tines dig. Walk behind and a little to one side of the tiller. Use a light but secure grip with one hand on the handlebars, but keep your arm loose. See Figure 3-11. Let the tiller move ahead at its own pace and do not push down on the handlebars to try and force the tiller to dig deeper – this takes weight off the wheels, reduces traction, and causes the tines to try and propel the tiller.

8. Pull recoil starter rope, as follows:

- (a) Check behind you before pulling the recoil starter handle. Avoid contacting any obstacles when pulling the handle. Place one hand on the fuel tank to stabilize the unit when you pull the starter handle.
- (b) Pull recoil handle until you feel resistance. Let rope rewind fully. Then pull rope out rapidly. Maintain control of rope so it slowly returns into starter mechanism. This action may need to be repeated several times until the engine starts.
- (c) When engine starts, gradually move choke lever (on engines so equipped) to 1/2 CHOKE until engine runs smoothly and

1. Follow the "Pre-Start Checklist" on Page 15. Be sure the Wheel Gear Lever is in the ENGAGE position.

2. Put the Depth Regulator Lever in the "travel" position (lever all the way down) so that the tines are clear of the ground. Use this position when practicing with your tiller or when moving to or from the garden. When you are ready to begin tilling, you must move the Depth Regulator Lever to the desired depth setting (see "Tilling Tips & Techniques").

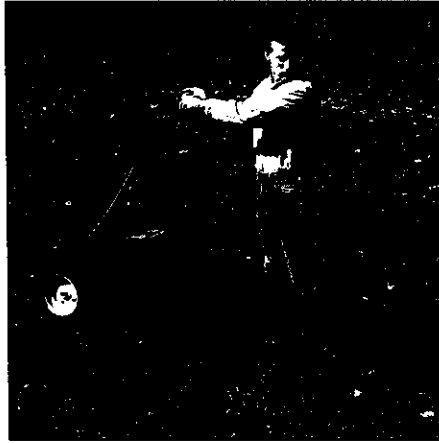

Figure 3-11: Use one hand to guide tiller when moving

# OPERATION

5. For reverse motion of the tiller (tines and wheels):

- (a) Look behind and exercise caution when operating in reverse. Do not till while in reverse.
- (b) Stop all forward motion before reversing. Lift the handlebars with one hand until the tines are off the ground and then pull the Reverse Clutch lever out to engage reverse motion (see Figure 3-12). To stop reverse motion, let go of the Reverse Clutch lever.



*Figure 3-12: Raise tines off ground and look behind when moving in reverse.*

6. To Turn the Tiller Around:

- (a) Practice turning the tiller in a level, open area. Be very careful to keep your feet and legs away from the tines.
- (b) To make a turn, reduce the engine speed and then lift the handlebars until the engine and tines are balanced over the wheels (Figure 3-13).
- (c) With the tiller balanced, push sideways on the handlebar to move the tiller in the direction of the turn (Figure 3-14). After completing the turn, slowly lower the tines into the soil and increase the engine speed.

## Stopping the Tiller and Engine

1. To stop the wheels and tines, release the Forward Clutch "paddles" or the Reverse Clutch Lever (whichever is engaged).
2. To stop the engine, move the Engine Throttle Lever to STOP.

## Turning the Tiller Around



*Figure 3-13: To begin turn, reduce engine speed and lift handlebars until engine and tines are balanced over wheels.*



*Figure 3-14: With tiller balanced over wheels (and tines out of the ground), push handlebars sideways to turn tiller.*

## Tilling Tips & Techniques

### Let the tiller do the work

- While tilling, relax and let the wheels pull the tiller along while the tines do the digging. Walk on the side that is not yet finished (to avoid making footprints in the freshly tilled soil) and lightly, but securely grip the handlebar with just one hand. See Figure 3-11.
- Avoid the temptation to push down on the handlebars in an attempt to force the tiller to dig deeper. Pushing down on the handlebars takes the weight off the powered wheels, causing them to lose traction. Without the wheels helping to hold the tiller back, the tines will attempt to propel the tiller – causing the tiller to move rapidly back toward you. (Sometimes, slight downward pressure on the handlebars will help get through a particularly tough section of sod or unbroken ground, but in most cases this won't be necessary at all.)

### Tilling depths

- This is a CRT (counter-rotating tine) tiller. As the wheels pull forward, the tines rotate backward. This creates an “uppercut” tine action which digs deeply, uprooting soil and weeds. Don't overload the engine, but dig as deeply as possible on each pass. On later passes, the wheels may tend to spin in the soft dirt. Help them along by lifting slightly on the handlebar (using just one hand, palm upward, works most easily).
- Watering the garden area a few days prior to tilling will make tilling easier, as will letting the newly worked soil rest for a day or two before making a final, deep tilling pass.
- When cultivating (breaking up the surface soil around plants to help destroy weeds), adjust the tines to dig only 1-1/2" to 2" deep. Using shallow tilling depths helps prevent injury to plants whose roots often grow close to the surface. If needed, lift up on the handlebars slightly to prevent the tines from digging too deeply. Cultivating on a regular basis not only eliminates weeds, it also loosens and aerates the soil for better moisture absorption and faster plant growth.)

### Avoid tilling soggy, wet soil

- Tilling wet soil often results in large, hard clumps of soil that can interfere with planting. If time permits, wait a day or two after heavy rains to allow the soil to dry before tilling. Test soil by squeezing it into a ball. If it compresses too easily, it is too wet to till.

### Avoid making footprints

- Whenever possible, walk on the untilled side of the unit to avoid making footprints in your freshly tilled or cultivated soil. Footprints cause soil compaction that can hamper root penetration and contribute to soil erosion. They can also “plant” unwanted weed seeds back into the freshly tilled ground.

### Choosing correct wheel and tine speed

With experience, you will find the “just right” tilling depth and tilling speed combination that is best for your garden.

Set the engine throttle lever at a speed to give the engine adequate power and yet allow it to operate at the slowest possible speed...at least until you have achieved the maximum tilling depth you desire. Faster engine speeds may be desirable when making final passes through the seedbed or when cultivating. Selection of the correct engine speed, in relation to the tilling depth, will ensure a sufficient power level to do the job without causing the engine to labor.

### Suggested tilling patterns

- When preparing a seedbed, go over the same path twice in the first row, then overlap one-half the tiller width on the rest of the passes (see Figure 3-15). When finished in one direction, make a second pass at a right angle as shown in Figure 3-16. Overlap each pass for best results (in very hard ground it may take three or four passes to thoroughly pulverize the soil).
- If the garden size will not permit lengthwise and then crosswise tilling, then overlap the first passes by one-half a tiller width, followed by successive passes at one-quarter width (see Figure 3-17).

- With planning, you can allow enough room between rows to cultivate (see Figure 3-18). Leave room for the hood width, plus enough extra room for future plant growth.

### Clearing the tines

The tines have a self-clearing action which eliminates most tangling of debris in the tines. However, occasionally dry grass, stringy stalks or tough vines may become tangled. Follow these procedures to help avoid tangling and to clean the tines, if necessary.

- To reduce tangling, set the depth regulator deep enough to get maximum “chopping” action as the tines chop the material against the ground. Also, try to till under crop residues or cover crops while they are green, moist and tender.
- While power composting, try swaying the handlebars from side to side (about 6" to 12"). This “fishtailing” action often clears the tines of debris.
- If the procedures above don't clear the debris, it may be necessary to remove the debris by hand (a pocket knife will help you cut away the material).



### WARNING

**Before clearing the tines by hand, stop the engine, allow all moving parts to stop and disconnect the spark plug wire.**

**Failure to follow this warning could result in personal injury.**

## Tilling Tips & Techniques

### Tilling on slopes

If you must garden on a moderate slope, please follow two very important guidelines:

1. Till only on moderate slopes, never on steep ground where footing is difficult (review safety rules in the "Safety" section of this manual).
2. We recommend tilling up and down rather than across slopes or using terraces cut into a slope. Tilling vertically on a slope allows maximum planting area and also leaves room for cultivating.

**IMPORTANT:** When tilling on slopes, be sure the correct oil level is maintained in the engine (check every one-half hour of operation). The incline of the slope will cause the oil to slant away from its normal level and this can starve engine parts of required lubrication. Keep the engine oil level at the full point at all times!

### Tilling up and down slopes

- To keep soil erosion to a minimum, be sure to add enough organic matter to the soil so that it has good moisture-holding texture and try to avoid leaving footprints or wheel marks.
- When tilling vertically, try to make the first pass uphill since the tiller digs more deeply going uphill than it does downhill. In soft soil or weeds, you may have to lift handlebars slightly while going uphill. When going downhill, overlap the first pass by about one-half the width of the tiller.



### WARNING

Do not operate the tiller on a slope too steep for safe operation. Till slowly and be sure that you have good footing.

Failure to follow this warning could result in personal injury.

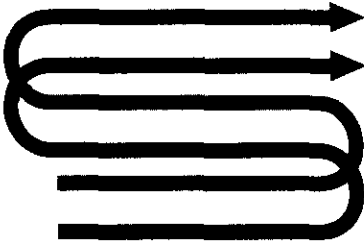

Figure 3-15

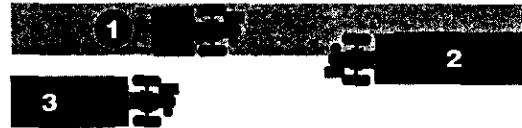

Figure 3-17

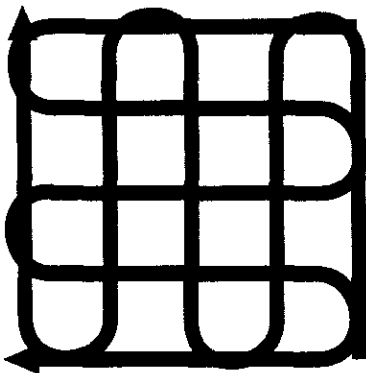

Figure 3-16

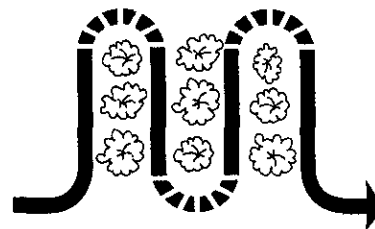

Figure 3-18

---

# OPERATION

---

## LOADING AND UNLOADING THE TILLER

### **!** WARNING

Loading and unloading the tiller into a vehicle is potentially hazardous and we don't recommend doing so unless absolutely necessary, as this could result in personal injury or property damage.

However, if you must load or unload the tiller, follow the guidelines given next.

- Before loading or unloading, stop the engine, wait for all parts to stop moving, disconnect the spark plug wire and let the engine and muffler cool. Move the spark plug wire away from the spark plug.
- The tiller is too heavy (165 to 240 lbs., depending on model) and bulky to lift safely by one person. Two or more people should share the load.

- Use sturdy ramps and manually (with engine shut off) roll the tiller into and out of the vehicle. Two or more people are needed to do this.
- Ramps must be strong enough to support the combined weight of the tiller and any handlers. The ramps should provide good traction to prevent slipping; they should have side rails to guide the tiller along the ramps; and they should have a locking device to secure them to the vehicle.
- The handlers should wear sturdy footwear that will help to prevent slipping.
- Position the loading vehicle so that the ramp angle is as flat as possible (the less inclined the ramp, the better). Turn the vehicle's engine off and apply its parking brake.
- When going up ramps, stand in the normal operating position and push the tiller ahead of you. Have a person at each side to turn the wheels.
- When going down ramps, walk backward with the tiller following you. Keep alert for any obstacles behind you. Position a person at each wheel to control the speed of the tiller. Never go down ramps tiller-first, as the tiller could tip forward.
- Use wooden blocks to place on the downhill side of the wheels if you need to stop the tiller from rolling down the ramp. Also, use the blocks to temporarily keep the tiller in place on the ramps (if necessary), and to chock the wheels in place after the tiller is in the vehicle.
- When the tiller is in the vehicle, prevent it from rolling by engaging the wheels in the wheel drive position (move Wheel Gear Lever to ENGAGE). Chock the wheels with blocks and securely tie down the tiller.

# CUSTOMER RESPONSIBILITIES

## ! WARNING

Before inspecting, cleaning or servicing the machine, shut off engine, wait for all moving parts to come to a complete stop, disconnect spark plug wire and move wire away from spark plug.

Failure to follow these instructions can result in serious personal injury or property damage.

## GENERAL RECOMMENDATIONS

The warranty on this machine does not cover items that have been subjected to operator abuse or negligence. To receive full value from the warranty, the operator must maintain the machine as instructed in this manual.

Some adjustments will need to be made periodically to properly maintain your machine.

Keep the air filters clean and change the spark plug annually. A clean air filter system and a new spark plug will help your engine run better and last longer.

## REQUIRED MAINTENANCE SCHEDULE

PROCEDURE	Before Each Use	Every 10 Hours	Every 30 Hours	Every 50 Hours	As Noted
Lubricate Tiller		•			
Check for Oil Leaks	•				
Check Hardware		•			†
Check gear oil level (see "Transmission Gear Oil Service")			•		†
Check engine oil level (see "Engine Oil Service")	•				And every five operating hours
Change engine oil (see "Engine Oil Service")		•			*
Service foam pre-cleaner air filter, if so equipped (see "Air Cleaner Service")					Every 25 hours*
Service paper air filter (see "Air Cleaner Service")					Every 30 hours*
Service Spark Plug				•	
Clean Engine	•				
Check tines for wear (see "Tines")		•			
Check/Adjust Tension on Drive Belts		•			†
<p>* Change more frequently in dusty or dirty conditions. Change after first 2 hours of break-in operation.</p> <p>† Check after first 2 hours of break-in operation.</p>					

# CUSTOMER RESPONSIBILITIES



**WARNING** Before inspecting, cleaning or servicing the unit, shut off engine, wait for all parts to come to a complete stop, disconnect spark plug wire and move wire away from spark plug. Failure to follow these instructions can result in serious personal injury or property damage.



## Regular Maintenance

Because the tiller is operated in the garden, frequently under hot and dirty conditions, regular maintenance is very important to ensure that you are getting proper performance from your tiller. There are several maintenance procedures that will help keep your tiller in good operating condition.

- Change engine oil regularly.
- Lubricate the controls regularly.
- Keep the correct tension on the forward drive belt.
- Replace the engine air cleaner element when dirty.
- Keep engine cooling fins clean.

## Tiller Lubrication

After every 10 operating hours, oil or grease the lubrication points shown in Figures 4-1 and 4-2 and described below.

Use a good quality lubricating oil (#30 weight engine oil is suitable) and a good quality general purpose grease (grease that has a metal lubricant is preferred, if available).

- Remove wheels, clean wheel shaft (A, Fig. 4-1) and apply thin coating of grease to shaft.
- Grease back, front and sides of depth regulator lever (B, Fig. 4-1).
- Remove tines, clean tine shafts (C, Fig. 4-1) and inspect for rust, rough spots or burrs (especially around holes). File or sand smooth and coat ends of shaft with grease.
- Oil the threads on the handlebar height adjustment handle (D, Fig. 4-1).
- Oil the engine throttle cable (E, Fig. 4-1) and the wheel gear cable (F). Allow oil to soak in and then wipe off any excess.
- Oil the various pivot points (G, Fig. 4-2) on the shifting mechanism, the handlebar, and the idler arms (do not allow oil on the belts or pulleys).

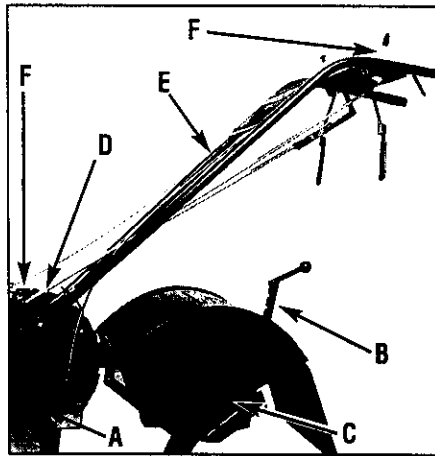

Figure 4-1

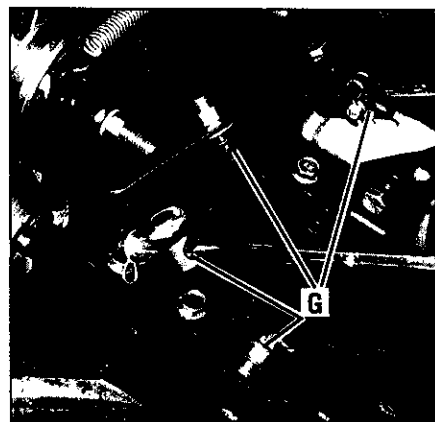

Figure 4-2



Figure 4-3

## Check For Oil Leaks

Before each use, check your tiller for signs of an oil leak – usually a dirty, oily accumulation either on the unit or on the floor where it has been parked.

A little seepage around a cover or oil seal is usually not a cause for alarm. However, if the oil drips overnight then immediate attention is needed as ignoring a leak can result in severe transmission damage.

If a cover is leaking, try tightening any loose screws or bolts. If the fasteners are tight, a new gasket or oil seal may be required. If the leak is from around a shaft and oil seal, the oil seal probably needs to be replaced. See your Sears Service Center for advice.

**IMPORTANT:** Never operate the tiller if the transmission is low on oil. Check the oil level after every 30 hours of operation and whenever there is any oil leakage.

## Check Hardware

At least every 10 operating hours, check the unit for loose or missing hardware (screws, bolts, nuts, hair-pin cotters, etc.). Loose or missing hardware can lead to equipment failure, poor performance, or oil leaks.

Be sure to check the end cap mounting screws located at the rear of the transmission (Figure 4-3). Lift the tine flap to service the screws.

# CUSTOMER RESPONSIBILITIES

**WARNING** Before inspecting, cleaning or servicing the unit, shut off engine, wait for all parts to come to a complete stop, disconnect spark plug wire and move wire away from spark plug. Failure to follow these instructions can result in serious personal injury or property damage.

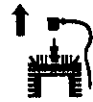

## Transmission Gear Oil Service

Check the transmission gear oil level every 30 hours of operation or when you notice any oil leak. Operating the tiller when the transmission is low on oil can cause severe damage.

### To Check Transmission Gear Oil Level

1. Check the gear oil level when the transmission is cool. Gear oil will expand in warm operating temperatures and this expansion will provide an incorrect oil level reading.
2. To check the gear oil level (and to add oil, if needed), see "STEP 4: Check Gear Oil Level in Transmission" in the Assembly Section of this manual.

### To Drain and Refill the Transmission

The transmission gear oil does not need to be changed unless contaminated with dirt, sand or metal bits.

1. Prop up the left side of the unit so that it will be securely supported when the left side wheel is removed. Remove the left side wheel by removing the wheel pin.
2. Unscrew the gear oil fill plug from the top of the transmission.
3. Place a clean pan below the transmission drain plug (see Figure 4-4) and remove the drain plug. The oil will start flowing out of the drain hole (it may flow slowly, especially in cold temperatures).
4. Remove the transmission gear oil level check plug located a few inches above the left side wheel shaft.
5. When the oil stops flowing, tilt the transmission forward to drain oil from the rear of the transmission.
6. After draining the oil, clean the threads of the drain plug, apply a non-hardening, removable gasket sealant to the threads, and securely reinstall the drain plug.
7. Using a clean funnel, slowly add SAE 140 or SAE 85W-140 weight gear oil (with an API rating of GL-4 only) to the transmission. The transmission holds approximately 3-1/4 pints (52-54 ounces). Tilt the tiller slightly backwards to make sure the

gear oil reaches the rear (tine) end of the transmission. Stop adding gear oil when it begins to flow from the oil level check hole on the side of the transmission.

8. Securely reinstall the check plug.
9. Securely reinstall the gear oil fill plug on top of the transmission.
10. Reinstall the wheel and remove the prop.



*Figure 4-4: Remove drain plug to drain transmission gear oil (also remove oil fill plug and oil level check plug).*

## Engine Oil Service

Check the engine oil level before starting the engine each day and check it after 5 hours of continuous operation. Running the engine when low on oil will quickly ruin the engine.

It is recommended that you change motor oil after every 10 hours of operation (sooner when operating in extremely dirty or dusty conditions.)

### To Check the Engine Oil Level

1. Move the tiller to a level area and shut off the engine.
2. Level the engine by putting the Depth Regulator Lever in the second notch from the top.
3. Clean the area around the oil dipstick or oil fill tube to prevent dirt from falling into the crankcase.
4. Remove the oil dipstick from the oil fill tube, wipe the dipstick clean, and reinstall it finger-tight. Remove the dipstick and check the reading. Add oil (if required) to bring the level to the FULL mark. Do not overfill.

## To Change the Engine Oil

Only use high quality detergent oil with an A.P.I. rating of service classification "SF", "SG", "SH" or "SH/CD." Select the oil SAE viscosity grade according to your expected operating temperature:

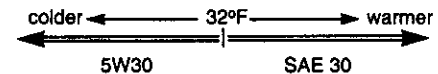

**NOTE:** Although multi-viscosity oils (5W30, 10W30, etc. improve starting in cold weather, these multi-viscosity oils will result in increased consumption when used above 32°F. Check your engine oil level more frequently to avoid possible engine damage from running low on oil. **DO NOT USE 10W40 OIL.**

1. Start engine and let it warm up. Then **TURN THE ENGINE OFF.**
2. There is an oil drain plug on each side of the engine base. Use whichever one is most convenient.
3. Place a 2"x4" wood board under the wheel opposite the drain plug you'll be removing.
4. Place a drain pan beneath the drain plug.
5. Remove the drain plug (Figure 4-5), and allow the old oil to drain completely.
6. Reinstall drain plug securely.
7. Remove wood board from beneath the wheel.
8. Remove the dipstick from the oil fill tube (see Figure 4-5). Using a funnel in the tube, refill the engine with the correct type and weight engine oil. Check the level frequently while filling so as not to overfill. Fill until oil is at the **FULL** mark on the dipstick. Install the dipstick.

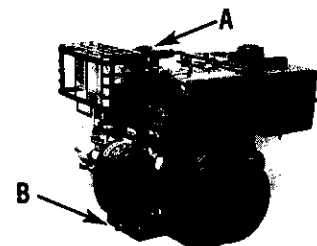

*Figure 4-5*



# CUSTOMER RESPONSIBILITIES



**WARNING** Before inspecting, cleaning or servicing the unit, shut off engine, wait for all parts to come to a complete stop, disconnect spark plug wire and move wire away from spark plug. Failure to follow these instructions can result in serious personal injury or property damage.



## Air Cleaner Service

The engine air cleaner filters dirt and dust out of the air before it enters the carburetor. Operating the engine with a dirty, clogged air filter can cause poor performance and damage to the engine. Never operate the engine without the air cleaner installed. Inspect and service the air cleaner more often if operating in very dusty or dirty conditions.

The air cleaner assembly is equipped with a foam filter and an inner paper filter. Service the filters according to the "Required Maintenance Schedule" on Page 22.

### To Service Filters:



Base Plate    Inner Paper Filter    Outer Foam Filter    Cover and Wing Nut

Figure 4-6: Air cleaner components.

### Outer Foam Filter—

- Wash in water and detergent solution and squeeze until all dirt is removed.
- Rinse thoroughly in clear water.
- Wrap in a clean cloth and squeeze until completely dry.
- Do not oil the foam filter.

### Inner Paper Filter—DO NOT ATTEMPT TO CLEAN OR OIL THIS FILTER.

- Replace annually or every 30 operating hours (more often under very dusty conditions).

### To Remove and Install Filters:

1. Remove wing nut and cover.
2. Slide foam filter off paper filter.
3. Discard paper filter.
4. Clean inside of base and cover thoroughly.
5. Install new paper filter on base.

6. Slide foam filter over paper filter.
7. Install cover and wing nut. Tighten wing nut securely.

## Spark Plug Service

Inspect and clean or replace the spark plug after every 100 operating hours or annually.

In some areas, local law requires using resistor spark plugs to suppress ignition signals. If the engine was originally equipped with a resistor spark plug, use the same type for replacement.

### To Service the Spark Plug

1. Clean area around spark plug.
2. Remove and inspect plug.
3. Replace plug if electrodes are pitted, burned, or porcelain is cracked. For replacement, use a Champion RJ-17LM only. **NOTE:** A resistor plug must be used for replacement.
4. Check electrode gap with wire feeler gauge and set gap at .030 if necessary.
5. Install spark plug and tighten securely.

## Spark Arrester Screen Service

If the engine muffler is equipped with a spark arrester screen, remove and clean away any accumulated material on the screen. Check to see that the screen is not burned through in any places or damaged. Replace a spark arrester screen if it is burned through or damaged in any location.

## Engine Cleaning

The engine must be kept clean to assure smooth operation and to prevent damage from overheating. The engine cooling fins (see Figure 4-6A) should not be allowed to accumulate any materials such as leaves, twigs, or other debris. All inspections and services must be done with the engine shut off and cool to the touch.

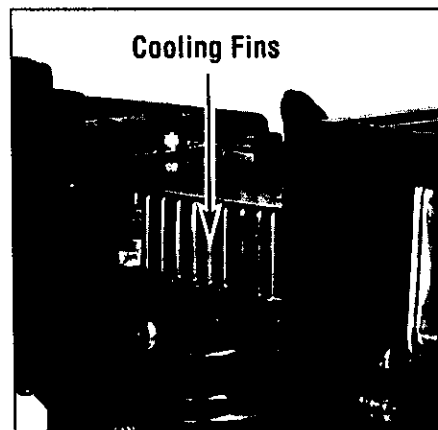

Figure 4-6A: Keep cooling fins clean.

## Carburetor/Governor Control Adjustments

The carburetor was adjusted at the factory for best operating speed. If an adjustment is needed, contact your nearest Sears Service Center.

The governor controls the maximum safe operating speed and protects the engine and all moving parts from damage caused by overspeeding. Do not tamper with the engine governor settings. Contact your nearest Sears Service Center if a problem exists.



### WARNING

Operators shall not tamper with the engine governor settings on the machine; the governor controls the maximum safe operating speed to protect the engine and all moving parts from damage caused by overspeed. Authorized service shall be sought if a problem exists.

## Throttle Control Adjustment

If the engine does not respond properly to various throttle lever settings, please contact your nearest Sears Service Center for assistance.

# SERVICE AND ADJUSTMENTS



**WARNING** Before inspecting, cleaning or servicing the unit, shut off engine, wait for all parts to come to a complete stop, disconnect spark plug wire and move wire away from spark plug. Failure to follow these instructions can result in serious personal injury or property damage.



## Wheel Gear Cable Adjustment

When the Wheel Gear Lever is in DISENGAGE, the wheels will roll freely (freewheel). The wheels should not roll freely when the lever is in ENGAGE. If the wheels roll freely when the Wheel Gear Lever is in ENGAGE, the wheel gear cable needs to be adjusted as described below.

1. With the engine shut off and the spark plug wire disconnected, put the Wheel Gear Lever in ENGAGE.
2. Loosen the top adjustment nut (A, Figure 4-7) on the wheel gear cable bracket that is located on the left side rear of the transmission.
3. Push the wheel gear cable (B) down and roll the tiller slightly forward or backward until the eccentric lever (C) engages (locks) the wheels. Hold the cable in that position and tighten the top (A) and bottom (D) adjustment nuts.
4. Move the Wheel Gear Lever to ENGAGE and DISENGAGE several times to check the adjustment. The wheels should not roll when the lever is in ENGAGE, but they should roll when the lever is in DISENGAGE. Readjust the cable as required.

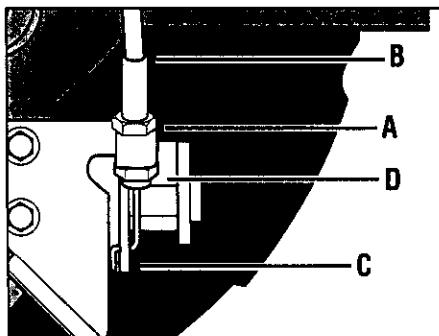

Figure 4-7: Wheel gear cable assembly.

## Tines

The tines will wear with use and should be inspected at the beginning of each tilling season and after every 30 operating hours. Tines can be replaced individually or as a complete set. Never inspect or service the tines unless the engine is stopped and the spark plug wire is disconnected.

**NOTE:** You must first remove the tiller hood in order to take off either a single tine holder or individual tines. The hood is secured to the transmission housing with two rear bolts and two front bolts. Remove all four bolts and set the hood aside to have full access to the tines.

### Tine Inspection

With use, the tines (Figure 4-8) will become shorter, narrower and pointed. Badly worn tines will result in a loss of tilling depth and reduced effectiveness when chopping up and turning under organic matter.



Figure 4-8: Check tines for wear after every 30 operating hours.

## Removing and Installing Tine Assemblies

1. Use a 9/16" socket, 6" extension, a ratchet, and a 9/16" box wrench to loosen the nut (A, Figure 4-9) and bolt (B) that secure the tine holder to the tine shaft.
2. Use a rubber mallet to tap the tine holder loose.
3. Slide the tine assembly off the tine shaft.
4. Repeat Steps 1-through-3 above to remove the other tine assembly.
5. Installing the tine assembly is simply the reverse of its removal. Be sure the cutting edges face so they will enter the soil first when the tiller is moving forward— this means the cutting edges face toward the operator position.

First be sure to remove any rust, uneven spots or burrs from the tine shaft, using fine sandpaper. Then grease the tine shaft before reinstalling the tine assemblies. Tighten the hardware very securely.

## Removing and Installing Individual Tines

1. Use two 9/16" box end wrenches to remove the two bolts (C, Figure 4-9), and nuts (D) that secure the tine to its tine holder. See Figure 4-9.

**NOTE:** If the nuts are rusted, apply penetrating oil to the bolt and nut. Let the oil soak in for a few minutes before loosening the nut. Always loosen the nut rather than the bolt.

2. When installing individual tines, install them in the reverse order from which they were removed. The two sets of *inboard* tines are installed so one set faces toward the transmission housing and the other faces away from it. The single *outboard* tine set faces toward the transmission housing. Also be sure the cutting edges face so they will enter the soil first when the tiller is moving forward— this means the cutting edges face toward the operator position.

# SERVICE AND ADJUSTMENTS

**WARNING** Before inspecting, cleaning or servicing the unit, shut off engine, wait for all parts to come to a complete stop, disconnect spark plug wire and move wire away from spark plug. Failure to follow these instructions can result in serious personal injury or property damage.



## WARNING

This is a CRT (counter-rotating tine) tiller and its tines must be mounted in the direction shown in Figure 4-9. If mounted with curves in the opposite direction, tiller will dig poorly and be more likely to run backwards.

Failure to comply could result in personal injury or property damage.

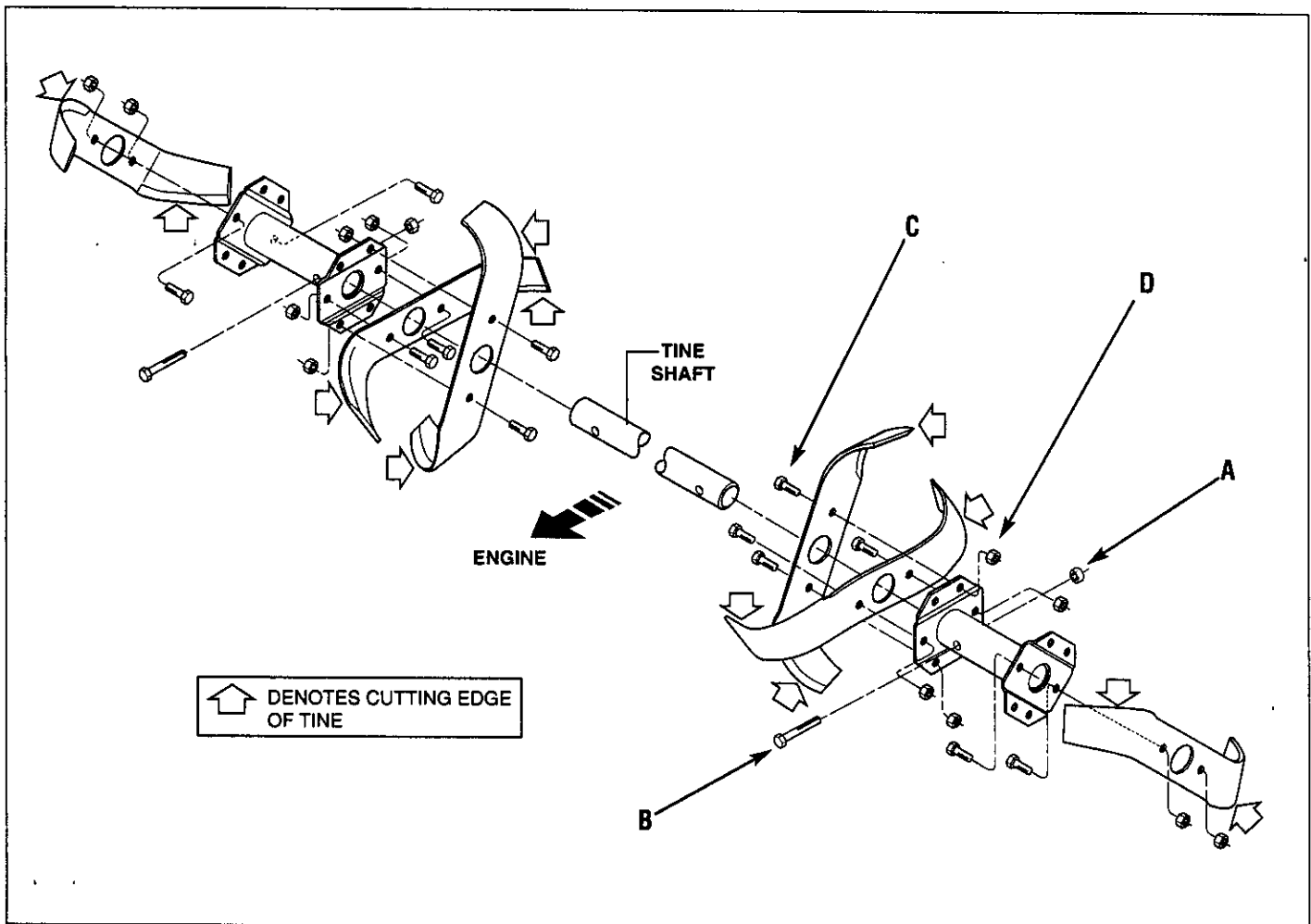

Figure 4-9: Complete tine assemblies: tine holders, all tines and hardware.

# SERVICE AND ADJUSTMENTS

**WARNING** Before inspecting, cleaning or servicing the unit, shut off engine, wait for all parts to come to a complete stop, disconnect spark plug wire and move wire away from spark plug. Failure to follow these instructions can result in serious personal injury or property damage.



## Checking And Adjusting The Tension On The Drive Belts

Maintaining correct tension on the drive belts is important to good tilling performance and long belt life. A loose belt will slip on the engine and transmission pulleys and cause the tines and wheels to slow down – or stop completely – even though the engine is running at full speed. A loose belt will also result in premature wear to the belt.

While checking belt tension, also check for cracks, cuts or frayed edges. A belt that is in poor condition should be replaced.

The tension on a new forward drive belt should be checked after the first two (2) hours of operation. Thereafter, check the tension after every ten (10) hours of operation.

The reverse drive belt, because it is used more sparingly, will probably not require an initial tension adjustment until a significant number of operating hours has passed.

## WARNING

Follow the belt adjustment instructions carefully. An incorrect adjustment could result in the Forward Clutch mechanism engaging too soon. This could cause loss of tiller control and result in personal injury or property damage.

### To Check and Adjust Tension on the Forward Drive Belt:

1. The check for correct belt tension is the same as that described in Step 5 of "Step 3: Attach Forward Clutch Rod" on page 9. Before performing this check, shut off the engine, disconnect the spark plug wire, and allow the engine and muffler to cool down. If, after following the adjustment procedures, you cannot get the correct gap on the forward clutch rod

adjustment bracket, you will need to make a secondary adjustment as described next.

2. Disconnect the Forward Clutch Rod (A, Figure 4-10) from the swivel plate (B) by removing the innermost hairpin cotter (C).

3. Unthread the Forward Clutch Rod (in a counterclockwise direction as viewed from the front of the unit) until one or two threads on the rod extend above the rectangular nut (D, Figure 4-11) on the forward clutch bracket.

4. Remove the belt cover.

5. From the right side of the unit, slip the forward drive belt (E, Figure 4-10) out of the pulley groove closest to the engine (this forward drive pulley has two grooves) by pushing it off (away from the engine) with your left hand while pulling the engine starter rope with your right hand. (The forward drive belt should have been located in the pulley groove closest to the engine; not in the groove furthest from the engine.)

6. On the left side of the unit (as viewed from operator's position) remove the hairpin cotter from the clevis pin (F, Figure 4-12) that connects the forward idler arm (G) to the forward adjustable link (H). Push inward on the forward idler arm (G) and remove the clevis pin (F).

7. There are two holes in the forward adjustable link (H, Figure 4-12). Push inward on the forward idler arm (G) and install the clevis pin (F) through the inner hole in the forward adjustable link (H) and out through the single hole in the forward idler arm (G). Secure the clevis pin with the hairpin cotter.

**NOTE:** While pushing inward on the forward idler arm, be sure that the forward drive belt is moved off to the right side of the tiller. This creates more room to install the clevis pin when the forward idler arm is pushed inward.

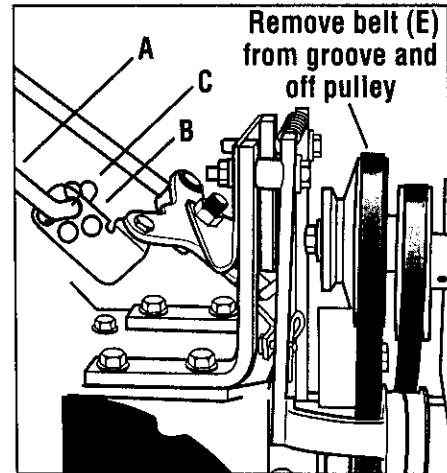

Figure 4-10: Disconnect Forward Clutch Rod and move forward drive belt out of groove in engine forward drive pulley.

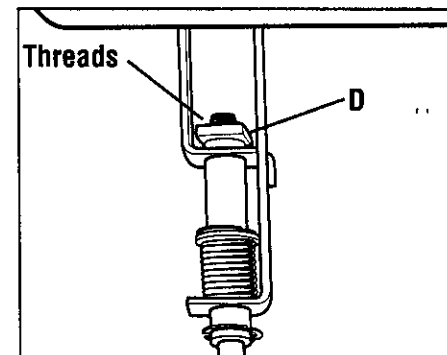

Figure 4-11 One or two threads on Forward Clutch Rod should be exposed above rectangular nut.

**IMPORTANT:** With the clevis pin installed in the inner hole of the forward adjustable link, the number of additional belt tension adjustments that can be made is limited. If, with future tension adjustments, you find that you cannot screw the forward clutch rod any farther into the rectangular nut on the forward clutch bracket, it means that the forward drive belt must be replaced. Before doing so, the clevis pin must be returned to the OUTSIDE hole in the forward adjustable link.

# SERVICE AND ADJUSTMENTS



**WARNING** Before inspecting, cleaning or servicing the unit, shut off engine, wait for all parts to come to a complete stop, disconnect spark plug wire and move wire away from spark plug. Failure to follow these instructions can result in serious personal injury or property damage.

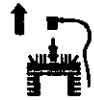

8. Replace the forward drive belt in the High speed groove of the engine drive pulley (the groove closest to the engine) and in the middle groove in the transmission pulley. Be sure the belt is to the inside of the wire formed belt guide (I, Figure 4-13) and to the inside of the forward drive idler pulley (J).

9. Reinstall the belt cover and secure it with the two nuts.

10. Readjust the forward drive belt tension by following the instructions in item 5 of "Step 3: Attach Forward Clutch Rod" on Page 9.

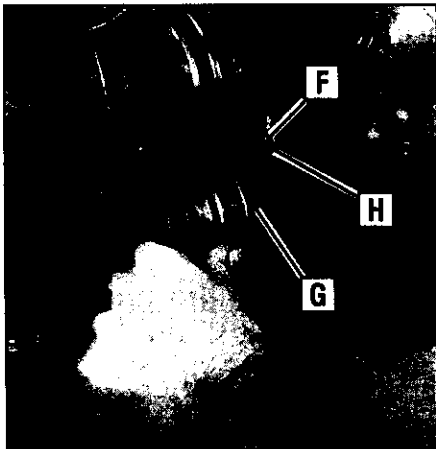

Figure 4-12: Remove clevis pin from outer hole in forward adjustable link and move to inner hole in link.

## To Check and Adjust Tension on the Reverse Drive Belt

1. Remove the belt cover after first shutting off the engine, disconnecting the spark plug wire, and allowing the engine and muffler to cool down.

2. Stand at the front of the tiller and use your left hand to push the reverse idler arm (K, Figure 4-14) inward as far as possible (the reverse idler pulley [L] is attached to the reverse idler arm). Hold the idler arm in this position and look at the position of the belt tension guide mark (M, Figure 4-15) that is stamped into the face of the reverse adjustable link (N, Figure 4-15).

• The belt tension is correct if the guide mark (M, Figure 4-15) is anywhere to the left of the guide pin (O), as viewed from the front of the unit (not the operator's position). If the belt tension is correct, reinstall the belt cover and secure it with the two nuts.

• If the guide mark is aligned with the guide pin, or moves to the right side of the guide pin, then the belt is too loose and the tension must be readjusted as described next.

3. The reverse idler pulley (L, Figure 4-14) regulates the tension that is applied to the reverse drive belt (P). The following adjustment will allow the reverse idler pulley to apply more tension to a loose belt.

4. Remove the belt cover.

5. Slip the reverse belt (P, Figure 4-14) off the engine driven reverse (upper) pulley.

6. On the right side of the unit (as viewed from operator's position) remove the hairpin cotter from the clevis pin (R, Figure 4-14) that connects the reverse idler arm (K) to the reverse adjustable link. Push inward on the reverse idler arm (K) and remove the clevis pin (R).

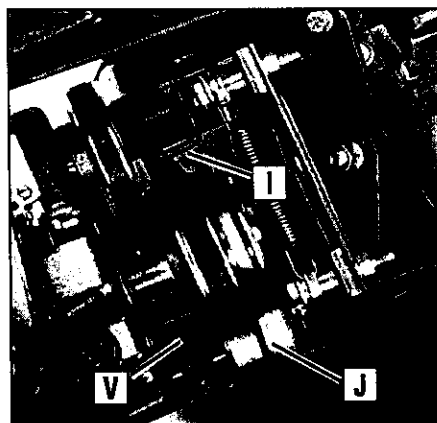

Figure 4-13: Top view of belts and pulleys.

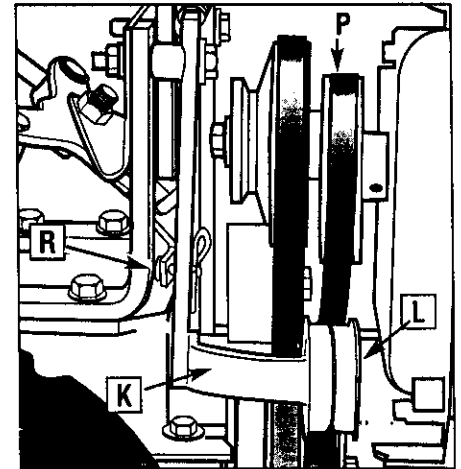

Figure 4-14 : Reverse idler arm (K) and reverse pulley (L).

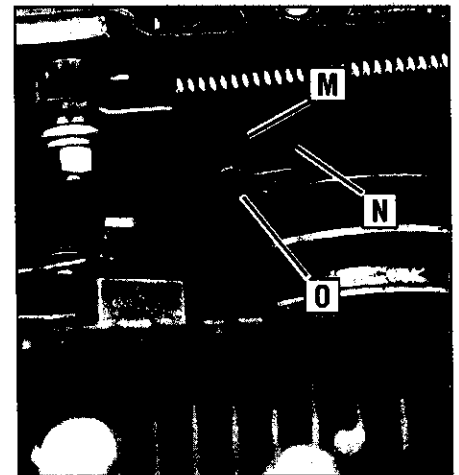

Figure 4-15: While pushing reverse idler arm inward, stand at engine end and check position of guide mark (M) and guide pin (O).

# SERVICE AND ADJUSTMENTS

**WARNING** Before inspecting, cleaning or servicing the unit, shut off engine, wait for all parts to come to a complete stop, disconnect spark plug wire and move wire away from spark plug. Failure to follow these instructions can result in serious personal injury or property damage.



7. There are two holes in the reverse adjustable link (S, Figure 4-16). Push inward on the reverse idler arm (K) and install the clevis pin (R) through the inner hole in the reverse adjustable link (S) and out through the single hole in the reverse idler arm (K). Secure the clevis pin with the hairpin cotter.

8. Reinstall the reverse belt (P, Figure 4-14) on the reverse (upper) pulley, making sure the belt is located to the inside of the reverse idler pulley (L, Figure 4-14).

9. Reinstall the belt cover and secure it with the two nuts.

**IMPORTANT:** If, in future tests for reverse belt tension, the guide mark should again align with or move to the right side of the guide pin, it means that the reverse belt is worn beyond adjustment. Before installing a new belt, you must return the clevis pin to the OUTSIDE hole in the reverse adjustable link.

## Forward Drive Belt Removal And Installation

**NOTE:** This model has one forward speed (High) and one reverse speed. The High Speed groove in the forward engine pulley (the groove closest to the engine) is the only groove that should be used in this pulley. Do not use the groove in the forward engine pulley that is furthest from the engine. The reverse pulley has just one groove. The transmission pulley has three grooves—do not use the groove closest to the transmission housing.

### Removing the Forward Drive Belt:

1. Stop the engine, allow it to cool and disconnect the spark plug wire before working near the belts.
2. Remove the reverse drive belt completely (A, Figure 4-17) by following the "Removing the Reverse Drive Belt" instructions in this section.
3. Move the forward drive belt (B, Figure 4-17) completely off the engine forward drive pulley (D).
4. Slip the forward drive belt completely off the transmission drive pulley (C, Figure 4-17) by moving it to the front of the pulley.
5. Pull the forward drive belt up and away by feeding the bottom half of the belt in between the engine and transmission pulleys.

### Installing the Forward Drive Belt:

1. The reverse drive belt must be removed before installing the forward drive belt.
2. Slip the forward drive belt down between the rear of the engine forward drive pulley (D, Figure 4-17) and feed the bottom half in between the engine and transmission pulleys (see Figure 4-18). Be sure that the belt is to the inside of the forward idler pulley and forward belt guide (see J and I, Figure 4-13).
3. Slip the forward drive belt down and over the front of the transmission pulley (C, Figure 4-17).

**NOTE:** For additional working room, loosen the reverse belt guide (V, Figure 4-13) and twist it out of the way.

4. Put the lower half of the belt into the middle groove of the transmission pulley (C, Figure 4-17).

5. Put the upper half of the belt on the engine forward drive pulley in the groove closest to the engine (B, Figure 4-17).

**IMPORTANT:** Make sure that the forward drive belt is to the inside of the wire belt guide (I, Figure 4-13) and the forward idler pulley (J, Figure 4-13).

6. If you loosened the belt guide, wait until the reverse drive belt is installed before securing the belt guide.
7. Install the reverse drive belt.
8. Install the belt cover and secure it with the two nuts.
9. If you installed a new belt, check the tension after two hours of operation.

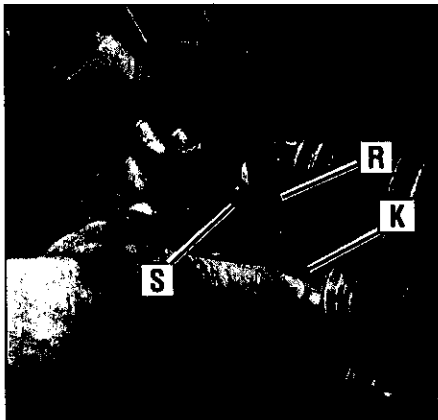

Figure 4-16: Installing clevis pin in inside hole of reverse adjustable link.

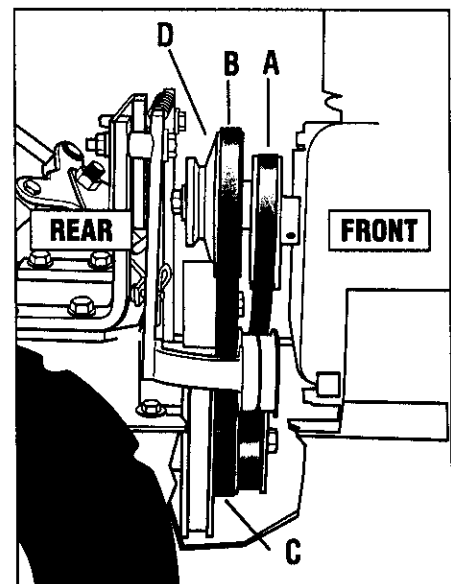

Figure 4-17: Belt drive system.

# SERVICE AND ADJUSTMENTS



**WARNING** Before inspecting, cleaning or servicing the unit, shut off engine, wait for all parts to come to a complete stop, disconnect spark plug wire and move wire away from spark plug. Failure to follow these instructions can result in serious personal injury or property damage.

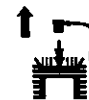

Figure 4-18: Install forward drive belt over rear of engine forward pulley and bring lower half of belt down and in front of transmission pulley.

## Reverse Drive Belt Removal and Installation

**NOTE:** The forward drive belt must be installed before installing the reverse drive belt.

### Removing the Reverse Drive Belt

1. Stop the engine and allow it to cool before working near the belts. Be sure the spark plug wire is disconnected.
2. Remove the belt cover by removing the two nuts. For easier access to the transmission (lower) pulley, remove the transmission cover located below the transmission pulley.
3. Slip the reverse belt off the engine reverse pulley (A, Figure 4-19). If necessary, work the belt off the pulley with your left hand while pulling the engine recoil starter rope with your right hand.
4. Push the upper half of the reverse belt downward to create slack in the belt. Then reach underneath the transmission and slip the belt off the front of the transmission pulley (B, Figure 4-19).
5. Pull the belt up and past the engine reverse pulley (A, Figure 4-19).

### Installing the Reverse Drive Belt

1. Slip the reverse belt down between the engine reverse pulley (A, Figure 4-19) and the engine forward drive pulley (C).
2. Loop the bottom half of the belt over the front of the transmission pulley (B, Figure 4-19) and seat the belt in the front groove of the pulley.
3. Place the belt to the inside of the reverse idler pulley (D, Figure 4-19) and the reverse belt guide (V, Figure 4-13). Then slip the upper end into the groove of the engine reverse pulley (A, Figure 4-19).
4. If the reverse belt guide (V, Figure 4-13) was loosened previously, center the belt guide on the belt and tighten the mounting screw securely.
5. Install the belt cover and secure it with the two nuts. If the lower transmission cover was removed, reinstall it with the four self-tapping screws.

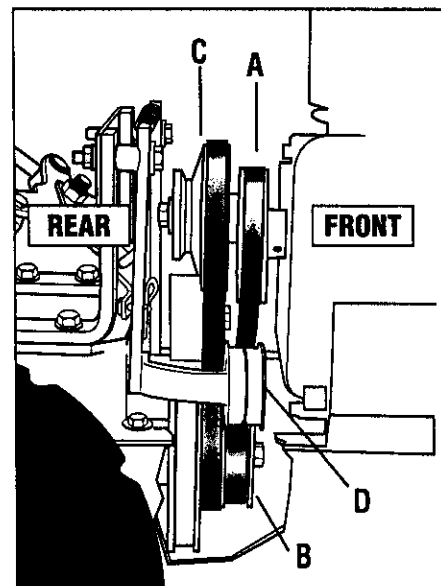

Figure 4-19: Removing and installing reverse belt.

---

# STORAGE

---

## Tiller Storage

Whenever you don't intend to use your tiller for 30 days or longer, you should perform the following steps to ensure that it will start easily and perform properly when removed from storage.

- Thoroughly clean the machine.
- Be sure that all nuts, bolts and screws are securely fastened. Inspect parts for damage, breakage or wear. Replace as necessary.
- Touch up all rusted or chipped paint surfaces. Sand lightly before repainting.
- If possible, store your unit indoors and cover it with a suitable protective cover (not plastic) that does not retain moisture.

**IMPORTANT:** Never cover the unit while the engine and exhaust areas are still warm.

- Do not store gasoline from one season to another.
- Replace your gasoline can if it starts to rust. Rust and/or dirt in your gasoline will cause problems.

## Engine Storage

### Fuel System

**IMPORTANT:** It is important to prevent gum deposits from forming in essential fuel system parts such as carburetor, fuel filter, fuel hose, or tank during storage. Also, experience indicates that alcohol blended fuels (called gasohol or using ethanol or methanol) can attract moisture which leads to separation and formation of acids during storage. Acidic gas can damage the fuel system of an engine while in storage.



## DANGER

Gasoline is highly flammable and its vapors are explosive. Follow these safety practices to prevent injury or property damage from fire or explosion.

- Let engine and muffler cool at least 2 minutes before draining fuel tank.
- Do not allow open flames, sparks, or matches, or permit smoking in fueling area.
- Wipe up spills and push the tiller away from spilled fuel.
- Use only an approved fuel container and store it safely from children.
- Do not store gasoline in an area where its vapors could reach an open flame or spark, or where ignition sources are near (such as hot water and space heaters, furnaces, clothes dryers, stoves, motors, etc.)

- Drain the fuel tank.
- Start the engine and let it run until the fuel lines and carburetor are empty.
- Never use engine or carburetor cleaner products in the fuel tank or permanent damage may occur.
- Use fresh fuel next season.

**NOTE:** If "Gasohol" has been used, run engine until the tank is empty. Then put 1/2 pint of "Unleaded" regular gasoline into the fuel tank and again run the engine until tank is empty.

**NOTE:** Fuel stabilizer (such as Craftsman Fuel Stabilizer No. 33550) is an acceptable alternative in minimizing the formation of fuel gum deposits during storage. Add stabilizer to gasoline in fuel tank or storage container. Always follow the mix ratio and instructions on the stabilizer container. Run engine at least 10 minutes after adding stabilizer to allow the stabilizer to reach the carburetor. Do not drain the gas tank and carburetor if using fuel stabilizer

### Engine Oil

Drain oil and replace with clean engine oil. See "Engine Lubrication" in the CUSTOMER RESPONSIBILITIES section.

### Engine Cylinder

- Remove spark plug. Squirt one (1) oz. (30ml) of clean engine oil into spark plug hole.
- Cover spark plug hole with a clean rag.
- Pull starter rope to crank engine over, slowly, several times.
- Install spark plug. Do not connect spark plug wire.



# TROUBLESHOOTING

## TROUBLESHOOTING

Before performing any corrections, refer to the appropriate information in this Manual for the correct safety precautions and operating or maintenance procedures. Contact your local Sears Service Center for necessary service.

PROBLEM	POSSIBLE CAUSE	CORRECTION
<b>Engine does not start.</b>	<ol style="list-style-type: none"> <li>1. Spark plug wire disconnected.</li> <li>2. Engine Throttle Control Lever incorrectly set.</li> <li>3. Fuel tank empty.</li> <li>4. Choke control (if so equipped) in incorrect position.</li> <li>5. Stale gasoline.</li> <li>6. Dirty air filter(s).</li> <li>7. Defective or incorrectly gapped spark plug.</li> <li>8. Carburetor out of adjustment.</li> <li>9. Misadjusted throttle control cable.</li> <li>10. Dirt or water in fuel tank.</li> </ol>	<ol style="list-style-type: none"> <li>1. Reconnect wire.</li> <li>2. Put lever in START position.</li> <li>3. Add fuel.</li> <li>4. Move lever to correct position.</li> <li>5. Drain fuel and add fresh fuel.</li> <li>6. Clean or replace filter(s).</li> <li>7. Inspect spark plug.</li> <li>8. Contact Sears Service Center.</li> <li>9. Contact Sears Service Center.</li> <li>10. Contact Sears Service Center.</li> </ol>
<b>Engine runs poorly.</b>	<ol style="list-style-type: none"> <li>1. Defective or incorrectly gapped spark plug.</li> <li>2. Dirty air filter(s).</li> <li>3. Carburetor out of adjustment.</li> <li>4. Stale gasoline.</li> <li>5. Dirt or water in fuel tank.</li> <li>6. Engine cooling system clogged.</li> </ol>	<ol style="list-style-type: none"> <li>1. Inspect spark plug (see "Customer Responsibilities").</li> <li>2. Clean or replace (see "Customer Responsibilities").</li> <li>3. Contact Sears Service Center.</li> <li>4. Replace with fresh gasoline.</li> <li>5. Contact Sears Service Center.</li> <li>6. Clean air cooling system (see "Customer Responsibilities").</li> </ol>
<b>Engine overheats.</b>	<ol style="list-style-type: none"> <li>1. Engine cooling system clogged.</li> <li>2. Carburetor out of adjustment.</li> <li>3. Oil level is low.</li> </ol>	<ol style="list-style-type: none"> <li>1. Clean air cooling area (see "Customer Responsibilities").</li> <li>2. Contact Sears Service Center.</li> <li>3. Check oil level (see "Customer Responsibilities").</li> </ol>
<b>Engine does not shut off.</b>	<ol style="list-style-type: none"> <li>1. Misadjusted throttle control cable.</li> </ol>	<ol style="list-style-type: none"> <li>1. Contact Sears Service Center.</li> </ol>
<b>Wheels and Tines will not turn.</b>	<ol style="list-style-type: none"> <li>1. Improper use of controls.</li> <li>2. Forward Drive: Misadjusted forward clutch rod.</li> <li>3. Reverse Drive: Broken or misadjusted belt.</li> <li>4. Worn, broken, or misadjusted drive belt(s).</li> <li>5. Internal transmission wear or damage.</li> <li>6. Bolt and key loose in transmission pulley.</li> </ol>	<ol style="list-style-type: none"> <li>1. Review "Operation" section.</li> <li>2. See "Handlebar Height Adjustment" in "Operation" section.</li> <li>3. Replace belt or adjust belt tension (see "Service and Adjustments" section).</li> <li>4. See "Checking Drive Belt Tension (see "Service and Adjustments" section).</li> <li>5. Contact Sears Service Center.</li> <li>6. Tighten bolt; check that key is in place.</li> </ol>
<b>Tines turn, but wheels don't.</b>	<ol style="list-style-type: none"> <li>1. Wheel mounting hardware missing.</li> <li>2. Internal transmission wear or damage.</li> <li>3. Misadjusted wheel gear cable.</li> <li>4. Wheel Gear Lever not fully engaged.</li> </ol>	<ol style="list-style-type: none"> <li>1. Replace hardware.</li> <li>2. Contact Sears Service Center.</li> <li>3. See "Wheel Gear Cable Adjustment" in "Service and Adjustments" section.</li> <li>4. Engage lever (see "Operation" section).</li> </ol>
<b>Wheels Turn, but Tines Don't.</b>	<ol style="list-style-type: none"> <li>1. Tine holder mounting hardware missing.</li> <li>2. Internal transmission wear or damage.</li> </ol>	<ol style="list-style-type: none"> <li>1. Replace hardware.</li> <li>2. Contact Sears Service Center.</li> </ol>
<b>Poor tilling performance.</b>	<ol style="list-style-type: none"> <li>1. Worn tines.</li> <li>2. Improper Depth Regulator setting.</li> <li>3. Incorrect throttle setting.</li> <li>4. Belt(s) slipping.</li> </ol>	<ol style="list-style-type: none"> <li>1. See "Tines" in "Service and Adjustments" section.</li> <li>2. See "Tilling Tips &amp; Techniques" in "Operation" Section.</li> <li>3. See "Operation" Section.</li> <li>4. See "Checking Drive Belt Tension" in "Service and Adjustments" section.</li> </ol>

# OPERATING AND SAFETY DECALS

A.

For a replacement owner's manual or decals, contact your local Sears Service Center or Sears Retail Store.

Sears, Roebuck and Co.  
Hoffman Estates, IL 60179 USA

1909942 (3/05)

E.

**CRAFTSMAN**

- Use Forward Clutch (left paddles) up to engage Tines and Wheels for regular forward tilling.
- Use Reverse Clutch to engage Tines and Wheels in a reverse direction. (Do not fill in reverse.)
- To STOP Tines and Wheels, LET GO of all controls.

WHEEL GEAR

REVERSE CLUTCH

ENGINE THROTTLE

B.

Keep away from rotating tines. Rotating tines will cause injury.

1911361.A (1/98)

C.

PLACE FREE HAND HERE WHEN MANUALLY STARTING ENGINE.

1915810 (12/97)

F.

**WARNING**

Hot surfaces can cause severe burns. Do not touch muffler or adjacent areas.

1904549 Rev A

D.

**IMPORTANT:** Read Owner's Manual before starting or operating this machine. A replacement Owner's Manual is available upon request.

To Avoid Serious Injury:

- Read the Operator's Manual.
- Know the location and functions of all controls.
- Keep all safety devices and shields in place and working.
- Never allow children or un instructed adults to operate machine.
- Shut off engine and disconnect spark plug wire before manually unlogging tines or making repairs.
- Keep bystanders away from machine.
- Keep away from rotating parts.
- Use extreme caution when reversing or pulling the machine towards you.

Serious Injury Can Result Due To Loss of Tiller Control or Contact with Rotating Tines. To Help Avoid Serious Injury:

- When wheels are in "FREEWHEEL" position, tiller can be propelled rapidly by the tines. This can result in loss of control and serious injury. Do not put tines in soil when wheels are in "FREEWHEEL" or when Wheel Gear Lever (if so equipped) is in "DISENGAGE" position.
- Tiller may jump or bounce unexpectedly in hard ground or if tines contact buried objects. This can result in loss of control and serious injury. If loss of control occurs, let go of tiller and all controls.
- Before starting engine, inspect the anti-reverse mechanism (if so equipped) for proper function.

Ref. Letter	Part #	Description and Location	Qty.
A	1909942	Owner's Manual Replacement .....	1
B	1911361	WARNING-- Keep Away From Tines .....	1
C	1915810	Starting Stabilization Instructions .....	1
D	1904547	Hood Decal .....	1
E	1916812	Control Panel .....	1
F	1904549	WARNING--Hot Surface .....	1

# CRAFTSMAN 8HP MODEL 987.293330 REPAIR PARTS

## FORWARD/REVERSE IDLER ASSEMBLY

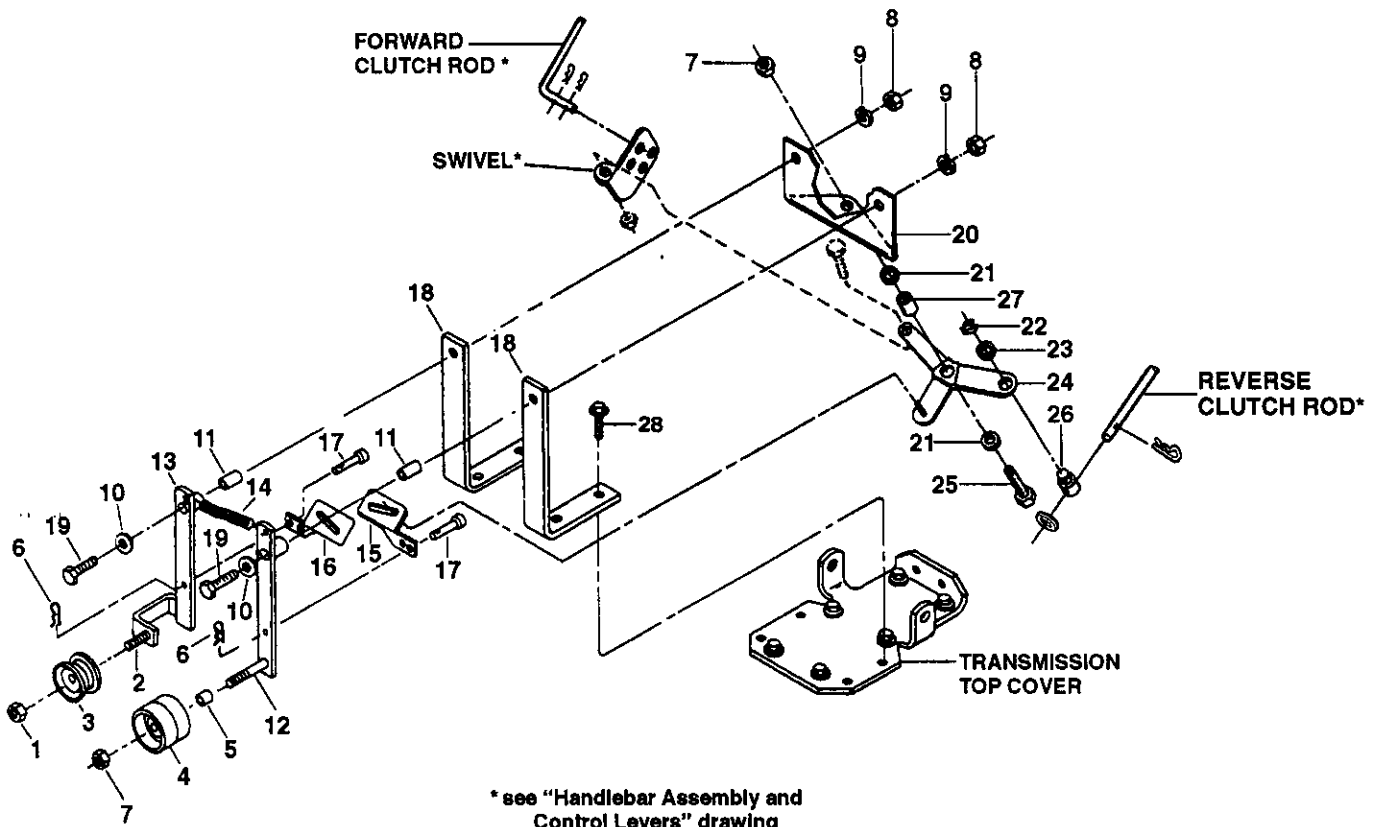

REF No.	PART No.	DESCRIPTION	QTY.
1	1185506	Locknut-hex, 3/8-16.....	1
2	1110043	Screw-hex hd, 3/8-16 x 1-1/4**...	1
3	1909266	Pulley-idler, reverse tiller direction	1
4	9193	Pulley-idler, forward tiller direction	1
5	1113-1	Spacer.....	1
6	9338	Hairpin Cotter.....	2
7	1110108	Locknut-hex, 3/8-16.....	2
8	1186230	Nut-hex, 5/16-18.....	2
9	1100242	Lockwasher-5/16.....	2
10	20545	Washer-plain, 5/16.....	2
11	9479	Pivot Bushing.....	2
12	1916192001	Idler Arm-left, forward tiller direction.....	1
13	1909682001	Idler Arm-right, reverse tiller direction.....	1
14	1492	Spring.....	1
15	20517-01	Forward Link.....	1

REF No.	PART No.	DESCRIPTION	QTY.
16	20517-02	Reverse Link.....	1
17	9340	Pin.....	2
18	1916194001	Mounting Bar.....	2
19	1111607	Screw-hex hd., 5/16-18 x 2-1/4**...	2
20	1916195001	Shifting Base.....	1
21	20553	Spacer-Bushing.....	2
22	9532	Klip Ring.....	1
23	20546	Washer-pivot.....	1
24	1916196001	Bellcrank.....	1
25	1100043	Screw-hex hd., 3/8-16 x 1-1/4**..	1
26	1916897	Pivot-for Reverse Clutch lever.....	1
27	20532	Bushing-bellcrank.....	1
28	1186331	Screw-flanged hex hd., 5/16-18 x 1*.....	4

\*\* Specify GRADE 5 if ordering part locally.

# CRAFTSMAN 8HP MODEL 987.293330 REPAIR PARTS

## HANDLEBAR ASSEMBLY & CONTROL LEVERS

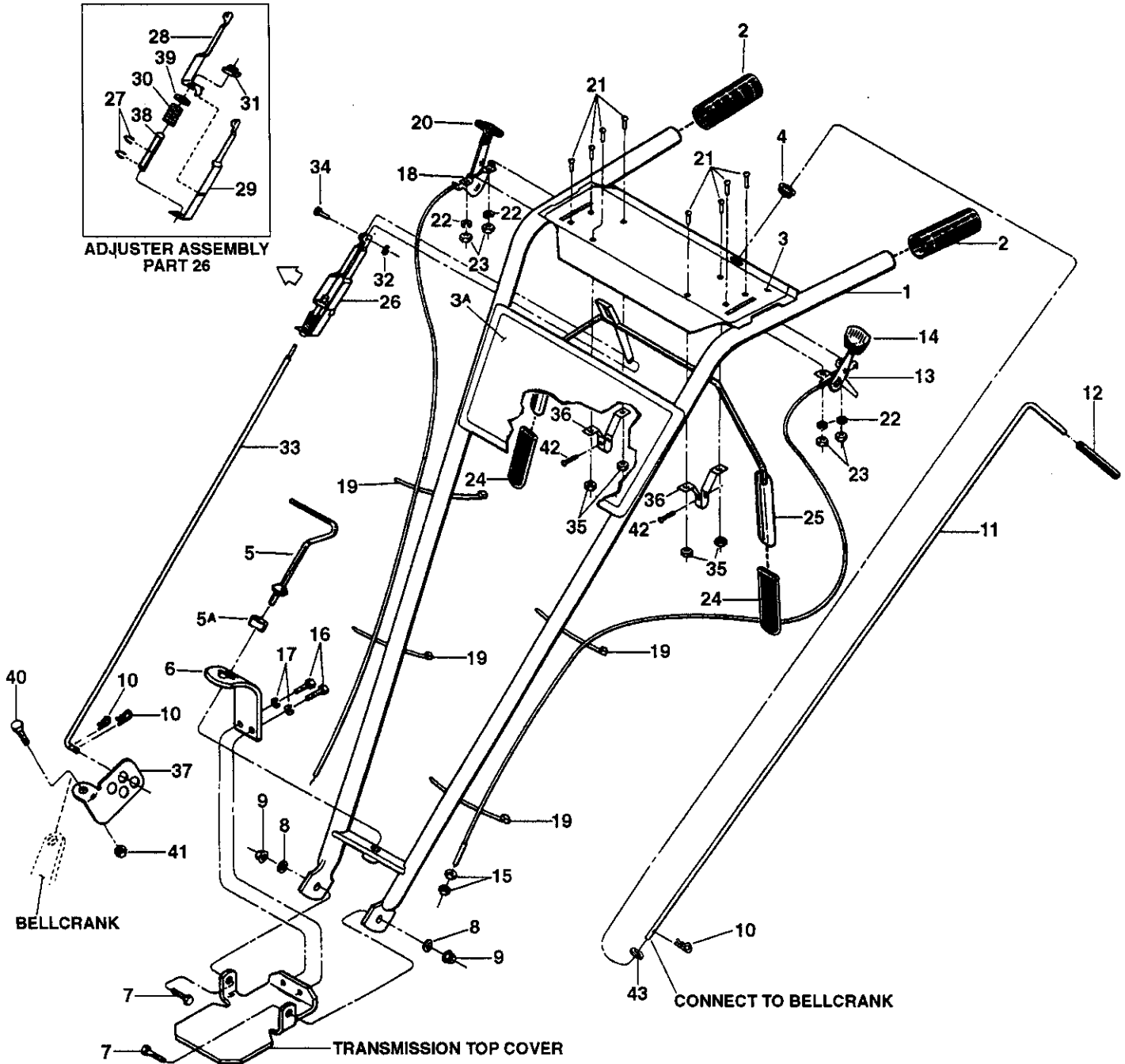

# CRAFTSMAN 8HP MODEL 987.293330 REPAIR PARTS

## HANDLEBAR ASSEMBLY & CONTROL LEVERS

REF No.	PART No.	DESCRIPTION	QTY.
1	1916766	Handlebars--(incl. Ref. No.'s 2, 3, 3A and 4) .....	1
2	9126	Grip--handlebars .....	2
3	1916812	Decal-- for operator control panel ..	1
3A	1916810	Decal-- Logo .....	1
4	9251	Grommet--plastic (part of operator control panel).....	1
5	20703	Handle, height adjustment.....	1
5A	9955	Washer--keyed .....	1
6	1900475001	Bracket--handlebar height adjust ...	1
7	1100046	Screw--hex hd., 3/8-16 x 1* .....	2
8	9904	Washer--plain (flat) 3/8, S.A.E.....	2
9	9837	Locknut--hex, 3/8-16 .....	2
10	9338	Hair Pin Cotter .....	3
11	1916896	Reverse Clutch Lever--complete (incl. grip, #9198).....	1
12	9198	Grip--reverse clutch lever.....	1
13	1916639	Wheel Gear Control & Cable Assy. ....	1
14	9057	Knob--wheel gear control lever .....	1
15	1186211	Nut--hex, 5/16-24, wheel gear cable adjustment.....	2
16	1100068	Screw--hex hd., 3/8-16 x 3/4* .....	2
17	1100243	Lockwasher--3/8 .....	2
18	9445	Engine Throttle Control & Cable ....	2
19	9202	Ties--plastic.....	4
20	9212	Knob--throttle control lever.....	1
21	1114748	Screw--round hd, No. 10-32 x 1/2 .	8
22	1100240	Lockwasher--No. 10.....	4

REF No.	PART No.	DESCRIPTION	QTY.
23	1186208	Nut--hex, No. 10-32 .....	4
24	9390	Grip--paddle .....	2
25	20863	Bail--forward clutch control (incl. two Grips, Ref. No. 24) .....	1
26	20862	Adjuster Assembly (incl. Ref. No.'s 27, 28, 29, 30, 38 and 39).....	1
27	9532	Klip Ring.....	2
28	20808	Adjuster, Right Side.....	1
29	20809	Adjuster, Left Side .....	1
30	9059	Spring--Adjuster.....	1
31	9522	Nut--rectangular.....	1
32	9386	Klip Ring.....	1
33	20831	Rod--forward clutch.....	1
34	97083	Pin--Clevis.....	1
35	9853	Sems Nut.....	4
36	20806	Bracket--bail support.....	2
37	20888	Swivel.....	1
38	9432	Bushing .....	1
39	9973	Washer .....	1
40	1100805	Screw--hex hd., 1/4-20 x 3/4* .....	1
41	9811	Nut--1/4-20 .....	1
42	9552	Screw--flanged hex hd, self-tapping, 1/4-20 x 1/2* .....	2
43	20545	Washer-- flat, 5/16" .....	1

\* Specify GRADE 5 if ordering part locally.

# CRAFTSMAN 8HP MODEL 987.293330 REPAIR PARTS

## HOOD, BRACKET & DEPTH REGULATOR

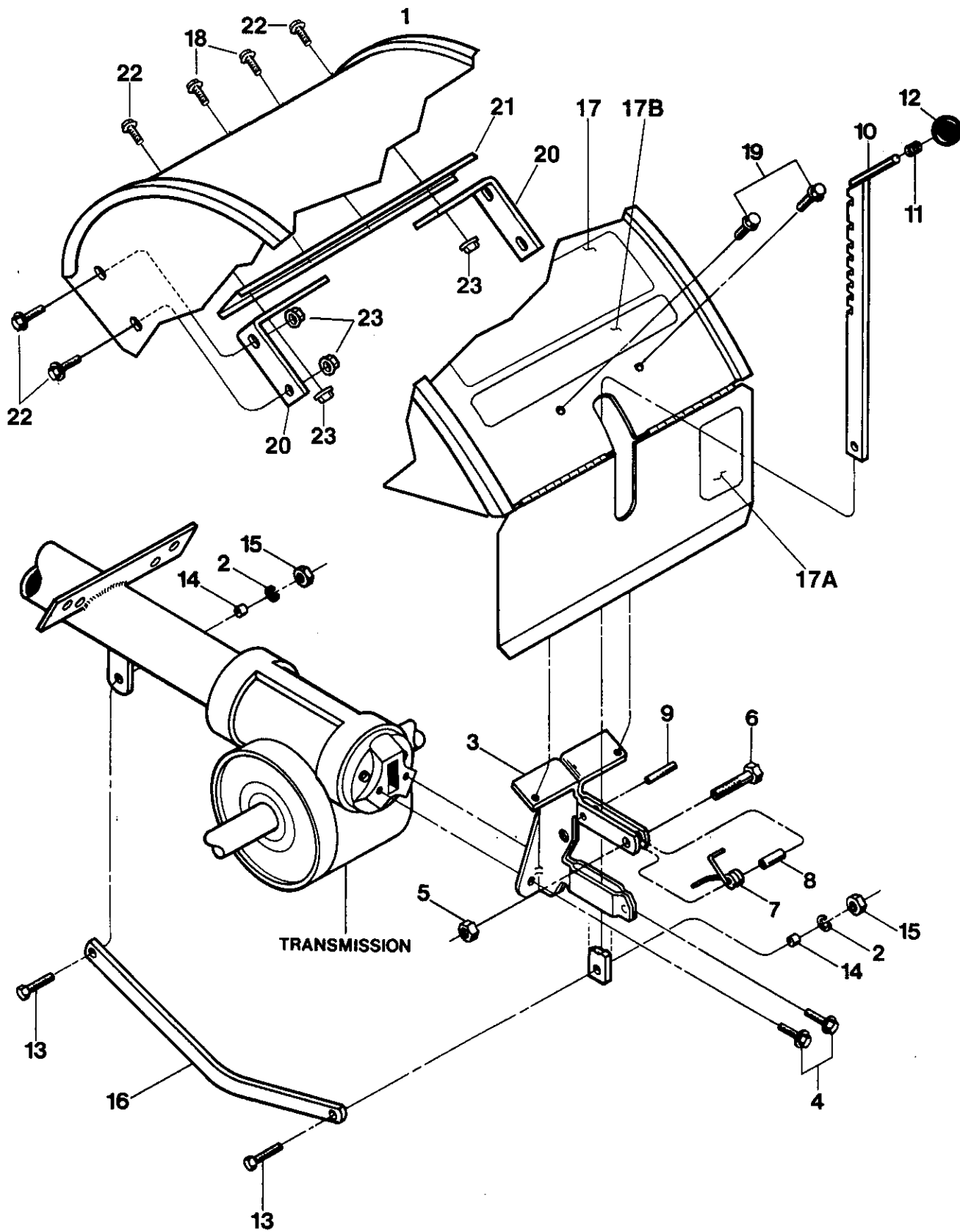

# CRAFTSMAN 8HP MODEL 987.293330 REPAIR PARTS

## HOOD, BRACKET & DEPTH REGULATOR

REF No.	PART No.	DESCRIPTION	QTY.	REF No.	PART No.	DESCRIPTION	QTY.
1	1916764	Hood-tine cover, with hinged flap (Incl. Ref. No. 17, 17A and 17B)	1	14	1113-1	Bushing-spacer, drag bar .....	2
2	1100243	Lockwasher-3/8.....	2	15	1186231	Nut-hex, 3/8-16 .....	2
3	1916184001	Bracket-hood & depth regulator ...	1	16	1916185001	Drag Bar-depth regulator .....	1
4	90038	Screw-flanged hex hd., 5/16-18 x 5/8* .....	2	17	1916805	Decal-tiller operating instructions	1
5	9811	Locknut-hex, 1/4-20.....	1	17A	1911361	Decal- Warning.....	1
6	1100069	Screw-hex hd., 1/4-20 x 1* .....	1	17B	1916807	Decal- Logo .....	1
7	9384	Spring-depth regulator plunger ....	1	18	9553	Screw-hex hd, self-tapping, 5/16-18 x 1/2* .....	2
8	9438	Spacer.....	1	19	9552	Screw-flanged hex hd, self-tapping, 1/4-20 x 1/2* .....	2
9	9308	Roll Pin-1/4 x 1 (spiral) .....	1	20	1916700001	Bracket- hood support.....	2
10	1916186001	Bar Assembly-depth adjustment ..	1	21	1916701001	Bracket- channel support .....	1
11	9120	Ring-retaining, tolerance ring.....	1	22	1186328	Bolt- hex hd., 5/16"-18 x 5/8" .....	6
12	9119	Knob-depth regulator (Incl. Ref. No. 11) .....	1	23	1186391	Nut- hex, 5/16"-18 .....	6
13	1100043	Screw-hex hd, 3/8-16 x 1-1/4*.....	2				

\* Specify GRADE 5 if ordering part locally.

# CRAFTSMAN 8HP MODEL 987.293330 REPAIR PARTS

ENGINE & SUPPORT BRACKETS, PULLEYS, BELTS, BELT COVER

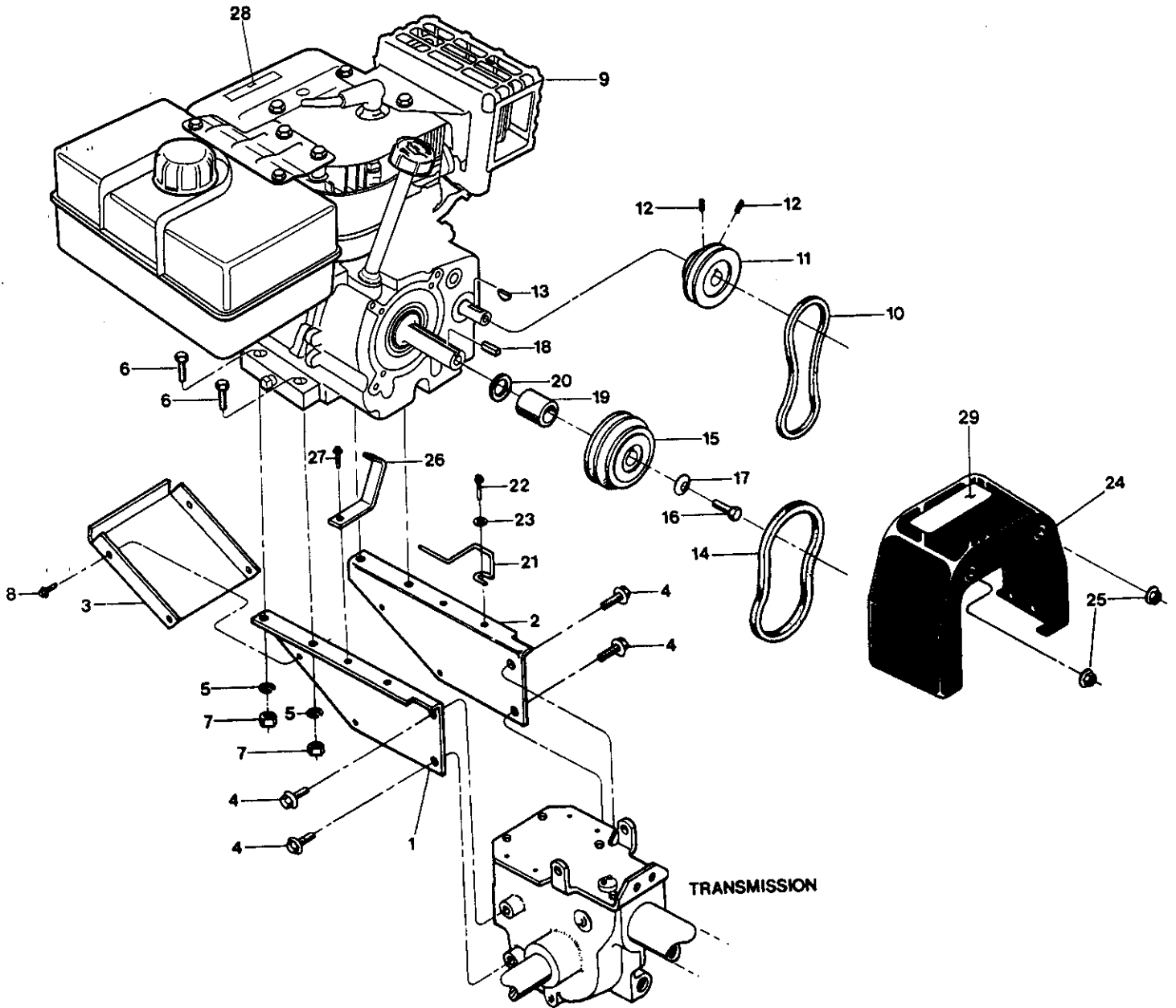



# CRAFTSMAN 8HP MODEL 987.293330 REPAIR PARTS

## ENGINE & SUPPORT BRACKETS, PULLEYS, BELTS, BELT COVER

REF No.	PART No.	DESCRIPTION	QTY.
1	1916604001	Support Bracket—engine, left side .	1
2	1916602001	Support Bracket—engine, right side.....	1
3	1916189001	Support Bracket (Pan)—engine, front.....	1
4	1186329	Screw—flanged hex hd., 5/16-18 x 3/4* .....	4
5	1100242	Lockwasher—5/16.....	4
6	1100799	Screw—hex hd., 5/16-18 x 1-1/2* ..	4
7	1186321	Nut—hex, 5/16-18.....	4
8	1900396	Screw—hex hd., 10-32 x 1/2, self-tapping .....	4
9	**	Engine .....	1
10	9022	Flat Belt—reverse drive.....	1
11	2477	Reverse Pulley—engine driven, for flat belt (Ref. No. 10).....	1
12	9561	Set Screw—Socket Head, 1/4-20 x 1/4* .....	2
13	9361	Key—Woodruff (size #5), reverse pulley to reverse PTO shaft.....	1

REF No.	PART No.	DESCRIPTION	QTY.
14	1909404	V-Belt—forward drive .....	1
15	20765	Forward Pulley—engine drive, for V-Belt (Ref. No. 14).....	1
16	1100004	Screw—hex hd., 5/16-24 x 3/4* .....	1
17	9944	Washer—disc spring (concave surface faces forward pulley) ....	1
18	9301	Key—3/16 sq. x 1, forward pulley to forward PTO shaft .....	1
19	97077	Spacer.....	1
20	1138-2	Shim .....	A/R
21	1916190001	Belt Guide—forward drive belt.....	1
22	9573	Screw—hex hd., self-tapping, 1/4-20 x 3/4* .....	1
23	9900	Washer—plain (flat), 1/4, S.A.E. ....	1
24	1904569	Cover—(incl. Ref. No.29) .....	1
25	1186391	Nut—5/16-18, locking, whiz-style ..	2
26	1916191001	Belt Guide—reverse drive belt .....	1
27	9552	Screw—flanged hex hd., self-tapping, 1/4-20 x 1/2* .....	1
28	1900766	Decal—Stabilization .....	1
29	1904557	Decal—Hot surfaces/belt warning ..	1
--	1771879	Craftsman Motor Oil, SAE 30 (Sears Ref. No. 33027).....	27 ozs.
--	1905219	Owner's Manual/Parts List.....	1

\* Specify GRADE 5 if ordering part locally.

\*\* Contact your local Sears Service Center for engine parts or service. Refer to engine nameplate for engine type and code information.

# CRAFTSMAN 8HP MODEL 987.293330 REPAIR PARTS

## TINES, WHEELS

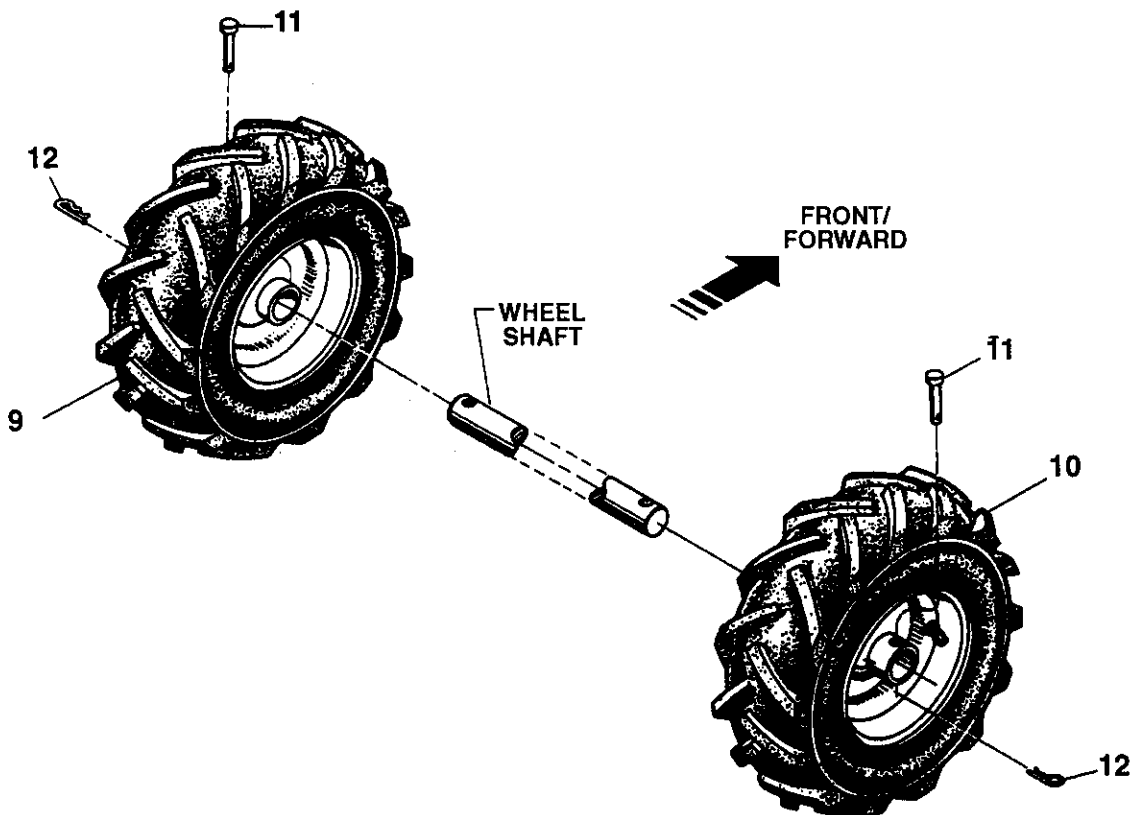
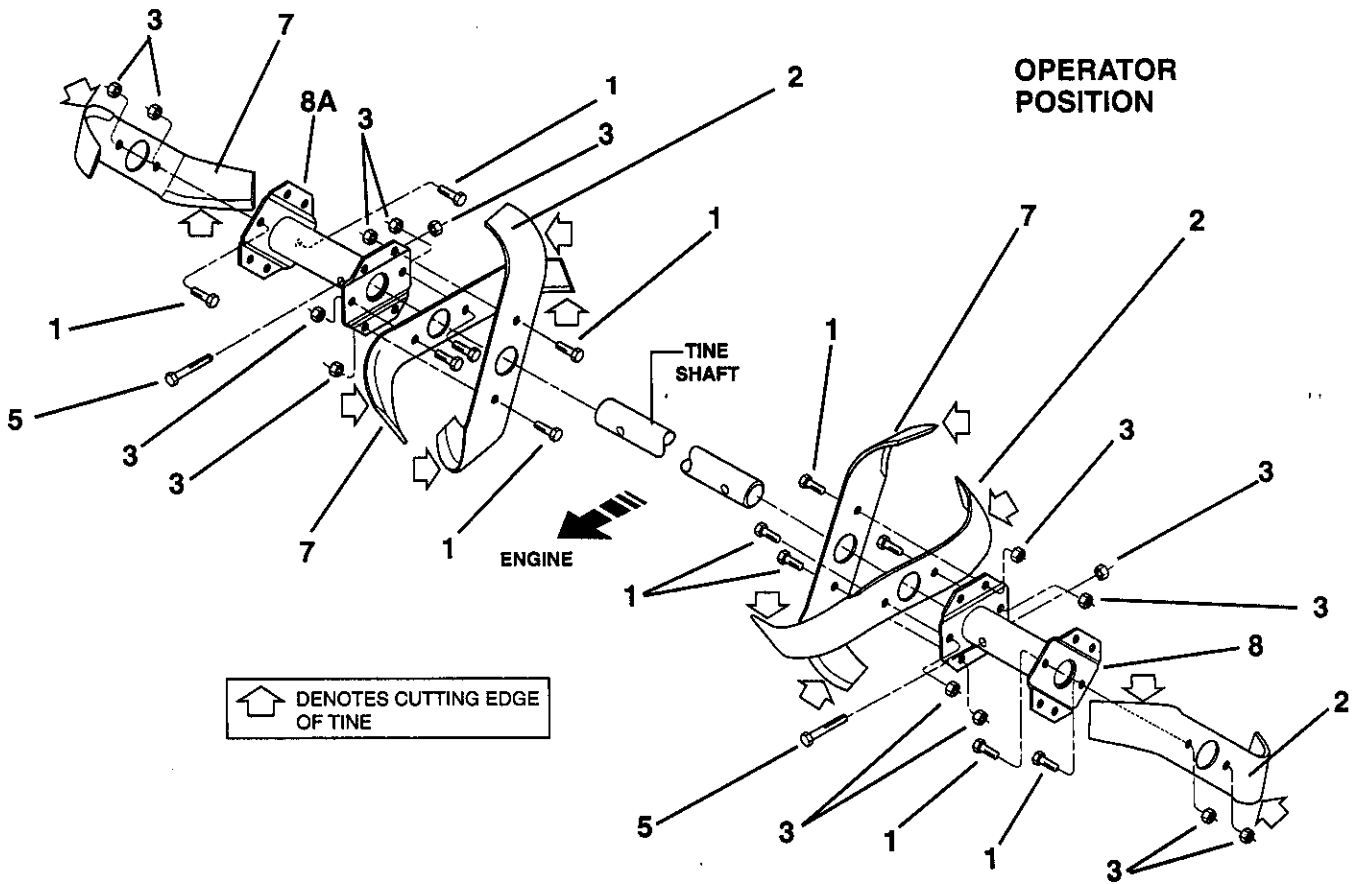

# CRAFTSMAN 8HP MODEL 987.293330 REPAIR PARTS

## TINES, WHEELS

REF No.	PART No.	DESCRIPTION	QTY.	REF No.	PART No.	DESCRIPTION	QTY.
1	1100068	Screw-hex hd., 3/8-16 x 3/4* .....	12	9	1915056	Wheel & Tire Assy-left side .....	1
2	1985100	Tine- twin-edged, right facing.....	3	10	1915057	Wheel & Tire Assy-right side.....	1
3	1733398	Hex Locknut, 3/8-16 .....	14	11	9380	Clevis Pin-.312 x 1-3/4 long.....	2
5	1982612	Screw-hex hd., 3/8-16 x 2, GRADE 8.....	2	12	9338	Hitch Pin .....	2
7	1985101	Tine- twin-edged, left facing.....	3				
8	1916693001	Tine Holder- left side .....	1				
8A	1916694001	Tine Holder- right side.....	1				

**IMPORTANT:** LEFT AND RIGHT SIDES OF TILLER ARE DETERMINED BY STANDING IN THE OPERATOR POSITION (BEHIND THE HOOD) AND FACING THE DIRECTION OF FORWARD TRAVEL.

MOUNT TINES SO THE CUTTING EDGE AT THE  
TOP OF EACH TINE FACES THE OPERATOR

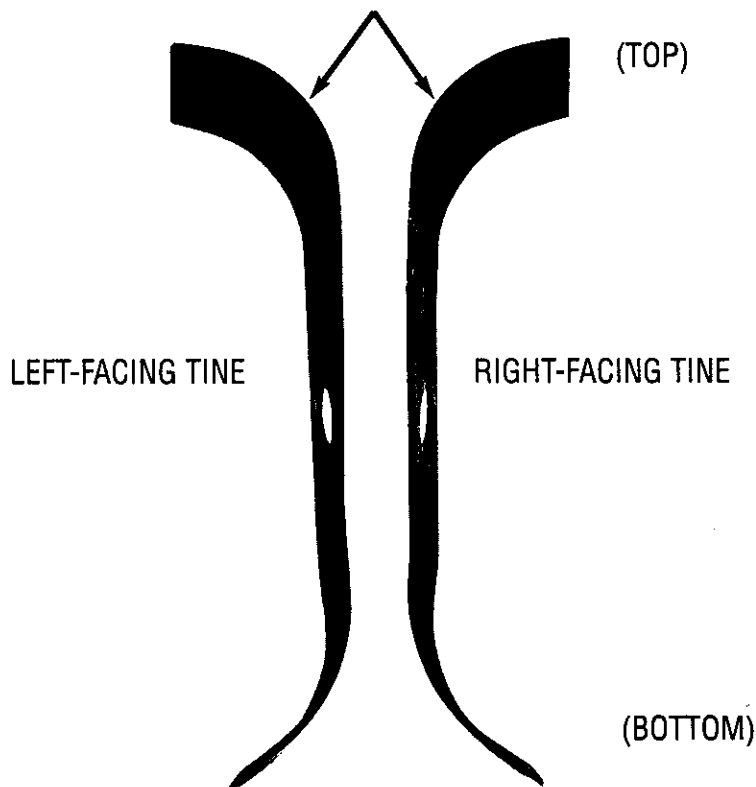

# CRAFTSMAN 8HP MODEL 987.293330 REPAIR PARTS

## TRANSMISSION HOUSING, COVERS, SEALS, GASKETS & PLUGS

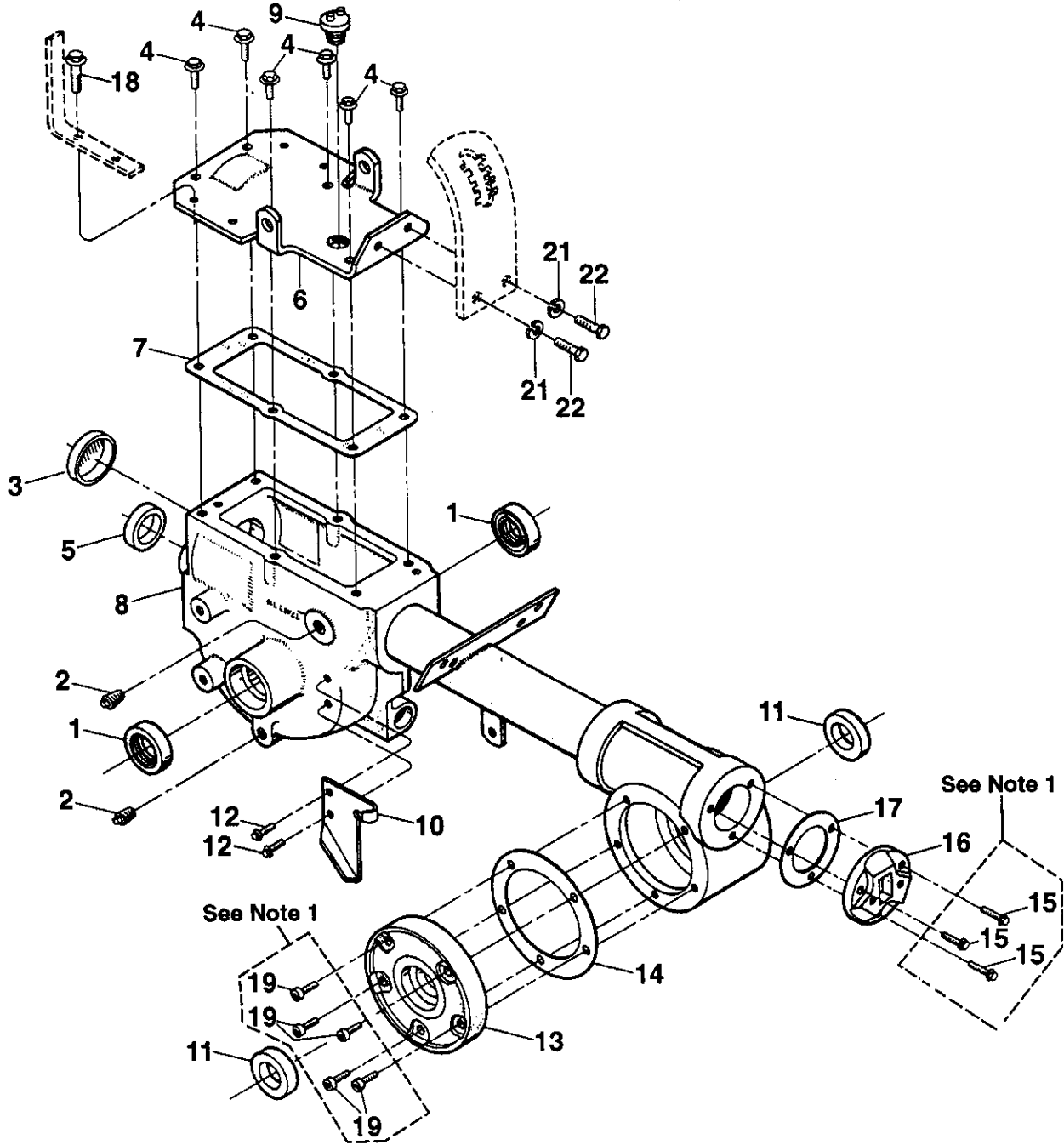

# CRAFTSMAN 8HP MODEL 987.293330 REPAIR PARTS

## TRANSMISSION HOUSING, COVERS, SEALS, GASKETS & PLUGS

REF No.	PART No.	DESCRIPTION	QTY.
1	9621	Oil Seal—double lip, wheel shaft, right and left sides.....	2
2	9726	Plug—pipe, 1/4, oil level hole and gear oil drain hole.....	2
3	97076	Seal—transmission bore.....	1
4	1186329	Screw—flanged hex hd., 5/16-18 x 3/4*.....	6
5	85030	Oil Seal—input pinion shaft.....	1
6	1916193001	Cover—top of transmission.....	1
7	20694	Gasket—transmission top cover.....	1
8	20893	Transmission case, tube and rear housing assembly.....	1
9	9467	Plug—gear oil fill hole.....	1
10	1916198001	Plate—wheel drive cable mounting.	1
11	97073	Oil Seal—tiller shaft, left and right sides.....	2
12	90038	Screw—flanged hex hd., 5/16-18 x 5/8*.....	2
13	1916199001	Cover—tiller housing, left side.....	1
14	1129-1	Gasket—tiller housing cover, .010 (fits all covers).....	As Req'd

REF No.	PART No.	DESCRIPTION	QTY.
15	1915089	Screw Kit: includes three (3) 1/4-20 x 7/8" self-sealing screws.....	As Req'd
16	1900881001	Cap—rear bearing.....	1
17	1124-2	Gasket—rear bearing cap, .010 thick.....	As Req'd
18	1186331	Screw—flanged hex hd., 5/16-18 x 1".....	4
19	1915087	Screw Kit: includes five (5) 1/4"-20 x 5/8" self-sealing screws.....	As Req'd
20	-----	This Ref. No. not used	
21	1100243	Lockwasher—3/8.....	2
22	1100068	Screw—hex hd., 3/8-16 x 3/4*.....	2

\* Specify GRADE 5 if ordering part locally.

# CRAFTSMAN 8HP MODEL 987.293330 REPAIR PARTS

## DRIVE SHAFT

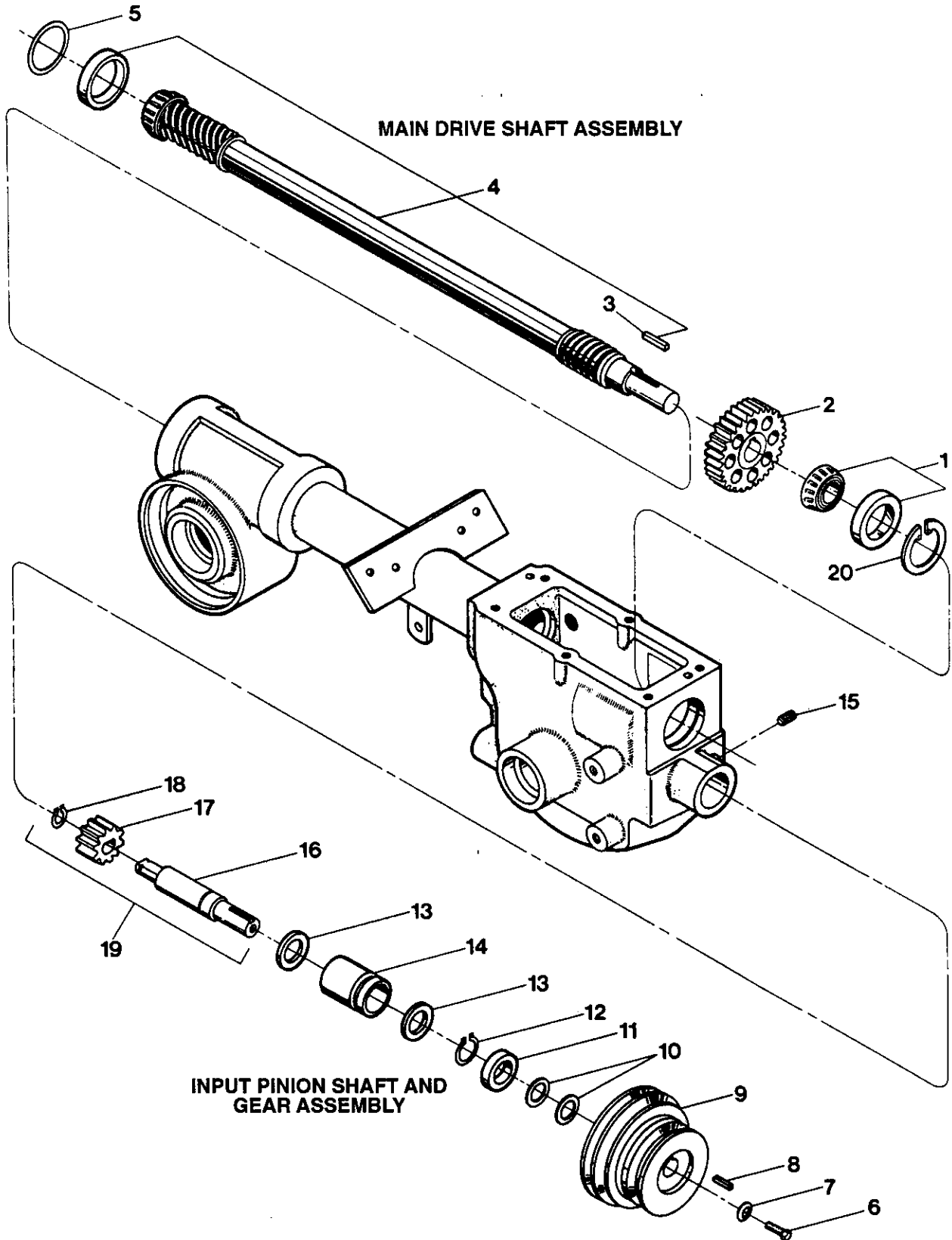

# CRAFTSMAN 8HP MODEL 987.293330 REPAIR PARTS

## DRIVE SHAFT

REF No.	PART No.	DESCRIPTION	QTY.	REF No.	PART No.	DESCRIPTION	QTY.
1	1714	Bearing-tapered roller with race..	1	5	1224-2	Shim-same as above, but .030 thick (see Note 1) .....	As Req'd
2	20718	Gear-spur, main drive shaft.....	1	5	1224-3	Shim-same as above, but .005 thick (see Note 1) .....	As Req'd
3	9301	Key-3/16 sq. x 1.....	1	...	1325C	Shim Set-includes the following shims: two 1224-1; two 1224-2; one #1224-3 .....	As Req'd
4	1916765	Drive Shaft-main drive shaft is one-piece with integral, single-lead work-hardened worm at front to drive the wheel worm gear, and integral six-lead work-hardened worm at rear to drive the tiller gear (also includes pressed-on #1714 rear roller bearing, race for bearing and #9301 key) .....	1				
5	1224-1	Shim-rear bearing cap, .010 thick (see Note 1 below) .....	As Req'd				

NOTE 1-Shim between drive shaft rear bearing and rear bearing cap to achieve 5-to-10 thousandths of an inch (.005-.010) end play on drive shaft

## INPUT PINION SHAFT & GEAR ASSEMBLIES

REF No.	PART No.	DESCRIPTION	QTY.	REF No.	PART No.	DESCRIPTION	QTY.
6	1100004	Screw-hex hd., 5/16-24 x 3/4* ...	1	16	20791	Input Pinion-steel shaft.....	1
7	9944	Washer-disc spring (concave surface faces pulley) .....	1	17	20792	Gear-input pinion .....	1
8	9301	Key-3/16 sq. x 1.....	1	18	9093	Retainer-snap ring, external.....	1
9	20507	Pulley-transmission drive .....	1	19	20799	Pinion Assy-(incl. one each of Ref. No.'s 16, 17 and 18) .....	As Req'd
10	1440	Washer-support .....	2	20	9517	Retainer-snap ring, internal .....	1
11	85030	Oil Seal-input pinion shaft, front.	1	21	94018	Washer-sheave shoulder .....	1
12	9500	Ring-retaining (snap ring), external	1				
13	9953	Washer-thrust.....	2				
14	9428	Bushing .....	1				
15	9677	Set Screw-5/16-18 x 3/8* .....	1				

\* Specify GRADE 5 if ordering part locally.

# CRAFTSMAN 8HP MODEL 987.293330 REPAIR PARTS

## WHEEL SHAFT, ECCENTRIC SHAFT & TILLER SHAFT ASSEMBLIES

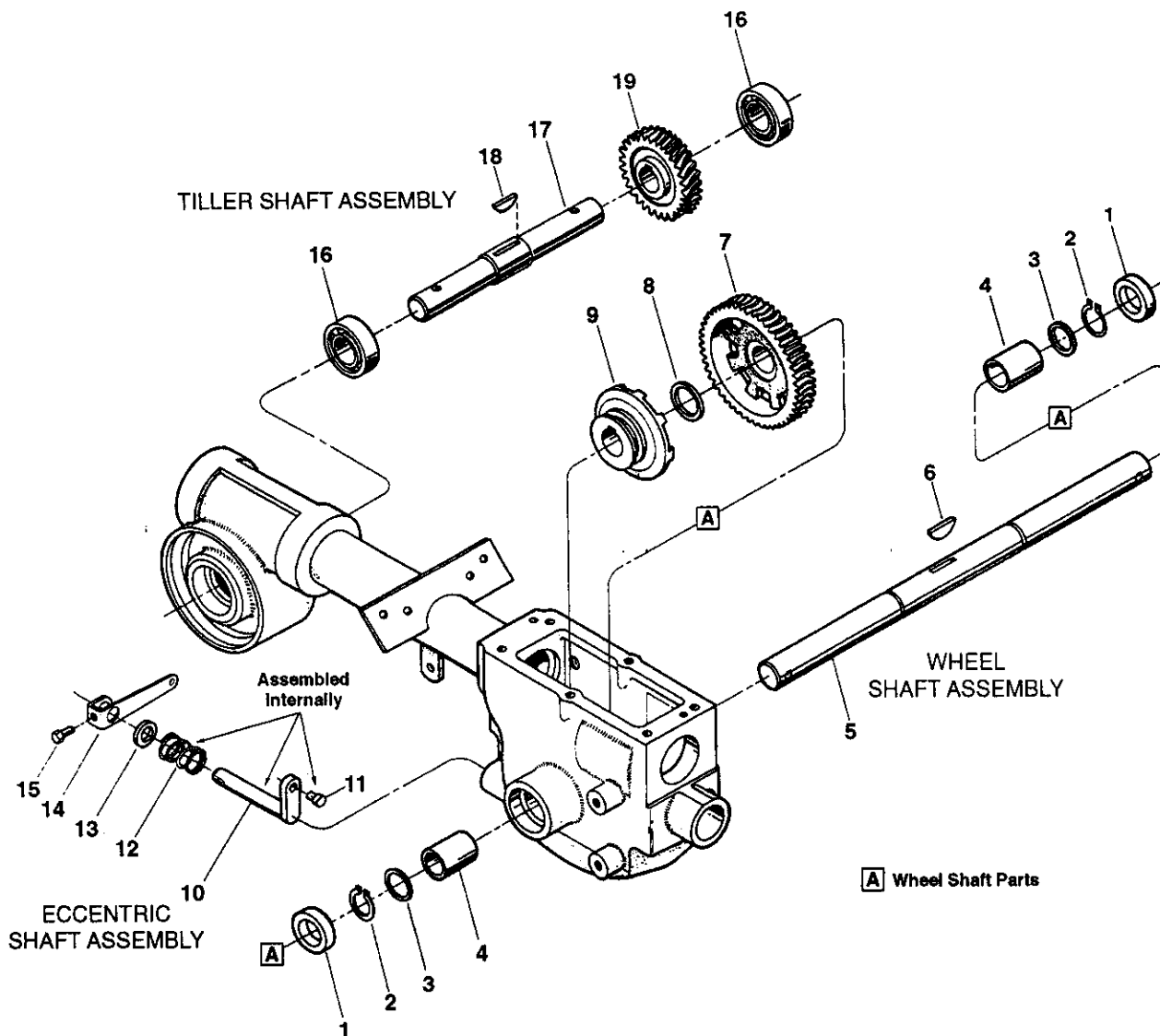

REF No.	PART No.	DESCRIPTION	QTY.
1	9621	Oil Seal—left and right sides .....	2
2	9511	Ring—retaining, heavy-duty, external	2
3	1166-1	Shim—1-1/64 I.D., .062 thick .....	As Req'd
---	1166-2	Shim—as above, but .030 thick ....	As Req'd
---	1166-3	Shim—as above, but .015 thick ....	As Req'd
---	1166-4	Shim—as above, but .010 thick ....	As Req'd
4	1086	Bushing .....	2
5	1916711	Wheel Shaft (axle) .....	1
6	9373	Key—hi-pro (1/4 x 1-5/16), clutch to wheel shaft.....	1
7	20914	Gear—wheel drive (worm gear), cast iron .....	1

REF No.	PART No.	DESCRIPTION	QTY.
8	9935	Shim—between key and gear (1.016 I.D. x 1.468 O.D. x .062 thick).....	1
9	20712	Clutch—wheel drive, cast iron.....	1
10	20879	Eccentric Shaft—wheel clutch shifting .....	1
11	1442	Pin—eccentric shaft.....	1
12	9055	Spring .....	1
13	9622	Oil Seal—eccentric shaft .....	1
14	20757	Lever—eccentric shaft .....	1
15	11000804	Screw—hex hd., 1/4-20 x 1/2* .....	1
16	97074	Ball Bearing—for tiller shaft .....	2
17	1916709	Tiller Shaft .....	1
18	1104	Key—woodruff, 1/4 x 1-1/4, for tiller shaft/worm gear .....	1
19	1904279	Worm Gear—bronze, tiller drive....	1

\* Specify GRADE 5 if ordering part locally.



# CRAFTSMAN 8HP MODEL 987.293330 REPAIR PARTS

## BUMPER ASSEMBLY

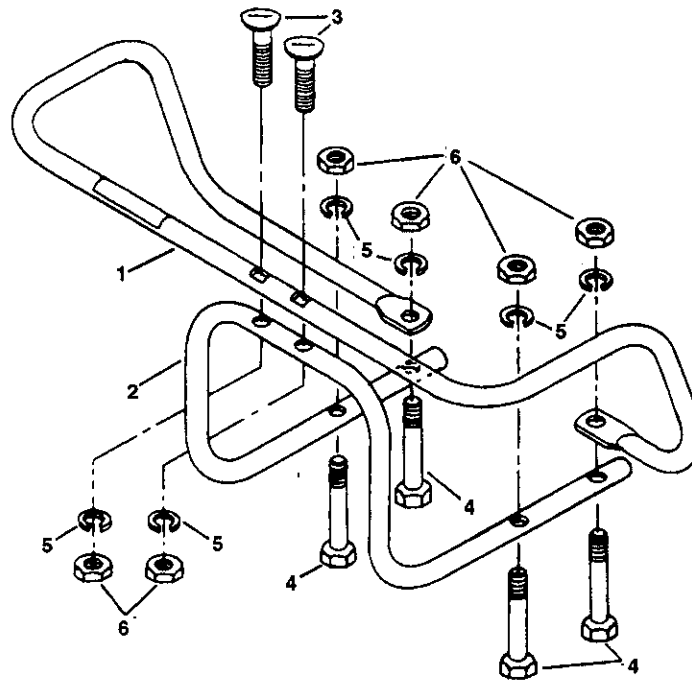

REF No.	PART No.	DESCRIPTION	QTY.
<b>Bumper Assembly</b>			
1	1916714001	Bumper-top section .....	1
2	1904758001	Bumper-bottom section .....	1
3	1731025	Bolt-curved head, 5/16-18 x 2 (special bolt); also see #1915811 hardware kit .....	2
4	1111608	Bolt-hex hd., 5/16-18 x 2-1/2*, not avail. separately (order #1915811 hardware kit .....	4
5	1100242	Lockwasher-5/16, not avail. separately (order #1915811 hardware kit .....	6
6	1186230	Nut-hex, 5/16-18, not avail. .... separately (order #1915811 hardware kit .....	6
---	1915811	Hardware Kit: two #1731025 curved head bolts; four #1111608 hex hd. bolts; six #1100242 lock- washers; six #1186230 hex nuts	1



# CRAFTSMAN 8HP MODEL 987.293330 REPAIR PARTS

Craftsman 4-Cycle, 8HP Engine (143.998001)

## Engine Assembly

Ref #	Part #	Description	Qty	Ref #	Part #	Description	Qty	Ref #	Part #	Description	Qty
1	35385	Cylinder (Incl. 2,20,72)	1	92	650880	Lockwasher	1	224	27915A	Intake Pipe Gasket	1
2	27652	Dowel Pin	2	93	650881	Flywheel Nut	1	238	28820	Screw, #10-32 x 1/2"	2
15	30699C	Governor Rod (Incl. 15A, 15B)	1	100	35135	Solid State Ignition	1	239	27272A	Air Cleaner Gasket	1
15A	30700	Governor Yoke	1	101	610118	Spark Plug Cover	1	240	33266	Air Cleaner Body	1
15B	650494	Screw, #6-40 x 5/16"	1	102	651024	Solid State Mounting Stud	2	242	33267	Air Cleaner Bracket	1
16	33454	Governor Lever	1	103	651007	Screw, Torx T-15, #10-24 x 15/16"	2	245	33268	Air Cleaner Filter	1
17	29916	Governor Lever Clamp	1	110	35187	Ground Wire	1	245A	35881	Air Cleaner Filter	1
18	651028	Screw, Torx T-15, #8-32 x 3/8"	1	119	36448	Cylinder Head Gasket	1	250	33269A	Air Cleaner Cover	1
19	34663	Extension Spring	1	120	36449	Cylinder Head	1	251	650513	Wing Nut, 1/4-20	1
20	35319	Oil Seal	1	125	27878A	Exhaust Valve (Std.) (Incl. 151)	1	260	33375D	Blower Housing	1
25	36460	Blower Housing Baffle	1	125	27880A	Exhaust Valve (1/32" OS) (Incl. 151)	1	261	650788	Screw, 5/16-18 x 3/4"	2
26	650561	Screw, 1/4"-20 x 5/8"	2	126	34035	Intake Valve (Std.) (Incl. 151)	1	262	29747B	Screw, Torx T-40 5/16-24 x 21/32"	2
28	30322	Lock Nut, #8-32	1	126	34036	Intake Valve (1/32" OS) (Incl. 151)	1	264A	650802	Screw, 1/4-20 x 5/8"	1
30	36245	Crankshaft	1	127	650691	Washer	9	265	33272B	Cylinder Head Cover	1
35	29826	Screw, #10-32 x 3/4"	1	128	650590	Belleville Washer	7	275	34185B	Muffler	1
36	29918	Lockwasher	1	130	650694A	Screw, 5/16"-18 x 2"	7	276	31588	Locking Plate	1
37	29216	Locknut, #10-32	1	130A	650727	Screw, 5/16"-18 x 1-3/4"	2	277	650729	Screw, 5/16-18 x 3-3/16"	1
38	29642	Retaining Ring	1	130B	651055	Screw, 5/16"-18 x 5/8"	2	277A	651036	Screw, 5/16-18 x 3-31/32"	1
40	40011	Piston, Pin & Ring Set (Std.)	1	135	33636	Resistor Spark Plug (RJ17LM)	1	278	36908	Spacer	1
40	40012	Piston, Pin & Ring Set (.010" OS)	1	139	33369	Governor Gear Bracket	1	280	36799A	Heat Shield	1
41	40009	Piston & Pin Assy. (Std.), (Incl. 43)	1	140	650836	Screw, #10-24 x 1/2"	2	281	33013	Starter Bubble Cover	1
41	40010	Piston & Pin Assy. (.010" OS), (Incl. 43)	1	149	27882	Valve Spring Cap	1	282	650760	Screw, #8-32 x 3/8"	1
42	40013	Ring Set (Std.)	1	149A	35862	Valve Spring Cap	1	285	35985B	Starter Cup	1
42	40014	Ring Set (.010" OS)	1	150	27881	Valve Spring	2	287	29752	Nut & Lockwasher, 1/4-28	4
43	27888	Piston Pin Retaining Ring	1	151	32581	Valve Spring Keeper	2	290	30705	Fuel Line	1
45	36897	Connecting Rod Assy. (Incl. 47, 49)	1	169	27896A	Breather Gasket	2	292	26460	Fuel Line Clamp	2
47	651033	Connecting Rod Bolt	2	170	28423	Breather Body	1	298	650665	Screw, 1/4-15 x 3/4"	2
48	34034	Valve Lifter	2	171	28424	Breather Element	1	300	34186A	Fuel Tank (Incl. 292,301)	1
49	36896	Oil Dipper	1	172	28425	Valve Cover	1	301	36246	Fuel Cap	1
50	35444	Camshaft (MCR)	1	173	35350	Breather Tube	1	305	35554	Oil Fill Tube	1
60	33273A	Blower Housing Extension	1	174	650128	Screw, #10-24 x 1/2"	2	307	35499	"O" Ring	1
65	650128	Screw, #10-24 x 1/2"	1	178	29752	Nut & Lockwasher, 1/4-28	2	308	35540	Fill Tube Clip	1
69	35262A	Cylinder Cover Gasket	1	182	30088A	Screw, 1/4-28 x 1"	2	310	36593	Dipstick	1
70	35445A	Cylinder Cover (Incl. 71, 75, 76, 80)	1	184	33263	Carburetor to Intake Pipe Gasket	1	325	29443	Wire Clip	1
71	35377	Crankshaft Bushing	1	185	34707	Intake Pipe	1	340	34154	Fuel Tank Bracket	1
72	27642	Oil Drain Plug	2	186	34661	Governor Link	1	341	34155	Fuel Tank Bracket	1
75	35319	Oil Seal	1	200	34664	Control Bracket (Incl. 19, 203, 204, 206)	1	342	650561	Screw, 1/4-20 x 5/8"	1
76	28926	Oil Seal	1	203	31342	Compression Spring	1	370G	35274	Oil Instruction Decal	1
80	31845	Governor Shaft	1	204	651029	Screw, Torx T-10, 5-40 x 7/16"	1	370K	36695	Starter Decal	1
81	30590A	Washer	1	206	610973	Terminal	1	380	640152	Carburetor (Incl. 184)	1
82	35378	Governor Gear Assy. (Incl. 81)	1	207	33878	Throttle Link	1	390	590746	Rewind Starter	1
83	30588A	Governor Spool	1	209	650821	Screw, #10-32 x 1/2"	2	(Note: This engine could have been built with the 590704 Rewind Starter.)			
84	29193	Retaining Ring	1	210	27793	Conduit Clip	1	400	36450B	Gasket Set (Incl. 27272A (1), 27896A (2), 27915A (1), 29673 (1), 33263 (1), 33629 (1), 34698A (1), 35262A (1), 36448 (1))	1
86	650833	Screw, 1/4-20 x 1-3/16"	7	211	28942	Screw, #10-32 x 3/8"	1	416	34479A	Spark Arrestor Kit (Opt.)	1
87	650832	Screw, 1/4-20 x 1-11/16"	1	223	650378	Screw, Torx T-30 5/16-18 x 1-1/8"	2	900	----	Replacement Short Block 756318, order	1
89	32589	Flywheel Key	1								
90	611090	Flywheel	1								

# CRAFTSMAN 8HP MODEL 987.293330 REPAIR PARTS

Carburetor No. 640152- Craftsman 4-Cycle, 8HP Engine (143.998001)

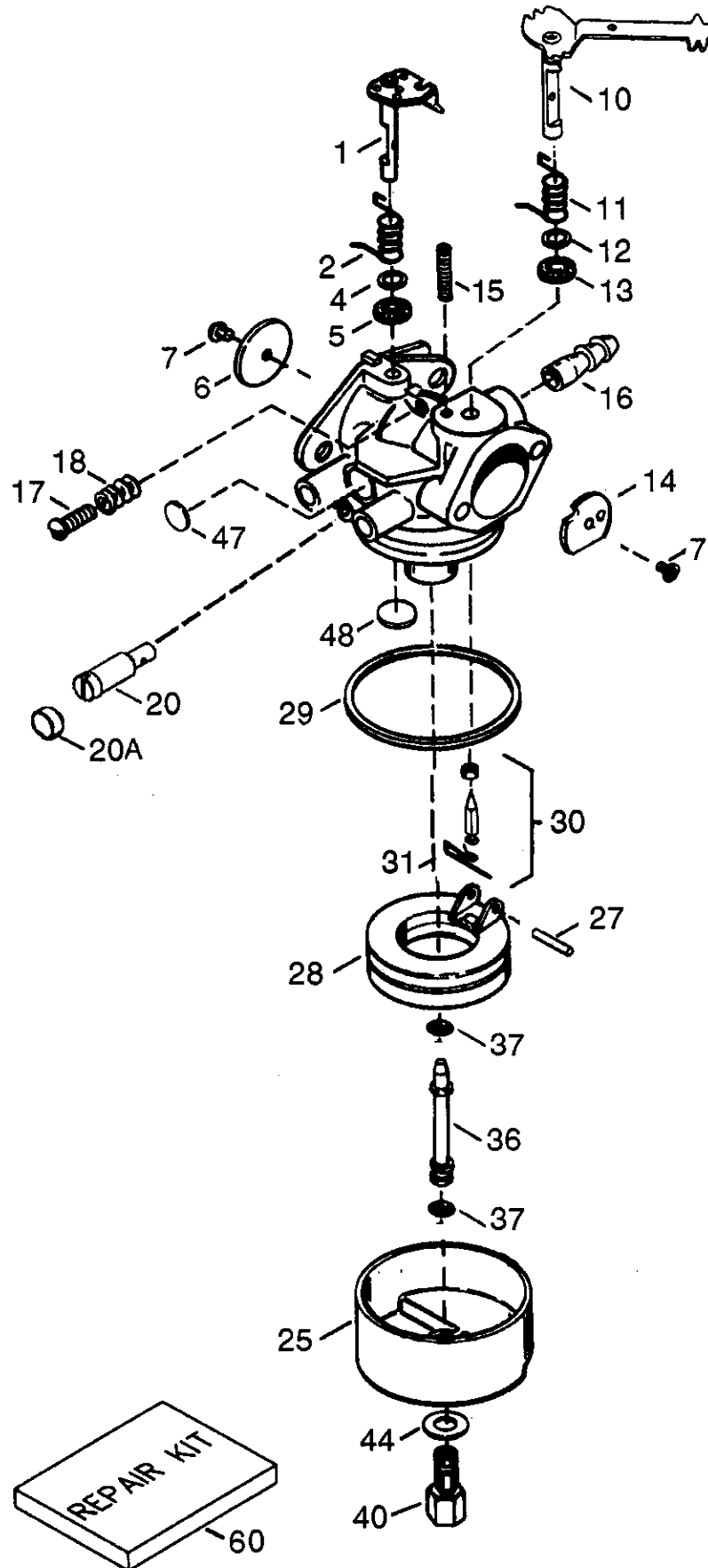

# CRAFTSMAN 8HP MODEL 987.293330 REPAIR PARTS

Carburetor No. 640152— Craftsman 4-Cycle, 8HP Engine (143.998001)

Ref #	Part #	Description	Qty	Ref #	Part #	Description	Qty	Ref #	Part #	Description	Qty
0	640152	Carburetor (Incl. 184 from Engine Parts List) .....	1	14	631753	Choke Shutter .....	1	30	631021	Inlet Needle, Seat & Clip (Incl. 31) .....	1
1	631776A	Throttle Shaft/Lever Assy... ..	1	15	630735	Choke Positioning Spring ..	1	31	631022	Spring Clip .....	1
2	631970	Throttle Return Spring .....	1	16	632164	Fuel Fitting .....	1	36	640113	Main Nozzle Tube .....	1
4	631184	Dust Seal Washer .....	1	17	651025	Throttle Crack Screw/ Idle Speed Screw .....	1	37	632547	Main Nozzle Tube "O" Ring	2
5	631183	Dust Seal (Throttle) .....	1	18	630766	Tension Spring .....	1	40	640114	High Speed Bowl Nut .....	1
6	640109	Throttle Shutter .....	1	20	640027	Idle Restrictor Screw .....	1	44	27110A	Bowl Nut Washer .....	1
7	650506	Shutter Screw .....	2	20A	640053	Idle Restrictor Screw Cap ..	1	47	630748	Welch Plug, Idle Mixture ..	1
10	632740	Choke Shaft & Lever Assy. ..	1	25	631867	Float Bowl .....	1	48	631027	Welch Plug, Atmospheric Vent .....	1
11	632043	Choke Return Spring .....	1	27	631024	Float Shaft .....	1	60	632760	Repair Kit .....	1
12	631184	Dust Seal Washer .....	1	28	632019	Float .....	1				
13	631183	Dust Seal (Choke).....	1	29	631028	Float Bowl "O" Ring .....	1				

# CRAFTSMAN 8HP MODEL 987.293330 REPAIR PARTS

**Starter No. 590746**  
Craftsman 4-Cycle, 8HP Engine (143.998001)

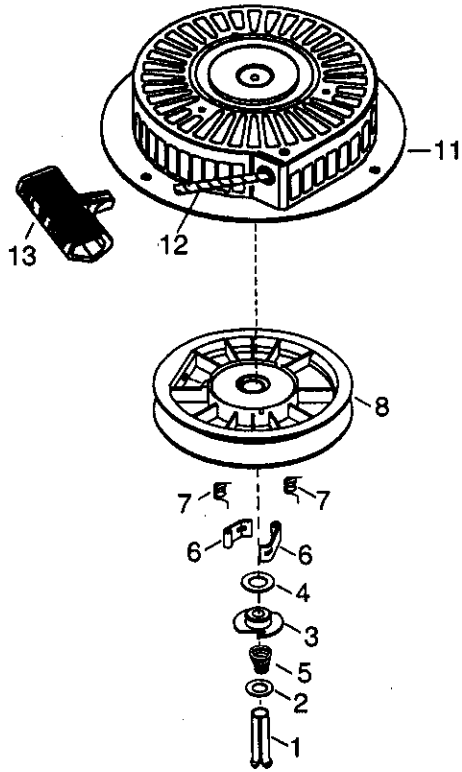

**Starter No. 590704**  
Craftsman 4-Cycle, 8HP Engine (143.998001)

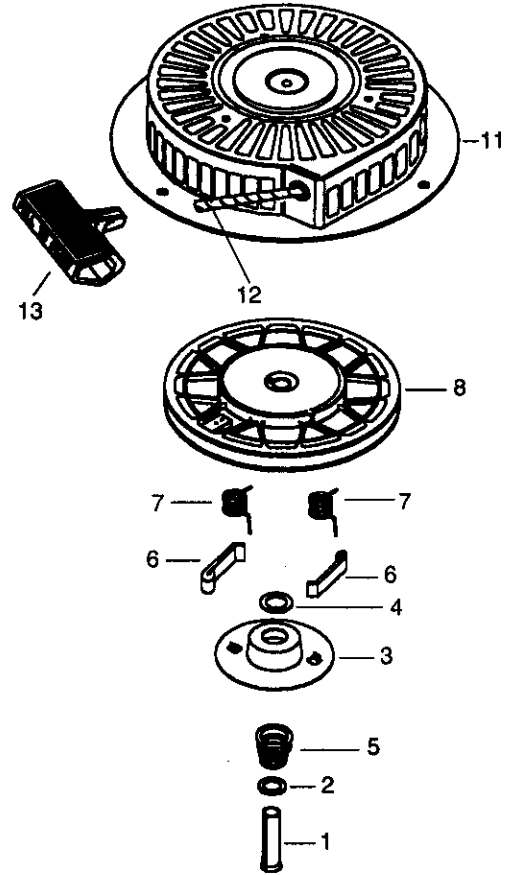

# CRAFTSMAN 8HP MODEL 987.293330 REPAIR PARTS

## Starter No. 590746 —Craftsman 4-Cycle, 8HP Engine (143.998001)

Ref #	Part #	Description	Qty
0	590746	Recoil Starter .....	1
1	590599A	Spring Pin (Incl. 4) .....	1
2	590600	Washer .....	1
3	590679	Retainer .....	1
4	590601	Washer .....	1
5	590678	Brake Spring .....	1
6	590680	Starter Dog .....	2
7	590412	Dog Spring .....	2
8	590681	Pulley & Rewind Spring Assy.....	1
11	590747	Starter Housing Assy.....	1
12	590535	Starter Rope (98" x 9/64")..	1
13	590701	Starter Handle.....	1

## Starter No. 590704 —Craftsman 4-Cycle, 8HP Engine (143.998001)

0	590704	Recoil Starter .....	1
1	590599A	Spring Pin (Incl. 14) .....	1
2	590600	Washer .....	1
3	590696	Retainer .....	1
4	590601	Washer .....	1
5	590697	Brake Spring .....	1
6	590698	Starter Dog .....	2
7	590699	Dog Spring .....	2
8	590700	Pulley & Rewind Spring Assy.....	1
11	590705	Starter Housing Assy.....	1
12	590535	Starter Rope (98" x 9/64")..	1
13	590701	Starter Handle.....	1

**For in-home major brand repair service:**

Call 24 hours a day, 7 days a week

**1-800-4-MY-HOME<sup>SM</sup>** (1-800-469-4663)

**Para pedir servicio de reparación a domicilio – 1-800-676-5811**

In Canada for all your service and parts needs call – **1-800-665-4455**  
Au Canada pour tout le service ou les pièces

**For the repair or replacement parts you need:**

Call 6 am – 11 pm CST, 7 days a week

**PartsDirect<sup>SM</sup>**

**1-800-366-PART** (1-800-366-7278)

**Para ordenar piezas con entrega a domicilio – 1-800-659-7084**

**For the location of a Sears Parts and Repair Center in your area:**

Call 24 hours a day, 7 days a week

**1-800-488-1222**

**For information on purchasing a Sears Maintenance Agreement  
or to inquire about an existing Agreement:**

Call 9 am – 5 pm, Monday – Saturday

**1-800-827-6655**

