

MULTIPLE COMPACT DISC PLAYER

CD-223M/DPF-J3010

CD-224M/DPF-J5010

SERVICE MANUAL

KENWOOD

© 1998-2/B51-5409-00 (K/K) 3430

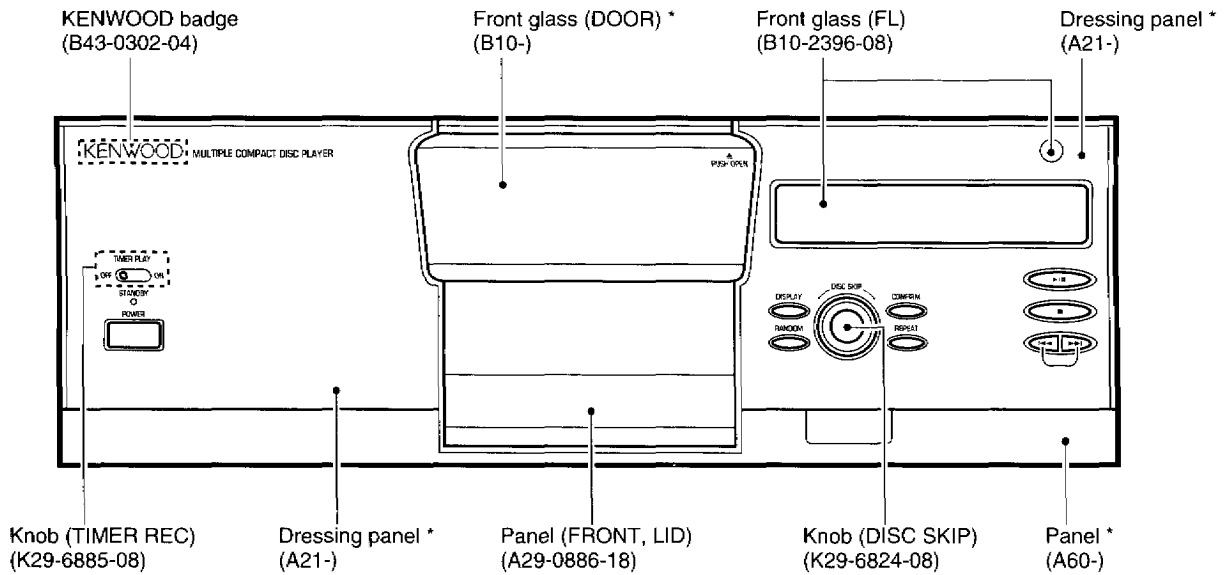
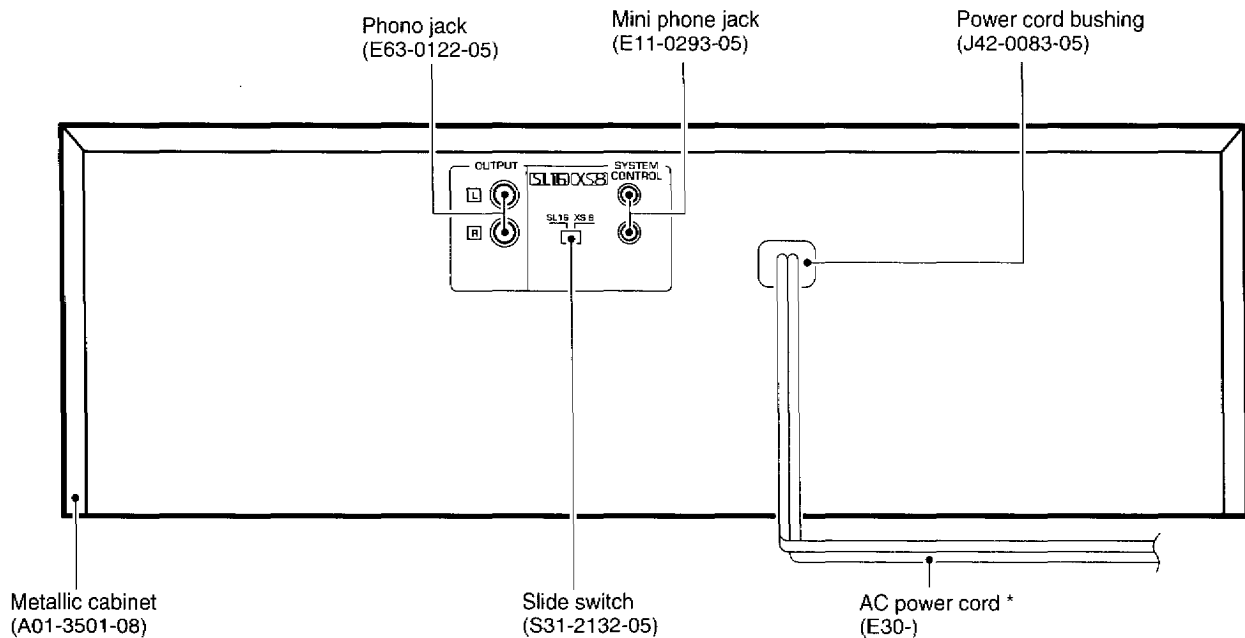

Illustration is CD-224M/DPF-J5010.



* Refer to parts list on page 19.

CD-223M/224M/DPF-J3010/J5010

CONTENTS/ACCESSORIES/EXTERNAL VIEW

Contents

CONTENTS/ACCESSORIES/EXTERNAL VIEW	2	PC BOARD	11
MECHANISM OPERATION DESCRIPTION	3	SCHEMATIC DIAGRAM	13
DISASSEMBLY FOR REPAIR	4	EXPLODED VIEW	17
CIRCUIT DESCRIPTION	5	PARTS LIST	19
ADJUSTMENT	10	SPECIFICATIONS	Back cover

Accessories

Audio cord (1)
(E30-0505-05)

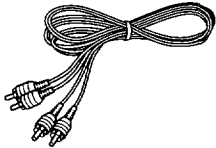

System control cord (1)
(E30-2816-05)

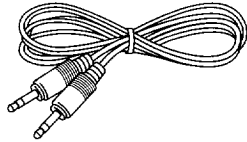

Batteries (R6/AA) (2)

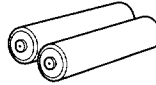

AC Plug adaptor (1)
(E03-0115-05) M type only

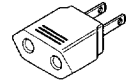

Remote control unit (1)
(A70-1175-08) : CD-224M/DPF-J5010

Battery cover : (A09-0374-08)

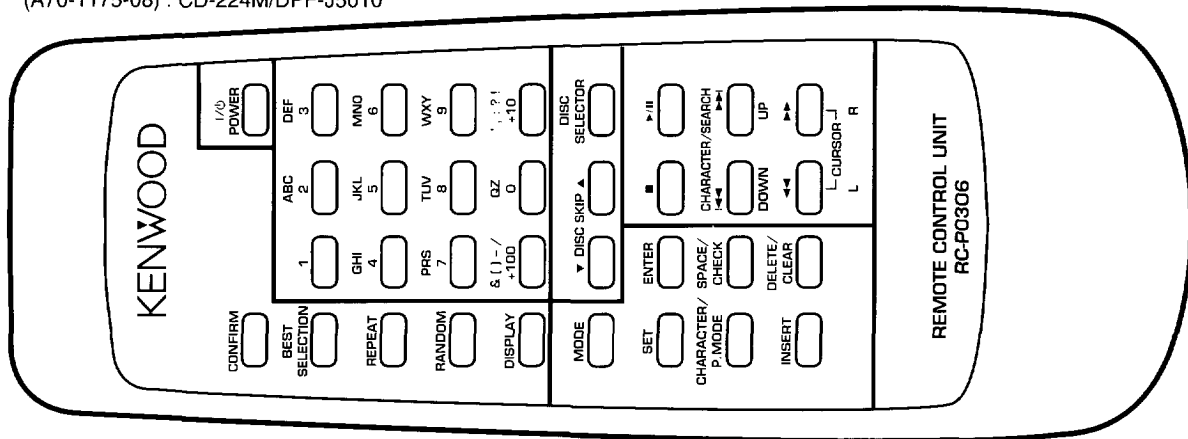

External view

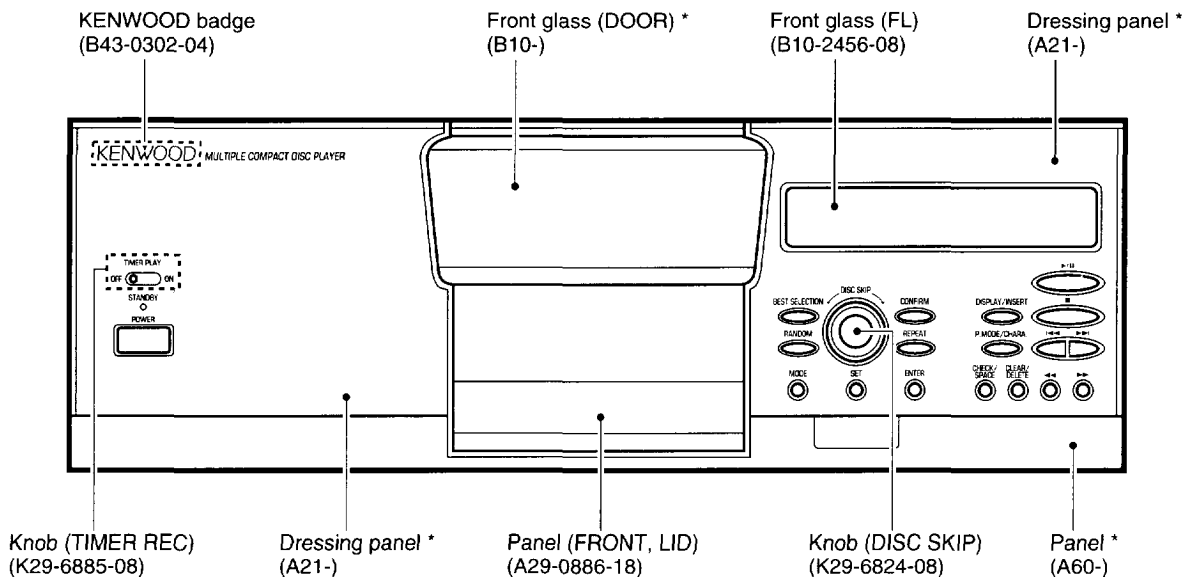
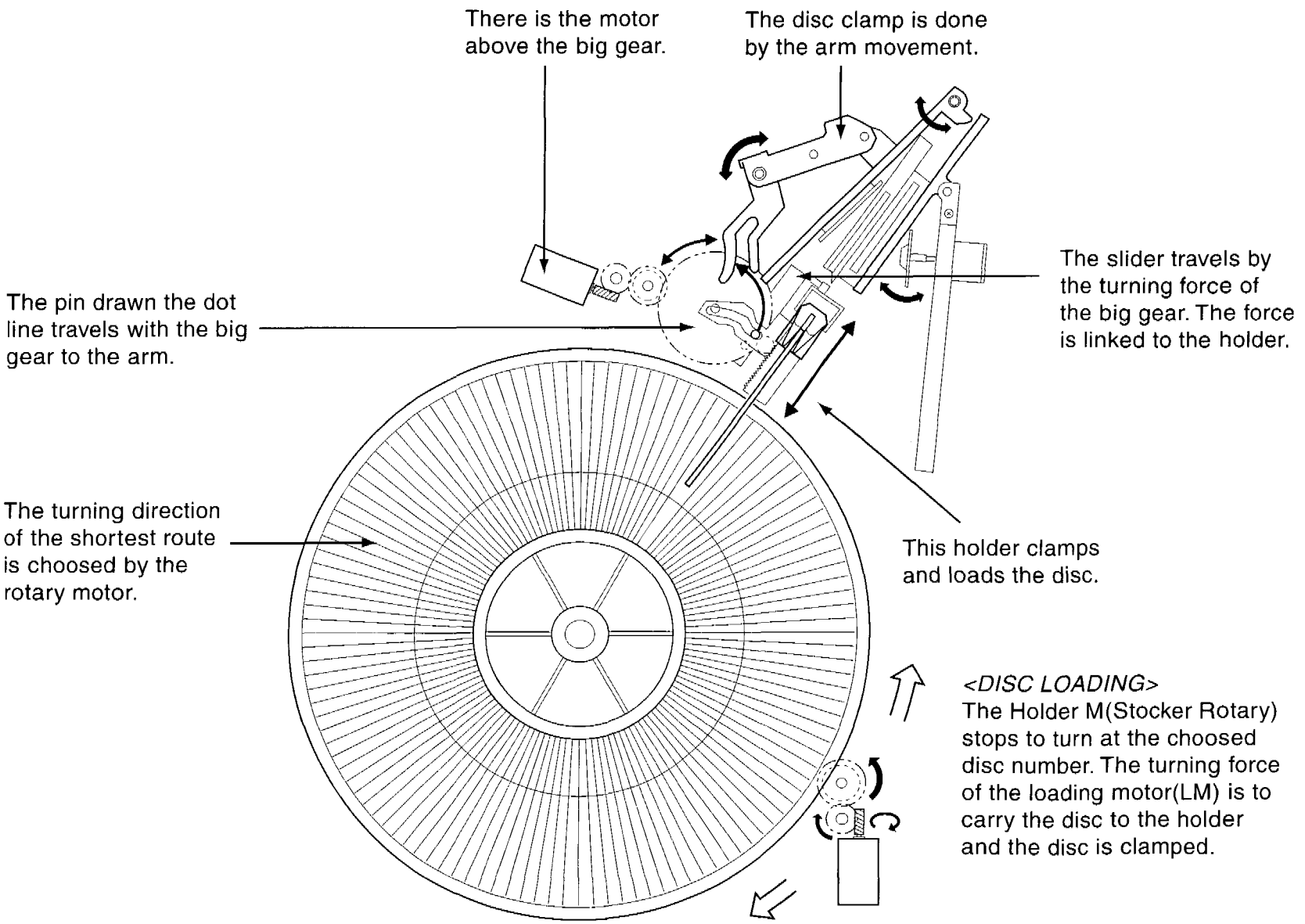

Illustration is CD-223M/DPF-J3010.

* Refer to parts list on page 19.

MECHANISM OPERATION DESCRIPTION



How to Assemble Mechanism.

1. Remove the lever(34) with the spring (72).
2. Slide the actuator assy(1+9) to the fully frontward.
3. Set the gear(33) to meet with the mark of its and the actuator assy(1+9).
4. Set the guide(37) to meet the mark of its and the gear(33).
5. Load the lever(34) with the spring (72) to the guide(37) after sliding the actuator assy(1+9) slightly backwards.

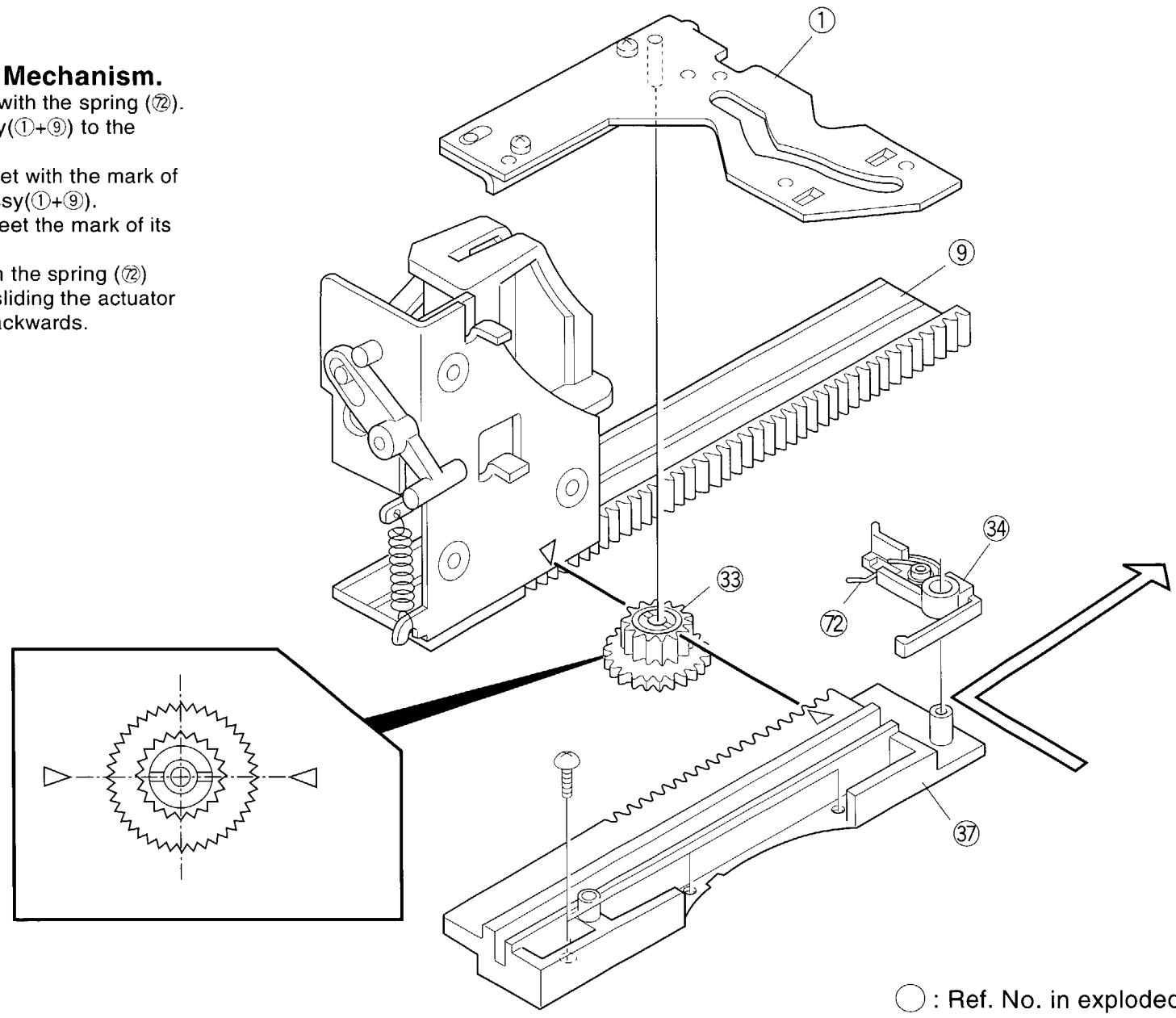

○ : Ref. No. in exploded view

CD-223M/224M/DPF-J3010/J5010

CIRCUIT DESCRIPTION

1. Main microprocessor : uPD784215GF509 (IC8) CD-2260M/2280M/DPF-J7010/J9010
 : uPD784214GF501 (IC8) CD-223M/224M/DPF-J3010/J5010

1-1 Microprocessor periphery block diagram

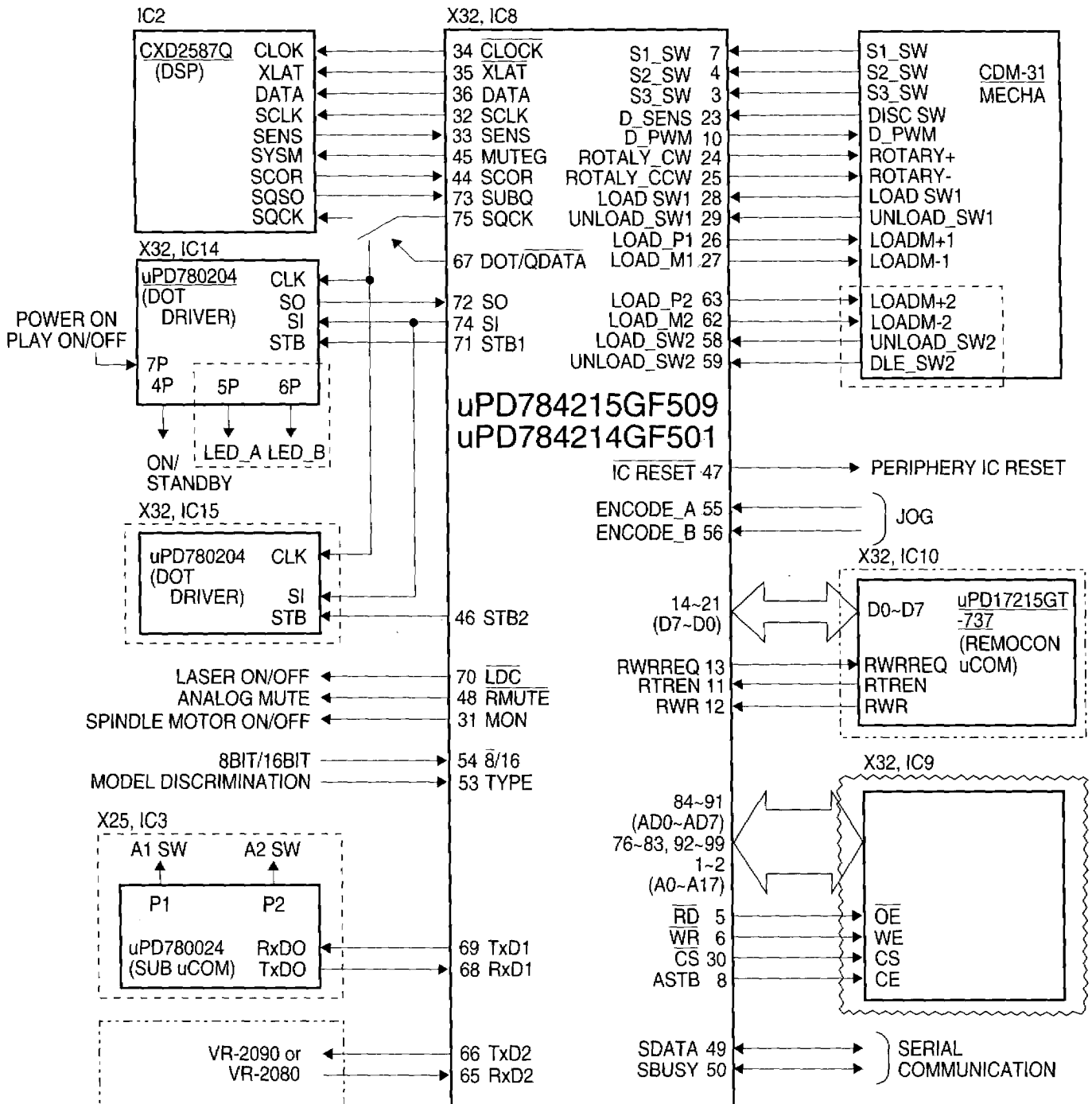

CD-2280M/DPF-J9010 only

CD-2260M/DPF-J7010 only
 CD-2280M/DPF-J9010

CD-2260M/2280M/DPF-J7010/J9010 (M5M5108BFP-70LL)
 CD-223M/224M/DPF-J3010/J5010 (HM62256BLFP-8T)

CD-223M/224M/DPF-J3010/J5010

CIRCUIT DESCRIPTION

1-2 Pin description

Pin No.	Pin Name	I/O	Description	
1*	A16	O	No connection.	
1	A2	O	Address buss of SRAM.	
2*	A17	O	No connection.	
2	NC	-	No connection.	
3	S3-SW	I	Mechanism address detector switch.	
4	S2-SW	I	Mechanism address detector switch.	
5	RD	O	SRAM read strobe.	
6	WR	O	SRAM write strobe	
7	S1-SW	I	Mechanism address detector switch.	
8	ASTB	O	No connection.	
9	VDD	-	Power supply (+5V).	
10	+5VPUL	O	Disc sensor PWM output.	
11*	RTRN	O	No connection.	
11	RTRN	I	TX permission data to remote control microprocessor.	
12*	RWR	O	No connection.	
12	RWR	I	Reading data of remote control microprocessor.	
13*	RWRR	O	No connection.	
13	RWRR	O	TX request data to remote control microprocessor.	
14-21*	L-D0-D7	O	No connection.	
14-21	L-D7-D0	O	Data output to remote control microprocessor.	
22	TEST	-	GND.	
23	DISC-SW	I	Disc sensor.	
24	ROTARY-CW	O	Mechanism rotary motor (+).	H : CCW
25	ROTARY-CCW	O	Mechanism rotary motor (-).	H : CW
26	LOADM+1	O	Loading motor (+) for main pickup.	
27	LOADM-1	O	Loading motor (-) for main pickup.	
28	LOAD-SW1	I	Loading switch for main pickup.	
29	UNLOAD-SW1	I	Unloading switch for main pickup.	
30	CE/CS	O	Chip selector	
31	MON	O	Control port of poor focus works.	
32	SCLK	O	Sens serial data read clock.	
33	SENS	I	SENS signal input.	
34	CLOCK	O	Serial data clock.	
35	XLAT	O	CXD2587Q latch.	
36	DATA	O	Serial data output.	
37	VDD	-	Power supply (+5V).	
38, 39	X1, 2	-	Main system clock (12.5MHz).	
40	VSS	-	GND.	
41	XT2	-	No connection.	
42	XT1	I	GND.	
43	RESET	I	System reset signal input.	
44	SCOR	I	Sub code synchro detection.	
45	MUTEG	O	Muting control output.	H : MUTE ON.
46	STB2	O	Strobe signal output to dot driver2 (DPF-J9010 only).	
47	IC RESET	O	IC reset.	
48	RMUTE	O	Analog mute.	L : MUTE ON.

* CD-223M/224M/DPF-J3010/J5010

CIRCUIT DESCRIPTION

Pin No.	Pin Name	I/O	Description	
49	SDATA	I/O	Serial data signal I/O.	
50	SBUSY	I/O	Serial busy signal I/O.	
51	AVDD	-	Power supply(+5V).	
52	AVREF	-	A/D reference power supply.	
53	A/D0	I	Model selector.	
54	8/16	I	8/16 bit selector. H:16bit.	
55	JOG2	I	Encoder signal A input.	
56	JOG1	I	Encoder signal B input.	
57	DOOR-SW	I	Door open/close detector switch.	
58	LOAD-SW2	I	Load switch2 for sub pickup(DPF-J9010 only).	
59	UNLOAD-SW2	I	Unload switch2 for sub pickup(DPF-J9010 only).	
60	DISC-SW2	I	Disc2 sensor(DPF-J7010/J9010 only).	
61	VSS	-	GND.	
62	LOADM-2	O	Load motor(-) for sub pickup(DPF-J9010 only).	
63	LOADM+2	O	Load motor(+) for sub pickup(DPF-J9010 only).	
64	AVREF1	-	D/A reference power supply.	
△	65	RXD2	I	UART communication input(DPF-J7010/J9010 only)
	66	TXD2	O	UART communication output(DPF-J7010/J9010 only)
	67	SQCK/SCK-SW	O	"SQCK,SCK(DOT/DSP clock) selector. L:DSP."
△	68	RXD1	I	UART communication input(sub u-com)(DPF-J9010 only).
	69	TXD1	O	UART communication output(sub u-com)(DPF-J9010 only).
	70	LDC	O	Laser on/off.
	71	STB1	O	Strobe signal output to dot driver.
	72	S0	I	Data input from dot driver.
	73	SQS1	I	Sub code read data input.
	74	S1	O	Data output to dot driver.
	75	SCK/SQCK	O	Dot driver/sub code read clock.
	76-83*	A14-7	O	Address output to SRAM.
	76-83	A16,14,12,7-3	O	Address output to SRAM.
	84-91	D0-7	I/O	SRAM data buss.
	92-99*	A1-6,15	O	Address output to SRAM.
	92-99	A0,1,8-11,13,15	O	Address output to SRAM.
	100	VSS	-	GND.

* CD-223M/224M/DPF-J3010/J5010

△ I/O port : O (when no used this port)

1-3 Key matrix

() : IC14 Pin No.

VOLTAGE	KEY RETURN 0 (33)	KEY RETURN 1 (32)	KEY RETURN 2 (31)
4.166V	223M/J3010 CHECK/SPACE	223M/J3010 MODE	223M/J3010 BEST SEL. 224M/2260M/J5010/J7010 DISPLAY 2280M/J9010 OPERATION
3.333V	223M/J3010 CLEAR/DELETE	223M/J3010 SET	RANDOM
2.5V	223M/J3010 FB	223M/J3010 ENTER	CONFIRM
1.666V	223M/J3010 FF	REPEAT	223M/J3010 DISP/INS 2280M/J9010 CONT. PLAY
0.833V	DOWN	223M/J3010 P.MODE/CHARA 2280M/J9010 DISPLAY	PLAY/PAUSE
0V	UP	POWER	STOP

CD-223M/224M/DPF-J3010/J5010

CIRCUIT DESCRIPTION

2. FL Microprocessor : CD-223M/224M/2260M/2280M/DPF-J3010/J5010/J7010/J9010 (X32, IC14)

Pin description

Pin No.	Pin Name		I/O	Description			
	223M/J3010	CD-2260M/2280M/J7010/J9010		223M/224M/ J3010/J5010	2260M/2280M/J7010/J9010		
	224M/J5010	IC14		IC15		IC14	IC15
1	VDD		-	Power supply (+5V)			
2, 3	NC		-	No connection.			
4	STANDBY	LED-D	O	Standby LED control		No connection.	
5	LED-A	LED-M	O	No connection.	Main LED control		
6	LED-B	LED-S	O		Sub LED control		
7	POW-P	STANDBY	I/O	Timer sw on input.			
8, 9	NC		-	No connection.			
10	RESET		I	System reset input			
11, 12	X1, 2		-	Main system clock. (5MHz).			
13	VSS		-	GND.			
14	XT2		-	No connection.			
15	XT1		I	GND.			
16	VDD		-	Power supply (+5V)			
17	SCK		I	Serial clock.			
18	SO		O	Data output.			
19	SI		I	Data input.			
20-24	NC		-	No connection.			
25	AVSS		-	GND.			
26-30	A/D7~A/D3		-	GND.			
31~33	A/D2~A/D0		I	Key return signal input (2~0).	Ground		
34	AVDD		-	A/D analog power supply.			
35	AVREF		-	A/D reference power supply.			
36, 37	VSS		-	GND.			
38	REM		I	Remote control input.			
39	STB1	STB2	I	Strobe signal input.			
40	VSS		-	GND.			
41~45	NC		-	No connection.			
46	VDD		-	Power supply (+5V)			
47	NC		-	No connection.			
48~52	P1~5		O	FL control output. 1G (▶), 2G~16G (1- 1 to 5- 1).			
53~57	P6~10		O	FL control output. 2G~16G (1- 2 to 5- 2).			
58~62	P11~15		O	FL control output. 2G~16G (1- 3 to 5- 3).			
63, 64	P16, 17		O	FL control output. 2G~16G (1- 4 to 2- 4).			
65~69	P35~31		O	FL control output. 2G~16G (5- 7 to 1- 7).			
70~74	P30~26		O	FL control output. 2G~16G (5- 6 to 1- 6).			
75~78	P25~22		O	FL control output. 2G~16G (5-5 to 2-5).			
79	VLOAD		-	Negative power supply (-37.5V).			
80	P21		O	FL control output. 2G~16G (1-5).			
81, 82	P20, 19		O	FL control output. 2G~16G (5-4 , 4-4).			
83	NC		-	No connection.			
84	P18		O	FL control output. 2G~16G (3-4).			
85~92	9G~16G		O	FL control output. 9G~16G.			
93~100	8G~1G		O	FL control output. 8G~1G.			

CIRCUIT DESCRIPTION

3. TEST MODE (CD-223M/224M/2260M/2280M/DPF-J3010/J5010/J7010)

INPUT KEY	PROCEDURE	DISPLAY
Insert the AC plug to the wall outlet with pressing the SKIP-DOWN key.	INITIAL CONDITION <ul style="list-style-type: none"> • Disc No.1 moves to the center and clamp it. • Clear the memory of the SRAM. • Door opens. • Set the switch of TIMER ON PLAY to ON. • Set the switch of SYSTEM CONTROL to XS8. 	INITIAL OK!! MECH. INITIAL INITIAL NG TIMER, NG SER, NG
Insert the AC plug to the wall outlet with pressing the REPEAT key	CIRCUIT ADJUSTMENT <ul style="list-style-type: none"> • Open the door and load the disc to the Disc No.1. • Close the door. The unit changes to test mode "05" after clamping the disc. 	TEST ON
PLAY/PAUSE	Change the mode 05(tracking-on) and 03 (tracking-off) alternately by the PLAY key.	05 1 : 23 03 2 : 34
STOP	Stop the function.	00
UP	The pickup travels outwards.	MOTOR FORWARD
DOWN	The pickup travels inwards.	MOTOR REVERSE
RANDOM	Shows the result of self-adjustment. 07 EF/FB ← ↓ 08 TG/FG ↓ 09 FE/RF ↓ 10 TE/VC ——— Mode changes alternately by the RANDOM key.	07 XXX:XXX 08 XXX:XXX 09 XXX:XXX 10 XXX:XXX NG : blinking
DISPLAY	—	shows niagara mode
POWER	Check the transmission signal (Disc No.1 and Track No.99) of the remote controller. *DPF-J7010 only	
REPEAT	Playback PGM signal of the Track No.7,13,23,30,34 and 41 in the order. And release	
CONFIRM	Release the test mode.	
(TIMER PLAY SW)	Check the switch position.	TIMER ON, TIMER OFF
(SL16/XS8 SW)	Check the switch position.	16BIT, 8BIT
(TxD port)	Check the SL16-TEXT port. "TxD : H - RxD:L, TxD:L - RxD:H"	
Insert the AC plug to the wall outlet with pressing the UP key.	CHECK THE MECHANISM JAMMING. the order. Clamp the Disc No1,2,100,50,200 and 199 in the order.	
Insert the AC plug to the wall outlet with pressing the RANDOM key.	THE MECHANISM TEST MODE. Display shows NIAGARA until pressing any key.	
PLAY/PAUSE	Change the mode 05 (tracking-on) and 03 (tracking-off) alternately by the PLAY key.	05 1 : 23 03 2 : 34
STOP	Stop the function. Shows the result of self-adjustment. 07 EF/FB ← ↓ 08 TG/FG ↓ 09 FE/RF ↓ 10 TE/VC ——— Mode changes alternately by the STOP key.	07 XXX:XXX 08 XXX:XXX 09 XXX:XXX 10 XXX:XXX NG : blinking
UP	Arm Motor Load operation.	MOTOR LOAD
DOWN	Arm Motor Unload operation.	MOTOR UNLOAD
RANDOM	Rotary Motor Clockwise turning.	MOTOR CW
DISPLAY	Rotary Motor Counterclockwise turning.	MOTOR CCW

CD-223M/224M/DPF-J3010/J5010

CIRCUIT DESCRIPTION/ADJUSTMENT

INPUT KEY	PROCEDURE	DISPLAY
POWER	Check the transmission signal(Disc No.1 and Track No.99) of the remote controller. *DPF-J7010 only	
REPEAT	Playback PGM signal of the Track No.7,13,23,30,34 and 41 in the order.And release he test mode.	
CONFIRM	Release the test mode.	
(TIMER PLAY SW)	Check the switch position.	TIMER ON , TIMER OFF
(SL16/XS8 SW)	Check the switch position.	16BIT, 8BIT
(TxD port)	Check the SL16-TEXT port. TxD : H → RxD : L, TxD : L → RxD : H	

4. ERROR CODE

DISPLAY	ERROR CONTENTS
MECHA ERROR 01	No input of S3. The original position error of Disc Number.
MECHA ERROR 02	No input of S2. The turning direction error to counterclockwise
MECHA ERROR 03	No input of S1. The turning direction error to clockwise
MECHA ERROR 04	No input of main load sw.
MECHA ERROR 05	No input of main unload sw.
MECHA ERROR 06	No input of sub load sw. (DPF-J9010)
MECHA ERROR 07	No input of sub unload sw. (DPF-J9010)

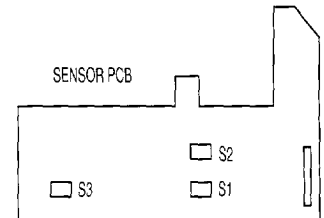

S1 DISC 1-9
S2 DISC 10-99
S3 DISC 100-200

S1-3:Mechanism address detector switch.
There are load and unload switches in the main pickup.

ADJUSTMENT

No.	ITEM	INPUT SETTING	OUTPUT SETTING	PLAYER SETTING	ALIGNMENT POINT	ALIGN FOR	FIG.
1. With pressing the RANDOM KEY, turn the power on to enter the test mode. 2. Set the Test disc to Disc NO. 1. 3. Close the door.							
1	FOCUS ERROR BIAS	Test disc Type4 /KTD-02	Connect an oscilloscope as follows. CH1:RF (CN2-1)	Press the PLAY /PAUSE key . Confirm that the display is "05".	FE BIAS VR1	Optimum eye pattern	(d)

Note:
Type 4 disc :SONY YEDS-18 Test Disc or equivalent.
LPF : Around 47kΩ + 390 pF or so.

FIG. (d)

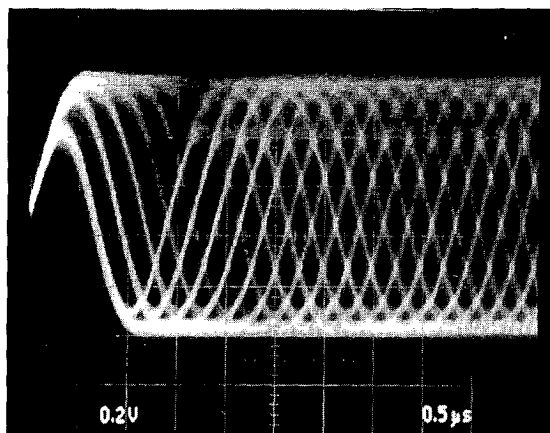

RF signal

- RF signal in test mode (PLAY).
- Perform the tangential and focusing offset are focused into one point on the display. The crossing points above and below the center shall also be looked clearly. (FE BIAS)

PC BOARD(Component side view)

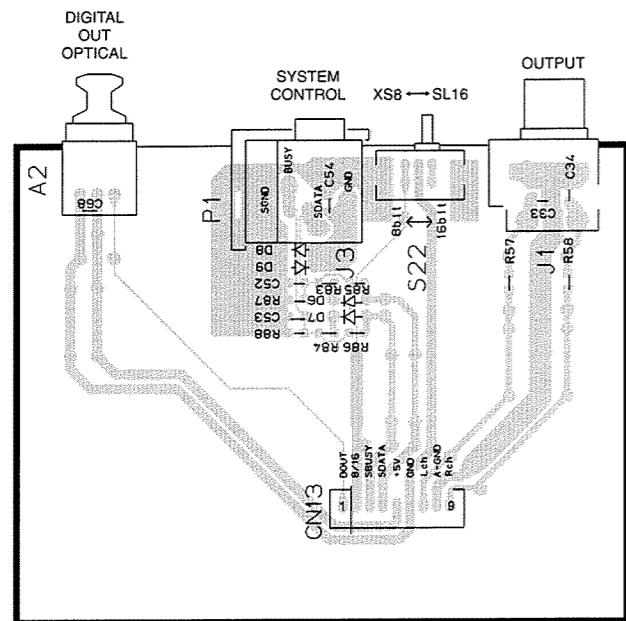

X32 B/5

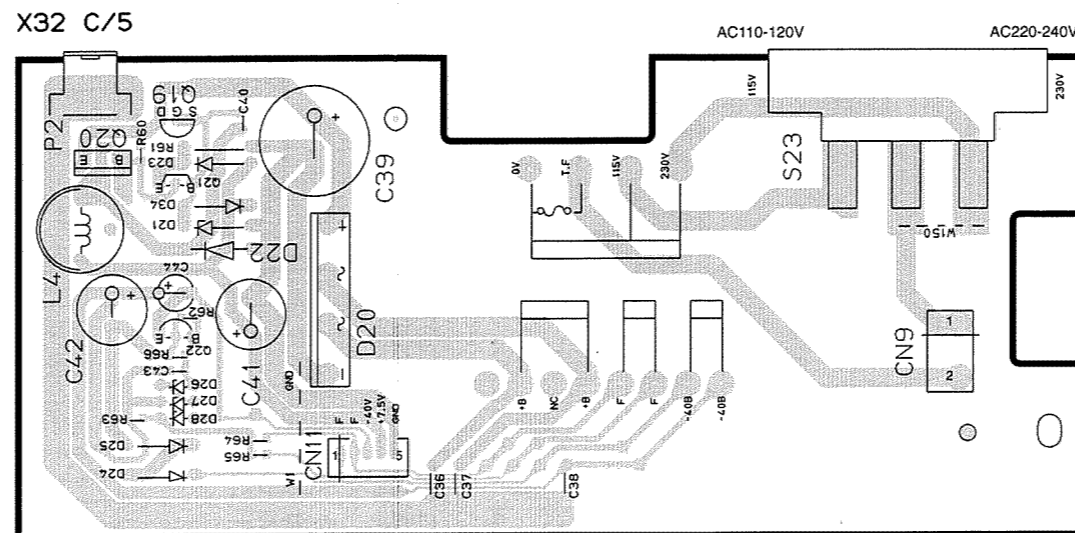

X32-356X-XX A/5 (J70-1140-11)

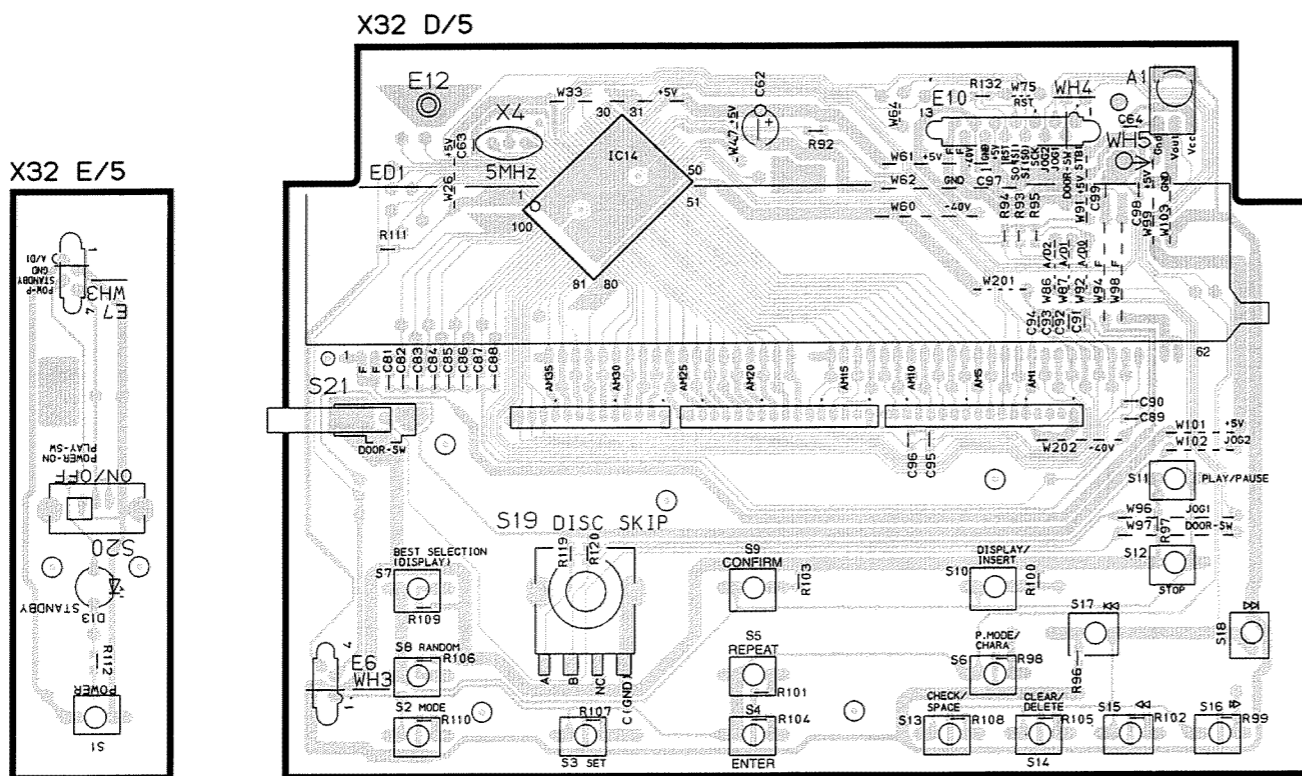
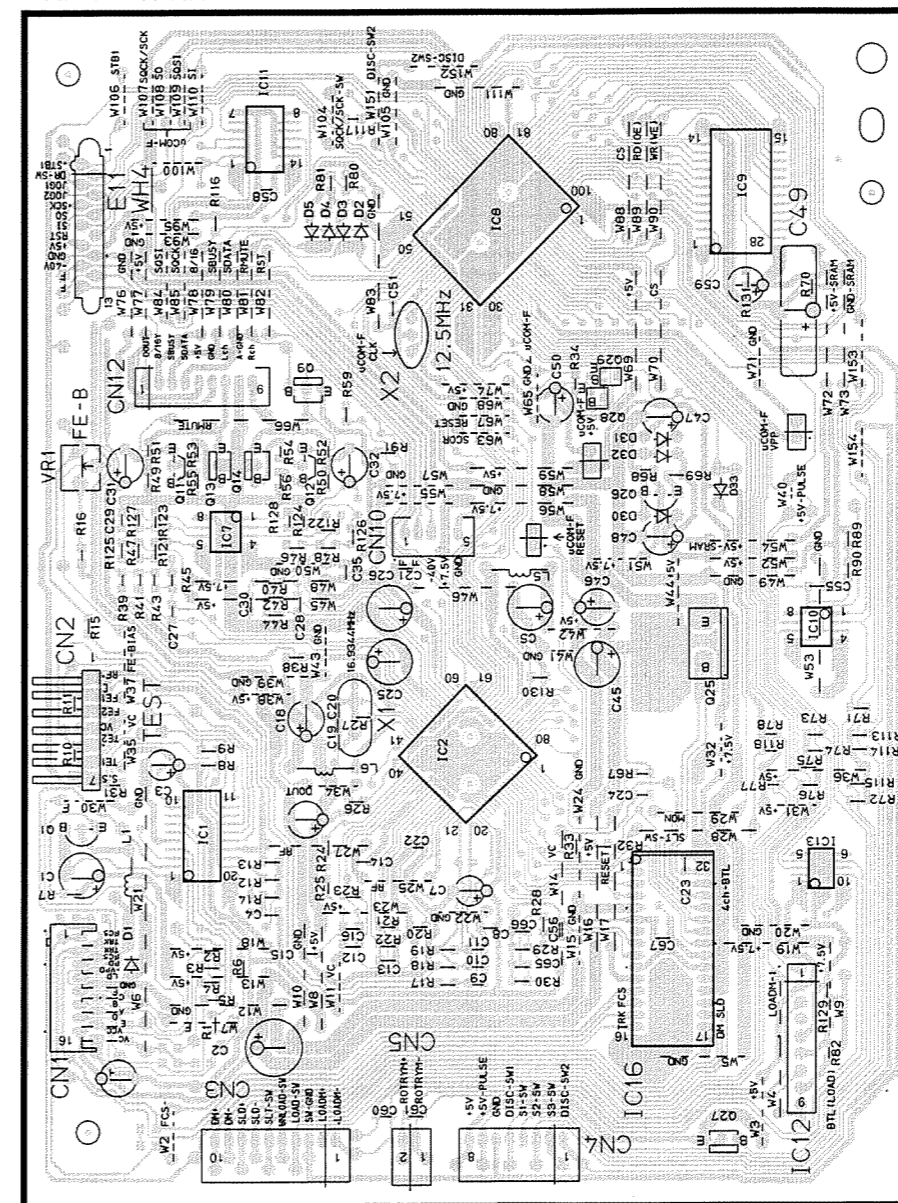

Refer to the schematic diagram for the value of resistors and capacitors.

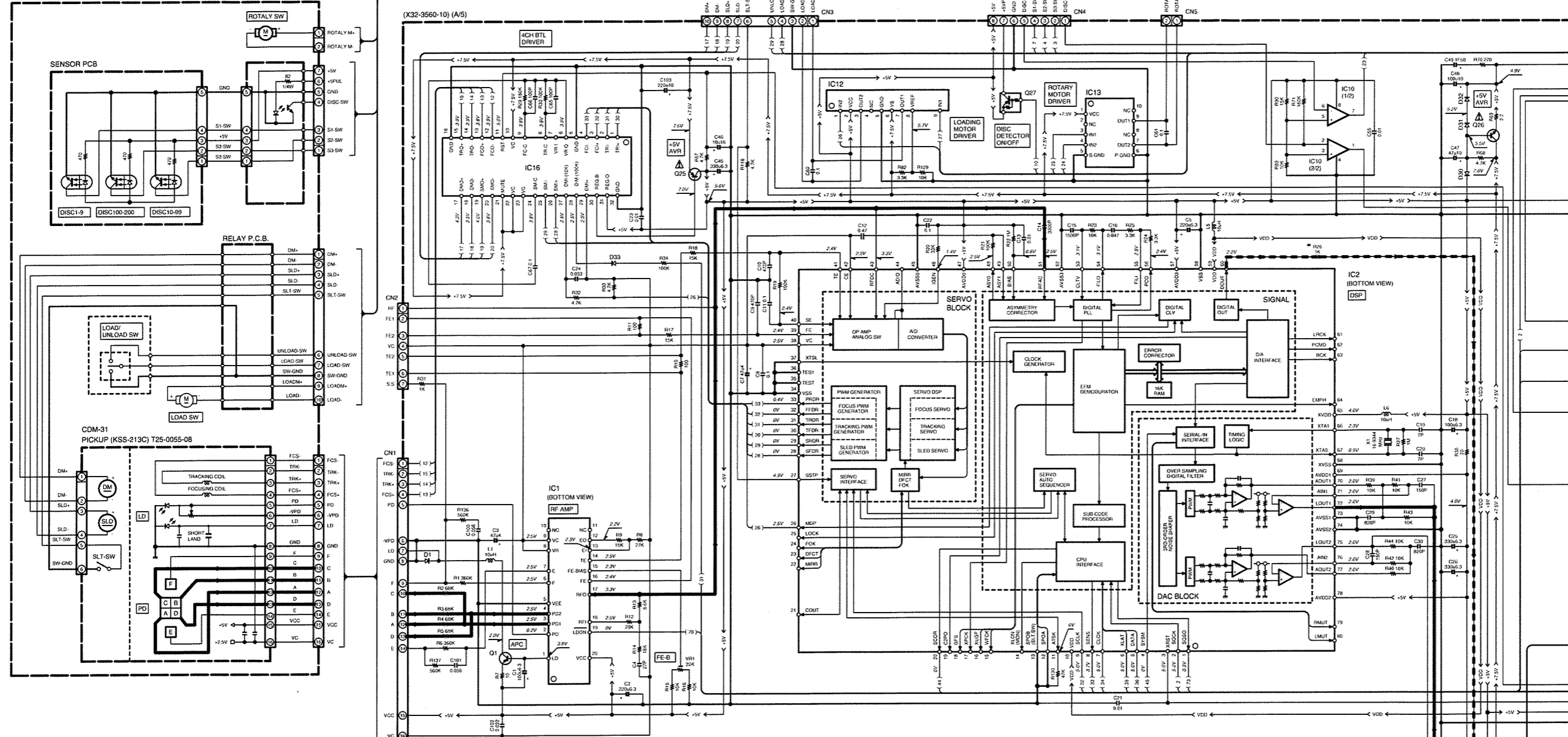

Legend:
 - - - DIGITAL LINE
 ——— SIGNAL LINE
 ——— GND LINE
 <-B- GND
 <-B- B LINE
 <-B- B LINE

CD-223M (X32-3560-10)										
DESTINATION	COUNTRY	ARB	UNIT No.	⊕	⊙	⊖	R06	R01	S23	W150
USA	USA	Y	0-10	NO	YES	NO	NO	NO	NO	YES
CANADA	CANADA	T		NO	YES	NO	NO	NO	NO	YES

DPP-3010 (X32-356X-XX)										
DESTINATION	COUNTRY	ARB	UNIT No.	⊕	⊙	⊖	R25	R01	S23	W150
GENERAL MARKET	USA	Y	0-21	NO	YES	NO	NO	NO	NO	YES
USA	USA	Y		NO	YES	NO	NO	NO	NO	YES
EUROPE	EUROPE	T	2-21	NO	YES	NO	NO	NO	NO	YES

CD-224M (X32-3560-11)										
DESTINATION	COUNTRY	ARB	UNIT No.	⊕	⊙	⊖	R06	R01	S23	W150
USA	USA	Y	0-11	YES	NO	NO	NO	NO	NO	YES
CANADA	CANADA	T		YES	NO	NO	NO	NO	NO	YES

DPP-3010 (X32-356X-XX)										
DESTINATION	COUNTRY	ARB	UNIT No.	⊕	⊙	⊖	R26	R01	S23	W150
USA	USA	Y	2-52	NO	NO	NO	NO	NO	NO	YES
UK	UK	T		YES	NO	NO	NO	NO	NO	YES
EUROPE	EUROPE	T	2-52	YES	NO	NO	NO	NO	NO	YES

IC1	: CXA1571M	D1-9,23,30-34
IC2	: CXD2587Q	: HSS104 or 1SS133
IC7	: NJM2115M	D13 : B30-2493-05
IC8	: uPD784214GF501	D20 : D3S8A20P03 or W242575-TOLL
IC9	: HM62256RFP-8T or RM4402FA	D21 : RD7.5S(B) or HZS7.5S(B)
IC10	: NJM2100M	D22 : DLM10C
IC11	: TC74HC00AF	D21,25 : S5688B or ISR158-400
IC12	: TA8409S	IC14 : uPD780204-034
IC13	: LB1930M	IC16 : BA5979S
Q1,22	: 2SA954(L,K)	D26 : RD20S(B) or HZS16N(B2)
Q9	: UN4212 or DTC124ESA	D27 : RD16S(B) or HZS20N(B)
Q11,12	: 2SA1309A(Q,R) or 2SA1048(Y,GR)	D28 : RD11ES(B2) or HZS11N(B2)
Q13,14	: 2SD1450(S,T)	E01 : 16-MT-63GK
Q19	: 2SK248(Y)	
Q20	: 2SB116S(R,S)	
Q21	: 2SC331(A,Q,R) or 2SC2458(Y,GR)	
Q25	: 2SB1640 or 2SB1417	
Q26	: 2SC2003(L,K)	
Q27	: UN4119 or DTA113Z2SA	
Q28	: UNS112 or DTA124EUA	
Q29	: UNS212 or DTC124EUA	

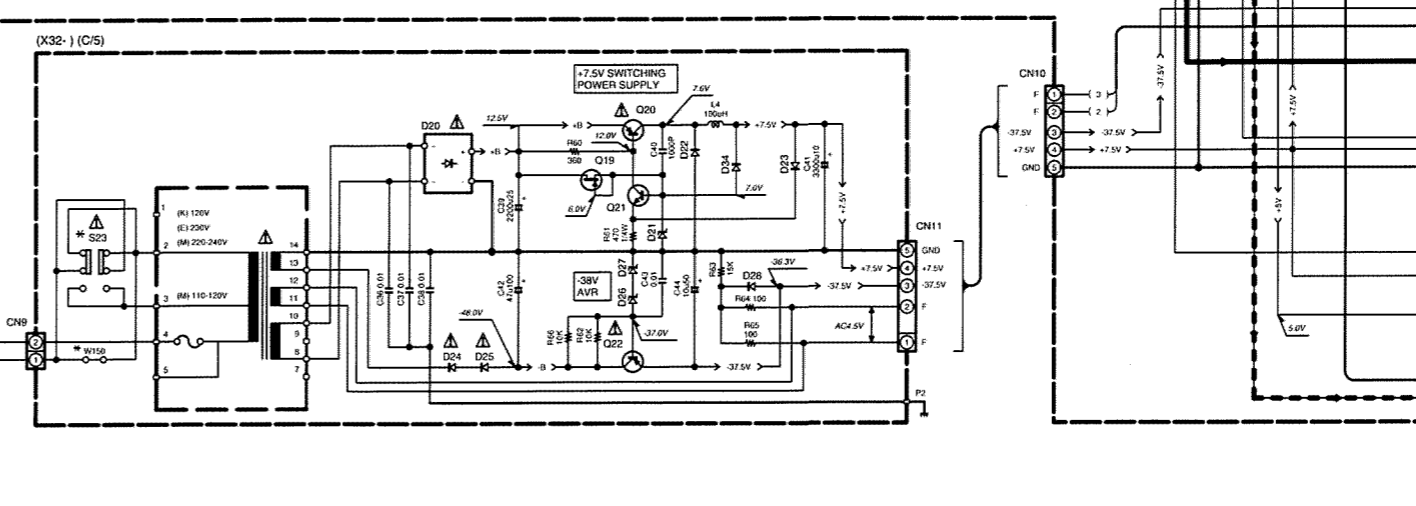

CAUTION: For continued safety, replace safety critical components only with manufacturer's recommended parts (refer to parts list). Δ indicates safety critical components. For continued protection against risk of fire, replace only with same type and rating fuse(s). To reduce the risk of electric shock, leakage-current or resistance measurements shall be carried out (exposed parts are acceptably insulated from the supply circuit) before the appliance is returned to the customer.

The DC voltage is an actual reading measured with a high impedance type voltmeter with no signal input. The measurement value may vary depending on the measuring instruments used or on the product.

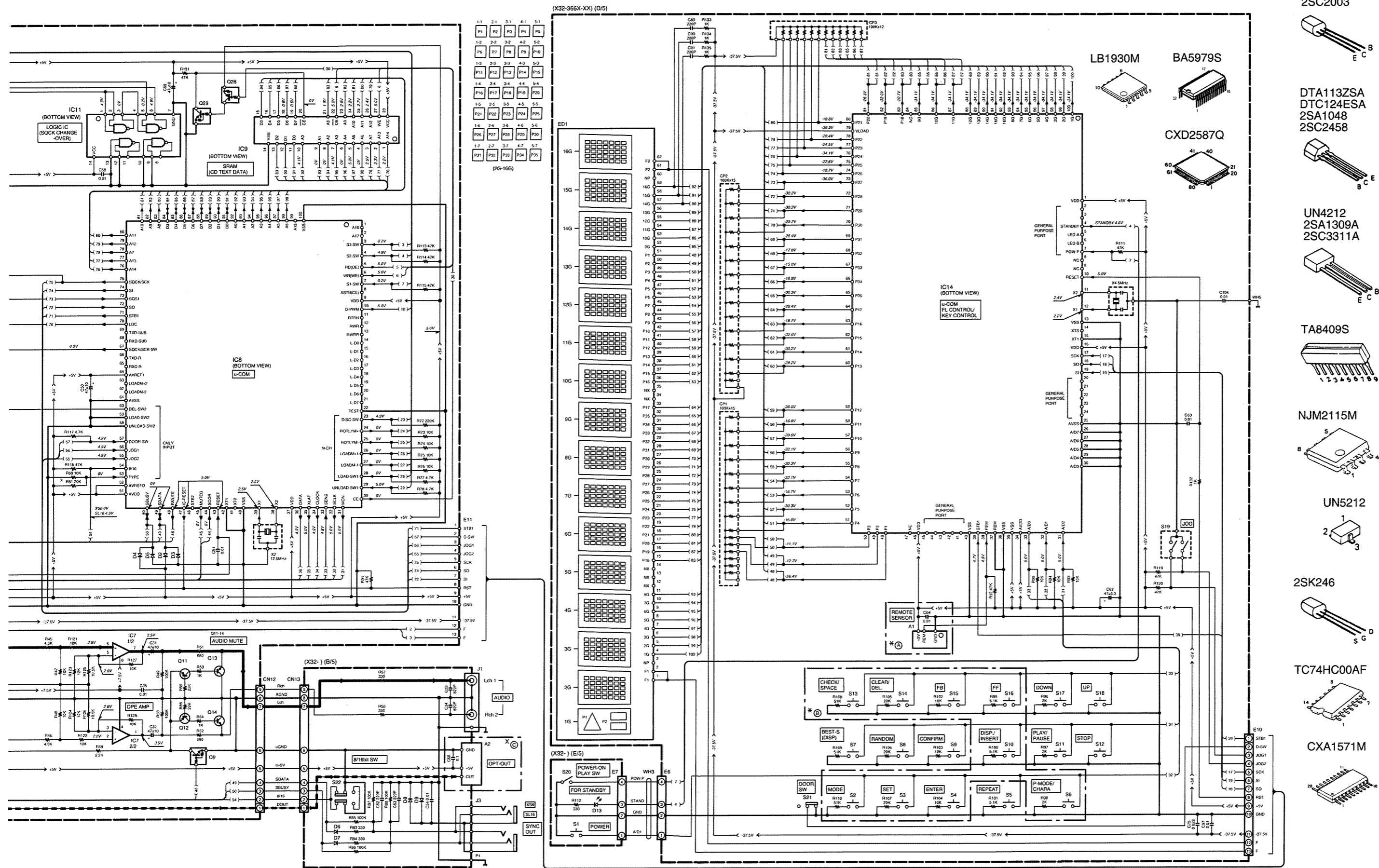

2SA954
2SC2003

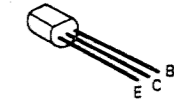

DTA113ZSA
DTC124ESA
2SA1048
2SC2458

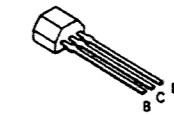

UN4212
2SA1309A
2SC3311A

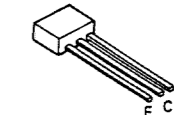

TA8409S



NJM2115M

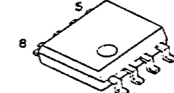

UN5212

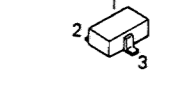

2SK246

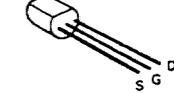

TC74HC00AF

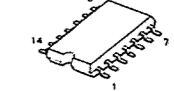

CXA1571M

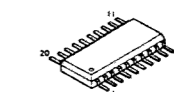

CD-223M/224M(K) DPF-J3010/J5010(M)

CD-223M/224M/DPF-J3010/J5010

Y22-7400-10

KENWOOD

EXPLODED VIEW(MECHANISM)

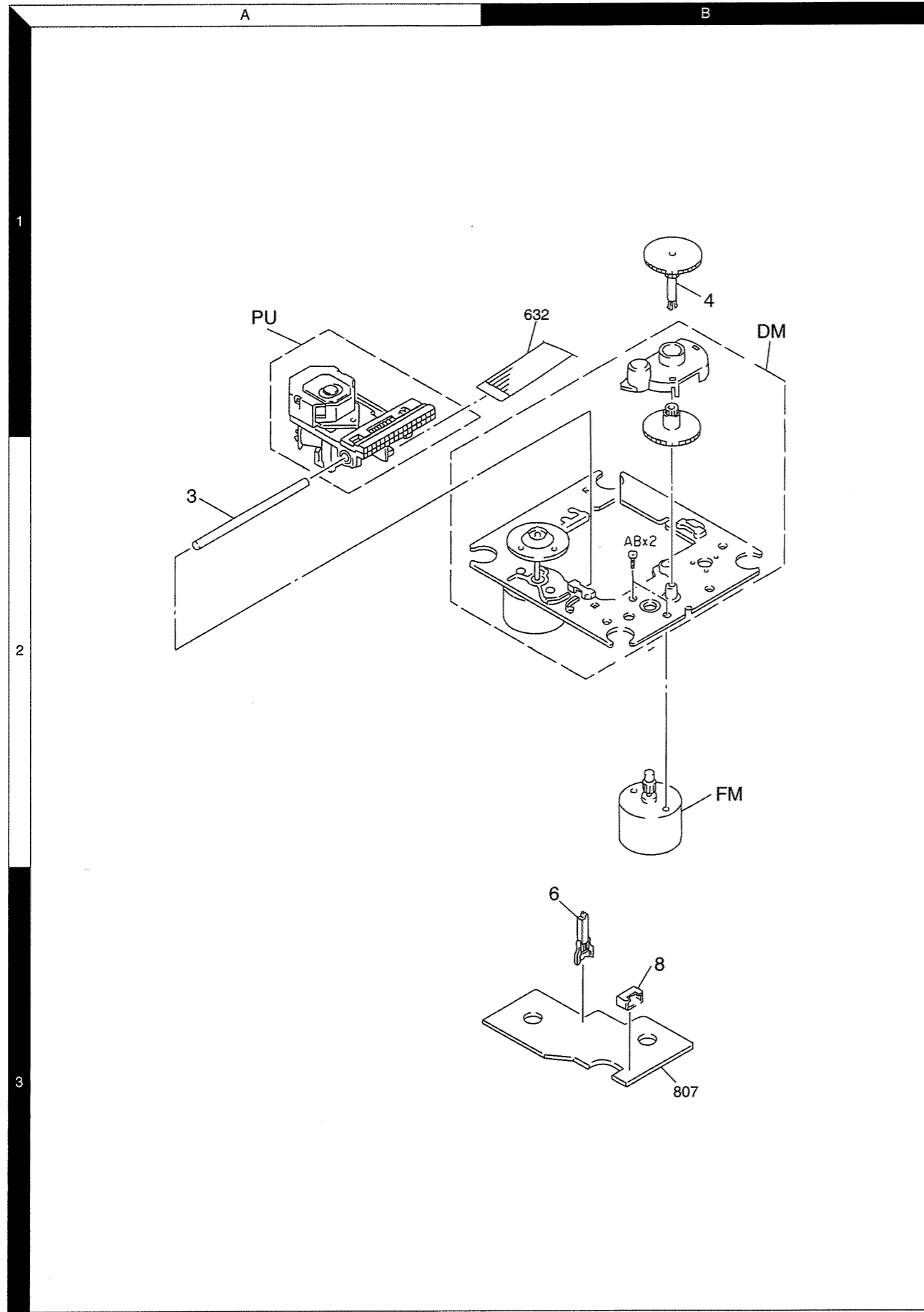

Parts with the exploded numbers larger than 700 are not supplied.

EXPLODED VIEW(UNIT)

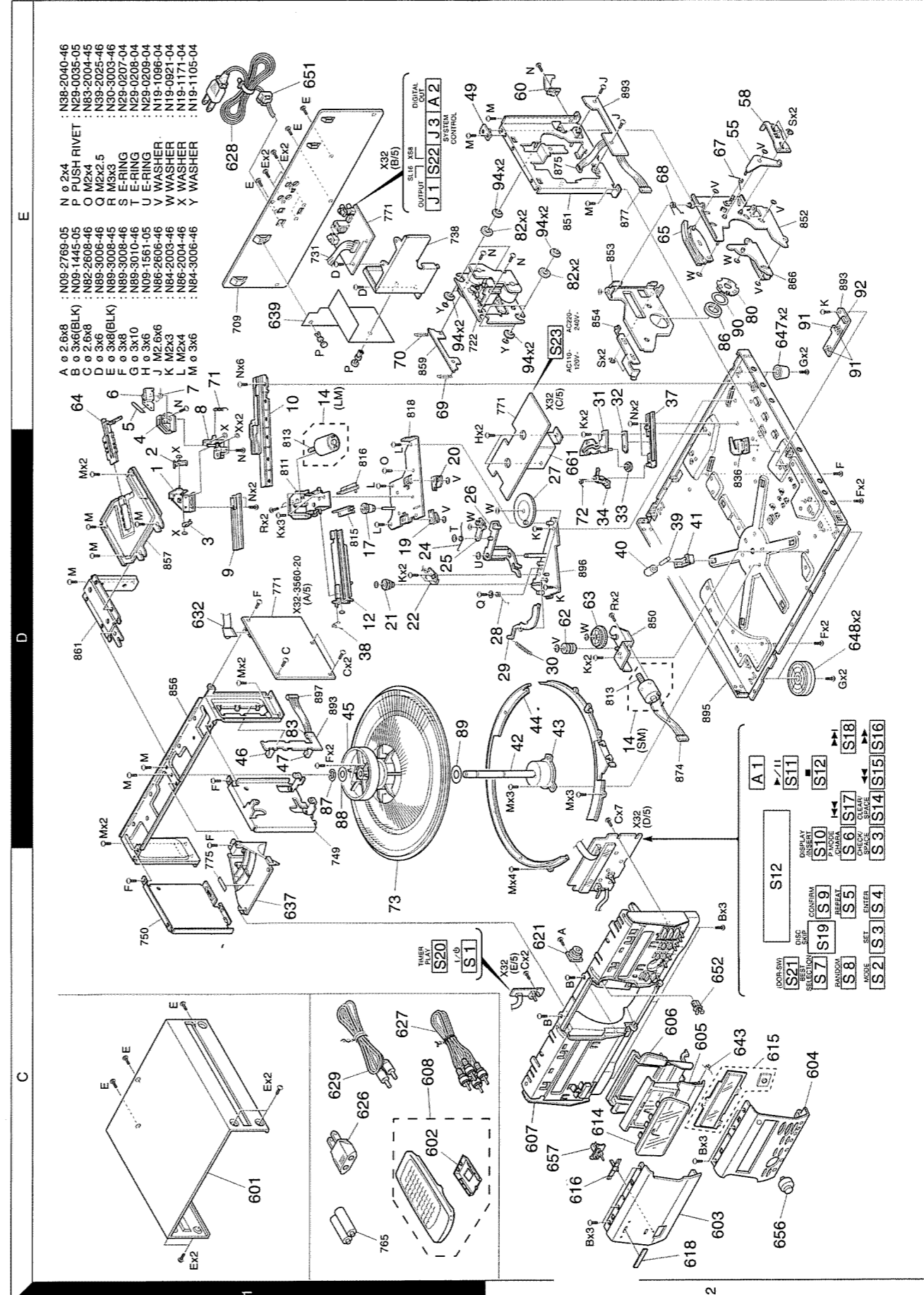

Parts with exploded view numbers larger than 700 are not supplied.
Parts with the exploded numbers smaller than 100 refer to the parts list of MECHANISM CHANGER.

* New Parts
Parts without **Parts No.** are not supplied.
Les articles non mentionnés dans le **Parts No.** ne sont pas fournis.
Teile ohne **Parts No.** werden nicht geliefert.

Ref. No	Add-ress	New Parts	Parts No.	Description	Desti-nation	Re-marks
CD-223M/224M/DPF-J3010/J5010						
601	1C	*	A01-3501-08	METALLIC CABINET		
602	1C	*	A09-0374-08	CABINET	X1	
602	1C	*	A09-0374-08	CABINET(BATTERY COVER)	K1P1M1	
602	1C	*	A09-0374-08	CABINET(BATTERY COVER)	T1E1Y1	
603	2C	*	A21-3605-18	DRESSING PANEL	K3P3	
603	2C	*	A21-3606-18	DRESSING PANEL	M3T3E3	
603	2C	*	A21-3609-18	DRESSING PANEL	K1P1	
603	2C	*	A21-3610-18	DRESSING PANEL	E1	
603	2C	*	A21-3610-18	DRESSING PANEL	M1X1T1	
603	2C	*	A21-3654-18	DRESSING PANEL	Y3	
603	2C	*	A21-3655-18	DRESSING PANEL	Y1	
604	2C	*	A21-3607-18	DRESSING PANEL	K3P3M3	
604	2C	*	A21-3607-18	DRESSING PANEL	T3E3Y3	
604	2C	*	A21-3611-18	DRESSING PANEL	K1P1M1	
604	2C	*	A21-3611-18	DRESSING PANEL	T1E1Y1	
604	2C	*	A21-3611-18	DRESSING PANEL	X1	
605	2C	*	A29-0886-18	PANEL(FRONT LID)		
606	2C	*	A46-0304-18	REAR COVER		
607	2C	*	A60-1260-18	PANEL	K1P1M1	
607	2C	*	A60-1260-18	PANEL	T1E1Y1	
607	2C	*	A60-1260-18	PANEL	X1	
607	2C	*	A60-1261-18	PANEL	K3P3M3	
607	2C	*	A60-1261-18	PANEL	T3E3Y3	
608	1C	*	A70-1175-08	REMOTE CONTROL ASSY(RC-P0306)	K1P1M1	
608	1C	*	A70-1175-08	REMOTE CONTROL ASSY(RC-P0306)	T1E1Y1	
608	1C	*	A70-1175-08	REMOTE CONTROL ASSY(RC-P0306)	X1	
614	2C	*	B10-2395-08	FRONT GLASS (DOOR)	K1P1M1	
614	2C	*	B10-2395-08	FRONT GLASS (DOOR)	T1E1Y1	
614	2C	*	B10-2395-08	FRONT GLASS (DOOR)	X1	
614	2C	*	B10-2485-08	FRONT GLASS (DOOR)	K3P3M3	
614	2C	*	B10-2485-08	FRONT GLASS (DOOR)	T3E3Y3	
615	2C	*	B10-2396-08	FRONT GLASS (FL)	K1P1Y1E1	
615	2C	*	B10-2456-08	FRONT GLASS (FL)	K3P3M3	
616	2C	*	B12-0337-08	INDICATOR		
618	2C	*	B43-0302-04	KENWOOD BADGE		
			B46-0096-53	WARRANTY CARD	X1	
			B46-0197-00	QUESTIONNAIRE CARD	K1	
			B46-0197-00	QUESTIONNAIRE CARD	K3	
			B46-0310-03	WARRANTY CARD	T1E1	
			B46-0310-03	WARRANTY CARD	T3E3	
			B46-0328-03	WARRANTY CARD	K1Y1	
			B46-0328-03	WARRANTY CARD	K3Y3	
			B46-0336-03	WARRANTY CARD	P1	
			B46-0336-03	WARRANTY CARD	P3	
			B58-0513-04	CAUTION CARD (PRESET220-240)	Y1	
			B58-0513-04	CAUTION CARD (PRESET220-240)	Y3	
			B58-0964-13	CAUTION CARD (UL)	K1Y1	
			B58-0964-13	CAUTION CARD (UL)	K3Y3	
		*	B58-0965-13	CAUTION CARD (T,XtypePL)	T3	
		*	B58-0965-13	CAUTION CARD (T,XtypePL)	X1T1	
		*	B58-0966-13	CAUTION CARD (ELMtypePL)	M1E1	
		*	B58-0966-13	CAUTION CARD (ELMtypePL)	M3E3	
		*	B58-0967-03	CAUTION CARD (PtypePL)	P1	

L: Scandinavia K: USA P: Canada R: Mexico C: China I: Malaysia
Y: PX(Far East, Hawaii) T: Europe E: Europe G: Germany V: China (Shanghai)
Y: AAFES(Europe) X: Australia Q: Russia H: Korea M: Other Areas Δ indicates safety critical components.

* New Parts
Parts without **Parts No.** are not supplied.
Les articles non mentionnés dans le **Parts No.** ne sont pas fournis.
Teile ohne **Parts No.** werden nicht geliefert.

Ref. No	Add-ress	New Parts	Parts No.	Description	Desti-nation	Re-marks
		*	B58-0967-03	CAUTION CARD (PtypePL)	P3	
		*	B59-1104-00	SERVICE DIRECTORY	Y1	
		*	B59-1104-00	SERVICE DIRECTORY	Y3	
		*	B60-3503-08	INSTRUCTION MANUAL(ENGLISH)	K3P3Y3	
		*	B60-3503-08	INSTRUCTION MANUAL(ENGLISH)	M3T3	
		*	B60-3504-08	INSTRUCTION MANUAL(FRENCH)	P3E3	
		*	B60-3505-08	INSTRUCTION MANUAL(SPANISH)	M3E3	
		*	B60-3510-08	INSTRUCTION MANUAL(ENGLISH)	K1P1Y1	
		*	B60-3510-08	INSTRUCTION MANUAL(ENGLISH)	M1X1T1	
		*	B60-3511-08	INSTRUCTION MANUAL(FRENCH)	P1E1	
		*	B60-3512-08	INSTRUCTION MANUAL(SPANISH)	M1E1	
		*	B60-3513-08	INSTRUCTION MANUAL(G.D.I)	E1	
621	2C	*	D39-0335-08	DAMPER		
Δ 626	1C		E03-0115-05	AC PLUG ADAPTER	M1	
Δ 626	1C		E03-0115-05	AC PLUG ADAPTER	M3	
Δ 627	1C		E30-0505-05	AUDIO CORD		
Δ 628	1E		E30-2787-05	AC POWER CORD	K1P1	
Δ 628	1E		E30-2787-05	AC POWER CORD	K3P3	
Δ 628	1E		E30-2788-05	AC POWER CORD	M1E1	
Δ 628	1E		E30-2788-05	AC POWER CORD	M3E3	
Δ 628	1E		E30-2789-05	AC POWER CORD	Y1	
Δ 628	1E		E30-2789-05	AC POWER CORD	Y3	
Δ 628	1E		E30-2790-05	AC POWER CORD	X1	
Δ 628	1E		E30-2791-05	AC POWER CORD	T1	
Δ 628	1E		E30-2791-05	AC POWER CORD	T3	
629	1C		E30-2816-05	CORD WITH PLUG (SYNCR0)		
632	1D	*	E35-2079-08	WIRING HARNESS (FFC)		
637	1C	*	F07-1613-08	COVER		
639	1E	*	F20-3515-08	INSULATING BOARD		
643	2C	*	G01-4026-18	TORSION COIL SPRING		
		*	H10-7397-08	POLYSTYRENE FOAMED FIXTURE		
		*	H10-7398-08	POLYSTYRENE FOAMED FIXTURE		
		*	H12-2401-08	PACKING FIXTURE		
		*	H20-0580-04	PROTECTION COVER	M1	
		*	H20-0580-04	PROTECTION COVER	M3	
		*	H21-0359-08	PROTECTION SHEET		
		*	H25-0232-04	PROTECTION BAG (235X350X0.03)	K1P1Y1	
		*	H25-0232-04	PROTECTION BAG (235X350X0.03)	K3P3Y3	
		*	H25-0232-04	PROTECTION BAG (235X350X0.03)	M1X1E1	
		*	H25-0232-04	PROTECTION BAG (235X350X0.03)	M3E3	
		*	H25-0651-04	PROTECTION BAG (0232 PRINT)	T1	
		*	H25-0651-04	PROTECTION BAG (0232 PRINT)	T3	
		*	H25-0692-04	PROTECTION BAG	K1P1Y1	
		*	H25-0692-04	PROTECTION BAG	K3P3Y3	
		*	H25-0692-04	PROTECTION BAG	T3E3	
		*	H25-0692-04	PROTECTION BAG	X1T1E1	
		*	H50-2614-08	ITEM CARTON CASE	K3P3	
		*	H50-2615-08	ITEM CARTON CASE	M3	
		*	H50-2616-08	ITEM CARTON CASE	K1P1	
		*	H50-2617-08	ITEM CARTON CASE	M1	
		*	H50-2759-08	ITEM CARTON CASE	Y3T3E3	
		*	H50-2760-08	ITEM CARTON CASE	E1	

L: Scandinavia K: USA P: Canada R: Mexico C: China I: Malaysia
Y: PX(Far East, Hawaii) T: Europe E: Europe G: Germany V: China (Shanghai)
Y: AAFES(Europe) X: Australia Q: Russia H: Korea M: Other Areas Δ indicates safety critical components.

PARTS LIST

CD-223M/224M/DPF-J3010/J5010

PARTS LIST

* New Parts
Parts without **Parts No.** are not supplied.
Les articles non mentionnés dans le **Parts No.** ne sont pas fournis.
Teile ohne **Parts No.** werden nicht geliefert.

3

Ref. No	Add-ress	New Parts	Parts No.	Description	Desti-nation	Re-marks
-		*	H50-2760-08	ITEM CARTON CASE	Y1X1T1	
647	2E		J02-1067-05	FOOT (REAR)		
648	2D	*	J02-1404-13	FOOT (FRONT) (D=46,H=18.5,T)		
651	1E		J42-0083-05	POWER CORD BUSHING		
652	2C		J52-0039-05	PUSH LATCH		
			J19-0356-05	UNIT HOLDER		
			J61-0098-05	WIRE BAND		
656	2C		K29-6824-08	KNOB (DISC SKIP)		
657	2C		K29-6885-08	KNOB (TIMER REC)		
661	2D		L07-2449-08	POWER TRANSFORMER	K1P1	
661	2D	*	L07-2449-08	POWER TRANSFORMER	K3P3	
661	2D		L07-2450-08	POWER TRANSFORMER	Y1M1	
661	2D	*	L07-2450-08	POWER TRANSFORMER	Y3M3	
661	2D	*	L07-2451-08	POWER TRANSFORMER	T3E3	
661	2D		L07-2451-08	POWER TRANSFORMER	X1T1E1	
CD PLAYER UNIT (X32-356X-XX)						
D13			B30-2493-05	LED(RE D)		
C1			C90-3214-05	ELECTRO 100UF 6.3WV		
C2			C90-3215-05	ELECTRO 220UF 6.3WV		
C3			C90-3203-05	ELECTRO 47UF 4WV		
C4			CC73FSL1H270J	CHIP C 27PF J		
C5			CE04KW0J221M	ELECTRO 220UF 6.3WV		
C7			C90-3203-05	ELECTRO 47UF 4WV		
C8			CK73FB1E104K	CHIP C 0.10UF K		
C9 , 10			CC73FSL1H471J	CHIP C 470PF J		
C11			CK73FB1E104K	CHIP C 0.10UF K		
C12			CK73FB1C474K	CHIP C 0.47UF K		
C13			CK73FB1H103K	CHIP C 0.010UF K		
C14			CK73FB1H332K	CHIP C 3300PF K		
C15			CK73FB1H152K	CHIP C 1500PF K		
C16			CK73FB1H473K	CHIP C 0.047UF K		
C18			C90-3214-05	ELECTRO 100UF 6.3WV		
C19 , 20			CC73FCH1H070D	CHIP C 7.0PF D		
C21			CK73FB1H103K	CHIP C 0.010UF K		
C22			CK73FB1E104K	CHIP C 0.10UF K		
C23			CK73FB1H103K	CHIP C 0.010UF K		
C24			CK73FB1H333K	CHIP C 0.033UF K		
C25 , 26			CE04KW0J331M	ELECTRO 330UF 6.3WV		
C27 , 28			CC73FSL1H151J	CHIP C 150PF J		
C29 , 30			CC73FSL1H821J	CHIP C 820PF J		
C31 , 32			CE04KW1A470M	ELECTRO 47UF 10WV		
C33 , 34			CC73FSL1H821J	CHIP C 820PF J		
C35			CK73FB1H103K	CHIP C 0.010UF K		
C36 - 38			CK45FF1H103Z	CERAMIC 0.010UF Z		
C39			CE04KW1E222M	ELECTRO 2200UF 25WV		
C40			CK73FB1H102K	CHIP C 1000PF K		
C41			CE04KW1A332M	ELECTRO 3300UF 10WV		
C42			CE04KW2A470M	ELECTRO 47UF 100WV		
C43			CK73FB1H103K	CHIP C 0.010UF K		
C44			CE04KW1H100M	ELECTRO 10UF 50WV		
C45			CE04KW0J331M	ELECTRO 330UF 6.3WV		
C46			CE04KW1C100M	ELECTRO 10UF 16WV		

L : Scandinavia K : USA P : Canada R : Mexico C : China I : Malaysia
Y : PX(Far East, Hawaii) T : Europe E : Europe G : Germany V : China (Shanghai)
Y : AAFES(Europe) X : Australia Q : Russia H : Korea M : Other Areas Δ indicates safety critical components.

* New Parts
Parts without **Parts No.** are not supplied.
Les articles non mentionnés dans le **Parts No.** ne sont pas fournis.
Teile ohne **Parts No.** werden nicht geliefert.

4

Ref. No	Add-ress	New Parts	Parts No.	Description	Desti-nation	Re-marks
C47			CE04KW1A470M	ELECTRO 47UF 10WV		
C48			CE04KW1A101M	ELECTRO 100UF 10WV		
C49			C90-3542-05	SUPER-C 1.0F 5.5WV		
C50			CE04KW1A470M	ELECTRO 47UF 10WV		
C51			CK73FB1H103K	CHIP C 0.010UF K		
C52 , 53			CC73FSL1H221J	CHIP C 220PF J		
C54			CK73FB1H103K	CHIP C 0.010UF K		
C55			CK73FB1H103K	CHIP C 0.010UF K		
C58			CK73FB1H103K	CHIP C 0.010UF K		
C59			CE04KW1A470M	ELECTRO 47UF 10WV		
C60 , 61			CK73FB1E104K	CHIP C 0.10UF K		
C62			C90-3212-05	ELECTRO 47UF 6.3WV		
C63			CK73FB1H103K	CHIP C 0.010UF K		
C64			CK73FB1H103K	CHIP C 0.010UF K	K1P1M1	
C64			CK73FB1H103K	CHIP C 0.010UF K	T1E1Y1	
C64			CK73FB1H103K	CHIP C 0.010UF K	X1	
C65 , 66			CC73FSL1H101J	CHIP C 100PF J		
C67			CK73FB1E104K	CHIP C 0.10UF K		
C68			CK73FB1E104K	CHIP C 0.10UF K	E1T1M1	
C68			CK73FB1E104K	CHIP C 0.10UF K	E3T3M3	
C75			CK73FB1H223K	CHIP C 0.022UF K		
C89 - 91			CC73FSL1H221J	CHIP C 220PF J		
C97			CK73FB1H103K	CHIP C 0.010UF K		
C98			CK73FB1E104K	CHIP C 0.10UF K		
C100 , 101			CK73FB1H563K	CHIP C 0.056UF K		
C102			CK73FB1H223K	CHIP C 0.022UF K		
C103			C90-3223-05	ELECTRO 220UF 10WV		
C104			CK73FB1H103K	CHIP C 0.010UF K		
CN1			E40-4997-05	FLAT CABLE CONNECTOR		
CN2			E40-4979-05	PIN ASSY		
CN3			E40-3268-05	PIN ASSY		
CN4			E40-3265-05	PIN ASSY		
CN5			E40-3260-05	PIN ASSY		
CN9			E40-4245-05	PIN ASSY		
CN10 , 11			E40-3249-05	PIN ASSY		
CN12 , 13			E40-3253-05	PIN ASSY		
J1			E63-0122-05	PHONO JACK		
J3			E11-0293-05	MINI PHONE JACK(2P VERTICAL)		
-			J19-5789-04	HOLDER		
E12			J11-0808-05	WIRE CLAMPER		
L1			L40-1001-17	SMALL FIXED INDUCTOR(10UH,K)		
L4			L33-0558-05	CHOKE COIL		
L5 , 6			L40-1001-17	SMALL FIXED INDUCTOR(10UH,K)		
X1		*	L77-2226-05	CRYSTAL RESONATOR(16.9344MHZ)		
X2			L78-0615-05	RESONATOR (12.5MHZ)		
X4			L78-0284-05	RESONATOR (5MHZ)		
CP1 , 2			R90-0875-05	MULTI-COMP 100KX15		
CP3			R90-0479-05	MULTI-COMP 100KX12		
R1			RK73FB2A364J	CHIP R 360K J 1/10W		
R2 - 5			RK73FB2A683J	CHIP R 68K J 1/10W		
R6			RK73FB2A364J	CHIP R 360K J 1/10W		
R7			RK73FB2A100J	CHIP R 10 J 1/10W		
R8			RK73FB2A273J	CHIP R 27K J 1/10W		

L : Scandinavia K : USA P : Canada R : Mexico C : China I : Malaysia
Y : PX(Far East, Hawaii) T : Europe E : Europe G : Germany V : China (Shanghai)
Y : AAFES(Europe) X : Australia Q : Russia H : Korea M : Other Areas Δ indicates safety critical components.

* New Parts
 Parts without **Parts No.** are not supplied.
 Les articles non mentionnés dans le **Parts No.** ne sont pas fournis.
 Teile ohne **Parts No.** werden nicht geliefert.

5

Ref. No	Add-ress	New Parts	Parts No.	Description	Desti-nation	Re-marks
R9			RK73FB2A153J	CHIP R 15K J 1/10W		
R10 ,11			RK73FB2A101J	CHIP R 100 J 1/10W		
R12			RK73FB2A203J	CHIP R 20K J 1/10W		
R13			RK73FB2A562J	CHIP R 5.6K J 1/10W		
R14			RK73FB2A183J	CHIP R 18K J 1/10W		
R15 ,16			RK73FB2A103J	CHIP R 10K J 1/10W		
R17 ,18			RK73FB2A153J	CHIP R 15K J 1/10W		
R19			RK73FB2A104J	CHIP R 100K J 1/10W		
R20			RK73FB2A333J	CHIP R 33K J 1/10W		
R21			RK73FB2A104J	CHIP R 100K J 1/10W		
R22			RK73FB2A105J	CHIP R 1.0M J 1/10W		
R23			RK73FB2A103J	CHIP R 10K J 1/10W		
R24 ,25			RK73FB2A332J	CHIP R 3.3K J 1/10W		
R26			RK73FB2A102J	CHIP R 1.0K J 1/10W	M1T1E1	
R26			RK73FB2A102J	CHIP R 1.0K J 1/10W	M3T3E3	
R26			RK73FB2A102J	CHIP R 1.0K J 1/10W	X1	
R27			RK73FB2A105J	CHIP R 1.0M J 1/10W		
R29			RK73FB2A154J	CHIP R 150K J 1/10W		
R30			RK73FB2A104J	CHIP R 100K J 1/10W		
R31			RK73FB2A102J	CHIP R 1.0K J 1/10W		
R32 ,33			RK73FB2A472J	CHIP R 4.7K J 1/10W		
R34			RK73FB2A104J	CHIP R 100K J 1/10W		
R38			RK73FB2A200J	CHIP R 20 J 1/10W		
R39 -44			RK73FB2A103J	CHIP R 10K J 1/10W		
R45 ,46			RK73FB2A432J	CHIP R 4.3K J 1/10W		
R47 ,48			RK73FB2A103J	CHIP R 10K J 1/10W		
R49 ,50			RK73FB2A104J	CHIP R 100K J 1/10W		
R51 ,52			RK73FB2A681J	CHIP R 680 J 1/10W		
R53 ,54			RK73FB2A102J	CHIP R 1.0K J 1/10W		
R55 ,56			RK73FB2A223J	CHIP R 22K J 1/10W		
R57 ,58			RK73FB2A331J	CHIP R 330 J 1/10W		
R59			RK73FB2A222J	CHIP R 2.2K J 1/10W		
R60			RK73FB2A361J	CHIP R 360 J 1/10W		
R62			RK73FB2A103J	CHIP R 10K J 1/10W		
R63			RK73FB2A153J	CHIP R 15K J 1/10W		
R64 ,65			RK73FB2A101J	CHIP R 100 J 1/10W		
R66			RK73FB2A103J	CHIP R 10K J 1/10W		
R67 ,68			RK73FB2A472J	CHIP R 4.7K J 1/10W		
R69			RK73FB2A2R2J	CHIP R 2.2 J 1/10W		
R70			RK73FB2A271J	CHIP R 270 J 1/10W		
R71			RK73FB2A164J	CHIP R 160K J 1/10W		
R72			RK73FB2A224J	CHIP R 220K J 1/10W		
R73 -76			RK73FB2A103J	CHIP R 10K J 1/10W		
R77 ,78			RK73FB2A472J	CHIP R 4.7K J 1/10W		
R80			RK73FB2A103J	CHIP R 10K J 1/10W		
R81			RK73FB2A203J	CHIP R 20K J 1/10W	223/J3	
R82			RK73FB2A332J	CHIP R 3.3K J 1/10W		
R83 ,84			RK73FB2A331J	CHIP R 330 J 1/10W		
R85 -88			RK73FB2A104J	CHIP R 100K J 1/10W		
R89			RK73FB2A103J	CHIP R 10K J 1/10W		
R90			RK73FB2A153J	CHIP R 15K J 1/10W		
R91 ,92			RK73FB2A473J	CHIP R 47K J 1/10W		
R93 -95			RK73FB2A103J	CHIP R 10K J 1/10W		
R96 ,97			RK73FB2A202J	CHIP R 2.0K J 1/10W		
R98			RK73FB2A202J	CHIP R 2.0K J 1/10W	223/J3	

L : Scandinavia K : USA P : Canada R : Mexico C : China I : Malaysia
 Y : PX(Far East, Hawaii) T : Europe E : Europe G : Germany V : China (Shanghai)
 Y : AAFES(Europe) X : Australia Q : Russia H : Korea M : Other Areas Δ indicates safety critical components.

* New Parts
 Parts without **Parts No.** are not supplied.
 Les articles non mentionnés dans le **Parts No.** ne sont pas fournis.
 Teile ohne **Parts No.** werden nicht geliefert.

6

Ref. No	Add-ress	New Parts	Parts No.	Description	Desti-nation	Re-marks
R99 ,100			RK73FB2A512J	CHIP R 5.1K J 1/10W	223/J3	
R101			RK73FB2A512J	CHIP R 5.1K J 1/10W		
R102			RK73FB2A103J	CHIP R 10K J 1/10W	223/J3	
R103			RK73FB2A103J	CHIP R 10K J 1/10W		
R104			RK73FB2A103J	CHIP R 10K J 1/10W	223/J3	
R105			RK73FB2A203J	CHIP R 20K J 1/10W	223/J3	
R106			RK73FB2A203J	CHIP R 20K J 1/10W		
R107			RK73FB2A203J	CHIP R 20K J 1/10W	223/J3	
R108			RK73FB2A513J	CHIP R 51K J 1/10W	223/J3	
R109			RK73FB2A513J	CHIP R 51K J 1/10W		
R110			RK73FB2A513J	CHIP R 51K J 1/10W	223/J3	
R111			RK73FB2A473J	CHIP R 47K J 1/10W		
R112			RK73FB2A331J	CHIP R 330 J 1/10W		
R113-116			RK73FB2A473J	CHIP R 47K J 1/10W		
R117 ,118			RK73FB2A472J	CHIP R 4.7K J 1/10W		
R119 ,120			RK73FB2A473J	CHIP R 47K J 1/10W		
R121 ,122			RK73FB2A103J	CHIP R 10K J 1/10W		
R123 ,124			R92-1867-05	METAL 12K F 1/10W		
R125 ,126		*	R92-1876-05	METAL 10K J 1/10W		
R127-129			RK73FB2A103J	CHIP R 10K J 1/10W		
R130 ,131			RK73FB2A473J	CHIP R 47K J 1/10W		
R132			RK73FB2A102J	CHIP R 1.0K J 1/10W		
R133-135			RK73FB2A102J	CHIP R 1.0K J 1/10W		
R136 ,137			RK73FB2A564J	CHIP R 560K J 1/10W		
VR1			R12-3101-05	TRIMMING POT.		
S1			S70-0031-05	TACT SWITCH		
S2 -4			S70-0031-05	TACT SWITCH	K3P3M3	
S2 -4			S70-0031-05	TACT SWITCH	T3E3Y3	
S5			S70-0031-05	TACT SWITCH		
S6			S70-0031-05	TACT SWITCH	K3P3M3	
S6			S70-0031-05	TACT SWITCH	T3E3Y3	
S7 -9			S70-0031-05	TACT SWITCH		
S10			S70-0031-05	TACT SWITCH	K3P3M3	
S10			S70-0031-05	TACT SWITCH	T3E3Y3	
S11 ,12			S70-0031-05	TACT SWITCH		
S13 -16			S70-0031-05	TACT SWITCH	K3P3M3	
S13 -16			S70-0031-05	TACT SWITCH	T3E3Y3	
S17 ,18			S70-0031-05	TACT SWITCH		
S20		*	S62-0070-05	SLIDE SWITCH		
S21		*	S64-0034-05	LEVER SWITCH		
S22			S31-2132-05	SLIDE SWITCH		
Δ S23			S31-2131-05	SLIDE SWITCH (POWER TYPE)	Y1M1	
Δ S23			S31-2131-05	SLIDE SWITCH (POWER TYPE)	Y3M3	
S19			T99-0596-05	ROTARY ENCODER		
D1 -9			HSS104	DIODE		
D1 -9			1SS133	DIODE		
Δ D20			D3SBA20F03	DIODE		
Δ D20			RBV-402LFA	DIODE		
D21			HZS7.5S(B)	ZENER DIODE		
D21			RD7.5JS(B)	ZENER DIODE		
D22			DLM10C	DIODE		
D23			HSS104	DIODE		
D23			1SS133	DIODE		
Δ D24 ,25			S5688B	DIODE		

L : Scandinavia K : USA P : Canada R : Mexico C : China I : Malaysia
 Y : PX(Far East, Hawaii) T : Europe E : Europe G : Germany V : China (Shanghai)
 Y : AAFES(Europe) X : Australia Q : Russia H : Korea M : Other Areas Δ indicates safety critical components.

PARTS LIST

CD-223M/224M/DPF-J3010/J5010

PARTS LIST

* New Parts
Parts without **Parts No.** are not supplied.
Les articles non mentionnés dans le **Parts No.** ne sont pas fournis.
Teile ohne **Parts No.** werden nicht geliefert.

7

Ref. No	Add-ress	New Parts	Parts No.	Description	Desti-nation	Re-marks
Δ D24 ,25			1SR139-400	DIODE		
D26			HZS16N(B2)	ZENER DIODE		
D26			RD16ES(B2)	ZENER DIODE		
D27			HZS20N(B)	ZENER DIODE		
D27			RD20ES(B)	ZENER DIODE		
D28			HZS11N(B2)	ZENER DIODE		
D28			RD11ES(B2)	ZENER DIODE		
D30 -34			HSS104	DIODE		
D30 -34			1SS133	DIODE		
ED1		*	16-MT-63GK	INDICATOR TUBE		
IC1			CXA1571M	IC(CD RF AMP)		
IC2			CXD2587Q	MOS-IC		
IC7			NJM2115M	ANALOGUE IC		
IC8		*	UPD784214GF501	MI-COM IC		
IC9			HM62256BLFP-8T	MEMORY IC		
IC9			W24257S-70LL	MEMORY IC		
IC10			NJM2100M	MEMORY IC		
IC11			TC74HC00AF	IC(2INPUT NAND GATE)		
IC12			TA8409S	MOS-IC		
IC13		*	LB1930M	ANALOGUE IC		
IC14		*	UPD780204-034	MI-COM IC		
IC16			BA5979S	ANALOGUE IC		
Q1			2SA954(L,K)	TRANSISTOR		
Q9			DTC124ESA	DIGITAL TRANSISTOR		
Q9			UN4212	DIGITAL TRANSISTOR		
Q11 ,12			2SA1048(Y,GR)	TRANSISTOR		
Q11 ,12			2SA1309A(Q,R)	TRANSISTOR		
Q13 ,14			2SD1450(S,T)	TRANSISTOR		
Q19			2SK246(Y)	FET		
Δ Q20			2SB1165(R,S)	TRANSISTOR		
Q21			2SC2458(Y,GR)	TRANSISTOR		
Q21			2SC3311A(Q,R)	TRANSISTOR		
Δ Q22			2SA954(L,K)	TRANSISTOR		
Δ Q25			2SB11417(P)	TRANSISTOR		
Δ Q25			2SB1640	TRANSISTOR		
Δ Q26			2SC2003(L,K)	TRANSISTOR		
Q27			DTA113ZSA	DIGITAL TRANSISTOR		
Q27			UN4119	DIGITAL TRANSISTOR		
Q28			DTA124EUA	DIGITAL TRANSISTOR		
Q28			UN5112	DIGITAL TRANSISTOR		
Q29			DTC124EUA	DIGITAL TRANSISTOR		
Q29			UN5212	DIGITAL TRANSISTOR		
A1			W02-2561-05	ELECTRIC CIRCUIT MODULE	K1P1M1	
A1			W02-2561-05	ELECTRIC CIRCUIT MODULE	T1E1Y1	
A1			W02-2561-05	ELECTRIC CIRCUIT MODULE	X1	
A2			W02-1114-05	OSCILLATING MODULE	M1T1E1	
A2			W02-1114-05	OSCILLATING MODULE	M3T3E3	
A2			W02-1114-05	OSCILLATING MODULE	X1	
MECHANISM CHANGER (MG-CH1)						
1	1E	*	A11-1134-08	BASE ARM		
2	1E	*	D10-3788-08	LEVER R		
3	1D	*	D12-0158-08	CAM CHANGE		
4	1E	*	J19-5892-08	HOLDER ARM		
5	1E	*	G16-0912-08	RUBBER		

L : Scandinavia K : USA P : Canada R : Mexico C : China I : Malaysia
Y : PX(Far East, Hawaii) T : Europe E : Europe G : Germany V : China (Shanghai)
Y : AAFES(Europe) X : Australia Q : Russia H : Korea M : Other Areas Δ indicates safety critical components.

* New Parts
Parts without **Parts No.** are not supplied.
Les articles non mentionnés dans le **Parts No.** ne sont pas fournis.
Teile ohne **Parts No.** werden nicht geliefert.

8

Ref. No	Add-ress	New Parts	Parts No.	Description	Desti-nation	Re-marks
6	1E	*	D10-3778-08	ARM DISC		
7	1E	*	G01-4060-08	SPG DISC H		
8	1E	*	J21-6576-08	PLATE ARM		
9	1D	*	D10-3785-08	SLIDER RACK		
10	1E	*	J19-5891-08	HOLDER RACK		
12	1D	*	D10-3787-08	LEVER CHANGE		
14	1E,2D	*	T42-0920-08	MOTOR		
17	1D	*	D13-1856-08	GEAR D		
19	1D	*	D10-3781-08	LEVER HOOK A		
20	1E	*	D10-3782-08	LEVER HOOK B		
21	1D	*	D13-1857-08	GEAR E		
22	1D	*	S64-0038-08	LEVER SW		
24	1D	*	G01-4066-08	SPG LIMITER		
25	1D	*	J21-6579-08	PLATE LIMITER		
26	1D	*	D10-3779-08	ARM SWING		
27	2D	*	D13-1855-08	GEAR CAM		
28	2D	*	G01-4067-08	SPG CHASSIS SUB		
29	2D	*	J21-6573-08	PLATE LOCK		
30	2D	*	G01-4061-08	SPG LOCK LEVER		
31	2D	*	D10-3780-08	SLIDER CAM		
32	2D	*	J21-6574-08	PLATE SLIDE		
33	2D	*	D13-1854-08	GEAR SLIDER		
Q4	2D	*	D10-3786-08	LEVER STOPPER		
37	2D	*	J90-0854-08	GUIDE RACK		
38	1D	*	G01-4064-08	SPG CHANGE		
39	2D	*	D21-1899-08	PIN ROLLER		
40	2D	*	D14-0393-08	HOLDER ROLLER		
41	2D	*	J19-5888-08	ROLLER GUIDE		
42	2D	*	D21-1900-08	SHAFT MAIN		
43	2D	*	J19-5890-08	HOLDER SHAFT		
44	2D	*	J90-0856-08	GUIDE DISC		
45	1D	*	D32-0354-08	STOPPER DISC		
46	1D	*	J19-5893-08	HOLDER SENSOR		
47	1D	*	J19-5927-08	HOLDER SENSOR		
49	1E	*	J21-6570-08	PLATE HOLD T		
55	2E	*	J21-6580-08	PLATE LINK		
58	2E	*	J21-6571-08	PLATE SLIDER A		
60	2E	*	J21-6575-08	PLATE SUPPORT B		
62	2D	*	D13-1852-08	GEAR B		
63	2D	*	D13-1853-08	GEAR C		
64	1E	*	J90-0855-08	GUIDE DISC U		
65	2E	*	J19-5894-08	HOLDER DISC U		
67	2E	*	G01-4057-08	SPG SLIDER		
68	2E	*	G01-4058-08	SPG HOLD MAGNET		
69	1E	*	G01-4062-08	SPG DAMPER A		
70	1E	*	G01-4063-08	SPG DAMPER B		
71	1E	*	G01-4059-08	SPG PLATE ARM		
72	2D	*	G01-4065-08	SPG STOPPER		
73	1C	*	J19-5889-08	STOCKER ROTARY		
80	2E	*	J11-0827-08	CLAMPER		
82	2E	*	J02-1412-08	INSULATOR		
83	1D	*	E40-8285-08	CONNECTOR 5P		
86	2E	*	T99-0565-05	MAGNET		
87	1D	*	N29-0287-08	E-RING 6.0		
88	1D	*	N19-1458-08	PSW 8.5X16X0.5		

L : Scandinavia K : USA P : Canada R : Mexico C : China I : Malaysia
Y : PX(Far East, Hawaii) T : Europe E : Europe G : Germany V : China (Shanghai)
Y : AAFES(Europe) X : Australia Q : Russia H : Korea M : Other Areas Δ indicates safety critical components.

* New Parts
 Parts without **Parts No.** are not supplied.
 Les articles non mentionnés dans le **Parts No.** ne sont pas fournis.
 Teile ohne **Parts No.** werden nicht geliefert.

5

Ref. No	Add-ress	New Parts	Parts No.	Description	Desti-nation	Re-marks
89	1D	*	N19-1460-08	PSW 8.5X30X0.5		
90	2E	*	J69-0083-04	DOUBLE COATED TAPE		
91	2E	*	T95-0160-08	PHOTO INTERRUPTER		
92	2E	*	E40-8284-08	CONNECTOR 5P		
94	1E,2E	*	N19-1461-08	FLAT WASHER		
LED		*	SIM-20ST	LED		
TR			RPM-20PB	TRANSISTOR		
R			RK73FB2A471J	CHIP R 470 J 1/10W		
MECHANISM ASSY (D40-1515-05)						
3	2A		D10-3606-08	ROD		
4	1B		D13-1720-08	GEAR		
6	3B		S74-0038-08	LEAF SWITCH		
8	3B		E40-3264-05	PIN ASSY		
DM	1B		A11-1082-18	SUB CHASSIS ASSY		
FM	2B		T42-0817-08	MOTOR ASSY		
PU	1A	*	T25-0055-08	OPTICAL PICKUP HEAD		

L: Scandinavia K: USA P: Canada R: Mexico C: China I: Malaysia
 Y: PX(Far East, Hawaii) T: Europe E: Europe G: Germany V: China (Shanghai)
 Y: AAFES(Europe) X: Australia Q: Russia H: Korea M: Other Areas Δ indicates safety critical components.

The method that parts list Description is read.
 The model and Destination that you repair by the following table are able to judge.

Model name	Description							
	Common	K	P	Y	M	X	T	E
CD-223M	3	K3	P3	-	-	-	-	-
DPF-J3010		-	-	Y3	M3	-	T3	E3
CD-224M	1	K1	P1	-	-	-	-	-
DPF-J5010		-	-	Y1	M1	X1	T1	E1

CD-223M and CD-224M are the models name to sell in North America.
 DPF-J3010 and DPF-J5010 are the models name to sell except above country.

CD-223M/224M/DPF-J3010/J5010
 PARTS LIST

CD-223M/224M/DPF-J3010/J5010

SPECIFICATIONS

CD-224M/DPF-J5010

[Format]

System Compact disc digital audio system
Laser Semiconductor laser

[D/A Convertors]

D/A Conversion 1 Bit
Oversampling 8 fs (352.8 kHz)

[Audio]

Frequency response 4 Hz ~ 20 kHz, ± 0.5 dB
Signal to noise ration More than 98 dB
Dynamic range More than 96 dB
Total harmonic distortion + noise
..... Less than 0.004% (at 1 kHz)
Channel separation More than 92 dB (at 1 kHz)
Wow & flutter Unmeasurable Limit
Output level / impedance
Fixed 2.0 V / 1 k Ω
Digital output (DPF-J5010 only)
Optical -15 dBm ~ -21 dB
(Wave length 660 nm)

[General]

Power consumption 10 W
Dimension W : 440 mm (17-5/16")
H : 173 mm (6-13/16")
D : 479 mm (18-7/8")
Weight (Net) 7.4 kg (16.3 lb)

CD-223M/DPF-J3010

[Format]

System Compact disc digital audio system
Laser Semiconductor laser

[D/A Convertors]

D/A Conversion 1 Bit
Oversampling 8 fs (352.8 kHz)

[Audio]

Frequency response 4 Hz~20 kHz, ± 0.5 dB
Signal to noise ratio More than 98 dB
Dynamic range More than 96 dB
Total harmonic distortion + noise
..... Less than 0.004% (at 1 kHz)
Channel separation More than 92 dB (at 1 kHz)
Wow & flutter Unmeasurable Limit
Output level / impedance
Fixed 2.0 V / 1 k Ω
Digital output (DPF-J3010 only)
Optical -15 dBm ~ -21 dBm
(Wave length 660 nm)

[General]

Power consumption 10 W
Dimensions W : 440 mm (17-5/16")
H : 173 mm (6-13/16")
D : 479 mm (18-7/8")
Weight (Net) 7.4 kg (16.3 lb)



1. KENWOOD follows a policy of continuous advancements in development. For this reason specifications may be changed without notice.
2. Sufficient performance may not be exhibited at extremely cold locations (where water freezes.).

Note:

Component and circuitry are subject to modification to insure best operation under differing local conditions. This manual is based on the General market(M) standard, and provides information on regional circuit modification through use of alternate schematic diagrams, and information on regional component variations through use of parts list.

KENWOOD CORPORATION

14-6,Dogenzaka 1-chome, Shibuya-ku, Tokyo, 150 Japan

KENWOOD SERVICE CORPORATION

P.O BOX 22745, 2201 East Dominguez St., Long Beach, CA 90801-5745, U.S.A.

KENWOOD ELECTRONICS CANADA INC.

6070 Kestrel Road, Mississauga, Ontario, Canada L5T 1S8

KENWOOD ELECTRONICS LATIN AMERICA S.A.

P.O BOX 55-2791, Piso 6 plaza Chase, Cl. 47 y Aquilino de la Guardia Panama, Republic de Panama

KENWOOD ELECTRONICS U.K. LIMITED

KENWOOD House, Dwight Road, Watford, Herts., WD1 8EB., United Kingdom

KENWOOD ELECTRONICS BENELUX N.V.

Meachelsesteenweg 418, B-1930 Zaventem, Belgium

KENWOOD ELECTRONICS DEUTSCHLAND GMBH

Rembrücker Str. 15, 63150 Heusenstamm, Germany

KENWOOD ELECTRONICS FRANCE S.A.

13 Boulevard Ney, 75018 Paris, France

KENWOOD ELECTRONICS ITALIA S.p.A.

Via G. Sirtori, 7/9 20129, Milano, Italy

KENWOOD IBÉRICA S.A.

Bolivia, 239-08020 Barcelona, Spain

KENWOOD ELECTRONICS AUSTRALIA PTY. LTD.

(A.C.N. 001499 074)

P.O Box 504, 8 Figtree Drive, Australia Centre, Homebush, N.S.W. 2140, Australia

KENWOOD & LEE ELECTRONICS, LTD.

Unit 3712-3724, Level 37, Tower 1, Metroplaza, 223 Hing Fong Road, Kwai Fong N.T., Hong Kong

KENWOOD ELECTRONICS GULF FZE

P.O.Box 61318, Jebel Ali, Dubai, U.A.E.

KENWOOD ELECTRONICS SINGAPORE PTE LTD.

No. 1 Genting Lane #02-02, KENWOOD Building, Singapore, 349544

KENWOOD ELECTRONICS (MALAYSIA) SDN BHD.

#4.01 Level 4, Wisma Academy Lot 4A, Jalan 19/1 46300 Petaling Jaya Selangor Darul Ehsan Malaysia

KENWOOD ELECTRONICS (THAILAND) CO., LTD.

573/111 Soi Ramkhamhaeng 39, Ramkhamhaeng Road, Wangthonglang, Bangkok, Bangkok 10301 Thailand