

# SEARS

## OWNERS MANUAL

Model No.  
171.240300

# CRAFTSMAN®

Attaches to most table  
saw miter gauges.

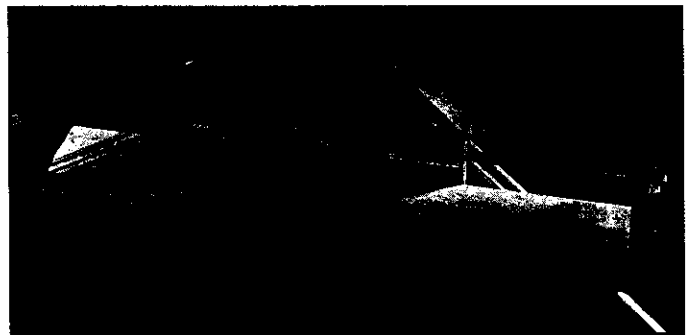
## TABLE SAW BOX JOINT AND MITER GUIDE

SAFETY

ASSEMBLY

OPERATION

PARTS LIST



### **WARNING:**

Before operating  
product, read this  
manual and follow  
all its Safety  
and Operating  
Instructions.

Sears, Roebuck and Co.. Hoffman Estates IL 60179 USA

171.240300 05/98 Printed in U.S.A.

## TABLE OF CONTENTS

<b>General Safety Instructions for Power Tools.....</b>	<b>3</b>
<b>Additional Safety Instructions for Box Joint Templates.....</b>	<b>4</b>
<b>Optional Table Saw Accessories.....</b>	<b>5</b>
<b>Unpacking and Checking Contents .....</b>	<b>5</b>
<b>Assembly .....</b>	<b>6</b>
<b>Operation.....</b>	<b>9</b>
<b>Helpful Hints.....</b>	<b>15</b>
<b>Parts List.....</b>	<b>17</b>

## SAFETY GUIDELINES – DEFINITIONS

This manual contains information that is important for you to know and understand. This information relates to protecting **YOUR SAFETY** and **PREVENTING EQUIPMENT PROBLEM**. To help you recognize this information, we use symbols to the right. Please read the manual and pay attention to these sections.



**URGENT SAFETY INFORMATION -  
A HAZARD THAT WILL CAUSE  
SERIOUS INJURY OR LOSS OF LIFE**



**INFORMATION FOR PREVENTING  
DAMAGE TO EQUIPMENT**



**IMPORTANT SAFETY INFORMATION -  
A HAZARD THAT MIGHT CAUSE  
SERIOUS INJURY OR LOSS OF LIFE**

**NOTE**

**INFORMATION THAT YOU SHOULD  
PAY SPECIAL ATTENTION TO**

## GENERAL SAFETY INSTRUCTIONS FOR POWER TOOLS



Failure to heed all safety and operating instructions and warnings regarding use of this product can result in serious bodily injury.

### 1. Know your power tool

Read the owner's manual carefully. Learn its application and limitations as well as the specific potential hazards peculiar to this tool.

### 2. Ground all tools (unless double insulated)

If tool is equipped with an approved three-conductor cord and a three-prong grounding type plug, it should be plugged into a three hole electrical receptacle. If adapter is used to accommodate a two-prong receptacle, the adapter wire must be attached to known ground, (usually the screw securing receptacle cover plate). Never remove third prong. Never connect green ground wire to a terminal.

### 3. Keep guards in place

Maintain in working order, and in proper adjustment and alignment.

### 4. Remove adjusting keys and wrenches

Form a habit of checking to see that keys and adjusting wrenches are removed from tool before turning it on.

### 5. Keep work area clean

Cluttered areas and benches invite accidents. Floor must not be slippery due to wax or sawdust.

### 6. Avoid dangerous environment

Do not use power tools in damp or wet locations or expose them to rain. Keep work area well lighted. Provide adequate surrounding work space.

### 7. Keep children away

All visitors should be kept a safe distance from work area.

### 8. Make workshop child-proof

Use padlocks, master switches, or remove starter keys.

### 9. Do not force tools

It will do the job better and safer at the rate for which it was designed.

### 10. Use the right tool

Do not force tool or attachment to do a job it was not designed to perform.

### 11. Wear right apparel

Do not wear loose clothing, gloves, neckties or jewelry (rings, wristwatches) that may get caught in moving parts. Non-slip footwear is recommended. Wear protective hair covering to contain long hair. Roll long sleeves above the elbow.

### 12. Use safety goggles (Head Protection)

Wear Safety goggles (must comply with ANSI Standard Z87.1) at all times. Also, use face or dust mask, if cutting operation is dusty, and ear protectors (plugs or muffs) during extended periods of operation.

### 13. Secure work

Use clamps or a vise to hold work when practical. It's safer than using your hands, and it frees both hands to operate tool.

### 14. Do not overreach

Keep proper footing and balance at all times.

### 15. Maintain tools with care

Keep tools sharp and clean for best and safest performance. Follow instructions for lubricating and changing accessories.

#### 16. Disconnect tools

Before servicing, when changing accessories such as blades, bits, cutters, etc.

#### 17. Avoid accidental starting

Make sure switch is in "OFF" position before plugging in.

#### 18. Use recommended accessories

Consult the owner's manual for recommended accessories and follow the instructions. The use of improper accessories may cause hazards.

#### 19. Never stand on tool

Serious injury could occur if the tool is tipped or if the cutting tool is accidentally contacted. Do not store materials above or near the tool making it necessary to stand on the tool to reach them.

#### 20. Check damaged parts

Before further use of the tool, any guard or other part that is damaged should be carefully checked to ensure that it will operate properly and perform its intended function. Check for alignment of moving parts, binding of moving parts, breakage of parts, mounting, and any other conditions that may affect its operation. A guard or any other part that is damaged should be properly repaired or replaced.

#### 21. Direction of feed

Feed work into a blade or cutter only against the direction of rotation of the blade or cutter.

#### 22. Never leave tool running unattended

Turn power off. Do not leave tool until it comes to a complete stop.

#### 23. Keep hands away from cutting area

#### 24. Store idle tools

When not in use, tools should be stored in dry, high or locked-up place – out of reach of children.

#### 25. Do not abuse cord

Keep cord away from heat, oil and sharp edges.

#### 26. Outdoor extension cords

When tool is used outdoors, use only extension cords suitable for use outdoors and so marked.

#### 27. Never use in an explosive atmosphere

Normal sparking of the motor could ignite fumes, flammable liquids, or combustible items.

#### 28. Drugs, alcohol, medication

Do not operate tool while under the influence of drugs, alcohol, or any medication.

Read and Understand this instruction book completely **BEFORE** using this product.

### ADDITIONAL SAFETY INSTRUCTIONS FOR TABLE SAW BOX JOINT AND MITER GUIDE

1. Always wear eye protection that complies with current ANSI Standard Z87.1.
2. Noise levels vary widely. To avoid possible hearing damage, wear ear plugs or muffs when using the Table Saw Box Joint and Miter Guide.
3. Wear a dust mask along with the safety goggles.
4. Follow the instructions in your table saw owner's manual.
5. Do not use this product until all assembly installation steps have been completed, and you have read and understand all safety and operational instructions in this manual.
6. This product is designed to cut flat workpieces. **Do not cut or attempt to cut workpieces that are not flat or that are irregularly shaped.**
7. This product is to be used for cutting wood workpieces only. **Do not use this product to cut metal.**

#### **WARNING**

- Always UNPLUG the table saw from the electrical outlet:
- before installing or removing saw blades from the table saw
  - when adjusting the cutting depth or width of the saw blade or dado blade
  - when changing the setup of the Box Joint and miter guide.
8. Making box joint cuts requires the unit to pass over the saw blade. Remember to keep your hands away from the cutting area.
  9. When setting up to make test cuts using the box joint unit, confirm that the saw blade or dado blade does not contact the fixture.
  10. Confirm that all fasteners remain tight and secure through all operations.

## OPTIONAL TABLE SAW ACCESSORIES

### 9-32040 Craftsman Storage Basket Set

Keeps accessories, fence (when not being used), table saw insert plates, project pieces handy and ready for use. Two 8 3/4" x 36" baskets; one open end, one closed end. Mount to Craftsman table saws, radial saws and band saws.

### 9-3214, 9-3217, 9-3218 Craftsman Molding Heads and Molding Sets

Turn your table saw into a shaper with one of the unique Craftsman molding head sets. Make decorative edges, woodworking joints, and fancy trim with a Craftsman molding head cutter bits.

### 9-3233 Craftsman Taper Jig

Tapers to 3 in/ft or 15°. Handy reference scale in degrees of taper. Has locking bracket and positive push heal. May be reassembled for use on either side of table saw fence.

### 9-32190 Craftsman Table Saw Guide Master

Multipurpose push shoe helps in table saw blade setup for angle settings. Used for ripping operations; has high handle that helps keep hands away from saw blade. Long front of table saw Guide Master keeps pressure down on top of board, eliminating chatter. Includes gauges for 22 1/2°, 45°, and 90° angles and two measuring scales for easy reference. Accurate blade height indicator steps in 1/16" increments. Finds the center for both round and square pieces.

### 9-32371 Craftsman Table Saw Fence Guide System

Designed for use with most table saws. The Fence Guide System is designed for ripping operations sliding over the rip fence and guiding the stock through the blade. The unit will adjust to a maximum fence width of 2 1/2" in width and 3 1/8" in height. Built-in setup checks blade for squareness, 45° angle setting and depth of cut scale for blade and dado height/depth. Adjustable clamping features aid in cutting tenons and sawing spine cut for miter joints.

### Craftsman Saw Blades and Dado Heads

There is a blade and dado almost any need. Craftsman Steel, Carbide, Industrial, and Excalibur blades and dados are manufactured for the weekend user or the professional woodworker/contractor.

## UNPACKING AND CHECKING CONTENTS

Refer to Parts List on page 17



**WARNING** If **ANY** of the parts are missing, or cannot be accounted for, **DO NOT** attempt to assemble, install, or use the Table Saw Box Joint and Miter Guide until the missing parts have been obtained and the product has been assembled properly.

- Contact your local Sears Retail Outlet, or Service Center, for a replacement product, or for the missing parts.

- In order to simplify handling, and to minimize any damage that may occur during shipping, your Table Saw Box Joint and Miter Guide are packaged unassembled.
- Separate all parts from the packaging materials and check each part against the illustrations and the Parts List at the end of this manual, to make sure that all parts are accounted for. Do this before discarding any of the packaging material.

# ASSEMBLY

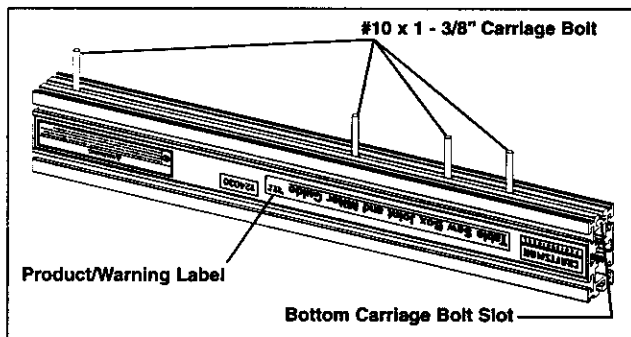
## TOOLS INCLUDED

- Mini-driver, 3/8" nut driver and P2 Phillips insert bit

## SEE PARTS LIST FOR EXPLODED VIEW OF TABLE SAW BOX JOINT AND MITER GUIDE

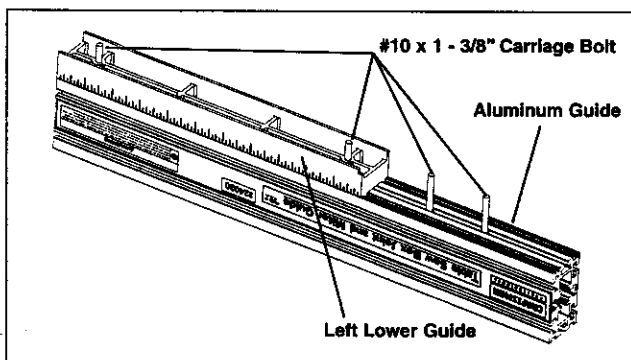
1. Carefully unpack components from carton and confirm that all parts have been shipped with the product (refer to the parts list on page 15 of instruction manual to identify the components).
2. Locate the main guide and slide four (4) of the #10x1 3/8" carriage bolts into the carriage bolt slot and space apart as shown in Fig. 1.

FIGURE 1



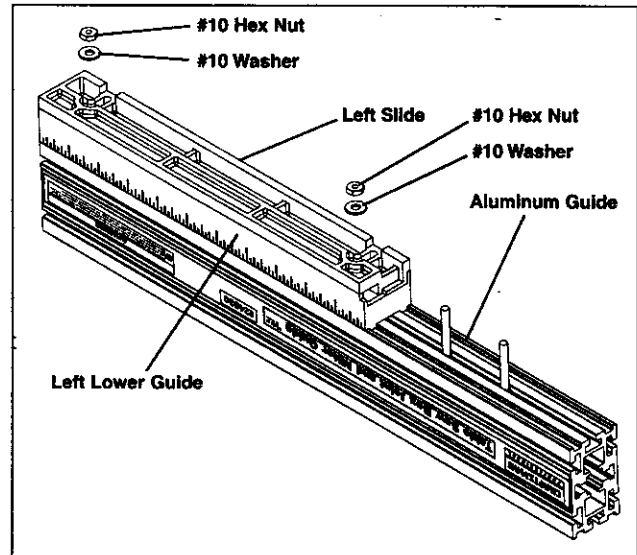
3. Place the left lower guide over two (2) of the carriage bolts as shown in Fig. 2. Confirm that the hash marks on the lower left guide and the product/warning label are facing in the same direction as shown in Fig. 2.

FIGURE 2



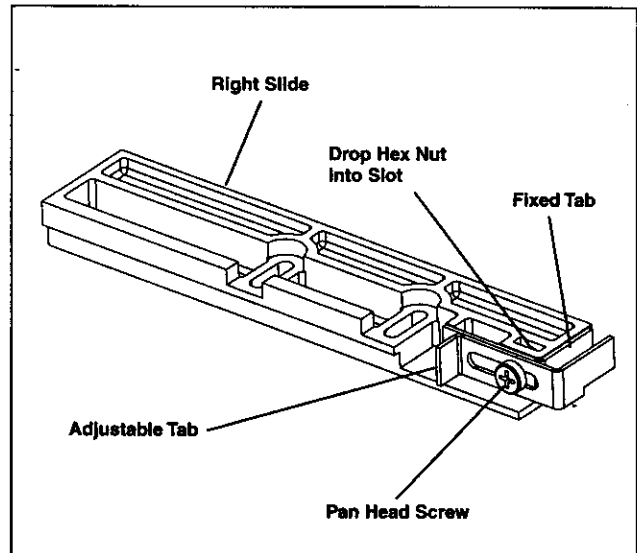
4. Assemble the left slide piece to the left lower guide as shown in Fig. 3.

FIGURE 3



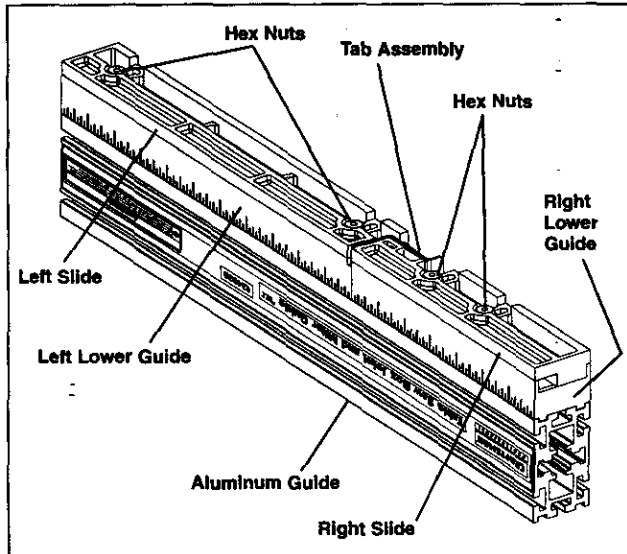
5. Install the #10 washers and hex nuts on the two carriage bolts making sure to thread the hex nuts so the left lower guide and the left slide piece can be adjusted side-to-side during the assembly steps.
6. Attach the fixed tab and adjustable tab to the right slide piece using the #10 hex nut and the #10x3/8" pan head screw. Refer to Fig. 4 for the correct orientation of the tabs and for the placement of the hex nut.

FIGURE 4



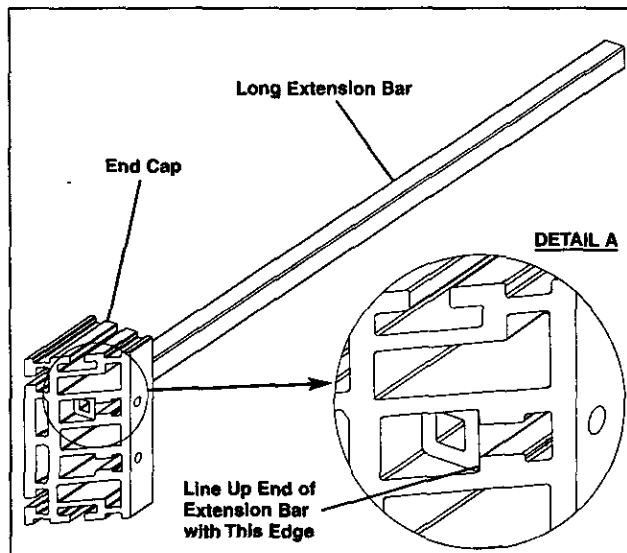
7. Repeat steps 3, 4 and 5 to assemble the right lower guide piece and the right slide piece to the aluminum guide. Refer to Fig. 5 for the finished guide sub-assembly.

**FIGURE 5**

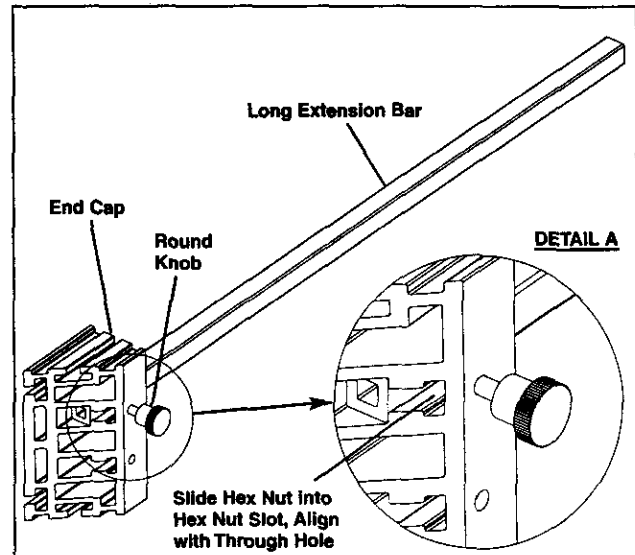


8. Locate one of the two (2) end caps and the long extension bar. Assemble the end cap and the long extension bar as shown in Fig. 6. Slide one (1) hex nut into the hex nut slot on the end cap and thread the round knob through the hole and hex nut as shown in Fig. 7. Make sure to tighten the knob against the extension bar securely.

**FIGURE 6**

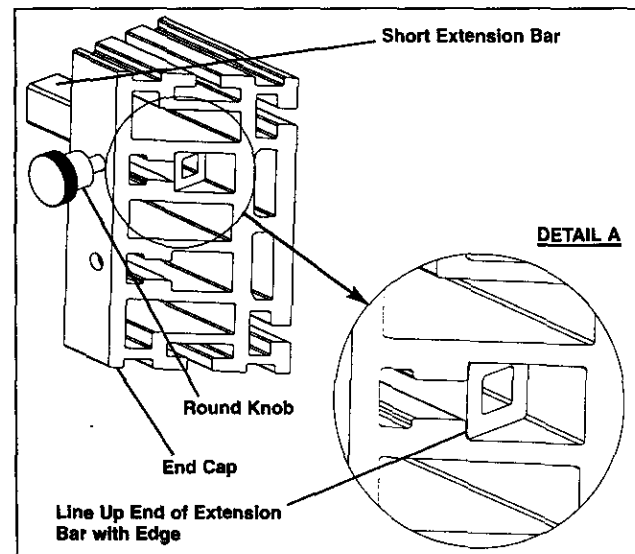


**FIGURE 7**



9. Locate the other end cap and short extension bar and assemble following step 8 and Fig. 8.

**FIGURE 8**

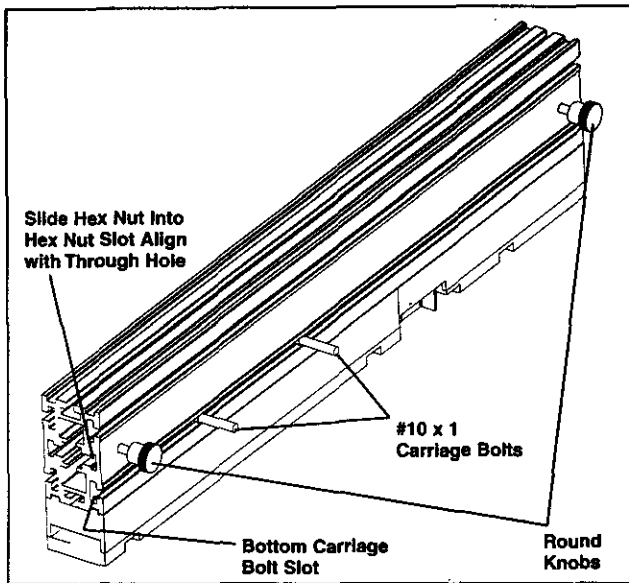


10. Before assembling the two end cap sub-assemblies and the guide sub-assembly complete the following (Refer to Fig. 9 on page 8):

- slide two (2) of the #10x1" carriage bolts into the bottom carriage bolt slot on the back of the aluminum guide. These bolts are for mounting the miter guide to your table saw miter gauge.
- slide two (2) hex nuts into the hex nut slot and align with the through hole on each end of the aluminum guide.
- thread a round knob into each of the hex nuts.

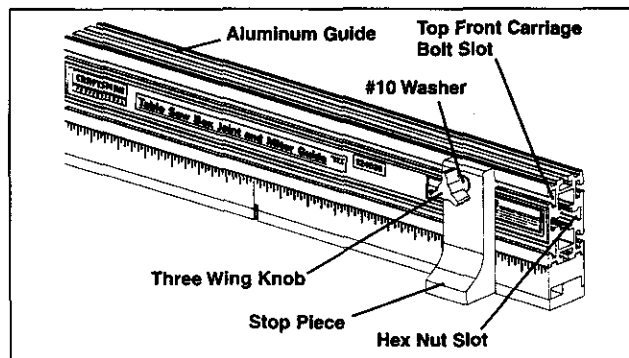
**ASSEMBLY**

**FIGURE 9**

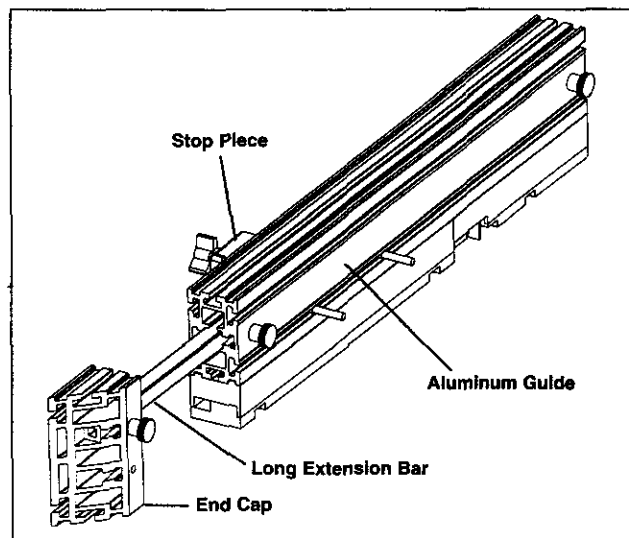


11. Slide one (1) #10x1" carriage bolt into the top carriage bolt slot on the front of the aluminum guide and install the stop piece, #10 washer, and three wing knob as shown in Fig. 10.

**FIGURE 10**



**FIGURE 11**



12. Slide the long extension bar sub-assembly into the aluminum guide as shown in Fig. 11. Slide the bar into the extrusion until the end cap is in contact with the aluminum guide end.

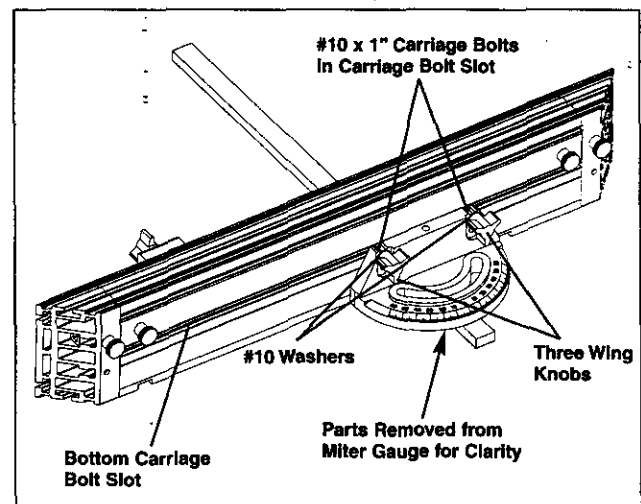
**NOTE**

The end caps and extension bars are interchangeable in either end of the miter bar for use on either side of saw blade. Reorienting extension bar and end caps will be necessary.

13. Repeat step 12 for the short extension bar.

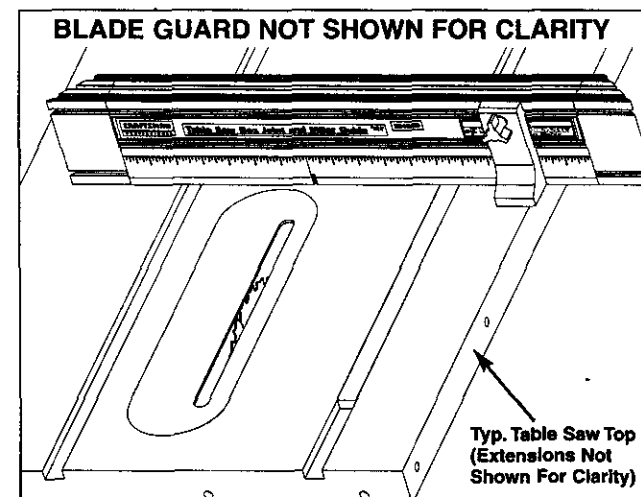
14. Attach the guide to your miter gauge using the two carriage bolts on the back of the aluminum guide, two (2) #10 washers, and two (2) three wing knobs as shown in Fig. 12.

**FIGURE 12**



15. The miter guide should now be fully assembled and be ready for use on your table saw. Refer to Fig. 13 for a fully assembled view.

**FIGURE 13**





# OPERATION

## MITER FENCE USE TIPS

### NOTE

If your table saw is not a Craftsman stationary saw, it may be necessary to attach a secondary mounting piece to the miter gauge in order to mount the miter guide. REFER TO PAGE 15 FOR SPECIAL MOUNTING INFORMATION.

### Common Uses:

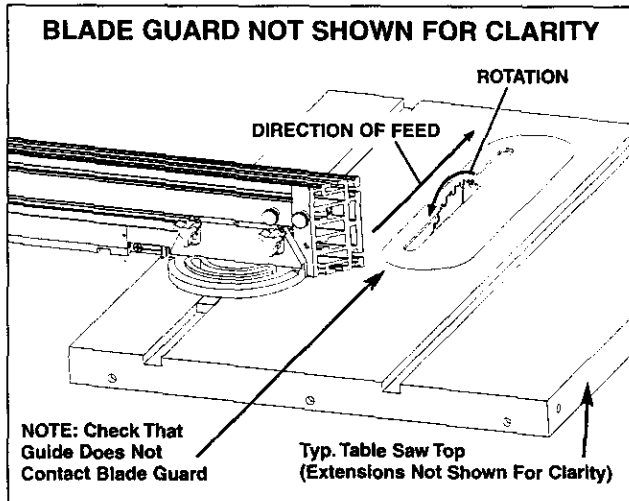
The unit can be used for the following crosscutting operations:

- 90 degree crosscuts
- Miter cuts using the miter gauge
- Compound miter cuts
- Repeatable length crosscuts up to 36"

### CAUTION

When using the miter guide to make crosscut, confirm that the unit does not interfere with the blade guard. When using the left miter slot, adjust the guide so that the end cap can pass by the blade guard. **IT IS NOT RECOMMENDED THAT THE GUIDE RAISE THE BLADE GUARD DURING THE CUTTING OPERATION.** Refer to Fig. 14.

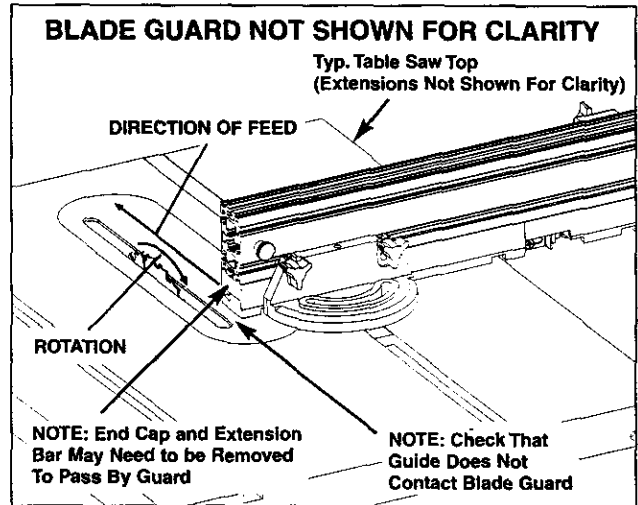
FIGURE 14



### CAUTION

**WHEN USING THE RIGHT MITER SLOT, THE END CAP AND EXTENSION BAR MAY HAVE TO BE REMOVED TO CLEAR THE BLADE GUARD. IT IS NOT RECOMMENDED THAT THE GUIDE RAISE THE BLADE GUARD DURING THE CUTTING OPERATION.** Refer to Fig. 15.

FIGURE 15



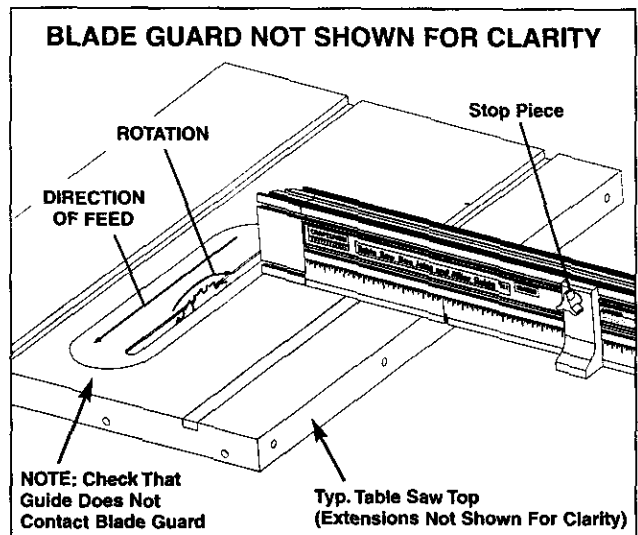
### Repeatable Length Crosscut:

1. When using the miter guide for this operation, adjust the stop piece to obtain the desired workpiece length. Refer to Fig. 16.

### WARNING

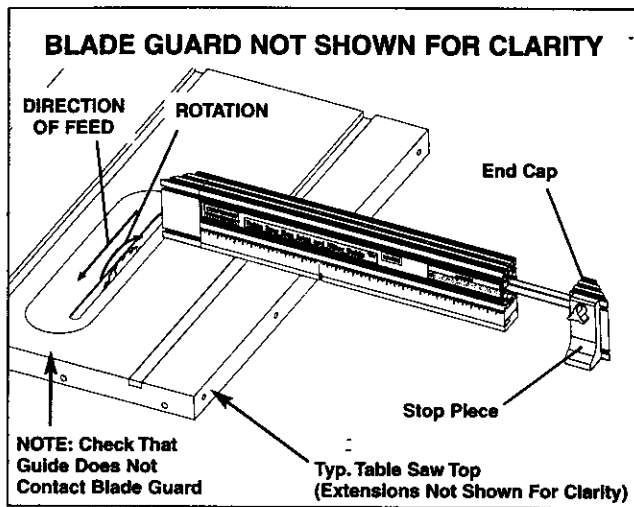
Ensure that the three wing knob on stop piece and two (2) three wing knobs on miter gauge are tight and secure to prevent movement of stop piece and miter guide.

FIGURE 16



2. If the cut length is over 18", move the stop piece onto the end cap and adjust the extension bar to the proper length. Refer to Fig. 17.

FIGURE 17



**NOTE**

If the cut length is longer than 36", the miter guide can still be used to guide the wood; however, the stop piece must be removed from the miter guide.

**BOX JOINT SYSTEM USE TIPS**

Using this unit enables you to make box joints that can be any width from 1/8" up to 13/16" wide. For purpose of the manual, it is assumed that a dado blade set will be used to cut the sockets (female portion of the joint).

**NOTE**

Before starting the following setup steps, determine the width of the fingers/sockets on the box joint for the project.

**Table Saw Setup:**

**NOTE**

Before converting the unit from the Miter Guide setup to the Box Joint setup, the table saw and dado need to be prepared for the box joint cutting operation. The following steps assume that the miter gauge is already attached to the unit. If the gauge is not attached to the unit, refer to page 8, step 14 for proper miter gauge installation.

**WARNING**

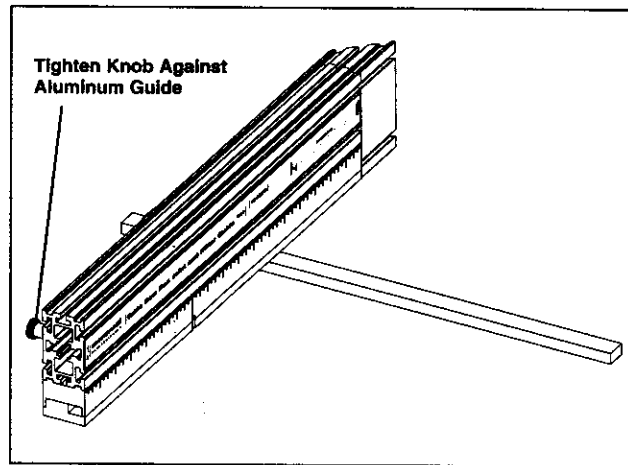
Before performing any of the following setup steps UNPLUG the table saw from the electrical outlet.

1. Referring to the table saw owner's manual, remove the blade guard and spreader.
2. Install the dado on the saw, setup the cutting width, and install the proper table insert for dadoing.

**Conversion from Miter Guide Setup to Box Joint Setup:**

1. Remove the stop piece assembly, the right end cap and the extension bar that is assembled to the right end cap. Tighten the round knob that held the extension bar until the knob is secure against the aluminum guide. Refer to Fig. 18.

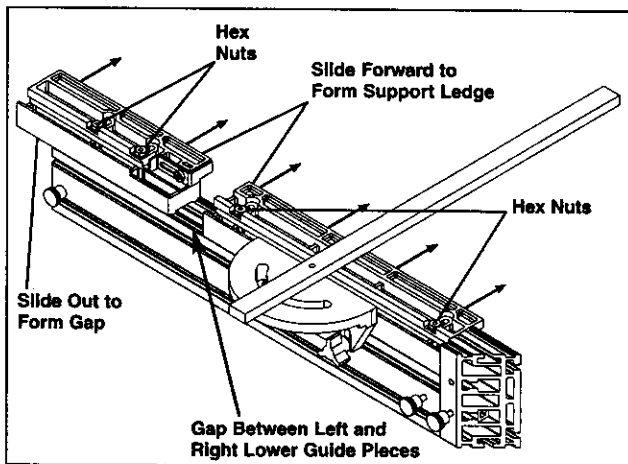
FIGURE 18



2. Flip the miter guide over and loosen the four hex nuts on the right and left slide pieces. Slide the right and left side pieces forward to form a support ledge. Refer to Fig. 19.

3. Slide the right lower guide and right slide assembly away from the left guide assembly to form a large gap between the pieces. Refer to Fig. 19.

FIGURE 19

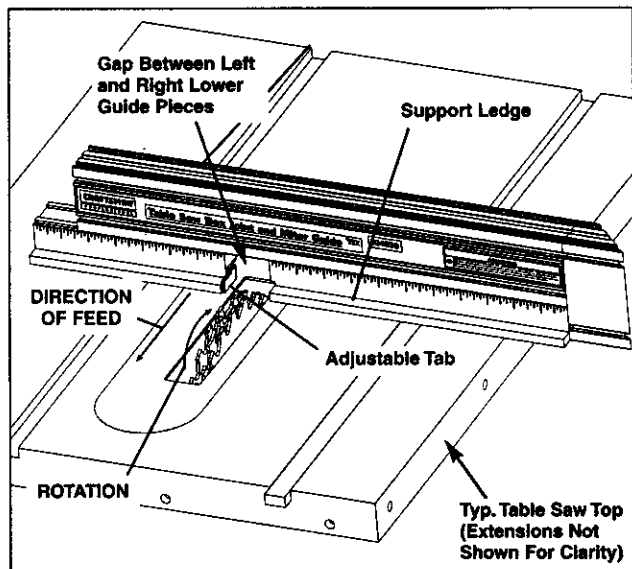


**NOTE**

This gap will allow the unit to pass over the dado during the box joint cutting operations. The gap width needs to be approximately **3 TIMES** the width of the dado. Refer to Fig. 21, "E" Dimension for exact dimension details.

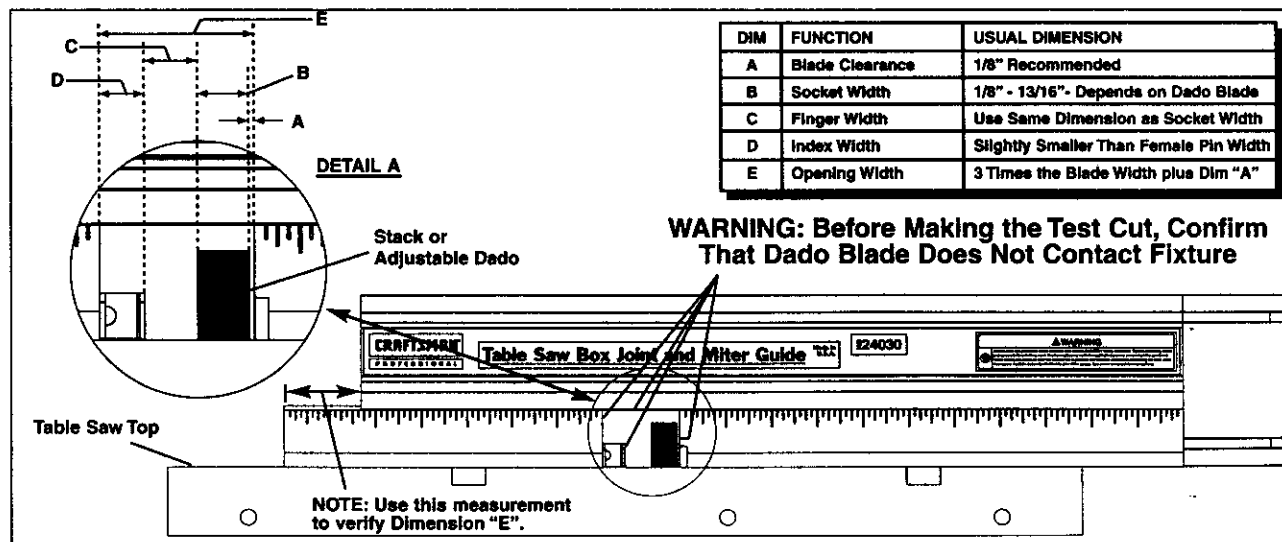
4. Retighten the two (2) hex nuts on the left slide piece. There is no reason to reposition the left guide assembly while using the unit in the Box Joint Setup.
5. Temporarily retighten the two (2) hex nuts on the right guide assembly.
6. Place the unit on the table saw such that the miter gauge is located in the left miter slot.
7. Loosen the two (2) three wing knobs that hold the unit to the miter gauge and reposition the entire unit as shown in Fig. 20.

FIGURE 20



8. Check that the clearance between the dado and the left guide assembly is 1/8". Refer to Fig. 21, "A" Dimension for measurement details.
9. Retighten the two (2) three wing knobs that were loosened in the previous step.

FIGURE 21



10. Confirm that the gap, which was set in step 3, is set correctly by measuring from the end of the aluminum guide to the end of the right guide assembly. Refer to Fig. 21, "E" Dimension for measurement details.
11. Set the cutting height of the dado.

**NOTE** The unit is now ready to make a test cut to check that the previous setup steps have been completed correctly.

**WARNING** THE MAXIMUM CUTTING HEIGHT OF THE DADO WHEN USING THE FIXTURE IS 1 1/8" (MEASURED FROM THE TABLE SAW TOP).

**NOTE** The maximum socket (female portion of the joint) depth and workpiece thickness is 13/16". To determine the depth that the dado will cut a socket, subtract the thickness of the support ledge (5/16") from the cutting height of the dado.

**WARNING** The workpiece must be at least 6 TIMES the width of one finger or socket and be supported at all times to avoid any tipping while cutting the joints. Hold the workpiece securely against the front of the guide and down on top of the support ledge

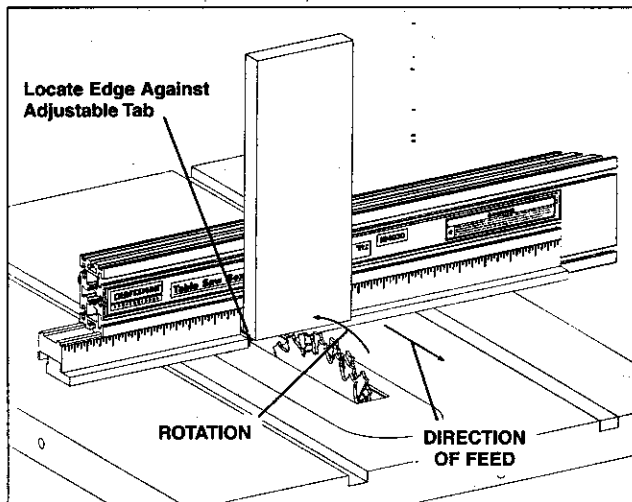
**CAUTION** Before starting the operation confirm that the dado does not come into contact with any part of the fixture.

### Socket Width and Depth Setup:

**WARNING** WORKPIECE MUST BE REMOVED FROM SUPPORT LEDGE AFTER EACH CUT. DO NOT ATTEMPT TO RETURN GUIDE TO STARTING POSITION WITH WORKPIECE ON SUPPORT LEDGE.

12. Using a scrap board, place the board on the unit as shown in Fig. 22. Make a test cut. Check the test cut to confirm that the slot made by the dado is the correct width ("B" Dimension) and depth.

FIGURE 22



### Index Tab (Width) Setup

13. Loosen the pan head screw that holds the fixed and adjustable tabs together so that the adjustable tab can be moved.

14. Position the slot cut in step 12 over the fixed and adjustable tab. Move the adjustable tab until the tabs are snug in the socket ("D" Dimension). Tighten the pan head screw to hold the position of the adjustable tab.

### Finger Width Setup:

15. With the slot from step 12 positioned over the tabs, make a second test cut. Check the distance between the two slots (sockets) to check the finger width ("C" Dimension).

**NOTE** If the finger width ("C" Dimension) is smaller than socket width ("B" Dimension), this will result in a loose fitting box joint. If the finger width ("C" Dimension) is larger than the socket width ("B" Dimension) this will result in a tight fitting box joint or a box joint that will not be able to go together. For adjustment details, see step 16.

16. The finger width ("C" Dimension) is adjusted by moving the entire unit to the left or right. While standing behind the unit, loosen the two (2) three wing knobs holding the unit to the miter gauge and move the unit to the left to decrease the finger width or to the right to increase the finger width.

**NOTE** It should not be necessary to move the unit any more than 1/16" in either direction. If the unit has to be adjusted more than 1/16", "A" Dimension or "E" Dimension was not set correctly in the previous steps.

17. After the unit has been adjusted to the preferred finger width, retighten the two (2) three wing knobs securely.

18. The unit is now ready to cut finished pieces.

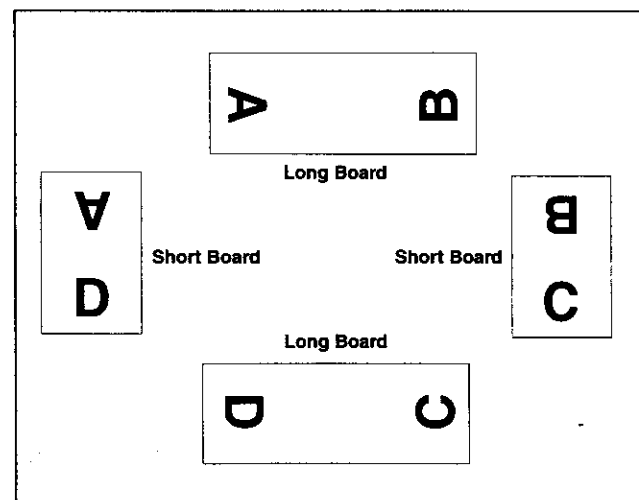
### Finger Joint Cutting Instructions:

**WARNING** This operation requires that the blade guard be removed. Always keep hands and fingers away from the cutting area.

**NOTE** There are a number of ways to make all the necessary cuts so the box joint fingers fit together correctly; for purposes of the instruction manual the example shown will be a rectangular box that has finger joints at every corner.

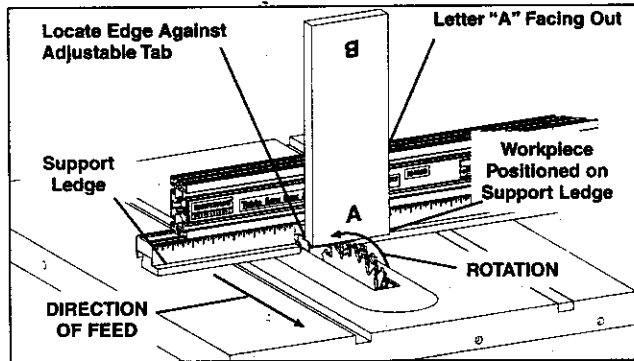
1. Arrange the four boards of the box and letter each corner as shown in Fig. 23A.

FIGURE 23A



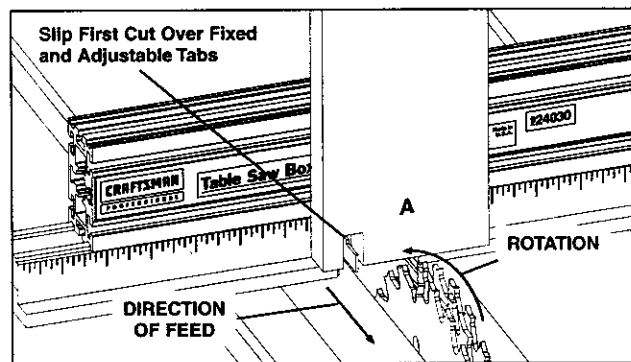
2. Select the long board and short board with the "A" corner. Place the long board on the support ledge as shown in Fig. 23B. Cut the first slot making sure to keep the leading edge of the workpiece against the adjustment tab, against the back of the guide and against the top of the support ledge.

FIGURE 23B



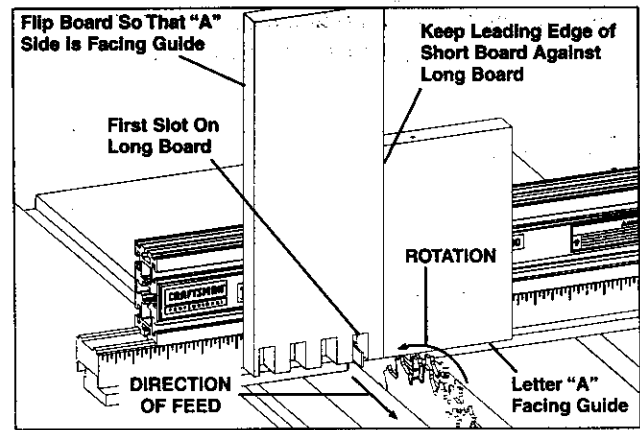
3. Reposition the long board as shown in Fig. 23C so that the slot cut in step 2 is located over the adjustable and fixed tabs. Cut the second slot as in step 2.

FIGURE 23C



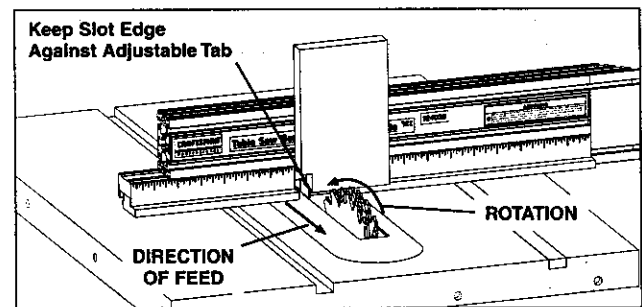
4. Repeat step 3 until the long side is completed.
5. Reorient the long board on the support ledge as shown in Fig. 23D such that the "A" marking is facing towards the guide.
6. Place the short board on the support ledge as shown in Fig. 23D such that the "A" marking is facing towards the guide.

FIGURE 23D



7. While holding both boards firmly in place, cut the first slot. Remove the long board from the unit and reposition the short board as shown in Fig. 23E. Cut the rest of the slots as described in step 3 & 4.

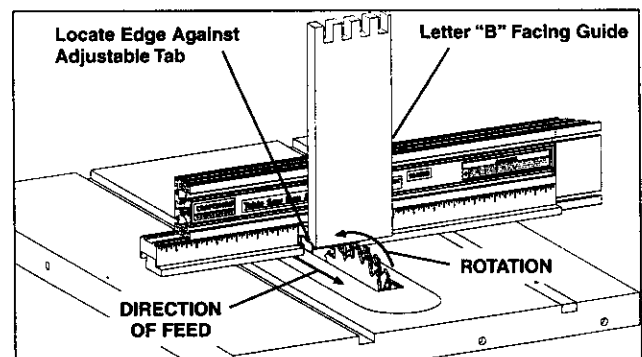
FIGURE 23E



8. Repeat steps 2 - 7 for the "C" corner.

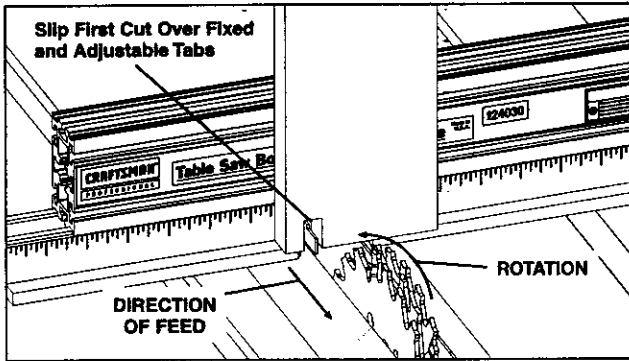
9. Select the long board and short board with the "B" corner. Place the long board on the fixture as shown in Fig. 24A. Cut the first slot making sure to keep the leading edge of the workpiece against the adjustment tab, against the back of the guide and down against the top of the support ledge.

FIGURE 24A



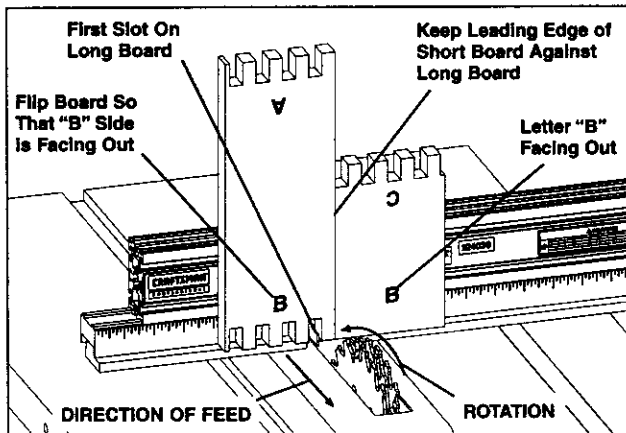
10. Reposition the long board as shown in Fig. 24B so that the slot cut in step 9 is located over the adjustable and fixed tabs. Cut the second slot.

FIGURE 24B



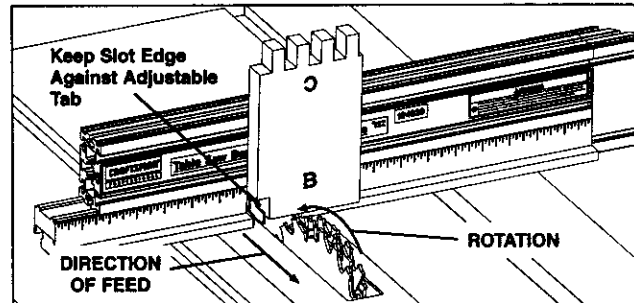
11. Repeat step 10 until the long board is completed.
12. Reorient the long board on the support ledge as shown in Fig. 24C so the "B" marking is facing away from the guide.
13. Place the short board on the support ledge as shown in Fig. 24C so the "B" marking is facing away from the guide.

FIGURE 24C



14. While holding both boards firmly in place, cut the first slot; remove the long board from the unit and reposition the short board as shown in Fig. 24D. Cut the rest of the slots as in steps 10 & 11.

FIGURE 24D



15. Repeat steps 9 - 14 for the "D" corner.
16. All of the corners should be cut and the four sides should be ready to be assembled. Refer to Fig. 25 on page 15 for proper box assembly.

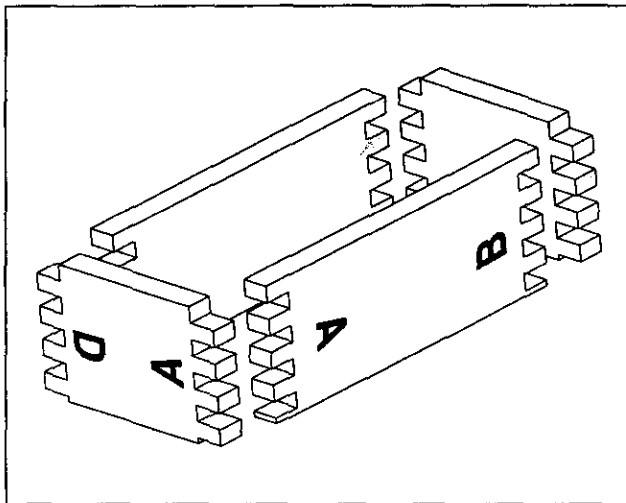
## HELPFUL HINTS

### Box Assembly:

#### NOTE

After all of the corners have been cut, the boards should be able to go together so that all of the letters (A, B, C & D) face in the same direction. The example box is shown with the letters facing the outside, but the box could have been assembled with all of the letters facing inside.

FIGURE 25



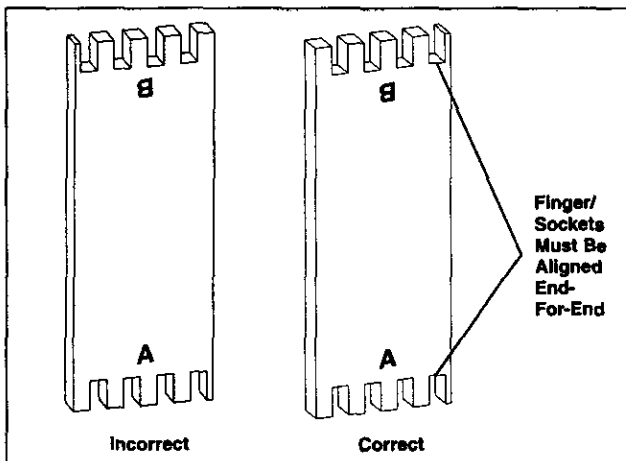
### Correct/Incorrect Finger/Sockets:

Refer to Fig. 26 for the correct finger/socket orientation on each end of the boards.

#### NOTE

If the finger/sockets are not aligned, this would indicate that one of the boards was not placed on the unit in the correct orientation. Refer to steps 1 - 16 on pages 12 - 14 for the correct board orientation.

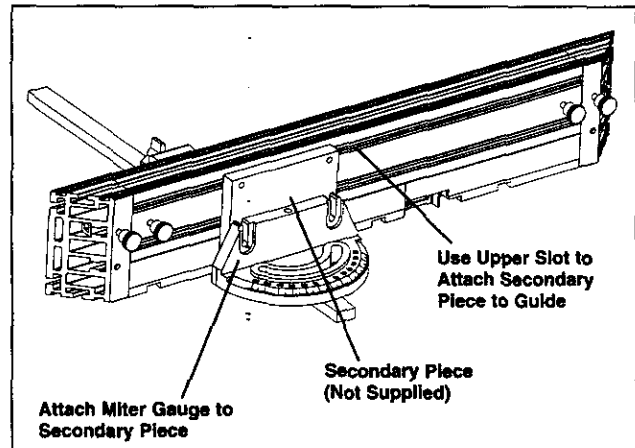
FIGURE 26



### Mounting Guide to Non-Craftsman Miter Gauge:

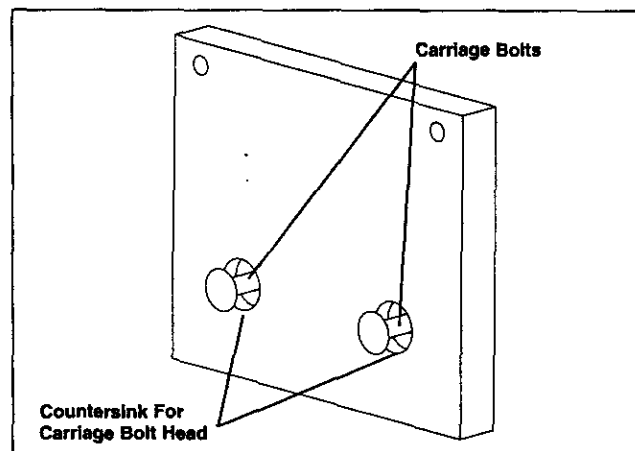
1. If miter gauge is a non-Craftsman gauge, it might be necessary to make a secondary mounting piece to attach the guide to your miter gauge. The aluminum guide has an upper carriage bolt slot which provides a location to mount the secondary piece to the guide. Refer to Fig. 27.

FIGURE 27



2. Use the two (2) #10-1" carriage bolt slots and the two (2) three wing knobs provided to attach the secondary piece to the unit. It is required that the fasteners that attach the secondary piece to the miter gauge be below the front surface of the secondary piece. Refer to Fig. 28 for an example of one method.

FIGURE 28



### Back-Up Board Installation:

#### NOTE

Due to the crosscutting direction, a small amount of chipping may occur to the workpiece when cutting finger joints. To reduce the chipping, a back-up board should be attached to the unit.

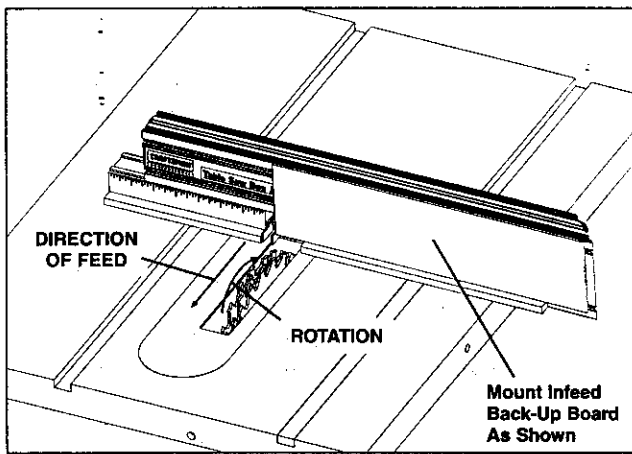
**WARNING**

The thickness of the back-up board cannot exceed 1/8" thickness.

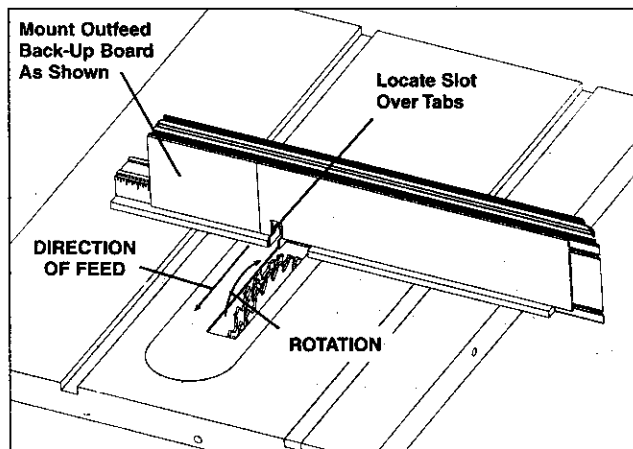
**NOTE**

The back-up board should not be installed on the unit until the box joint setup steps have been completed and you are ready to cut finished boards.

1. Obtain two pieces of suitable material and cut both pieces so that one piece is 13" wide x 3 1/2" tall and the second piece is 5" wide x 3 1/2" tall. Position the long (infeed) back-up board on the unit as shown in Fig. 29 and cut one slot.

**FIGURE 29**

2. Remove the infeed board from the unit and place double-stick tape on the back of the board, being careful to avoid placing the tape where it could contact the product/warning label on the guide.
3. Place the infeed board on the unit as shown in Fig. 30, making sure that the board is attached to the unit securely.
4. Repeat steps 2 and 3 for the short (outfeed) back-up board and locate on the unit as shown in Fig. 30.

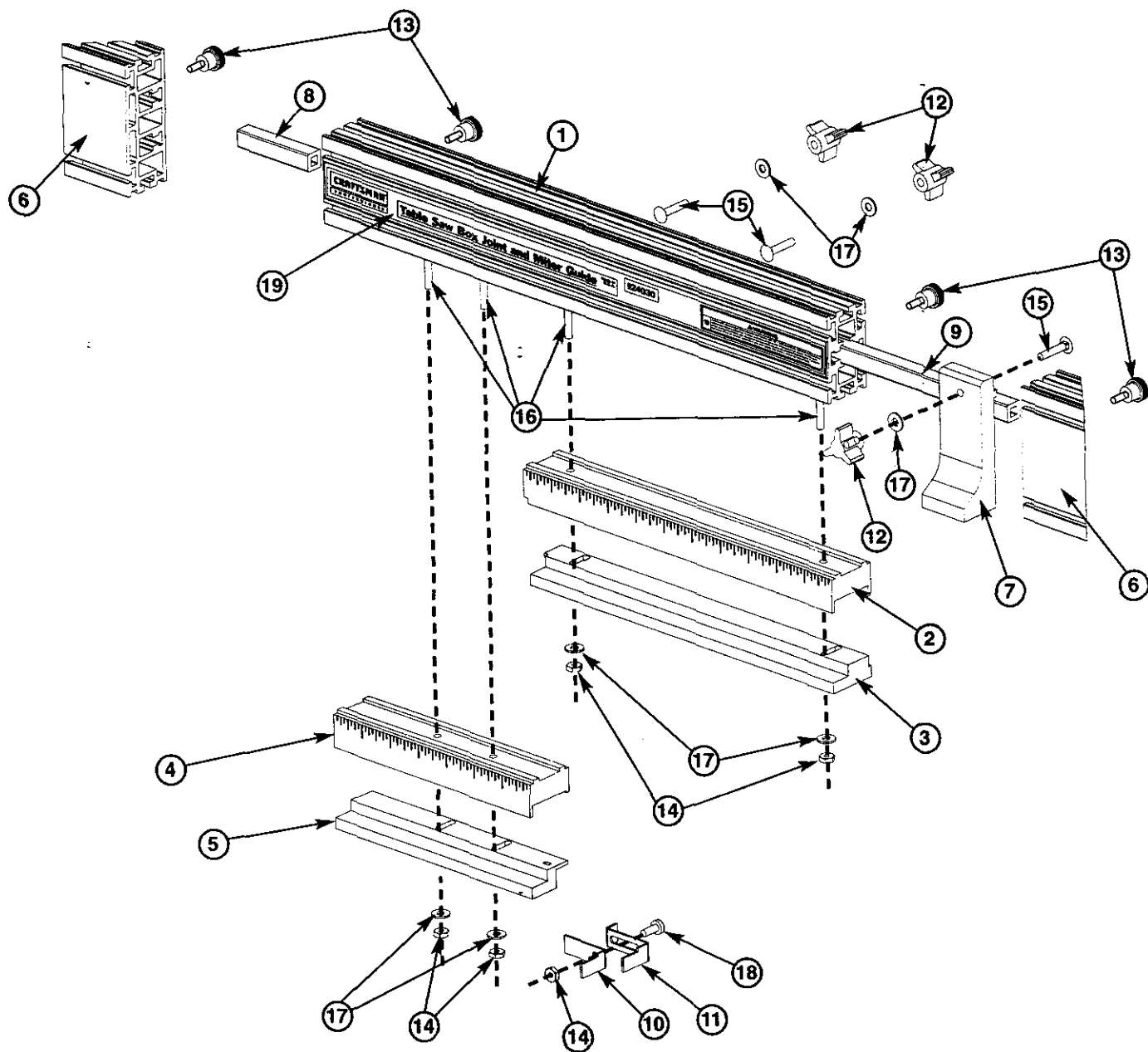
**FIGURE 30**



# PARTS LIST

PARTS LIST FOR CRAFTSMAN TABLE SAW BOX JOINT AND MITER GUIDE

MODEL NO. 171.240300



PARTS LIST

KEY NO.	QTY.	PART NO.	DESCRIPTION	KEY NO.	QTY.	PART NO.	DESCRIPTION
1	1	29LCN-1080	Guide - Aluminum Extrusion	12	3	31L-560-1	Three Wing Knob
2	1	29LCN-1081	Left Lower Guide	13	4	29LD-766-2	Round Knob
3	1	29LCN-1082	Left Slide	14	9	F29A-242-5	#10-24 Hex Nut
4	1	29LCN-1083	Right Lower Guide	15	3	F29A-310-10	#10-24 x 1 Carriage Bolt
5	1	29LCN-1084	Right Slide	16	4	F29A-310-26	#10-24 x 1-3/8 Carriage Bolt
6	2	29LCN-1085	End Cap	17	7	F29A-306-13	#10 Washer
7	1	29LCN-1086	Stop Piece	18	1	F29L-469-9	#10 x 3/8 Pan Head Machine Screw
8	1	29LCN-1087	Extension Tube - Short	19	1	45A-395	Product label/Warning Label
9	1	29LCN-1088	Extension Tube - Long		1	49DC-63	Instruction Manual (not illustrated)
10	1	29LCN-1089	Fixed Tab		1	60870	Tool Set (not illustrated)
11	1	29LCN-1090	Adjustable Tab				

# NOTES

# NOTES

Printed in U.S.A.  
05/98  
49DC-63

When corresponding, always give the following information as shown in the list.

1. The PART NUMBER
  2. The PART DESCRIPTION
  3. The MODEL NUMBER: 171.240300
  4. The ITEM NAME – TABLE SAW BOX JOINT  
AND MITER GUIDE
-