

Owner's Manual

CRAFTSMAN®

**19.5 HP
ELECTRIC START
42" MOWER
6 SPEED TRANSAXLE
LAWN TRACTOR**

Model No.
917.270811

- Safety
- Assembly
- Operation
- Maintenance
- Repair Parts

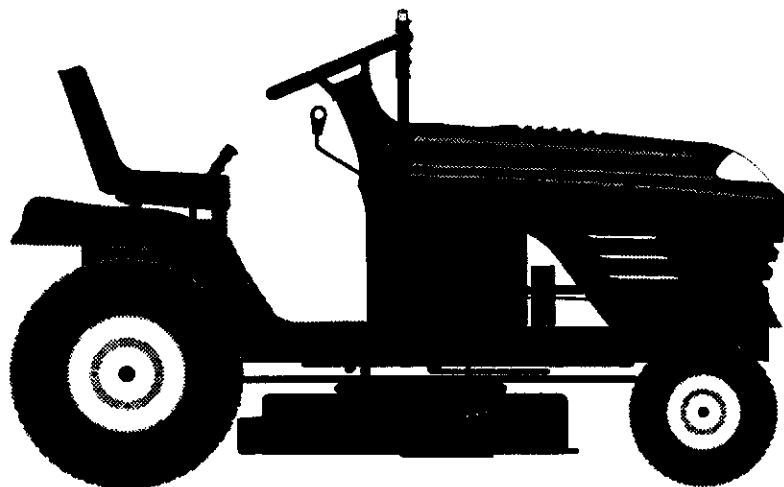

This product has a low emission engine which operates differently from previously built engines. Before you start the engine, read and understand this Owner's Manual.

CAUTION:

Read and follow all Safety Rules and Instructions before operating this equipment.

For answers to your questions about this product, Call:

1-800-659-5917
Sears Craftsman Help Line
5 am - 5 pm, Mon - Sat

TABLE OF CONTENTS

Warranty	2	Maintenance	18
Safety Rules	2	Service and Adjustments	22
Product Specifications	5	Storage	28
Assembly	8	Troubleshooting	29
Operation	12	Repair Parts	34
Maintenance Schedule	18	Parts Ordering	Back Cover

WARRANTY

LIMITED TWO YEAR WARRANTY ON CRAFTSMAN RIDING EQUIPMENT

For two (2) years from the date of purchase, if this Craftsman Riding Equipment is maintained, lubricated and tuned up according to the instructions in the owner's manual, Sears will repair or replace, free of charge, any parts found to be defective in material or workmanship.

This Warranty does not cover:

- Expendable items which become worn during normal use, such as blades, spark plugs, air cleaners, belts, etc.
- Tire replacement or repair caused by punctures from outside objects, such as nails, thorns, stumps, or glass.
- Repairs necessary because of operator abuse, negligence, improper storage or accident or the failure to maintain the equipment according to the instructions contained in the owner's manual.
- Riding equipment used for commercial or rental purposes.

LIMITED 90 DAY WARRANTY ON BATTERY

For ninety (90) days from date of purchase, if any battery included with this riding equipment proves defective in material or workmanship and our testing determines the battery will not hold a charge, Sears will replace the battery at no charge. In-home warranty service on your Craftsman riding equipment is available at no charge for 30 days from the date of purchase. Please contact your nearest service center. After 30 days from the date of purchase, warranty service is available by taking your Craftsman riding equipment to your nearest Sears Service Center. (In-home warranty service will still be available after 30 days from the date of purchase but a standard trip charge will apply). This warranty applies only while this product is in the United States. This Warranty gives you specific legal rights, and you may also have other rights which may vary from state to state.

Sears, Roebuck and Co., D/817 WA, Hoffman Estates, IL 60179

SAFETY RULES

GENERAL OPERATION

- Read, understand, and follow all instructions in the manual and on the machine before starting.
- Only allow responsible adults, who are familiar with the instructions, to operate the machine.
- Clear the area of objects such as rocks, toys, wire, etc., which could be picked up and thrown by the blade.
- Be sure the area is clear of other people before mowing. Stop machine if anyone enters the area.
- Never carry passengers.
- Do not mow in reverse unless absolutely necessary. Always look down and behind before and while backing.
- Be aware of the mower discharge direction and do not point it at anyone. Do not operate the mower without either the entire grass catcher or the guard in place.
- Slow down before turning.
- Never leave a running machine unattended. Always turn off blades, set parking brake, stop engine, and remove keys before dismounting.

SAFETY RULES

- Turn off blades when not mowing.
- Stop engine before removing grass catcher or unclogging chute.
- Mow only in daylight or good artificial light.
- Do not operate the machine while under the influence of alcohol or drugs.
- Watch for traffic when operating near or crossing roadways.
- Use extra care when loading or unloading the machine into a trailer or truck.

SLOPE OPERATION

Slopes are a major factor related to loss-of-control and tipover accidents, which can result in severe injury or death. All slopes require extra caution. If you cannot back up the slope or if you feel uneasy on it, do not mow it.

DO:

- Mow up and down slopes, not across.
- Remove obstacles such as rocks, tree limbs, etc.
- Watch for holes, ruts, or bumps. Uneven terrain could overturn the machine. Tall grass can hide obstacles.
- Use slow speed. Choose a low gear so that you will not have to stop or shift while on the slope.
- Follow the manufacturer's recommendations for wheel weights or counterweights to improve stability.
- Use extra care with grass catchers or other attachments. These can change the stability of the machine.
- Keep all movement on the slopes slow and gradual. Do not make sudden changes in speed or direction.
- Avoid starting or stopping on a slope. If tires lose traction, disengage the blades and proceed slowly straight down the slope.

DO NOT:

- Do not turn on slopes unless necessary, and then, turn slowly and gradually downhill, if possible.
- Do not mow near drop-offs, ditches, or embankments. The mower could suddenly turn over if a wheel is over the edge of a cliff or ditch, or if an edge caves in.
- Do not mow on wet grass. Reduced traction could cause sliding.

- Do not try to stabilize the machine by putting your foot on the ground.
- Do not use grass catcher on steep slopes.

CHILDREN

Tragic accidents can occur if the operator is not alert to the presence of children. Children are often attracted to the machine and the mowing activity. Never assume that children will remain where you last saw them.

- Keep children out of the mowing area and under the watchful care of another responsible adult.
- Be alert and turn machine off if children enter the area.
- Before and when backing, look behind and down for small children.
- Never carry children. They may fall off and be seriously injured or interfere with safe machine operation.
- Never allow children to operate the machine.
- Use extra care when approaching blind corners, shrubs, trees, or other objects that may obscure vision.

SERVICE

- Use extra care in handling gasoline and other fuels. They are flammable and vapors are explosive.
 - Use only an approved container.
 - Never remove gas cap or add fuel with the engine running. Allow engine to cool before refueling. Do not smoke.
 - Never refuel the machine indoors.
 - Never store the machine or fuel container inside where there is an open flame, such as a water heater.
- Never run a machine inside a closed area.
- Keep nuts and bolts, especially blade attachment bolts, tight and keep equipment in good condition.
- Never tamper with safety devices. Check their proper operation regularly.
- Keep machine free of grass, leaves, or other debris build-up. Clean oil or fuel spillage. Allow machine to cool before storing.
- Stop and inspect the equipment if you strike an object. Repair, if necessary, before restarting.

SAFETY RULES

- Never make adjustments or repairs with the engine running.
- Grass catcher components are subject to wear, damage, and deterioration, which could expose moving parts or allow objects to be thrown. Frequently check components and replace with manufacturer's recommended parts, when necessary.
- Mower blades are sharp and can cut. Wrap the blade(s) or wear gloves, and use extra caution when servicing them.
- Check brake operation frequently. Adjust and service as required.



- Be sure the area is clear of other people before mowing. Stop machine if anyone enters the area.
- Never carry passengers.
- Do not mow in reverse unless absolutely necessary. Always look down and behind before and while backing.
- Never carry children. They may fall off and be seriously injured or interfere with safe machine operation.
- Keep children out of the mowing area and under the watchful care of another responsible adult.
- Be alert and turn machine off if children enter the area.
- Before and when backing, look behind and *down* for small children.
- Mow up and down slopes (15° Max), not across.
- Remove obstacles such as rocks, tree limbs, etc.
- Watch for holes, ruts, or bumps. Uneven terrain could overturn the machine. *Tall grass can hide obstacles.*
- Use slow speed. Choose a low gear so that you will not have to stop or shift while on the slope.
- Avoid starting or stopping on a slope. If tires lose traction, disengage the blades and proceed slowly *straight* down the slope.
- *Do not* turn on slopes unless necessary, and then, turn slowly and gradually downhill, if possible.

▲ Look for this symbol to point out important safety precautions. It means **CAUTION!!! BECOME AWARE!!! YOUR SAFETY IS INVOLVED.**

▲ CAUTION: In order to prevent accidental starting when setting up, transporting, adjusting or making repairs always disconnect spark plug wire and place wire where it cannot contact spark plug.

▲ WARNING: The engine exhaust from this product contains chemicals known to the State of California to cause cancer, birth defects, or other reproductive harm.

PRODUCT SPECIFICATIONS

GASOLINE CAPACITY AND TYPE:	3.5 GALLONS UNLEADED REGULAR
OIL TYPE (API-SF/SG/SH):	SAE 30 (above 32°F) SAE 5W-30 (below 32°F)
OIL CAPACITY:	3.0 PINTS
SPARK PLUG: (GAP: .030")	Champion RJ19LM OR J19LM
VALVE CLEARANCE:	INTAKE: .004"-.006" EXHAUST: .007"-.009"
GROUND SPEED (MPH):	FORWARD: 1ST 1.1 2ND 1.5 3RD 2.3 4TH 3.5 5TH 4.7 6TH 5.4 REVERSE: 1.5
TIRE PRESSURE:	FRONT: 14 PSI REAR: 10 PSI
CHARGING SYSTEM:	3 AMPS BATTERY 5 AMPS HEADLIGHTS
BATTERY:	AMP/HR: 30 MIN. CCA: 240 CASE SIZE: U1R
BLADE BOLT TORQUE:	27-35 FT. LBS.

CONGRATULATIONS on your purchase of a Craftsman Tractor. It has been designed, engineered and manufactured to give you the best possible dependability and performance.

Should you experience any problem you cannot easily remedy, please contact your nearest Sears Authorized Service Center. We have competent, well-trained technicians and the proper tools to service or repair this tractor.

Please read and retain this manual. The instructions will enable you to assemble and maintain your tractor properly. Always observe the "SAFETY RULES".

MAINTENANCE AGREEMENT

A Sears Maintenance Agreement is available on this product. Contact your nearest Sears store for details.

CUSTOMER RESPONSIBILITIES

- Read and observe the safety rules.
- Follow a regular schedule in maintaining, caring for and using your tractor.
- Follow the instructions under "Maintenance" and "Storage" sections of this owner's manual.

▲WARNING: This tractor is equipped with an internal combustion engine and should not be used on or near any unimproved forest-covered, brush-covered or grass-covered land unless the engine's exhaust system is equipped with a spark arrester meeting applicable local or state laws (if any). If a spark arrester is used, it should be maintained in effective working order by the operator.

In the state of California the above is required by law (Section 4442 of the California Public Resources Code). Other states may have similar laws. Federal laws apply on federal lands. A spark arrester for the muffler is available through your nearest Sears Authorized Service Center (See REPAIR PARTS section of this manual).

CONTENTS OF HARDWARE PACK

PARTS BAG CONTENTS SHOWN FULL SIZE

(1) Large Flat Washer

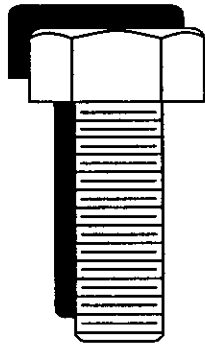
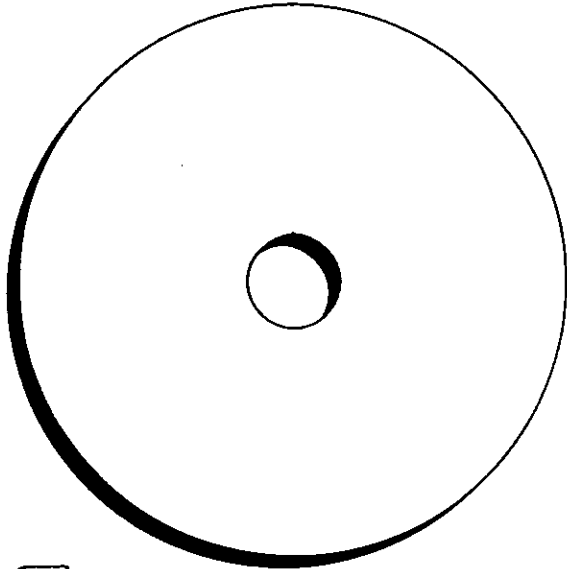

(1) Hex Bolt
3/8-16 x 1



(1) Lockwasher
3/8



(1) Hex Bolt
5/16-18 x 1-1/4



(1) Locknut
5/16-18

(1) Shoulder Bolt
5/16-18

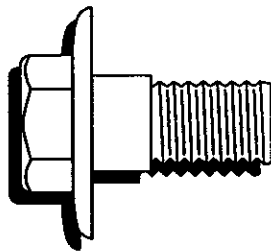

(1) Washer
17/32 x 1-3/16 x 12 Gauge

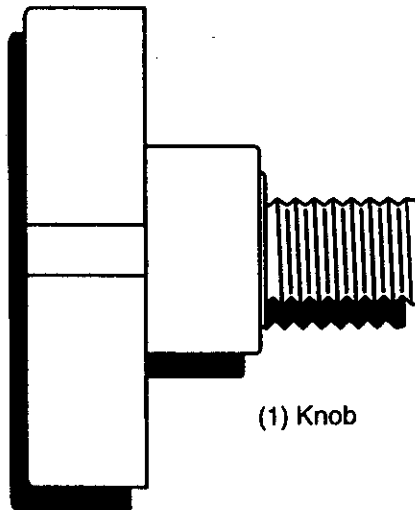
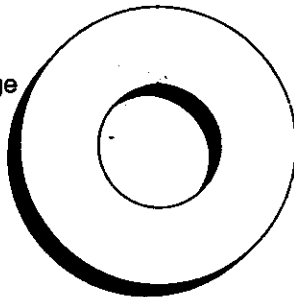

(1) Knob

CONTENTS OF HARDWARE PACK

PARTS BAG CONTENTS SHOWN FULL SIZE

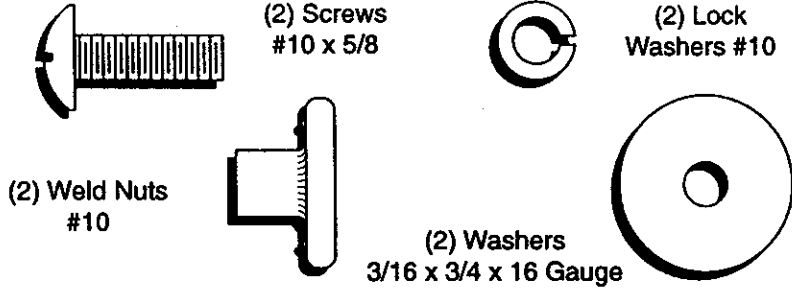

Parts packet separately in carton

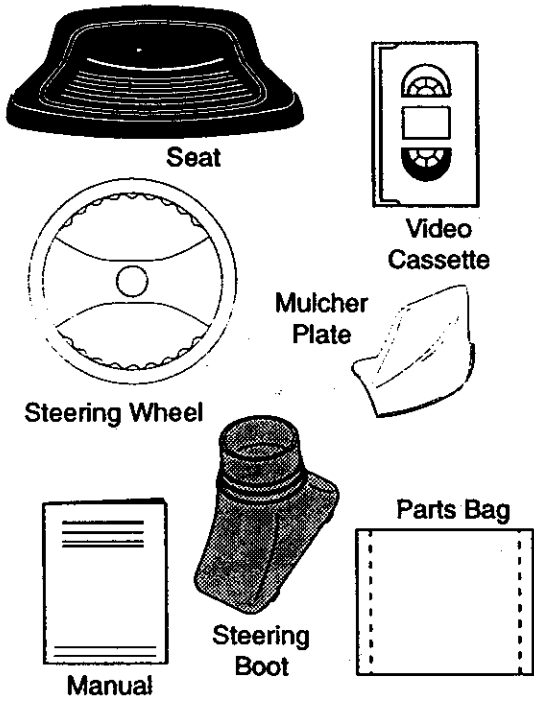

Parts Bag contents not shown full size

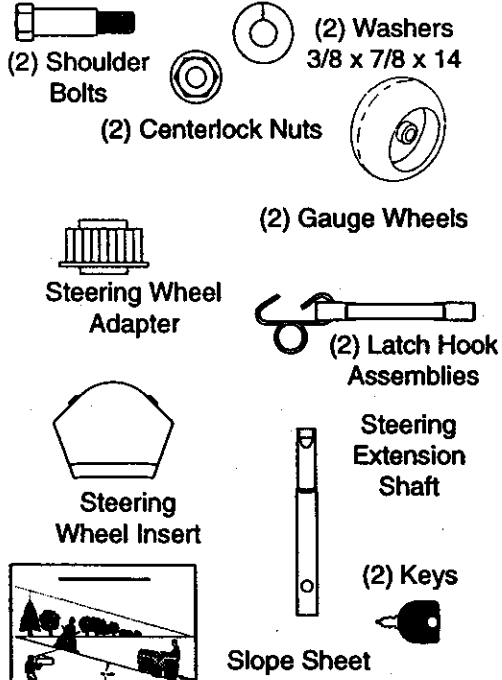

ASSEMBLY

Your new tractor has been assembled at the factory with exception of those parts left unassembled for shipping purposes. To ensure safe and proper operation of your tractor all parts and hardware you assemble must be tightened securely. Use the correct tools as necessary to insure proper tightness. Review the video cassette before you begin.

TOOLS REQUIRED FOR ASSEMBLY

A socket wrench set will make assembly easier. Standard wrench sizes you need are listed below.

- | | |
|------------------------------------|-------------------------|
| (1) 9/16" wrench | (2) 1/2" wrench |
| (1) Phillips Screw-driver | (1) Pliers |
| (1) Utility knife | (1) Tire pressure gauge |
| (1) 3/4" socket with drive ratchet | |

When right or left hand is mentioned in this manual, it means, from your point of view, when you are in the operating position (seated behind the steering wheel).

TO REMOVE TRACTOR FROM CARTON

UNPACK CARTON

- Remove all accessible loose parts and parts boxes from shipping carton (See page 6).
- Cut, from top to bottom, along lines on all four corners of shipping carton, and lay panels flat.
- Check for any additional loose parts or boxes and remove.

BEFORE ROLLING TRACTOR OFF SKID

ATTACH STEERING WHEEL

ASSEMBLE EXTENSION SHAFT AND BOOT

- Slide extension shaft onto lower steering shaft. Align mounting holes in extension and lower shafts and install 5/16 hex bolt and locknut. Tighten securely.

IMPORTANT: Tighten bolt and nut securely to 18-22 ft. lbs. torque.

- Place tabs of steering boot over tab slots in dash and push down to secure.

INSTALL STEERING WHEEL

- Position front wheels of the tractor so they are pointing straight forward.
- Slide steering wheel adapter onto steering shaft extension.

- Position steering wheel so cross bars are horizontal (left to right) and slide inside boot and onto adapter.
- Assemble large flat washer, 3/8 lock washer, 3/8 hex bolt and tighten securely.
- Snap steering wheel insert into center of steering wheel.
- Remove protective materials from tractor hood and grill.

IMPORTANT: Check for and remove any staples in skid that may puncture tires where tractor is to roll off skid.

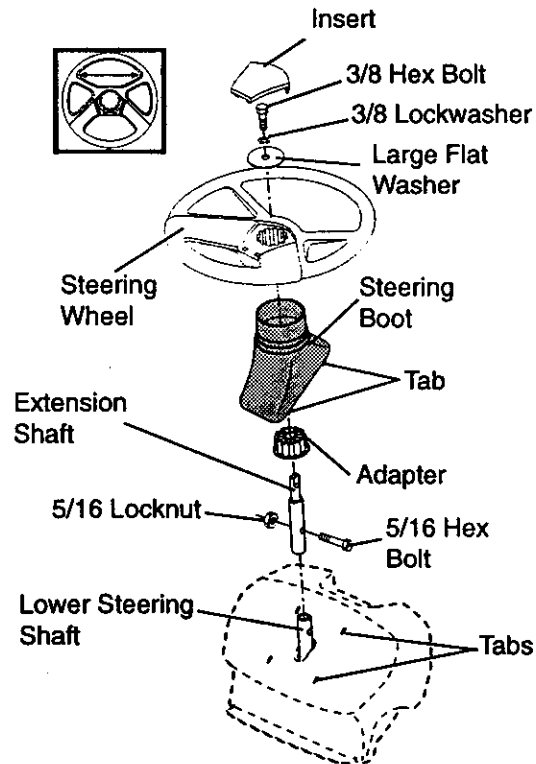

TO ROLL TRACTOR OFF SKID (See Operation section for location and function of controls)

- Press lift lever plunger and raise attachment lift lever to its highest position.
- Release parking brake by depressing clutch/brake pedal.
- Place gearshift lever in neutral (N) position.
- Roll tractor forward off skid.
- Remove banding holding discharge guard up against tractor.

HOW TO SET UP YOUR TRACTOR CONNECT BATTERY

- Lift hood to raised position.
- If this battery is put into service after month and year indicated on label (label located between terminals) charge battery for minimum of one hour at 6-10 amps. (See "BATTERY" in MAINTENANCE section of this manual for charging instructions).

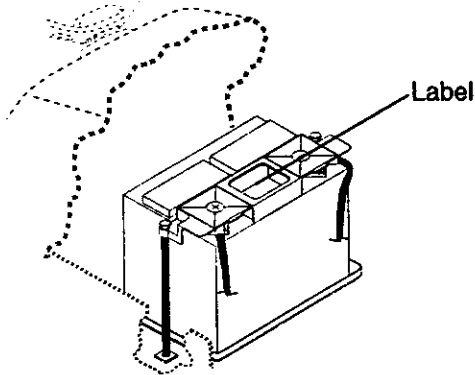

INSTALL SEAT

Adjust seat before tightening adjustment knob.

- Remove cardboard packing on seat pan.
- Place seat on seat pan and assemble shoulder bolt. Tighten shoulder bolt securely.
- Assemble adjustment knob and flat washer loosely. Do not tighten.
- Lower seat into operating position and sit on seat.
- Slide seat until a comfortable position is reached which allows you to press clutch/brake pedal all the way down.
- Get off seat without moving its adjusted position.
- Raise seat and tighten adjustment knob securely.

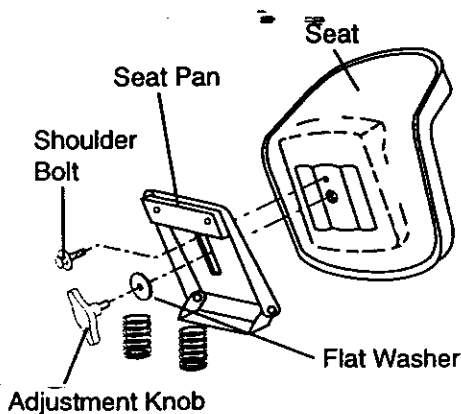

INSTALL MULCHER PLATE

- Install two latch hooks to mulcher plate using screw, washer, lock washer, and weld nut as shown.

NOTE: Pre-assemble weld nut to latch hook by inserting weld nut from the top with hook pointing down.

- Tighten hardware securely.
- Raise and hold deflector shield in upright position.
- Place front of mulcher plate over front of mower deck opening and slide into place, as shown.
- Hook front latch into hole on front of mower deck.
- Hook rear latch into hole on back of mower deck.

CAUTION: Do not remove discharge guard from mower. Raise and hold guard when attaching mulcher plate and allow it to rest on plate while in operation.

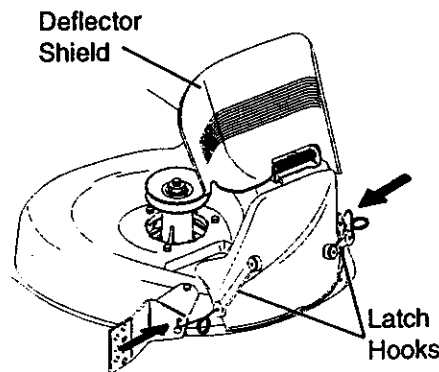
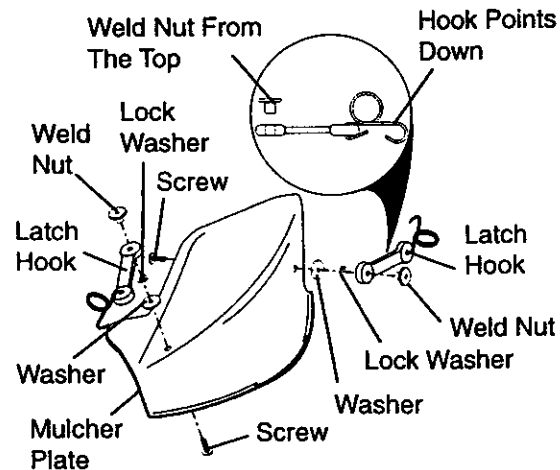

TO CONVERT TO BAGGING OR DISCHARGING

Simply remove mulcher plate and store in a safe place. Your mower is now ready for discharging or installation of optional grass catcher accessory.

NOTE: It is not necessary to change blades. The mulcher blades are designed for discharging and bagging also.

ASSEMBLE GAUGE WHEELS TO MOWER DECK

The gauge wheels are designed to keep the mower deck in proper position when operating mower. Be sure they are properly adjusted to ensure optimum mower performance.

- Assemble gauge wheels with tractor on a flat level surface.
- Adjust mower to desired cutting height (See "TO ADJUST MOWER CUTTING HEIGHT" in the Operation section of this manual).
- With mower in desired height of cut position, gauge wheels should be assembled so they are slightly off the ground. Install gauge wheel in appropriate hole with shoulder bolt, 3/8 washer, and 3/8-16 locknut and tighten securely.
- Repeat for opposite side installing gauge wheel in same adjustment hole.

Gauge Wheel Mounting Bracket

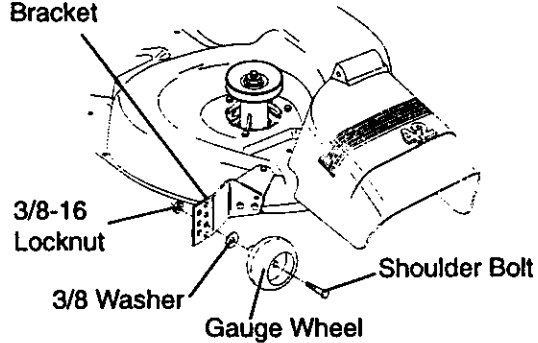

CHECK TIRE PRESSURE

The tires on your tractor were overinflated at the factory for shipping purposes.

Correct tire pressure is important for best cutting performance.

- Reduce tire pressure to PSI shown in "PRODUCT SPECIFICATIONS" section of this manual.

CHECK DECK LEVELNESS

For best cutting results, mower housing should be properly leveled. See "TO LEVEL MOWER HOUSING" in the Service and Adjustments section of this manual.

CHECK FOR PROPER POSITION OF ALL BELTS

See the figures that are shown for replacing motion and mower blade drive belts in the Service and Adjustments section of this manual. Verify that the belts are routed correctly.

CHECK BRAKE SYSTEM

After you learn how to operate your tractor, check to see that the brake is properly adjusted. See "TO ADJUST BRAKE" in the Service and Adjustments section of this manual.

✓ CHECKLIST

PLEASE REVIEW THE FOLLOWING CHECKLIST:

- ✓ All assembly instructions have been completed.
- ✓ No remaining loose parts in carton.
- ✓ Battery is properly prepared and charged. (Minimum 1 hour at 6 amps).
- ✓ Seat is adjusted comfortably and tightened securely.
- ✓ All tires are properly inflated. (For shipping purposes, the tires were overinflated at the factory).
- ✓ Be sure mower deck is properly leveled side-to-side/front-to-rear for best cutting results. (Tires must be properly inflated for leveling).
- ✓ Check mower and drive belts. Be sure they are routed properly around pulleys and inside all belt keepers.
- ✓ Check wiring. See that all connections are still secure and wires are properly clamped.

WHILE LEARNING HOW TO USE YOUR TRACTOR, PAY EXTRA ATTENTION TO THE FOLLOWING IMPORTANT ITEMS:

- ✓ Engine oil is at proper level.
- ✓ Fuel tank is filled with fresh, clean, regular unleaded gasoline.
- ✓ Become familiar with all controls - their location and function. Operate them before you start the engine.
- ✓ Be sure brake system is in safe operating condition.

OPERATION

These symbols may appear on your tractor or in literature supplied with the product. Learn and understand their meaning.

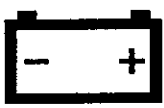

BATTERY



CAUTION OR WARNING



REVERSE



FORWARD



FAST



SLOW



ENGINE ON



ENGINE OFF



OIL PRESSURE



LIGHTS ON



OVER TEMP LIGHT



MOWER LIFT



FUEL



CHOKE



MOWER HEIGHT



PARKING BRAKE LOCKED



UNLOCKED



MOWER LIFT



ATTACHMENT CLUTCH ENGAGED



REVERSE



NEUTRAL



HIGH



LOW



PARKING BRAKE



IGNITION



ATTACHMENT CLUTCH DISENGAGED



KEEP AREA CLEAR



SLOPE HAZARDS

(SEE SAFETY RULES SECTION)



DANGER, KEEP HANDS AND FEET AWAY

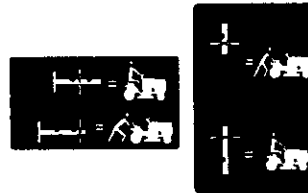

FREE WHEEL
(Automatic Models only)

KNOW YOUR TRACTOR

READ THIS OWNER'S MANUAL AND SAFETY RULES BEFORE OPERATING YOUR TRACTOR

Compare the illustrations with your tractor to familiarize yourself with the locations of various controls and adjustments. Save this manual for future reference.

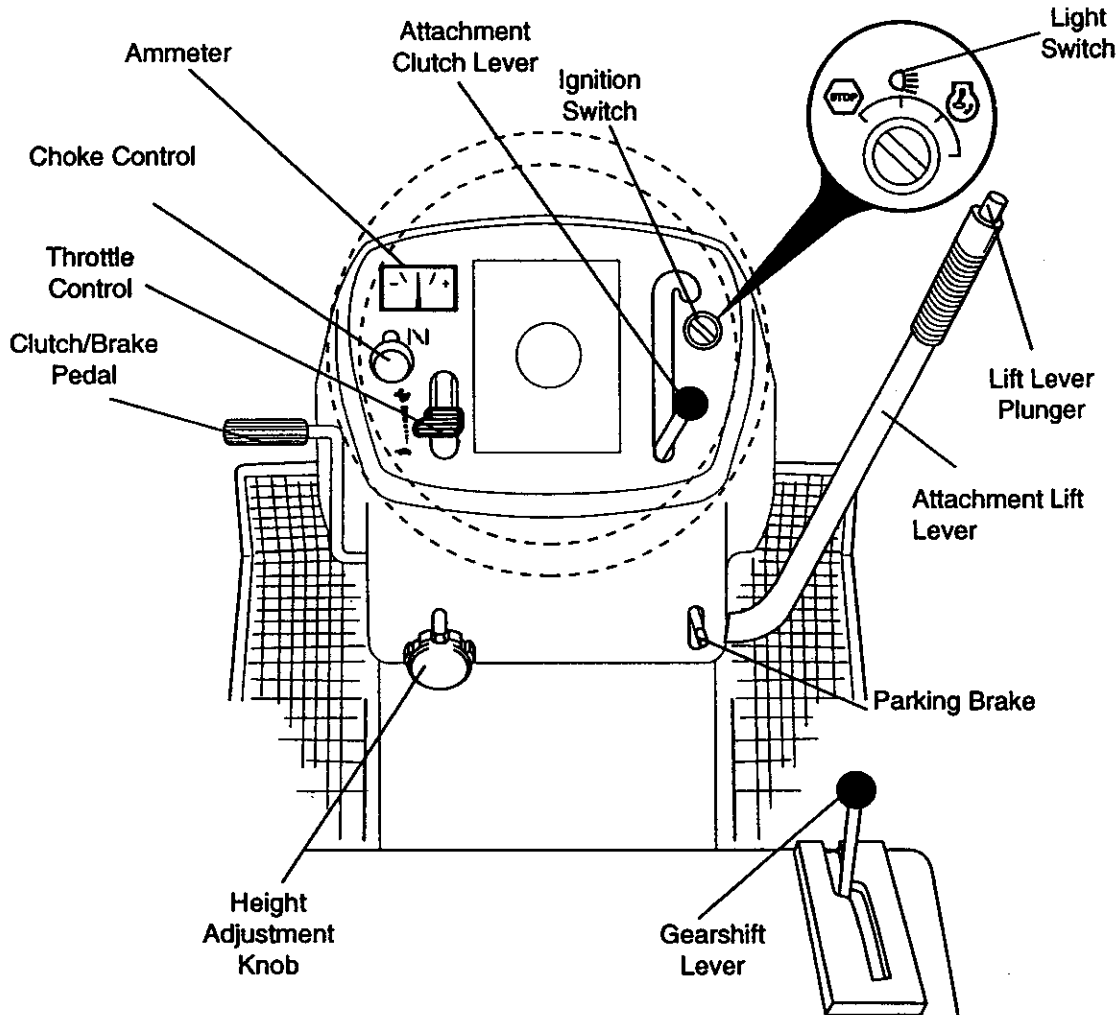

Our tractors conform to the safety standards of the American National Standards Institute.

ATTACHMENT CLUTCH LEVER: Used to engage the mower blades, or other attachments mounted to your tractor.

LIGHT SWITCH: Turns the headlights on and off.

THROTTLE CONTROL: Used for starting and controlling engine speed.

CHOKE CONTROL: Used when starting a cold engine.

CLUTCH/BRAKE PEDAL: Used for declutching and braking the tractor and starting the engine.

PARKING BRAKE: Locks clutch/brake pedal into the brake position.

HEIGHT ADJUSTMENT KNOB: Used to adjust the mower cutting height.

GEARSHIFT LEVER: Selects the speed and direction of tractor.

ATTACHMENT LIFT LEVER: Used to raise, lower, and adjust the mower deck or other attachments mounted to your tractor.

LIFT LEVER PLUNGER: Used to release attachment lift lever when changing its position.

IGNITION SWITCH: Used for starting and stopping the engine.

AMMETER: Indicates battery charging (+) or discharging (-).



The operation of any tractor can result in foreign objects thrown into the eyes, which can result in severe eye damage. Always wear safety glasses or eye shields while operating your tractor or performing any adjustments or repairs. We recommend a wide vision safety mask over spectacles, or standard safety glasses.

HOW TO USE YOUR TRACTOR

Your tractor is equipped with an operator presence sensing switch. When engine is running, any attempt by the operator to leave the seat without first setting the parking brake will shut off the engine.

TO SET PARKING BRAKE

- Depress clutch/brake pedal into full "BRAKE" position and hold.
- Place parking brake lever in "ENGAGED" position and release pressure from clutch/brake pedal. Pedal should remain in "BRAKE" position. Make sure parking brake will hold tractor secure.

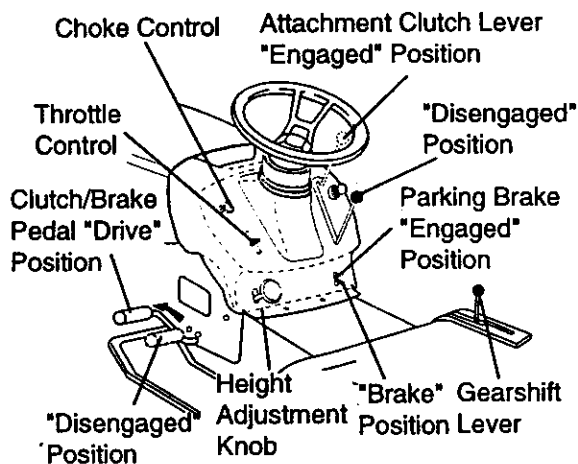

before stopping may cause engine to "backfire".

- Turn ignition key to "OFF" position and remove key. Always remove key when leaving tractor to prevent unauthorized use.
- Never use choke to stop engine.

IMPORTANT: Leaving the ignition switch in any position other than "OFF" will cause the battery to be discharged, (dead).

NOTE: Under certain conditions when tractor is standing idle with the engine running, hot engine exhaust gases may cause "browning" of grass. To eliminate this possibility, always stop engine when stopping tractor on grass areas.

▲ CAUTION: Always stop tractor completely, as described above, before leaving the operator's position; to empty grass catcher, etc.

THROTTLE CONTROL

Always operate engine at full throttle.

- Operating engine at less than full throttle reduces the battery charging rate.
- Full throttle offers the best bagging and mower performance.

CHOKE CONTROL

Use choke control whenever you are starting a cold engine. Do not use to start a warm engine.

- To engage choke control, pull knob out. Slowly push knob in to disengage.

TO MOVE FORWARD AND BACKWARD

The direction and speed of movement is controlled by the gearshift lever.

- Start tractor with clutch/brake pedal depressed and gearshift lever in neutral (N) position.
- Move gearshift lever to desired position.
- Slowly release clutch/brake pedal to start movement.

IMPORTANT: Bring tractor to a complete stop before shifting or changing gears. Failure to do so will shorten the useful life of your transaxle.

STOPPING

MOWER BLADES -

- To stop mower blades, move attachment clutch lever to "DISENGAGED" position.

GROUND DRIVE -

- To stop ground drive, depress clutch/brake pedal into full "BRAKE" position.
- Move gearshift lever to neutral (N) position.

ENGINE -

- Move throttle control to slow position.

NOTE: Failure to move throttle control to slow position and allowing engine to idle

TO ADJUST MOWER CUTTING HEIGHT

The cutting height is controlled by turning the height adjustment knob in desired direction.

- Turn knob clockwise (C) to raise cutting height.
- Turn knob counterclockwise (O) to lower cutting height.

The cutting height range is approximately 1-1/2" to 4". The heights are measured from the ground to the blade tip with the engine not running. These heights are approximate and may vary depending upon soil conditions, height of grass and types of grass being mowed.

- The average lawn should be cut to approximately 2-1/2 inches during the cool season and to over 3 inches during hot months. For healthier and better looking lawns, mow often and after moderate growth.
- For best cutting performance, grass over 6 inches in height should be mowed twice. Make the first cut relatively high; the second to desired height.

TO OPERATE MOWER

Your tractor is equipped with an operator presence sensing switch. Any attempt by the operator to leave the seat with the engine running and the attachment clutch engaged will shut off the engine.

- Select desired height of cut.
- Lower mower with attachment lift control.
- Start mower blades by engaging attachment clutch control.
- TO STOP MOWER BLADES - disengage attachment clutch control.

▲CAUTION: Do not operate the mower without either the entire grass catcher, on mowers so equipped, or the discharge guard in place.

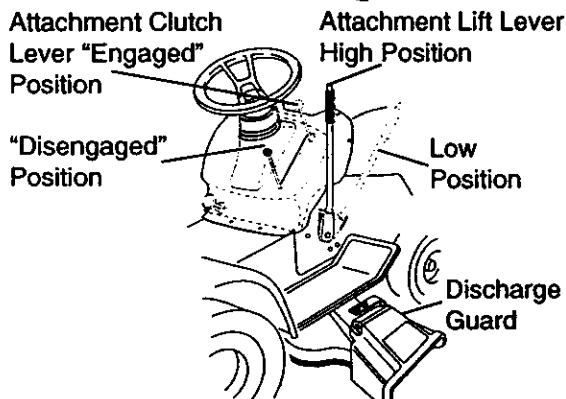

TO OPERATE ON HILLS

▲CAUTION: Do not drive up or down hills with slopes greater than 15° and do not drive across any slope. A slope guide at the back of your manual is provided for your use.

- Choose the slowest speed before starting up or down hills.
- Avoid stopping or changing speed on hills.
- If slowing is necessary, move throttle control lever to slower position.
- If stopping is absolutely necessary, push clutch/brake pedal quickly to brake position and engage parking brake.
- Move gearshift lever to 1st gear. Be sure you have allowed room for tractor to roll slightly as you restart movement.
- To restart movement, slowly release parking brake and clutch/brake pedal.
- Make all turns slowly.

TO TRANSPORT

- Raise attachment lift to highest position with attachment lift control.
- When pushing or towing your tractor, be sure gearshift lever is in neutral (N) position.
- Do not push or tow tractor at more than five (5) MPH.

NOTE: To protect hood from damage when transporting your tractor on a truck or a trailer, be sure hood is closed and secured to tractor. Use an appropriate means of tying hood to tractor (rope, cord, etc.).

TOWING CARTS AND OTHER ATTACHMENTS

Tow only the attachments that are recommended by and comply with specifications of the manufacturer of your tractor. Use common sense when towing. Too heavy of a load, while on a slope, is dangerous. Tires can lose traction with the ground and cause you to lose control of your tractor.

BEFORE STARTING THE ENGINE

CHECK ENGINE OIL LEVEL

- The engine in your tractor has been shipped, from the factory, already filled with summer weight oil.
- Check engine oil with tractor on level ground.
- Remove oil fill cap/dipstick and wipe clean, reinsert the dipstick and screw

cap tight, wait for a few seconds, remove and read oil level. If necessary, add oil until "FULL" mark on dipstick is reached. Do not overfill.

- For cold weather operation you should change oil for easier starting (See "OIL VISCOSITY CHART" in the Maintenance section of this manual).
- To change engine oil, see the Maintenance section in this manual.

ADD GASOLINE

- Fill fuel tank. Use fresh, clean, regular unleaded gasoline with a minimum of 87 octane. (Use of leaded gasoline will increase carbon and lead oxide deposits and reduce valve life). Do not mix oil with gasoline. Purchase fuel in quantities that can be used within 30 days to assure fuel freshness.

IMPORTANT: When operating in temperatures below 32°F(0°C), use fresh, clean winter grade gasoline to help insure good cold weather starting.

▲WARNING: Experience indicates that alcohol blended fuels (called gasohol or using ethanol or methanol) can attract moisture which leads to separation and formation of acids during storage. Acidic gas can damage the fuel system of an engine while in storage. To avoid engine problems, the fuel system should be emptied before storage of 30 days or longer. Drain the gas tank, start the engine and let it run until the fuel lines and carburetor are empty. Use fresh fuel next season. See Storage Instructions for additional information. Never use engine or carburetor cleaner products in the fuel tank or permanent damage may occur.

▲CAUTION: Fill to bottom of gas tank filler neck. Do not overfill. Wipe off any spilled oil or fuel. Do not store, spill or use gasoline near an open flame.

TO START ENGINE

When starting the engine for the first time or if the engine has run out of fuel, it will take extra cranking time to move fuel from the tank to the engine.

- Sit on seat in operating position, depress clutch/brake pedal and set parking brake.
- Place gear shift lever in neutral (N) position.
- Move attachment clutch to "DISENGAGED" position.
- Move throttle control to fast position

- Pull choke control out for a cold engine start attempt. For a warm engine start attempt the choke control may not be needed.

NOTE: Before starting, read the warm and cold starting procedures below.

- Insert key into ignition and turn key clockwise to "START" position and release key as soon as engine starts. Do not run starter continuously for more than fifteen seconds per minute. If the engine does not start after several attempts, push choke control in, wait a few minutes and try again. If engine still does not start, pull the choke control out and retry.

WARM WEATHER STARTING (50° F AND ABOVE)

- When engine starts, slowly push choke control in until the engine begins to run smoothly. If the engine starts to run roughly, pull the choke control out slightly for a few seconds and then continue to push the control in slowly.
- The attachments and ground drive can now be used. If the engine does not accept the load, restart the engine and allow it to warm up for one minute using the choke as described above.

COLD WEATHER STARTING (50° F AND BELOW)

- When engine starts, slowly push choke control in until the engine begins to run smoothly. Continue to push the choke control in small steps allowing the engine to accept small changes in speed and load, until the choke control is fully in. If the engine starts to run roughly, pull the choke control out slightly for a few seconds and then continue to push the control in slowly. This may require an engine warm-up period from several seconds to several minutes, depending on the temperature.
- The attachments can be used during the engine warm-up period and may require the choke control be pulled out slightly.

NOTE: A high altitude (above 3000 feet) or in cold temperatures (below 32 F) the carburetor fuel mixture may need to be adjusted for best engine performance. See "TO ADJUST CARBURETOR" in the Service and Adjustments section of this manual.

MAINTENANCE

CUSTOMER RESPONSIBILITIES

MAINTENANCE SCHEDULE		SERVICE INTERVALS							SERVICE DATES				
		BEFORE EACH USE	EVERY 8 HOURS	EVERY 25 HOURS	EVERY 50 HOURS	EVERY 100 HOURS	EVERY SEASON	BEFORE STORAGE					
TRACTOR	Check Brake Operation	✓	✓										
	Check Tire Pressure	✓	✓										
	Check Operator Presence and Interlock Systems	✓											
	Check for Loose Fasteners	✓				✓ ₇		✓					
	Sharpen/Replace Mower Blades			✓ ₄									
	Lubrication Chart			✓				✓					
	Check Battery Level			✓ ₆									
	Clean Battery and Terminals			✓				✓					
	Check Transaxle Cooling			✓									
	Adjust Blade Belt(s) Tension					✓ ₅							
	Adjust Motion Drive Belt(s) Tension					✓ ₅							
ENGINE	Check Engine Oil Level	✓	✓					✓					
	Change Engine Oil			✓ _{1,2,3}				✓					
	Clean Air Filter			✓ ₂									
	Clean Air Screen			✓ ₂									
	Inspect Muffler/Spark Arrester				✓								
	Replace Oil Filter (If equipped)					✓ _{1,2}							
	Clean Engine Cooling Fins					✓ ₂							
	Replace Spark Plug					✓ _{1,2}	✓						
	Replace Air Filter Paper Cartridge					✓ ₂							
Replace Fuel Filter						✓							

- 1 - Change more often when operating under a heavy load or in high ambient temperatures. 5 - If equipped with adjustable system.
 2 - Service more often when operating in dirty or dusty conditions. 6 - Not required if equipped with maintenance-free battery.
 3 - If equipped with oil filter, change oil every 50 hours. 7 - Tighten front axle pivot bolt to 35 ft.-lbs. maximum.

GENERAL RECOMMENDATIONS

The warranty on this tractor does not cover items that have been subjected to operator abuse or negligence. To receive full value from the warranty, operator must maintain tractor as instructed in this manual. Some adjustments will need to be made periodically to properly maintain your tractor.

All adjustments in the Service and Adjustments section of this manual should be checked at least once each season.

- Once a year you should replace the spark plug, clean or replace air filter, and check blades and belts for wear. A new spark plug and clean air filter assure proper air-fuel mixture and help your engine run better and last longer.

BEFORE EACH USE

- Check engine oil level.
- Check brake operation.
- Check tire pressure.
- Check operator presence and interlock systems for proper operation.
- Check for loose fasteners.

LUBRICATION CHART

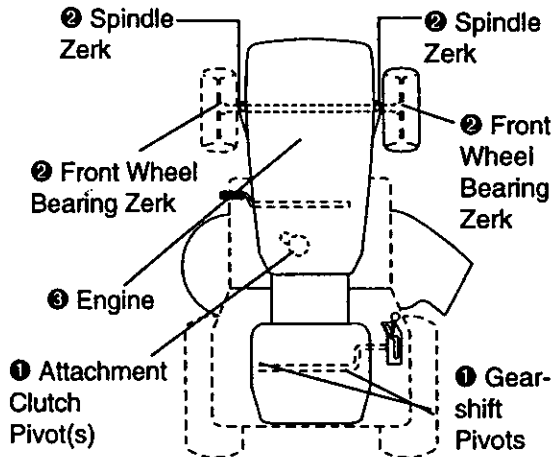

- ① SAE 30 or 10w30 Motor OIL
- ② General Purpose Grease
- ③ Refer to Maintenance "Engine" Section

IMPORTANT: Do not oil or grease the pivot points which have special nylon bearings. Viscous lubricants will attract dust and dirt that will shorten the life of the self-lubricating bearings. If you feel they must be lubricated, use only a dry, powdered graphite type lubricant sparingly.

TRACTOR

Always observe safety rules when performing any maintenance.

BRAKE OPERATION

If tractor requires more than six (6) feet stopping distance at high speed in highest gear, then brake must be adjusted. (See "TO ADJUST BRAKE" in the Service and Adjustments section of this manual).

TIRES

- Maintain proper air pressure in all tires (See "PRODUCT SPECIFICATIONS" section of this manual).
- Keep tires free of gasoline, oil, or insect control chemicals which can harm rubber.
- Avoid stumps, stones, deep ruts, sharp objects and other hazards that may cause tire damage.

NOTE: To seal tire punctures and prevent flat tires due to slow leaks, tire sealant may be purchased from your local parts dealer. Tire sealant also prevents tire dry rot and corrosion.

OPERATOR PRESENCE SYSTEM

Be sure that operator presence and interlock systems are working properly. If your tractor does not function as described below, repair the problem immediately.

- The engine should not start unless the clutch/brake pedal is fully depressed and attachment clutch control is in the disengaged position.
- When the engine is running, any attempt by the operator to leave the seat without first setting the parking brake should shut off the engine.
- When the engine is running and the attachment clutch is engaged, any attempt by the operator to leave the seat should shut off the engine.
- The attachment clutch should never operate unless the operator is in the seat.

BLADE CARE

For best results mower blades must be kept sharp. Replace bent or damaged blades.

BLADE REMOVAL

- Raise mower to highest position to allow access to blades.
- Remove hex bolt, lock washer and flat washer securing blade.
- Install new or resharpened blade with trailing edge up towards deck as shown.

IMPORTANT: To ensure proper assembly, center hole in blade must align with star on mandrel assembly.

- Reassemble hex bolt, lock washer and flat washer in exact order as shown.
- Tighten bolt securely (27-35 Ft. Lbs. torque).

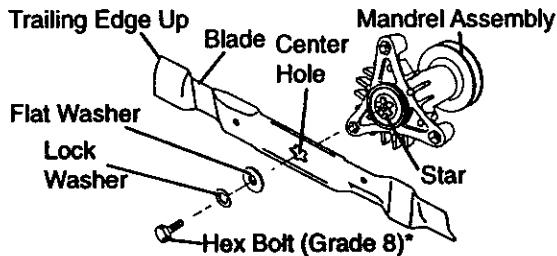

*A Grade 8 heat treated bolt can be identified by six lines on the bolt head.

IMPORTANT: Blade bolt is Grade 8 heat treated.

TO SHARPEN BLADE

NOTE: We do not recommend sharpening blade, but if you do, be sure the blade is balanced.

Care should be taken to keep the blade balanced. An unbalanced blade will cause excessive vibration and eventual damage to mower and engine.

- The blade can be sharpened with a file or on a grinding wheel. Do not attempt to sharpen while it is on the mower.
- To check blade balance, you will need a 5/8" diameter steel bolt, pin, or a cone balancer. (When using a cone balancer, follow the instructions supplied with balancer).

NOTE: Do not use a nail for balancing blade. The lobes of the center hole may appear to be centered, but are not.

- Slide blade onto an unthreaded portion of the steel bolt or pin and hold the bolt or pin parallel with the ground. If blade is balanced, it should remain in a horizontal position. If either end of the blade moves downward, sharpen the heavy end until the blade is balanced.

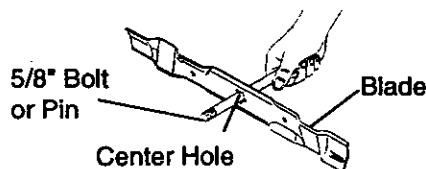

BATTERY

Your tractor has a battery charging system which is sufficient for normal use.

However, periodic charging of the battery with an automotive charger will extend its life.

- Keep battery and terminals clean.
 - Keep battery bolts tight.
 - Keep small vent holes open.
 - Recharge at 6-10 amperes for 1 hour.
- NOTE:** The original equipment battery on your tractor is maintenance free. Do not attempt to open or remove caps or covers. Adding or checking level of electrolyte is not necessary.

TO CLEAN BATTERY AND TERMINALS
Corrosion and dirt on the battery and terminals can cause the battery to "leak" power.

- Remove terminal guard.
- Disconnect **BLACK** battery cable first then **RED** battery cable and remove battery from tractor.
- Rinse the battery with plain water and dry.
- Clean terminals and battery cable ends with wire brush until bright.
- Coat terminals with grease or petroleum jelly.
- Reinstall battery (See "REPLACING BATTERY" in the SERVICE AND ADJUSTMENTS section of this manual).

V-BELTS

Check V-belts for deterioration and wear after 100 hours of operation and replace if necessary. The belts are not adjustable. Replace belts if they begin to slip from wear.

TRANSAXLE COOLING

Keep transaxle free from build-up of dirt and chaff which can restrict cooling.

ENGINE

LUBRICATION

Only use high quality detergent oil rated with API service classification SF, SG or SH. Select the oil's SAE viscosity grade according to your expected operating temperature.

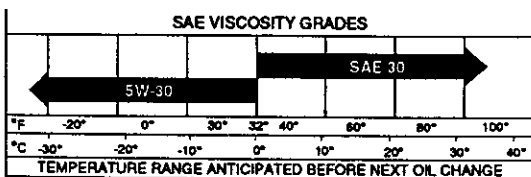

NOTE: Although multi-viscosity oils (5W30, 10W30 etc.) improve starting in cold weather, these multi-viscosity oils will result in increased oil consumption when used above 32°F. Check your engine oil

level more frequently to avoid possible engine damage from running low on oil. Change the oil after every 25 hours of operation or at least once a year if the tractor is not used for 25 hours in one year.

Check the crankcase oil level before starting the engine and after each eight (8) hours of operation. Tighten oil fill cap/dipstick securely each time you check the oil level.

TO CHANGE ENGINE OIL

Determine temperature range expected before oil change. All oil must meet API service classification SF, SG or SH.

- Be sure tractor is on level surface.
- Oil will drain more freely when warm.
- Catch oil in a suitable container.
- Remove oil fill cap/dipstick. Be careful not to allow dirt to enter the engine when changing oil.
- Remove drain plug.
- After oil has drained completely, replace oil drain plug and tighten securely.
- Refill engine with oil through oil fill dipstick tube. Pour slowly. Do not overfill. For approximate capacity see "PRODUCT SPECIFICATIONS" section of this manual.
- Use gauge on oil fill cap/dipstick for checking level. Be sure dipstick cap is tightened securely for accurate reading. Keep oil at "FULL" line on dipstick.

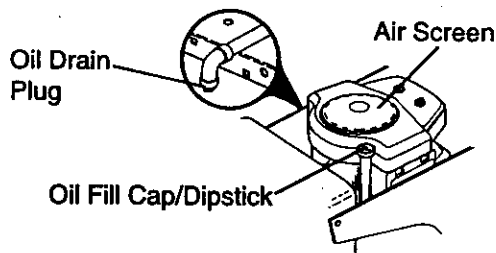

AIR FILTER

Your engine will not run properly using a dirty air filter. Clean the foam pre-cleaner after every 25 hours of operation or every season. Service paper cartridge every 100 hours of operation or every season, whichever occurs first.

Service air cleaner more often under dusty conditions.

- Remove knob(s) and cover.
- TO SERVICE PRE-CLEANER**

- Slide foam pre-cleaner off cartridge.
- Wash it in liquid detergent and water.
- Squeeze it dry in a clean cloth.

- Saturate it in engine oil. Wrap it in clean, absorbent cloth and squeeze to remove excess oil.
- If very dirty or damaged, replace pre-cleaner.
- Reinstall pre-cleaner over cartridge.
- Reinstall cover and secure with knob(s).

TO SERVICE CARTRIDGE

- Remove wing nuts and cartridge plate.
- Carefully remove cartridge to prevent debris from entering carburetor.
- Clean cartridge by tapping gently on flat surface. If very dirty or damaged, replace cartridge.
- Reinstall cartridge plate, wing nuts, pre-cleaner, cover and secure with knob(s).

IMPORTANT: Petroleum solvents, such as kerosene, are not to be used to clean the cartridge. They may cause deterioration of the cartridge. Do not oil cartridge. Do not use pressurized air to clean or dry cartridge.

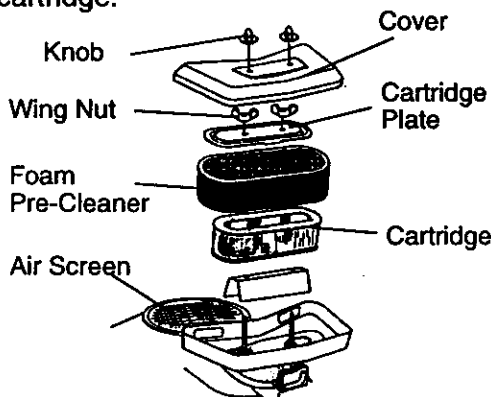

CLEAN AIR SCREEN

Air screen must be kept free of dirt and chaff to prevent engine damage from overheating. Clean with a wire brush or compressed air to remove dirt and stubborn dried gum fibers.

ENGINE COOLING FINS

Remove any dust, dirt or oil from engine cooling fins to prevent engine damage from overheating. Air guide covers must be removed. Remove side panels and hood (See "TO REMOVE HOOD AND GRILL ASSEMBLY" in the Service and Adjustments section of this manual).

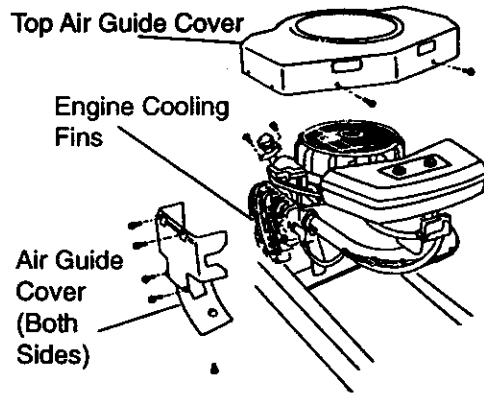

MUFFLER

Inspect and replace corroded muffler and spark arrester (if equipped) as it could create a fire hazard and/or damage.

SPARK PLUGS

Replace spark plugs at the beginning of each mowing season or after every 100 hours of operation, whichever occurs first. Spark plug type and gap setting are shown in "PRODUCT SPECIFICATIONS" section of this manual.

IN-LINE FUEL FILTER

The fuel filter should be replaced once each season. If fuel filter becomes clogged, obstructing fuel flow to carburetor, replacement is required.

- With engine cool, remove filter and plug fuel line sections.
- Place new fuel filter in position in fuel line with arrow pointing towards carburetor.
- Be sure there are no fuel line leaks and clamps are properly positioned.
- Immediately wipe up any spilled gasoline.

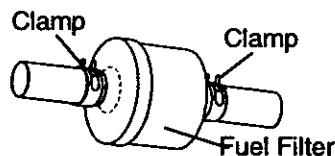

CLEANING

- Clean engine, battery, seat, finish, etc. of all foreign matter.
- Keep finished surfaces and wheels free of all gasoline, oil, etc.
- Protect painted surfaces with automotive type wax.

We do not recommend using a garden hose to clean your tractor unless the electrical system, muffler, air filter and carburetor are covered to keep water out. Water in engine can result in a shortened engine life.

SERVICE AND ADJUSTMENTS

▲ CAUTION: Before performing any service or adjustments:

- Depress clutch/brake pedal fully and set parking brake.
- Place gearshift lever in neutral (N) position.
- Place attachment clutch in "DISENGAGED" position.
- Turn ignition key "OFF" and remove key.
- Make sure the blades and all moving parts have completely stopped.
- Disconnect spark plug wire from spark plug and place wire where it cannot come in contact with plug.

TRACTOR

TO REMOVE MOWER

Mower will be easier to remove from the right side of tractor.

- Place attachment clutch in "DISENGAGED" position.
- Move attachment lift lever forward to lower mower to its lowest position.
- Roll belt off engine pulley.
- Disconnect clutch rod from clutch lever by removing retainer spring.
- Disconnect anti-swaybar from chassis bracket by removing retainer spring.
- Disconnect suspension arms from rear deck brackets by removing retainer springs.

- Disconnect front links from deck by removing retainer springs.
- Raise lift lever to raise suspension arms. Slide mower out from under tractor.

IMPORTANT: If an attachment other than the mower deck is to be mounted on the tractor, remove the front links.

TO INSTALL MOWER

- Raise attachment lift lever to its highest position.
- Slide mower under tractor with discharge guard to right side of tractor.
- Lower lift lever to its lowest position.
- Install mower in reverse order of removal instructions.

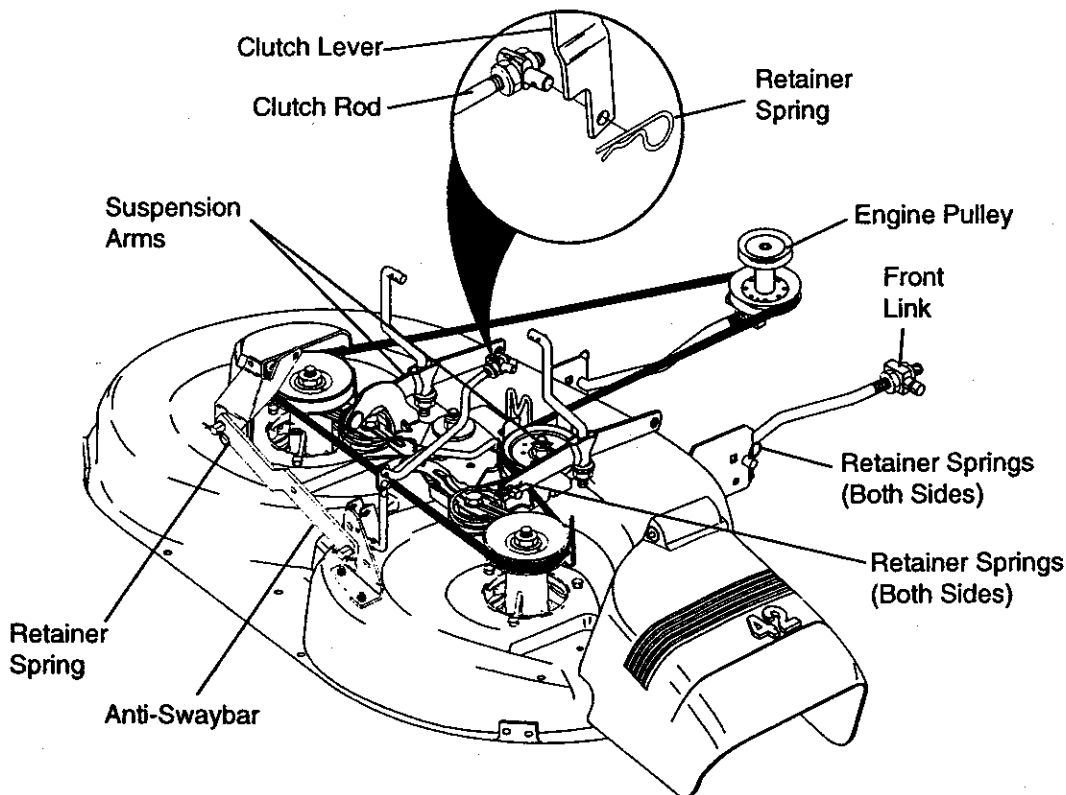

TO LEVEL MOWER HOUSING

Adjust the mower while tractor is parked on level ground or driveway. Make sure tires are properly inflated (See "PRODUCT SPECIFICATIONS" section of this manual). If tires are over or underinflated, you will not properly adjust your mower.

SIDE-TO-SIDE ADJUSTMENT

- Raise mower to its highest position.
- At the midpoint of both sides of mower, measure height from bottom edge of mower to ground. Distance "A" on both sides of mower should be the same or within 1/4" of each other.
- If adjustment is necessary, make adjustment on one side of mower only.
- To raise one side of mower, tighten lift link adjustment nut on that side.
- To lower one side of mower, loosen lift link adjustment nut on that side.

NOTE: Each full turn of adjustment nut will change mower height about 1/8".

- Recheck measurements after adjusting.

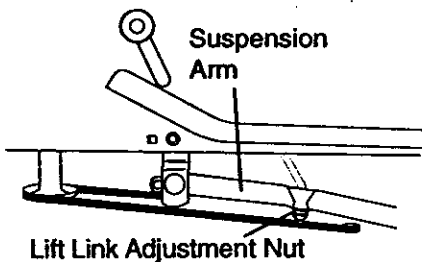
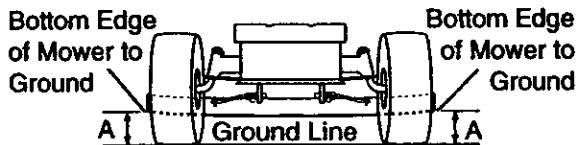

FRONT-TO-BACK ADJUSTMENT

IMPORTANT: Deck must be level side-to-side. If the following front-to-back adjustment is necessary, be sure to adjust both front links equally so mower will stay level side-to-side.

To obtain the best cutting results, the mower housing should be adjusted so that the front is approximately 1/8" to 1/2" lower than the rear when the mower is in its highest position.

Check adjustment on right side of tractor. Measure distance "D" directly in front and behind the mandrel at bottom edge of mower housing as shown.

- Before making any necessary adjustments, check that both front links are

equal in length. Both links should be approximately 10-3/8".

- If links are not equal in length, adjust one link to same length as other link.
- To lower front of mower loosen nut "E" on both front links an equal number of turns.
- When distance "D" is 1/8" to 1/2" lower at front than rear, tighten nuts "F" against trunnion on both front links.
- To raise front of mower, loosen nut "F" from trunnion on both front links. Tighten nut "E" on both front links an equal number of turns.
- When distance "D" is 1/8" to 1/2" lower at front than rear, tighten nut "F" against trunnion on both front links.
- Recheck side-to-side adjustment.

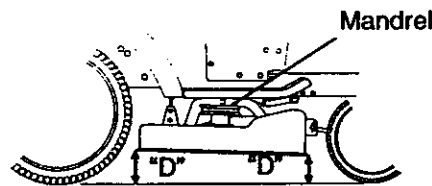

Both Front Links Should be Equal in Length

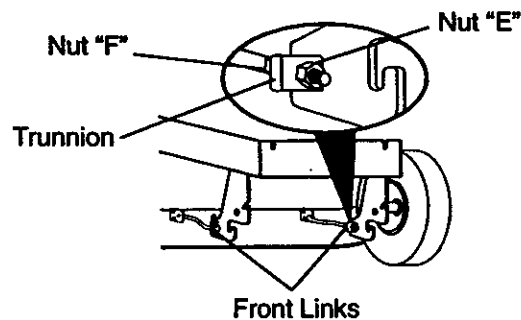
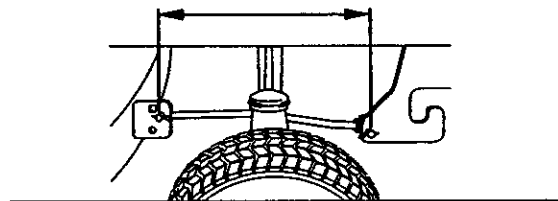

TO REPLACE MOWER BLADE DRIVE BELT (See Illustration Next Page)

The mower blade drive belt may be replaced without tools. Park the tractor on level surface. Engage parking brake.

BELT REMOVAL -

- Remove mower from tractor (See "TO REMOVE MOWER" in this section of this manual).
- Work belt off both mandrel pulleys and idler pulleys.
- Pull belt away from mower.

BELT INSTALLATION -

- Install new belt in reverse order of removal.

- Make sure belt is in all pulley grooves and inside all belt guides.
- Install mower in reverse order of removal instructions.

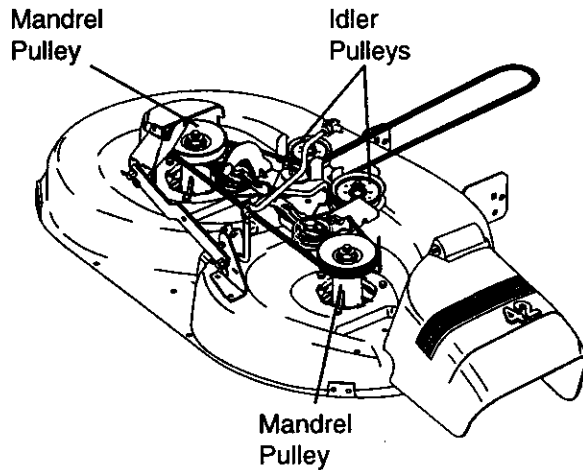

TO ADJUST BRAKE

Your tractor is equipped with an adjustable brake system which is mounted on the right side of the transaxle.

If tractor requires more than six (6) feet stopping distance at high speed in highest gear, then brake must be adjusted.

- Depress clutch/brake pedal and engage parking brake.
- Measure distance between brake operating arm and nut "A" on brake rod.
- If distance is other than 1-1/2", loosen jam nut and turn nut "A" until distance becomes 1-1/2". Retighten jam nut against nut "A".
- Road test tractor for proper stopping distance as stated above. Readjust if necessary. If stopping distance is still greater than six (6) feet in highest gear, further maintenance is necessary. Contact your nearest authorized service center/department.

With Parking Brake Engaged*

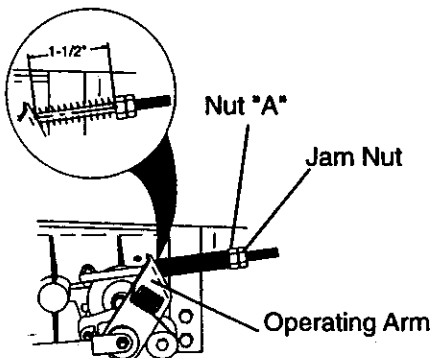

TO REPLACE MOTION DRIVE BELT

Park the tractor on level surface. Engage parking brake. For assistance, there is a belt installation guide decal on bottom side of left footrest.

- Remove mower (See "TO REMOVE MOWER" in this section of this manual.)
- Remove belt from stationary idler and clutching idler.
- Pull belt slack toward rear of tractor. Remove belt upwards from transaxle pulley by deflecting belt keepers.
- Pull belt toward front of tractor and remove downwards from around engine pulley.
- Install new belt by reversing above procedure.

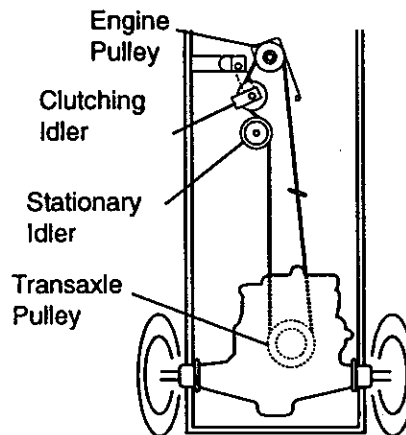

TRANSAXLE SHIFTER LINKAGE AND ADJUSTMENT

The transaxle should be in neutral when the gear shift lever is in the neutral (N) (lock gate) position. The adjustment is preset at the factory; however, if adjustment is needed, proceed as follows:

- Make sure transaxle is in neutral (N).
- Loosen two locknuts on tie rod.
- Turn center rod until gearshift lever falls into neutral lock gate on fender console.
- Tighten locknuts securely.

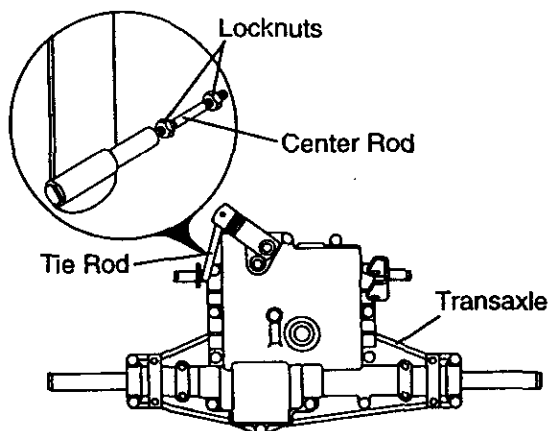
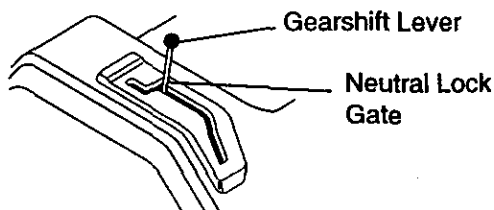

- Replace washers and snap retaining ring securely in axle groove.
- Replace axle cover.

NOTE: To seal tire punctures and prevent flat tires due to slow leaks, tire sealant may be purchased from your local parts dealer. Tire sealant also prevents tire dry rot and corrosion.

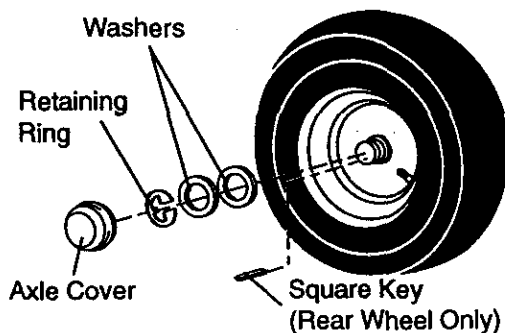

TO START ENGINE WITH A WEAK BATTERY

CAUTION: Lead-acid batteries generate explosive gases. Keep sparks, flame and smoking materials away from batteries. Always wear eye protection when around batteries.

If your battery is too weak to start the engine, it should be recharged. (See "BATTERY" in the MAINTANCE section of this manual).

If "jumper cables" are used for emergency starting, follow this procedure:

IMPORTANT: Your tractor is equipped with a 12 volt negative grounded system. The other vehicle must also be a 12 volt negative grounded system. Do not use your tractor battery to start other vehicles.

TO ATTACH JUMPER CABLES -

- Connect each end of the RED cable to the POSITIVE (+) terminal of each battery, taking care not to short against chassis.
- Connect one end of the BLACK cable to the NEGATIVE (-) terminal of fully charged battery.
- Connect the other end of the BLACK cable to good CHASSIS GROUND, away from fuel tank and battery.

TO REMOVE CABLES, REVERSE ORDER -

- BLACK cable first from chassis and then from the fully charged battery.
- RED cable last from both batteries.

TO ADJUST STEERING WHEEL ALIGNMENT

If steering wheel crossbars are not horizontal (left to right) when wheels are positioned straight forward, remove steering wheel and reassemble per instructions in the Assembly section of this manual.

FRONT WHEEL TOE-IN/CAMBER

The front wheel toe-in and camber are not adjustable on your tractor. If damage has occurred to affect the front wheel toe-in or camber, contact your nearest authorized service center/department.

TO REMOVE WHEEL FOR REPAIRS

- Block up axle securely.
- Remove axle cover, retaining ring and washers to allow wheel removal (rear wheel contains a square key - Do not lose).
- Repair tire and reassemble.
- On rear wheels only: align grooves in rear wheel hub and axle. Insert square key.

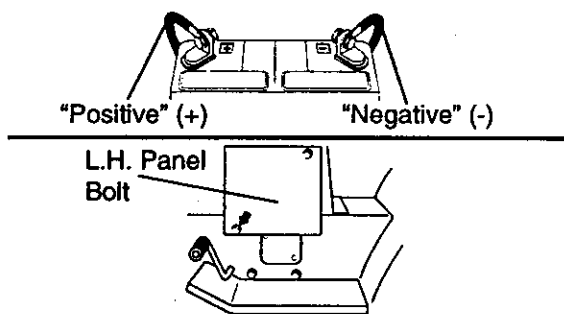

REPLACING BATTERY

▲CAUTION: Do not short battery terminals by allowing a wrench or any other object to contact both terminals at the same time. Before connecting battery, remove metal bracelets, wristwatch bands, rings, etc.

Positive terminal must be connected first to prevent sparking from accidental grounding.

- Lift hood to raised position.
- Remove terminal guard.
- Disconnect BLACK battery cable then RED battery cable and carefully remove battery from tractor.
- Install new battery with terminals in same position as old battery.
- Reinstall terminal guard.
- First connect RED battery cable to positive (+) battery terminal with hex bolt and keps nut as shown. Tighten securely.
- Connect BLACK grounding cable to negative (-) battery terminal with remaining hex bolt and keps nut. Tighten securely.
- Close terminal access doors.
- Close hood.

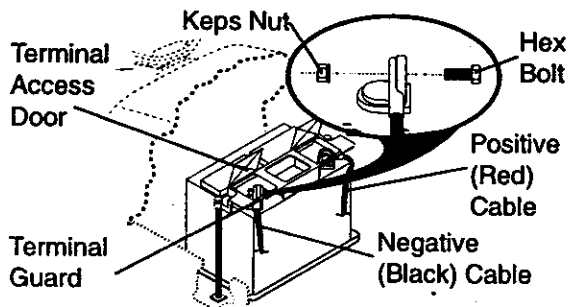

TO REPLACE HEADLIGHT BULB

- Raise hood.
- Pull bulb holder out of the hole in the backside of the grill.
- Replace bulb in holder and push bulb holder securely back into the hole in the backside of the grill.
- Close hood.

INTERLOCKS AND RELAYS

Loose or damaged wiring may cause your tractor to run poorly, stop running, or prevent it from starting.

- Check wiring. See electrical wiring diagram in the Repair Parts section.

TO REPLACE FUSE

Replace with 30 amp automotive-type plug-in fuse. The fuse holder is located behind the dash.

TO REMOVE HOOD AND GRILL ASSEMBLY

- Raise hood.
- Unsnap headlight wire connector.
- Stand in front of tractor. Grasp hood at sides, tilt toward engine and lift off of tractor.
- To replace, reverse above procedures.

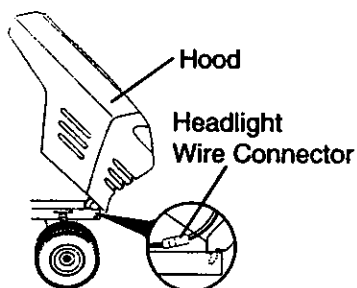

ENGINE

Maintenance, repair, or replacement of the emission control devices and systems, which are being done at the customer's expense, may be performed by any non-road engine repair establishment or individual. Warranty repairs must be performed by an authorized engine manufacturer's service outlet.

TO ADJUST THROTTLE CONTROL CABLE

The throttle control has been preset at the factory and adjustment should not be necessary. Check adjustment as described below before loosening cable. If adjustment is necessary, proceed as follows:

- With engine not running, move throttle control lever to fast position.
- Check that swivel is against side of quarter circle. If it is not, loosen cable clamp screw and pull cable back until swivel is against quarter circle. Tighten cable clamp screw securely.

TO ADJUST CHOKE CONTROL

The choke control has been preset at the factory and adjustment should not be necessary. Check adjustment as described

below before loosening cable. If adjustment is necessary, proceed as follows:

- With engine not running, move choke control (located on dash panel) to full choke position.
- Remove air cleaner cover, filter and cartridge plate to expose carburetor choke (see "AIR FILTER" in the Maintenance section of this manual).
- Choke should be closed. If it is not, loosen casing clamp screw and move choke cable until choke is completely closed. Tighten casing clamp screw securely.
- Reassemble air cleaner.

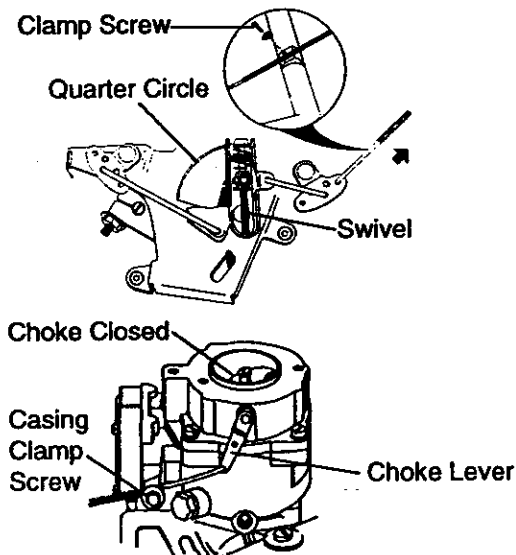

TO ADJUST CARBURETOR

The carburetor has been preset at the factory and adjustment should not be necessary. However, minor adjustment may be required to compensate for differences in fuel, temperature, altitude or load. If the carburetor does need adjustment, proceed as follows:

In general, turning the mixture screw in (clockwise) decreases the supply of fuel to the engine giving a leaner fuel/air mixture. Turning the mixture screw out (counterclockwise) increases the supply of fuel to the engine giving a richer fuel/air mixture. **IMPORTANT:** Damage to the needles and the seats in carburetor may result if screw is turned in too tight.

PRELIMINARY SETTING -

- Be sure you have a clean air filter, and the throttle control cable and choke are adjusted properly (see above).
- With engine off turn idle mixture screw in (clockwise) closing it finger tight and

then turn out (counterclockwise) 1-1/4 to 1-1/2 turns.

FINAL SETTING -

- Start engine and allow to warm for five minutes. Make final adjustments with engine running and shift/ motion control lever in neutral (N) position.
- With throttle control lever in slow position, hold throttle lever against idle speed screw and adjust idle speed screw to obtain 1200 to 1400 RPM.
- While still holding throttle lever against idle speed screw, turn idle mixture screw in (clockwise) until engine begins to die and then turn out (counterclockwise) until engine runs rough. Turn screw to a point midway between those two positions.
- Continue to hold throttle lever against idle speed screw and adjust idle speed screw to obtain 900 to 1200 RPM. Release throttle lever.

ACCELERATION TEST -

- Move throttle control lever from slow to fast position. If engine hesitates or dies, turn idle mixture screw out (counterclockwise) 1/8 turn. Repeat test and continue to adjust, if necessary, until engine accelerates smoothly.

High speed stop is factory adjusted. Do not adjust - damage may result.

IMPORTANT: Never tamper with the engine governor, which is factory set for proper engine speed. Overspeeding the engine above the factory high speed setting can be dangerous. If you think the engine-governed high speed needs adjusting, contact your nearest authorized service center/department, which has proper equipment and experience to make any necessary adjustments.

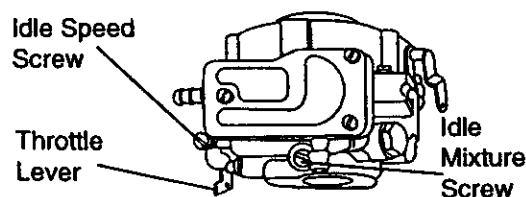
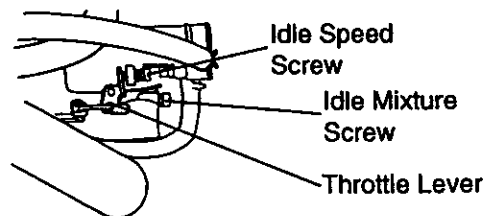

STORAGE

Immediately prepare your tractor for storage at the end of the season or if the tractor will not be used for 30 days or more.

▲ CAUTION: Never store the tractor with gasoline in the tank inside a building where fumes may reach an open flame or spark. Allow the engine to cool before storing in any enclosure.

TRACTOR

Remove mower from tractor for winter storage. This will allow you to clean it thoroughly. Remove all dirt, grease, leaves, etc. Store in a clean, dry area.

- Clean entire tractor (See "CLEANING" in the Maintenance section of this manual).
- Inspect and replace belts, if necessary (See belt replacement instructions in the Service and Adjustments section of this manual).
- Lubricate as shown in the Maintenance section of this manual.
- Be sure that all nuts, bolts and screws are securely fastened. Inspect moving parts for damage, breakage and wear. Replace if necessary.
- Touch up all rusted or chipped paint surfaces; sand lightly before painting.

BATTERY

- Fully charge the battery for storage.
- After a period of time in storage, battery may require recharging.
- To help prevent corrosion and power leakage during long periods of storage, battery cables should be disconnected and battery cleaned thoroughly (see "TO CLEAN BATTERY AND TERMINALS" in the Maintenance section of this manual).
- After cleaning, leave cables disconnected and place cables where they cannot come in contact with battery terminals.
- If battery is removed from tractor for storage, do not store battery directly on concrete or damp surfaces.

ENGINE

FUEL SYSTEM

IMPORTANT: It is important to prevent gum deposits from forming in essential fuel system parts such as carburetor, fuel filter, fuel hose, or tank during storage. Also, experience indicates that alcohol blended

fuels (called gasohol or using ethanol or methanol) can attract moisture which leads to separation and formation of acids during storage. Acidic gas can damage the fuel system of an engine while in storage.

- Drain the fuel tank.
- Start the engine and let it run until the fuel lines and carburetor are empty.
- Never use engine or carburetor cleaner products in the fuel tank or permanent damage may occur.
- Use fresh fuel next season.

NOTE: Fuel stabilizer is an acceptable alternative in minimizing the formation of fuel gum deposits during storage. Add stabilizer to gasoline in fuel tank or storage container. Always follow the mix ratio found on stabilizer container. Run engine at least 10 minutes after adding stabilizer to allow the stabilizer to reach the carburetor. Do not drain the gas tank and carburetor if using fuel stabilizer.

ENGINE OIL

Drain oil (with engine warm) and replace with clean engine oil. (See "ENGINE" in the Maintenance section of this manual).

CYLINDER(S)

- Remove spark plug(s).
- Pour one ounce of oil through spark plug hole(s) into cylinder(s).
- Turn ignition key to "START" position for a few seconds to distribute oil.
- Replace with new spark plug(s).

OTHER

- Do not store gasoline from one season to another.
- Replace your gasoline can if it starts to rust. Rust and/or dirt in your gasoline will cause problems.
- If possible, store your tractor indoors and cover it to give protection from dust and dirt.
- Cover your tractor with a suitable protective cover that does not retain moisture. Do not use plastic. Plastic cannot breathe, which allows condensation to form and cause your tractor to rust.

IMPORTANT: Never cover tractor while engine and exhaust areas are still warm.

TROUBLESHOOTING CHART

PROBLEM	CAUSE	CORRECTION
Will not start	<ul style="list-style-type: none"> • Out of fuel. • Engine not "CHOKED" properly. • Engine flooded. • Bad spark plug. • Dirty air filter. • Dirty fuel filter. • Water in fuel. • Loose or damaged wiring. • Carburetor out of adjustment. • Engine valves out of adjustment. 	<ul style="list-style-type: none"> • Fill fuel tank. • See "TO START ENGINE" in Operation section. • Wait several minutes before attempting to start. • Replace spark plug. • Clean/replace air filter. • Replace fuel filter. • Drain fuel tank and carburetor, refill tank with fresh gasoline and replace fuel filter. • Check all wiring. • See "To Adjust Carburetor" in Service and Adjustments section. • Contact an authorized service center.
Hard to start	<ul style="list-style-type: none"> • Dirty air filter. • Bad spark plug. • Weak or dead battery. • Dirty fuel filter. • Stale or dirty fuel. • Loose or damaged wiring. • Carburetor out of adjustment. • Engine valves out of adjustment. 	<ul style="list-style-type: none"> • Clean/replace air filter. • Replace spark plug. • Recharge or replace battery. • Replace fuel filter. • Drain fuel tank and refill with fresh gasoline. • Check all wiring. • See "To Adjust Carburetor" in Service and Adjustments section. • Contact an authorized service center.
Engine will not turn over	<ul style="list-style-type: none"> • Clutch/brake pedal not depressed. • Attachment clutch is engaged. • Weak or dead battery. • Blown fuse. • Corroded battery terminals. • Loose or damaged wiring. • Faulty ignition switch. • Faulty solenoid or starter. • Faulty operator presence switch(es). 	<ul style="list-style-type: none"> • Depress clutch/brake pedal. • Disengage attachment clutch. • Recharge or replace battery. • Replace fuse. • Clean battery terminals. • Check all wiring. • Check/replace ignition switch. • Check/replace solenoid or starter. • Contact an authorized service center.
Engine clicks but will not start	<ul style="list-style-type: none"> • Weak or dead battery. • Corroded battery terminals. 	<ul style="list-style-type: none"> • Recharge or replace battery. • Clean battery terminals.

TROUBLESHOOTING CHART

PROBLEM	CAUSE	CORRECTION
Engine clicks but will not start (con- t'd)	<ul style="list-style-type: none"> • Loose or damaged wiring. • Faulty solenoid or starter. 	<ul style="list-style-type: none"> • Check all wiring. • Check/replace solenoid or starter.
Loss of power	<ul style="list-style-type: none"> • Cutting too much grass/too fast. • Throttle in "CHOKE" position. • Build-up of grass, leaves and trash under mower. • Dirty air filter. • Low oil level/dirty oil. • Faulty spark plug. • Dirty fuel filter. • Stale or dirty fuel. • Water in fuel. • Spark plug wire loose. • Dirty engine air screen/fins. • Dirty/clogged muffler. • Loose or damaged wiring. • Carburetor out of adjustment. • Engine valves out of adjustment. 	<ul style="list-style-type: none"> • Set in "Higher Cut" position/reduce speed. • Adjust throttle control. • Clean underside of mower housing. • Clean/replace air filter. • Check oil level/change oil. • Clean and regap or change spark plug. • Replace fuel filter. • Drain fuel tank and refill with fresh gasoline. • Drain fuel tank and carburetor, refill tank with fresh gasoline and replace fuel filter. • Connect and tighten spark plug wire. • Clean engine air screen/fins. • Clean/replace muffler. • Check all wiring. • See "To Adjust Carburetor" in Service and Adjustments section. • Contact an authorized service center.
Excessive vibration	<ul style="list-style-type: none"> • Worn, bent or loose blade. • Bent blade mandrel. • Loose/damaged part(s). 	<ul style="list-style-type: none"> • Replace blade. Tighten blade bolt. • Replace blade mandrel. • Tighten loose part(s). Replace damaged parts.
Engine continues to run when operator leaves seat with attachment clutch engaged	<ul style="list-style-type: none"> • Faulty operator-safety presence control system. 	<ul style="list-style-type: none"> • Check wiring, switches and connections. If not corrected, contact an authorized service center.
Poor cut - uneven	<ul style="list-style-type: none"> • Worn, bent or loose blade. • Mower deck not level. • Buildup of grass, leaves, and trash under mower. • Bent blade mandrel. • Clogged mower deck vent holes from buildup of 	<ul style="list-style-type: none"> • Replace blade. Tighten blade bolt. • Level mower deck. • Clean underside of mower housing. • Replace blade mandrel. • Clean around mandrels to open vent holes.

TROUBLESHOOTING CHART

PROBLEM	CAUSE	CORRECTION
Poor cut - uneven (cont'd)	grass, leaves, and trash around mandrels.	
Mower blades will not rotate	<ul style="list-style-type: none"> • Obstruction in clutch mechanism. • Worn/damaged mower drive belt. • Frozen idler pulley. • Frozen blade mandrel. 	<ul style="list-style-type: none"> • Remove obstruction. • Replace mower drive belt. • Replace idler pulley. • Replace blade mandrel.
Poor grass discharge	<ul style="list-style-type: none"> • Engine speed too slow. • Travel speed too fast. • Wet grass. • Mower deck not level. • Low/uneven tire air pressure. • Worn, bent or loose blade. • Buildup of grass, leaves and trash under mower. • Mower drive belt worn. • Blades improperly installed. • Improper blades used. • Clogged mower deck vent holes from buildup of grass, leaves, and trash around mandrels. 	<ul style="list-style-type: none"> • Place throttle control in "FAST" position. • Shift to slower speed. • Allow grass to dry before mowing. • Level mower deck. • Check tires for proper air pressure. • Replace/sharpen blade. Tighten blade bolt. • Clean underside of mower housing. • Replace mower drive belt. • Reinstall blades sharp edge down. • Replace with blades listed in this manual. • Clean around mandrels to open vent holes.
Headlight(s) not working (if so equipped)	<ul style="list-style-type: none"> • Switch is "OFF". • Bulb(s) burned out. • Faulty light switch. • Loose or damaged wiring. • Blown fuse. 	<ul style="list-style-type: none"> • Turn switch "ON". • Replace bulb(s). • Check/replace light switch. • Check wiring and connections. • Replace fuse.
Battery will not charge	<ul style="list-style-type: none"> • Bad battery cell(s). • Poor cable connections. • Faulty regulator (if so equipped). • Faulty alternator. 	<ul style="list-style-type: none"> • Replace battery. • Check/clean all connections. • Replace regulator. • Replace alternator.
Engine "backfires" when turning engine "OFF"	<ul style="list-style-type: none"> • Engine throttle control not set at "SLOW" position for 30 seconds before stopping engine. 	<ul style="list-style-type: none"> • Move throttle control to "SLOW" position and allow to idle for 30 seconds before stopping engine.

TRACTOR -- MODEL NUMBER 917.270811

SCHEMATIC

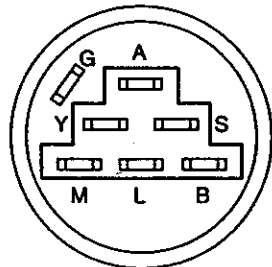
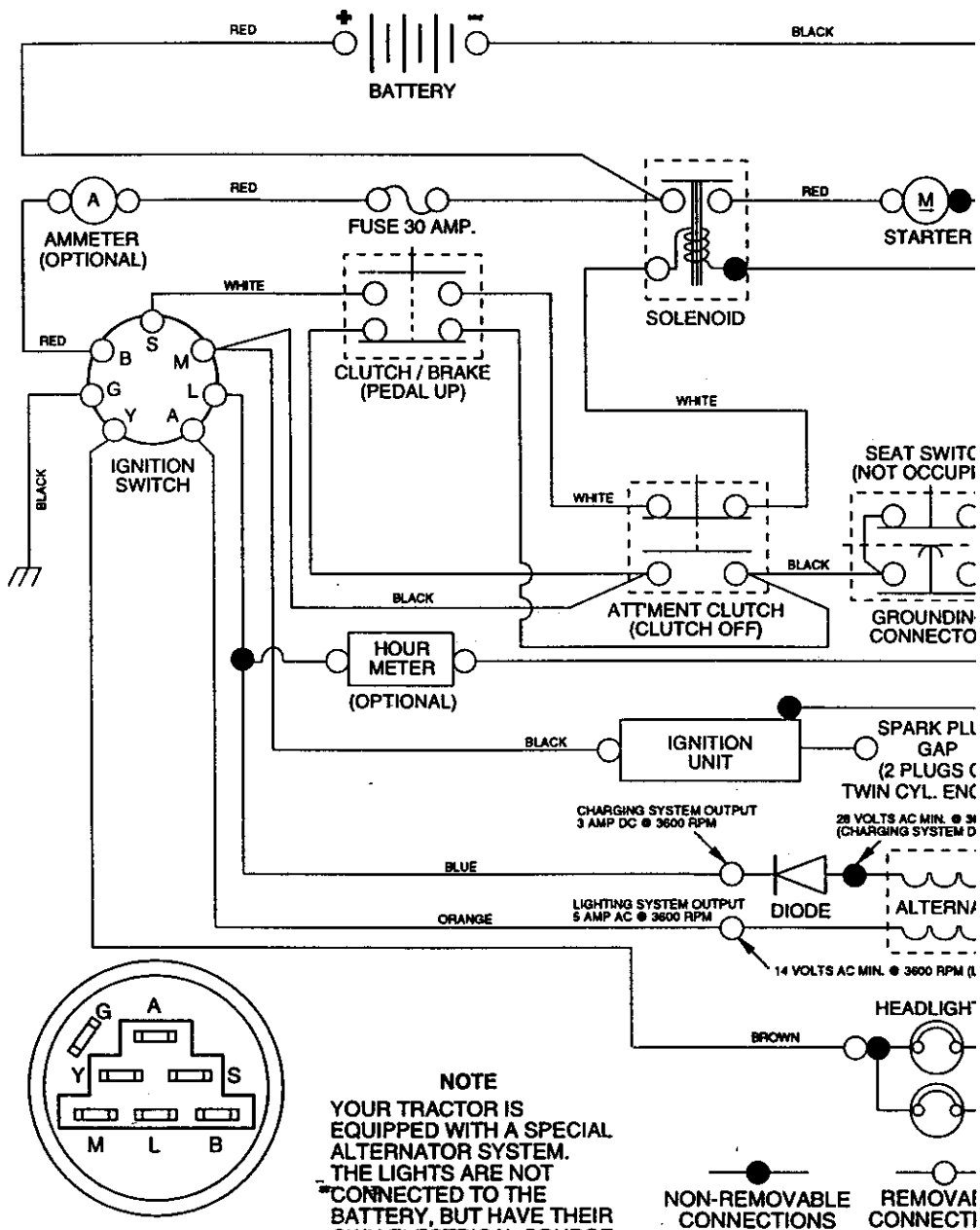

IGNITION SWITCH

POSITION	CIRCUIT	"MAKE"
OFF	G + M + L	NONE
RUN/LIGHT	B + L	A + Y
RUN	B + L	NONE
START	B + L + S	NONE

NOTE
 YOUR TRACTOR IS EQUIPPED WITH A SPECIAL ALTERNATOR SYSTEM. THE LIGHTS ARE NOT CONNECTED TO THE BATTERY, BUT HAVE THEIR OWN ELECTRICAL SOURCE. BECAUSE OF THIS, THE BRIGHTNESS OF THE LIGHTS WILL CHANGE WITH ENGINE SPEED. AT IDLE THE LIGHTS WILL DIM. AS THE ENGINE IS SPEEDED UP, THE LIGHTS WILL BECOME THEIR BRIGHTEST.

● NON-REMOVABLE CONNECTIONS
 ○ REMOVABLE CONNECTIONS

WIRING INSULATED CLIPS
NOTE: IF WIRING INSULATED CLIPS WERE REMOVED FOR SERVICING OF UNIT, THEY SHOULD BE REPLACED TO PROPERLY SECURE YOUR

REPAIR PARTS

TRACTOR -- MODEL NUMBER 917.270811

ELECTRICAL

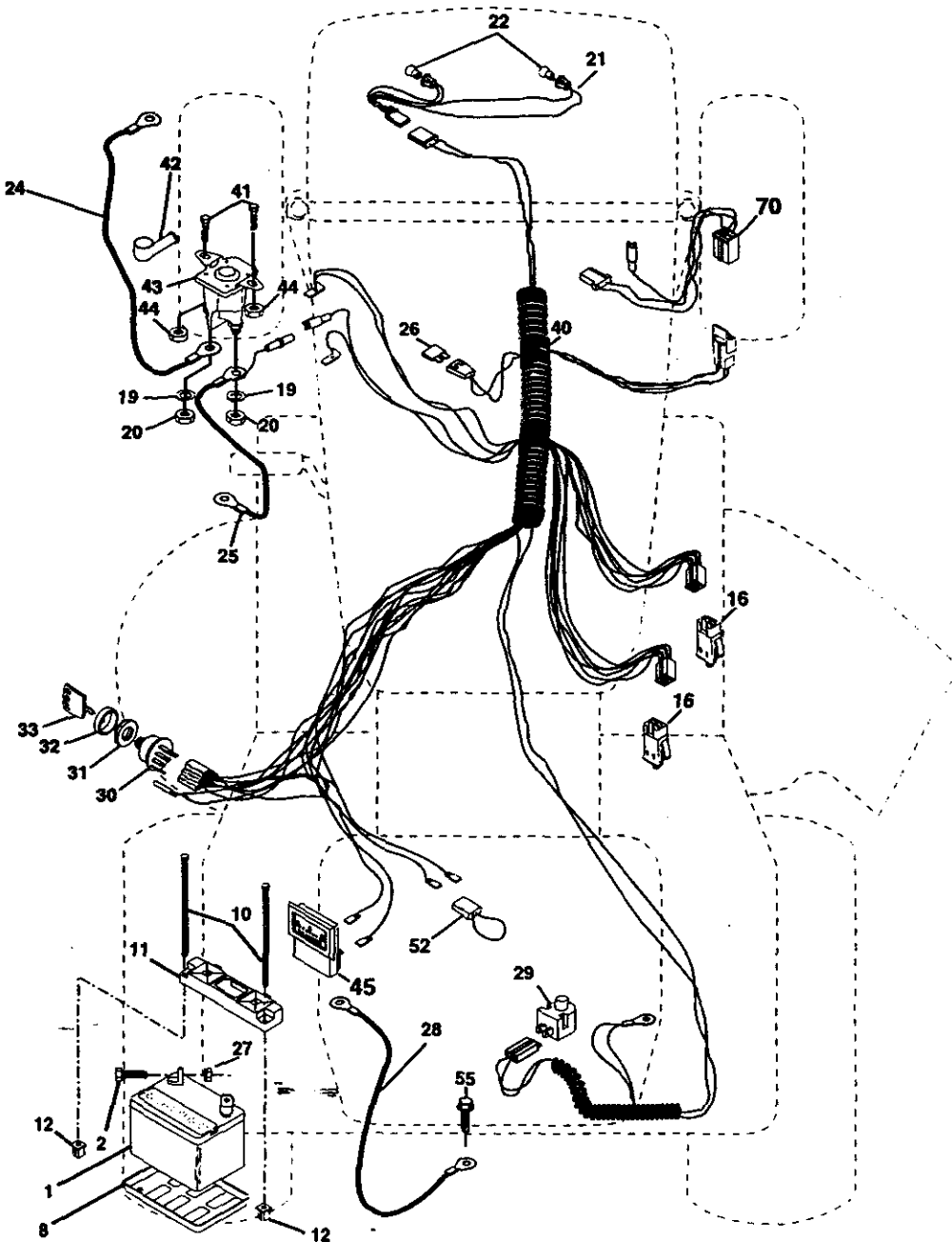

TRACTOR - - MODEL NUMBER 917.270811

ELECTRICAL

KEY NO.	PART NO.	DESCRIPTION
1	163465	Battery 12 VOLT 28 AMP
2	74760412	Bolt Hex Hd 1/4-20unc x 3/4
8	7603J	Case Battery
10	145211	Bolt, Btr Front 1/4-20 x 7-1/2
11	150109	Holddown Battery Front Mount
12	145769	Nut, Push Nylon Battery Front 1/4
16	153664	Switch, Interlock Push-In
19	Std551125	Washer Lock 1/4
20	73350400	Nut Jam Hex 1/4-20 Unc
21	147430	Harness Light Socket (W/4152j)
22	4152J	Bulb Light #1156
24	4799J	Cable Battery
25	146148	Cable Battery
26	108824X	Fuse
27	73510400	Nut Keps Hex 1/4-20 Unc
28	145491	Cable Ground
29	121305X	Switch Seat
30	140301	Switch Ign 4 Position
31	124211X	Nut Ignition
32	141226	Cover Ignition Switch
33	109310X	Key Molded Craftsman
40	156442	Harness Ign
41	71110408	Bolt Blk. Fin Hex 1/4-20 Unc x 1/2
42	131563	Cover Terminal
43	145673	Solenoid
44	73640400	Nut Keps Blk Hex 1/4-20 Unc
45	121433X	Ammeter Rectangular 6 Amp
52	141940	Protection Wire Loop
55	17490508	Screw Thdrol 5/16-18 x 1/2
70	140413	Harness Engine B&S 14 OHV

NOTE: All component dimensions give in U.S. inches
1 inch = 25.4 mm

TRACTOR -- MODEL NUMBER 917.270811

CHASSIS AND ENCLOSURES

KEY NO.	PART NO.	DESCRIPTION
1	160392	Chassis Assembly
2	140356	Drawbar
3	17490612	Screw, Thd. Roll. 3/8-16 x 1
4	STD551025	Washer 13/32 x 3/4 x 16 Gauge
5	155272	Bumper Hood/Dash
9	161917X013	Dash
10	STD533710	Bolt, Carriage 3/8-16 x 1
11	155927	Panel, Dash, L.H.
12	145660	Clip Tinnerman Grille P/L
13	155936	Panel, Dash, R.H.
14	17490608	Screw Thdrol 3/8-16 x 1/2
17	144983X558	Hood Assembly
18	126938X	Bumper Hood
20	156437	Plate Mtg Battery Fuel Tank
23	124028X	Bushing, Snap, Nylon, Fuel Line
25	19131312	Washer 13/32 x 13/16 x 12 Gauge
26	STD541437	Locknut, Hex, with Insert 3/8-16 Unc
28	145198X558	Grille w/Clips MS-558
29	155217X599	Lens, Grille
30	151287X558	Fend/Ftrest
31	139976	Bracket, Fender Support
37	17490508	Screw Thdrol 5/16-18 x 1/2
38	139886	Pivot Bracket Assembly, L.H.
39	139887	Pivot Bracket Assembly, R.H.
51	73800400	Nut Lock w/Insert 1/4-20 UNC
52	19091416	Washer 9/32 x 7/8 x 16 Ga.
53	145201	Bracket Grille Pickoff LH
54	161464	Screw Hex Wshd 8-18 x 7/8
55	145202	Bracket Grille Pickoff RH
57	STD522507	Bolt, Fin Hex 1/4-20 UNC x .75
58	140547	Air Duct P/L 18HP B&S Opp. Twin
60	STD533707	Bolt Rdhd Sqnk 3/8-16 UNC x 3/4
64	154798	Dash Lower STLT
74	STD541437	Nut Crownlock 3/8-16 UNC
114	158112	Keeper Belt Rear Lh Stl
115	17490620	Screw Thrdol 3/8-16 x 1-1/4
116	19131614	Washer 13/32 x 1 x 14 Ga.
140	158418	Bracket Suspension Front
142	165867	Plate Reinforcement STLT
143	154966	Bracket Swaybar Chassis
144	154207	Bracket Pnt Footrest STLT
145	156524	Rod Pivot Chassis/Hood

NOTE: All component dimensions give in U.S. inches
1 inch = 25.4 mm

TRACTOR -- MODEL NUMBER 917.270811

GROUND DRIVE

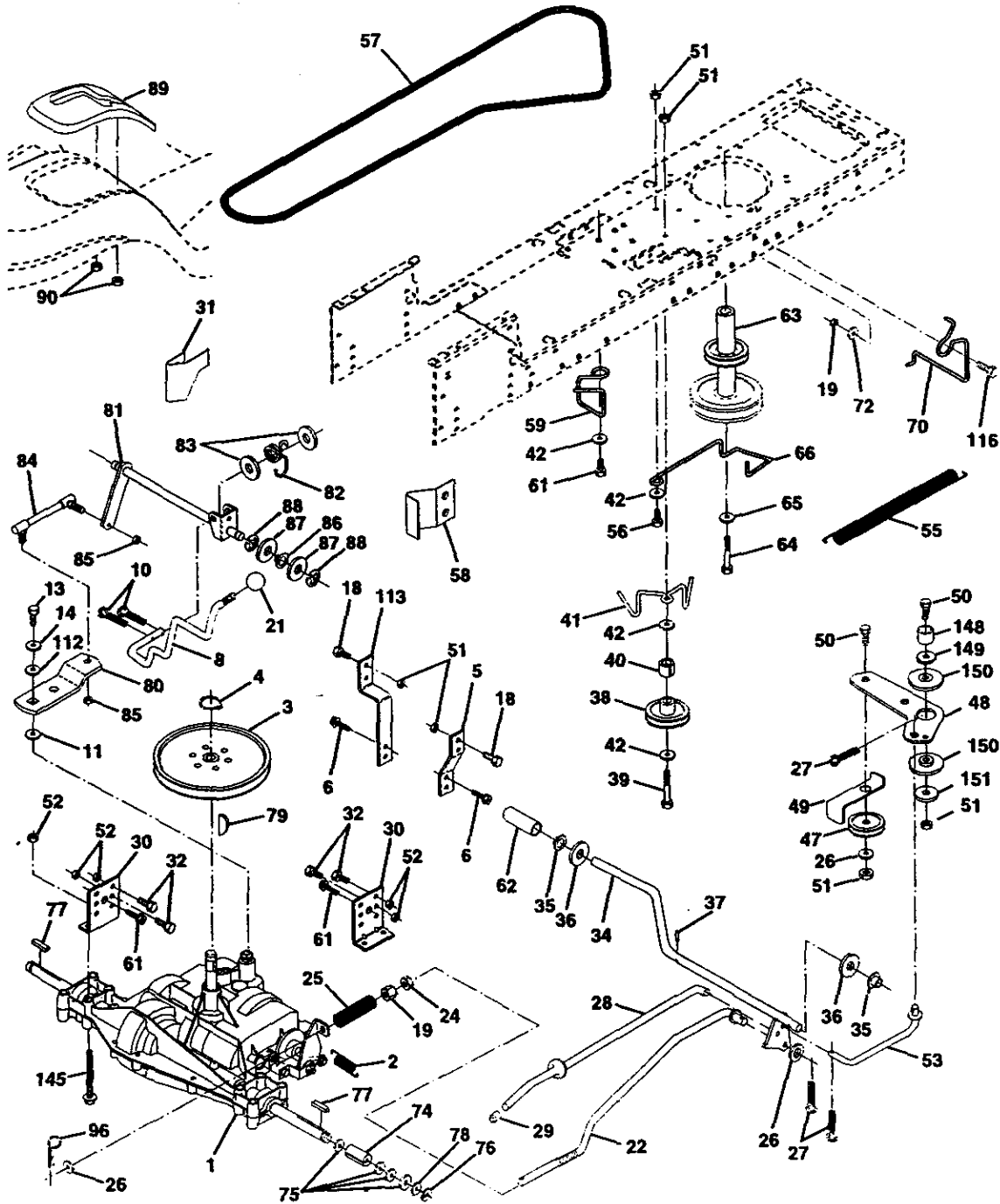

TRACTOR - - MODEL NUMBER 917.270811

GROUND DRIVE

KEY NO.	PART NO.	DESCRIPTION	KEY NO.	PART NO.	DESCRIPTION
1	-----	Transaxle (See Breakdown) Peerless 206-545C	56	STD523712	Bolt Fin Hex 3/8-16 x 1-1/4
2	146682	Spring, Return, Brake	57	130807	V-Belt, Ground Drive
3	123666X	Pulley, Transaxle	58	127274X	Keeper, Belt, R.H.
4	12000028	Ring, Retainer	59	140312	Keeper, Belt, Center Span
5	121520X	Strap, Torque	61	17490612	Screw, Thd., Roll. 3/8-16 x 3/4
6	17490512	Screw, Thd., Roll. 5/16-18 x 3/4	62	8883R	Cover, Pedal
8	154792	Rod Shifter Fender STLT	63	140186	Pulley, Engine
10	STD561210	Pin, Cotter	64	71170764	Bolt, Hex Head, Fin. 7/16-20 x 4 Grade 5
11	105701X	Washer, Shift Plate	65	STD551143	Washer
13	74550412	Bolt 1/4-28 UNF W/Patch Gr. 8	66	154778	Keeper, Belt, Engine, Fool- Proof
14	STD551125	Washer	70	134683	Guide, Mower Drive Belt, R.H.
18	STD523710	Bolt Fin Hex 3/8-16 UNC x 1. Gr 5	72	19132012	Washer 13/32 x 1-1/4 x 12 Ga.
19	STD541437	Nut	74	137057	Spacer, Axle
21	106933X	Knob	75	121749X	Washer 25/32 x 1-1/4 x 16 Ga.
22	130804	Rod, Brake	76	STD581075	E-Ring
24	STD541237	Nut	77	123583X	Key, Square 2.0 x .1845/.1865
25	106888X	Spring, Brake Rod	78	121748X	Washer 25/32 x 1-5/8 x 16 Gauge
26	STD551037	Washer	79	STD580025	Key Woodruff
27	STD561210	Pin	80	145090	Arm, Shift
28	145204	Rod, Parking Brake	81	161082	Shaft Assembly
29	124236X	Cap, Parking Brake, Red	82	123782X	Spring, Torsion
30	130807	Bracket, Transaxle	83	19171216	Washer 17/32 x 3/4 x 16 Ga.
31	127275X	Keeper, Belt, L.H.	84	145643	Tie Rod
32	STD523107	Bolt	85	150360	Nut, Nylock
34	155071	Shaft Assembly, Foot Pedal	86	157480	Bushing
35	120183X	Bearing, Nylon	87	19212016	Washer
36	STD551062	Washer	88	12000008	E-Ring
37	STD571810	Roll Pin	89	158391X428	Console, Shift, STLT
38	131494	Pulley, Idler, Flat	90	124346X	Nut, Self-Thdng, Wsh Hd 1/4
39	STD523727	Bolt	96	STD624003	Retainer Spring 1"
40	4470J	Spacer, Split .395 x .59	112	19091210	Washer 9/32 x 3/4 x 10 Gauge
41	165838	Keeper, Belt, Idler	113	127285X	Strap Torque 90 Degrees
42	19131312	Washer 13/32 x 13/16 x 12 Ga.	116	72110610	Bolt Rdhd Sqneck 3/8-16 x 1.25
47	127783	Pulley, Idler, V-Groove, Plastic	145	74490540	Bolt, Hex Fighd 5/16-18 Gr. 5
48	154407	Bellcrank Clutch Gmd Drv Stl	148	159103	Spacer
49	123205X	Retainer, Belt	149	122052X	Spacer Retainer PM Mower
50	STD523715	Bolt	150	150935	Bushing Nylon Collered
51	STD541437	Nut Crown Lock 3/8-16 UNC	151	19133210	Washer 13/32 x 2 x 10 Ga.
52	STD541431	Nut Crown Lock 5/16-18 UNC			
53	105710X	Link, Clutch			
55	105709X	Spring, Clutch Return			

NOTE: All component dimensions give in U.S. inches 1 inch = 25.4 mm

TRACTOR - - MODEL NUMBER 917.270811

STEERING ASSEMBLY

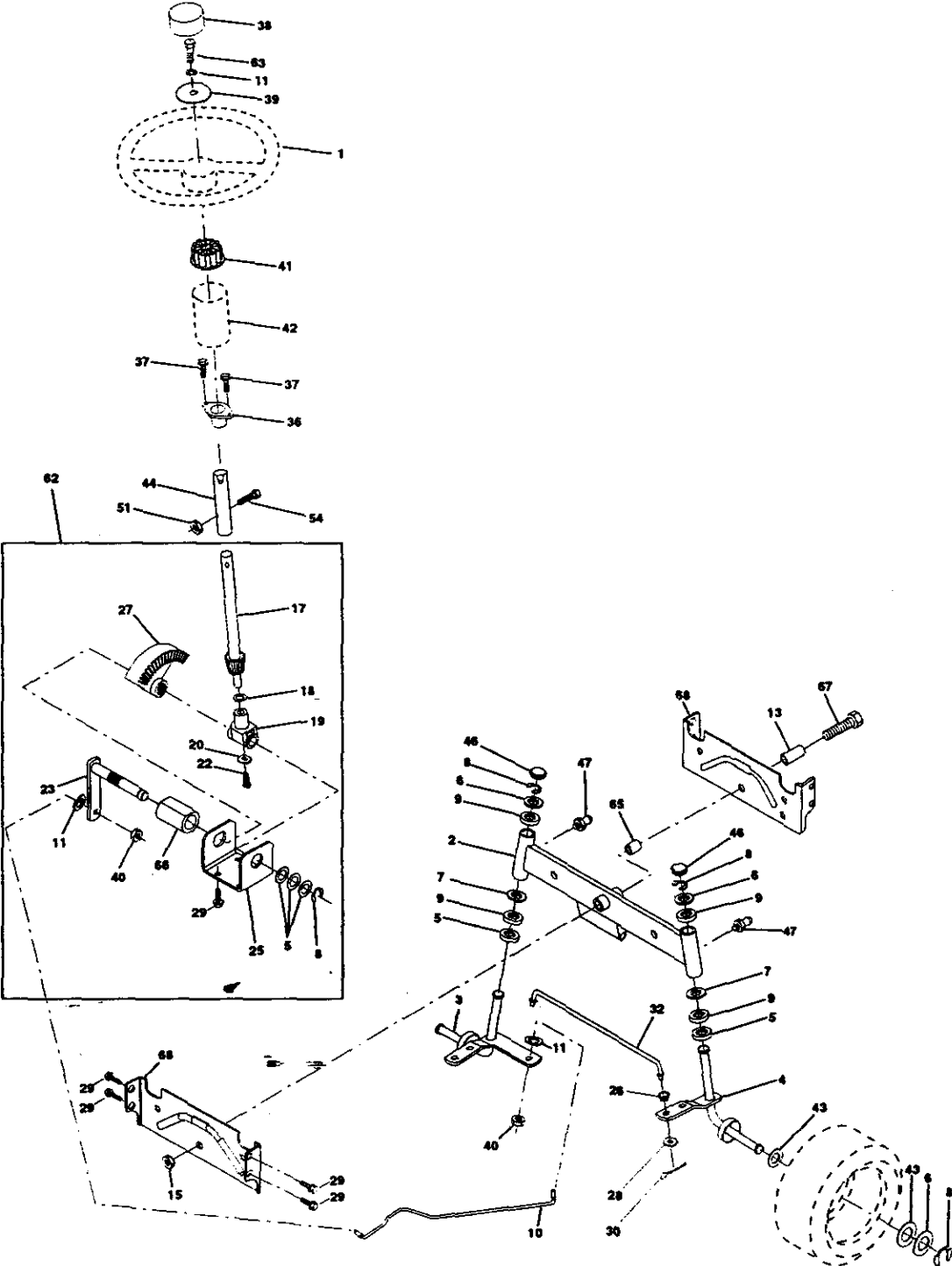

TRACTOR - - MODEL NUMBER 917.270811

STEERING ASSEMBLY

KEY NO.	PART NO.	DESCRIPTION
1	139768	Steering Wheel
2	154427	Axle Assembly STMP Dropped STL
3	156483	Spindle Assembly, L.H.
4	157473	Spindle Assembly, R.H.
5	6266H	Bearing, Race, Thrust, Hardened
6	121748X	Washer 25/32 x 1-5/8 x 16 Gauge
7	19272016	Washer 27/32 x 1-1/4 x 16 Gauge
8	12000029	Ring, Klip
9	3366R	Bearing, Steering Column
10	156438	Draglink Extended Stamped
11	STD551137	Washer, Lock
13	154779	Bearing Axle STL/GT
15	73901000	Nut, Lock, Flange 5/8-11 UNC
17	156546	Shaft Assembly, Steering
18	57079	Washer, Thrust .515 x .750 x .033
19	124035X	Support, Shaft
20	126684X	Washer, Shim 1/4 x 5/8 x .062
22	71200410	Screw, Hex Socket 1/4-20 x 5/8
23	127501	Pittman Shaft Assembly
25	154406	Bracket, Steering
26	126847X	Bushing, Link, Drag
27	136874	Gear, Sector
28	19131416	Washer 13/32 x 7/8 x 16 Gauge
29	17490612	Screw, Thd., Roll. 3/8-16 x 3/4
30	STD561210	Pin
32	130465	Rod, Tie
36	155099	Bushing, Steering
37	152927	Screw
38	139769	Insert, Steering Wheel
39	19133808	Washer 13/32 x 2-3/8 x 8 Gauge
40	STD541537	Gripco Nut
41	100711L	Adaptor, Steering Wheel
42	145054	Boot, Steering Shaft
43	121749X	Washer 25/32 x 1-1/4 x 16 Gauge
44	153720	Extension Shaft Steering LR.LT
46	121232X	Cap, Spindle
47	6855M	Fitting, Grease
51	STD541431	Nut Lock Hex w/Ins. 5/16-18 UNC
54	74780520	Bolt Fin Hex 5/16-18 UNC x 1-1/4
62	156594	Kit Steering Asm Service
63	STD528710	Bolt, Fin Hex 3/8-16 UNC x 1 Gr 5
65	154780	Spacer Axle
66	154404	Bearing Arm Pittman
67	74781044	Bolt, Fin Hex 5/8-11 UNC x 2-3/4
68	154429	Axle, Brace

NOTE: All component dimensions given in U.S. inches
1 inch = 25.4 mm

TRACTOR -- MODEL NUMBER 917.270811

ENGINE

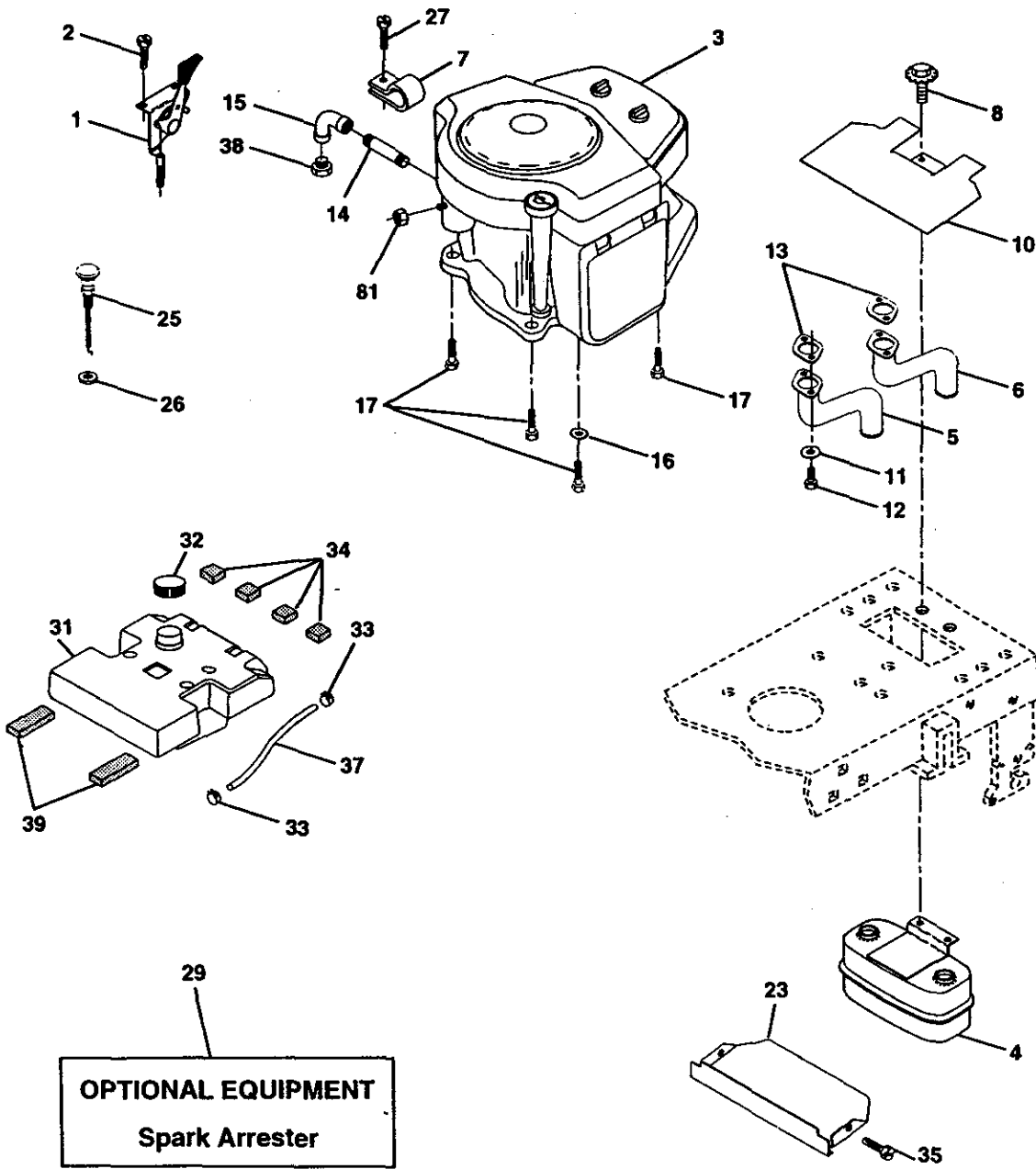

TRACTOR -- MODEL NUMBER 917.270811

ENGINE

KEY NO.	PART NO.	DESCRIPTION
1	162152	Control, Throt Paddle 32 22
2	17720410	Screw, Hex Thd Cut 1/4-20 x 5/8
3	-----	Engine, B&S, (See Breakdown) No. 42E707-2631-E1
4	149723	Muffler Exhaust
5	144069	Exhaust Asm. Left
6	144068	Exhaust Asm. Right
7	138129	Clamp Tube Double Engine
8	150176	Bolt 5/16-18unc x 3/4 W/Sems
10	145552	Heat Shield Lt
11	STD551125	Washer Lock Hvy. Helical 1/4
12	STD522507	Bolt Fin Hex 1/4-20Unc x .75
13	165287	Gasket, Muffler
14	13280336	Nipple, Pipe 4-1/2
15	13200300	Elbow, Standard 90°, 3/8-18 NPT
16	STD551237	Washer Lock Ext Tooth 3/8
17	17490624	Screw Thdrol 3/8-16x1-1/2 Tytt
23	159880	Shield, Brv/Db Guard
25	145996	Control Choke
26	73920600	Nut Keps 3/8-24 Unf
27	152927	Screw TT #10-32 x 5 x 3/8 Flange
29	137180	Arrestor, Spark
31	157103	Tank, Fuel
32	161696	Cap Fuel Guage
33	123487X	Clamp, Hose
34	106082X	Spacer Pad
35	17490512	Screw Thdrol 5/16-18 x 3-4 Tyt
37	8543R	Line, Fuel
38	-----	Plug, Oil Drain (Order From Engine Manufacturer)
39	109227X	Pad Idler
81	128861	Nut Flange 1/4-20 Starter Nut

NOTE: All component dimensions given in U.S. inches

1 inch = 25.4 mm

TRACTOR -- MODEL NUMBER 917.270811

SEAT ASSEMBLY

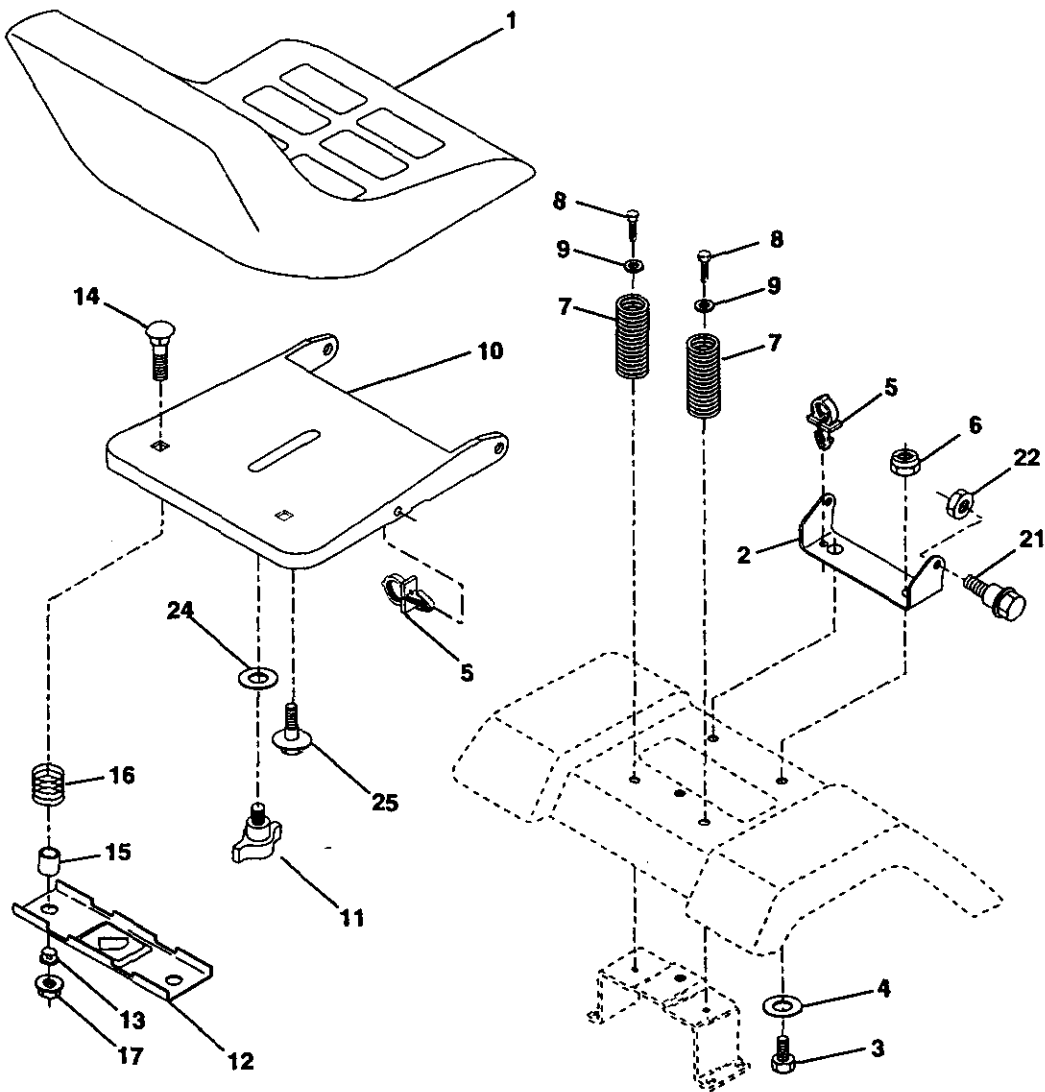

KEY NO.	PART NO.	DESCRIPTION
1	140123	Seat 3350 Blk/blk Craftsman
2	140551	Bracket Pnt Pivot Seat (blk)
3	STD523710	Bolt Fin Hex 3/8-16unc X 1
4	19131610	Washer 13/32 X 3/4 X 10 Ga
5	145006	Clip Push In Hinged
6	STD541437	Nut Hex Lock w/ins 3/8-16 Unc
7	124181X	Spring Seat Cprsn 2 250 Blk Zi
8	17490616	Screw Thdrol 3/8-16 X 1 Ty-tt
9	19131614	Washer 13/32 X 1 X 14 Ga
10	155925	Pan Pnt Seat (blk)
11	120068X	Knob Seat 1/2-13 Unc Blk
12	121246X	• Bracket Pnt Mounting Switch

KEY NO.	PART NO.	DESCRIPTION
13	121248X	Bushing Snap Blk Nyl 50 Id
14	72050412	Bolt Rdhd Sht Nk 1/4-20x1-1/2
15	134300	Spacer Split 28 X 96 Zinc
16	121250X	Spring Cprsn 1 27 Blk Pnt
17	123976X	Nut Lock 1/4 Lge Fig Gr 5 Zinc
21	153236	Bolt Shoulder 5/16-18 Unc-2A
22	STD541431	Nut Hex Lock w/ins 5/16-18
24	19171912	Washer 17/32 X 1-3/16 X 12 Ga.
25	127018X	Bolt Shoulder 5/16-18 X 62

NOTE: All component dimensions given in U.S. inches
1 inch = 25.4 mm

TRACTOR -- MODEL NUMBER 917.270811

DECALS

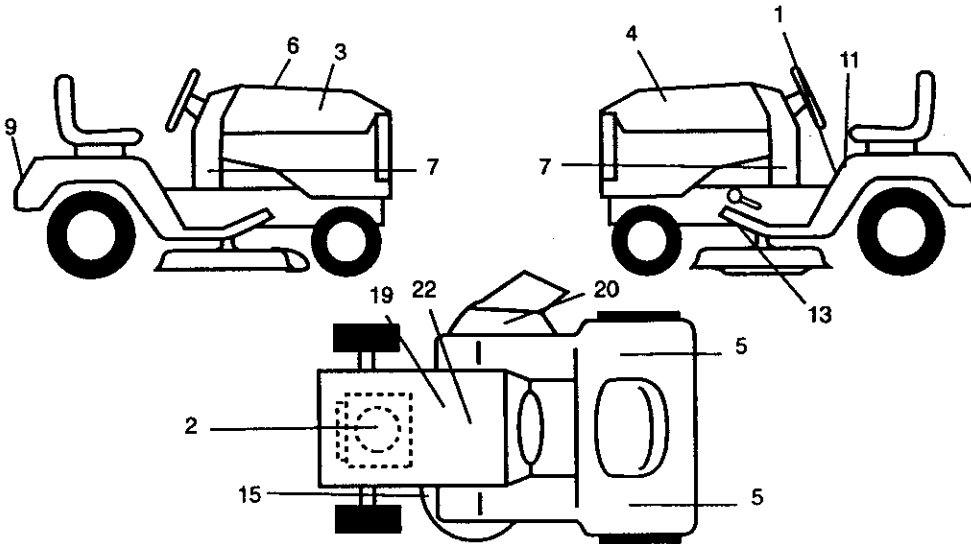

KEY NO.	PART NO.	DESCRIPTION	KEY NO.	PART NO.	DESCRIPTION
1	156439	Decal, Fender Danger Sears	13	146046	Decal, V-Belt Dr Sch Tractor
2	165392	Decal, Engine B&S	15	160396	Decal, Mower Drive Schematic
3	163200	Decal, Hood, R.H. Craftsman	19	138047	Decal, Battery Diehard Sears
4	163202	Decal, Hood, L.H. Craftsman	20	163203	Decal, Deck Mower EZ3 Mulching
5	163207	Decal, Fender SD. Wht. Rad/6Sp 42"	22	149516	Decal, Battery
6	133644	Decal, Maintenance	--	138311	Decal, Lift Handle
7	163259	Decal, Panel Dash B&S 19.5 Turbo	--	154515	Pad Footrest LH STLT
9	163204	Decal, Fender, Craftsman Gold	--	154516	Pad Footrest RH STLT
11	156368	Decal, Fender STLT Oper Inst E/S	--	167659	Owner's Manual, English
			--	167660	Owner's Manual, Spanish

WHEELS & TIRES

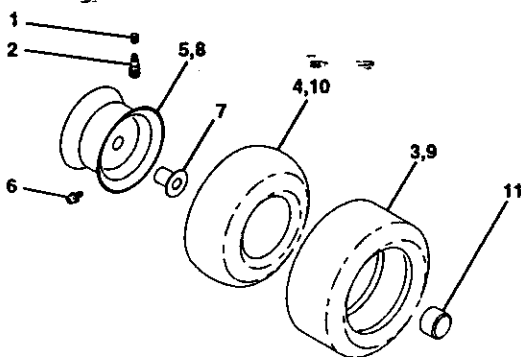

KEY NO.	PART NO.	DESCRIPTION
1	59192	Valve Cap, Tire
2	65139	Stem, Valve
3	106222X	Tire, Front
4	59904	Tube, Front Tire (Not Provided, Service Item Only)
5	106732X427	Rim, Front
6	278H	Fitting, Grease (Front Wheel Only)
7	9040H	Bearing, Flange (Front Wheel Only)
8	106108X427	Rim, Rear
9	122082X	Tire, Rear
10	7152J	Tube, Rear Tire (Not Provided, Service Item Only)
11	104757X	Cap, Axle
--	144334	Sealant, Tire 10 oz.

NOTE: All component dimensions given in U.S. inches
1 inch = 25.4 mm

TRACTOR -- MODEL NUMBER 917.270811

LIFT ASSEMBLY

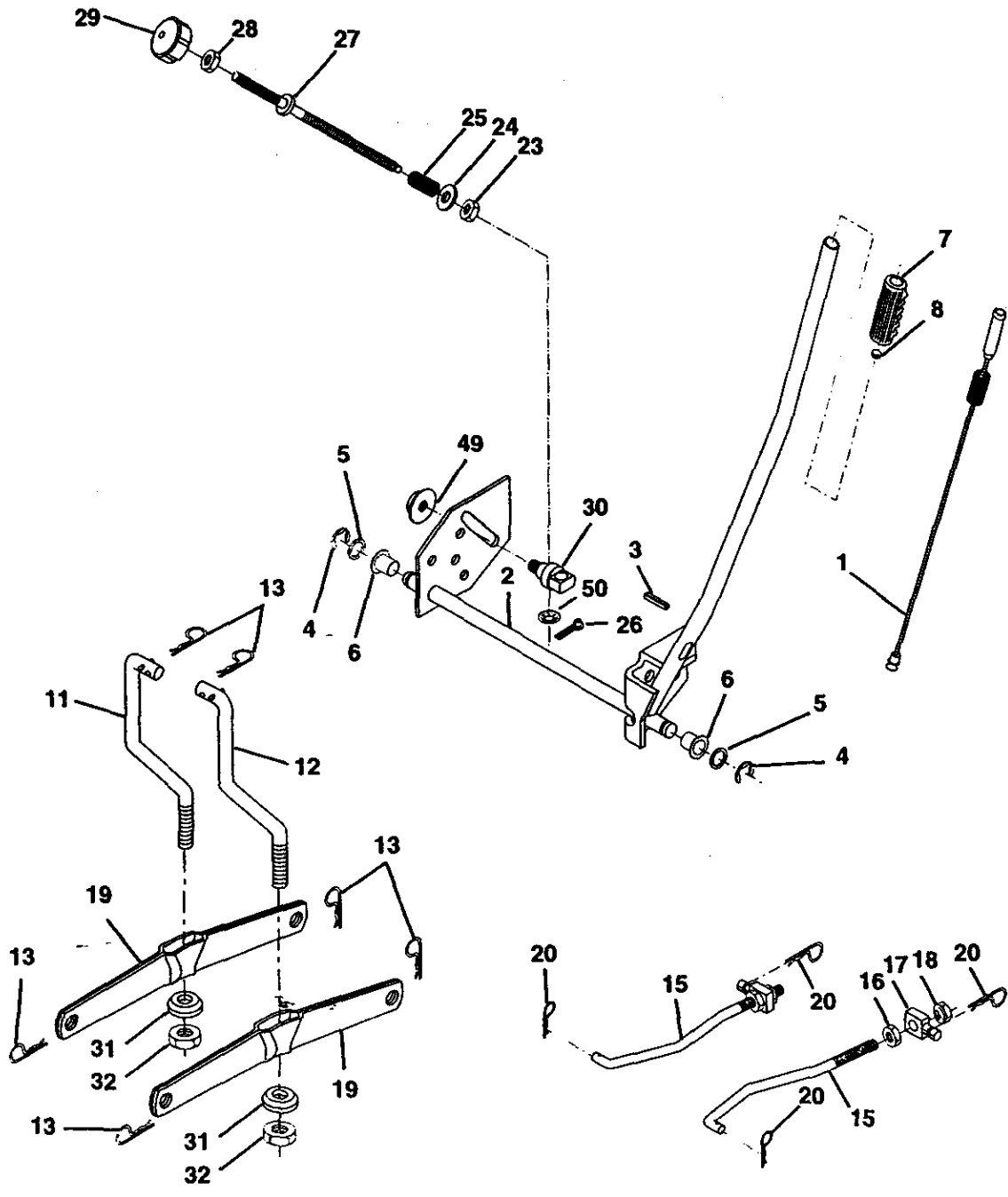

TRACTOR - - MODEL NUMBER 917.270811

LIFT ASSEMBLY

KEY NO.	PART NO.	DESCRIPTION
1	159460	Lift Lever Inner Wire Assembly
2	159471	Shaft Assembly, Lift
3	105767X	Pin, Groove
4	12000002	E-Ring
5	19211621	Washer 21/32 x 1 x 21 Gauge
6	120183X	Bearing, Nylon
7	125631X	Grip, Handle, Fluted
8	122365X	Button, Plunger, Red
11	139865	Link, Lift, L.H.
12	139866	Link, Lift, R.H.
13	STD624008	Retainer Spring
15	127218	Link, Front
16	73350800	Nut, Hex, Jam 1/2-13 UNC
17	130171	Trunnion
18	73680800	Nut Lock 1/2-13 UNC
19	139868	Arm, Suspension, Rear
20	163552	Retainer Spring
23	110807X	Nut, Special
24	19131016	Washer 13/32 x 5/8 x 16 Gauge
25	2876H	Spring
26	76020308	Pin, Cotter 3/32 x 1/2
27	126971X	Rod, Adjust, Lift
28	73350600	Nut, Hex, Jam 3/8-16 UNC
29	138057	Knob, Inf. 3/8-16
30	150233	Trunnion, Inf Height
31	140302	Bearing, Pvt, Lift Special
32	73540600	Nut, Crownlock 3/8-24
49	145212	Nut Flange Lock
50	110452X	Nut Push Phos & Oil

NOTE: All component dimensions given in U.S. inches
1 inch = 25.4 mm

TRACTOR -- MODEL NUMBER 917.270811

MOWER DECK

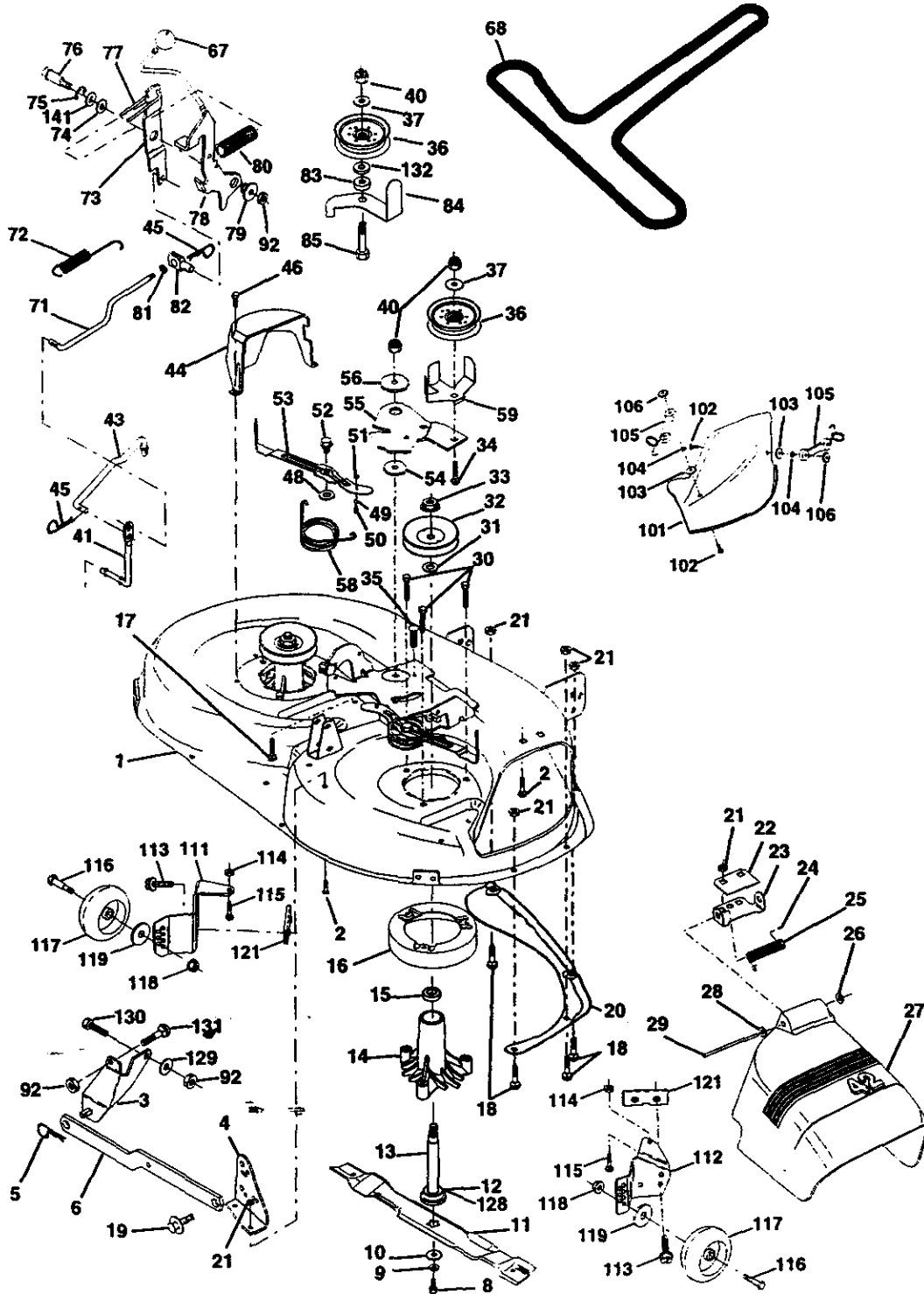

TRACTOR - - MODEL NUMBER 917.270811

MOWER DECK

KEY NO.	PART NO.	DESCRIPTION	KEY NO.	PART NO.	DESCRIPTION
1	164961	Mower Deck Assembly, 42"	56	122052X	Spacer, Retainer
2	STD533107	Bolt	58	140086	Spring, Torsion Brakes
3	138017	Bracket Assembly, Sway Bar, Front	59	141043	Guard, TUV Idler
4	138440	Bracket Assembly, Sway Bar	67	162113	Knob Custom Oval
5	STD624008	Retainer Spring	68	144200	V-Belt
6	130832	Arm, Suspension, Rear	71	142427	Rod, Clutch, Primary, with Nibs
8	850857	Bolt, Hex 3/8-24 x 1.25 Grade 8	72	131870	Spring, Return
9	STD551137	Washer, Lock	73	127847	Arm, Clutch, Secondary
10	140296	Washer, Hardened	74	121748X	Washer 25/32 x 1-5/8 x 16 Gauge
11	134149	Blade, Mulching	75	12000029	Ring, Klip
12	129895	Bearing, Ball	76	128903	Bolt, Shoulder 3/8-16 UNC x 1.44
13	137645	Shaft Assembly, Mandrel, Vented (Includes Key Number 12)	77	127845	Keeper, Spring
14	128774	Housing, Mandrel, Vented	78	160570	Lever Asm. Clutch Pri Pim STLT
15	110485X	Bearing, Ball, Mandrel	79	127498	Bushing, Large, Brass
16	140329	Stripper, Vented Mower Deck	80	153701	Spring, Mower Clutch
17	72110610	Bolt, Carriage 3/8-16 x 1-1/4	81	73350600	Nut, Hex Jam 3/8-16 Unc
18	72140505	Bolt, Carriage 5/16-18 x 5/8	82	142028	Trunnion, Adj.
19	132827	Bolt, Shoulder	83	120958X	Washer Sintered
20	159770	Baffle, Vortex	84	156084	Keeper Belt Idler
21	STD541431	Nut Crownlock 5/16-18 UNC	85	72140620	Bolt Carriage 3/8-16 x 2-1/2
22	134753	Stiffener Bracket	92	STD541437	Nut
23	131267	Bracket, Deflector	101	136420	Mulcher Cover
24	105304X	Cap, Sleeve	102	71161010	Screw
25	123713X	Spring, Torsion, Deflector	103	19061216	Washer #10
26	110452X	Nut, Push	104	STD551110	Washer, Lock
27	130968	Shield, Deflector	105	160793	Latch Assembly, Bagger
28	19111016	Washer 11/32 x 5/8 x 16 Gauge	106	2029J	Nut, Weld
29	131491	Rod, Hinge	111	155197	Bracket, Gauge, Wheel L.H.
30	157722	Screw Thdrol Washer Head	112	155198	Bracket, Gauge, Wheel R.H.
31	129963	Washer, Spacer	113	17490512	Screw Thdrol 5/16-18 x 3/4
32	153535	Pulley, Mandrel	114	STD541431	Nut, Hex, Keps 5/16-18 UNC
33	137266	Nut, Toplock, Flanged	115	72110504	Bolt, Carriage 5/16 UNC x 1/2
34	STD533717	Bolt	116	137644	Bolt, Shoulder
35	133835	Fastner, Christmas Tree	117	133957	Wheel, Gauge
36	131494	Pulley, Idler, Flat	118	73930600	Nut, Centerlock 3/8-16
37	STD551037	Washer 13/32 x 13/16 x 16 Gauge	119	STD551037	Washer 3/8 x 7/8 x 14 Gauge
40	STD541437	Nut Crownlock 3/8-16 UNC	121	143723	Bracket
41	133551	Rod, Pivot, with Nibs	128	153390	Washer Felt
43	140083	Rod, Clutch, Secondary, with Nibs	129	19131312	Washer 13/32 x 13/16 x 12 Ga.
44	140088	Guard, Mandrel, L.H.	130	STD523710	Bolt, Fin Hex 3/8-16 UNC x 1 Gr. 5
45	STD624003	Retainer	131	STD533710	Bolt, RDHD SQNK 3/8-16 UNC x 1
46	137729	Screw, Thd. Roll 1/4-20 x 5/8	132	19132203	Spacer Washer 13/32 I.D. x 1-3/8 O.D. x 1/4
48	133944	Washer, Hardened	141	6266H	Washer Thrust .75 x 1.230
49	155066	Roller Assembly, Cam Follower	--	130794	Mandrel Assembly (Includes Key Numbers 8-10, 12-15, 31 and 32)
50	131340	Bolt, Shoulder #10-24 Grade 5	--	164963	Mower Deck, Complete (Standard Deck, Order Separately Mulcher Plate and Gauge Wheel Components, Key Nos. 101-106 and 111-121)
51	STD541410	Locknut			
52	139888	Bolt, Shoulder 5/16-18 UNC			
53	131845	Arm Assembly, Pad, Brake			
54	133943	Washer, Hardened			
55	155046	Arm, Idler			

NOTE: All component dimensions given in U.S.inches
1 inch = 25.4 mm

TRACTOR -- MODEL NUMBER 917.270811
PEERLESS TRANSAXLE--MODEL NUMBER 206-545C

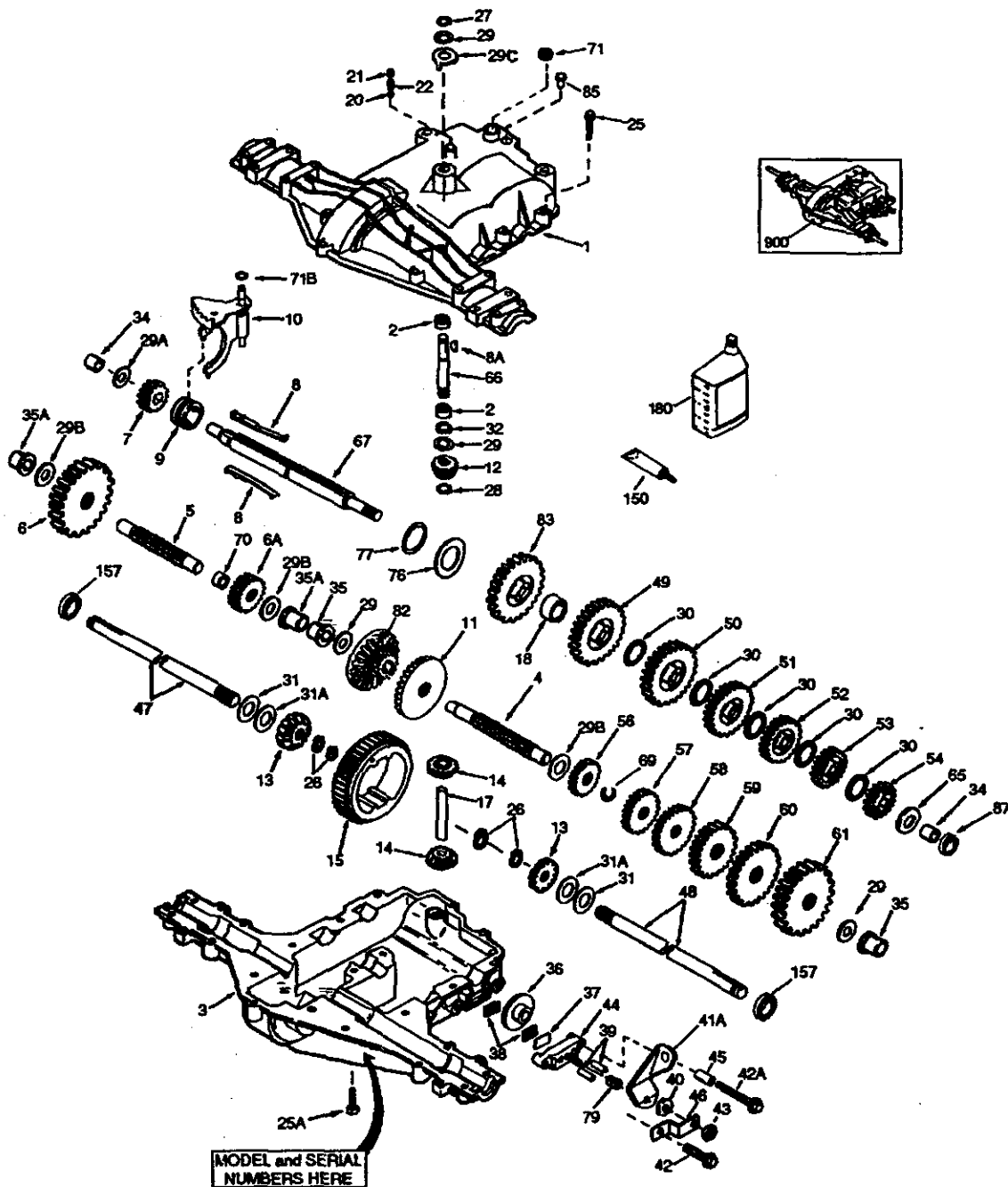

TRACTOR - - MODEL NUMBER 917.270811

PEERLESS TRANSAXLE--MODEL NUMBER 206-545C

REF NO.	PART NO.	DESCRIPTION	REF NO.	PART NO.	DESCRIPTION
1	772147	Transaxle Cover	41A	790079	Brake Lever
2	780086A	Needle Bearing 5/8"	42	792073A	Screw 1/4 - 20 x 1-1 /4"
3	770128	Transaxle Case	42A	792085A	Screw 1/4 - 20 x 2 1/4"
4	776395	Countershaft	43	792075	Locknut 5 / 16 - 24
5	776409	Output Shaft	44	790025	Brake Pad Holder
6	778364	Spur Gear (38 teeth)	45	786066	Spacer .2625 x 1.0
6A	778369	Spur Gear (15 teeth)	46	786086	Brake Lever Bracket
7	778330	Spur Gear (11 teeth)	47	774690	Axle (11-15 / 16" Long)
8	792180	Shift Key	48	774691	Axle (16 - 1 / 2" long)
8A	792047	Woodruff Key #9	49	778356	Spur Gear (29 teeth)
9	784352	Shift Collar	50	778338	Spur Gear (27 teeth)
10	784378	Shift Rod & Fork	51	778354	Spur Gear (23 teeth)
11	778334	Bevel Gear (30 teeth)	52	778352	Spur Gear (19 teeth)
12	778309	Input Bevel Pinion (13 teeth)	53	778350	Spur Gear (16 teeth)
13	778368	Bevel Gear (13 teeth) (Include. 14)	54	778346	Spur Gear (15 teeth)
14	778368	Bevel Pinion (13 teeth) (Include. 13)	56	778355	Spur Gear (11 teeth)
15	778370	Ring Gear (43 teeth)	57	778337	Spur Gear (13 teeth)
17	786188	Drive Pin	58	778353	Spur Gear (17 teeth)
18	786102	Spacer 1.130 X .695	59	778351	Spur Gear (21 teeth)
20	792077A	Ball 5/16" dia	60	778349	Spur Gear (24 teeth)
21	792078	Set Screw 3/8 - 16 x 3/8"	61	778345	Spur Gear (25 teeth)
22	792079	Spring .310 OD x .625 L	65	780189	Flat Washer .563 ID x .062W
25	792073A	Screw 1/4 - 20 x 1-1/4"	66	776422	Input Shaft
25A	792177	Screw 1/4-20 x 1-3/8"	67	776396	Shifter & Brake Shaft
26	792125	Retaining Ring (pkg of 2)	69	792170	Retaining Ring
27	792035	Retaining Ring	70	786187	Spacer .890
28	788040	Retaining Ring	71	788069	Square Cut Ring
29	780072	Thrust Washer .627 ID x .031W	71B	788092	"O" Ring
29A	780160	Thrust Washer .762 ID x .031W	76	780090	Flat Washer 1.128 ID x .058W
29B	780051	Thrust Washer .762 ID x .031W	77	788078A	Inverted Retaining Ring
29C	780199	Anti-Rotation Washer .632	79	792144	Spring .430 OD x .5000 L
30	780108	Cup Washer 1.127 ID x .032W	82	778333	Bevel & Spur Gear (30 & 13 teeth)
31	780001	Flat Washer .750 ID x .056W (Use As Needed)	83	778338	Spur Gear (27 teeth)
31A	780195	Flat Washer .750 ID x .062W	85	792154	Oil Fill Plug
32	788083	Oil Seal 5/8"	87	788089A	Oil Seal 9 / 16"
34	780194	Bushing .563	150	788093A	Liquid Gasket RTV Silicone
35	780193	Flanged Bushing 5 / 8" ID	157	788088A	Oil Seal 3 / 4"
35A	780197	Flanged Bushing .751	180	730229A	Gear Oil 80W90
36	790075	Brake Disk	900	794712	Replacement MST - 206-545C Transaxle
37	790007	Brake Pad Plate			
38	799021	Brake Pad (pkg of 2)			
39	786026	Dowel Pin			
40	792076A	Flat Washer .312 ID x .059W			

NOTE: All component dimensions given in U.S. inches
1 inch = 25.4 mm

TRACTOR -- MODEL NUMBER 917.270811

BRIGGS & STRATTON ENGINE-MODEL NUMBER 42E707, TYPE NUMBER 2631-E1

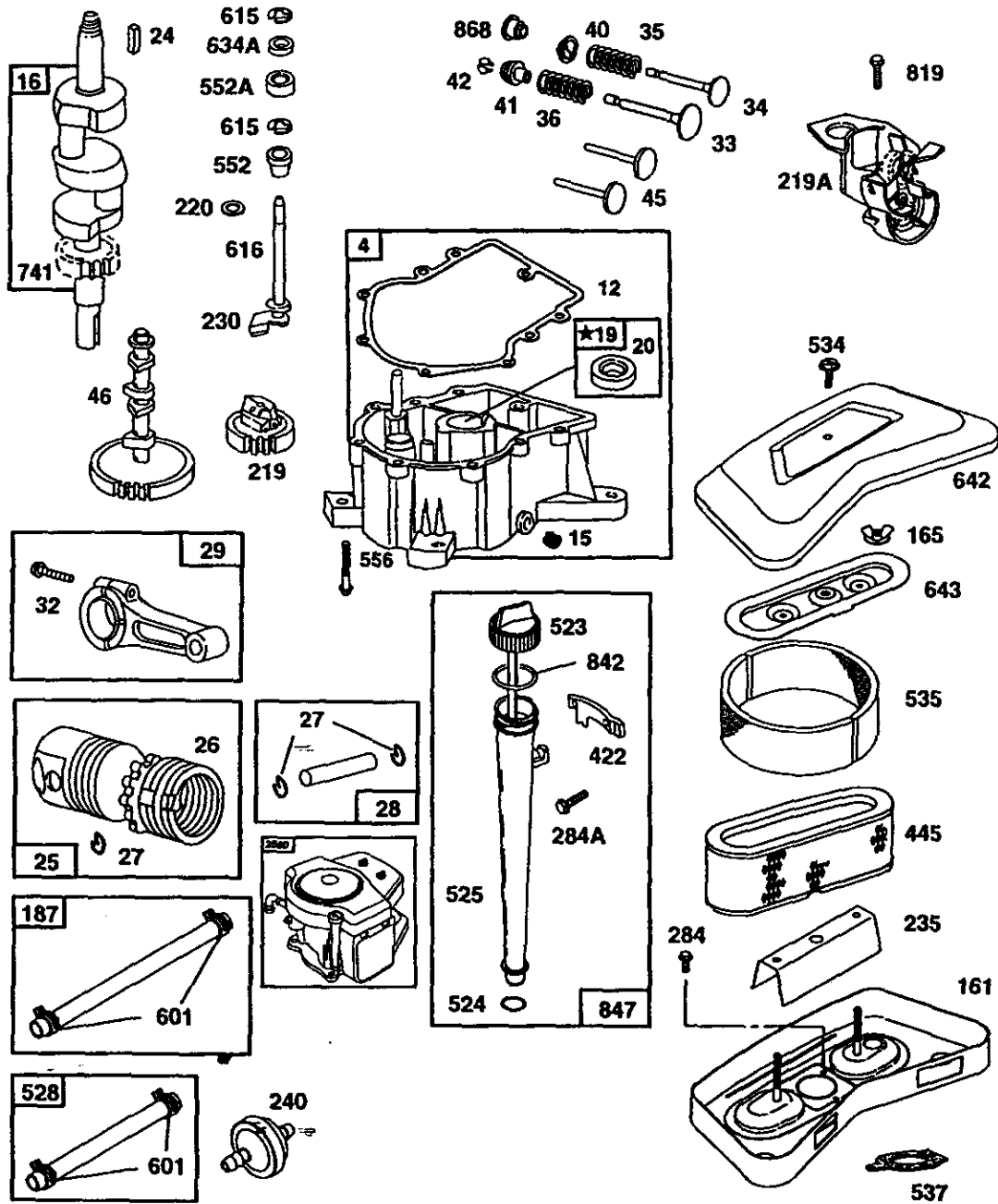

TRACTOR -- MODEL NUMBER 917.270811

BRIGGS & STRATTON ENGINE-MODEL NUMBER 42E707, TYPE NUMBER 2631-E1

358 GASKET SET

861 PUMP REPAIR KIT

121 CARBURETOR KIT

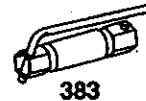
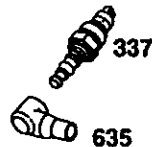
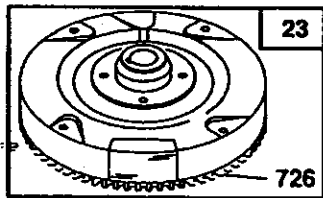
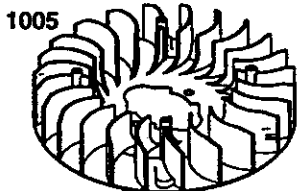
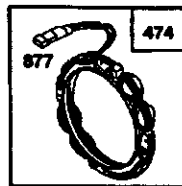
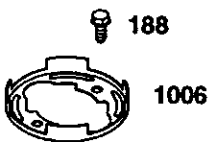
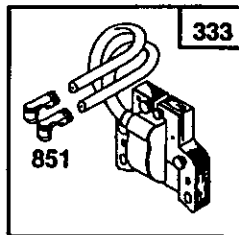
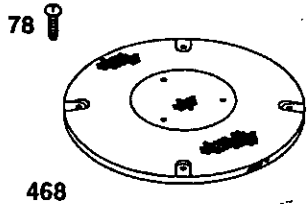
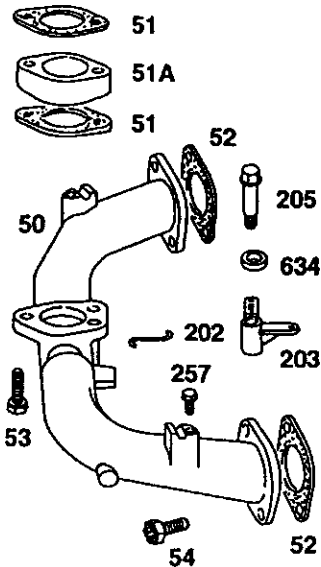
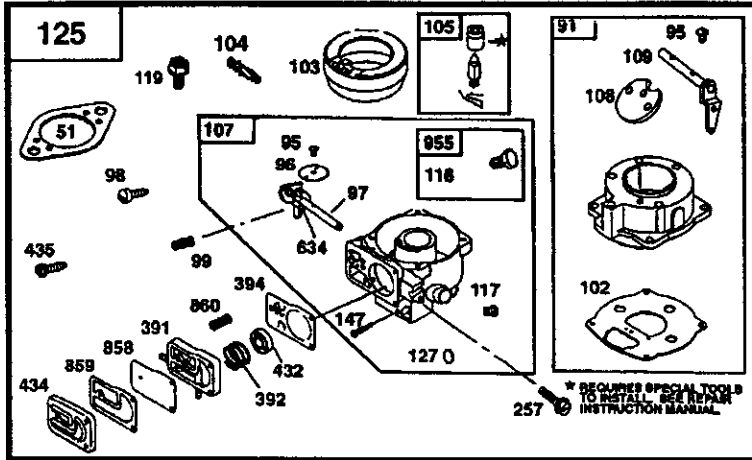

TRACTOR -- MODEL NUMBER 917.270811

BRIGGS & STRATTON ENGINE-MODEL NUMBER 42E707, TYPE NUMBER 2631-E1

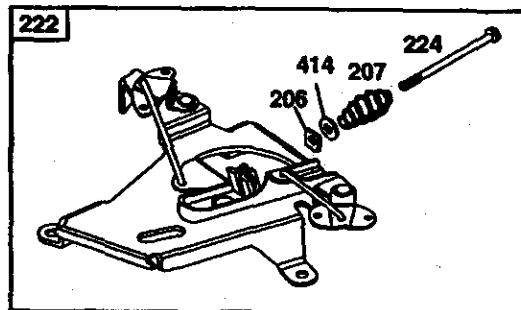
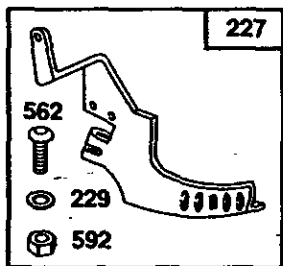
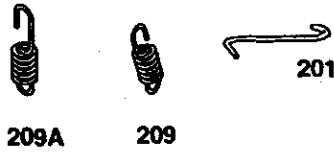
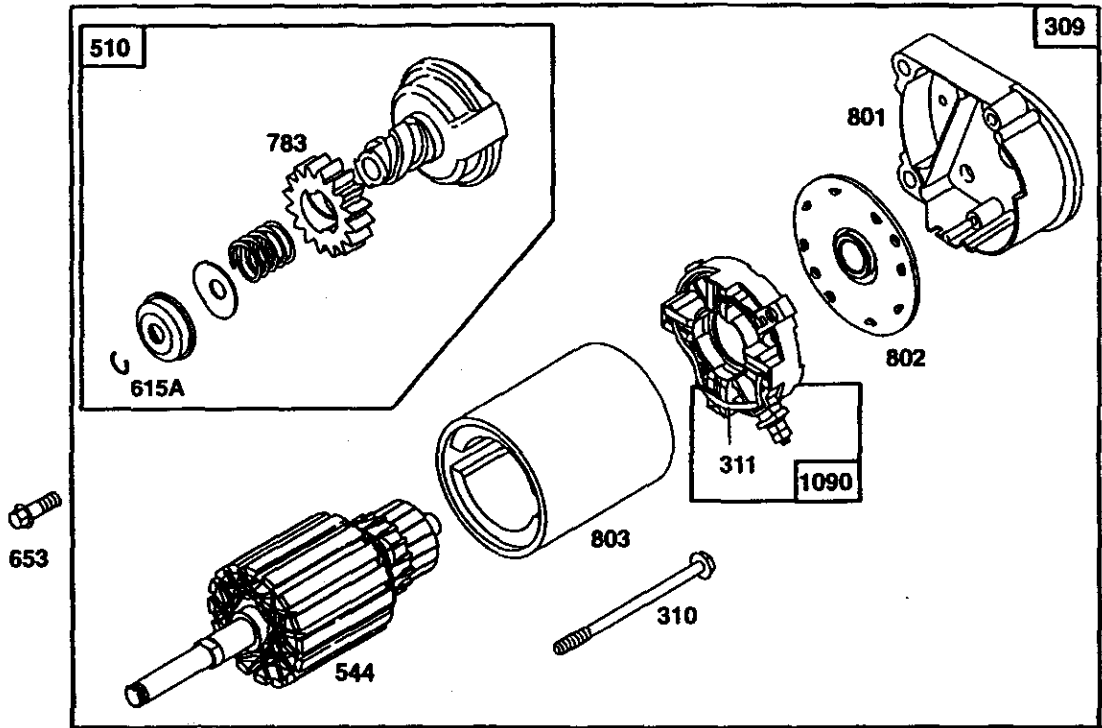

TRACTOR - - MODEL NUMBER 917.270811

BRIGGS & STRATTON ENGINE-MODEL NUMBER 42E707, TYPE NUMBER 2631-E1

KEY NO.	PART NO.	DESCRIPTION	KEY NO.	PART NO.	DESCRIPTION
1	497074	Cylinder Assembly	52	270884	* Gasket, Intake Manifold Mounting
2	399265	Bushing	53	93970	Screw, Hex Head, Carburetor to Manifold
3	391086	* Seal, Oil	54	93208	Screw, Phillips
4	493304	Sump, Engine	75	222511	Washer, Spring
5	493457	Head, Cylinder #1	78	95039	Screw, Hex
5A	493458	Head, Cylinder #2	91	499281	Body Assembly, Upper
7	271867	* Gasket, Cylinder Head #1	95	93499	Screw, Sems
7A	271868	* Gasket, Cylinder Head #2	96	221939	Valve, Throttle
8	495754	Breather Assembly #1	97	499172	Shaft, Throttle
8A	222892	Cover, Breather Cylinder #2 (Used Only on Key #572, Air Baffle with Holes for Mounting)	98	91920	Screw, Fillister Head
9	27803	* Gasket, Breather	99	26157	Spring, Throttle Adjust
10	94382	Screw, Sems	102	271607	** Gasket, Carburetor Body
10A	94830	Screw, Sems	103	298514	Float, Carburetor
11	280225	Tube, Breather	104	231435	** Pin, Float Hinge
12	273208	* Gasket, Crankcase, .015" Thick	105	394682	** Valve, Needle
	271188	* Gasket, Crankcase, .005" Thick	107	499655	Body Assembly, Lower
	271189	* Gasket, Crankcase, .009" Thick	108	225373	Valve, Choke
13	94565	Screw, Cylinder Head	109	392673	Shaft, Choke
15	94239	Plug, Oil Drain	116	280474	* O-Ring
16	394028	Crankshaft	117	232018	Jet, Needle Valve, Fixed
	94196	Timing Gear Key		232022	Jet, Needle Valve, Fixed, High Altitude
19	399264	Bushing	119	94152	Screw, Hex Head
20	291675	* Seal, Oil	121	491539	Carburetor Kit
22	94724	Screw, Sems	125	19306	Carburetor
23	491180	Flywheel	127	223472	** Plug, Welch
24	222698	Key, Flywheel	147	497684	Jet, Pilot
25	498584	Piston Assembly, Standard Size	161	496599	Base, Air Cleaner
	498585	Piston Assembly, .010" Oversize	165	94289	Nut, Wing
	498586	Piston Assembly, .020" Oversize	187	299146	Line, Fuel, 28" Long (Cut to Suit)
	498587	Piston Assembly, .030" Oversize	188	94627	Screw
26	394959	Ring Set, Standard Size	201	262683	Link
	394960	Ring Set, .010" Oversize	202	262684	Link
	394961	Ring Set, .020" Oversize	203	280997	Crank, Bell
	394962	Ring Set, .030" Oversize	205	93971	Screw, Hex Head
27	263129	Lock, Piston Pin	206	94298	Nut
28	498319	Pin, Piston, Standard Size	207	262337	Spring, Control, Rod
	391286	Pin, Piston, .005" Oversize	209	262352	Spring, Governor
29	394306	Rod, Connecting, Standard Size	209A	261563	Spring, Governor Idle
	397158	Rod, Connecting, .020" Undersize	219	394348	Gear, Governor
32	94671	Screw, Connecting Rod	219A	393415	Oil Slinger
33	390420	Valve, Exhaust	220	222773	Washer, Thrust
34	261528	Valve, Intake	222	491282	Bracket, Control
35	65906	Spring, Valve, Intake	224	94297	Screw, Torx
36	26828	Spring, Valve, Exhaust			* Included in Gasket Set (495868)
40	221596	Retainer, Valve, Intake			** Included in Carburetor Kit (491539)
41	292260	Retainer, Valve, Exhaust			*** Included in Carburetor Kit (491539), and Pump Repair Kit (393397)
42	494553	* Keeper, Valve			**** Included in Gasket Set (495868), and Carburetor Kit (491539)
45	261368	Tappet, Valve			
46	214484	Gear, Cam			
50	213290	Manifold, Intake			
51	271412	**** Gasket, Carburetor Mounting			
51A	281412	Spacer, Carburetor			

NOTE: All component dimensions given in U.S. inches
1 inch = 25.4 mm

TRACTOR - - MODEL NUMBER 917.270811

BRIGGS & STRATTON ENGINE-MODEL NUMBER 42E707, TYPE NUMBER 2631-E1

KEY NO.	PART NO.	DESCRIPTION	KEY NO.	PART NO.	DESCRIPTION
227	491297	Lever Assembly, Governor	572	224816	Baffle, Air, Cylinder #2
229	62199	Washer	573	491304	Plate, Back
230	223882	Washer, Governor Crank, Inside	592	92278	Nut, Hex.
235	224995	Shield, Fuel Spray	601	93053	Clamp, Hose
240	394358	Filter, Fuel	615	94296	Retainer, E-Ring
244	230318	Connector, Fuel Line	615A	263080	Retainer
257	93897	Screw, Sems	616	491530	Crank, Governor
284	94674	Screw, Hex Head	634	271013	** Washer, Throttle Shaft
284A	94882	Screw, Hex Head	634A	491287	* Seal, Governor Shaft
304	495469	Housing, Blower, Red	635	66538	Boot, Spark Plug
305	94786	Screw, Sems	642	225008	Cover, Air Cleaner
306	222846	Shield, Cylinder	643	496700	Plate, Air Cleaner
306A	223734	Shield, Cylinder	653	93585	Screw, Hex Head
307	94930	Screw, Self-Tapping	726	391362	Gear, Ring (Includes Mounting Parts)
308	224774	Cover, Air Guide			
308A	224775	Cover, Air Guide	741	262989	Gear, Timing
309	497596	Motor, Starter	783	280104	Gear, Starter
310	94003	Bolt, Thru	801	394860	Cap, Drive
311	497608	Brush Set	802	497607	Cap, End
332	230674	Nut, Hex	803	497604	Housing, Starter
333	394891	Armature, Magneto	819	94675	Screw, Hex Head
334	94731	Screw, Sems	842	270920	* Seal, Cap
337	802592	Plug, Spark	847	495715	Tube Assembly, Oil
356	494705	Wire, Stop	851	493880	Terminal, Cable
358	495868	Gasket Set	858	270989	*** Diaphragm, Carburetor
363	19203	Flywheel Puller	859	271025	*** Gasket, Pump
383	89838	Wrench, Spark Plug	860	261358	*** Spring, Diaphragm
391	280197	Body, Pump	861	393397	Repair Kit, Pump
392	261395	*** Spring, Diaphragm	868	497212	Seal, Valve
394	272638	*** Diaphragm, Carburetor	869	261463	Seat, Valve, Intake
414	220680	Washer	870	213316	Seat, Valve, Exhaust
422	222875	Bracket, Oil Fill	871	261961	Bushing, Guide (Exhaust Only)
432	221377	*** Cap, Spring		231218	Bushing, Guide (Intake, Brass)
434	223688	Cover, Diaphragm	877	393456	Wire, Alternator
435	93829	Screw, Diaphragm Cover	881	495901	Plate, Cover
445	394019	Filter, Air	955	397882	Plug and Seal, Solenoid
468	497908	Screen, Rotating	1005	281053	Fan, Flywheel
474	393474	Alternator	1006	224901	Retainer, Fan
482	93621	Screw,	1019	496726	Label Kit
510	497606	Drive, Starter	1090	97605	Retainer, Brush
523	494947	Cap, Oil Fill	2500	42E707-2631	Replacement Engine
524	271157	* Seal, Fill Tube	- -	498543	Replacement Shortblock
525	495348	Tube, Oil Fill (Includes Seals			
528	393815	Hose, Vacuum	*		Included in Gasket Set (495868)
534	94823	Screw, Air Cleaner			
535	272490	Filter, Air	**		Included in Carburetor Kit (491539)
537	271411	**** Gasket, Air Cleaner			
544	497603	Armature, Starter	***		Included in Carburetor Kit (491539), and Pump Repair Kit (393397)
552	262332	Lower Bushing, Governor			
552A	262331	Upper Bushing, Governor			
556	93585	Screw, Hex Head	****		Included in Gasket Set (495868), and Carburetor Kit (491539)
562	93853	Bolt, Governor Lever			
567	94811	Screw, Hex Head, Back Plate to Cylinder			
569	272645	* Gasket, Base			

NOTE: All component dimensions given in U.S. inches
1 inch = 25.4 mm

SUGGESTED GUIDE FOR SIGHTING SLOPES FOR SAFE OPERATION

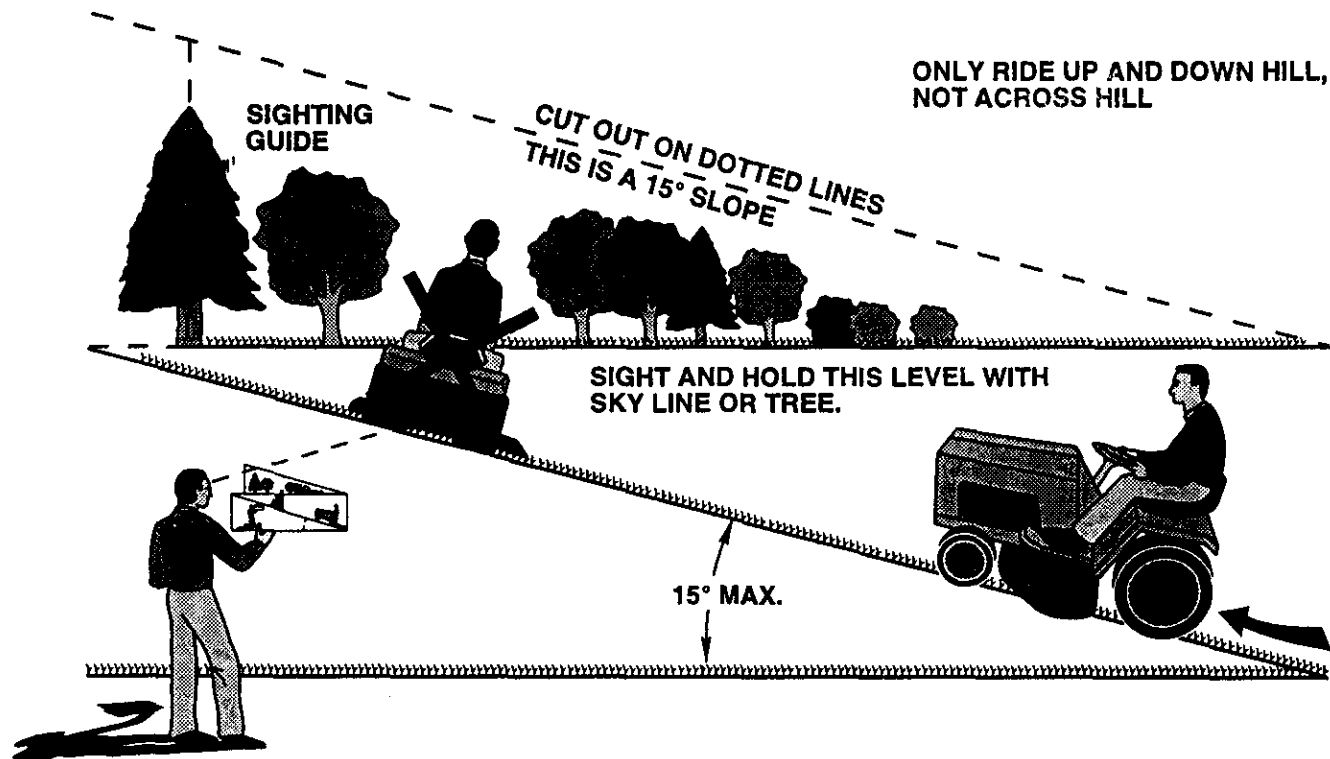

 Operate your Tractor up and down the face of slopes (not greater than 15°), never across the face. Make turns gradually to prevent tipping or loss of control. Exercise extreme caution when changing direction on slopes.

For the repair or replacement parts you need
delivered directly to your home
Call 7 am - 7 pm, 7 days a week

1-800-366-PART

(1-800-366-7278)

Para ordenar piezas con entrega a
domicilio - 1-800-659-7084

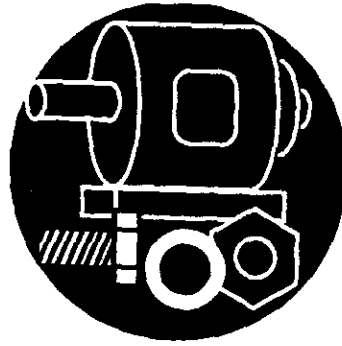

For in-house major brand repair service
Call 24 hours a day, 7 days a week

1-800-4-REPAIR

(1-800-473-7274)

Para pedir servicio de reparación a
domicilio - 1-800-676-5811



For the location of a Sears Parts and
Repair Center in your area

Call 24 hours a day, 7 days a week

1-800-488-1222



For information on purchasing a Sears
Maintenance Agreement or to inquire
about an existing Agreement

Call 9 am - 5 pm, Monday-Saturday

1-800-827-6655



When requesting service or ordering
parts, always provide the following
information:

- Product Type
- Part Number
- Model Number
- Part Description

SEARS
REPAIR SERVICES

America's Repair Specialists