

SEARS

**OWNERS
MANUAL**

**MODEL NO.
625.347030**

SAVE THIS MANUAL

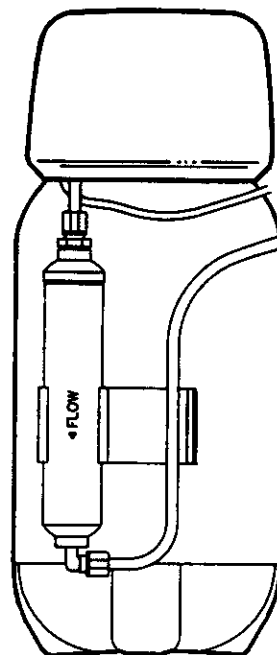

**UNIVERSAL
Undersink Reverse Osmosis
HOME DRINKING
WATER SYSTEMS**

HOW TO INSTALL

HOW IT WORKS

CARE OF

REPAIR PARTS

Sears, Roebuck and Co., Chicago, IL 60684 U.S.A.

TABLE OF CONTENTS

Safety Guides.....	2-3
What Your Home Drinking Water System Will Do.....	3
Things To Check Before You Start To Install.....	4-5
How To Install Your Home Drinking Water System.....	5-9
How Your Home Drinking Water System Works.....	9-10
Care Of Your Home Drinking Water System.....	10-14
Remote Location For The RO.....	14
Dimensions And Specifications.....	15
Repair Parts.....	16-17

WARRANTY

FULL WARRANTY ON SEARS HOME DRINKING WATER SYSTEM (except filter, filter cartridge or membrane)

For one year from the date of purchase, when this home drinking water system is installed and maintained in accordance with our instructions, Sears will repair, free of charge, defects in material and workmanship, except for disposable filters, cartridges and membranes.

TO OBTAIN WARRANTY SERVICE, SIMPLY CONTACT THE NEAREST SEARS SERVICE CENTER THROUGHOUT THE UNITED STATES. This warranty applies only while this product is in use in the United States.

This warranty gives you specific legal rights, and you may have other rights which vary from state to state.

Sears, Roebuck and Co., Dept. 731-CR-W, Sears Tower, Chicago, IL 60684

SEARS INSTALLATION POLICY

All installation labor arranged by Sears shall be performed in a neat, workmanlike manner in accordance with generally accepted trade practices. Further, all installations shall comply with all local laws, codes, regulations and ordinances. Customer shall also be protected, during installation, by insurance relating to Property Damage, Workman's Compensation and Public Liability.

SEARS INSTALLATION WARRANTY

In addition to any warranty extended to you on the Sears merchandise involved, which warranty becomes effective the date the merchandise is installed, should the workmanship of any Sears arranged installation prove faulty within one year, Sears will, upon notice from you, cause such faults to be corrected at no additional cost to you.

SAFETY GUIDES

◆ Read all steps, guides and rules carefully before installing and using your Home Drinking Water System. Follow all steps exactly to correctly install. Reading this book will also help you to get all the benefits from your Home

Drinking Water System.

◆ DO NOT ATTEMPT TO USE THIS PRODUCT TO MAKE SAFE DRINKING WATER FROM

SAFETY GUIDES

NON-POTABLE WATER SOURCES. DO NOT USE THE SYSTEM ON MICROBIOLOGICALLY UNSAFE WATER, OR WATER OF UNKNOWN QUALITY.

- ◆ CHECK WITH YOUR LOCAL PUBLIC WORKS DEPARTMENT FOR PLUMBING AND SANITATION CODES. YOU MUST FOLLOW THEIR GUIDES AS YOU INSTALL THE SYSTEM. FOLLOW YOUR LOCAL CODES IF THEY DIFFER WITH GUIDES IN THIS MANUAL.
- ◆ The Home Drinking Water System works on water pressure of 40 psi (minimum) to 125 psi (maximum). See the table on page 15. If your

house water pressure is over the maximum, install a pressure reducing valve in the water supply to the Home Drinking Water System.

- ◆ Do not install the Home Drinking Water System outside, or in extreme hot or cold temperatures. Temperature of the water supply to the Home Drinking Water System must be between 40°F (minimum) and 100°F (maximum). See the specification table on page 15. DO NOT INSTALL ON HOT WATER.
- ◆ Read the other limits (pH, hardness, etc.) on page 15 and be sure your water supply conforms. Please read WATER SUPPLY, page 4.

WHAT YOUR HOME DRINKING WATER SYSTEM WILL DO

Your Home Drinking Water System is a REVERSE OSMOSIS (RO) water treating unit. It uses household water pressure to **reverse** a natural physical process called **osmosis**. Water, under pressure, is forced through a semi-permeable membrane where minerals and impurities are screened out and sent down the drain with the waste water. These minerals and impurities are measured as total dissolved solids (TDS).

The system includes replaceable pre and postfilter sediment-carbon cartridges. The prefilter removes sand, dirt, rust particles and other sediments. It also takes chlorine out of the feed water. The postfilter removes any remaining tastes and/or odors just before water is taken from the system faucet. The storage area holds almost 1 gallon of RO product water for your needs.

The undersink system connects to a house COLD water pipe for a water supply. An automatic shutoff valve prevents water waste when the storage area is full and the faucet is closed.

The drinking water system gives you a continuous supply of sparkling clear, delicious water for drink-

ing and cooking. Foods will look better and taste better too. The system eliminates the need to buy bottled water. Instead, it puts high quality water right at your fingertips.

NOTE: A product data sheet is included, and also available from Sears. The data sheet lists what this RO system will remove (or reduce) from the water.

ELECTRONIC MONITOR (OPTIONAL*)

The electronic model has 2 water quality sensors, located in the electronic box. Indicator lights on the faucet base work with the sensors, or probes, to show you when water quality is good, and when the system needs servicing.

As you take water from the RO faucet, a flashing green light means the system is giving you high quality RO water. Over a period of time, the RO membrane, prefilter cartridge and postfilter begin to lose efficiency. Flashing amber lights (see pages 10, 11 and 12) tell you when to service the RO membrane and filters.

* An electronic monitor kit is available from Sears, Stock No. 42-34704.

THINGS TO CHECK BEFORE YOU START TO INSTALL

■ **PARTS IN THE SHIPPING CARTON** — Unpack the carton carefully so needed parts are not discarded by mistake. Included are:

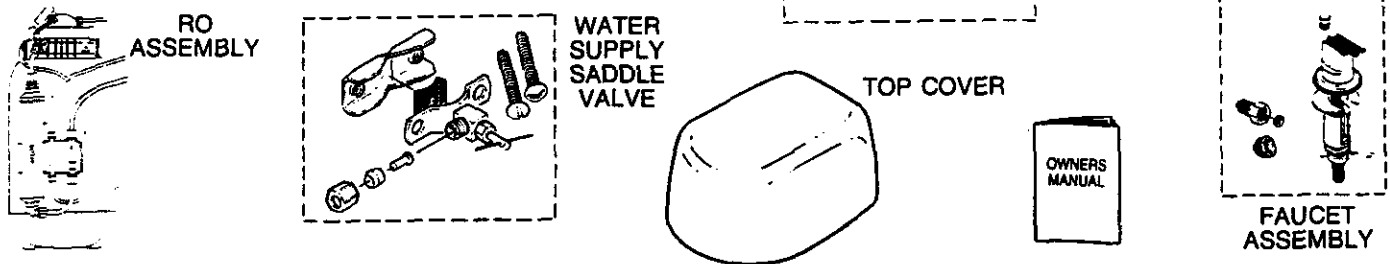

■ **WATER SUPPLY** — The cold water supply to your Home Drinking Water System must be within certain chemical limits (see page 15). If not, it will not make product water as it should, and life of the RO membrane is shortened. Trained salespeople at Sears can arrange for a free water analysis. This analysis will tell you if the water needs other treatment before it goes into the Home Drinking Water System.

filter carbon cartridge removes chlorine from the water before it enters the RO membrane.

IMPORTANT: TO KEEP CHLORINE FROM DESTROYING THE RO MEMBRANE, BE SURE TO REPLACE THIS CHLORINE REMOVAL CARTRIDGE AT LEAST EVERY 6 MONTHS, OR 900 GALLONS. (SEE RO CARE GUIDE, PAGE 14.)

CAUTION: CHLORINE IN WATER SUPPLY. The RO membrane is destroyed by chlorine. A pre-

■ **WHERE TO MOUNT THE RO ASSEMBLY AND LOCATE THE STORAGE TANK** —

The Home Drinking Water System fits nicely under the kitchen or bathroom sink. However, you can install it where most handy for you. You do need a **COLD** water supply pipe and drain point within 6 feet. Where space is limited, you can lay it on a shelf

or floor. Locate the assembly so you can easily get to it to change filters.

The RO System weighs about 40 lbs. when full of water. Set it on the floor or other solid surface that will hold this weight.

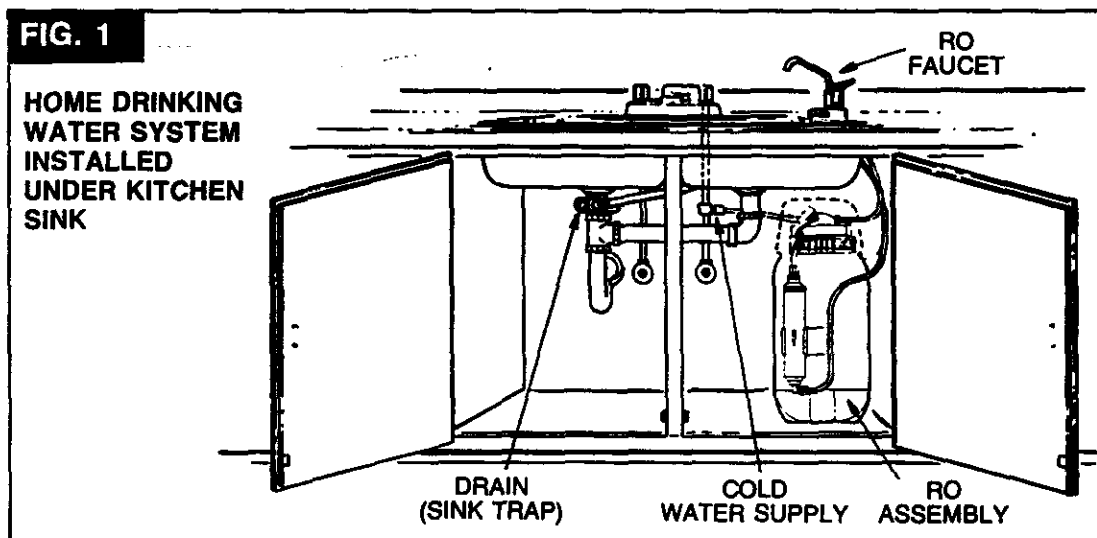

THINGS TO CHECK BEFORE YOU START TO INSTALL

REMOTE LOCATION — You can install the RO assembly or water supply saddle valve in another place away from the RO faucet (please see page 14).

■ **REPLACING ANOTHER RO SYSTEM** — We suggest you remove all parts of another RO system, and use everything included with your new RO system.

TOOLS AND MATERIALS YOU WILL NEED

- 7/16" and 1/2" open end wrenches
- pliers and adjustable wrench
- slotted and Phillips head screwdrivers
- plumbers putty
- pipe joint compound (tread seal) or teflon tape, approved for use on potable water supplies
- hand or battery powered drill with 1/8" and 1/4" bits (if needed for the cold water supply saddle valve, below, and for the drain clamp, page 6)

- electric drill and bits, if hole is needed for the RO faucet, page 7

CAUTION: TO AVOID DAMAGING A SINK BEYOND REPAIR, CONSULT A QUALIFIED PLUMBER OR INSTALLER FOR GUIDES BEFORE DRILLING HOLES IN PORCELAIN OR STAINLESS STEEL.

HOW TO INSTALL YOUR HOME DRINKING WATER SYSTEM

STEP 1 — INSTALL THE COLD WATER SUPPLY SADDLE VALVE (FIG. 2)

■ Install this valve on the COLD water pipe to the kitchen sink (FIG. 2).

■ This valve has a cutting pin and will make its own hole in copper or plastic pipe. To install on iron pipe, you have to drill a 1/8" diameter hole for the cutting pin.

DANGER (IF DRILLING PIPE): TO PROTECT YOURSELF FROM SERIOUS INJURY OR FATAL SHOCK, USE A HAND OR BATTERY POWERED DRILL ONLY TO MAKE THE HOLE. DO NOT USE AN ELECTRIC DRILL.

■ USE THE FOLLOWING GUIDES TO INSTALL:

1. Close the house main water supply valve. Open a high and low faucet in the house to drain water from the pipes.

2. Looking at FIG. 2, if not already done, turn the valve into clamp A and tighten. Turn the valve handle all the way out.

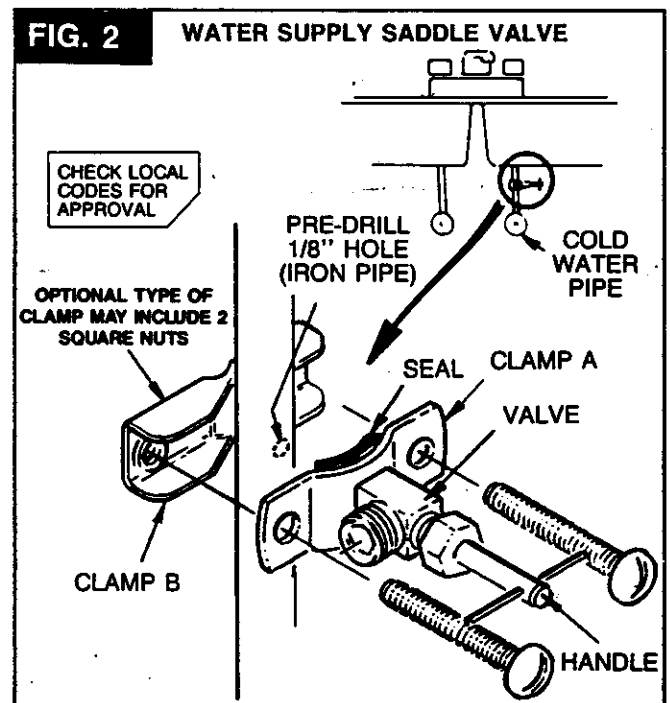

HOW TO INSTALL YOUR HOME DRINKING WATER SYSTEM

continued from page 5

NOTE: If you have to drill a 1/8" diameter hole, hold the valve with clamp A up to the pipe and mark the spot to drill. **BEFORE DRILLING, READ THE DANGER NOTE ON PAGE 5.**

3. Place the seal on the inside of clamp A as shown. Locate clamp A (turn handle in to align pin if pre-drilled hole) and clamp B on the pipe. Fasten in place using 2 screws. Tighten each screw evenly, but do not overtighten and crush the pipe.

4. Turn the valve handle inward to make a hole in the copper or plastic pipe.

DO NOT TURN ON THE WATER SUPPLY AT THIS TIME.

NOTE: BE SURE THE VALVE HANDLE PACKING NUT IS TIGHT.

STEP 2 — INSTALL THE DRAIN CLAMP (FIG. 3)

■ The drain clamp fits up to 1-3/4" diameter drain pipe.

■ The best place to install the clamp is . . .

A. about 3" above the standing water level in the sink p-trap (drawing A).

B. on the horizontal drain pipe run of a double bowl sink (drawing B).

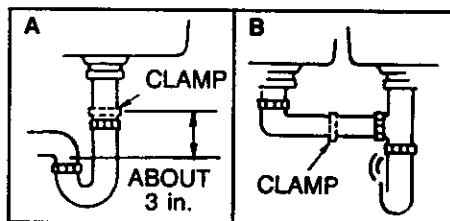

■ Locate so drain tubing from the faucet (FIG. 5) makes a straight run to the clamp, **without any dips, loops, low spots, or kinks.**

■ You have to drill a 1/4" diameter hole for the saddle clamp.

■ Use the following guides:

1. Remove the paper backing from the gasket and place the sticky side of the gasket into the recessed area of the clamp body.

2. Place the U-bolt around the drain pipe and slide the clamp body onto the bolt.

3. Turn the 2 wing nuts onto the U-bolt and tighten snugly, **BUT DO NOT OVERTIGHTEN AND BREAK THE BODY OR CRUSH THE DRAIN PIPE.**

NOTE: Be sure the pipe is clean and smooth where the gasket will seal.

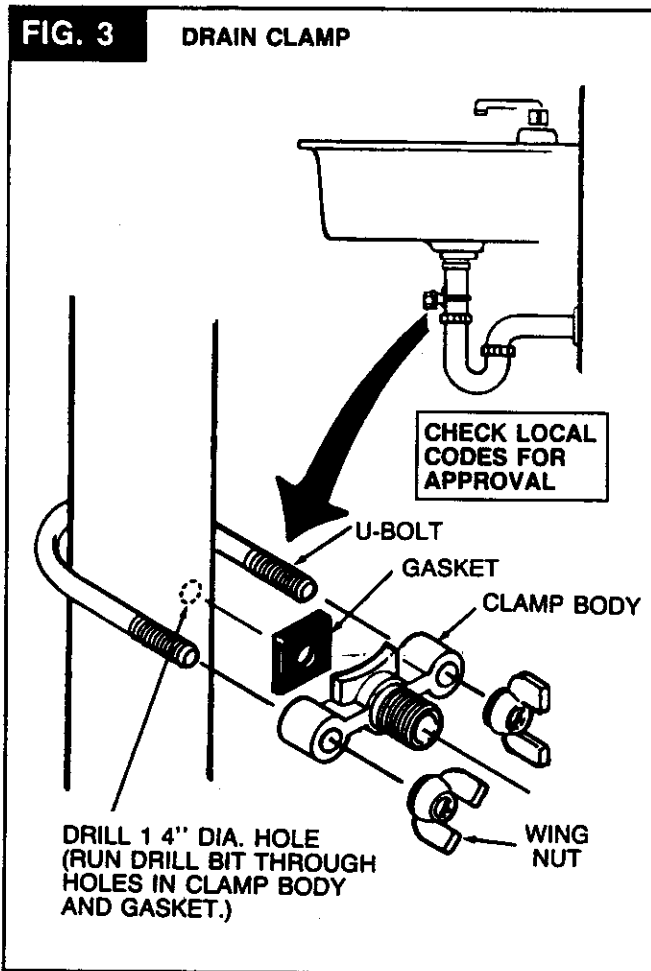

4. Using a hand or battery powered 1/4" drill, make a hole in the drain pipe by going through the threaded fitting on the clamp body (READ THE DANGER NOTE ON PAGE 5).

HOW TO INSTALL YOUR HOME DRINKING WATER SYSTEM

STEP 3 — PREPARE MOUNTING HOLE, ASSEMBLE FAUCET AND INSTALL

A. PREPARE MOUNTING HOLE.

1. Pick 1 of the following places for the faucet where it will fit flat against the surface. Be sure you have room underneath for the tubing connections (FIG. 5, page 8).

... in a hole already in the sink (enlarge to 1-1/4" diameter if needed) to use for an extra faucet or spray.

... drill a hole (1-1/4" diameter) in the sink top.

CAUTION: TO AVOID DAMAGING A SINK

BEYOND REPAIR, CONSULT A QUALIFIED PLUMBER OR INSTALLER FOR GUIDES BEFORE DRILLING HOLES IN PORCELAIN OR STAINLESS STEEL.

... drill a hole (1-1/4" diameter) in the countertop next to the sink.

2. Drill the mounting hole.

3. Place plumbers putty around the edge of the hole to prevent water leakage around the faucet base.

B. ASSEMBLE FAUCET (FIG. 4)

NOTE: IF INSTALLING OPTIONAL ELECTRONIC MONITOR, SEARS STOCK NO. 42-34704, SEE INSTRUCTIONS IN THE MONITOR SYSTEM PACKAGE.

1. Place the compression washer in the tubing adaptor. Turn the adaptor onto the faucet stud and tighten.

2. Loosen the hex nut and back-off down the faucet stud to the adaptor. Slide the plastic bushing down and remove the large steel washer.

3. Wet the o-rings (2) on the faucet spout. Push the spout into the faucet body until it bottoms in the cavity.

C. CONNECT TUBING AND INSTALL FAUCET

1. Move the RO assembly into installation position under the sink, or other desired location.

2. Route the 1/4" tubing marked "1/4" BARB ON FAUCET," and the 3/8" tubing marked "FAUCET," from the bottom, upward through the faucet mounting hole.

3. Using the tubing nut, fasten the 3/8" FAUCET tubing to the tubing adaptor, on the faucet stud. Tighten the nut with a wrench. **NOTE: Cut the tubing as needed for neat appearance, but keep long enough for servicing the RO.**

4. If needed, cut the 1/4" BARB ON FAUCET tubing. Then push the end all the way onto the 1/4" barb fitting on the faucet.

5. Take the 27" long separate piece of 3/8" tubing and pass 1 end down through the sink or countertop hole. Push the other end of the tubing all the way onto the 3/8" barb fitting on the faucet.

6. Lower the faucet into the mounting hole. On the underside of the sink or countertop, locate the large steel washer between the plastic bushing and the mounting hole. Tighten the hex nut until the faucet is held firmly in the desired position.

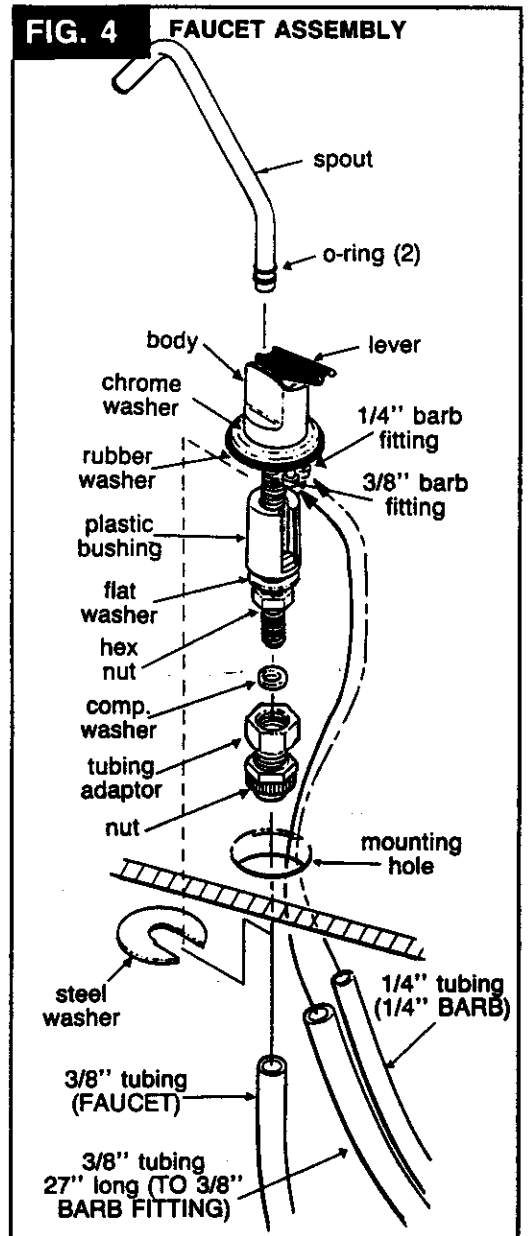

HOW TO INSTALL YOUR HOME DRINKING WATER SYSTEM

STEP 4 — MAKE REMAINING TUBING CONNECTIONS

A. CONNECT TUBING, FAUCET TO DRAIN CLAMP

Looking at FIG. 5, run the 3/8" x 27" tubing from the RO faucet, to the drain clamp at the sink p-trap, FIG. 6. THIS MUST BE A STRAIGHT RUN, WITHOUT DIPS, LOOPS OR LOWSPOTS. Fasten tubing, at the drain clamp, with a 3/8" hex nut.

B. CONNECT TUBING TO WATER SUPPLY (FIG. 5 and 7)

Use the tubing insert, ferrule and nut, at the water supply saddle valve, to fasten the remaining 1/4" tubing (marked "WATER SUPPLY"). Tighten the nut with a wrench.

STEP 5 — SANITIZING, PRESSURE TESTING, PLACING IN "SERVICE"

A. DO THE SANITIZING PROCEDURES, PAGE 13. THEN, CONTINUE WITH STEP B.

B. Double-check all tubing connections to be sure they are tightened.

C. Open the house main water supply valve and the supply saddle valve (turn handle fully out). Open the tank shutoff valve . . . see below.

D. In about 4 hours, pressure will start to build

FIG. 5

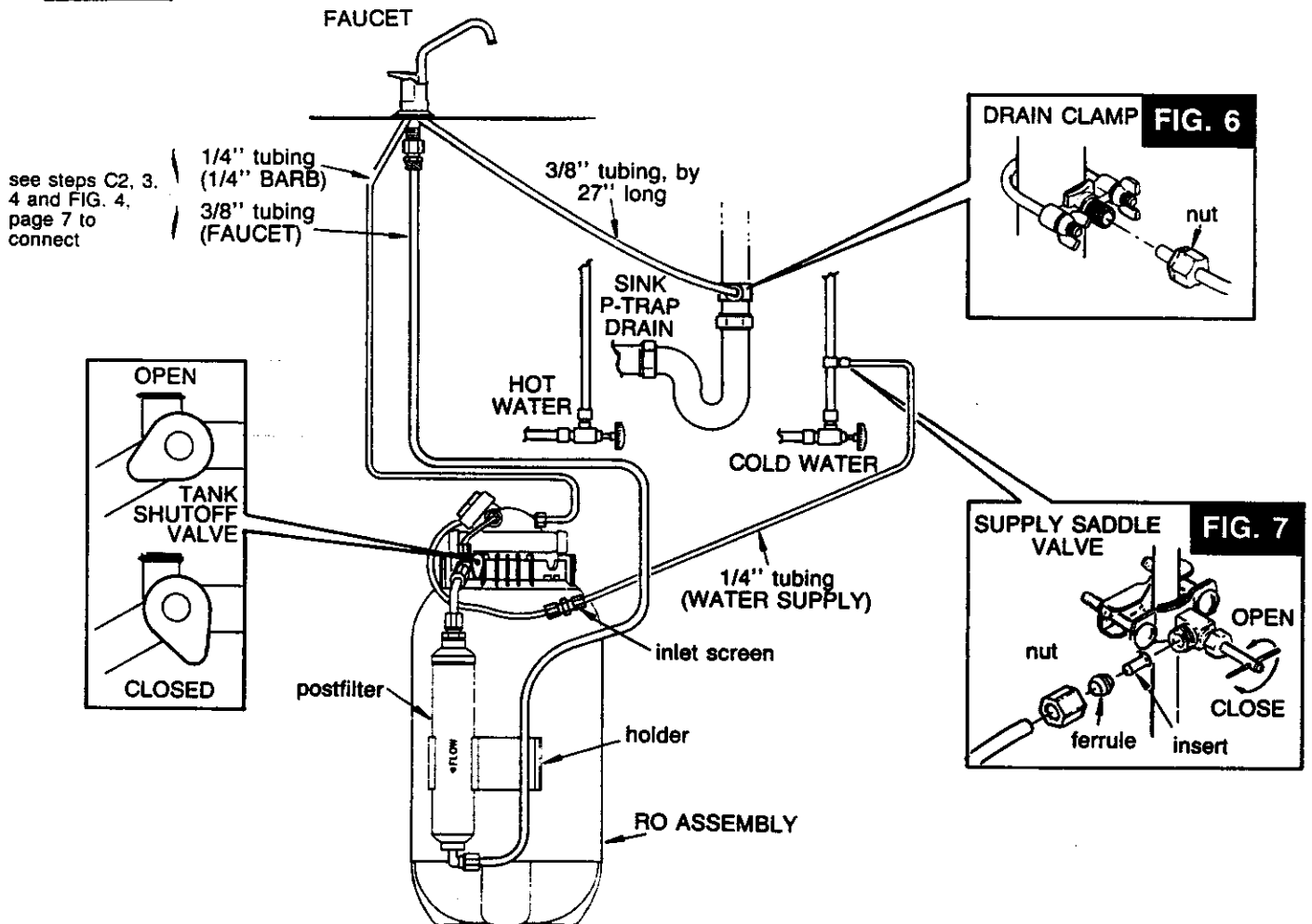

HOW TO INSTALL YOUR HOME DRINKING WATER SYSTEM

in the RO system. At that time, carefully check all fittings and tubing connections for any water leaks. Correct leaks if any are found.

E. IMPORTANT PURGING INSTRUCTIONS:

The RO cartridge contains a food grade preservative that you should clean from it before using the system. The preservative will give product water an unpleasant taste and odor.

1. After the storage bladder has filled (takes about 8 hours), open the system faucet until the bladder is empty.

2. Allow the bladder to fill again for 8 hours, then open the faucet and empty. After 4 purgings, the system is ready to make product water for your use.

HOW YOUR HOME DRINKING WATER SYSTEM WORKS

Water from the cold supply pipe saddle valve is directed through 1/4" tubing, to the RO prefilter. NOTE: If the optional Electronic Monitor, Sears Stock No. 42-34704, is installed, supply water goes to the electronic box first, where the total dissolved solids (TDS) content is measured.

PREFILTER - The prefilter is a replaceable sediment-activated carbon cartridge. It removes sand, silt, dirt, other sediments, and up to 2 parts per million (ppm) chlorine from the supply water. CHLORINE WILL DESTROY THE RO MEMBRANE . . . SEE PAGES 4 AND 11. Filtered, clean, chlorine-free water flows from the prefilter and to the RO membrane.

RO MEMBRANE CARTRIDGE - The RO cartridge, located inside of the prefilter, is a tightly-wound, semi-permeable membrane. Semi-permeable means water will work through the membrane, but first, dissolved solids and organic matter are screened out and flushed to the drain. The screened, high quality product water goes to the storage area, or to the postfilter if the RO faucet is open.

POSTFILTER - After leaving the storage area, but before going to the faucet, product water goes through the postfilter. The postfilter is also a sediment-carbon type filter. It removes any remaining tastes, odors or sediments from the product

FIG. 8

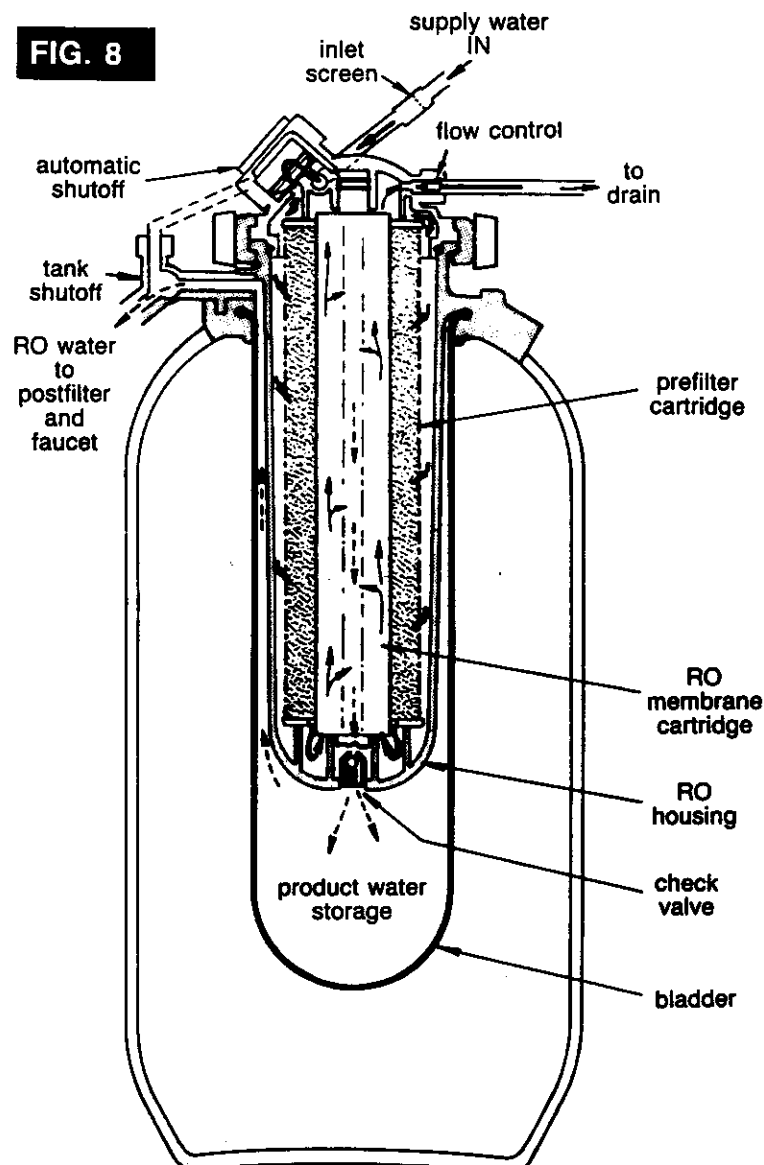

continued on next page

HOW YOUR HOME DRINKING WATER SYSTEM WORKS

POSTFILTER - continued

water. High quality drinking water flows from the postfilter and to the faucet.

NOTE: If the optional Electronic Monitor, Sears Stock No. 42-34704, is installed, before going to the faucet, product water passes through the electronic box and remaining TDS is measured by a sensor.

FAUCET - The sinktop or countertop faucet dispenses the drinking water. It has a hand operated, spring loaded lever to keep the faucet closed and to prevent waste. You can keep the faucet open by pushing upward on the lever and locking it against the spout. To meet plumbing codes, an air-gap is built into the faucet drain water tubes. The air-gap prevents a back siphon of drain water.

OPTIONAL ELECTRONIC MONITOR - When the faucet is opened, lights on the faucet base show how the RO system is working.

- **FLASHING GREEN** - The RO system is giving you high quality product water.
- **FLASHING AMBER "FILT"** - The prefilter cartridge and postfilter need replacing. Also replace the control box batteries. . . see page 12. This light comes on after 6 months, or after 900 gallons of product water use.

- **FLASHING AMBER "RO"** - The RO membrane cartridge needs replacing. (BE SURE TO REPLACE BATTERIES. . . SEE ABOVE, TO ASSURE PROPER "RO" LIGHT OPERATION.) The RO light comes on when the RO membrane no longer removes at least 75% of the TDS from the water supply.

NOTE: Disregard the "RO" light when it flashes for a few seconds at a time.

AUTOMATIC SHUTOFF - When the storage area has filled with product water, and the RO faucet is closed, the automatic shutoff is forced closed. Water flow through the system is stopped before it can enter the RO module, preventing continued flow to the drain. The shutoff remains closed, and water is saved, until the faucet is opened again.

CHECK VALVE - A check valve (FIG. 8) is built into the product water outlet of the RO housing. The check valve prevents a backward flow of product water, from the storage area, to the membrane. A backward flow could rupture the RO membrane.

FLOW CONTROL - The flow control (FIG. 9) keeps flow through the RO cartridge at the needed rate for high quality product water. A cone shaped screen fits over the flow control to help prevent plugging with drain water sediments.

CARE OF YOUR HOME DRINKING WATER SYSTEM

To keep your Home Drinking Water System working and making high quality water, you must make sure supply water is always within the limits shown on page 15. This gives you the longest life from the PREFILTER CARTRIDGE, RO MEMBRANE CARTRIDGE, and POSTFILTER. Each of these will wear out in time and need replacing.

CAUTION: BEFORE WORKING ON THE SYSTEM, DO THE FOLLOWING TO RELIEVE WATER PRESSURE IN THE RO TANK.

- 1a. Turn off the water supply to the RO (turn the supply saddle valve handle all the way inward. . . FIG. 7).
- b. Close the tank shutoff valve (FIG 5 or 8).
- c. Open the product water faucet and keep open.
- d. Disconnect the postfilter.
- e. Using a 2 gallon (minimum) container to catch

the water, open the tank shutoff valve to empty the storage bladder.

2. Looking at FIG. 9, or page 16, remove the protective cap and depress the relief valve stem, allowing air to ENTER the tank (do not block valve passage). Release the valve stem AFTER flow from the shutoff valve slows to a slight drip. Replace the protective cap.

CAUTION: This valve is for vacuum relief only. DO NOT attempt to pressurize the tank.

3. Reconnect the postfilter.

INLET SCREEN - The inlet screen (FIG. 8 or 9) traps sediments in the water supply before they can enter the RO system. Check and clean or replace this small screen (see parts section) often to assure good water flow to the RO system.

CARE OF YOUR HOME DRINKING WATER SYSTEM

PREFILTER CARTRIDGE - You must replace the prefilter cartridge often to protect the RO membrane from being destroyed by chlorine, and/or from plugging with sediments from the water supply. If you have chlorine in the water, replace the cartridge at least every 6 months. If the prefilter cartridge plugs with sediments, water flow into the RO system drops, slowing the making of quality RO water. The RO membrane may also begin to plug with sediments. If this happens, you may not get enough RO water for your needs.

NOTE: If you have the optional Electronic Monitor, the amber "FILT" light on the faucet base will begin to flash after 6 months or 900 gallons of product water use to tell you the filter cartridge needs replacing.

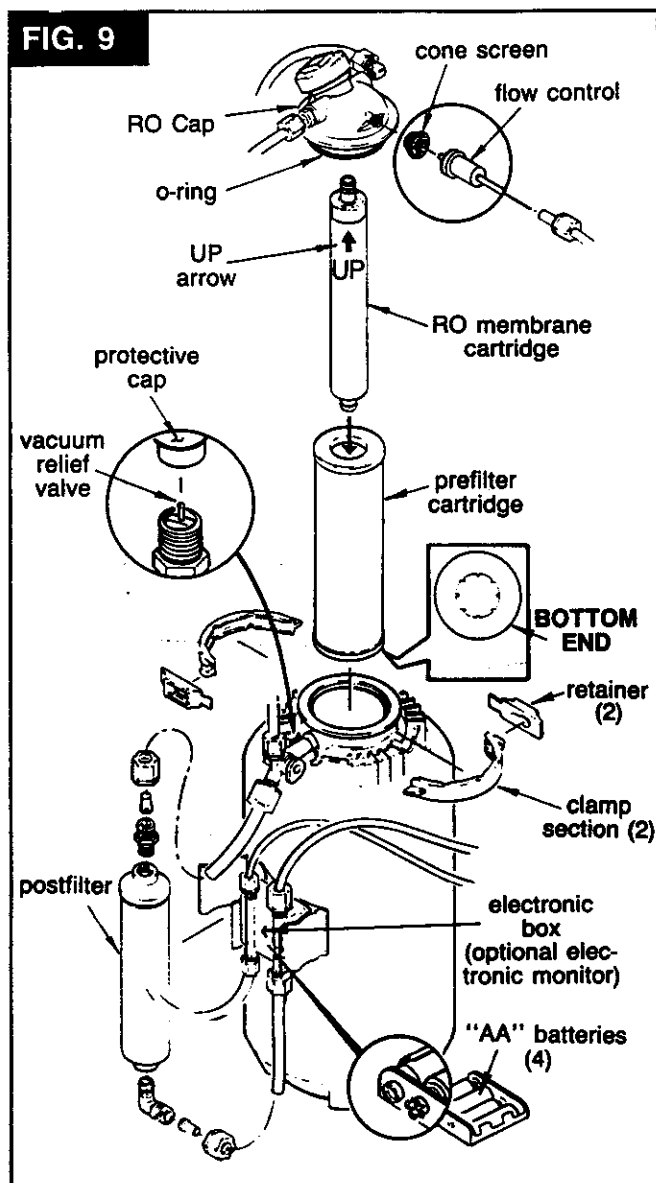

POSTFILTER - Always replace the postfilter at the same time you replace the prefilter cartridge. The postfilter gives the product water a final filtering of any tastes and/or odors that may remain.

TO REPLACE THE POSTFILTER

CAUTION: BE SURE TO RELIEVE PRESSURE, STEPS 1, 2 and 3, BOTTOM OF PAGE 10.

1. Disconnect tubing at both ends (Fig. 9).
2. Pull the filter from the holder and remove fittings from both ends.
3. Observing the flow arrow, on new filter, turn the fittings (use Teflon tape) into both ends. The elbow fitting installs at the bottom end, or outlet.
4. Replace filter into the holder and reconnect the tubing at both ends.

TO REPLACE THE PREFILTER CARTRIDGE

CAUTION: BE SURE TO RELIEVE PRESSURE, STEPS 1, 2 and 3, BOTTOM OF PAGE 10.

IMPORTANT: BE SURE YOUR HANDS ARE CLEAN BEFORE WORKING ON RO SYSTEM INTERNAL PARTS.

1. Remove the clamp retainers and clamp sections (Fig. 9).
 2. Separate the cap from the RO housing (no need to disconnect tubing) and set aside.
- NOTE:** If the cap o-ring seal remained in the RO housing, replace it on the cap.
3. Lift the RO cartridge and prefilter cartridge from the housing, then separate and dispose of the prefilter cartridge.
 4. Dump water remaining in the RO housing.
 5. Slide the RO cartridge INTO THE TOP END of the new prefilter cartridge, as shown in FIG. 9, then place into the RO housing.

NOTE: BE SURE THE BOTTOM END OF THE PREFILTER IS AT THE BOTTOM, AND THE UP (↑) ARROW, ON THE RO CARTRIDGE, POINTS UPWARD.

6. Be sure the cap o-ring has lubrication (silicone grease). Then, push into position and install clamp sections and retainers.
7. If you have the optional Electronic Monitor, replace the electronic box batteries. . . see page 12.

CARE OF YOUR HOME DRINKING WATER SYSTEM

RO MEMBRANE CARTRIDGE - The useful life of the membrane cartridge depends mostly on the pH (see page 15) of your supply water. The lower the pH, the longer the membrane will last. For example, if the feed water has a pH of about 7.0, the cartridge may last for over 1 year; but if the pH is high, cartridge life may be shortened. The high pH weakens the membrane and makes pin hole leaks.

NOTE: If you have the optional Electronic Monitor, the amber "RO" light on the faucet base will begin to flash when RO water quality drops so less than 75% of the TDS are removed from the supply water.

This reverse osmosis system contains a replaceable treatment component critical for effective removal of total dissolved solids. The water should be tested periodically to verify that the system is performing satisfactorily.

TO REPLACE THE RO CARTRIDGE

1. Refer to page 11 and follow instructions under "To Replace the Prefilter Cartridge".
2. Remove and replace the flow control and screen (see steps on this page).
3. Turn on the water supply and **PURGE THE RO CARTRIDGE. . . SEE PAGE 9.**

OPTIONAL ELECTRONIC MONITOR, BATTERIES IN ELECTRONIC BOX - Always replace the batteries (4, "AA" alkaline) in the electronic control box after installing a new prefilter cartridge and postfilter. Good batteries assure proper operation of the indicator lights. Removing the batteries also resets the 6 month or 900 gallon period for monitoring the filter cartridges. See FIG. 9 on page 11.

FLOW CONTROL - A clean flow control is a must for the RO membrane to make high quality product water. The flow control keeps water flow through the membrane at the right rate to get the best quality product water. If the control becomes plugged, so water can't get through, it will only take a short time

for the RO membrane to become useless. A small, cone-shaped screen is positioned over the flow control (FIG. 9) to help keep the flow control clean.

Every time you work on the RO system, check the flow control and screen to make sure they are clean.

TO REPLACE FLOW CONTROL AND SCREEN

CAUTIONS: To install the screen, place the cone end into the RO cap. Then carefully push it in using 1/4" tubing as a tool. Do not force in farther after you feel resistance. Visually check to be sure it is properly positioned.

When installing the flow control, tighten the nut by hand, then another 1/4 to 1/2 turn with a pliers. **DO NOT OVERTIGHTEN AND DISTORT OR CRUSH THE TUBING AND FLOW CONTROL.**

SERVICING THE BLADDER

If the bladder should require inspection and replacement, use the following guides. Refer to the parts illustration on page 16.

CAUTION: BE SURE TO RELIEVE PRESSURE, STEPS 1, 2 and 3, BOTTOM OF PAGE 10.

1. Remove the vacuum relief valve (use 7/16" socket).
2. Rotate the tank shutoff valve 90° and pull from the RO housing.
3. Apply downward pressure on the RO cap while rotating counterclockwise 90°.

NOTE: If the cap turns in the RO housing, first do steps 1 and 2 under "To Replace the Prefilter Cartridge", page 11.

4. Lift the RO housing out of the liner assembly and **PLACE WHERE CLEAN AND SANITARY.**
5. Remove the bladder.

NOTE: BE SURE THE INNER SURFACE OF THE REPLACEMENT BLADDER, AND THE OUTER SURFACE OF THE RO HOUSING ARE CLEAN. USE DISH SOAP AND HOT WATER TO CLEAN AND RINSE.

6. Install the bladder into the liner assembly. Wet the top bead of the bladder with water, or apply a light coating of silicone grease.

CARE OF YOUR HOME DRINKING WATER SYSTEM

7. Install the RO housing, push downward and rotate 90° clockwise to lock in place.
8. Replace the tank shutoff valve and rotate 90° to lock.
9. Using pipe joint compound, replace the vacuum relief valve.
10. **DO THE SANITIZING AND PURGING PROCEDURES, PAGE 8.**

AUTOMATIC SHUTOFF SERVICE

If the shutoff assembly, on the RO cap, requires service, reassemble parts exactly as shown in FIG. 10. Be sure to align indicated marks to properly torque cap to RO cap.

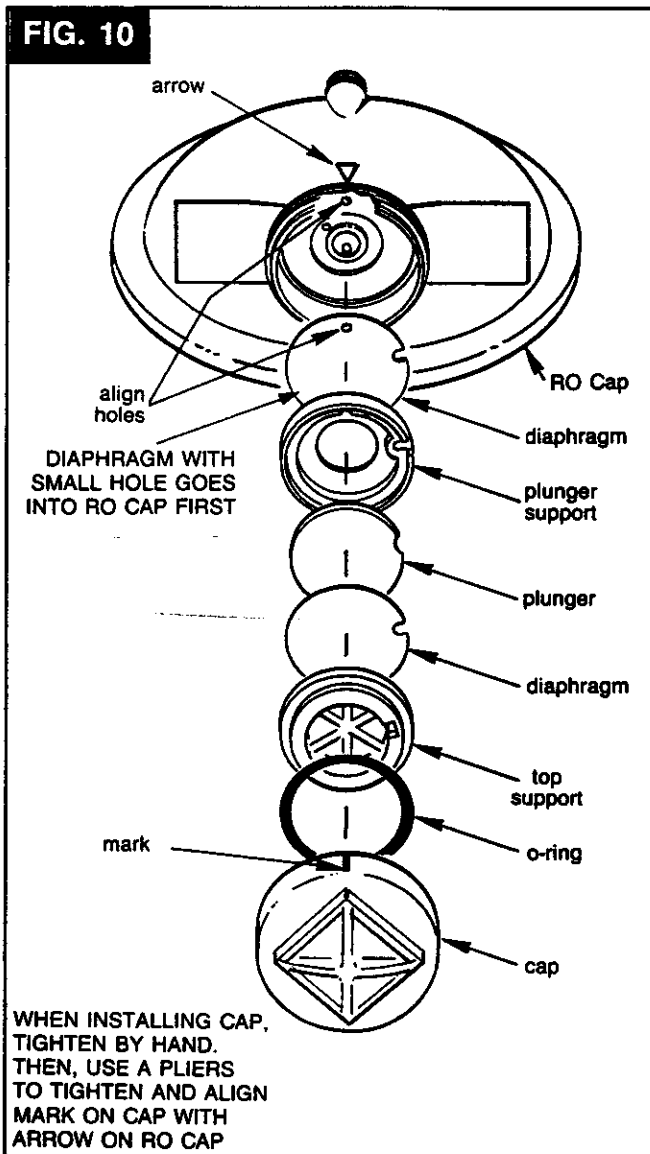

SANITIZING THE RO SYSTEM

Sanitizing is recommended upon installation of the RO system, and after servicing inner parts of the RO housing, and cap. IT IS IMPORTANT FOR THE SERVICE PERSON TO HAVE CLEAN HANDS WHILE HANDLING INNER PARTS OF THE SYSTEM.

1. BE SURE WATER SUPPLY TO THE RO IS TURNED OFF, AND THE RO FAUCET IS OPEN.

2. Remove the clamp retainers and clamp sections, Fig. 9, page 11.

3. Lift the cap from the RO housing (no need to disconnect tubing) and move aside.

NOTE: IF THE CAP O-RING SEAL REMAINED IN THE RO HOUSING, REPLACE IT ON THE CAP.

4. Remove the RO cartridge and prefilter cartridge from the RO housing. If needed, flush housing with fresh, clean water.

5. Fill the RO housing, with fresh water, to about 1 inch from the top. Add 1.0 oz. of chlorine (ordinary 5.25% household bleach ... Hilex, Clorox, etc.) and mix in the water. DO NOT ADD CHLORINE FIRST. Concentrated, it will attack plastics.

6. Replace the cap, with o-ring, and install the retaining clamps.

7. Connect the RO faucet product water tubing directly to the tank shutoff valve, isolating the carbon postfilter.

8. Open the tank shutoff valve, and the water supply to the RO. Open the RO faucet, locking the lever upward, against the spout.

9. Allow water to circulate through the system until the bleach odor is gone.

10. Turn off the water supply to the RO. Close the RO faucet after water flow stops.

11. Reconnect the postfilter (replace used filter) to the RO system, Fig. 9, page 11.

12a. Do steps 2 and 3.

b. Replace the RO cartridge and prefilter cartridge (BE SURE YOUR HANDS ARE CLEAN).

c. Do step 6.

d. Turn to page 8 and do the pressure testing and purging steps B through E.

CARE OF YOUR HOME DRINKING WATER SYSTEM

RO CARE GUIDE

MODEL NO. 625.347030

1. AT LEAST every 6 months, or 900 gallons of product water use, replace the prefilter cartridge and postfilter. Clean or replace the flow control and screen. Also clean or replace the water supply inlet screen.

2. Replace the RO membrane when the percent rejection of TDS is less than shown in the specifications (see item B, below). Clean or replace the flow control and screen. Also clean or replace the water supply inlet screen.

If any of the following happen before the 6 months or 900 gallons, replace as shown.

A. SLOW MAKING OF PRODUCT WATER - Replace the prefilter cartridge. (BE SURE WATER SUPPLY INLET SCREEN IS CLEAN). If rate does not improve, then replace the postfilter and RO membrane.

B. HIGH TOTAL DISSOLVED SOLIDS (TDS) IN PRODUCT WATER. You can get a free TDS test through Sears retail stores, catalog or service departments. If the store or service department does not have a TDS meter, you can send treated and untreated water samples to the Water Analysis Lab for a free test. It is important to test both the treated and untreated water to determine system performance. If the total dissolved solids (TDS) is not within the system's performance guidelines, replace the prefilter cartridge, postfilter, and RO membrane.

C. CHLORINE TASTE AND/OR ODOR - Replace prefilter cartridge, postfilter, and RO membrane.

WITH OPTIONAL MONITOR, SEARS STOCK NO. 42-34704

1. Replace the prefilter cartridge and postfilter when the amber "FILT" light begins to flash while taking product water from the RO faucet. Clean or replace the flow control and screen, and replace the batteries in the electronic control box. Also clean or replace the water supply inlet screen.

2. Replace the RO membrane cartridge when the amber "RO" light begins to flash while taking product water from the RO faucet. Clean or replace the flow control and screens. Also clean or replace the water supply inlet screen.

NOTE: If slow making of product water occurs before an amber light begins to flash, see A in left hand column.

REMOTE INSTALLATION LOCATION

INSTALLING RO ASSEMBLY, AND/OR SUPPLY SADDLE VALVE IN REMOTE LOCATION

Longer lengths of tubing are available from Sears (see page 17) for installing the RO assembly, and/or water supply saddle valve away from the RO faucet. Examples: In the basement, under the kitchen or bathroom sink. In a closet or room nearby the kitchen or bathroom.

You can run the RO assembly drain tubing directly to an open drain and bypass the faucet. Suitable open drains include a laundry tub, floor, sump and

stand pipe drains. It is very important to keep the end of the RO drain tubing at least 1-1/2" above the drain point. This provides an air gap to prevent a back-siphon of sewer water.

Omit the following steps:
 —all of STEP 2, page 6
 —STEPS C4 and C5, page 7
 —STEP 4A, page 8

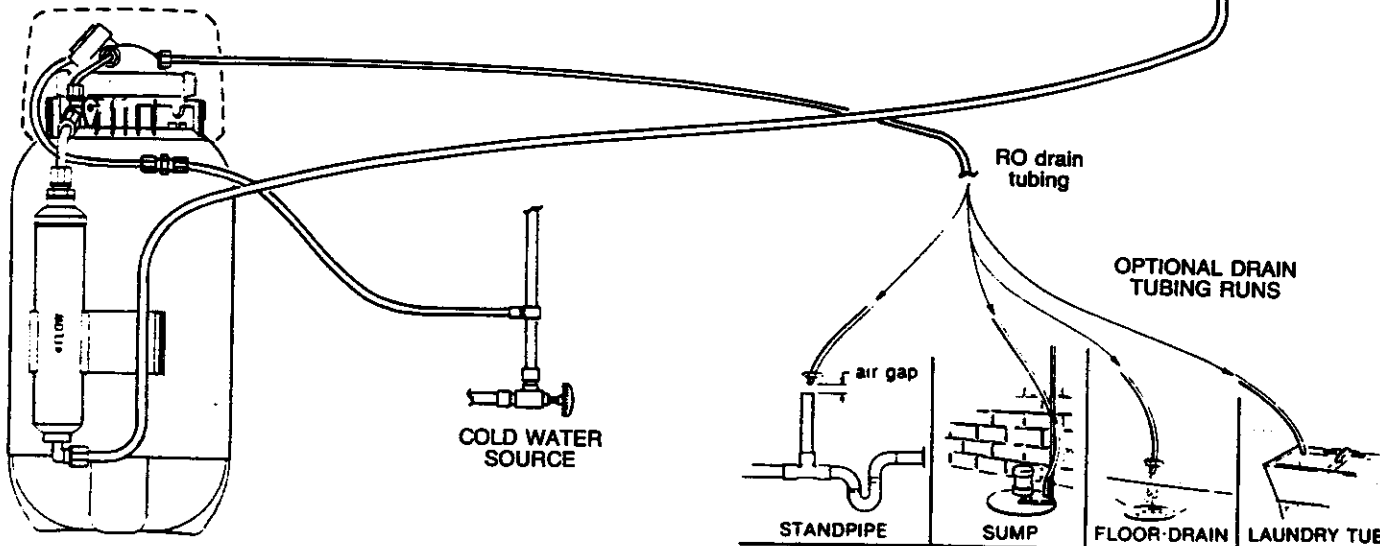
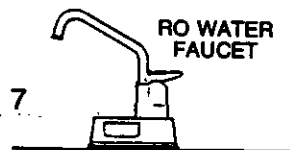

DIMENSIONS — SPECIFICATIONS

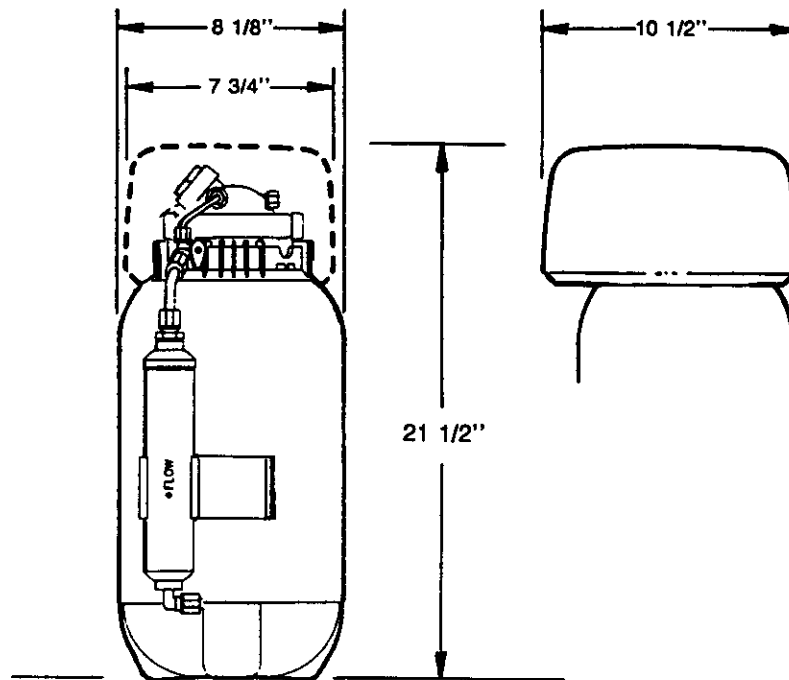

Supply water pressure limits Supply water temperature limits Maximum total dissolved solids (TDS) Maximum water hardness @6.9 pH Maximum iron, manganese, hyd. sulfide Chlorine in supply water (SEE PAGE 4) Supply water pH limits Product (quality) water, 24 hrs.* Waste water per gal. product water, 24 hrs.* Percent rejection of TDS, minimum (new membrane)* Storage capacity Product water vending flow	40-125 PSI 40-100°F 2500 PPM 10 GPG 0 Max. 2.0 PPM ^⓪ 4-11 pH 20 Gal. 3 Gal. 90% 1 Gal. 1/2 GPM	<u>METRIC</u> 280-860 kPa 5-40°C 76 liters 11.4 liters 3.8 liters 1.9 liters/min.
--	--	---

*Supply water at 60 psi and 77°F with 750 parts per million sodium chloride. Quality water production, amount of waste water and percent rejection all vary with changes in pressure, temperature and total dissolved solids.

⓪ Up to 2.0 ppm removed by the RO prefilter cartridge.

NOTE: This product is tested and complies with Water Quality Association Standards.

REPAIR PARTS

SEARS HOME DRINKING WATER SYSTEM
MODEL NO. 625.347030

Undersink Reverse Osmosis

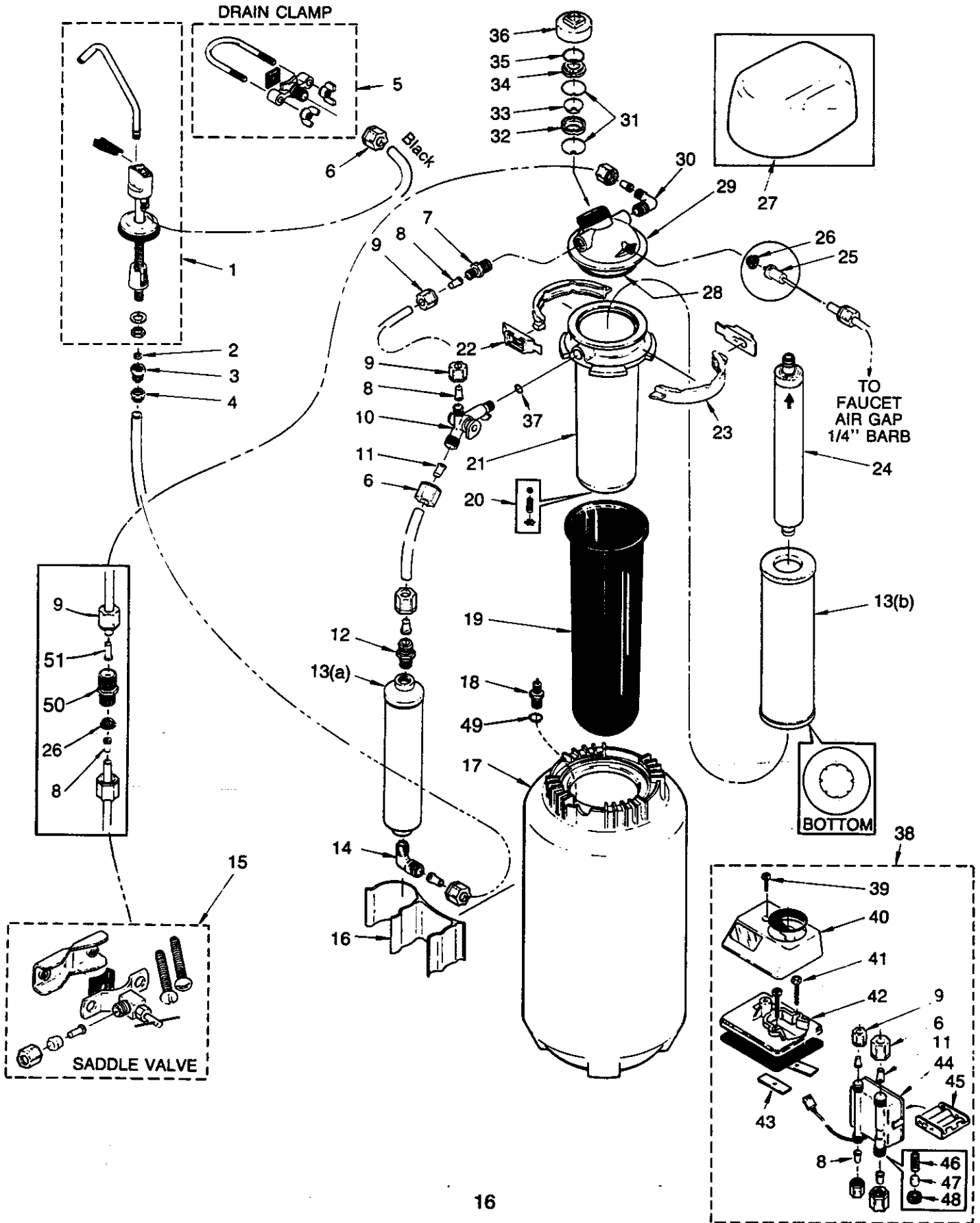

REPAIR PARTS

SEARS HOME DRINKING WATER SYSTEM Undersink Reverse Osmosis MODEL NO. 625.347030

KEY NO.	PART NUMBER	DESCRIPTION OF PART	KEY NO.	PART NUMBER	DESCRIPTION OF PART
1	7095925	Faucet	30	7124986	Elbow, 1/4" NPT x 1/4" Tubing
2	1260600	Washer	31	7125932	Diaphragm Kit ①
3	7064144	Adaptor (Incl. Key No. 2 and 4)	32	7113846	Support, Plunger
4	9043201	Nut, 3/8" Tubing	33	7113838	Plunger
5	7079791	Saddle Clamp (drain)	34	7124677	Top Support
6	9003203	Nut, 3/8" Tubing (4 req.)	35	7116755	O-Ring, 1-3/16" I.D. x 1-3/8" O.D.
7	7078127	Connector, 1/4 NPT x 1/4 Tubing ②	36	7131721	Cap
8	9021501	Tubing Insert, 1/4" (4 req.)	37	7116763	O-Ring, 7/16" I.D. x 5/8" O.D.
9	9003204	Nut, 1/4" Tubing (6 req.)			
10	7114509	Tank Shutoff Valve	38	42-34704	RO Electronics Assembly †
11	9021500	Tubing Insert, 3/8"	39	900156	Screw, #6-32 x 5/8"
12	7087485	Connector, 1/4" NPT x 3/8" Tubing	40	7118422	Faucet Base (Includes Key Nos. 39, and 41 thru 43)
13	42-34709	(a) Post Carbon Filter } replacement package has 3 of each (b) Pre Carbon Filter }	41	900713	Screw, #6-32 x 1-3/8" (2 req.)
14	9004502	Elbow, 1/4" NPT x 3/8" Tubing	42	7115262	Faucet Support
15	7011272	Saddle Valve (water supply)	43	7115725	Nut (2 req.)
16	7128702	Filter Holder	44	7115694	Electronic Box
17	7118414	Liner Assembly	45	7115822	Battery Holder ☒
18	7130026	Vacuum Relief Valve	46	1269800	Spring
19	7109910	Bladder	47	7087477	Magnet
20	7121954	Bail-Check Kit	48	7127756	Flow Washer
21	7114559	RO Housing	◆	7126506	Cable Extender, 15' (OPTIONAL, connects between faucet base and elec. box)
22	7088033	Clamp Retainer (2 req.)			
23	7088041	Clamp Section (2 req.)	49	900044	O-Ring, 5/16" x 7/16"
24	42-34706	RO Membrane Cartridge (Includes Key Nos. 25 and 26)	50	9038500	Connector, Union
25	2271406	Flow Control	51	9038700	Tubing Insert (Brass)
26	7095030	Screen, Cone (2 req.)	◆	1288000	Tubing, 3/8" x 90"
27	7126572	Top Cover	◆	7108817	Tubing, 1/4" x 72"
28	7115610	O-Ring, RO Cap—3-1/8" I.D. x 3-3/8" O.D.	◆	811423	Tubing, 1/4" x 20'
29	7110466	RO Cap	◆	7127594	Owners Manual

② System may use an elbow (Key No. 30) in place of this part.

◆ not illustrated

☒ purchase batteries (4, "AA" ALKALINE) locally

† RO electronics not included with Model No. 625.347030...available option

① Diaphragm with extra, small hole goes into the RO cap first. Small hole locates at 12:00 position and centers over vent hole in cap, page 13.

SEARS

**OWNERS
MANUAL**

SERVICE

**MODEL NO.
625.347030**

**HOW TO ORDER
REPAIR PARTS**

**TELL SEARS YOU
WANT IT INSTALLED
THEN RELAX**

Universal Undersink Reverse Osmosis HOME DRINKING WATER SYSTEMS

Now that you have purchased your Sears Home Drinking Water System, should a need ever exist for repair parts or service, simply contact any Sears Service Center. Be sure to provide all pertinent facts when you call or visit.

The model number of your drinking water system is found on the rating decal. This decal is on the side of the RO Liner Assembly.

WHEN ORDERING REPAIR PARTS, ALWAYS GIVE THE FOLLOWING INFORMATION:

- | | |
|----------------|--------------------|
| — PART NUMBER | — PART DESCRIPTION |
| — MODEL NUMBER | — NAME OF ITEM |

All parts listed may be ordered from any Sears Service Center.

If the parts you need are not stocked locally, your order will be electronically transmitted to a Sears Repair Parts Distribution center for handling.

When Sears arranges the installation, you can be sure the job is done right. We will arrange for professional workmanship...and we'll take care of the entire project. What's more, during installation you get insured protection...against property damage and also against accidents to workmen. All you have to do is talk to your Sears salesperson or call your nearest Sears store today for detailed information.

Sears, Roebuck and Co., Chicago, IL 60684 U.S.A.