

Owner's Manual

CRAFTSMAN[®]

27 Ton Hydraulic Log Splitter

Model No.
247.794510

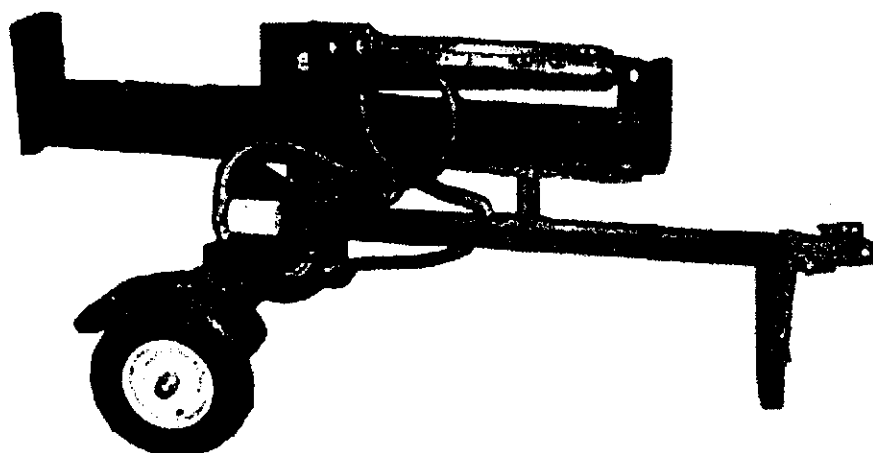

CAUTION: Before using this product, read this manual and follow all Safety Rules and Operating Instructions.

Sears, Roebuck And Co., Hoffman Estates, IL 60179, U.S.A.

SAFETY

ASSEMBLY

OPERATION

MAINTENANCE

ADJUSTMENTS

STORAGE

PARTS LIST

ESPAÑOL

TABLE OF CONTENTS

Content	Page	Content	Page
Warranty Information	2	Maintenance	13
Safe Operation Practices	3	Service & Adjustment	16
Accessories	6	Off-Season Storage	18
Assembly	7	Troubleshooting	19
Operation	9	Parts List	21

WARRANTY INFORMATION

ONE-YEAR WARRANTY ON CRAFTSMAN LOG SPLITTER

For one year from the date of purchase, when this Craftsman log splitter is maintained, lubricated, and tuned up according to the operating and maintenance instructions in the operator's manual, Sears will repair, free of charge, any defect in material or workmanship.

This warranty excludes the tires, spark plug, oil filter and air cleaner, which are expendable parts and become worn during normal use.

If this log splitter is used for commercial or rental purposes, this warranty applies for only 30 days from the date of purchase.

WARRANTY SERVICE IS AVAILABLE BY CONTACTING THE NEAREST SEARS SERVICE CENTER IN THE UNITED STATES. THIS WARRANTY APPLIES ONLY WHILE THIS PRODUCT IS IN USE IN THE UNITED STATES.

This warranty gives you specific legal rights, and you may also have other rights which vary from state to state.

Sears, Roebuck and Co., Dept. 817WA, Hoffman Estates, IL 60179

PRODUCT SPECIFICATIONS

<p>Horsepower: 6.5 Engine Oil..... SAE 30/1.25 pints Fuel Capacity: unleaded/1.5 quarts Hydraulic Fluid Dexron III /4 gallons Tire Pressure..... 30 p.s.i. maximum Spark Plug (Gap .030")..... Champion RJ19LM Magnetron Ignition Air Gap..... .0125"</p>

<p style="text-align: right;">247.794510</p> <p>Model Number Serial Number..... Date of Purchase</p> <p>Record model number, serial number and date of purchase of the log splitter and keep in a safe place for future reference.</p>

SAFE OPERATION PRACTICES



This symbol points out important safety instructions which, if not followed, could endanger the personal safety and/or property of yourself and others. Read and follow all instructions in this manual before attempting to operate your log splitter. Failure to comply with these instructions may result in personal injury. When you see this symbol—heed its warning.



WARNING:

Your log splitter was built to be operated according to the rules for safe operation in this manual. As with any type of power equipment, carelessness or error on the part of the operator can result in serious injury. If you violate any of these rules, you may cause serious injury to yourself or others.



The engine exhaust from this product contains chemicals known to the state of California to cause cancer, birth defects or other reproductive harm.

Towing

- This unit should not be towed on any street, highway or public road without checking the existing federal, local or state requirements. Such information may be obtained by calling your state or local bureau of motor vehicles. Any licensing or modifications needed to comply with federal, local or state vehicle requirements is the sole responsibility of the purchaser.
- Make sure you follow the wiring diagram color codes when installing the light kit on the log splitter. (e.g. ground to ground, left turn to left turn, etc.). Failure to wire unit correctly may cause the tow vehicle wiring to overheat and/or the log splitter lights to operate incorrectly. It may be necessary to replace the turn signal flasher unit in your tow vehicle if it is not capable of operating the additional lights on the log splitter.
- Before towing the log splitter on a street, highway or public road, verify that all lights are functioning properly and the yellow side reflectors are in position. Replace bulbs if they are burnt out.
- Before towing, always check to be certain the log splitter is correctly and securely attached to the tow vehicle, and safety chains are in place. Leave slack in chains for turning allowance.
- Use a class I or higher hitch with a 1-7/8" ball. Keep ball socket and clamp face lubricated with chassis grease.
- Be sure the coupler is secured to the hitch ball and the lock lever is down tight and locked.
- Check vehicle hitch, ball and coupler for signs of wear or damage. Replace any parts that are worn or damaged before towing.
- The coupler must be secured to the log splitter tongue tube with the original equipment bolts and nuts. See your authorized service dealer for replacement parts. Coupler nuts should be tightened securely (20 foot pounds).
- Make sure beam assembly is securely latched in

the horizontal position and jack stand (if provided) is pivoted and secured in the up position before towing log splitter. Never tow with the beam in vertical position.

- Do not tow the log splitter faster than 45 MPH. Higher speeds may damage log splitter. Excessive high speeds may cause the log splitter to "fishtail" or otherwise become unstable.
- Check the tire pressure on the log splitter tires. It must be 30 p.s.i. maximum for highway travel.
- When parking, storing or using your log splitter, keep the coupler off the ground so dirt will not build up in the ball socket.
- Do not allow anyone to sit or ride on your log splitter. They can easily fall off and be seriously injured.

Training

- Before operating this log splitter, read and understand this operator's manual completely. Become familiar with it for your own safety. To fail to do so may cause serious injury. Do not allow anyone to operate your log splitter who has not read this manual. Keep this manual in a safe place for future and regular reference and for ordering replacement parts.
- Never use your splitter for any other purpose than splitting wood. It is designed for this use and any other use may cause an injury. Your log splitter is a precision piece of power equipment, not a toy. Therefore, exercise extreme caution at all times.
- Never allow children to operate your log splitter. Do not allow adults to operate it without proper instruction. Only persons well acquainted with these rules of safe operation should be allowed to use your log splitter.
- Only the operator is to be near your log splitter during use. Keep all others, including pets and children, a minimum of 20 feet away from your work zone. Flying wood can be hazardous. If a

helper is assisting in loading logs, never activate the control until the helper is clear of the area. More accidents occur when more than one person operates the log splitter than at any other time.

- No one should operate this unit while intoxicated or while taking medication that impairs the senses or reactions. A clear mind is essential for safety. Never allow a person who is tired or otherwise not alert to use your log splitter.

Preparation

- Never wear loose clothing or jewelry that can be caught by moving parts of your log splitter and pull you into it. Keep clothing away from all moving parts of your log splitter.
- Wear proper head gear to keep hair away from moving parts. Always wear protective hearing devices as needed.
- Always wear safety shoes. A dropped log can seriously injure your foot.
- Always wear safety glasses or goggles while operating your splitter. A piece of splitting log could fly off and hit your eyes.
- Wear leather work gloves. Be sure they are tight fitting without loose cuffs or draw strings.
- Use your log splitter in daylight, or under good artificial light.
- Never operate your splitter on slippery, wet, muddy or icy surfaces. Safe footing is essential in preventing accidents.
- Never operate your splitter while attached to a towing vehicle.
- Only operate your splitter on level ground and not on the side of a hill. It could tip, or rolling logs or poor footing could cause an accident. Operating the splitter on level ground also prevents the spillage of gasoline from the fuel tank.
- Never attempt to move the log splitter over hilly or uneven terrain without a tow vehicle or adequate help.
- Always block the wheels to prevent movement of log splitter while in operation.
- Check the fuel before starting the engine. Gasoline is an extremely flammable fuel. Do not fill the gasoline tank indoors, when the engine is running, or while the engine is still hot. Replace gasoline cap securely and wipe off any spilled gasoline before starting the engine as it may cause a fire or explosion.
- Both ends of each log must be cut as square as possible to help prevent the log from riding out of the splitter during operation.

Operation

- **Vertical Operating Position:** Stand in front of the log splitter.

Horizontal Operating Position: Stand behind the reservoir tank. See illustrations.

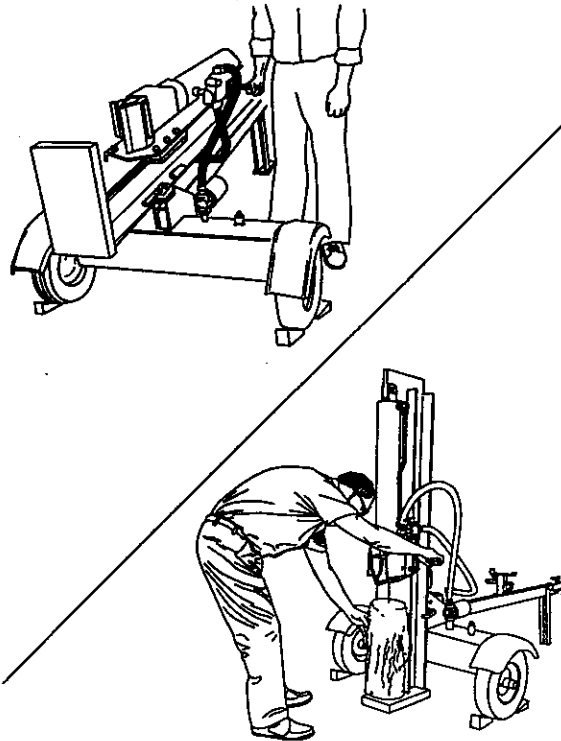

- Know how to stop the unit and disengage the controls.
- Never place hands or feet between log and splitting wedge or between log and end plate during forward or reverse stroke. To do so may result in crushed or amputated fingers or toes, or worse, you may lose an arm or foot.
- Do not straddle the splitter when using it. A slip in any position could result in a serious injury.
- Do not step over your log splitter when the engine is running. You may trip or accidentally activate the splitting wedge if you step over. If you need to get to the other side, walk around.
- Never try to split two logs on top of each other. One may fly out and injure you.
- When loading the log splitter, place your hands on the side of the log, not at the ends. Never attempt to load your splitter while the splitting wedge is in motion. You may get caught by the wedge and injured.
- Only use your hand to operate the splitting wedge or control lever. Never use your foot or a rope or any other extension device. This could result in your inability to stop your splitter quickly enough to avoid injury.
- Always keep fingers away from any cracks that open in the log during splitting operation. They can quickly close and pinch or amputate your fingers.

- Never attempt to split woods across the grain. Some types of wood may burst or fly out of your splitter and result in injury to you or a bystander.
- For logs that are not cut square, the longest portion of the log should be rotated down and the most square end placed against the splitting wedge.
- Keep your work area clean. Immediately remove split wood around your splitter so that you do not stumble over it. Clean chips and dirt off end plate (wood platform) after each log is split, or whenever necessary to maintain flat contact between wood and end plate (platform).
- Never move the log splitter while the engine is running.
- Never leave your log splitter unattended with the engine running. Shut off the engine if you are leaving your splitter, even for a short period of time. Someone could accidentally activate the splitting wedge and be injured.
- Do not run engine in an enclosed area. Exhaust gases contain carbon monoxide. This odorless gas can be deadly when inhaled.
- Be careful not to touch the muffler after the engine has been running. It will be HOT!
- If the equipment should start to vibrate abnormally, stop the engine and check immediately for the cause. Vibration is generally a warning of trouble.
- When cleaning, repairing or inspecting, make certain all moving parts have stopped. Disconnect the spark plug wire and keep the wire away from the plug to prevent accidental starting.

Customer Responsibilities

- Do not operate your splitter in poor mechanical condition or when in need of repair.
- Periodically check that all nuts, bolts, screws, hose clamps and hydraulic fittings are tight to be sure equipment is in safe working condition. Where appropriate, check all safety guards and shields to be sure they are in the proper position. Never operate your splitter with safety guards, shields or other protective features removed. These safety devices are for your protection.
- Replace all damaged or worn parts such as hydraulic hoses and fittings immediately with manufacturer approved replacement parts.
- Do not change the engine governor settings or overspeed the engine. This increases the hazard of personal injury. The maximum engine speed is preset by the manufacturer and is within safety limits.
- Do not alter your log splitter in any manner such as attaching a rope or extension to the control lever or adding to the width or height of the

wedge. Such alterations may cause your splitter to be unsafe.

- Perform all recommended maintenance procedures before you use your splitter.
- Do not service or repair your log splitter without disconnecting the spark plug wire and moving it away from the spark plug.
- Never store the equipment with gasoline in the tank inside of a building where ignition sources are present, such as hot water and space heaters, clothes dryers and the like. Allow the engine to cool before storing in any enclosure.
- Always store gasoline in an approved, tightly sealed container. Store the container in a cool, dry place. Do not store in a building where ignition sources are present.
- To reduce fire hazard, keep engine free of grass, leaves, wood chips, and excessive grease and oil.
- The hydraulic system of your log splitter requires careful inspection, along with the mechanical parts. Be sure to replace frayed, kinked, or otherwise damaged hydraulic components.
- Fluid escaping from a very small hole can be almost invisible. Do not check for leaks with your hand. Escaping fluid under pressure can have sufficient force to penetrate skin, causing serious personal injury. Leaks can be located by passing a piece of cardboard or wood over the suspected leak and looking for discoloration.
- Should it become necessary to loosen or remove any hydraulic fitting or line, be sure to relieve all pressure by shutting off the engine and moving the control handle back and forth several times.
- Do not remove the cap from the hydraulic tank or reservoir while your log splitter is running. Hot oil under pressure could cause injury.
- The pressure relief valve on your splitter is preset at the factory. Do not adjust the valve. Only a qualified service technician should perform this adjustment.
- Completely drain fuel tank prior to storage. This guards against accumulation of fuel fumes which could result in a fire hazard.
- Never store log splitter outside without a waterproof cover. Rain will cause rust on the inside of the cylinder.

Important Information

Always:

- Use clean fluid and check fluid level regularly.
- Use Dexron III Automatic Transmission Fluid or 10W non-foaming hydraulic fluid.
- Use a filter (clean or replace regularly).
- Use a breather cap on fluid reservoir.

- Make certain pump is mounted and aligned properly.
 - Use a flexible "spider" type coupling between engine and pump drive shafts.
 - Keep hoses clear and unblocked.
 - Bleed air out of hoses before operating.
 - Flush and clean hydraulic system before start-up after any malfunction or servicing.
 - Use "pipe dope" on all hydraulic fittings.
 - Allow time for warm-up before splitting wood.
 - Prime the pump before initial start-up by turning over the engine with spark plug disconnected.
 - Split wood with the grain (lengthwise) only.
- Never:**
- Use when fluid is below 20° F, or above 150° F.
 - Use a solid engine/pump coupling.
 - Force pump when mounting.
 - Operate through relief valve.
 - Attempt to adjust unloading or relief valve settings without pressure gauges.
 - Operate with air in hydraulic system.
 - Use Teflon tape on hydraulic fittings.
 - Attempt to cut wood across the grain.

ACCESSORIES

These accessories were available when the log splitter was purchased. These are also available at most Sears retail outlets, catalog and service centers. Most Sears stores can order repair parts for you when you provide the model number of your log splitter.

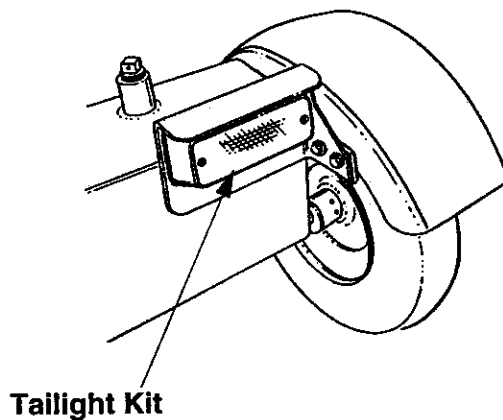
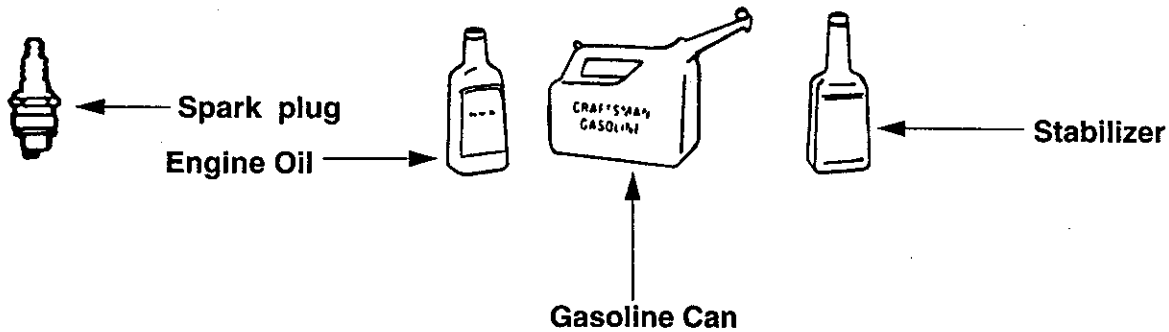

ASSEMBLY

IMPORTANT: This unit is shipped **without gasoline** in the engine. After assembly, see OPERATION section of this manual for proper fuel fill-up.

Tools and Other Items Required

1. Crowbar or Large Screwdriver
2. A pair of 9/16" or Adjustable Wrenches*
3. Screwdriver
4. Cutters
5. Engine Oil (the equipment is shipped with oil in the engine for starting)
6. Unleaded Gasoline
7. Dexron III Automatic Transmission Fluid or 10W Non-Foaming Hydraulic Fluid (Approximately 7 gallons)

Unpacking from Crate



WARNING: Exercise extreme caution as parts are very heavy. Mechanical handling equipment or sufficient manpower should be used to prevent injury.

- Pry the top, sides and ends off crate using a crowbar or large screwdriver.
- Set panels aside to avoid tire punctures or personal injury.
- Remove and discard plastic bag that covers unit. **Note:** Do not remove the banding from around the tank until the log splitter is assembled.

Disconnecting Spark Plug

- Before you proceed with the assembly procedure, disconnect the spark plug wire from the spark plug on the log splitter engine and move the wire away from the spark plug. This will prevent accidental starting. See Figure 1.

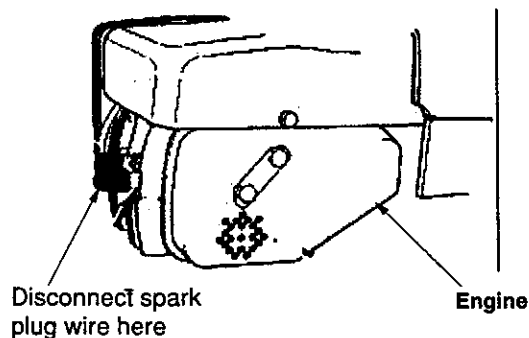

Figure 1

Setting Up Log Splitter

NOTE: All hardware needed for assembling your Craftsman log splitter has been placed in position on the equipment.

- Remove the two bolts, lock washers and hex nuts that secure the tongue assembly to the beam assembly. See Figure 2.
- Unlock the two beam locks by pulling out on the beam locks and pivoting them down. Remove the tongue assembly.

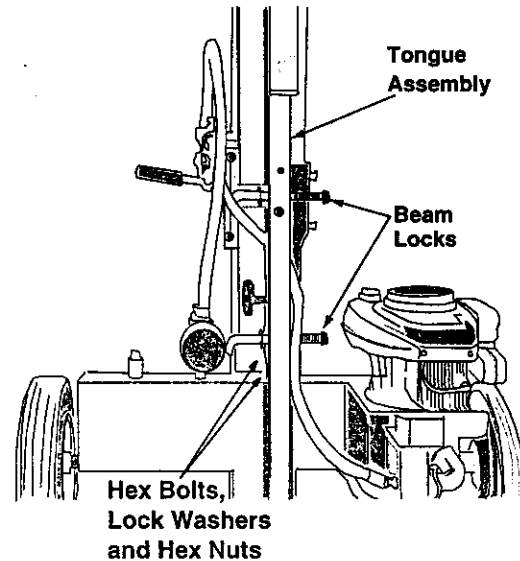

Figure 2

- Place the end of the tongue assembly in between the brackets on the wheel and reservoir tank assembly. Secure with hardware removed earlier. See Figure 3.

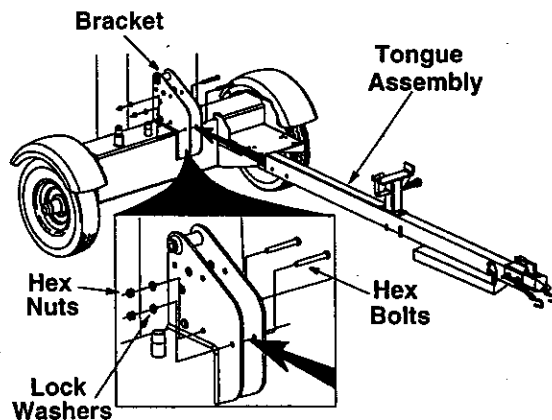

Figure 3

- Remove the spring clip and the clevis pin from the jack stand. Pivot the jack stand to the operating position (90°), and secure with the spring clip and clevis pin. See Figure 4.

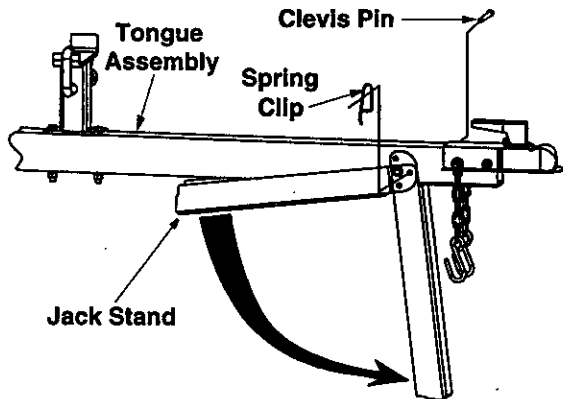

Figure 4

- Cut the two straps from around the reservoir tank assembly.
- Remove the lag screw and washer which secures the beam assembly to the bottom of the crate.
- Lower the beam assembly to its horizontal position. Make certain the beam is locked securely with the horizontal beam lock. See Figure 5.
- Pull the log splitter off the pallet.

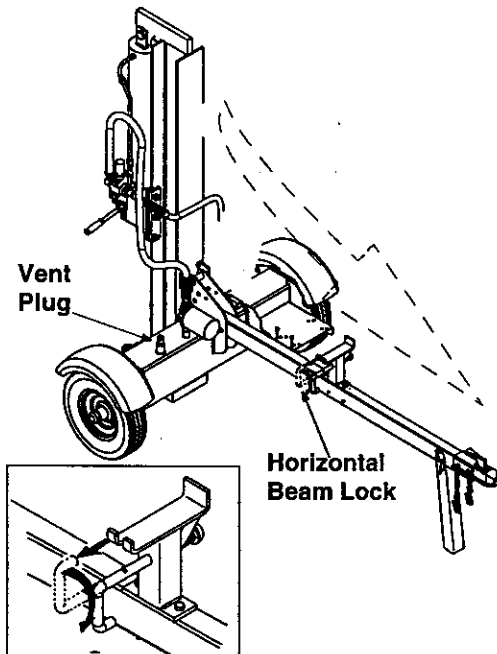

Figure 5

Final Assembly

Tire Pressure

The tires may have been over-inflated for shipping purposes. Maximum tire pressure should not exceed 30 p.s.i. Check tire pressure regularly.

Preparing the Engine

- Place the log splitter on a firm, level surface.
- Check engine oil as instructed on page 10.
- Fill engine with gasoline as instructed on page 10.

Preparing the Log Splitter

- Lubricate the beam area where the splitting wedge will slide with engine oil (*do not use grease*). Make certain to oil both front and back of the beam face.
- Remove reservoir vent plug. See Figure 6.

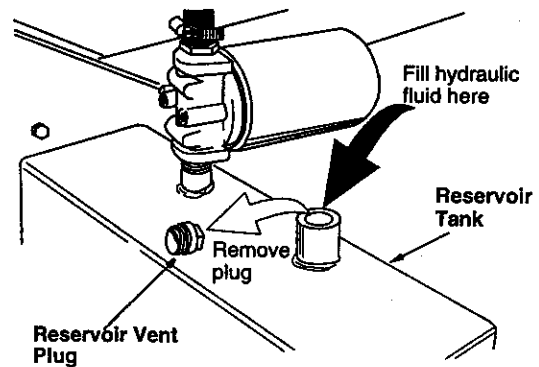

Figure 6

- Fill the reservoir tank to about 2" from the top with Dexron III automatic transmission fluid, or 10W non-foaming hydraulic fluid. Replace vent plug securely.
- Disconnect the spark plug wire. Prime the pump by pulling the recoil starter as far as it will go. Repeat approximately 10 times.
- Reconnect the spark plug wire and start engine. Refer to starting instructions on page 11.
- Use the control handle to engage the wedge to the far extended position. Refer to Figure 8.
- Retract the wedge.
- Refill tank to within 1-1/2" to 2" from the top of the tank.
- Extend and retract the wedge 12 complete cycles to remove trapped air in the system (system is "self-bleeding").
- Refill the reservoir to within 1-1/2" to 2" from the top of the tank. Much of the original fluid has been drawn into the cylinder and hoses. Make certain to refill the reservoir, to prevent extreme damage to the hydraulic pump.

NOTE: Some fluid may overflow from the vent plug as the system builds heat and the fluid expands and seeks a balanced level.

- Move control handle BACK or UP to return the wedge. See Figure 8 on page 10.

OPERATIONS

Know Your Log Splitter



Read this owner's manual and safety rules before operating your log splitter. Compare the illustrations on this page with your equipment to familiarize yourself with the location of various controls and adjustments. Save this manual for future reference. The operation of any log splitter can result in foreign objects being thrown into the eyes, which can result in severe eye damage. **Always wear safety glasses**, for operating your log splitter, or while performing any adjustments or repairs on it.

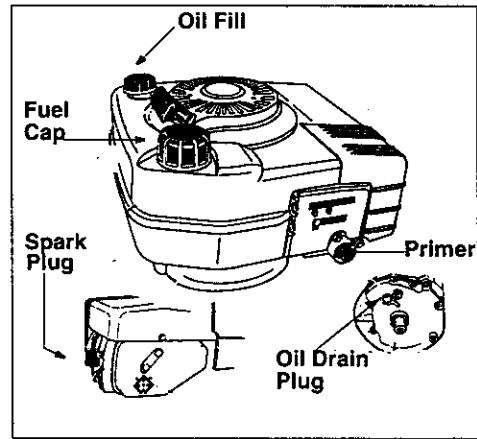
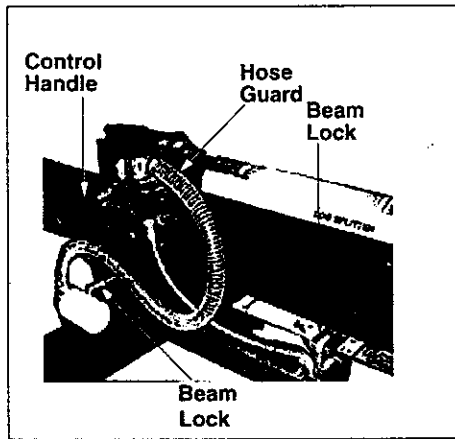
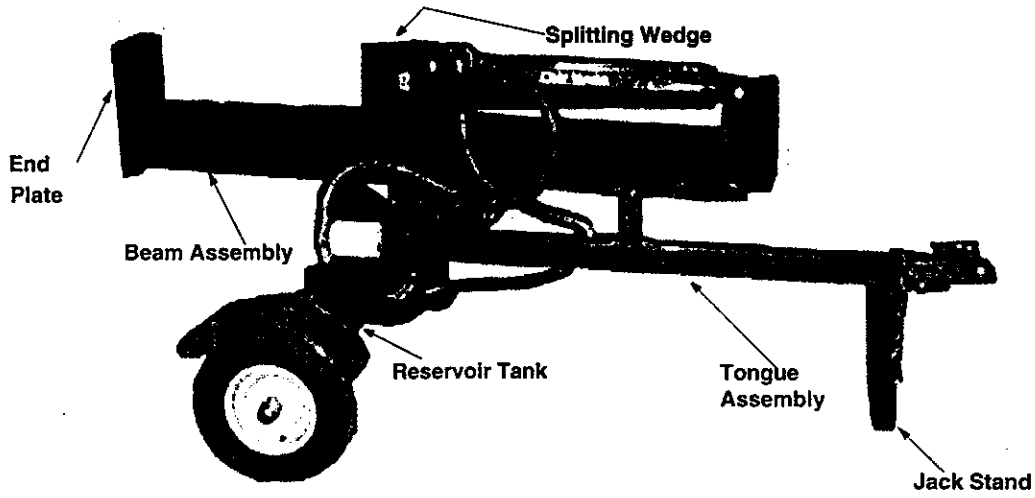

Figure 7

MEETS ANSI SAFETY REQUIREMENTS

Sears log splitters conform to the safety standards B71.7-1985 of the American National Standards Institute.

Operating Controls

(See Figure 7.)



WARNING: Before using your log splitter, again refer to the **safety rules on page 3, 4, and 5** of this manual. **Always be careful.**

Do not operate the log splitter without the proper amount of hydraulic oil in the reservoir tank. Failure to refill the tank will void your warranty.

Beam Locks

Used to secure the beam in the horizontal or the vertical position. There are two beam locks, one for each operating position. The vertical beam lock is located next to the oil filter. The horizontal beam lock is located on the beam support latch racket.

Primer

Used to start a cold engine. Do not use it to restart a warm engine after a short shut-down.

Starter Handle

Used to manually start the engine.

Control Handle

The control handle has three positions. See Figure 8.

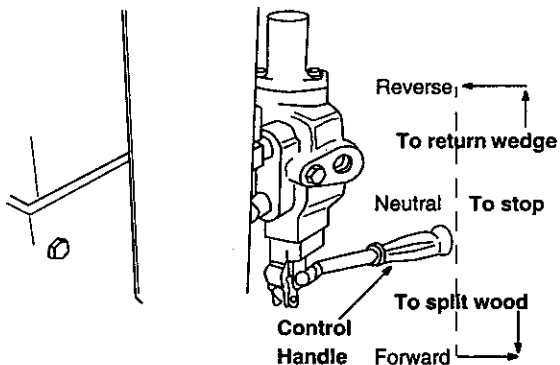

Figure 8

- Move control handle FORWARD or DOWN to move wedge down to split wood.

NOTE: Control handle will return to neutral position as soon as handle is released.

- Release the control handle to stop the wedge movement.
- Move control handle BACK or UP to return the wedge.

Stopping Engine

- Move throttle control lever to STOP position.
- Disconnect spark plug wire and move away from spark plug to prevent accidental starting while equipment is unattended.

Before Starting

Oil Fill-Up

- Only use high quality detergent oil rated with API service classification SF, SG or SH. Select the oil's viscosity grade according to the expected operating temperature. Follow the chart below.

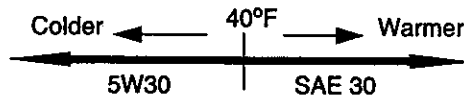

NOTE: Although multi-viscosity oils (5W30, 10W30, etc.) improve starting in cold weather, these multiviscosity oils will result in increased oil consumption when used above 40°F. Check the oil level more frequently to avoid possible engine damage from running low on oil.



WARNING: SAE 30 oil, if used below 40°F, will result in hard starting and possible engine bore damage due to inadequate lubrication.

Fill engine with the appropriate oil as follows:

- Remove oil fill dipstick.
- With log splitter on level ground, use a funnel to fill engine oil to FULL mark on dipstick. Capacity is approximately 1.25 pints or 21 ounces. Be careful not to overfill.
- Replace the dipstick on to the engine and tighten. Then remove the dipstick again and wipe off the oil from the end of the dipstick with a clean cloth.
- Screw the dipstick firmly back to place. Remove to check the oil level.
- Refill oil to FULL mark on dipstick if necessary. Replace dipstick and tighten.



WARNING: To avoid engine damage, never run engine unless oil level is between FULL and Add marks on the dipstick.

Gasoline Fill-Up

- Remove fuel cap.
- Make certain the gasoline container is clean and free from rust or foreign particles. Never use gasoline that may be stale from long periods of storage in the container.
- Fill fuel tank with about 1.5 quarts of clean, fresh, lead-free grade automotive gasoline. DO NOT use Ethyl or high octane gasoline.

NOTE: DO NOT use gasoline containing methanol. Gasoline containing up to about 10% ethanol or up to 15% methyl tertiary butyl ether (MTBE) may be used, but will require special care when engine is left unused for extended period. Refer to Storage instructions on page 18.

- Replace fuel cap.



WARNING: Do not fill closer than 1/2 inch of top of fuel tank to prevent spills and to allow for fuel expansion. If gasoline is accidentally spilled, move log splitter away from area of spill. Avoid creating any source of ignition until gasoline vapors have disappeared.

Starting Engine

- Attach spark plug wire and rubber boot to the spark plug.
- Place the throttle control lever in START position.
- Push the primer three times. wait about two seconds between each push. In cold weather with temperatures below 55° F, prime engine five times.
- Grasp the starter handle and pull rope out slowly until engine reaches start of the compression cycle (rope will pull slightly harder at this point). Let the rope rewind slowly.
- Pull rope with a rapid, continuous, full arm stroke. Keep a firm grip on the starter handle. Let rope rewind slowly. Do not let starter handle snap back against starter.

NOTE: If engine does not fire after three attempts, repeat above instructions.

Stopping Engine

- Move throttle control lever to STOP position.
- Disconnect spark plug wire and move away from spark plug to prevent accidental starting while equipment is unattended.

Raising and Lowering Beam

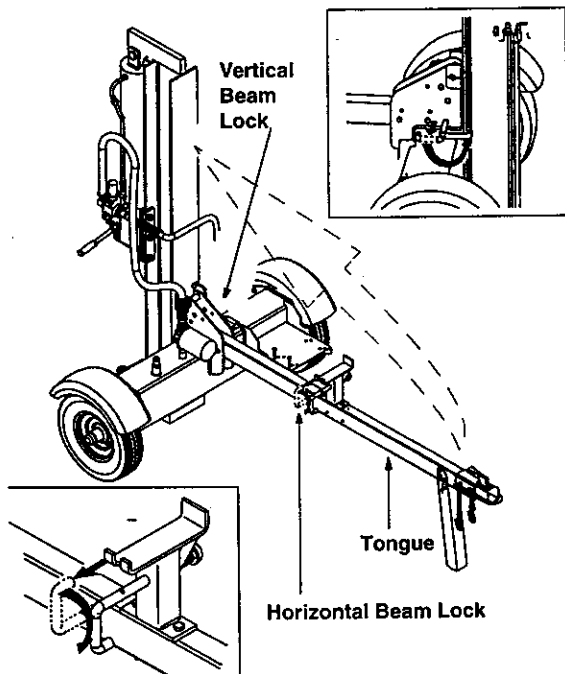

Figure 9

- Use control handle to run wedge up and down beam 6 to 8 times to circulate the hydraulic fluid, which will warm and thin the fluid.
- Place log splitter on a firm, level surface.
- **To raise the beam:** Pull out the beam lock on the tongue and pivot it down to release the beam.
- Move the beam to the vertical position. Secure it with the beam lock on the reservoir tank assembly. See Figure 9.
- **To lower the beam:** Pull out the beam lock on the reservoir tank.
- Pivot beam lock down to release the beam. Carefully pull back on beam and lower it to the horizontal position. See Figure 9.
- Pull out the beam lock on the tongue, pivot it upwards and release it to hold the beam. Make certain it is latched securely.



WARNING: Always use the log splitter in the vertical position only when splitting heavy logs.

Operating Position

Vertical

- Pull the horizontal beam lock out and pivot it down to release the beam. Pivot the beam to the vertical position.
- Lock the beam in the vertical position, by pulling out on the vertical beam lock and pivoting it to the left. See Figure 10.
- Stand in front of the log splitter. Operate the control handle with your right hand and stabilize the log, if necessary, with your left hand. See Figure 10.

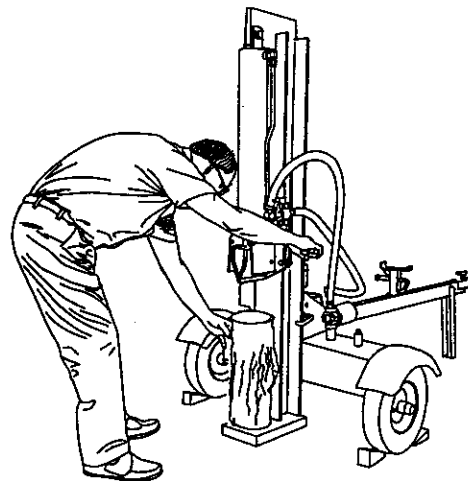

Figure 10

Horizontal

- Pull the vertical beam lock out and pivot it down. Pivot the beam to the horizontal position.
- Lock the beam in the horizontal position, by pulling out on the horizontal beam lock and pivoting it upwards.

- Stand behind the reservoir tank. See Figure 11. Operate the control handle with your right hand and stabilize the log, if necessary, with your left hand.

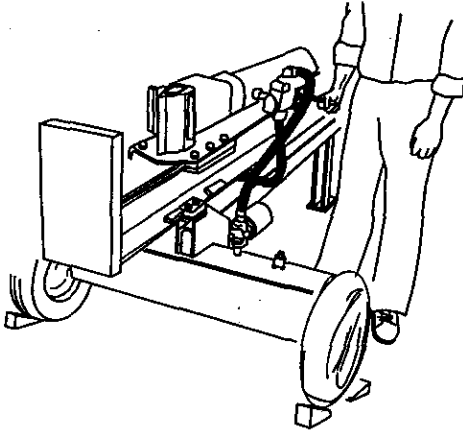

Figure 11

Before Each Use

- Remove the vent plug and check hydraulic fluid level. Refill if necessary.
- Check engine oil level. Refill if necessary.
- Fill up gasoline if necessary.
- Lubricate with engine oil the beam area where splitting wedge will slide. Do not use grease to lubricate. Make sure to lubricate both the front and the back of the beam face.
- Attach spark plug wire to the spark plug.

Operating the Log Splitter



WARNING: Wear leather work gloves, safety shoes and safety glasses to operate the log splitter. Watch your footing during operation and while handling the log.

- Place the log splitter on a dry, firm, level surface.
- Block the front and back of the wheels when operating (and when storing) to prevent it from moving or rolling away.
- Lock in either the horizontal or vertical position.
- Set the engine throttle at maximum speed.
- Place the log against the end plate. Only split wood in the direction of the grain.
- Stabilize the log, when needed, by holding the sides of the log with your free hand. **Never** place your hands between the log and the splitting wedge.
- **Only one adult should stabilize the log and operate the control handle** so that the operator has full control over the log and the wedge.



WARNING: If the hydraulic fluid becomes very hot at any time during the operation, stop the unit and **allow the fluid to cool down**. Otherwise the performance of your log splitter will be affected.

Transporting the Log Splitter

- Lower the beam to its horizontal position. Make certain the beam is locked securely with the horizontal beam lock.
- Raise or lower jack stand to attach the hitch to a towing vehicle. Make certain to latch securely.
- Remove spring pin and clevis pin securing the jack stand to the tongue assembly and pivot the jack stand to transport position. Secure with hardware just removed.
- Attach the safety chains to the towing vehicle. Refer to Page 3.

MAINTENANCE

Maintenance Schedule		Before each use	First five hours	Every 25 hours	Every 50 Hours	Every 100 hours	Fill in service dates here				
Splitter Mechanism	Check hydraulic fluid	✓									
	Change hydraulic fluid				✓						
	Change hydraulic filter			✓							
	Check hose clamps	✓									
	Lubricate beam and wedge	✓									
Engine	Check engine oil	✓									
	Change engine oil		✓	✓							
	Service air cleaner				✓						
	Clean engine	✓									
	Service spark plug				✓						
	Clean engine linkages			✓							

MAINTENANCE

General Recommendations

- Always observe safety rules when performing any maintenance.
- The warranty on this log splitter does not cover items that have been subjected to operator abuse or negligence. To receive full value from the warranty, operator must maintain the log splitter as instructed in this manual.
- Some adjustments will need to be made periodically to maintain your unit properly.
- All adjustments in the Service and Adjustments section of this manual should be checked at least once each season.
- Follow the maintenance schedule given above.
- Periodically check all fasteners and make sure these are tight.



WARNING: Always stop the engine and disconnect spark plug wire before performing any maintenance or adjustments.

Splitter Mechanism

Hydraulic Fluid

- Check the hydraulic fluid level in the log splitter reservoir tank before each use. Fluid level should

be 1.5" to 2" from the top of the tank (four gallons approximately).

- Change the hydraulic fluid in the reservoir every 100 hours of operation.
- Disconnect the suction hose from the bottom of the reservoir tank, and drain the fluid into a suitable container.
- Refill using only Dexron III automatic transmission fluid or 10W non-foaming hydraulic fluid. Also, make certain to change the hydraulic filter.

NOTE: Drain the fluid and flush the reservoir tank and hoses with kerosene whenever any repair work is performed on the tank, hydraulic pump or valve. Contaminants in the fluid will damage the hydraulic components. Repairs to hydraulic components should be performed by a Sears service center.

Hydraulic Filter

- Change the hydraulic filter every 50 hours of operation. Use only a 10 micron hydraulic filter.

Hose Clamps

- Check the hose clamps on the suction hose (attached to the side of the pump) for proper tightness before each use.

- Check the hose clamps on the return hose at least once a season.

Beam And Splitting Wedge

- Lubricate both sides of the beam where it contacts the splitting wedge with engine oil before each use to obtain years of service. However, normal wear will occur.
- Periodically check the bolts on the side of the wedge plate to eliminate excess space between the wedge plate and the beam.
- The wedge plate on the log splitter is designed so the gib blocks on the side of the wedge plate can be easily removed and rotated or turned over for even wear. You can locate these two gib blocks behind the gib plate shown in the figure below. Make certain to readjust the adjustment bolts so wedge moves freely, but no excess space exists between the wedge plate and beam. See Figure 12.

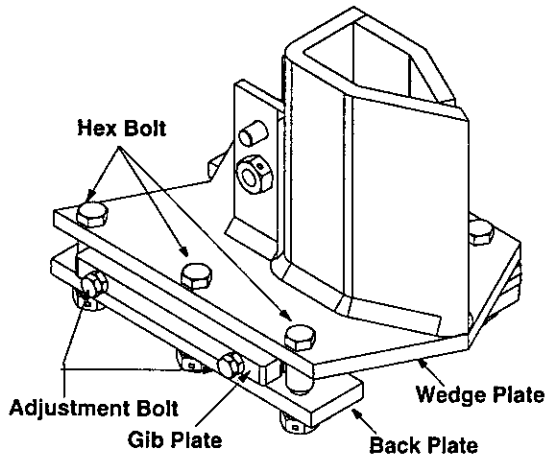

Figure 12

Engine

Changing engine oil

- Only use high quality detergent oil rated with API service classification SF, SG or SH. Select the oil's viscosity grade according to the expected operating temperature. Refer to page 10 of this manual for viscosity chart.
- Stop engine and wait several minutes before checking oil level. With engine on level ground, the oil must be to FULL mark on dipstick.
- Change engine oil after the first five hours of operation, and every 25 hours thereafter. Change oil more frequently if the engine is operated under heavy load, or in high ambient temperatures.

Drain oil while engine is warm. Follow the instructions given below.

- Remove oil drain plug and dipstick. Catch oil in a suitable container.

- When engine is drained of all oil, replace drain plug securely.
- Refill with fresh oil. Refer to GAS AND OIL FILL-UP section of this manual.
- Replace dipstick.

Service air cleaner

The air cleaner prevents damaging dirt, dust, etc., from entering the carburetor and being forced into the engine and is important to engine life and performance. The air cleaner consists of a paper pre-cleaner and a foam filter cartridge.



WARNING: Never run your engine without air cleaner completely installed on engine.

- Replace paper pre-cleaner once a year or every 100 operating hours. Replace more frequently if operating under dusty conditions. Replacement filters are available at any Sears service center. **Do not attempt to clean or oil the paper pre-cleaner element.**
- Service cartridge every three months or every 25 operating hours. Service cartridge more often under dusty conditions.
- **To service foam cartridge:** Loosen air cleaner cover screws. Do not remove screw from cover. Swing cover down to remove from hinge. See Figure 13.

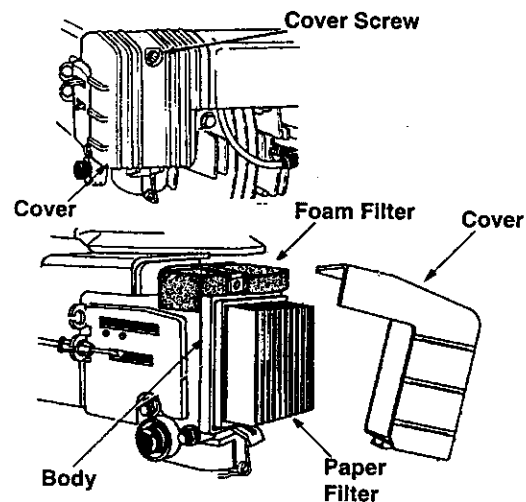

Figure 13

- Inspect filter for discoloration or dirt accumulation. If either is present, proceed as follows.
- Clean inside of body and cover thoroughly.
- Remove foam cartridge. Wash in liquid detergent and water. Squeeze dry in a clean cloth. Saturate in engine oil. Squeeze (don't twist) in a clean, absorbent cloth to remove all excess oil.
- Reassemble foam cartridge and paper pre-cleaner in the body. Swing cover down and tighten the two screws loosened earlier.



WARNING: Temperature of muffler and nearby areas may exceed 150° F(65°C). Avoid these areas.

Clean engine

- Clean engine periodically. Remove dirt and debris with a cloth or brush. *Cleaning with a forceful spray of water is not recommended as water could contaminate the fuel system.*
- To ensure smooth operation of the engine, keep the governor linkage, springs and controls free of debris. See Figure 14.
- Every 100 hours of operation, remove combustion deposits from top of cylinder, cylinder head, top of piston and around valves.

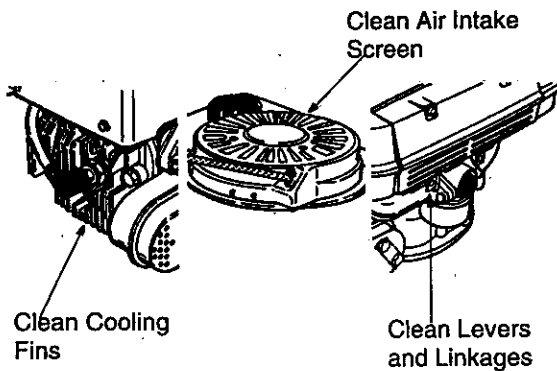

Figure 14

Spark Plug

- Clean spark plug and reset the gap to .030" at least once a season or every 50 hours of operation. See Figure 15. Spark plug replacement is recommended at the start of each season. Refer to engine parts list for correct spark plug type.

NOTE: Do not sandblast spark plug. Spark plug should be cleaned by scraping or wire brushing and washing with a commercial solvent.

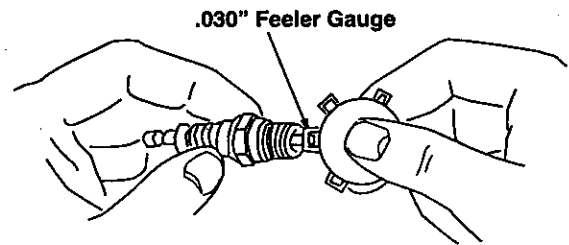

Figure 15

SERVICE & ADJUSTMENTS



WARNING: Always stop engine, disconnect spark plug wire, and move it away from spark plug before performing any adjustments or repairs.

Tires

- See sidewall of tire for recommended pressure. Maximum tire pressure under any circumstances is 30 p.s.i. Equal tire pressure should be maintained on all tires.



WARNING: Excessive pressure (over 30 p.s.i.) when seating beads may cause tire/rim assembly to burst with force sufficient to cause serious injury.

Flexible Pump Coupler

The flexible pump coupler is a nylon "spider" insert, located between the pump and engine shaft. Over a period of time, the coupler will harden and deteriorate. Replace the coupler if you detect vibration or noise in the area between the engine and the pump. If the coupler fails completely, you will experience a loss of power.



WARNING: Never hit the engine shaft in any manner, as a blow will cause permanent damage to the engine.

IMPORTANT: If you do not have the right tools or are otherwise uncomfortable with the procedure, contact Sears service center.

When replacing the flexible pump coupler, proceed as follows. Follow the instructions carefully as the alignment is critical.

- Disconnect the spark plug wire, and secure it away from the spark plug.
- Drain gasoline from fuel tank or place a piece of plastic film underneath the gas cap to prevent gasoline from leaking.
- Using a 1/2 inch socket with an extension, remove the three bolts securing the engine to the engine mounting bracket. The three bolts can be found under the engine mounting bracket.
- Carefully lift engine off mounting bracket and set aside on a sturdy, level surface.
- Remove the nylon spider insert from the pump shaft. You may need a pair of needle nose pliers to grasp the insert.
- Place a new "spider" insert into the pump coupling half. See Figure 16,1. Make sure the key is on the pump shaft. The key way in the lower coupling half has to fit over the key on the pump shaft.
- Re-seat the engine making sure to align the pump and engine coupling halves. There must

be space between end of the engine and the coupling half. See Figure 16,2.

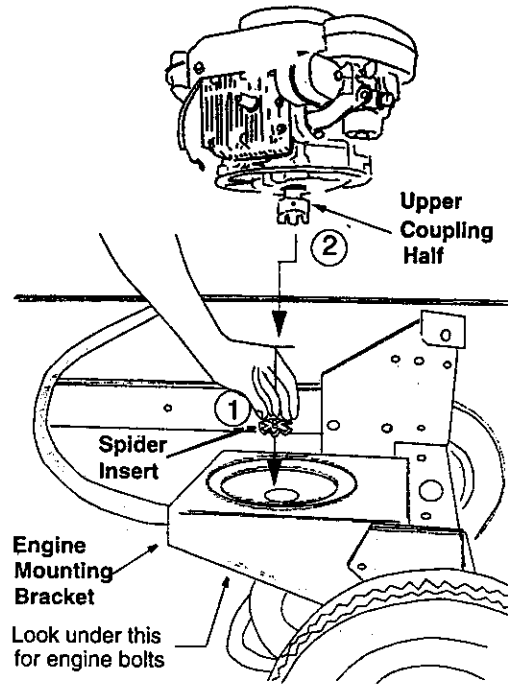

Figure 16

NOTE: The pump coupling half can be rotated by hand to aid in alignment. If the two parts are not aligned the unit will not operate properly and damage could occur.

- Set .035-.060 inch clearance between the coupling halves by sliding a matchbox cover between the jaws of the upper and the lower coupling halves.

NOTE: Before securing the set screw, apply some Loctite™ on the threads of the screw.

- Tighten the set screw to 78 inch-pounds torque.
- Secure engine with three bolts removed earlier. Torque bolts to 200 to 450 inch-pounds.
- Reattach spark plug wire to spark plug. Be sure to remove plastic film from under gas cap if necessary.

Beam & Splitting Wedge

The wedge plate is subject to normal wear. Periodically adjust the bolts on the wedge plate making sure that the wedge moves freely. Also make sure that no excess space exists between the wedge plate and the beam.

To adjust:

- Loosen three hex bolts on top of the wedge plate (beneath the splitting wedge). See Figure 17.
- Loosen the lock nuts on the two adjustment bolts on the side of the gib plate, located beneath the splitting wedge. See Figure 17. Turn the adjustment bolts in until snug, then back them off **slowly** until the wedge assembly will slide on the beam.
- Tighten the lock nuts securely against the gib plate to hold adjustment bolts in this position.
- Retighten the three hex bolts on top of the wedge plate.

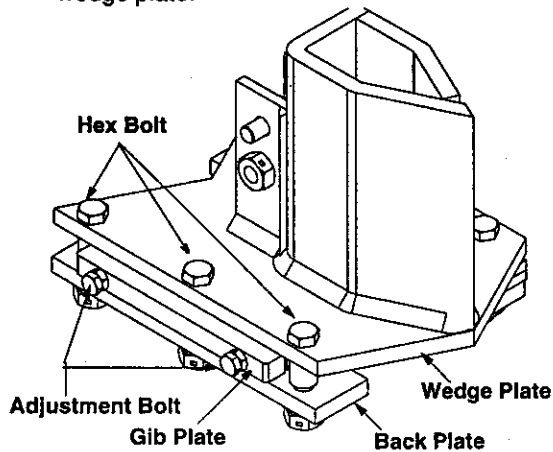

Figure 17

To replace:

Periodically remove and replace the "gibs" (spacers) between the wedge plate and the back plate as follows.

NOTE: If desired, the gibs may be rotated and/or turned over for even wear.

- Remove the center bolt on top of the wedge plate. Slide the gib plate out. See Figure 17.
- Remove and replace the gibs. Reassemble the gib plate, making certain flat washer is in place under the gib plate.

Readjust the bolts on the side of the wedge plate as instructed previously.

Adjusting Carburetor



WARNING: If you make any adjustments to the engine while it is running, **keep clear of all moving parts** to avoid injury. Be careful of **heated surfaces** and muffler.

If the engine carburetor needs adjustment, contact your nearest Sears service center.

Engine performance may be affected in altitudes above 4,000 feet. To improve engine performance, install a high altitude adjustment kit. This kit is available at Sears service centers.

Engine Speed

The engine speed on your log splitter has been set by the engine manufacturer. Do not attempt to increase engine speed or it may result in personal injury. If you believe the engine is running too fast or too slow, contact Sears service center for repair and adjustment.



IMPORTANT: Changing of engine governed speed by the customer will void engine warranty.

STORAGE

Prepare your log splitter for storage at the end of the season or if the log splitter will not be used for 30 days or more.



WARNING: Never store machine with fuel in the fuel tank inside of building where fumes may reach an open flame or spark, or where ignition sources are present such as hot water and space heaters, furnaces, clothes dryers, stoves, electric motors, etc.

NOTE: A yearly check-up by your local Sears Service Center is a good way to make certain your log splitter will provide maximum performance for the next season.

LOG SPLITTER

- Clean the log splitter thoroughly.
- Wipe unit with an oiled rag to prevent rust, especially wedge and beam.

ENGINE

IMPORTANT: It is important to prevent gum deposits from forming in essential fuel system parts such as carburetor, fuel filter, fuel hose, or tank during storage. Also, experience indicates that alcohol blended fuels (called gasohol or using ethanol or methanol) can attract moisture which leads to separation and formation of acids during storage. Acidic gas can damage the fuel system of an engine while in storage.

- Drain the fuel tank.
- Start the engine and let it run until the fuel lines and carburetor are empty.
- Drain carburetor by pressing upward on bowl drain which is located below the carburetor.

- Never use engine or carburetor cleaner products in the fuel tank or permanent damage may occur.
- Use fresh fuel next season.

NOTE: Fuel stabilizer is an acceptable alternative in minimizing the formation of fuel gum deposits during storage.

- Add stabilizer to gasoline in fuel tank or storage container.
- Always follow the mix ratio found on stabilizer container.
- Run engine at least 10 minutes after adding stabilizer to allow the stabilizer to reach the carburetor.
- Do not drain the gas tank and carburetor if using fuel stabilizer. Drain all the oil from the crankcase (this should be done after the engine has been operated and is still warm) and refill the crankcase with fresh oil.
- If you have drained the fuel tank, protect the inside of the engine as follows.
- Remove spark plug, pour approximately 1/2 ounce (approximately one tablespoon) of engine oil into cylinder and crank slowly to distribute oil.
- Replace spark plug.

OTHER

- Do not store gasoline from one season to another.
- Replace your gasoline can if it starts to rust. Rust and/or dirt in the gasoline will cause problems. Store unit in a clean, dry area. Do not store next to corrosive materials, such as fertilizer.

NOTE: If storing in an unventilated or metal storage shed, be certain to rustproof the equipment by coating with a light oil or silicone.

TROUBLESHOOTING

Problem	Possible Cause	Corrective Action
Cylinder rod will not move	<ol style="list-style-type: none"> 1. Broken Drive shaft. 2. Shipping plugs left in hydraulic hoses. 3. Set screws in coupling not adjusted properly. 4. Loose shaft coupling. 5. Gear sections damaged. 6. Damaged relief valve. 7. Hydraulic lines blocked. 8. Incorrect oil level. 9. Damaged or blocked directional valve. 	<ol style="list-style-type: none"> 1. Return unit to Sears service center. 2. Disconnect hydraulic hose, remove shipping plugs, and reconnect hose. 3. Refer to adjustment section of this manual and adjust the couplers 4. Correct engine/pump alignment. 5. Return unit to Sears service center. 6. Return unit to Sears service center. 7. Flush and clean hydraulic system. 8. Check oil level. Refill if necessary. 9. Return unit to Sears service center
Cylinder shaft speed slow while extending and retracting	<ol style="list-style-type: none"> 1. Gear sections damaged. 2. Excessive pump inlet vacuum. 3. Slow engine speed. 4. Damaged relief valve. 5. Incorrect oil level. 6. Contaminated oil. 7. Directional valve leaking internally. 8. Internally damaged cylinder. 	<ol style="list-style-type: none"> 1. Return unit to Sears service center. 2. Make certain that the pump inlet hoses are clear and unblocked. Use short, large diameter inlet hoses. 3. Return unit to Sears service center. 4. Return unit to Sears service center. 5. Check oil level. Refill if necessary. 6. Drain oil, clean reservoir, refill, make certain oil return tube is below oil level. 7. Return unit to Sears service center. 8. Return unit to Sears service center.
Engine runs but wood will not split, or splits too slowly	<ol style="list-style-type: none"> 1. Small gear section damaged. 2. Pump check valve leaking. 3. Excessive vacuum in pump inlet. 4. Incorrect oil level. 5. Contaminated oil. 6. Directional valve leaking internally. 7. Internally damaged cylinder. 8. Overloaded cylinder. 	<ol style="list-style-type: none"> 1. Return unit to Sears service center. 2. Return unit to Sears service center. 3. Make certain that the pump inlet hoses are clear and unblocked. Use short, large diameter inlet hoses. 4. Check oil level. Refill if necessary. 5. Drain oil, clean reservoir, refill, make certain oil return tube is below oil level. 6. Return unit to Sears service center. 7. Return unit to Sears service center. 8. Do not attempt to split wood against the grain.
Engine stalls during splitting wood	<ol style="list-style-type: none"> 1. Low horsepower/weak engine. 2. Overloaded cylinder 	<ol style="list-style-type: none"> 1. Return unit to Sears service center. 2. Do not attempt to split wood against the grain. If engine stalls repeatedly, contact Sears service center.
Engine will not turn or stalls under low load	<ol style="list-style-type: none"> 1. Engine/pump misaligned. 2. Frozen or seized pump. 3. Weak engine. 4. Hydraulic lines blocked. 5. Blocked directional valve. 	<ol style="list-style-type: none"> 1. Correct alignment. 2. Return unit to Sears service center. 3. Return unit to Sears service center. 4. Flush and clean hydraulic system. 5. Return unit to Sears service center
Leaking pump shaft seal	<ol style="list-style-type: none"> 1. Broken drive shaft. 2. Engine/pump misaligned. 3. Gear sections damaged. 4. Poorly positioned shaft seal. 5. Oil breather plugged. 	<ol style="list-style-type: none"> 1. Return unit to Sears service center. 2. Correct alignment. 3. Return unit to Sears service center. 4. Return unit to Sears service center. 5. Make certain reservoir is properly vented.

Troubleshooting Guide continued

Problem	Possible Causes	Corrective Action
Engine fails to start	<ol style="list-style-type: none"> 1. Dirty air cleaner. 2. Fuel tank empty, or stale fuel. 3. Blocked fuel line. 4. Spark plug wire disconnected. 5. Faulty spark plug. 	<ol style="list-style-type: none"> 1. Service air cleaner following instructions on page 14 of this manual. 2. Fill tank with fresh fuel. 3. Clean fuel line. 4. Connect spark plug wire to spark plug. 5. Service spark plug following instructions on page 15.
Engine runs erratic.	<ol style="list-style-type: none"> 1. Spark plug wire loose. 2. Blocked fuel line or stale fuel. 3. Dirty air cleaner. 4. Carburetor out of adjustment 	<ol style="list-style-type: none"> 1. Connect and tighten spark plug wire. 2. Clean fuel line. Fill tank with fresh fuel. 3. Service air cleaner following instructions on page 14. 4. Contact Sears service center.
Engine overheats	<ol style="list-style-type: none"> 1. Engine oil level low. 2. Dirty air cleaner. 3. Carburetor out of adjustment. 4. Air flow restricted. 	<ol style="list-style-type: none"> 1. Fill crankcase with proper oil. 2. Service air cleaner following instructions on page 14. 3. Contact Sears service center. 4. Stop engine, disconnect spark plug wire, move blower housing, and clean.
Will not split logs	<ol style="list-style-type: none"> 1. Reservoir fluid level low. 	<ol style="list-style-type: none"> 1. Refill with Dexron III automatic transmission fluid.
Leaking cylinder	<ol style="list-style-type: none"> 1. Broken seals. 2. Scored cylinder 	<ol style="list-style-type: none"> 1. Return unit to Sears service center. 2. Return unit to Sears service center.



For repairs beyond the minor adjustments listed above, please contact your nearest SEARS service center.

PARTS LIST

Craftsman 6.5 H.P. Log Splitter Model 247.794510

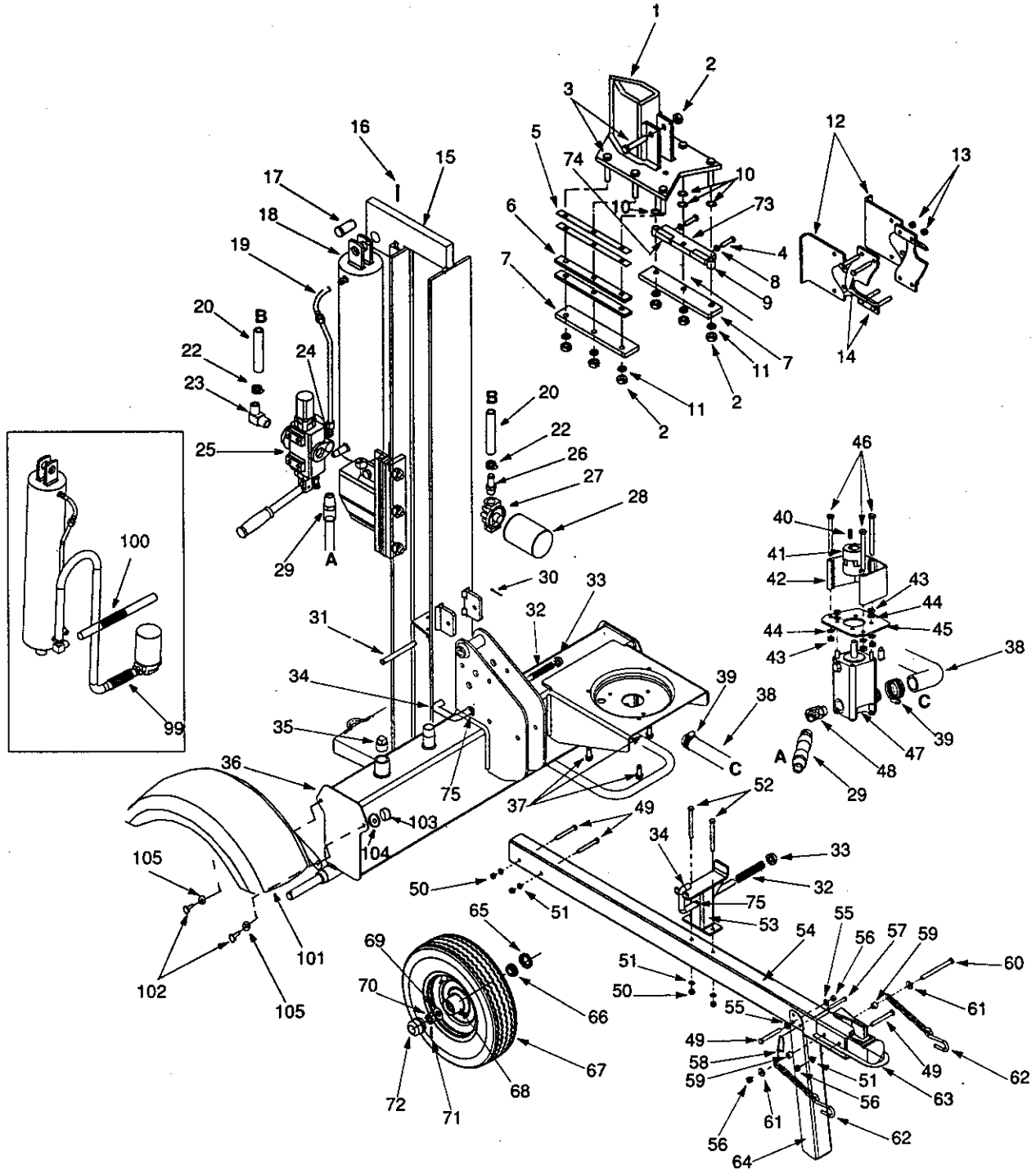

PARTS LIST

Craftsman 6.5 H.P. Log Splitter Model 247.794510

KEY NO.	PART NO.	DESCRIPTION	KEY NO.	PART NO.	DESCRIPTION
1	781-0323B	Wedge Asm	47	718-0476	Gear Pump (11 GPM)
2	712-0239	Lock Nut 1/2-20	48	737-0329	45 Degree Elbow
3	710-1018	Hex Cap Screw 1/2-20 x 2.75	49	710-0521	Hex Bolt 3/8-16 x 3" Lg.
4	710-0459A	Hex Cap Screw 3/8-24 x 1.5	50	712-0798	Hex Nut 3/8-16 Thd.*
5	781-0352A	Adjustable Gib Shim	51	736-0169	L-Wash. 3/8" I.D.*
6	781-0350A	Fixed Gib	52	710-0411	Hex Bolt 3/8-16 x 4" Lg.
7	781-0537	Back Bracket	53	781-0398	Support Beam Asm
8	712-3001	Hex Jam Nut 3/8-24	54	781-0680A	Tube
9	750-0750	Spacer	55	736-0185	Flat Washer 3/8
10	736-0192	Flat Washer .531 x .93 x .090	56	712-0375	Hex L-Nut 3/8-16 Thd.
11	736-0921	Lock Washer 1/2	57	711-0813	Clevis Pin 5/16 x 2.5" Lg.
12	781-0168A	Stripper Side	58	732-0194	Spring Pin
13	712-0130	Lock Nut 3/8-16	59	750-0497	Spacer 3/8" I.D. x .625" O.D.
14	710-0859	Hex Cap Screw 3/8-16 x 2.5	60	710-0944	Hex Bolt 3/8-16 x 4" Lg. (Grd 5)
15	681-0126	Beam Asm	61	736-0262	Fl-Wash. 3/8" I.D. x .87" O.D.
16	714-0211	Cotter Pin	62	713-0433	Chain—Tow Hitch
17	711-1135	Clevis Pin	63	727-0311	Hitch Coupler
18	718-0306	Hydraulic Cylinder	64	781-0162	Jack Stand
19	727-0471	Hydraulic Tube	65	721-0168	Bearing Seal Only
20	727-0443	Return Hose 3/4" I.D. x 44" Lg.	66	741-0987	Bearing Cone
22	726-0132	Hose Clamp 5/8"	67	634-0186	Wheel Asm Comp. - Gray
23	737-0153	Return Elbow		734-0872	Tire 16 x 4.8
24	737-0192	90° Solid Male Adapter		634-0188	Rim Asm - Gray
25	718-0481	Control Valve		734-0255	Air Valve
26	737-0235	3/4" Hose Adapter	68	741-0988	Bearing Cup
27	737-0306	Filter Housing	69	736-0351	Fl-Wash. .76" I.D. x 1.5" O.D.
28	723-0405	Oil Filter	70	712-0359	Slotted Nut 3/4-16 Thd.
29	727-0502	High Pressure Hydraulic Hose	71	714-0162	Cotter Pin 5/32" Dia. x 1-1/4" Lg.
30	714-0470	Cotter Pin 1/8" Dia.	72	734-0873	Hub Cap
31	738-0805	Hinge Pin 1/2 x 4.8" Lg.	73	781-0356	Floating Gib Plate
32	732-0583	Comp. Spring 4" Lg.	74	781-0351	Adjustable Gib
33	726-0214	Push Cap	75	736-0116	Flat Washer .635 ID x .93 OD
34	781-0690	Locking Rod			
35	737-0236	Pipe Plug	97	—	Tecumseh Vertical Shaft Engine
36	681-0092A	Frame Asm			Model 143.995000(not shown)
37	710-0654A	Hex Washer Screw 3/8-16 x 1.0	98	770-10035	Owner's Manual
38	735-0256	Suction Hose			(not shown)
39	726-0174	Hose Clamp	99	781-0526	Hose Guard
40	714-0122	Sq.-Key 3/16" x .75"	100	781-0538	Hose Guard
41	718-0250A	Flexible Coupling	101	681-0138	Fender Assembly
42	719-0353	Coupling Shield	102	710-0157	Hex Bolt: 5/16-24 x 0.75" Gr.5
43	712-0123	Hex Nut 5/16-24	103	712-0123	Hex Nut 5/16-24
44	736-0119	L-Wash. 5/16" I.D.*	104	736-0119	Lock Washer 5/16
45	781-0097	Rear Coupling Support Bracket	105	736-0159	Flat Washer 5/16
46	710-1338	Hex Screw 5/16-24 x 3.25			

Tecumseh Engine model 143.99650

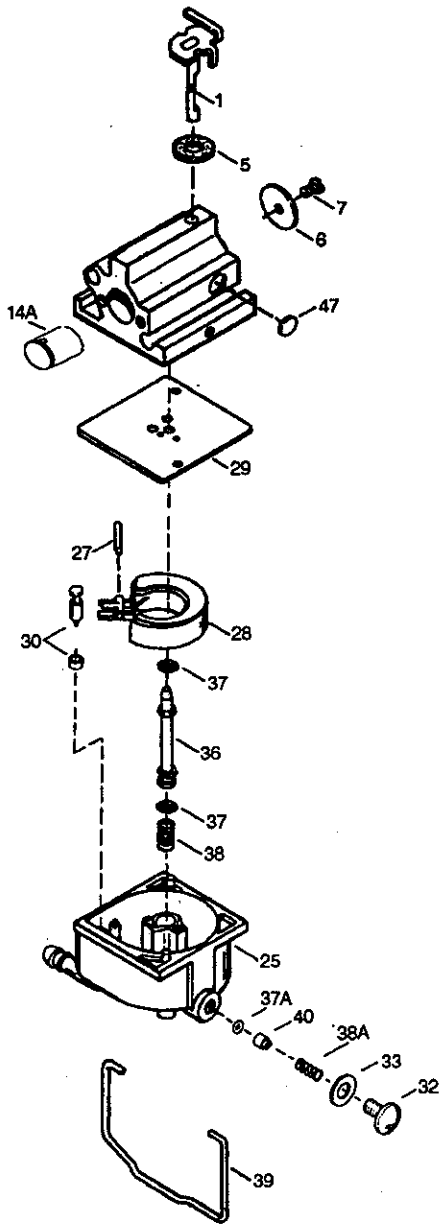

Key No.	Part No.	Description	Qty.
0	640020A	Carburetor (Incl. 187B & 239 of Engine Parts List)	1
1	632539	Throttle Shaft & Lever Assembly	1
5	632593	Dust Seal	1
6	632541	Throttle Shutter	1
7	650506	Throttle Shutter Screw	1
14A	632773	Venturi	1
25	632675A	Float Bowl	1
27	632544	Float Shaft	1
28	632543	Float	1
29	632548	Float Bowl to Body Gasket	1
30	632709	Inlet Needle & Seat	1
32	632672	Bowl Drain Screw	1
33	632673	Bowl Drain Washer	1
36	640022	Main Nozzle Tube	1
37	632547	"O" Ring	2
37A	632547	"O" Ring, Main Nozzle Tube	1
38	632545	Spring, Main Nozzle Tube	1
38A	632545	Spring	1
39	632549	Float Bowl Retainer	1
40	640021	Main Fuel Jet	1
44	27110	Bowl Nut Washer	1
47	632554	Welch Plug, Idle Mixture Well	1

Tecumseh Engine model 143.99650

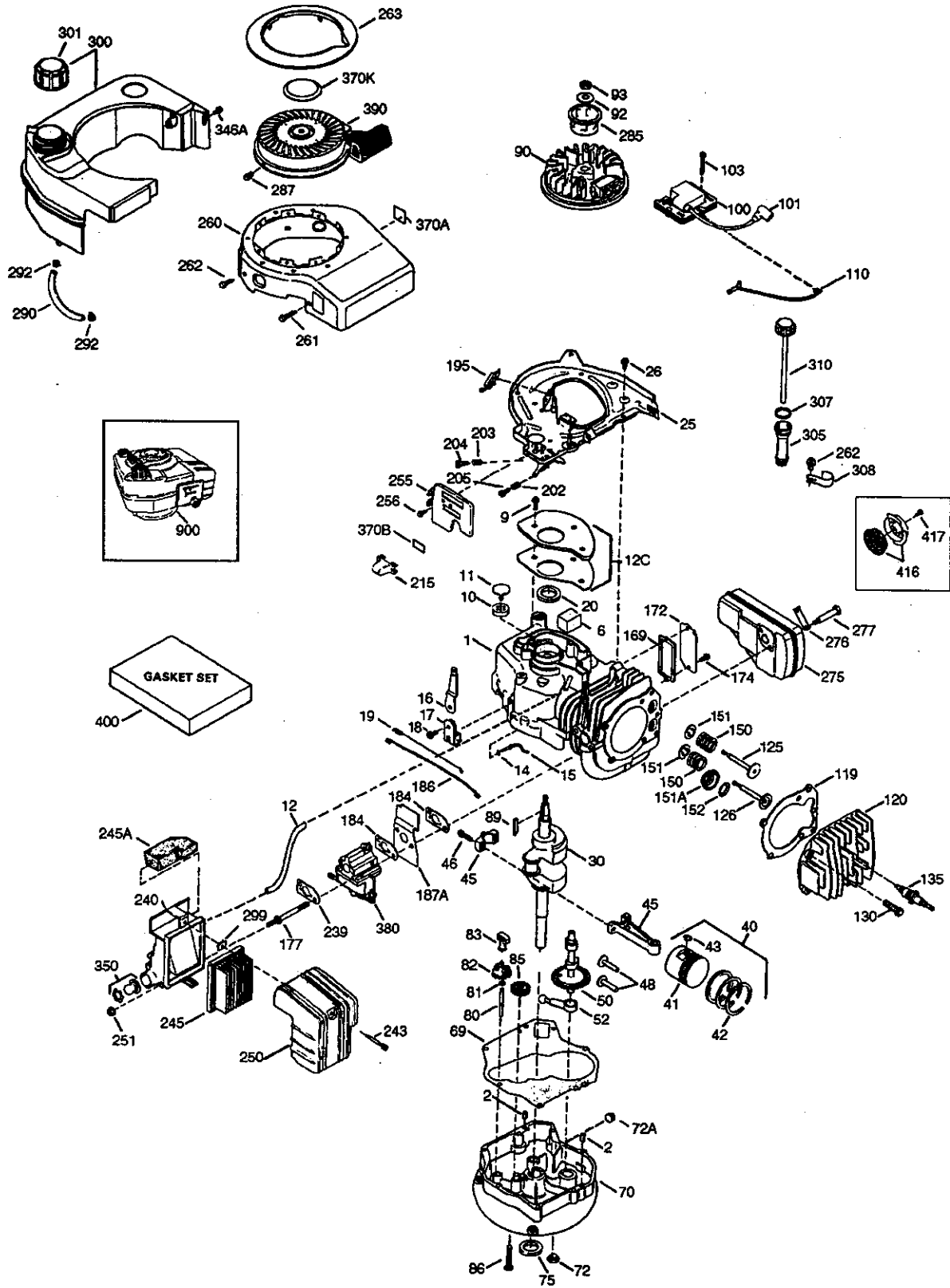

Tecumseh Engine model 143.99650

Key No.	Part No.	Description	Qty.	Key No.	Part No.	Description	Qty.
0		RPM High 3100 to 3400		86	650924	Screw, 1/4-20 x 1-9/16"	7
0		RPM Low 2000 to 2300		89	611154	Flywheel Key	1
1	36177	Cylinder (Incl. 2,10,12,20 & 125)	1	90	611170	Flywheel	1
2	27652	Dowel Pin	2	92	650815	Belleville Washer	1
6	36059	Breather Element	1	93	650816	Flywheel Nut	1
9	590568	Screw, 10-24 x 3/4"	3	100	34443B	Solid State Ignition	1
10	36002	Breather Valve Body	1	101	610118	Spark Plug Cover	1
11	36003A	Check Valve	1	103	651007	Screw, Torx T-15, 10-24 x 15/16"	2
12	32447	Breather Tube	1	110	36230	Ground Wire	1
12	36005A	Breather Cover & Gasket	1	119	36061	Cylinder Head Gasket	1
14	28277	Washer	1	120	36187	Cylinder Head	1
15	36006	Governor Rod (Machined)	1	125	36471	Exhaust Valve (Std.) (Incl. 151)	1
16	36008	Governor Lever	1	125	36472	Exhaust Valve (1/32" OS)	1
17	31335	Governor Lever Clamp	1	126	29314C	Intake Valve (Std.) (Incl. 151)	1
18	651018	Screw, Torx T-15, 8-32 x 19/64"	1	130	6021A	Screw, 5/16-18 x 1-1/2"	7
19	36103	Governor Spring	1	135	35395	Resistor Spark Plug (RJ19LM)	1
20	36010	Oil Seal	1	150	31672	Valve Spring	2
25	36145	Blower Housing Baffle (Incl.195)	1	151	31673	Lower Valve Spring Cap	2
26	650802	Screw, 1/4-20 x 5/8"	3	151A	40016A	Intake Valve Seal	1
30	36180	Crankshaft	1	152	37075	"O"-Ring	1
40	40004	Piston,Pin,Ring Set (Std.)	1	169	27234A	Valve Spring Box Gasket	1
40	40005	Piston,Pin,Ring Set (.010 OS)	1	172	32755	Valve Spring Box Cover	1
41	36070	Piston & Pin Ass'y.(Std.) (Incl. 43)	1	174	30200	Screw, 10-24 x 9/16"	2
41	36071	Piston & Pin Ass'y.(.010 OS)(Incl.43)	1	177	650925A	Carburetor Mounting Stud	2
42	40006	Ring Set (Std.)	1	184	36183	Carburetor Gasket	2
42	40007	Ring Set (.010 OS)	1	186	36009	Governor Link	1
43	20381	Piston Pin Retaining Ring	2	187A	37136	Air Baffle	1
45	36023A	Connecting Rod Ass'y. (Incl. 46)	1	195	610973	Terminal Ass'y.	1
46	32610A	Connecting Rod Bolt	2	202	36482	Compression Spring	1
48	36030	Valve Lifter	2	203	31342	Compression Spring	1
50	36031A	Camshaft (MCR)	1	204	651029	Screw, Torx T-10, 5-40 x 7/16"	1
52	29914	Oil Pump Ass'y.	1	205	651030	Screw, Torx T-10, 6-32 x 17/32"	1
69	36032A	Mounting Flange Gasket	1	215	36051	Control Knob	1
70	37271	Mounting Flange (Incl. 72 thru 85)	1	239	36048	Carburetor to Air Cleaner Gasket	1
72	36083	Oil Drain Plug	1	240	36044B	Air Cleaner Body (Incl.239,299 & 350)	1
72A	28483	Oil Drain Plug	1	243	650899	Screw, 10-32 x 2-3/32"	1
75	36010	Oil Seal	1	245	36046	Air Cleaner Filter	1
80	30574A	Governor Shaft	1	245A	36102	Air Cleaner Filter	1
81	30590A	Washer	1	250	36047	Air Cleaner Cover	1
82	30591	Governor Gear Ass'y. (Incl.81)	1	251	650928	Lock Nut 1/4-20	2
83	36057	Governor Spool	1	255	36110	Control Plate	1
85	36034	Idler Gear	1	256	650983	Screw, 8-32 x 17/32"	2

Table continued in next page

Tecumseh Engine model 143.99650

Table continued

Key No.	Part No.	Description	Qty.
260	36038	Blower Housing	1
261	650929	Screw, 1/4-20 x 11/16"	1
262	650737	Screw, 1/4-20 x 1/2"	3
263	36108	Trim Ring	1
275	36107	Muffler	1
276	36043	Locking Plate	1
277	650927	Screw, 5/16-18 x 2-11/32"	2
285	34449A	Starter Cup	1
287	650926	Screw, 8-32 x 21/64"	2
290	34357	Fuel Line	1
292	26460	Fuel Line Clamp	2
299	650900	"U" Type Nut Clip	1
300	36066	Fuel Tank (Incl. 301)	1
301	36246	Fuel Cap	1
305	36063	Oil Fill Tube	1
307	35499	O Ring	1
308	36040	Fill Tube Clip	1
310	36147	Dipstick	1
346A	28763	Screw, 10-32 x 35/64"	2
350	36045A	Primer	1
370A	36261	Lubrication Decal	1
370B	36530	Control Decal	1
370K	36695	Starter Decal	1
380	640020A	Carburetor	1
390	590737	Rewind Starter	1
		Note: This engine could have been built with 590694 starter.	
400	36062D	Gasket Set	1
		Note: Includes items 27234A, 28833, 36005A, 36032A, 36061, 37136, 696088.	
416	36085	Spark Arrestor Kit (Optional)	1
417	650760	Screw, 8-32 x 3/8" (Optional)	1
900	0	Replacement Engine none, order from 71-999	0
900	0	Replacement S/B 750850, order from 71-999	1

Tecumseh Engine model 143.99650

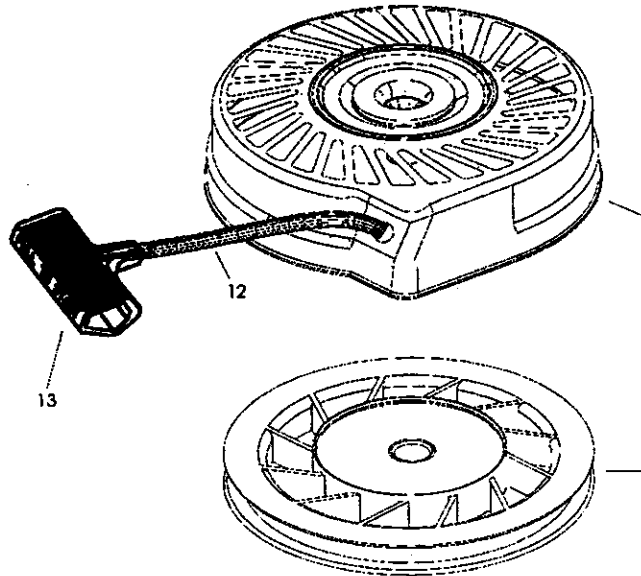
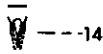

Key No.	Part No.	Description	Qty.
	590737	Rewind Starter	
3	590740	Retainer	1
6	590616	Starter Dog	2
7	590617	Dog Spring	2
8	590618A	Pulley & Rewind Spring Ass'y.	1
11	590687A	Starter Housing Assembly (40 degree grommet)	1
12	590535	Starter Rope (98" X 9/64" dia.)	1
13	590701	Starter Handle	1
14	590760	Spring Clip	1

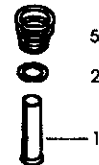
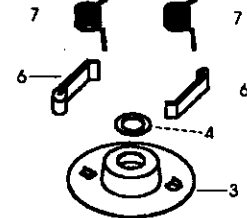
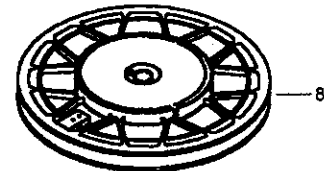
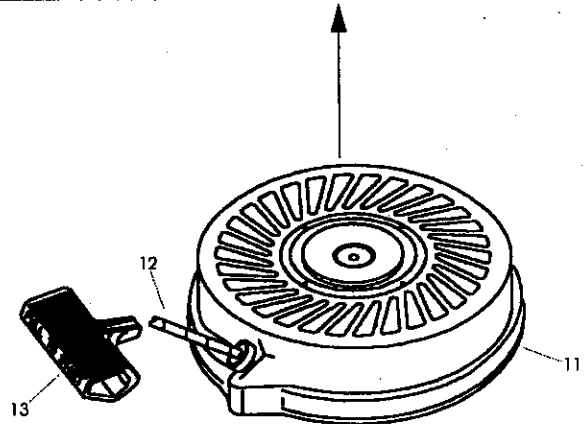
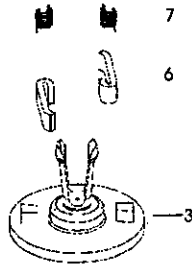

Key No.	Part No.	Description	Qty.
	590694	Recoil Starter	
1	590599A	Spring Pin (Incl. 4)	1
2	590600	Washer	1
3	590696	Retainer	1
4	590601	Washer	1
5	590697	Brake Spring	1
6	590698	Starter Dog	2
7	590699	Dog Spring	2
8	590700	Pulley & Rewind Spring Assembly	1
11	590695	Starter Housing Assembly	1
12	590535	Starter Rope (Length 98" x 9/64" dia.)	1
13	590701	Starter Handle	1

For in-home major brand repair service:

Call 24 hours a day, 7 days a week

1-800-4-MY-HOME (1-800-469-4663)

Para pedir servicio de reparación a domicilio — 1-800-676-5811

In Canada for all your service and parts needs call **1-800-665-4455**

Au Canada pour tout le service ou les pièces **1-800-665-4455**

For the repair or replacement parts you need:

Call 7 am - 7 pm, 7 days a week

1-800-366-PART (1-800-366-7278)

Para ordenar piezas con entrega a domicilio — 1-800-659-7084

For the location of a Sears Parts and Repair Center in your area:

Call 24 hours a day, 7 days a week

1-800-488-1222

**For information on purchasing a Sears Maintenance Agreement
or to inquire about an existing Agreement:**

Call 9 am - 5 pm, Monday - Saturday

1-800-827-6655



The Service Side of SearsSM