

RCA

camcorder user's guide

CC6151/CC6251/CC6271

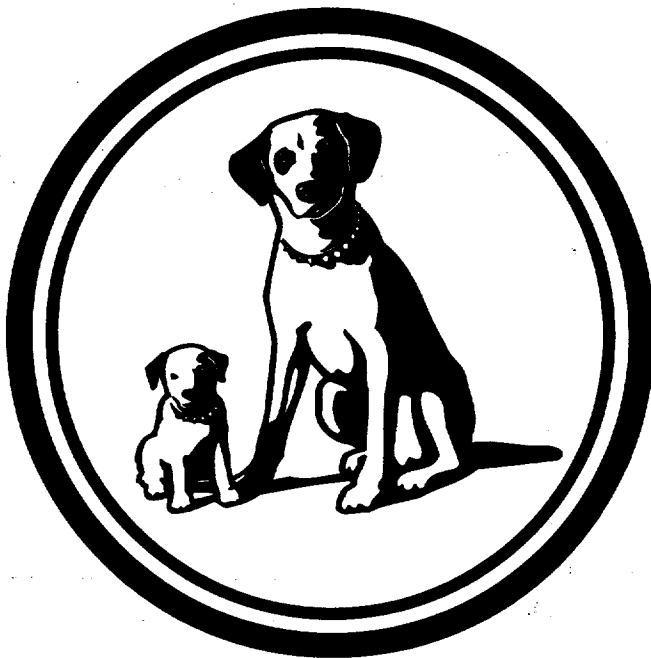

Important Safety Information

Be sure to read all the safety information before you begin to use this product.

WARNING: To reduce the risk of fire or shock hazard, do not expose camcorder or AC adapter/charger to rain or moisture.

CAUTION

RISK OF ELECTRIC SHOCK
DO NOT OPEN



This symbol indicates "dangerous voltage" inside the product that presents a risk of electric shock or personal injury.

ATTENTION

RISQUE DE CHOC ELECTRIQUE
NE PAS OUVRIR



This symbol indicates important instructions accompanying the product.

TO REDUCE THE RISK OF ELECTRIC SHOCK, DO NOT REMOVE THE COVER (OR BACK). NO USER-SERVICEABLE PARTS ARE INSIDE. REFER SERVICING TO QUALIFIED SERVICE PERSONNEL.

Cautions

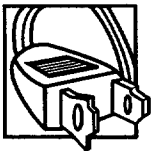

CAUTION: To prevent electric shock, match wide blade of plug to wide slot, fully insert.

ATTENTION: Pour éviter les chocs électriques, introduire la lame la plus large de la fiche dans la borne correspondante de la prise et pousser jusqu'au fond.

To reduce risk of injury, charge only rechargeable batteries recommended by the manufacturer for this camcorder. Other types of batteries may burst causing damage and personal injury.

FCC Regulations state that unauthorized changes or modifications to this equipment may void the user's authority to operate it.

Product Registration

Please fill out the product registration card and return it immediately. Returning this card allows us to contact you if needed.

Keep your sales receipt for proof of purchase to obtain warranty parts and service and attach it here. Record the serial number and model numbers located on the bottom of the camcorder.

Model No: CC6151 or CC6251 or CC6271

Serial No: _____

Purchase Date: _____

Purchased From: _____

Assistance

We want to make sure you enjoy your new camcorder. If you have any questions, call:

- Camcorder Exchange Warranty.....800-283-6503 (pages 84-85)**
- Customer Service.....800-336-1900 (page 83)**
- Accessories..... 800-338-0376 (pages 70-75)**

Table of Contents

Safety Information	i	Power Your Camcorder	
First Time Operation		• Use the Adapter/Charger to Power Your Camcorder	12
• Assistance	3	• Use the Battery to Power Your Camcorder	13-15
• Unpack the Camcorder and Accessories	3	• Use the Optional DCC08 Car Cord Adapter	16
• Attach the Adapter/Charger	4	Date and Time Display	
• Adjust the Handstrap to Fit Your Hand	4	• Install Clock Lithium Cell	17
• Slide <i>LENS COVER</i> Control to Open Lens Cover	4	• Set the Date and Time	18-19
• Insert a Tape	5	• Record the Date, Time, and Title Displays	20-21
• Set <i>POWER (CAMERA/OFF VCR)</i> Switch to <i>CAMERA</i>	5	Videocassettes	
• Adjust the Viewfinder and Eyepiece Focus Control	6	• Erase Protection	22
• Select a Recording Speed	6	• Recording and Playback Speeds and Times	22
• Select a Tape Length	7	• Insert and Remove Cassettes	23
• Set the <i>AE</i> Dial to <i>AUTO</i>	8	• Cassette Care and Storage	23
• Start and Stop Recording	8	Recording	
• Play Back What you Have Recorded	9	• Time-Remaining Display	24-25
• Set the <i>POWER</i> Switch to <i>OFF</i> to Turn Off the Camcorder	9	• Recording Tips	26
• Close the Lens Cover	9	• Use the Viewfinder to See What You Record	27
• Review Camcorder's Operating Controls	10-11	• Viewfinder Displays	28-31
		• Full Auto Mode	32

Table of Contents

• Quick Record Feature	33	Playback	
• Quick Review Feature	33	• Use the Viewfinder for Playback	60-61
• Tally Light	33	• Tracking	61
• Camera Edit Feature	33	• Playback Features	
• Flying Erase Head	33	• Position the Tape	62
• Auto Head Cleaner	33	• Visual Search	62
• Zooming		• Stop-Action Pause	62
• Use the Zoom Buttons	34-35	• Time Counter	63
• Tele Macro Zooming	35	• Memory-Stop Feature	63
• Focusing		• Use the Cassette Adapter	64-65
• Auto Focus	36	• Playback on TV (or VCR) with Audio/Video Inputs	66-67
• Manual Focus	36-37	• Playback on a TV Without Audio/Video Inputs	68-69
• White Balance	38-39	Optional Accessories	70-75
• Exposure Control	40-41	• Accessory Order Form	73-75
• Fade In and Out	42	Trouble Checks	76-79
• AE Dial	43	Care and Maintenance	
• Front Light and Back Light	44	• Clean the Camcorder	80
• Travel Tips	45	• Clean the Camcorder's Lens	80
• Titles		• Clean the Camcorder's Viewfinder	80
• Record a Preset Title or Title You Create	46	• Proper Care and Storage	81
• Create Your Own Title	47	• Things to Avoid	81
• Self-Timer Recording	48-49	Specifications	82
• Animation Recording	50-51	Information to User	82
• Time-Lapse Recording	52-53	Customer Assistance	83
• Tally Light (Turn On or Off)	54	Limited Warranty	84-85
• Demo Mode	55	Index	86-89
• JLIP (Joint Level Interface Protocol) Identification Number	56		
• Attach the Shoulder Strap	57		
• Model CC6271 Only: Built-In Color Enhancement Light	58-59		

First Time Operation

This section describes the steps necessary to set up your camcorder to record. Refer to the other sections for detailed operation and feature options.

Assistance

The toll-free numbers are available to help you with any problem you may encounter.

Camcorder Exchange Warranty.....800-283-6503

Customer Service..... 800-336-1900

Accessories..... 800-338-0376

1. Unpack the camcorder and accessories.

- Save the packing materials and box in case you ever need to ship or store your camcorder.
- The items shown below are packed with your camcorder. If any are missing or appear damaged, contact your dealer immediately.

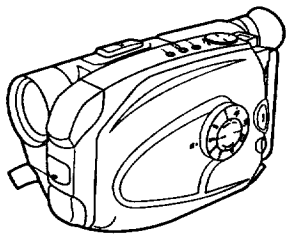

Model CC6151 or CC6251 or
CC6271 Camcorder*
(*Your camcorder may appear slightly
different than the one shown.)

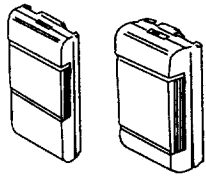

Rechargeable Battery
Part No FB1260
or BB700

**WARNING:
NICKEL
CADMIUM
BATTERY
MUST BE
RECYCLED
OR DISPOSED
OF PROPERLY.**



Shoulder Strap
Part No. ACS091

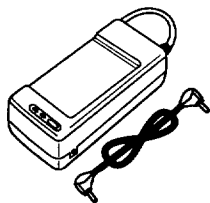

AC Adapter/Charger
and DC Cable

Caution: Do not use
this adapter/charger
for any purpose other
than charging the
FB1260, BB700, or
FB120 battery pack or
supplying power to
the camcorder.

Part No. 241017
Part No. 233087

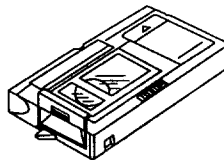

Cassette Adapter
Part No. VCA115A

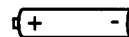

Cassette Adapter Battery
(Size "AA" 1.5 Volt)



Clock Cell

3-Volt Micro Lithium
Cell – such as CR2025 –
available from most local
drug stores and camera
shops. Use of other cells
present a risk of fire or
explosion.

CAUTIONS: Lithium cell must be disposed of properly. Never handle
punctured or leaking cell. May cause burns or personal injury.

Keep out of the hands of children. Can cause death or injury if swallowed.
If swallowed, consult a physician immediately for emergency treatment.

The lithium cell used in this device may explode resulting in a fire or
chemical burn if mistreated. Do not recharge, disassemble, heat above
212°F (100°C), or incinerate.

Never use metallic tweezers to hold the cell, and never short circuit the +
and – sides of the cell.

(continued on next page)

First Time Operation

2. Attach the adapter/charger.

To AC 100-240,
50/60 Hz

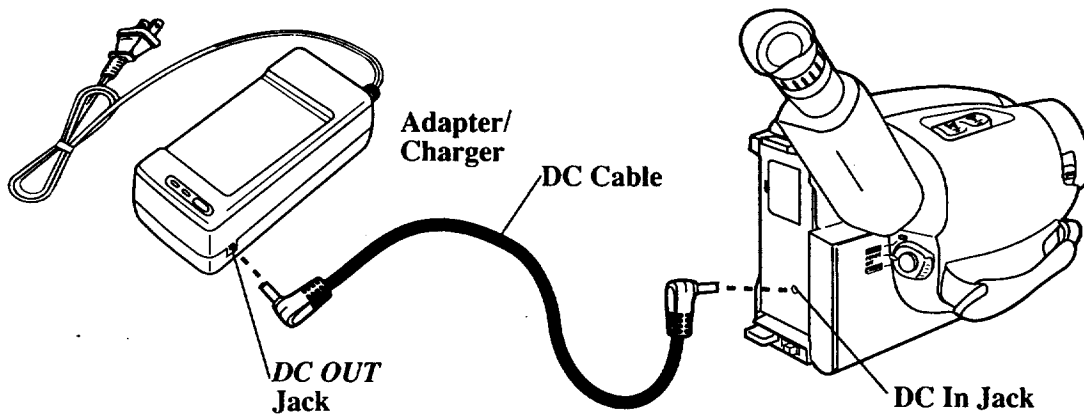

Since the battery must be charged before it can be used the first time, attach the adapter/charger to the camcorder.

- Connect one end of the DC cable to the *DC OUT* jack on the adapter/charger.
- Connect the other end of the DC cable to the DC in jack on the camcorder *as shown above*.
- Plug the adapter/charger's plug into an operating outlet.

3. Adjust the handstrap to fit your hand. ---

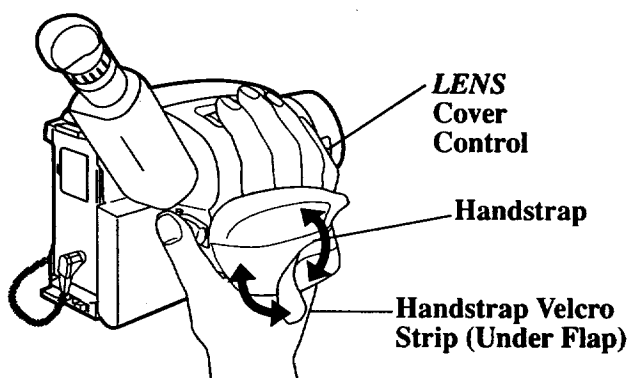

- Lift the flap on the handstrap and separate the velcro strip.
- Insert your hand, adjust the strap to fit snugly, refasten the strap, and close the flap.

4. Slide *LENS COVER* control to open lens cover. ---

First Time Operation

5. Insert a tape.

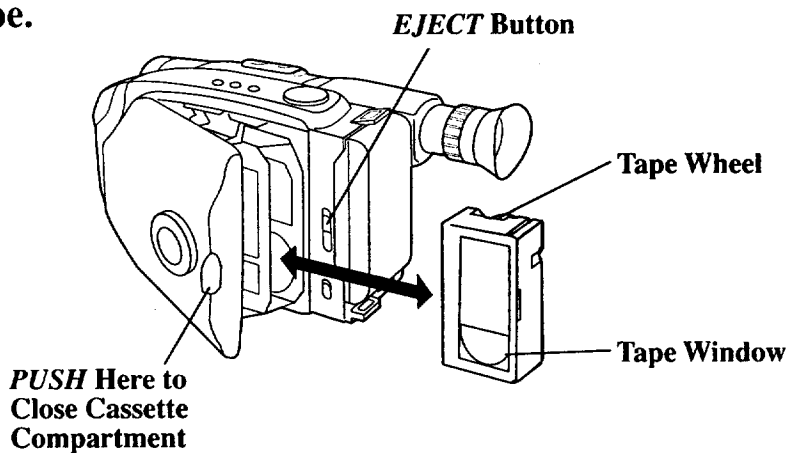

- Slide the *EJECT* button up. The cassette holder opens automatically.
- Turn the tape wheel on the cassette to remove any slack from the tape.
- Insert the cassette with the tape wheel facing up and the tape window facing out.
- Press on the area labeled *PUSH* until the cassette holder locks into place.

6. Set *POWER (CAMERA/OFF/VCR)* switch to *CAMERA*.

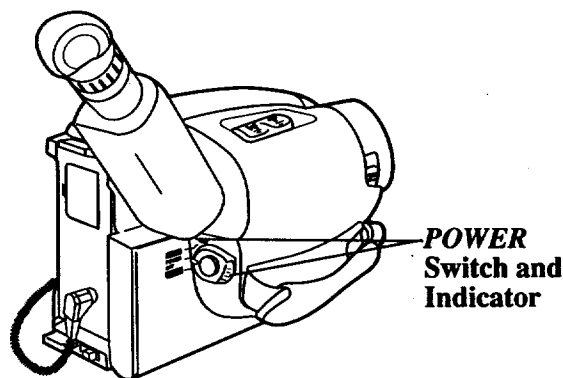

- The power indicator lights and the camcorder enters record-pause. **≡ PAUSE ≡** appears in the viewfinder when the camcorder is in record-pause.
- The position of this switch tells the camcorder whether you want to record (*CAMERA*), turn the power off (*OFF*), or play back tapes (*VCR*).
- The camcorder automatically turns off if it remains in record-pause for five minutes. Set *POWER* switch to *OFF* and then back to *CAMERA*.

(continued on next page)

First Time Operation

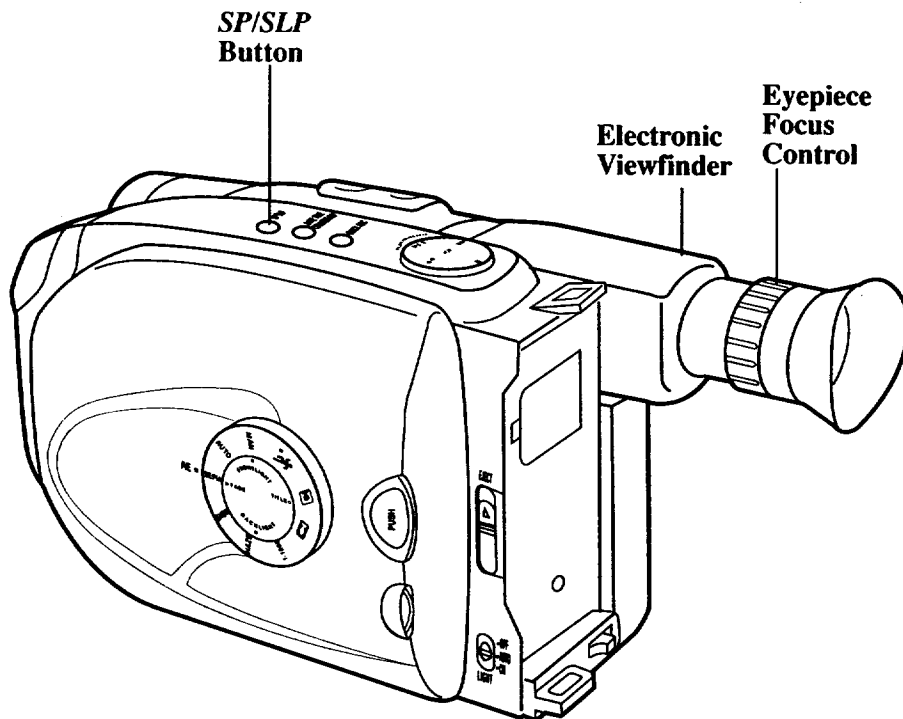

7. Adjust the viewfinder and eyepiece focus control.

You can see what you record in the viewfinder.

- Adjust the viewfinder for a comfortable viewing position.
- Turn the eyepiece focus control to adjust the focus of the viewfinder for your vision.

8. Select a recording speed.

Select SP or SLP recording speed. Press and hold the *SP/SLP* button to select a recording speed. The tape speed you select (*SP* or *SLP*) appears in the viewfinder.

- *SP* – Standard play provides the best picture, but the shortest recording time (20 minutes with a TC-20 tape).
- *SLP* – Extended play provides three times the recording time as *SP* (60 minutes with a TC-20 tape). *SLP* has slightly more picture noise in normal playback.

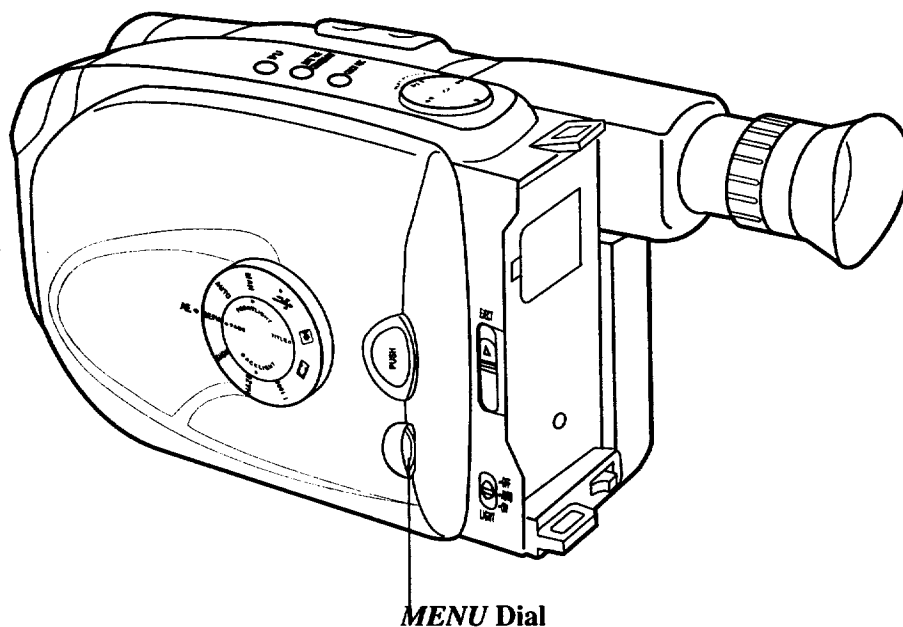

9. Select a tape length.

Set the length of the tape you are using so the camcorder can correctly calculate the recording time remaining on the tape.

- Place the *AE* dial in *MAN*, and press the *MENU* dial to display the *MENU* in the viewfinder. Rotate the dial to select *TAPE LENGTH*.
- Press the *MENU* dial in to display the *TAPE LENGTH* menu. Rotate the dial to select the length of tape you are using (*T20*, *T30*, or *T40*).
- Select *T20* for a tape with 20 minutes or less recording time in *SP*.
- Select *T30* for a tape with 30 minutes recording time in *SP*.
- Select *T40* for a tape with 40 minutes recording time in *SP*.
- Press the *MENU* dial **twice** to remove the menus from the viewfinder.
- *Details are on pages 24-25.*

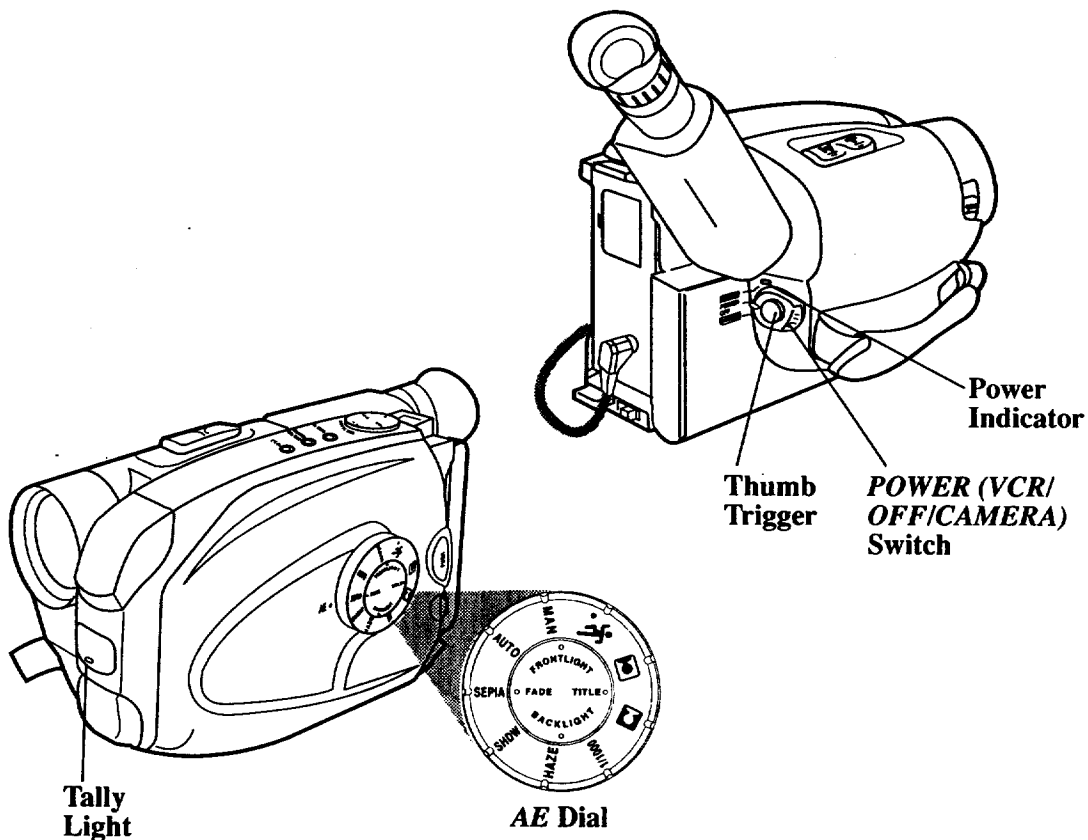

10. Set the AE dial to AUTO.

- This places the camcorder in the *AUTO* mode.
- In the *AUTO* mode, the focus, exposure, and white balance are automatically controlled by the camcorder.
- Many of the special effects do not operate in the *AUTO* mode.
- *Details on page 32.*

11. Start and stop recording.

- Press and release the thumb trigger to start recording. **REC** appears in the viewfinder, and the tally light lights while the camcorder is recording.
- Press and release the thumb trigger again to stop recording. The camcorder is now in the record-pause mode. **≡ PAUSE ≡** appears in the viewfinder.

(continued on next page)

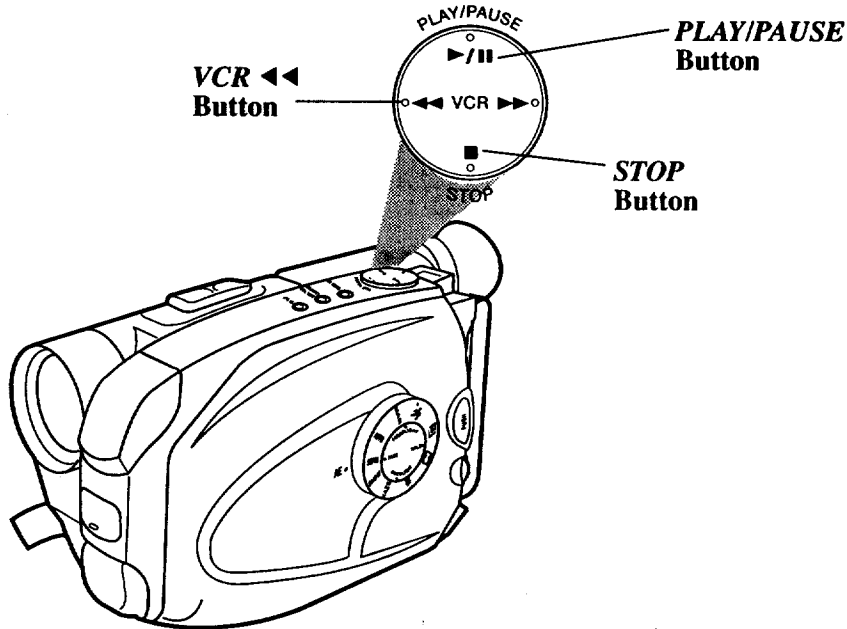

12. Play back what you have recorded.

- Set the *POWER* switch to *VCR*.
- Press *VCR* ◀◀ to rewind the tape.
- Press *PLAY/PAUSE* to play back the tape.
- Press *STOP* when you are finished playing back the tape.
- *Details on viewfinder playback are on pages 60-61.*

13. Set the *POWER* switch to *OFF* to turn off the camcorder.

The power indicator turns off.

14. Close the lens cover.

(continued on next page)

First Time Operation

15. Review camcorder's operating controls.

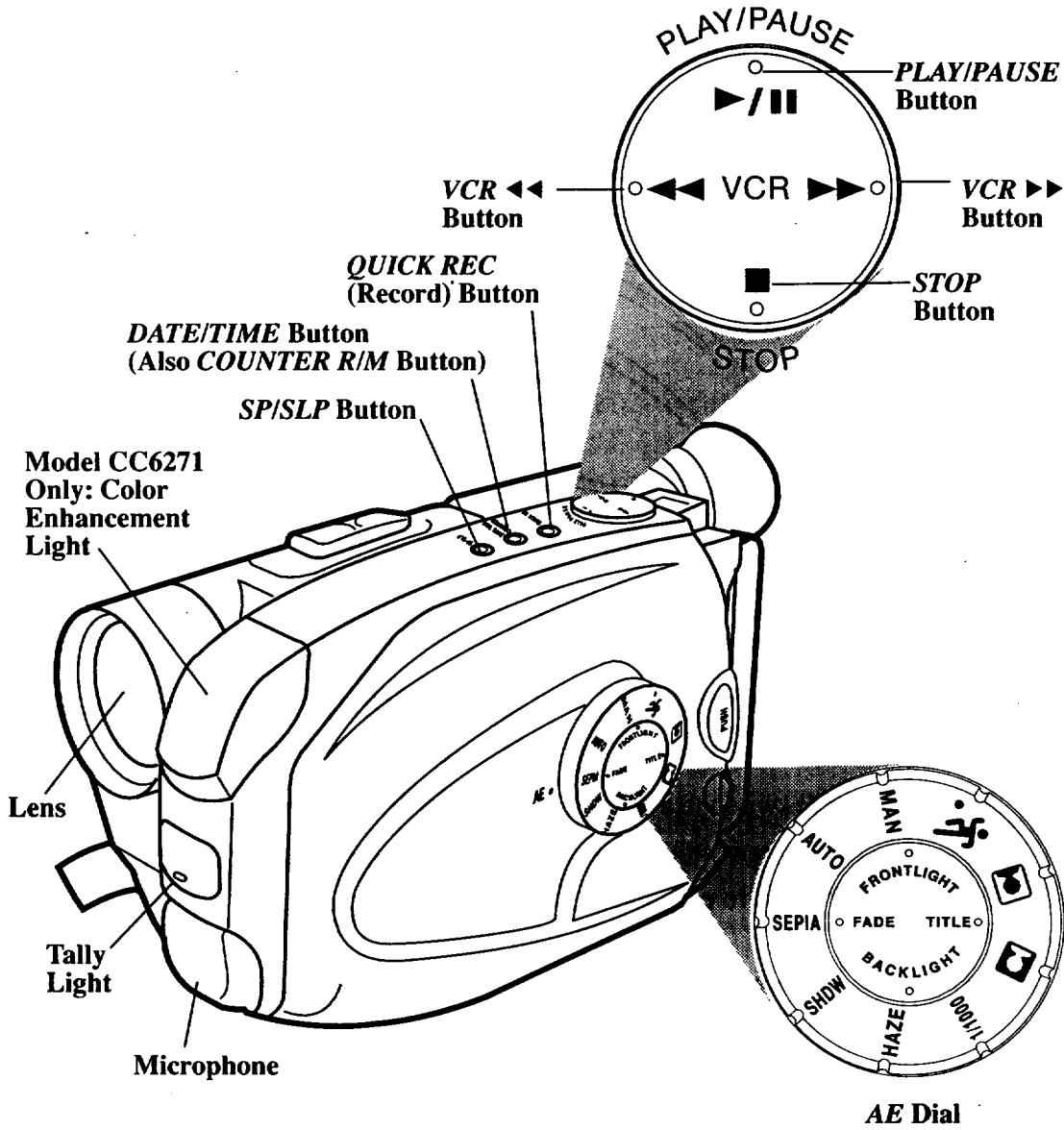

First-Time Operation

15. Review camcorder's operating controls. (continued)

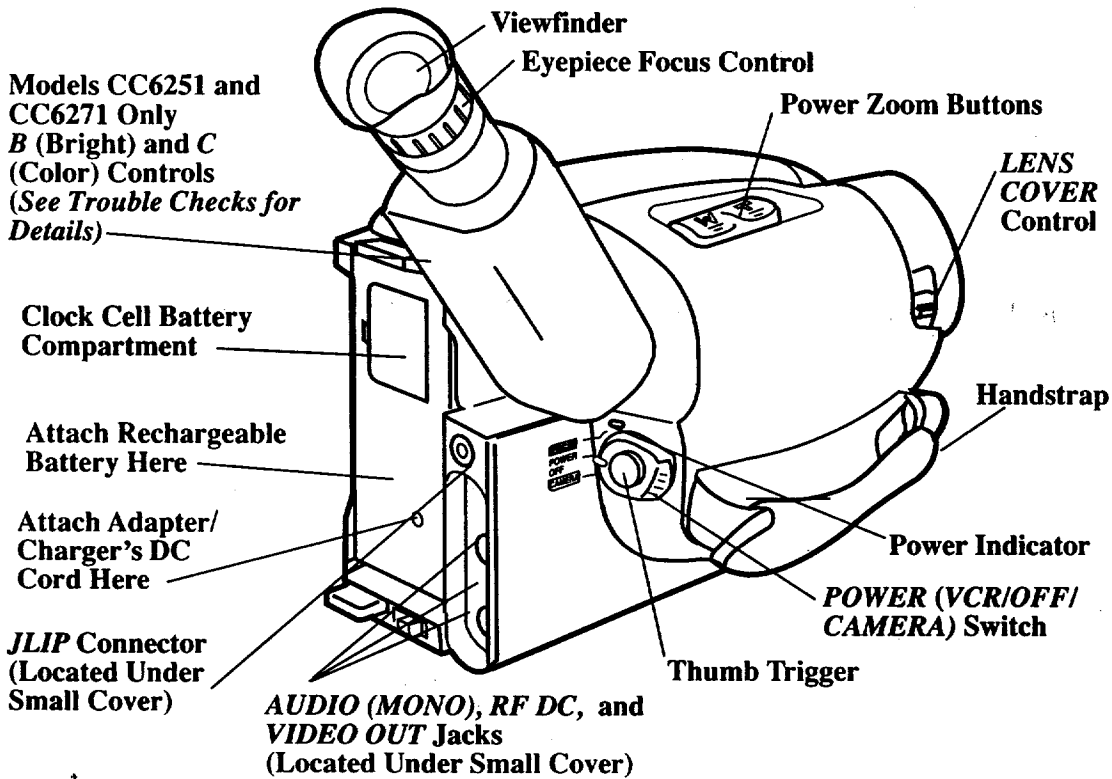
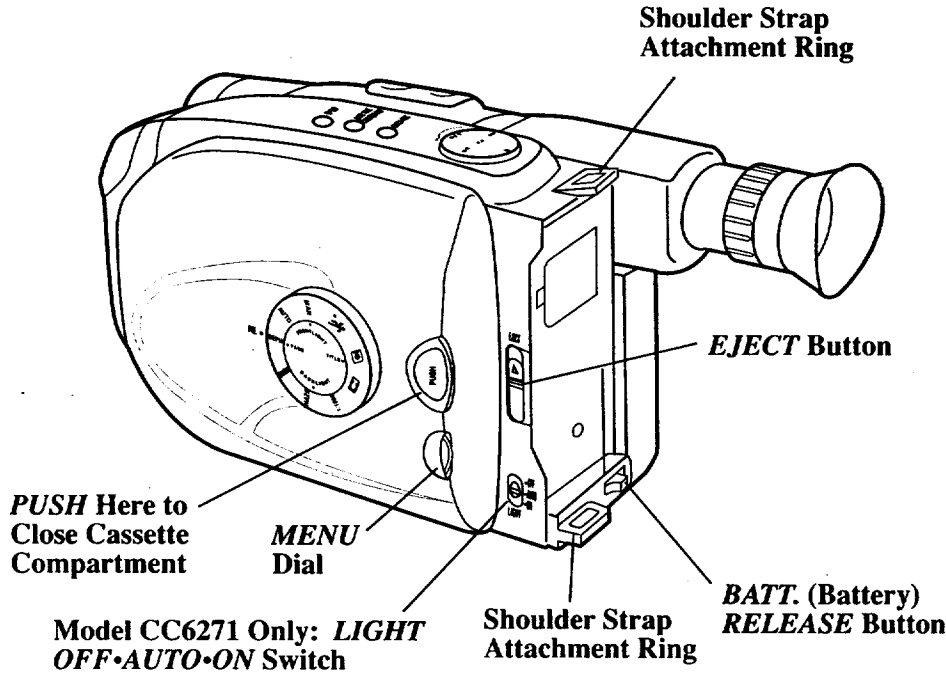

Power Your Camcorder

Use the Adapter/Charger to Power Your Camcorder

The adapter/charger attaches to the camcorder and lets you power your camcorder directly from standard household power. The adapter/charger operates on 100-240 volts, 50/60 Hz, so it can be used virtually anywhere in the world to power the camcorder or recharge the battery.

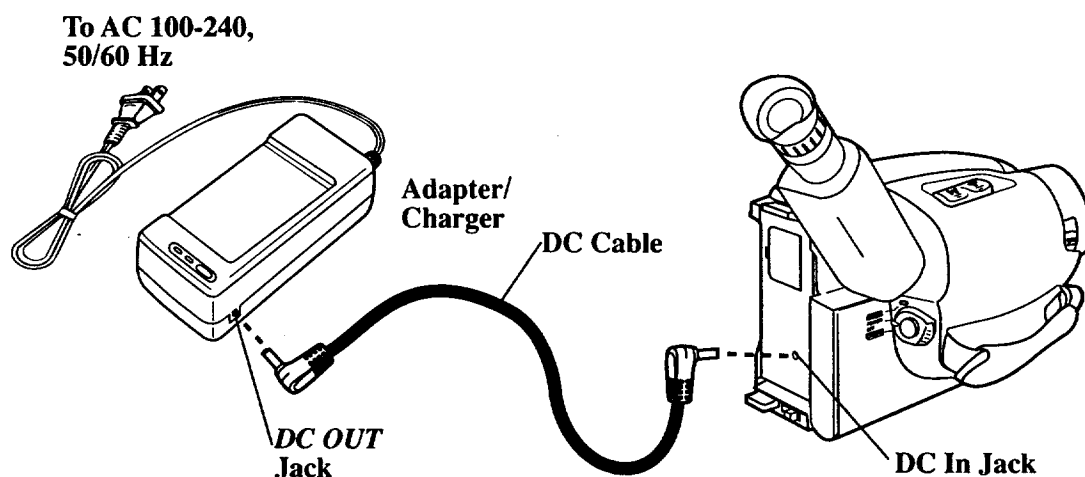

Attach Adapter/Charger

1. Connect one end of the DC cable to the *DC OUT* jack on the adapter/charger.
2. Connect the other end of the DC cable to the DC in jack on the camcorder as shown above.
3. Plug the adapter/charger's plug into the nearest AC outlet (100-240V, 50/60Hz).

Remove Adapter/Charger

1. Unplug the adapter/charger from the wall outlet.
2. Remove the DC cable from the adapter/charger and camcorder.

Using an Optional Plug Adapter

An optional plug adapter might be required in some countries.

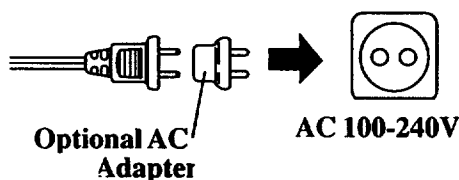

1. Plug the adapter/charger's plug into the AC plug adapter.
2. Plug the AC plug adapter into the AC outlet.

CAUTION: Do not use this adapter/charger for any other purpose other than charging the FB1260, BB700, or FB120 battery pack or supplying power to the camcorder.

Power Your Camcorder

Use the Battery to Power Your Camcorder

The battery must be charged *as described on the next page* before it can be used the first time. Initial charging takes approximately 70 minutes for the FB1260 (100 minutes for the BB700). When fully charged, the FB1260 supplies approximately 50-55 minutes (BB700 approximately 75-85 minutes) of operating time – depending on how much you use the light, zoom, and pause. Conserve battery power by turning the camcorder off during recording breaks.

Note: Use the small marker switch on the top of the battery to help remind yourself to charge the battery. It has no other purpose.

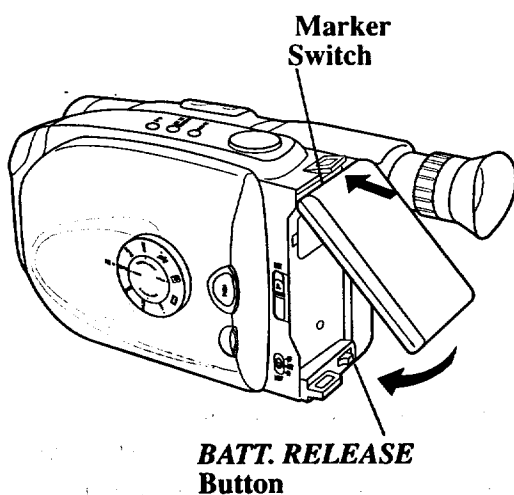

Battery Safety Precautions

Do not short the battery's terminals.

Do not attempt to disassemble or modify the battery. There are no user-serviceable parts inside.

Use the battery only with specified adapter/chargers and camcorders.

Throwing the battery into a fire or exposing it to excessive heat over 149° F (65° C) could be hazardous.

Attach the Charged Battery

If the DC cable is attached to the camcorder, remove it before attaching the battery. Also, install the lithium clock cell before attaching the battery.

Details are on page 17.

1. Hook the top end of the battery to the back of the camcorder *as shown above*.

2. Press the battery down until it locks into place.
3. Set the *POWER* switch to *CAMERA*. The power indicator lights.

Remove the Battery

Slide and hold the *BATT. RELEASE* button to the right while removing the battery.

ATTENTION: The RBRC seal on the battery used in your Thomson Consumer Electronics product indicates that we are participating in a program to collect and recycle Nickel Cadmium batteries throughout the United States. Please call 1-800-8-BATTERY for information or contact your local recycling center.



Use the Battery to Power Your Camcorder (continued)

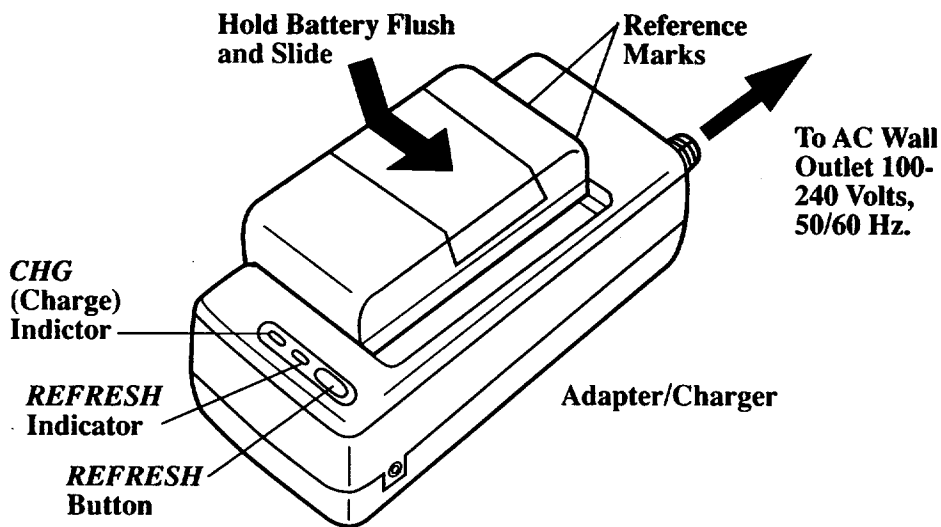

Caution: When a battery is attached to the adapter/charger, do not turn them upside down. The battery may fall off and be damaged or cause injury.

Charge the Battery

If the DC cable is attached to the *DC OUT* jack on the adapter/charger, remove it.

1. Align reference mark on battery with mark on adapter/charger.
2. Hold the battery flush against the adapter/charger and slide it in the direction of the arrow.
3. Plug adapter/charger into nearest AC outlet (100-240V, 50/60Hz).
4. If the battery is properly connected, the *CHG* indicator flashes.

Note: If you try to charge a battery that has not been charged for a long period of time, it may take a few minutes for the *CHG* indicator to flash.

5. After the battery is charged, the *CHG* indicator stops flashing and lights.
6. Remove the charged battery by sliding it off the adapter/charger.
7. Attach the charged battery to the camcorder.

Use the *REFRESH* Button

The battery provides increased operation time if you "refresh" it after five chargings. The refresh feature "refreshes" the battery by completely discharging it.

1. Attach battery to adapter/charger.
2. Press *REFRESH*. The *REFRESH* indicator lights and the battery begins discharging.
3. When discharging is completed, the *REFRESH* indicator turns off, and the *CHG* indicator flashes. The battery now charges.
4. After the battery is charged, the *CHG* (charge) indicator stops flashing and lights.
5. Remove the battery from the adapter/charger.

Use the Battery to Power Your Camcorder (continued)

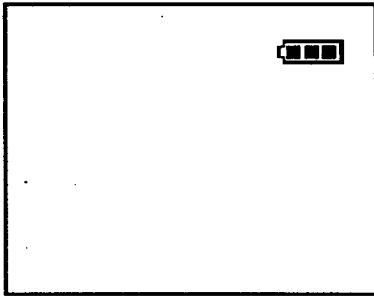

Battery Level Indicator

The battery level indicator appears in the viewfinder and shows you the amount of power in the rechargeable battery.



- When the battery power is almost gone,  flashes in the viewfinder. The camcorder turns off automatically after a few seconds. Set the *POWER* switch to *OFF* to turn off the camcorder before replacing the battery.

The battery level indicator is not recorded on the tape.

- When  appears, the battery is fully charged.
- As the power is used  and  appear.

Battery Care and Storage

- Recharging takes approximately 70 minutes for the FB1260 and 100 minutes for the BB700 depending on the battery's condition.
- Refreshing takes approximately 3-1/2 hours for the FB1260 and 5-1/2 hours for the BB700 depending on the battery's condition.
- After repeated charging and use, operation time gradually decreases. When operation time is too short to be useful, it is time to replace the battery.
- If the battery discharging must be stopped in the middle, remove the battery from the adapter/charger before unplugging it from the AC outlet.
- If the battery pack become too hot, remove it from the charger and let it cool down.
- Let a hot battery cool down before attaching it to the AC adapter/charger.

Power Your Camcorder

Optional Car Cord Adapter

The optional DCC08 car cord *shown on page 70* allows you to power your camcorder from the cigarette lighter socket of a car, truck, or RV. It converts 12-volts to a 6-volt output.

Note: Consult the installation and operating instructions enclosed with the DCC08 for complete operating instructions.

Cautions: The DCC08 is designed to be used only with vehicles having negative ground electrical systems.

Use only car cord adapter DCC08 with this camcorder. Use of any other car cord adapter might damage the camcorder and void your warranty.

Use the DCC08 Car Cord Adapter

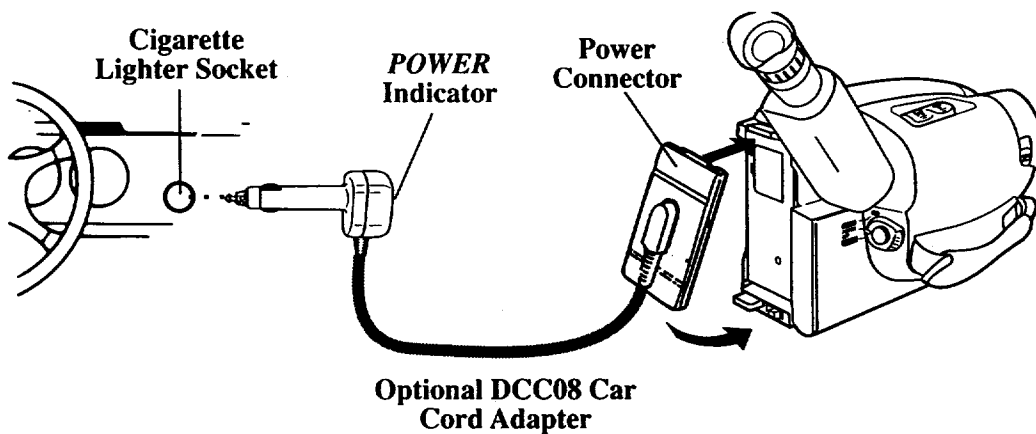

1. Set the *POWER* switch to *OFF* to turn off the camcorder. The power indicator on the camcorder turns off.
2. If the battery or DC cable is attached to the camcorder, remove it.
3. Hold the top of the power connector flush against the camcorder, and press the bottom of the power connector down until it locks into place.
4. Take the vehicle's cigarette lighter out of the socket.
5. Insert the car cord's cigarette lighter plug into the vehicle's cigarette lighter socket. The power indicator on the car cord adapter lights.
6. Set the *POWER* switch to *CAMERA* to turn on the camcorder. The power indicator on the camcorder lights.

Caution: Make sure the camcorder's power is turned OFF before removing the car cord's plug from the cigarette lighter socket.

Install the Clock Lithium Cell

The clock cell indicator  flashes for a few seconds in the viewfinder when you turn on the camcorder if the cell is not installed or needs replacing.

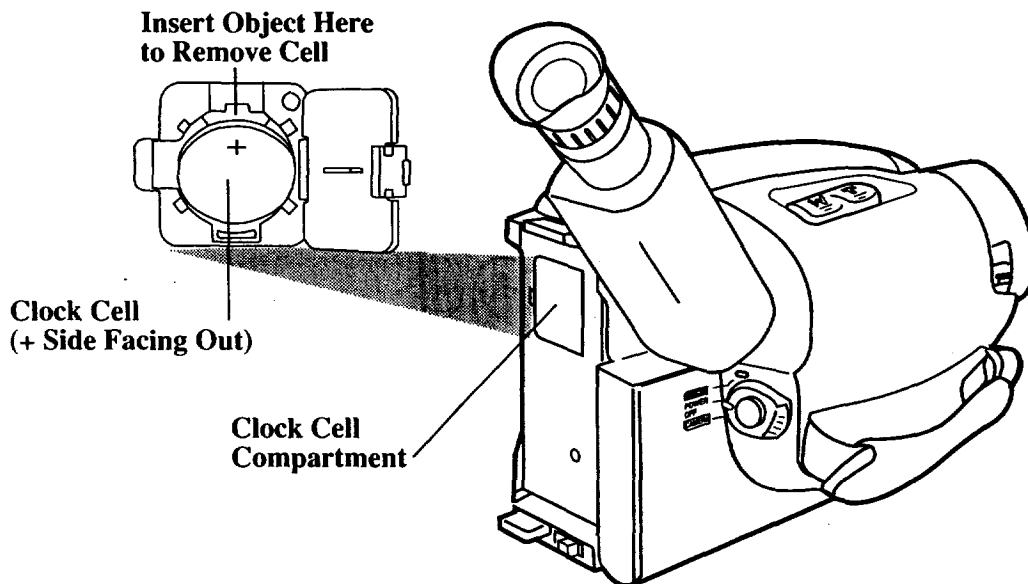

1. Make sure camcorder is turned off, and remove any power supply attached to the camcorder.
2. Press release tab of clock cell compartment cover and open the compartment.
3. Insert the clock cell with the "+" terminal facing out, and press it in.
4. Close the compartment cover. It clicks into place.

To Remove Lithium Cell

To remove battery, insert a pointed nonmetallic object between battery and compartment and lift.

Cautions: Lithium cell battery. Replace only with 3-volt lithium cell—such as CR2025. Use of other cell presents a risk of fire or explosion. Must be disposed of properly. Never handle punctured or leaking cell. May cause burns or personal injury.

Keep out of the hands of children. Can cause death or injury if swallowed. If swallowed, consult a physician immediately for emergency treatment.

The lithium cell used in this device may explode resulting in a fire or chemical burn if mistreated. Do not recharge, disassemble, heat above 212°F (100°C), or incinerate.

Never use metallic tweezers to hold the cell, and never short the + and - sides of the cell.

Date and Time Display

Set the Date and Time

You must set the correct date and time before you can display and record it on your tapes. The clock cell must be installed *as shown on the previous page* before you can set the date.

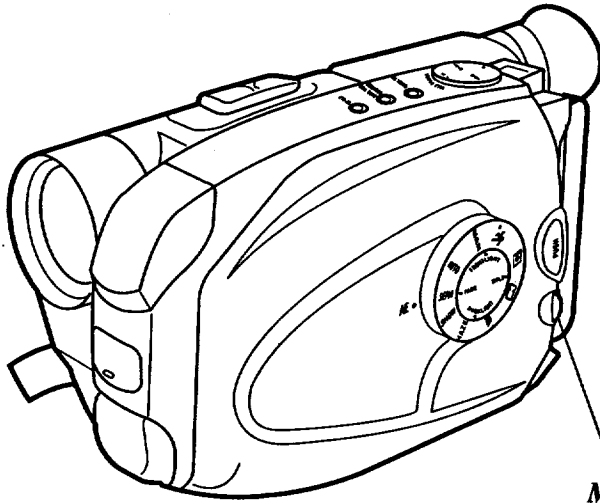

MENU Dial
(Rotate or Press In)

1. Set the *POWER* switch to *CAMERA*, and make sure the *AE* dial is not set to *AUTO*.
2. Press the *MENU* dial in to display the main *MENU* in the viewfinder.

MENU	
▶MENU END	
FOCUS	AUTO
EXPOSURE	AUTO
DATE/TIME	JAN 1.98
TELE MACRO	OFF
TAPE LENGTH	T30
M.W.B.	AUTO
ZOOM SPEED	FAST
▶NEXT	

MENU	
▶MENU END	
FOCUS	AUTO
EXPOSURE	AUTO
DATE/TIME	JAN 1.98
TELE MACRO	OFF
TAPE LENGTH	T30
M.W.B.	AUTO
ZOOM SPEED	FAST
▶NEXT	

3. Rotate the *MENU* dial to highlight *DATE/TIME*.

4. Press the *MENU* dial to display the *DATE/TIME* menu.

DATE/TIME	
YEAR	1998
MONTH	JAN
DAY	1
TIME	PM 12:00
EXIT	

5. Rotate the *MENU* dial to highlight *YEAR*. Press the *MENU* dial in.

Date and Time Display

Set the Date and Time (continued)

When *YEAR* starts flashing, rotate the *MENU* dial to select the year. When the correct year appears, press the *MENU* dial in to set the year.

- Repeat step 5 to set the *MONTH* and *DAY*.
- Rotate the *MENU* dial to highlight *TIME*.

DATE/TIME	
YEAR	1998
MONTH	NOV
DAY	18
TIME	PM 12:00
EXIT	

- Press the *MENU* dial in. When the hour starts flashing, rotate the *MENU* dial to set the hour including *AM* or *PM*.
- Press the *MENU* dial in. When the hour stops flashing and the minutes start flashing, rotate the *MENU* dial to set the minutes.
- Press the *MENU* dial in. When none of the settings are flashing, rotate the *MENU* dial to highlight *EXIT*.

DATE/TIME	
YEAR	1998
MONTH	NOV
DAY	18
TIME	AM 8:00
EXIT	

- Press the *MENU* dial in. The main *MENU* appears with *MENU END* highlighted.

MENU	
▶MENU/END	
FOCUS	AUTO
EXPOSURE	AUTO
DATE/TIME	NOV 18.98
TELE MACRO	OFF
TAPE LENGTH	T30
M.W.B.	AUTO
ZOOM SPEED	FAST
▶NEXT	

- Press the *MENU* dial in again to remove the main *MENU* from the viewfinder.

Notes:

If you decide to return the date and time to the previous settings while the *DATE/TIME* menu is displayed, rotate the *MENU* dial to highlight *EXIT*, and press. Press the *MENU* dial again to remove the main *MENU* from the viewfinder.

To display and record the date and/or time, see the following pages.

Date and Time Display

Record the Date, Time, and Title Displays

You must install the clock cell and set the date and time (*as shown on the previous pages*) before you can select and record the correct date and time. You must create your title (*as described on pages 46-47*) before you can select and record it.

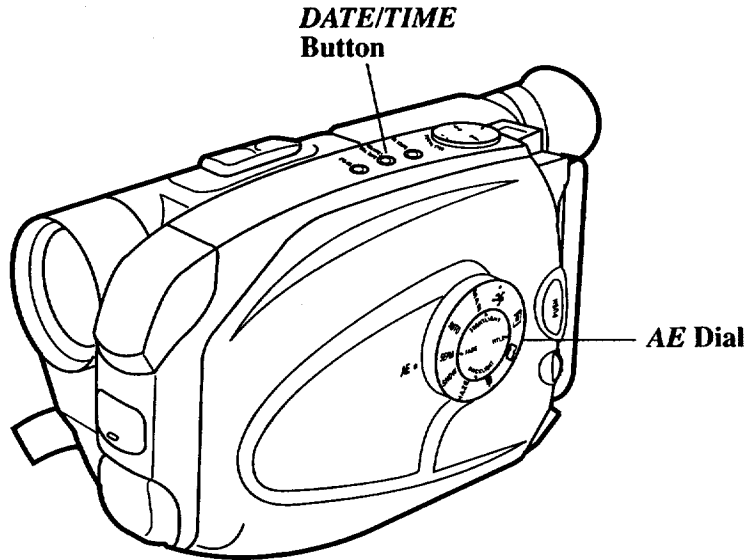

Select Date, Time, Date and Time, *AUTO DATE*, or Title You Created to Record On Your Tape

1. Attach a power supply and set *POWER* switch to *CAMERA*. The power indicator lights.
2. Make sure the *AE* dial is not set to *AUTO* to select any mode except *AUTO DATE*.
Note: *AUTO DATE* is selected when the *AE* dial is set to *AUTO*.
3. Repeatedly press the *DATE/TIME* button until the display you want to record appears in the viewfinder.
4. Select date, time, date and time, *AUTO DATE*, or the title you created.
 - **Date Display:** The date is displayed and recorded.
 - **Time:** The time is displayed and recorded.
 - **Date and Time Display:** The date and time are displayed and recorded.
 - ***AUTO DATE*:** The date is automatically recorded for approximately five seconds and then *AUTO DATE* is displayed whenever:
 - The date has been set or changed.
 - This display mode has just been selected.
 - The tape has been changed or the tape compartment opened.
 - **Title:** The title you have created is displayed and recorded. No display appears if a title has not been created.
 - **No Display:** No display is displayed or recorded.

Date and Time Display

Record the Date, Time, and Title Displays (continued)

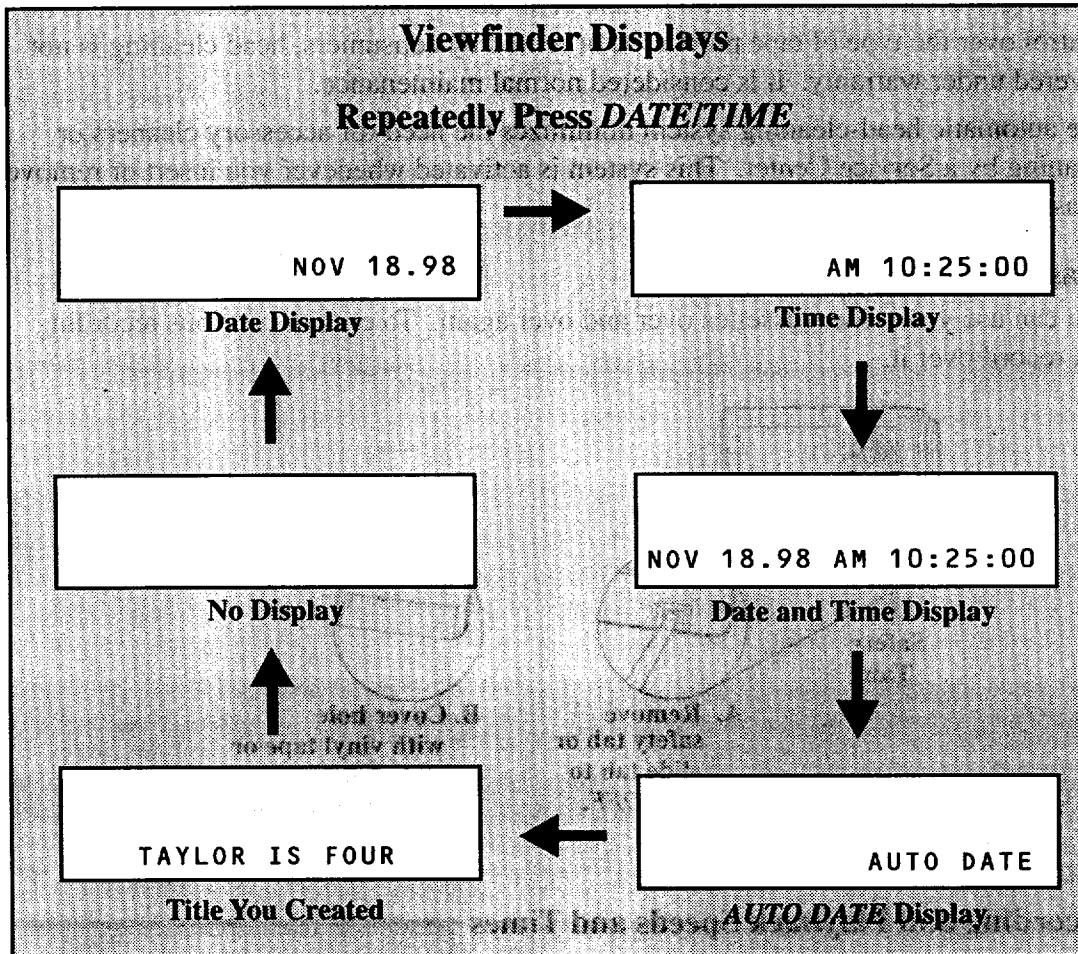

To Record the Date, Time, Date and Time, *AUTO DATE*, or Title You Created

1. Make sure the camcorder is in record-pause.
2. Make sure the *AE* dial is not set to *AUTO* unless you want to record *AUTO DATE*.
3. Repeatedly press *DATE/TIME* to display the date, time, date and time, *AUTO DATE*, or title you created.
4. Begin recording.
5. To remove the display, press *DATE/TIME* until no display appears in the viewfinder.

Note: If you do not want to record a date or time, press *DATE/TIME* to select the date and time off mode before you begin recording. No display appears in the viewfinder.

Videocassettes

Make sure you select good quality tapes for your camcorder. Use of poor quality tapes or tapes that have been damaged or mishandled can contaminate the video heads, resulting in a snowy picture or no picture at all during playback. Because there is no control over the type of tape purchased or rented by consumers, head cleaning is not covered under warranty. It is considered normal maintenance.

The automatic head-cleaning system minimizes the need for accessory cleaners or cleaning by a Service Center. This system is activated whenever you insert or remove a cassette.

Erase Protection – Safety Tab

You can use your videocassettes over and over again. To erase a previous recording, just record over it.

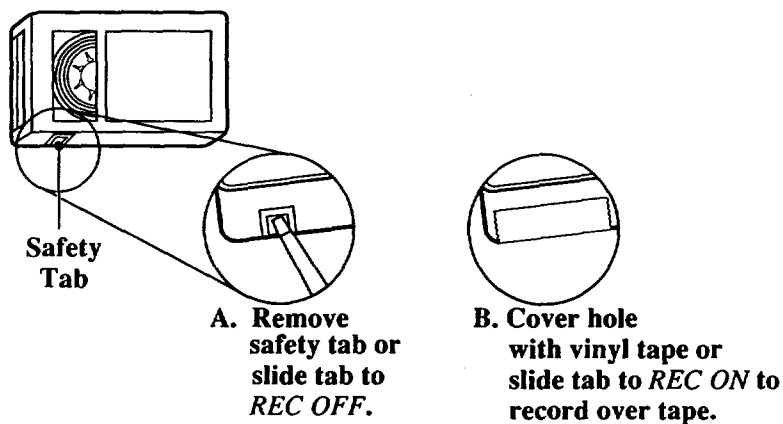

Recording and Playback Speeds and Times

The camcorder records and plays back in standard speed (SP) or extended play (SLP). Select the recording speed by pressing and holding the *SP/SLP* button. The selected speed is displayed in the viewfinder. Listed below are the maximum SP and SLP recording times for popular VHS-C cassettes.

- SP – Standard play provides the best picture (less picture noise), but the shortest recording time (20 minutes with a TC-20 tape).
- SLP – Extended play provides three times the recording time as SP (60 minutes with a TC-20 tape). SLP has slightly more picture noise than SP in normal playback. This might not be noticeable.

Cassette	Recording Time	
	SP	SLP
TC-20	20 Min.	60 Min.
TC-30	30 Min.	90 Min.
TC-40	40 Min.	120 Min.

Insert and Remove Cassettes

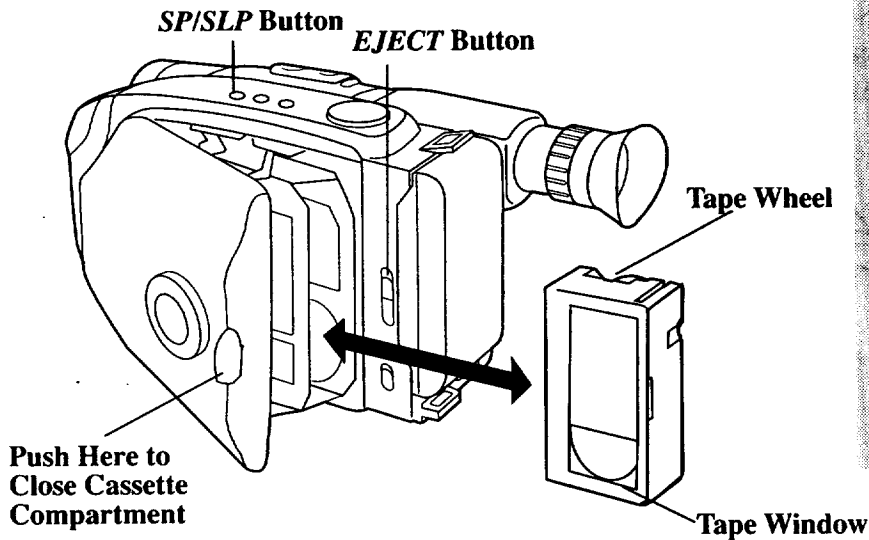

Caution: Insert the cassette only one way with the tape wheel facing up and the tape window facing out. The cassette should slide easily into the holder. Do not force the cassette.

Before inserting a cassette, turn the tape wheel on the side of the cassette in the direction shown to remove any slack in the tape.

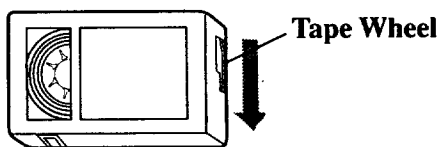

1. Press *EJECT*. The cassette holder opens automatically.
2. Insert the cassette with the tape wheel facing up and tape window facing out.
3. Press on the area labeled *PUSH* until the cassette holder locks into place.

Cassette Care and Storage

- When you are finished with a cassette, rewind it, remove it from the camcorder, and label it.
- Store cassettes vertically in their protective cases at normal room temperatures. Do not leave your camcorder or cassettes in a car or outdoors for an extended period. Excessive heat or cold might damage your cassettes.
- Keep the cassette away from strong magnetic fields such as electric motors and other devices.
- Keep dust from entering the cassette compartment. All dust is abrasive and causes excessive wear on the tape and the camcorder's recording or playback heads.
- Do not use cassettes with damaged or spliced tape.
- Do not use a cassette if it has been damaged or exposed to moisture. The tape might jam and/or damage your camcorder.

Time-Remaining Display

The approximate time remaining on the tape in the camcorder for the tape speed you select is displayed. You must set the correct tape length in the *TAPE LENGTH* feature of the main *MENU* before the camcorder can correctly calculate time remaining.

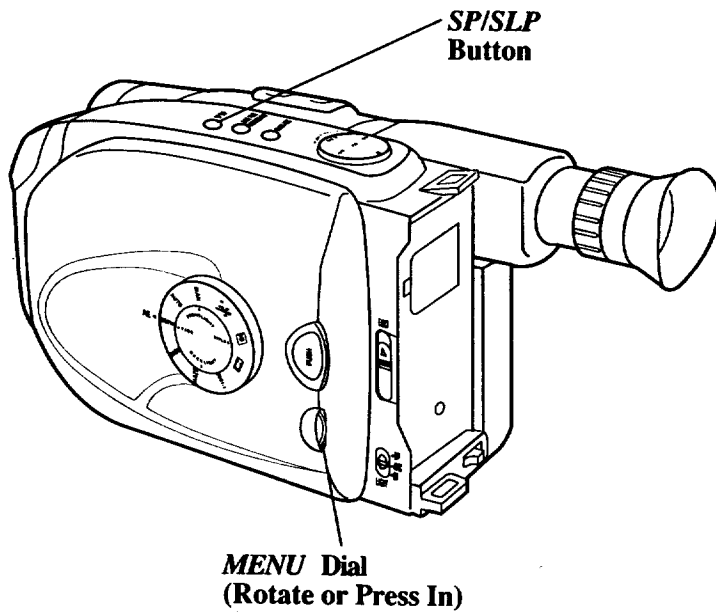

Select a Tape Length

1. Set the *POWER* switch to *CAMERA*, and make sure the *AE* dial is not set to *AUTO*.
2. Press the *SP/SLP* button to select a tape speed.
3. Press the *MENU* dial in to display the main *MENU* in the viewfinder.
4. Rotate the *MENU* dial to highlight *TAPE LENGTH*.

MENU	
▶MENU END	
FOCUS	AUTO
EXPOSURE	AUTO
DATE/TIME	NOV 18.98
TELE MACRO	OFF
TAPE LENGTH	T30
M.W.B.	AUTO
ZOOM SPEED	FAST
▶NEXT	

MENU	
▶MENU END	
FOCUS	AUTO
EXPOSURE	AUTO
DATE/TIME	NOV 18.98
TELE MACRO	OFF
TAPE LENGTH	T30
M.W.B.	AUTO
ZOOM SPEED	FAST
▶NEXT	

Recording

Time-Remaining Display (continued)

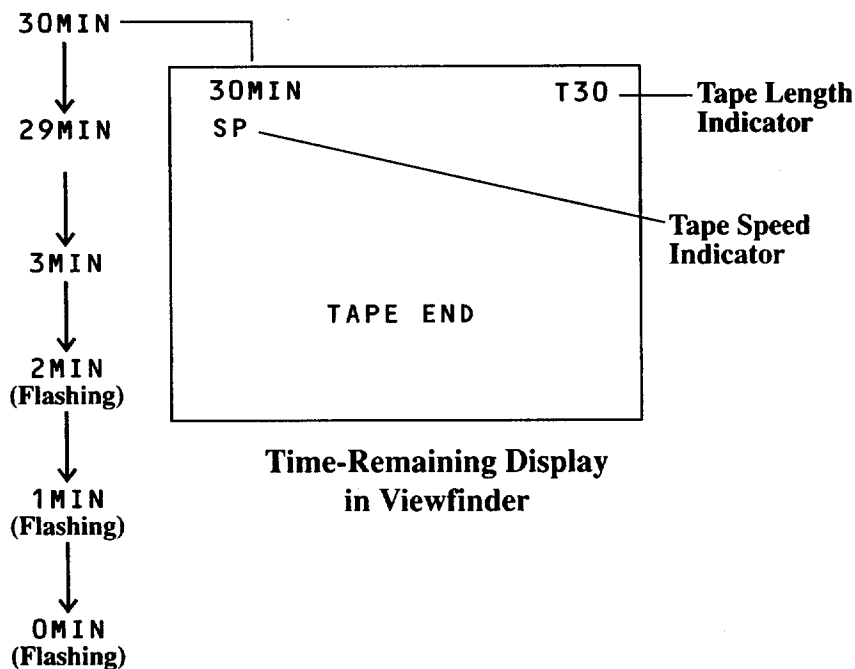

5. Press the *MENU* dial to display the *TAPE LENGTH* menu.

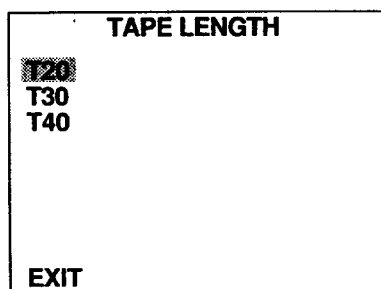

- Select *T30* for a tape with 30 minutes recording time in SP.
- Select *T40* for a tape with 40 minutes recording time in SP.

7. Press the *MENU* dial **twice** to select the speed and remove the *MENU*.

The time-remaining display starts flashing when the remaining tape time reaches two minutes.

TAPE END appears when the tape reaches its end during recording or a cassette is loaded that's tape is already at its end.

6. Rotate the *MENU* dial to highlight the type of tape you are using.
 - Select *T20* for a tape with 20 minutes or less recording time in SP.

Recording Tips

- Try to make sure indoor scenes are well-lit. This improves picture quality and color reproduction.
- Do not move the camcorder rapidly from side-to-side while recording. A steady, gradual “pan” avoids blurring and “jitter”.
- Use the viewfinder to make sure the camcorder is level while recording so that your scene isn’t “tilted”.
- Do not bump or tap the camcorder’s microphone while recording because this sound is recorded.
- Include close-ups of individuals when taping family outings or group functions.
- Fading in and out of scenes makes your videos appear more professional.
- Learn to use the special production effects available with your camcorder to add variety to your recordings.
- Be aware of video and audio backgrounds. Background details barely noticed while you are taping may show up as visual “clutter” on your recording. Background noises (especially TV sets, radios, household appliances, traffic sounds, etc.) might detract from the sound you want to record.
- Avoid long “still” shots of landmarks and scenic attractions. Recordings are more interesting if they include people and details. “Local color” gives travel videos lasting appeal. Consider recording a familiar or landmark scene from an unfamiliar vantage point.

Use the Viewfinder to See What You Record

The camcorder's viewfinder is a miniature monitor that displays the picture seen by the camcorder when recording.

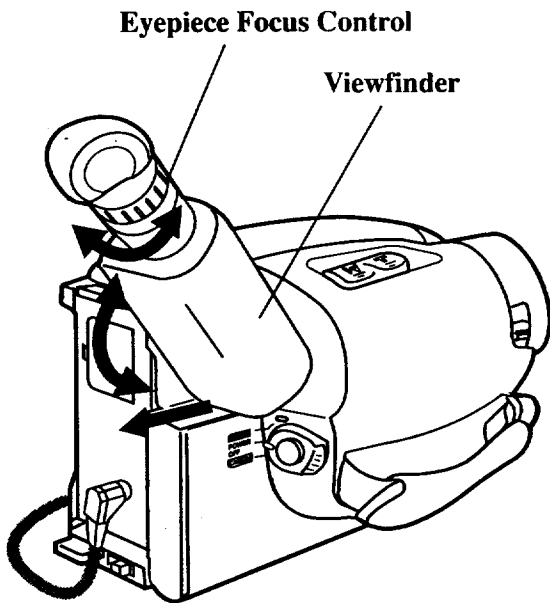

Cautions

Do not force the viewfinder to rotate completely around. This will damage the viewfinder and/or the camcorder.

When carrying the camcorder with the shoulder strap, put the viewfinder down and in to help prevent possible damage to the viewfinder from bumping against your body as you move.

Adjust Viewfinder for Convenient Viewing

For convenient viewing, slide the viewfinder out from the camcorder and rotate it up and down.

Eyepiece Focus Control

The eyepiece focus control lets you set the focus of the viewfinder for your vision. If you wear eyeglasses, you probably can operate the camcorder without them.

It is easiest to set the correct focus by focusing on one of the viewfinder's on-

screen displays. Look through the viewfinder and adjust the eyepiece focus control for your vision.

The eyepiece focus control does not affect the focus of the picture actually recorded by the camcorder.

Viewfinder Displays

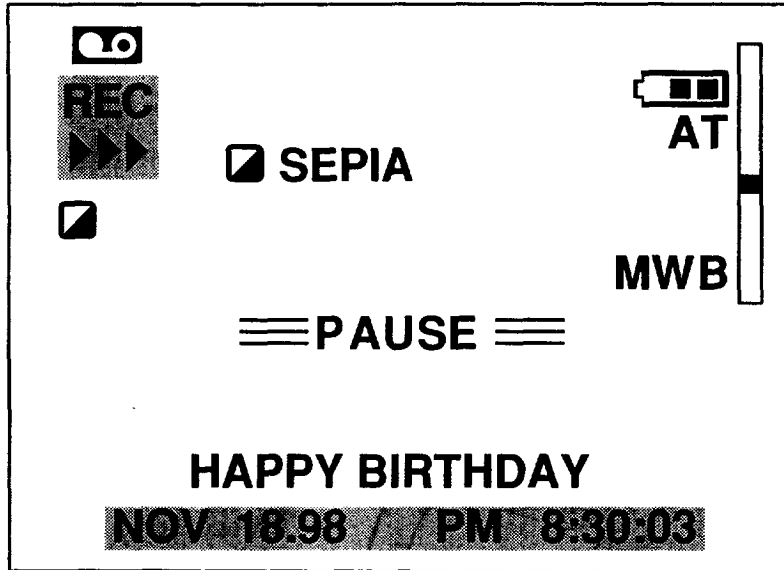
**AE Dial Special Effect Indicators**

- **AUTO** (Full Auto Mode)
AUTO LOCK appears briefly when you select *AUTO*.
- **MAN** (Manual Mode)
AUTO RELEASE appears briefly when you select *MAN*.
- **SPORTS**
This indicator appears when you select **SPORTS** to record fast-moving action, such as sporting events.
- **SEPIA**
This indicator appears when you select **SEPIA** to give your recordings a brown-tone like old photographs.
- **FRONT LIT**
This indicator appears when you select **FRONT LIT** to darken a subject that appears too bright because of front lighting.



- **BACK LIT**
This indicator appears when you select **BACK LIT** to make a subject appear brighter that appears too dark because of background lighting.
- **1 S 1/1000**
This indicator appears when you select **1/1000** to record fast-moving action.
- **HZ: HAZE**
This indicator appears when you select **HAZE** to soften the image and create a misty white look.
- **SD:SHADOW**
This indicator appears when you select **SHDW** to darken the picture and reduce glare.

Viewfinder Displays (continued)

Battery Level Indicator ()

- This indicator shows the amount of power left in the rechargeable battery.
- This indicator flashes when the battery is almost empty.

Cassette Warning

- The  indicator flashes when the **POWER** switch is set to **CAMERA** and there is no cassette in the camcorder.
- The  indicator flashes when the **POWER** switch is set to **CAMERA** and the safety tab is set to **REC OFF** or removed from the cassette.

Date, Time, Date and Time, **AUTO DATE**, or Title you Created

Press the **DATE/TIME** button to display the date, time, date and time, **AUTO DATE**, or the title you created.



- These displays are recorded when they are displayed. If you do not want to record one of them, press **DATE/TIME** until no display appears.
- *Details are on pages 20-21.*





Preset Titles

Press the **TITLE** button to display and record one of the eight preset titles or the title you created. *Details are on page 46.*







MWB (Manual White Balance Indicators)

The indicator for the manual white balance selected in the **MENU** appears here.

-  appears when you select  :**FINE** to record outdoors on a sunny day.

-  appears when you select  :**CLOUD** to record outdoors on a cloudy day.
-  appears when you select  :**HALOGEN** to record using halogen or tungsten lighting.
- **MWB** appears when you select **MWB** to adjust the color temperatures.
- *Details are on pages 38-39.*

Status Displays

- The  indicator appears when the camcorder is recording.
- The  **PAUSE**  indicator appears during record-pause.
-  appears when the camcorder plays back a tape.
-  appears during play-pause.
-  appears during fast forward.
-  appears during rewind.

(**AT**) Tracking Indicator

AT appears when the camcorder is adjusting tracking automatically.

Zoom Indicator ()

The zoom indicator appears here when you use the zoom lever.

Viewfinder Displays (continued)

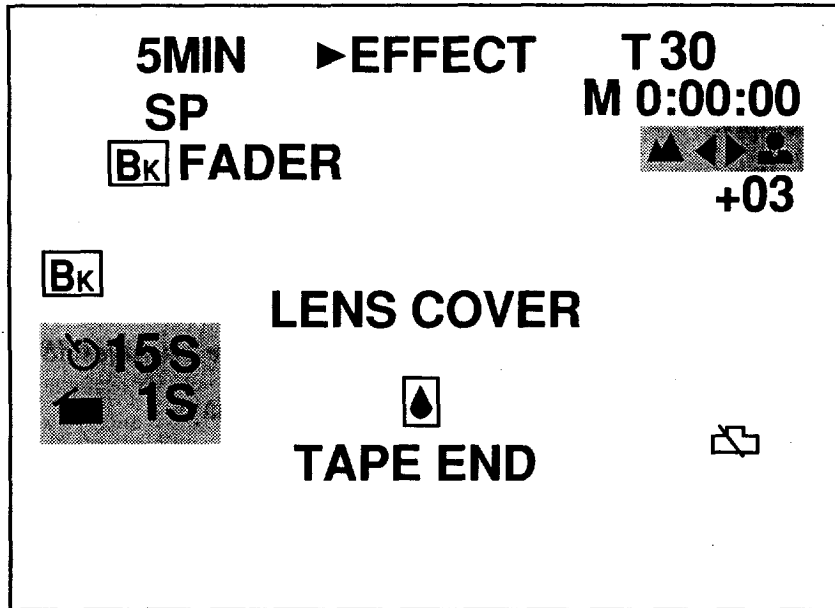

Dew Warning (💧)

The dew indicator appears when excessive moisture (condensation) has entered the camcorder. The camcorder will not operate when this indicator appears. Place the camcorder in a warm, dry area until this indicator disappears.

Exposure Indicators (+03)

This indicator appears when you are adjusting brightness manually using the *EXPOSURE* menu. Make sure the *AE* dial is not set to *AUTO*.

- Details are on pages 40-41.

Fade Indicators (▶EFFECT and Bk FADER)

The ▶EFFECT and Bk FADER indicators briefly appear when you press the *FADE* button to turn on fading. Bk remains when fading is turned on. Press *FADE* again to remove Bk and turn off fading.

Focus Indicators (▲◀▶●)

These indicators appear when you are adjusting focus manually using the *FOCUS* menu. Make sure the *AE* dial is not set to *AUTO*.

- The focus indicators (▲ ●) flash when the auto-focus system cannot operate properly.

Viewfinder Displays (continued)

- appear when you have selected *MAN* in the *FOCUS* menu.
- and flash while you adjust manual focus and and flash when you cannot adjust the focus any farther.
- *Details are on pages 36-37.*

Lithium Cell ()

- This indicator appears for a few seconds when you turn on the camcorder and the clock cell is missing or needs to be replaced.
- *Details are on page 17.*

Self-Timer, Animation, and Time-Lapse Indicators (*1S* and *15S*)

- The interval time selected for self-timer or time-lapse recording (*15S*, *30S*, *1MIN*, or *5MIN*) appears here. *Details are on pages 48-49 and 52-53.*
- The recording time selected for animation or time-lapse recording (*1/4S*, *1/2S*, *1S*, or *5S*) appears here.
- *Details are on pages 50-51 and 52-53.*

Tape Length (*T30*)

The tape length (*T20*, *T30*, or *T40*) selected in the main *MENU* appears here.

- *Details are on pages 24-25.*

Tape Speed Indicators (*SP* or *SLP*)

The tape speed selected with the *SP/SLP* button appears here.

- *Details are on pages 24-25.*

Time Counter (*M0:00:00*)

- The time counter appears during playback. It is not recorded.
- An “*M*” appears in front of the time counter when memory-stop is on.
- *Details are on page 63.*

Time-Remaining Display (*5MIN*)

The approximate time remaining on the tape is automatically displayed. The correct tape length must be set in the *TAPE LENGTH* feature of the main *MENU*.

- *Details are on pages 24-25.*

Warnings and Information

- *LENS COVER* briefly flashes to remind you to open the lens cover. *LENS COVER* might flash when the camcorder is used in dark areas -- even if the lens cover is open.
- *TAPE END* appears when the end of the tape is reached during recording or a cassette is inserted with its tape already at the end.

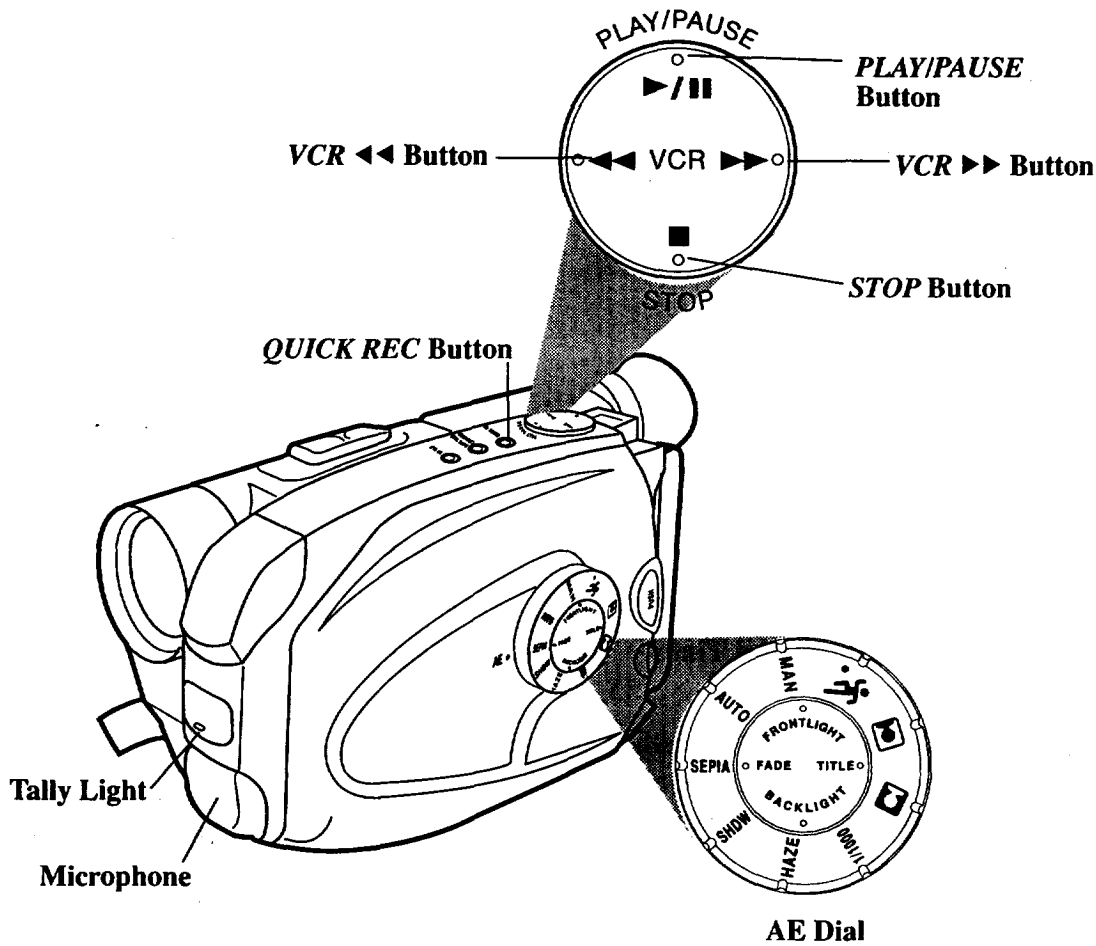

Full Auto Mode

The *AE* dial lets you select automatic or manual control of several features.

To Turn on the Full Auto Mode

1. Set the *POWER* switch to *CAMERA*.
The power indicator lights and the camcorder enters record-pause.
≡ PAUSE ≡ appears in the viewfinder.
2. Set the *AE* dial to *AUTO*.
3. Press the thumb trigger to start recording.

- The camcorder automatically controls focus, exposure, and white balance.
- The *MENU* dial will not operate.
- *AUTO DATE* is selected for the date and time display.

To Turn Off the Full Auto Mode

1. Set the *AE* dial to *MAN*.

Quick Record Feature

The quick record feature allows you to record for five seconds providing short scene transitions.

1. Set *POWER* switch to *CAMERA*.
2. Press *QUICK REC* to display 5S in the viewfinder.
3. Press the thumb trigger to start recording. The camcorder records for five seconds and enters record-pause.

To Turn Off the Quick Record Mode

1. Press the *QUICK REC* button to remove 5S from the viewfinder.

Quick Review Feature

Press and release *VCR* ◀◀ when the camcorder is in record-pause to review the last few seconds of a recording. The *POWER* switch must be set to *CAMERA*.

The camcorder plays back the last few seconds of the recording, returns the tape to its previous position, and returns to record-pause.

Tally Light

The tally light lights when the camcorder is recording. The tally light flashes during self-timer and time-lapse recording.

The tally light must be set to *ON* in the *TALLY LAMP* menu. See page 54 for details.

Camera Edit Feature

The camera edit feature allows you to position the tape when the camcorder is in record-pause. Set *POWER* switch to *CAMERA*.

- Press and hold *VCR* ◀◀ to visually search the recorded tape in reverse.
- Press and hold *VCR* ▶▶ to visually search forward on the recorded tape.

Release the button to return the camcorder to record-pause at that point on the tape. Press the thumb trigger to start recording at this point.

Flying Erase Head

A separate erase head is mounted on the spinning headwheel (hence the term “flying”). This allows you to make clean edits without the “glitches” or “rainbow noise” that might occur at the beginning or the end of recordings.

Auto Head Cleaner

The camcorder has an automatic head-cleaning system. Whenever you insert or remove a cassette, this system is activated.

The head-cleaning system minimizes the need for accessory cleaners or cleaning by a Service Center.

Recording

Zooming

You can zoom in and out for close ups or wide-angle shots just by pressing the zoom buttons on the camcorder. The camcorder automatically focuses when you zoom at most distances.

To record a close-up of a small subject closer than three feet. Turn on the *TELE MACRO* feature in the main *MENU*. You can record a small subject at a distance of approximately 23 inches.

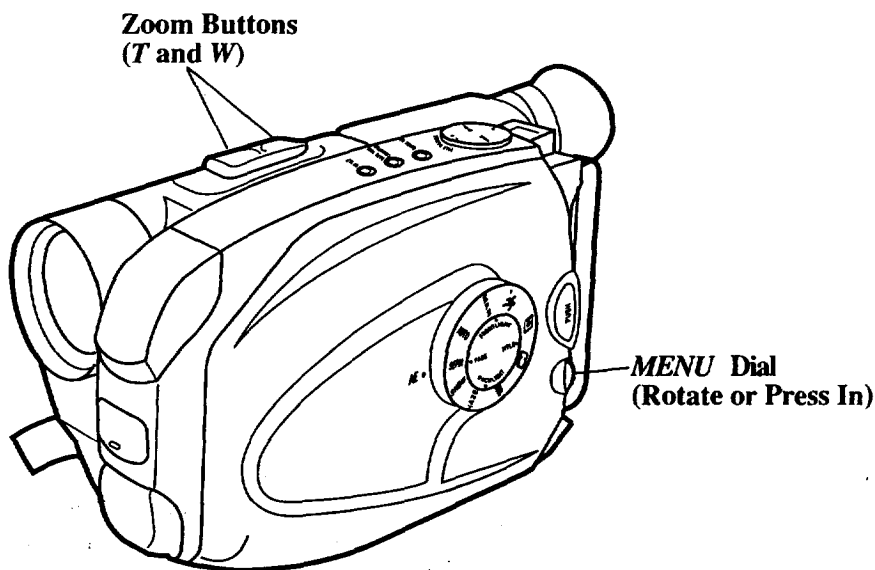

Use the Zoom Buttons (*W* and *T*)

- To zoom in or out, press one of the zoom buttons on the camcorder.
 - To move the lens in the telephoto (close-up) direction, press *T*.
 - To move the lens in the wide angle direction, press *W*.
 - The zoom level indicator appears in the viewfinder during zooming.

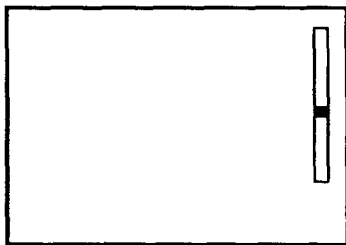

Use the *ZOOM SPEED* Menu

Select *ZOOM FAST* or *ZOOM SLOW* using the menus.

- Make sure the *POWER* switch is set to *CAMERA* and the *AE* dial is not set to *AUTO*.
- Press the *MENU* dial in to display the main *MENU*.

MENU	
▶MENU END	
FOCUS	AUTO
EXPOSURE	AUTO
DATE/TIME	NOV 18.98
TELE MACRO	OFF
TAPE LENGTH	T30
M.W.B.	AUTO
ZOOM SPEED	FAST
▶NEXT	

Zooming (continued)

3. Rotate the *MENU* dial to highlight *ZOOM SPEED*.
4. Press the *MENU* dial in to display the *ZOOM SPEED* menu.

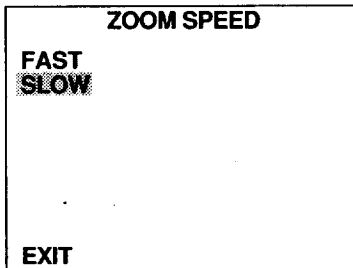

5. Rotate the *MENU* dial to highlight *FAST* or *SLOW*, and press the dial in.
 - Select *FAST* to zoom faster.
 - Select *SLOW* to zoom slower.
6. Rotate the *MENU* dial to *EXIT* and press the *MENU* dial in twice to remove the *MENU*.

Notes: For fastest zooming, select *FAST* in the *ZOOM SPEED* menu and press the zoom button firmly.

For slowest zooming, select *SLOW* in the *ZOOM SPEED* menu and press the zoom button lightly.

To Turn Tele Macro Zooming ON or OFF

1. Make sure the *POWER* switch is set to *CAMERA* and the *AE* dial is not set to *AUTO*.
2. Press the *MENU* dial in to display the main *MENU* in the viewfinder.

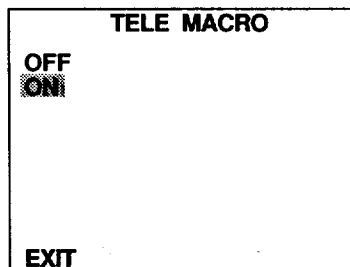
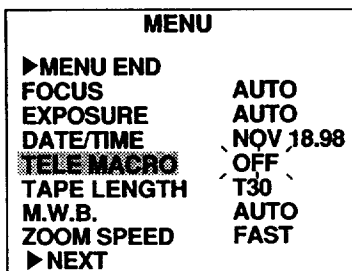

3. Rotate the *MENU* dial to highlight *TELE MACRO*.
4. Press the *MENU* dial in to display the *TELE MACRO* menu.
5. Rotate the *MENU* dial to highlight *ON* or *OFF* and press the dial in.
 - Select *ON* if you want to record a small subject within approximately 23 inches.
 - Select *OFF* for normal zooming.
6. Press the *MENU* dial twice to remove the *MENU*.

Focusing

The camcorder adjusts focus automatically under normal conditions. You might need to focus manually under certain conditions.

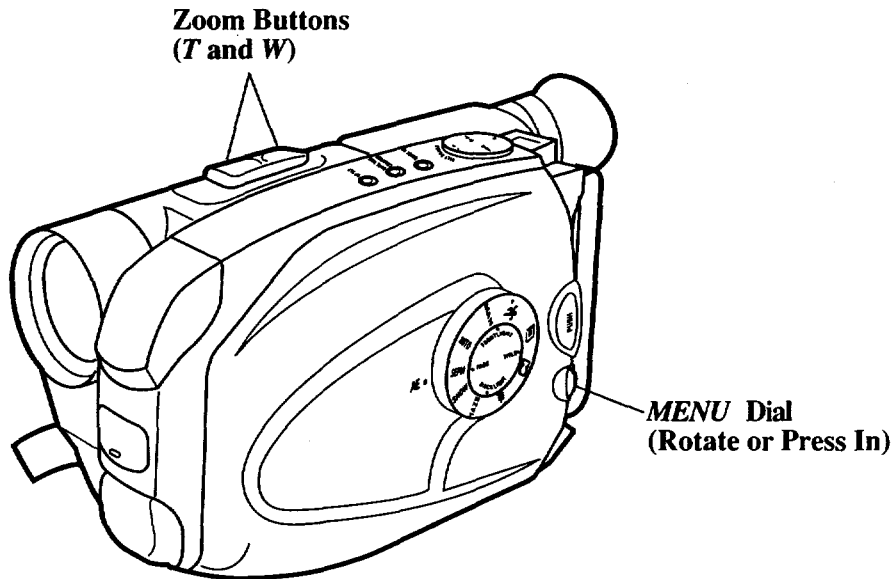

Auto Focus

During auto focus the camcorder focuses on the object located in the center area of the viewfinder.

- Set the *AE* dial to *AUTO* to turn on the auto focus feature. No focus indicator appears in the viewfinder.

Notes: The low-contrast indicator (▲ ●) in the viewfinder indicates the auto-focus system might not operate correctly due to low illumination, low or no contrast, repeated patterns, or two subjects at different distances overlapping.

Use tele macro zooming when recording a subject close to the lens or the camcorder may zoom out to focus.

The lens must be clean for the camcorder to focus accurately.

Manual Focus

You might need to focus manually under certain conditions.



1. Set the *POWER* switch to *CAMERA*, and make sure the *AE* dial is not set to *AUTO*.
2. Press zoom button *T* to zoom in on the subject and center the subject in the viewfinder.
3. Press the *MENU* dial in to display the main *MENU* in the viewfinder.

MENU	
▶MENU END	
FOCUS	AUTO
EXPOSURE	AUTO
DATE/TIME	NOV 18.98
TELE MACRO	OFF
TAPE LENGTH	T30
M.W.B.	AUTO
ZOOM SPEED	FAST
▶NEXT	

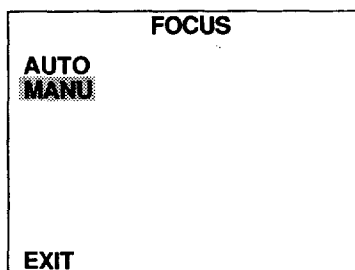

Focusing (continued)

4. Press the *MENU* dial in to display the *FOCUS* menu.



5. Rotate the *MENU* dial to highlight *MANU* (manual) and press the dial in.  appears in the viewfinder. The focus is locked at this point.
6. Adjust the focus for a subject nearer or farther away.
 - Rotate the *MENU* dial up to focus on a subject farther away. 

flashes while you are adjusting the focus and  flashes when you cannot adjust the focus any more.

- Rotate the *MENU* dial up to focus on a subject nearer.  flashes while you are adjusting the focus and  flashes when you cannot adjust the focus any more.

7. Press the *MENU* dial twice to remove the menus.

Notes: To return to auto focus, select *AUTO* in the *FOCUS* menu or set the *AE* dial to *AUTO*.

Conditions Requiring Manual Focus

- When recording a subject through a window.
- When recording a subject having a close foreground and a background that is far away.
- When recording in low-light situations.
- When recording two subjects at different distances that overlap in the same scene.
- When the subject is not in the center of the scene.
- When recording a scene with fast motions, like a tennis swing.

White Balance

Making colors look natural is what white balance is all about. This is achieved by adjusting the way the camcorder “sees” and records the light source in the scene you record. Your camcorder is equipped with automatic white balance.

You might want to adjust white balance manually under certain conditions, such as recording an object with various shades of the same color or when recording a predominantly red or brown object outdoors.

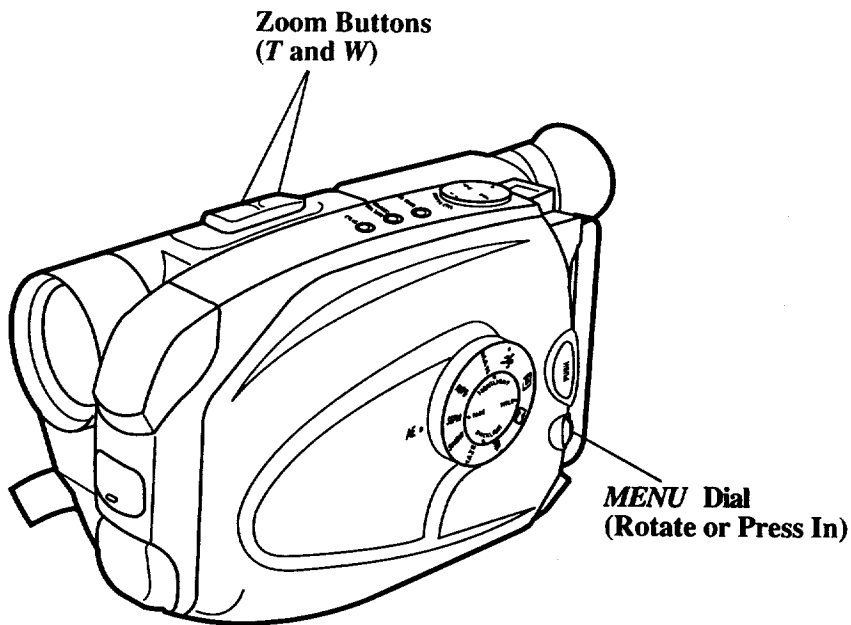

Auto White Balance

During auto white balance, the camcorder adjusts the white balance.

- Set the *AE* dial to *AUTO* to turn on the automatic white balance feature. No indicator appears in the viewfinder.

Manual White Balance

1. Set the *POWER* switch to *CAMERA*, and make sure the *AE* dial is not set to *AUTO*.
2. Press the *MENU* dial in to display the main *MENU* in the viewfinder.

MENU	
▶MENU END	
FOCUS	AUTO
EXPOSURE	AUTO
DATE/TIME	NOV 18.98
TELE MACRO	OFF
TAPE LENGTH	T30
WHITE BAL	AUTO
ZOOM SPEED	FAST
▶NEXT	

White Balance (continued)

3. Rotate the *MENU* dial to highlight *M.W.B.* and press the dial in to display the *M.W.B.* menu.

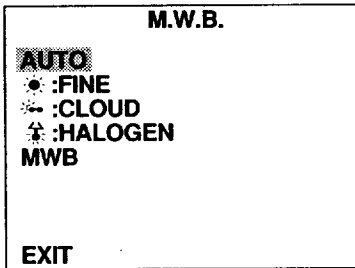

4. Rotate the *MENU* dial to highlight the white balance you want to use.
 - No indicator appears when you select *AUTO* white balance.
 - Select *FINE* when recording outdoors on a sunny day.
 - Select *CLOUD* when recording outdoors on a cloudy day.
 - Select *HALOGEN* when recording using halogen or tungsten lighting.
 - Select *MWB* when shooting subjects with different color temperatures and adjust the white balance as follows:

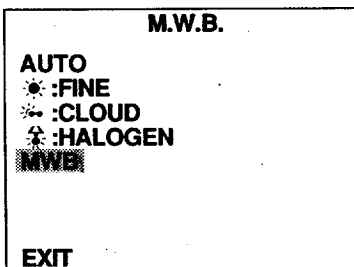

Note: Connecting your camcorder to a color TV monitor may be helpful when making white balance adjustments.

- A. Point camcorder at a white, flat object such as a piece of white paper.
- B. While *MWB* is highlighted, press and hold the *MENU* dial until *MWB* starts flashing.
The *MWB* indicator flashes while the camcorder is adjusting white balance and stops flashing when it is ready to record.

Note: To change the tint for special recording, substitute colored paper for white. The white balance is adjusted based on the color.

Red paper – deeper green

Blue paper – orange

Yellow paper – deeper purple

5. Press the *MENU* dial **twice** to select a white balance and remove the menus.

Notes: To return to auto white balance, select *AUTO* in the *M.W.B.* menu or set the *AE* dial to *AUTO*.

Exposure Control

The camcorder controls the iris for you when the *AE* dial is set to *AUTO*. The camcorder adjusts brightness automatically under normal conditions. You might need to adjust brightness manually when the background is too bright or too dark in comparison with the subject.

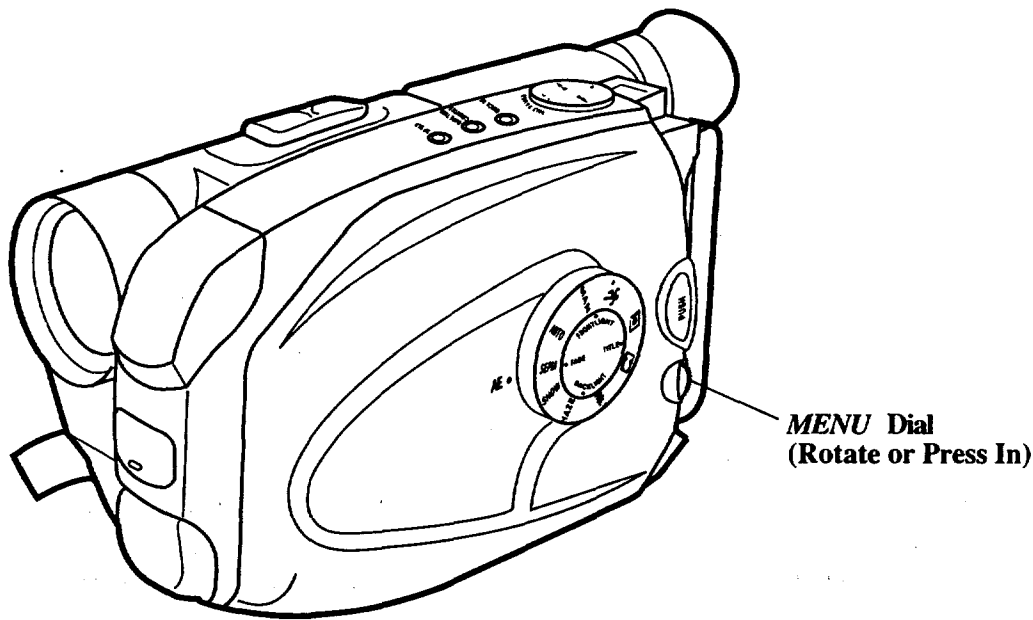

Auto Exposure

The camcorder adjusts the iris for the best possible picture during auto exposure.

- Set the *AE* dial to *AUTO* to turn on the auto exposure feature. No exposure indicator appears in the viewfinder.

Manual Exposure

You may need to adjust exposure manually under certain conditions, such as those listed *on the next page*.

1. Set the *POWER* switch to *CAMERA*, and make sure the *AE* dial is not set to *AUTO*.

Exposure Control (continued)

- Press the *MENU* dial in to display the main *MENU* in the viewfinder.

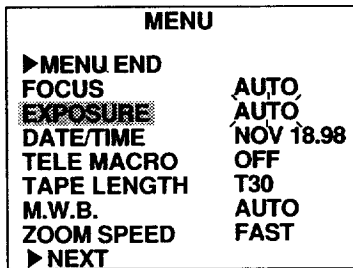

- Rotate the *MENU* dial to highlight *EXPOSURE* and press the dial in to display the *EXPOSURE* menu.

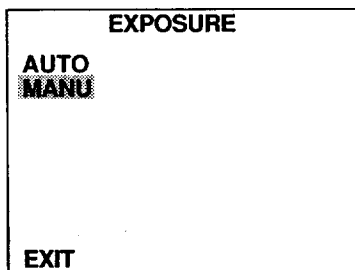

- Rotate the *MENU* dial to highlight *MANU* (manual) and press the dial in.

The exposure indicator (00) appears in the viewfinder.

- Adjust the exposure for a dark or bright subject.
 - To brighten the image, rotate the *MENU* dial up. You can adjust the exposure to +06.
 - To darken the image, rotate the *MENU* dial down. You can adjust the exposure to -06.
- Press the *MENU* dial in to select an exposure.
- Press *MENU* again to remove the main *MENU*.

Notes: To return to auto exposure, select *AUTO* in the *EXPOSURE* menu or set the *AE* dial to *AUTO*.

Conditions Requiring Manual Exposure

- When recording with a bright background or reverse lighting.
- When recording with a very dark background or very bright subject.
- When recording a reflective natural background — such as a beach or when skiing.

Fade In or Out

You can add a professional touch to your recordings when you fade in and out of scenes. The picture gradually appears or disappears. The speed of the fade is controlled by the camcorder.

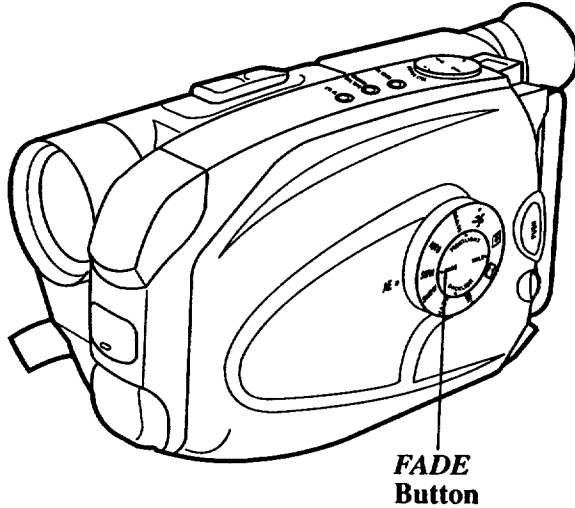

To Fade In or Out

1. Set *POWER* switch to *CAMERA*.
You can activate fading during record-pause or recording.

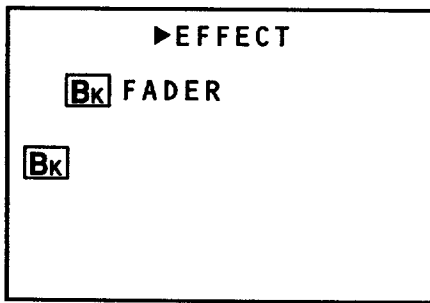

2. Press the *FADE* button. **BK FADER** appears briefly and then **BK** remains in the viewfinder.
3. Press the thumb trigger to start or stop recording. The camcorder fades in or out of the scene.

Notes: Press and hold the thumb trigger to record a black screen.

The screen becomes slightly reddish if fade is used with the sepia feature.

If the haze feature is selected, fading is in and out from a white screen.







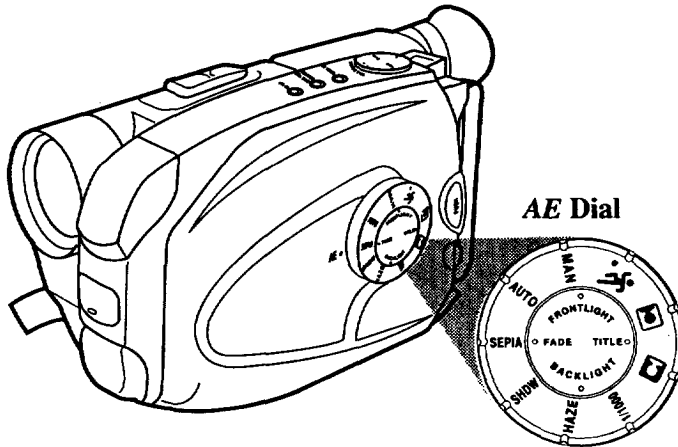

To Turn Off the Fade Feature

Press the *FADE* button while **BK** appears in the viewfinder. *OFF* appears briefly when the fade feature is turned off.

AE Dial

The *AE* dial lets you select one of several different effects. Turn the dial to select the effect you want. The name and indicator for the effect appears briefly and then the indicator remains. There are no indicators for *AUTO* or *MAN*. Set the *AE* dial to *MAN* for normal recording.



Mode	Name and Indicator	Uses
<i>AUTO</i>	<i>AUTO LOCK</i>	Places camcorder in full auto mode. Time and date displays, title, manual focus, manual exposure, and manual white balance will not operate.
<i>MAN</i>	<i>AUTO RELEASE</i>	Use this mode for recording using some of the manual features.
	 <i>SPORTS</i>	Use to capture fast-moving action with less blurring. Use when playing back a recording on a VCR featuring special effects, such as pause or slow motion.
	 <i>BACK LIT</i>	Use when subjects are in front of a window or have the sun to their back. Compensates for subjects appearing too dark because of backlighting.
	 <i>FRONT LIT</i>	Use when there is a strong front light on the subject such as spotlights. Compensates for subjects appearing too light because of strong front lighting.
<i>1/1000</i>	 <i>1 S 1/1000</i>	Sets shutter speed to 1/1000. Use to record faster moving action than sports mode with less blurring. Use when playing back a recording on a VCR featuring special effects, such as pause or slow motion.
<i>HAZE</i>	<i>HZ:HAZE</i>	Use to soften the image and give the picture a misty white effect.
<i>SHDW</i>	<i>SD:SHADOW</i>	Use to counter effects of glare and darken the picture with a black mist.
<i>SEPIA</i>	 <i>SEPIA</i>	Picture is recorded in sepia (brownish red) and offers the vintage look of old movies.

Front Light and Back Light

The camcorder adjusts the light automatically under normal conditions. You might need to adjust for a strong front light or back light (such as spotlights or subjects standing in front of a window with the sun at their backs). You can adjust for a strong front or back light using the *AE* dial, *FRONTLIGHT* button, or *BACKLIGHT* button.

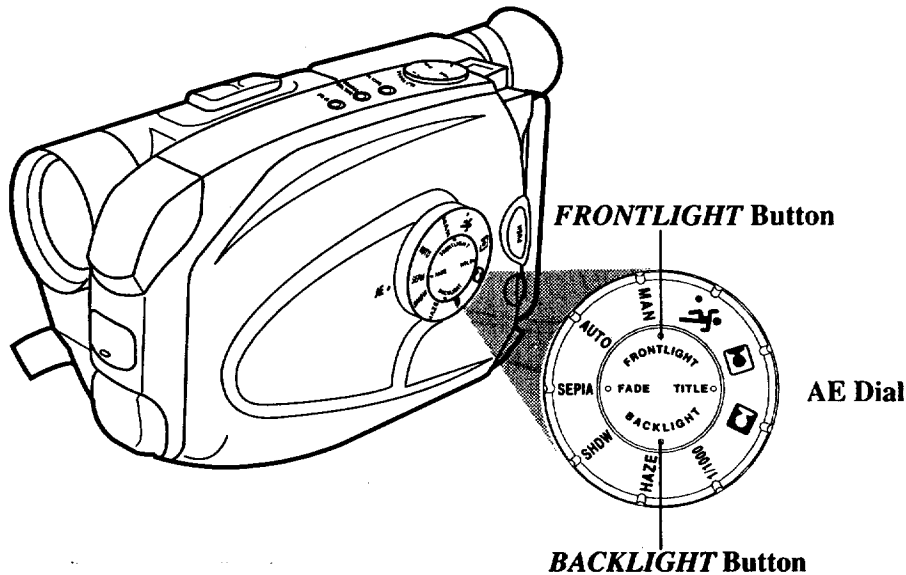

To Use the AE Dial

- To compensate for a strong front light, place the *AE* dial in front light (☀️). *FRONT LIT* appears briefly and then ☑️ remains in the viewfinder.
- To compensate for a strong back light place the *AE* dial in back light (🌑). *BACK LIT* appears briefly and then ☑️ remains in the viewfinder.
- Set the *AE* dial to *AUTO* to turn off the front or back light feature.

To Use the *FRONTLIGHT* or *BACKLIGHT* Button

You may want to temporarily adjust for a strong front or back light using the *FRONTLIGHT* or *BACKLIGHT* button.

- To compensate for a strong front light, press and hold the *FRONTLIGHT* button. ☑️ and the exposure indicator (-02) appear in the viewfinder.

Note: The exposure indicator shows a setting two steps lower (up to -06) than the current exposure setting.

- To compensate for a strong back light, press and hold the *BACKLIGHT* button. ☑️ and the exposure indicator (+02) appear in the viewfinder.

Note: The exposure indicator shows a setting two steps higher (up to +06) than the current exposure setting.

- Release the button to turn off manual front or back light.

Travel Tips

- Write down your camcorder's serial number and keep it separate from the camcorder when traveling. If your camcorder is lost or stolen, you will be able to identify it.
- Use extra care to avoid damage to your camcorder and accessories when operating them at a beach or pool. Spray, sand, and dust should be avoided. If your lens has been exposed to the elements, clean it only with proper lens cleaning supplies.
- Make sure you have any plug adapters that you might need before taking your camcorder to other countries. Consult your dealer for advice.
- Carry your camcorder in a carrying case when traveling. *See page 70* for a case designed especially for this camcorder. An ordinary suitcase or carry bag does not offer the protection your camcorder needs. Treat your camcorder as carry-on luggage to protect it from rough handling.

Titles — Recording

The title feature lets you choose one of eight preset titles or create your own title — up to 18 characters. You must install the clock cell battery *as shown on page 17* before you can create or store your own title.

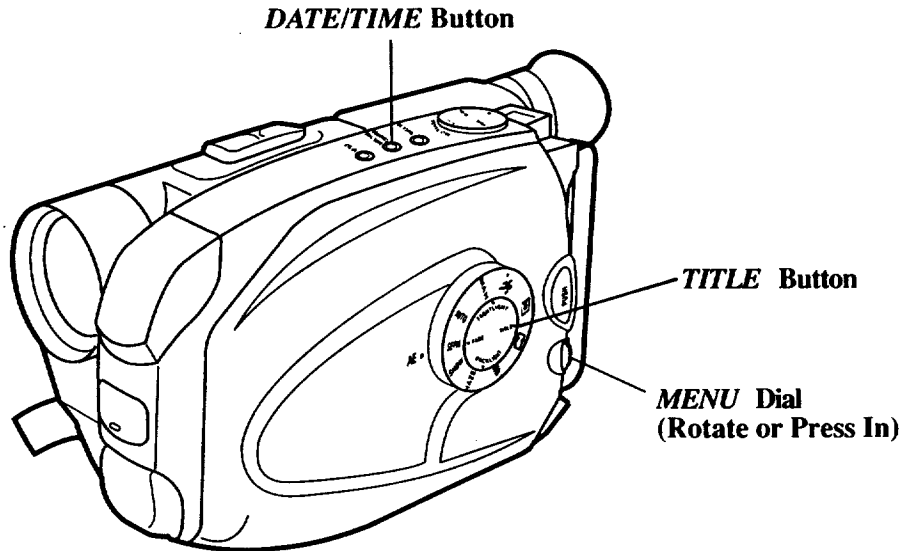

Record a Preset Title or Title You Create

1. Make sure the camcorder is in record-pause and the *AE* dial is not set to *AUTO*.
2. Repeatedly press *TITLE* to select one of the preset titles or the title you created.
3. Start recording. The title is superimposed and recorded on your tape whenever it appears.

HAPPY BIRTHDAY
HAPPY HOLIDAYS
CONGRATULATIONS
OUR FAMILY

SOMEONE SPECIAL
VACATION
SUPER STAR
FIRST

Title you Created

Title Off — No Title

4. Press *TITLE* to remove the title from the viewfinder when you are finished recording it.

Recording

Create Your Own Title

1. Make sure the camcorder is in record-pause and the *AE* dial is not set to *AUTO*.
2. Press the *MENU* dial in to display the main *MENU* in the viewfinder.

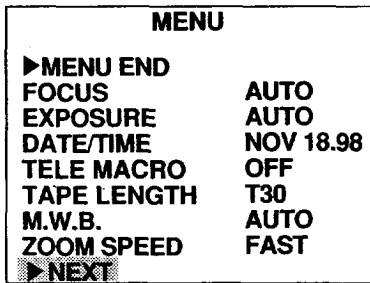

3. Rotate the *MENU* dial to highlight *NEXT*. The second *MENU* will appear. Keep rotating the *MENU* dial to highlight *CHARACTER*.

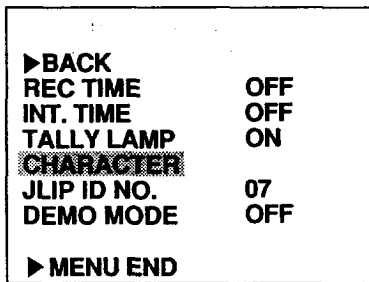

4. Press the *MENU* dial in to display the *CHARACTER* menu.

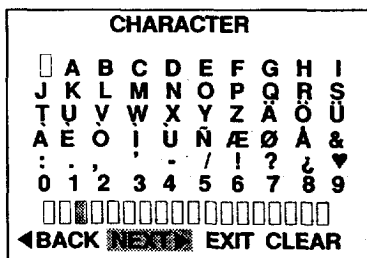

5. Rotate the *MENU* dial to highlight *BACK* or *NEXT*. Repeatedly press the *MENU* dial in to highlight the box

where you want the character to appear.

6. When the box is highlighted, rotate the *MENU* dial to select a character. Press the *MENU* dial in to place the character in your title.
7. Repeat steps 5 and 6 until you complete your title.

Note: To erase a previous title, rotate the *MENU* dial to highlight *CLEAR*, and press the *MENU* dial in to erase the title.

To change or delete a character, highlight *BACK* or *NEXT* and press the *MENU* dial in to highlight the character you want to change. Rotate the *MENU* dial to select the new character (or blank space) and press the *MENU* dial in to select the new character.

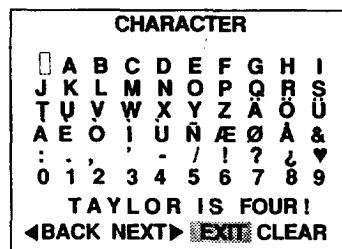

8. When you are finished, rotate the *MENU* dial to highlight *EXIT* and press the *MENU* dial in **twice** to remove the menu.

To record your title, press the *TITLE* button until your title is displayed as described on the previous page. To record your title and a preset title, display the preset title and press *DATE/TIME* to display your title as described on pages 20-21.

To Stop Recording Your Title

Press the *DATE/TIME* button and/or *TITLE* button to remove the title from the viewfinder.

Recording

Self-Timer Recording

You can set the self-timer to delay recording so you can be in the scene when recording begins.

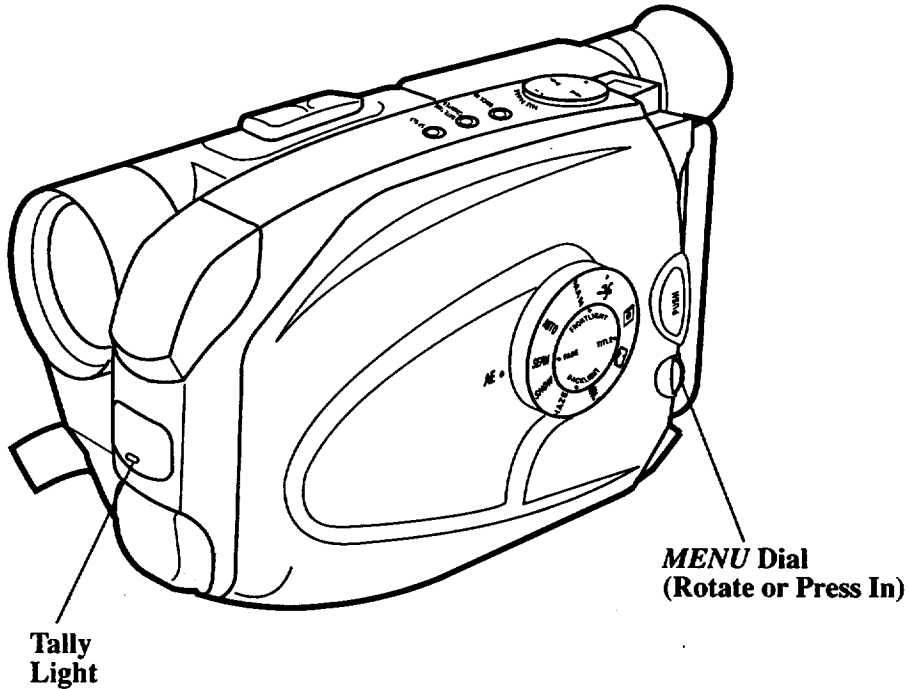

To Set the Self Timer

1. Make sure the camcorder is in record-pause and the *AE* dial is not set to *AUTO*.
2. Press the *MENU* dial in to display the main *MENU* in the viewfinder.

MENU	
▶MENU END	
FOCUS	AUTO
EXPOSURE	AUTO
DATE/TIME	NOV 18.98
TELE MACRO	OFF
TAPE LENGTH	T30
M.W.B.	AUTO
ZOOM SPEED	FAST
▶NEXT	

Self-Timer Recording (continued)

3. Rotate the *MENU* dial to highlight *NEXT*. The second *MENU* appears. Keep rotating the *MENU* dial to highlight *INT. TIME*.

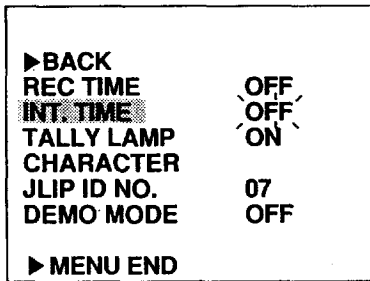

4. Press the *MENU* dial in to display the *INT. TIME* menu.

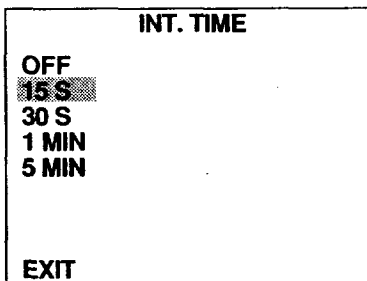

5. Rotate the *MENU* dial to highlight the desired time (*15S*, *30S*, *1 MIN*, or *5 MIN*).
 - Select *15S* to delay the recording for 15 seconds.
 - Select *30S* to delay the recording for 30 seconds.
 - Select *1MIN* to delay the recording for one minute.
 - Select *5MIN* to delay the recording for five minutes.
 - Select *OFF* if you do not want the camcorder to delay recording.

6. Press the *MENU* dial twice to exit the menu.
7.  and the amount of delayed recording time appear in the viewfinder.

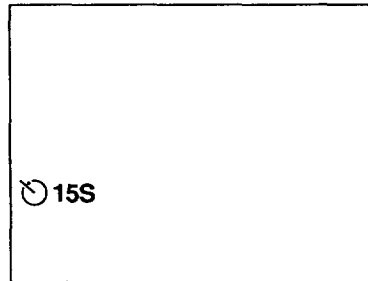

8. Press the thumb trigger to start recording.

Note: The tally light flashes. About five seconds before recording begins, the tally light starts flashing faster. When the camcorder starts recording, the tally light stops flashing.

9. To stop self-timer recording, press the thumb trigger.

Note: To turn off self-timer recording before it starts, press the thumb trigger and set the interval time on the *INT. TIME* menu to *OFF*.

Animation Recording

You can produce an illusion of movement for an otherwise stationary scene or object by shooting a series of pictures of slightly different poses (such as cartooning).

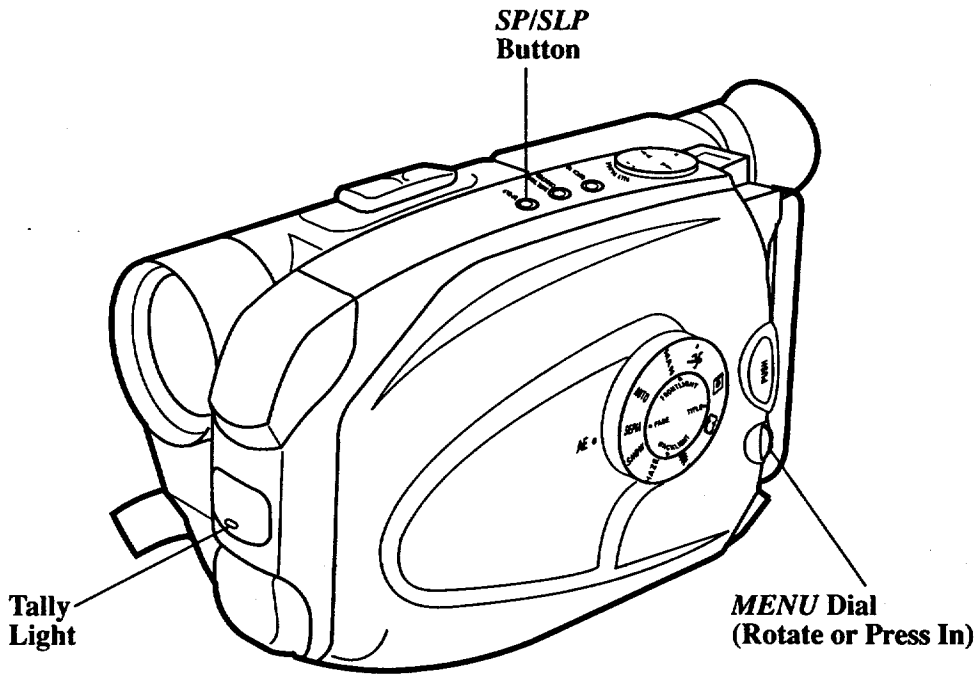

To Record Using Animation

1. Make sure the camcorder is in record-pause and the *AE* dial is not set to *AUTO*.
2. Press and hold *SP/SLP* to select *SP*. *SP* appears in the viewfinder.
3. Press the *MENU* dial in to display the main *MENU* in the viewfinder.

MENU	
▶MENU END	
FOCUS	AUTO
EXPOSURE	AUTO
DATE/TIME	NOV 18.98
TELE MACRO	OFF
TAPE LENGTH	T30
M.W.B.	AUTO
ZOOM SPEED	FAST

Animation Recording (continued)

4. Rotate the *MENU* dial to highlight *NEXT*. The second *MENU* appears. Keep rotating the *MENU* dial to highlight *REC TIME*.

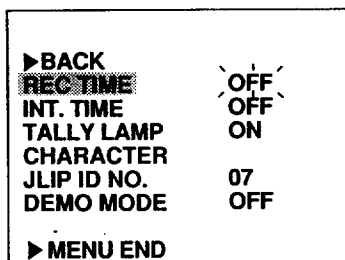

5. Press the *MENU* dial in to display the *REC TIME* menu.

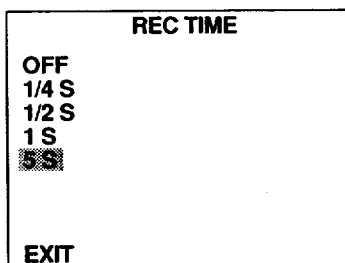

6. Rotate the *MENU* dial to highlight the amount of time you want the camcorder to record.

- Select *1/4S* to record for 1/4 second.
- Select *1/2S* to record for 1/2 second.
- Select *1S* to record for one second.
- Select *5S* to record for five seconds.

- Select *OFF* if you do not want to record for a selected amount of time.

7. Press the *MENU* dial twice to exit the menu.

8.  and the amount of recording time appear in the viewfinder.

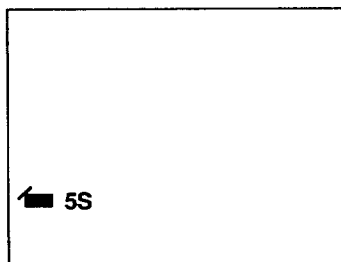

9. Press the thumb trigger to start recording.

Note: The recording stops automatically after the selected period of recording time. You might want to take two to five shots of the subject in the same position.

10. Move the subject and repeat step 9 for the desired number of shots.

11. To stop animation recording, set the time in the *REC TIME* menu to *OFF*.

Time-Lapse Recording

You can make automatic recordings at preset time intervals. The recording shows subtle changes (such as shifts in cloud formations or plant growth) when it remains focused on an object.

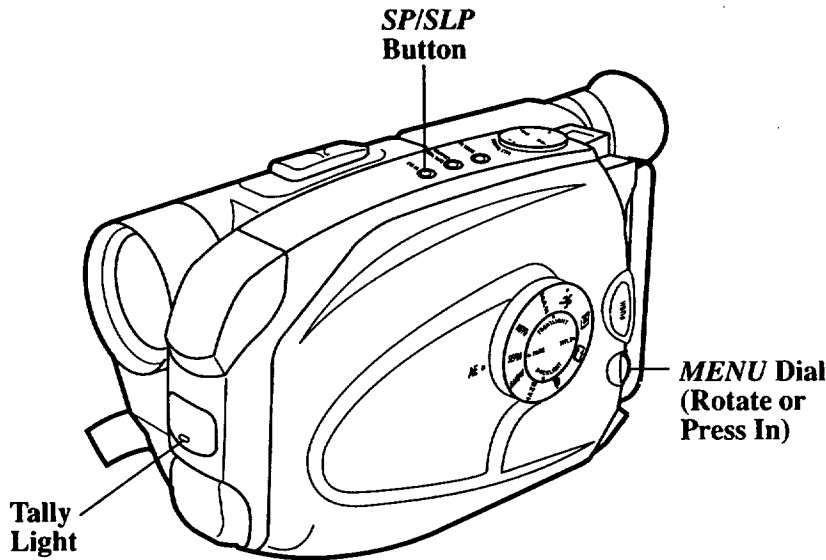

To Record Using Time Lapse

1. Make sure the camcorder is in record-pause and the *AE* dial is not set to *AUTO*.
2. Press and hold *SP/SLP* to select *SP*. *SP* appears in the viewfinder.
3. Press the *MENU* dial in to display the main *MENU* in the viewfinder.

Keep rotating the *MENU* dial to highlight *INT. TIME*.

MENU	
▶MENU END	
FOCUS	AUTO
EXPOSURE	AUTO
DATE/TIME	NOV 18.98
TELE MACRO	OFF
TAPE LENGTH	T30
M.W.B.	AUTO
ZOOM SPEED	FAST
▶NEXT	

▶BACK	
REC TIME	OFF
INT. TIME	OFF
TALLY LAMP	ON
CHARACTER	
JLIP ID NO.	07
DEMO MODE	OFF
▶MENU END	

4. Rotate the *MENU* dial to highlight *NEXT*. The second *MENU* appears.

5. Press the *MENU* dial in to display the *INT. TIME* menu.

INT. TIME
OFF
30 S
1 MIN
5 MIN
EXIT

Recording

Time-Lapse Recording (continued)

6. Rotate the *MENU* dial to highlight the desired time between recordings (*15S*, *30S*, *1 MIN*, or *5 MIN*).
 - Select *15S* to delay the recording for 15 seconds.
 - Select *30S* to delay the recording for 30 seconds.
 - Select *1MIN* to delay the recording for one minute.
 - Select *5MIN* to delay the recording for five minutes.
 - Select *OFF* if you do not want the camcorder to delay recording.
7. Press the *MENU* dial in to display the second *MENU*. Rotate the *MENU* dial to highlight *REC TIME*.

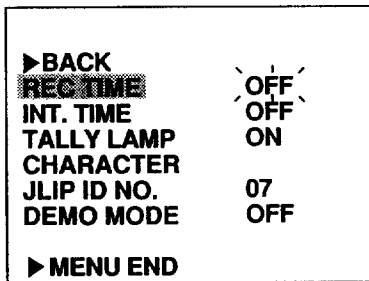

8. Press the *MENU* dial in to display the *REC TIME* menu.

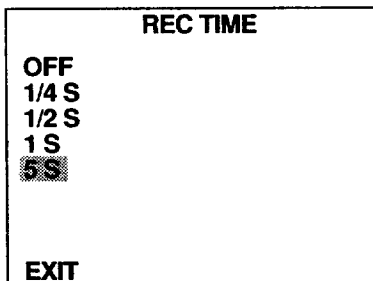

9. Rotate the *MENU* dial to highlight the amount of time you want the camcorder to record.

- Select *1/4S* to record for 1/4 second.
- Select *1/2S* to record for 1/2 second.
- Select *1S* to record for one second.
- Select *5S* to record for five seconds.
- Select *OFF* if you do not want to record for a selected amount of time.

10. Press the *MENU* dial twice to exit the menus.

← and the amount of recording time and ☺ and the amount of interval time between recordings appear in the viewfinder.

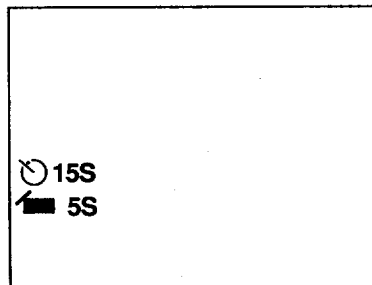

11. Press the thumb trigger to start recording.

Note: The camcorder starts and stops recording the selected amount of time. The tally light flashes with the flash speed increasing five seconds before recording begins.

12. To stop recording, place the camcorder in record-pause, and set the *REC TIME* and *INT. TIME* in the second *MENU* to *OFF*.

Note: Fade does not operate during animation or time-lapse recording.

Recording

Tally Light (Turn On or Off)

You can turn the tally light on or off using the second *MENU*.

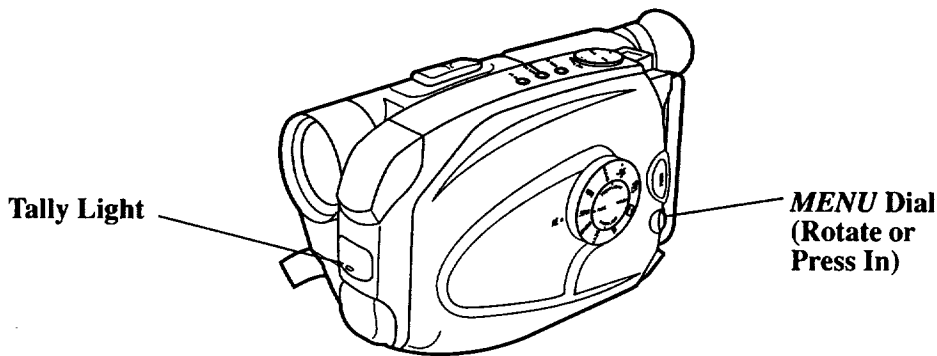

To Turn the Tally Light On or Off

1. Make sure the camcorder is in record-pause and the *AE* dial is not set to *AUTO*.
4. Press the *MENU* dial in to display the *TALLY LAMP* menu.

2. Press the *MENU* dial in to display the main *MENU* in the viewfinder.

MENU	
▶MENU END	
FOCUS	AUTO
EXPOSURE	AUTO
DATE/TIME	NOV 18.98
TELE MACRO	OFF
TAPE LENGTH	T30
M.W.B.	AUTO
ZOOM SPEED	FAST
▶NEXT	

TALLY LAMP	
ON	
OFF	
EXIT	

3. Rotate the *MENU* dial to highlight *NEXT*. The second *MENU* will appear. Keep rotating the *MENU* dial to highlight *TALLY LAMP*.

5. Rotate the *MENU* dial to highlight *OFF* or *ON*. Press the *MENU* dial in to select *ON* or *OFF*.
 - Select *ON* if you want the tally light to light during recording.
 - Select *OFF* if you do not want the tally light to light during recording.
6. Rotate the *MENU* dial to highlight *EXIT* and press the dial in twice to remove the menus.

▶BACK	
REC TIME	OFF
INT. TIME	OFF
▶TALLY LAMP	ON
CHARACTER	
JLIP ID NO.	07
DEMO MODE	OFF
▶MENU END	

Demo Mode

You can turn on the *DEMO* mode in the second *MENU* to have a demonstration of some of the camcorder's features.

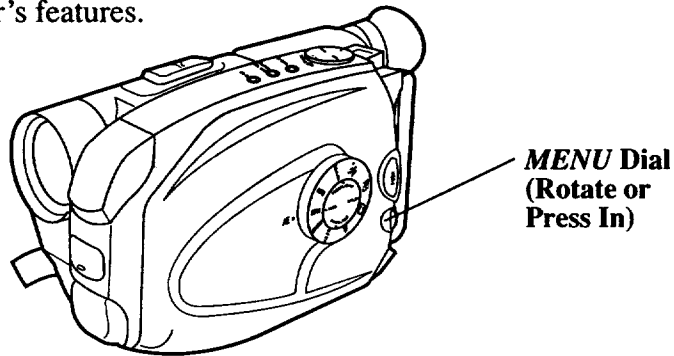

To Turn the Demo Mode On

1. Make sure the camcorder is in record-pause and the *AE* dial is not set to *AUTO*.
2. If a cassette is inserted, remove the safety tab or set it to *REC OFF*.
3. Press the *MENU* dial in to display the main *MENU* in the viewfinder.
5. Press the *MENU* dial in to display the *DEMO MODE* menu.

MENU	
▶MENU END	
FOCUS	AUTO
EXPOSURE	AUTO
DATE/TIME	NOV 18.98
TELE MACRO	OFF
TAPE LENGTH	T30
M.W.B.	AUTO
ZOOM SPEED	FAST
▶NEXT	

DEMO	
OFF	
ON	
EXIT	

4. Rotate the *MENU* dial to highlight *NEXT*. The second *MENU* appears. Keep rotating the *MENU* dial to highlight *DEMO MODE*.
6. Rotate the *MENU* dial to highlight *OFF* or *ON*. Press the *MENU* dial in to select *ON* or *OFF*.
 - Select *ON* if you want the camcorder to demonstrate some of the recording features.
 - Note: Zoom is the only feature that operates during the demo mode.
 - Select *OFF* if you do not want a demonstration.
7. Rotate the *MENU* dial to highlight *EXIT* and press the dial in twice to remove the menus.

▶BACK	
REC TIME	OFF
INT. TIME	OFF
TALLY LAMP	ON
CHARACTER	
JLIP ID NO.	07
DEMO MODE	OFF
▶MENU END	

To Turn the Demo Mode Off

Turn off the camcorder.

JLIP (Joint Level Interface Protocol) Identification Number

You can connect a device, such as a home computer, to the *JLIP* connector on the camcorder.

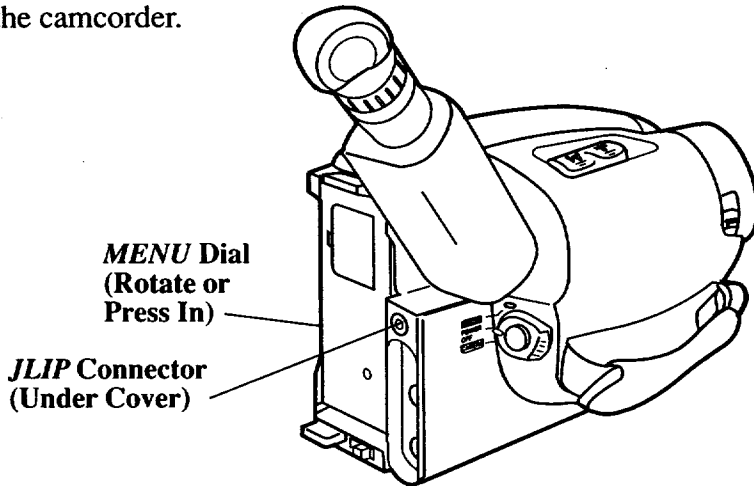

To Select a *JLIP ID NO.*

1. Make sure the camcorder is in record-pause and the *AE* dial is not set to *AUTO*.
2. Press the *MENU* dial in to display the main *MENU* in the viewfinder.
4. Press the *MENU* dial in to display the *JLIP ID NO.* menu.

MENU	
▶MENU END	
FOCUS	AUTO
EXPOSURE	AUTO
DATE/TIME	NOV 18.98
TELE MACRO	OFF
TAPE LENGTH	T30
M.W.B.	AUTO
ZOOM SPEED	FAST
▶NEXT	

JLIP ID NO.	
ID NO.	84
EXIT	

3. Rotate the *MENU* dial to highlight *NEXT*. The second *MENU* will appear. Keep rotating the *MENU* dial to highlight *JLIP ID NO.*

▶BACK	
REC TIME	OFF
INT. TIME	OFF
TALLY LAMP	ON
CHARACTER	
JLIP ID NO.	07
DEMO MODE	OFF
▶ MENU END	

5. Press the *MENU* dial in to start the *ID NO.* (numbers) flashing. Rotate the *MENU* dial to select a number from 01 to 99. Press the *MENU* dial in to select a *JLIP* number.

Use the number you select to identify your camcorder if you connect it to a computer using the *JLIP* connector.

6. Rotate the *MENU* dial to highlight *EXIT* and press the dial in **twice** to remove the menus.

Attach the Shoulder Strap

The camcorder's shoulder strap is designed to let you carry the camcorder from your shoulder and – when you are ready to shoot – bring the camcorder to shooting position in one quick movement.

To Attach the Shoulder Strap

1. If the strap keeper is over a double section of the strap, slide the strap keeper off the end of the strap. Replace the keeper on the strap between the buckle and the end of the strap *as shown*.

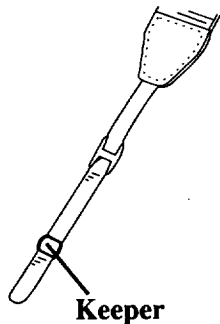

2. Loop the end of the strap over the top of the shoulder strap attachment ring.

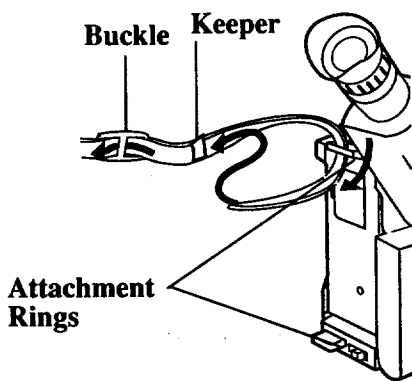

3. Thread the end of the strap back through the keeper and buckle making sure it is threaded under the outer strap. Make sure the strap is not twisted.

4. Attach the other end of the strap to the other shoulder strap attachment ring.

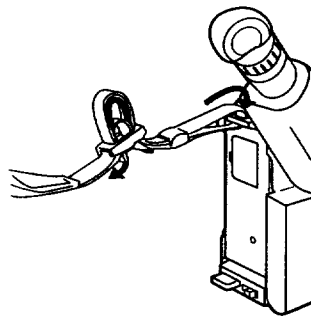

5. Adjust the shoulder strap to the desired length.
6. Slide both keepers up snugly against the shoulder strap attachment rings to prevent the strap from slipping.

Cautions: When carrying the camcorder with the shoulder strap, you may find it convenient to rotate the viewfinder down and slide it to the front. This helps prevent possible damage to the viewfinder from bumping against your body as you move.

Make sure the shoulder strap is firmly attached before using it to carry the camcorder.

Model CC6271 Only: Built-In Color Enhancement Light

Model CC6271's built-in color enhancement light automatically adds more light when needed. The *POWER* switch must be set to *CAMERA* to operate the video light.

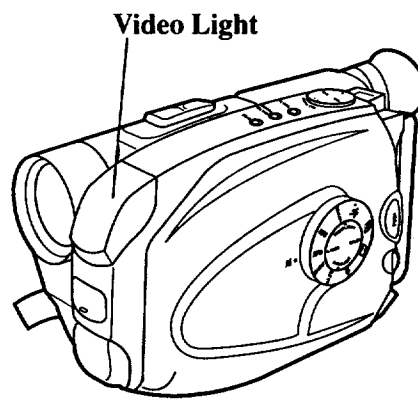
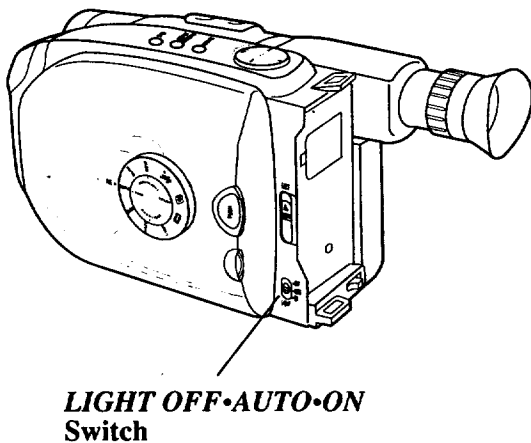

To Use the Light

Set the *LIGHT OFF•AUTO•ON* switch.

- Set to *ON* to turn the light on.
Note: We recommend you set white balance to $\frac{1}{2}$ *HALOGEN* in the *M.W.B.* menu when using the light.
- Set to *AUTO* to have the light come on automatically when the camcorder senses there is insufficient light for the best recording.

Notes: If the lighting condition is unstable the light might turn on and off. Set the light to *ON* or *OFF*.

The light might stay on when using high shutter speeds.

- Set to *OFF* to turn the light off. Turn the light off when you are not recording to save battery power.

Note: When the light is turned on, the camcorder may turn off if the battery's power is low even though the battery level indicator is not flashing.

Cautions:

Do not operate the video light closer than one foot to people or other objects. The video light becomes very hot. Do not touch it during operating or right after using it. Serious injury may result. Do not place the camcorder in a carrying case right after using the light. Never operate the video light close to flammable or explosive material.

Model CC6271 Only: Built-In Color Enhancement Light (continued)

Replace the Bulb Assembly

Carefully follow the instructions below.

Cautions

The video light and bulb need to cool for approximately 30 minutes after the camcorder has been used before the bulb assembly is replaced.

Do not touch the light bulb with your fingers. If the bulb is accidentally touched, wipe it with a soft cloth. A dirty bulb may cause smoke and have a reduced service life.

To Replace the Bulb Assembly

1. Insert a flat nonmetallic object (such as a plastic screwdriver) in the hole.
3. Place the new bulb assembly into the camcorder by inserting the top first and then slide the assembly into place.

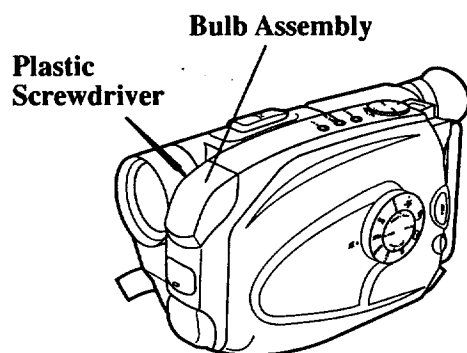

2. Pull on the sides of the bulb assembly and remove it from the camcorder *as shown*.

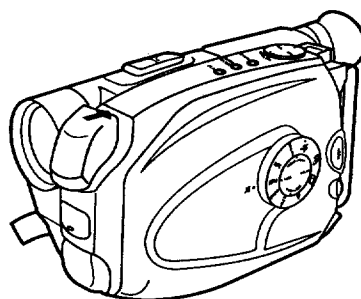
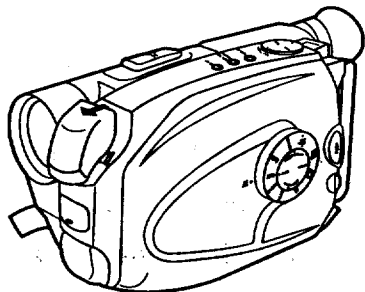

Playback

Use the Viewfinder for Playback

You can see tapes using the viewfinder. There is no sound during viewfinder playback.

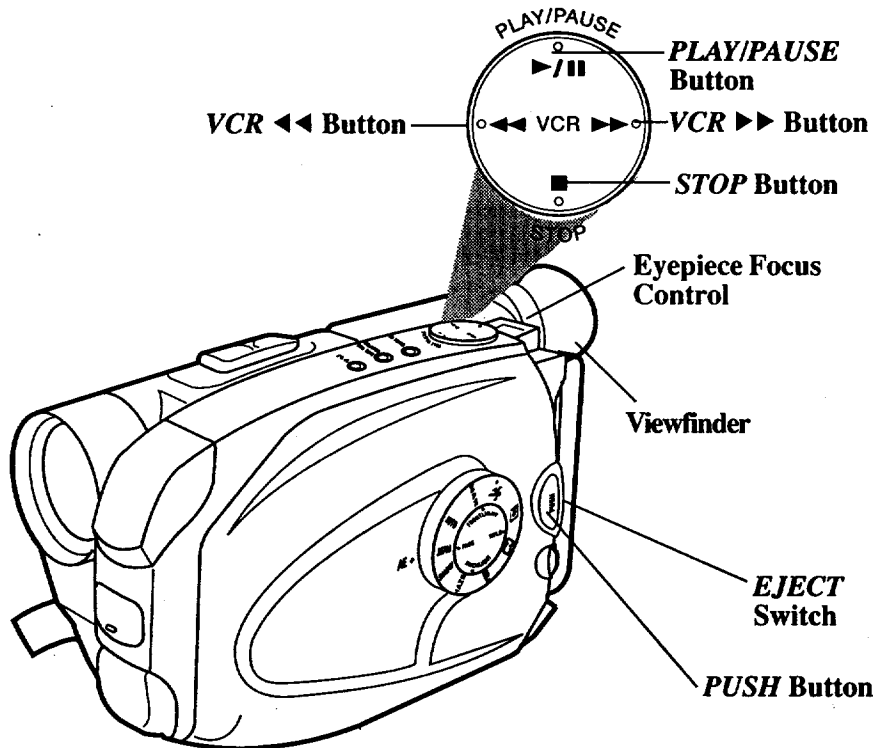

To Play Back a Tape

1. Attach a power supply.

Attach the adapter/charger, charged battery, or optional car cord.

2. Insert a tape.

- Slide *EJECT* up to open the cassette compartment.
- Turn the tape wheel on the cassette to remove any slack from the tape.

- Insert the cassette with the tape wheel facing up and the tape window facing out.
- Press on the *PUSH* button to lock the cassette compartment closed.

3. Set the *POWER* switch to *VCR*.

The power indicator lights.

4. Adjust the viewfinder for a comfortable viewing position.

Use the Viewfinder for Playback (continued)

- Turn the eyepiece focus control to adjust the focus of the viewfinder for your vision.
5. Press the **PLAY/PAUSE** button to begin playback.
 - If necessary, adjust tracking.
 6. Press the **STOP** button when you are finished.
- During playback, use the playback features *on the following pages*.

Tracking

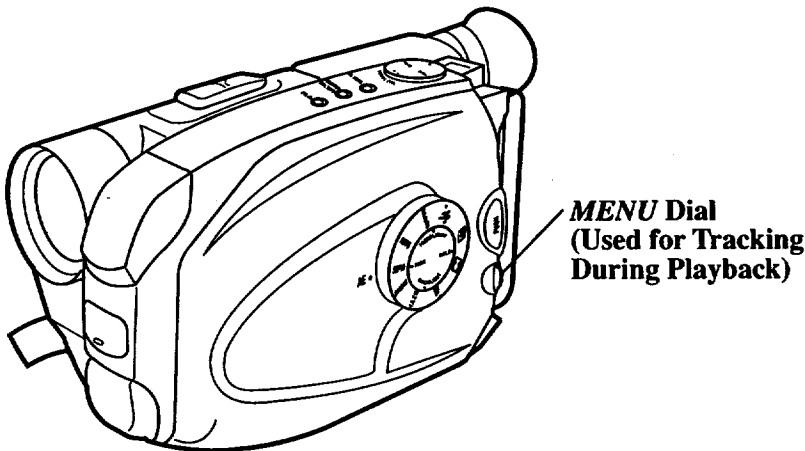

During playback, streaks may appear in the playback picture. Press the **MENU** dial in to activate manual tracking. Rotate it up or down to move the streaks up or down and out of the picture.

- During stop-action playback, rotating the **MENU** dial while in manual tracking might reduce picture “jitter”

(picture bouncing up and down). Some “jitter” is normal.

Press the **MENU** dial in again to turn automatic tracking back on. **AT** flashes in the viewfinder during automatic tracking.

Note: The tracking buttons might have no effect on tapes recorded on other camcorders or VCRs.

Playback Features

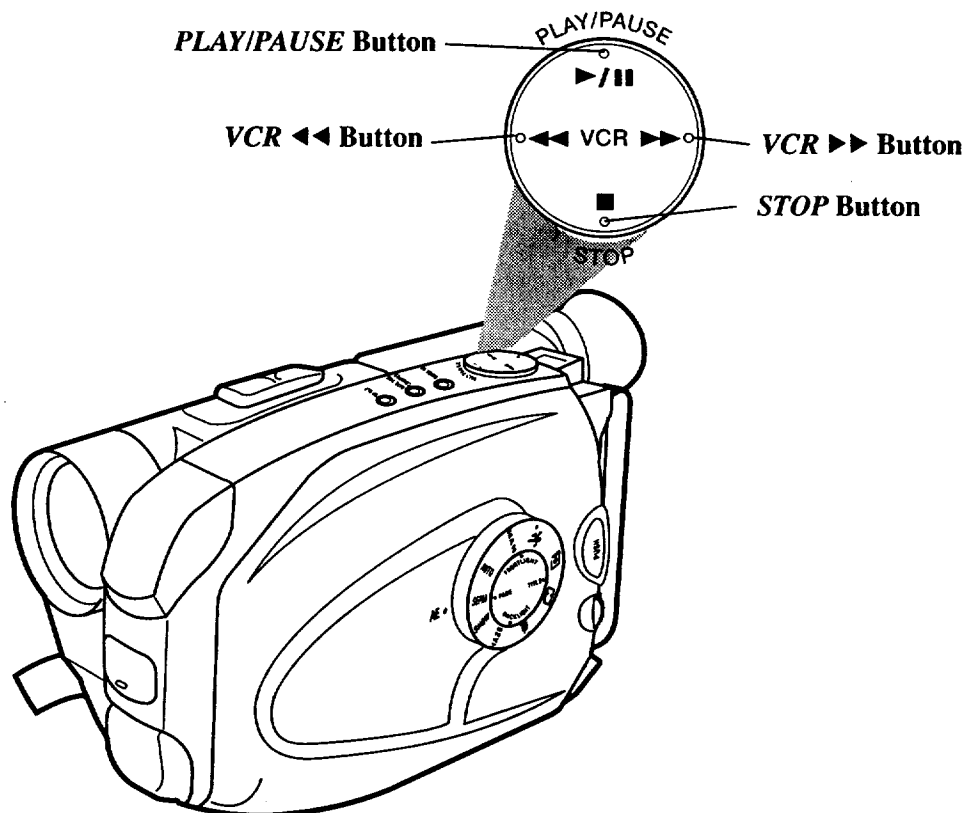

Position the Tape

Set *POWER* switch to *VCR* and press *STOP*.

- Press and quickly release the *VCR <<* button or *VCR >>* button to rewind or fast-forward the tape.
- Press *STOP* to stop the tape.

Visual Search

- During playback, press and release *VCR <<* button or *VCR >>* button if you want to search the tape visually in forward or reverse.
- Press *PLAY/PAUSE* to return to normal playback.

- For brief searching, press and hold *VCR <<* button or *VCR >>* button for more than two seconds.
- Release the button to return to normal playback.

Stop-Action Pause

- During playback, press *PLAY/PAUSE* to “stop the action” and view one frame of the tape.
- Press *PLAY/PAUSE* to return to normal playback.

Caution: Pause is designed for momentary interruptions and should not be used for an extended period of time. If the camcorder remains in pause for more than five minutes, it enters the stop mode and turns off to prevent excessive tape wear.

Playback Features (continued)

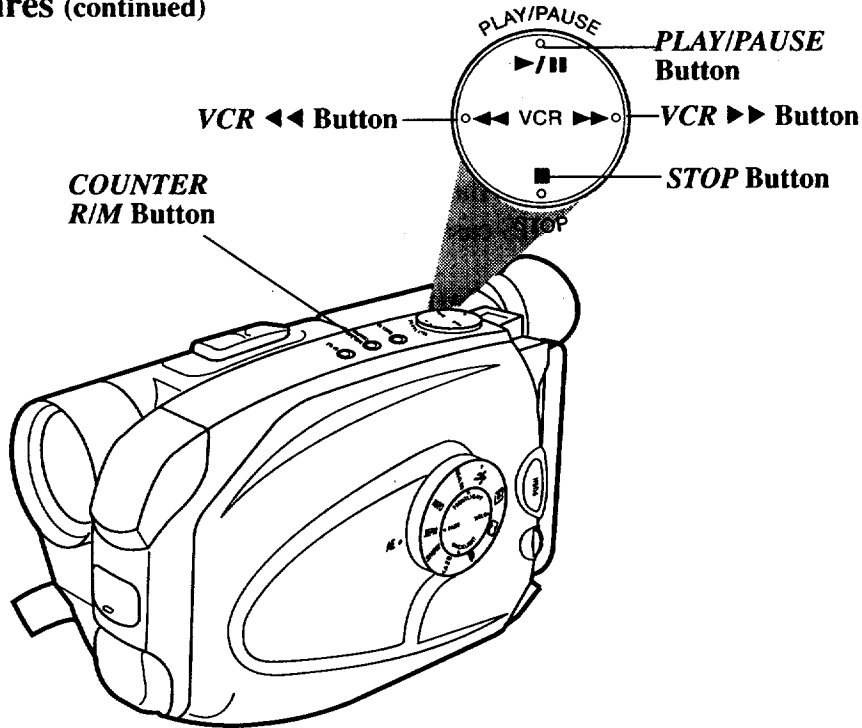

Time Counter

The time-counter display shows the actual time elapsed when playing back a segment of tape. The memory-stop feature helps locate a certain point on the tape. Turn memory stop on to stop the tape automatically during rewind or fast forward when the time counter reaches *M 0:00:00*.

To Use the Memory-Stop Feature

1. Locate the place on the tape you want to return to, set the *POWER* switch to *VCR*, and press *COUNTER R/M* for more than two seconds to reset the counter to *0:00:00*.
2. Press *COUNTER R/M* for less than one second to turn the time counter's memory-stop feature on or off. When memory stop is on, an *M* appears before the time counter.
3. Continue to play the tape. When you want to return to the place you marked, press the *STOP* button.
4. Press *VCR◀◀*. The tape rewinds to the time counter reading of *M 0:00:00*.

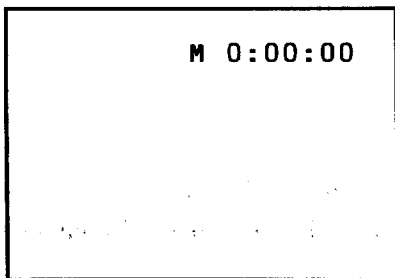

Time Counter With Memory Stop Turned On

Use the Cassette Adapter

The camcorder uses a smaller size cassette, but records in standard VHS format. The cassette adapter allows you to play your VHS-C cassettes in a VCR just like other standard VHS cassettes.

Insert the VHS-C cassette into the cassette adapter. Insert the cassette adapter into the VHS VCR like a normal VHS cassette.

Install Cassette Adapter's Battery

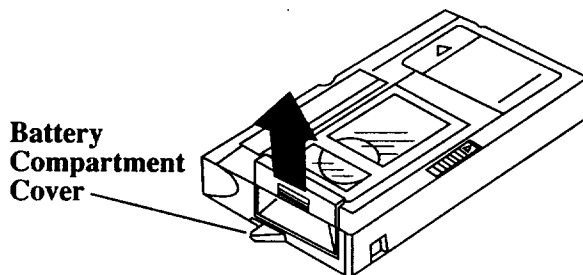

1. Remove battery compartment cover.
2. Install supplied "AA" battery so positive (+) and negative (-) ends align properly with (+) and (-) terminals in battery compartment.
3. Replace battery compartment cover.

Notes: Replace the battery when the load time becomes much longer than normal.

Remove the battery from the cassette adapter if it is not used for a month or more. This prevents possible damage from battery leakage. If leakage occurs, wipe up the liquid inside the compartment and replace the battery with a new one.

Insert Cassette into Cassette Adapter

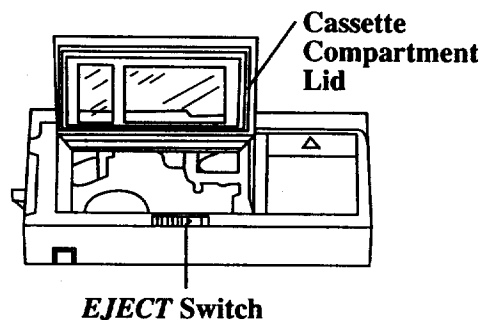
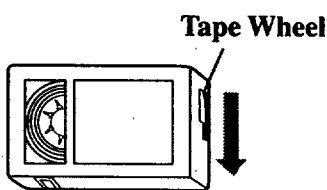

1. Before inserting the cassette into the adapter, remove any slack in the tape by turning the tape wheel on the side of the cassette.
2. Slide *EJECT* to the right to open the cassette compartment lid.
3. Insert the cassette with the tape window on the left and facing up. Allow the cassette to drop into the adapter. **Do not force the cassette.**

Use the Cassette Adapter (continued)

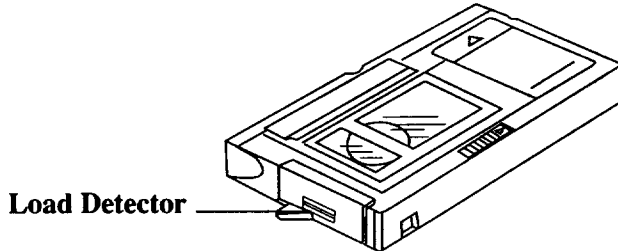

4. Gently close the cassette compartment lid until it locks into place. Make sure the cassette reel area under the adapter is free to turn while the cassette is loading.

Note: You should hear a whirring sound while the tape loads. The adapter's load detector will automatically retract into the adapter.

Caution: If the load detector is still extending from the side of the cassette adapter after you have attempted to load the cassette, loading is not complete. Try to load the cassette again. Attempting to insert the cassette adapter into a VCR with the load detector extending may cause damage to the adapter and/or VCR.

Remove Cassette from Cassette Adapter

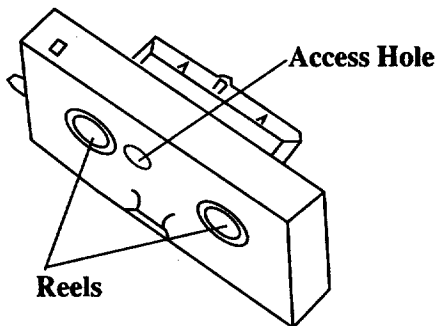

Caution: Do not touch the reels during loading and unloading. It could cause injury or damage the cassette adapter or tape.

1. Slide the adapter's *EJECT* switch to the right. The load detector extends from the side and the whirring sound indicates the tape is being released before the adapter's cassette compartment lid opens.
2. Use the access hole on the bottom of the adapter to push the cassette up and remove it from the adapter.
3. Gently close the adapter's cassette compartment lid.

Playback on TV (or VCR) with Audio/Video Inputs

To connect your camcorder to a TV monitor (or VCR) with audio/video inputs, you need an optional audio/video cable, such as VH83 *shown on page 72*. If your TV is already connected to a VCR, attach the camcorder to the VCR and watch what the camcorder is recording or playing on the TV.

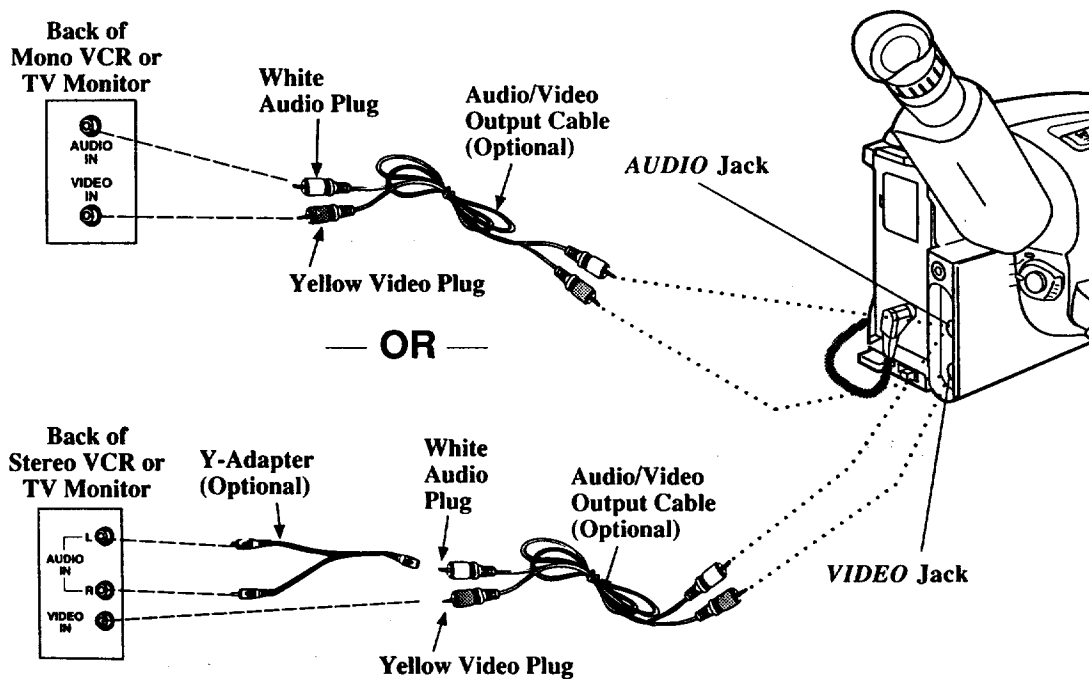

Installation

1. Attach the white plug on one end of the audio/video cable to the **AUDIO IN** jack on the TV (or VCR).
2. Attach the yellow plug to the **VIDEO IN** jack on the TV (or VCR).
3. Attach the white plug on the other end of the audio/video cable to the **AUDIO** jack (located under the small cover) on the back of the camcorder.
4. Attach the yellow plug to the yellow **VIDEO** jack on the camcorder.

Notes: If your cable does not have white and yellow plugs, attach the same color to the audio jacks.

If your TV (or VCR) has stereo **AUDIO IN** jacks, attach the plug to the one labeled **MONO**. If one is not labeled **MONO**, you need a Y-adapter, such as AH25, *shown on page 72* to hear both channels.

Playback

Playback on TV (or VCR) with Audio/Video Inputs (continued)

Playback Operation and How to Copy Tapes on the VCR

1. A. Camcorder connected directly to TV: Turn on the TV and tune it to the video input channel.
B. Camcorder connected to VCR that is already connected to TV: Turn on VCR and place it in the "line" or "camera mode". (If your VCR does not have a "line" or "camera mode", consult the VCR owner's manual.) Operate the TV as you normally do to see the signal coming from the VCR.
2. Set the *POWER* switch to *VCR* to turn on the camcorder. The power indicator lights.
3. Press *PLAY/PAUSE*.
 - During playback, use the playback features on pages 62-63.
4. To copy what the camcorder is playing, place a blank cassette in the VCR, and press the VCR's *RECORD* button.
Note: Make sure the memory-stop feature is turned off (press *COUNTER R/M*) or the camcorder enters play-pause when the counter reaches *M 0:00:00*.
5. Press *STOP* when you are finished.

Caution: The unauthorized recording of copyrighted material may infringe the rights of others.

Viewing What the Camcorder is Seeing (or Recording)

1. A. Camcorder connected directly to TV: Turn on the TV, and tune it to the video input channel.
B. Camcorder connected to VCR that is already connected to TV: Turn on VCR and place it in the "line" or "camera mode". (If your VCR does not have a "line" or "camera mode", consult the VCR owner's manual.) Operate the TV as you normally do to see the signal coming from the VCR.
2. Set the *POWER* switch to *CAMERA*.
Note: Turn the TV's volume down to prevent a high-pitched squeal caused by feedback.
3. Press the thumb trigger to begin recording. You can watch what the camcorder is seeing (or recording) on the TV screen.

Playback on a TV Without Audio/Video Inputs

To connect your camcorder to a TV without audio/video inputs, you need an optional 1CVA147C RF output adapter and an optional coaxial RF cable, such as VH82 or VH90 shown on page 72. If your TV has audio and video inputs (or is connected to a VCR), refer to pages 66-67.

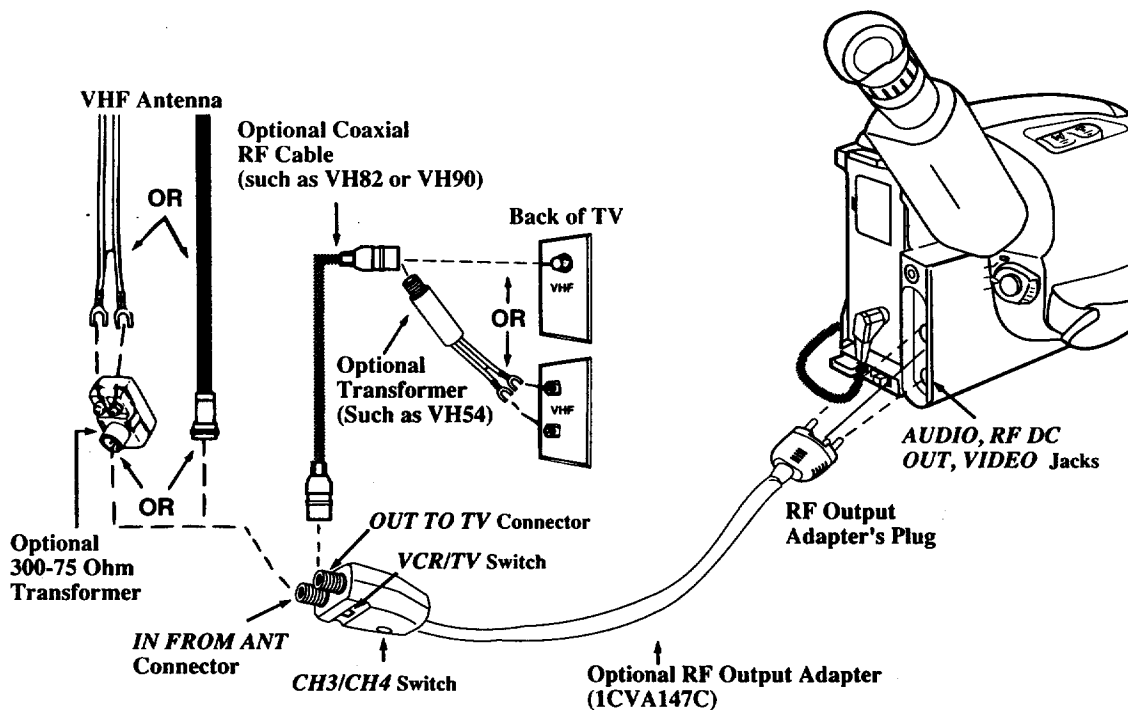

Installation

1. Disconnect the VHF antenna from your TV. Connect the antenna to the *IN FROM ANT* connector on the RF output adapter if you are going to leave the adapter connected to the TV.

Note: If your VHF antenna is the flat twin-lead type attached by two screws, you need an optional 300/75 ohm transformer.

2. Attach one end of the optional coaxial RF cable to the *OUT TO TV* connector on the adapter, and attach the other end to the VHF input on your TV as shown.

Note: If your TV has 300 ohm screw terminals, you need a 75/300 ohm transformer, such as VH54, shown on page 72.

3. Attach the RF output adapter's plug to the *AUDIO, RF DC OUT, and VIDEO* jacks located under the small cover on the back of the camcorder.

Playback

Playback on a TV Without Audio/Video Inputs (continued)

Playback Operation

1. Set the *CH3/CH4* switch on the RF output adapter to channel 3 or 4.
2. Turn on the TV, and tune it to the same channel you selected with the RF output adapter's *CH3/CH4* switch.
3. Place adapter's *VCR/TV* switch in *VCR*.
4. Set *POWER* switch to *VCR*. Power indicator lights.
5. Press *PLAY/PAUSE* on the camcorder.
 - During playback, use the playback features described on pages 62-63.
6. Press *STOP* on the camcorder when you are finished.

Seeing What the Camcorder Is Recording

1. Turn on the TV and tune it to channel 3 or 4. Turn the TV's volume down to prevent a high-pitched squeal caused by feedback.
2. Set the *CH3/CH4* switch on the RF output adapter to the same channel you selected on the TV.
3. Set adapter's *VCR/TV* switch to *VCR*.
4. Set *POWER* switch to *CAMERA*. Power indicator lights.
5. Press the thumb trigger to begin recording. You can watch what the camcorder is seeing (or recording) on the TV screen.

Normal TV Viewing

For normal TV viewing, leave the RF output adapter hooked up to the TV. Disconnect the adapter's plug from the

camcorder and place the adapter's *VCR/TV* switch in *TV*.

Note to Cable TV Installer

This reminder is provided to call your attention to Article 820-40 of the National Electrical Code (Section 54 of Canadian Electrical Code, Part I), that provides guidelines for proper grounding and, in particular, specifies that the cable ground shall be connected to the grounding system of the building as close to the point of cable entry as practical.

Optional Accessories

We invite you to take a look at some great ideas for sparking creativity and adding to the fun of using your compact VHS camcorder. The following pages have a selection of accessories to help make your memorable moments look and sound even better.

These accessories are designed to make the process of recording and watching your videos more enjoyable.

To order accessories, contact your local Dealer.

If a dealer is not nearby, all accessories are available through toll-free ordering or by using the order form *on page 73*.

AC201A Soft Carrying Case

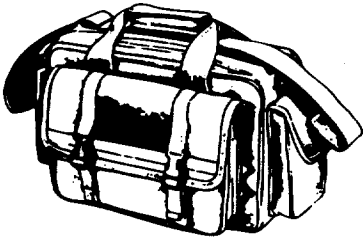

Custom compact soft case designed especially to provide protection and utility for your compact VHS camcorder and most accessories. Rugged fabric lined with soft non-abrasive material and generous padding. Has three outside pockets with storage for lens filters, adapters, batteries, and tapes.

DCC08 Car Cord Adapter

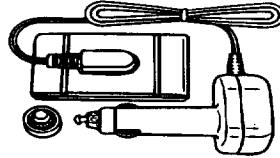

Do not use any other car cord with this camcorder.

This car cord adapter enables you to operate your camcorder from your car, truck, or RV by plugging the car cord directly into the vehicle's cigarette lighter socket. The DCC08 is designed specifically to convert power from a 12-volt battery to a 6-volt output.

Optional Accessories

FB1260 and FB120 Rechargeable Batteries

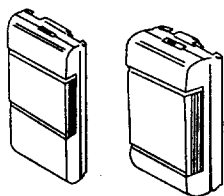

These rechargeable nickel-cadmium batteries are designed specifically for long life. The FB1260 is a 1-hour battery. The FB120 powers your camcorder twice as long as the FB1260 (depending on how much you use zoom and pause). Both can be recharged with the AC adapter/charger that came with your camcorder.

CPS91 AC Battery Charger

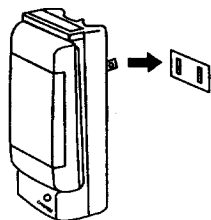

The CPS91 battery charger plugs directly into an AC outlet and charges the FB1260, BB700, and FB120 camcorder batteries. Because the CPS91 operates on 100-240 Volts, 50/60 Hz, it can be used virtually anywhere in the world. A plug adapter might be required in some countries. Charging takes approximately seven hours for the FB1260 (1-hour battery), 11 hours for the BB700, and 13 hours for the FB120 (2-hour battery).

Using the Optional AC088 Tripod

Mounting the camcorder on a tripod, such as AC088, keeps the camcorder steady and produces excellent video results.

This tripod's fluid-effect head provides smooth camera pan and tilt. The quick-release mount makes it easy to attach or remove the camcorder. The grooved, tubular 3-section leg design folds down to 26" when not in use. Rubber feet allow for sure footing.

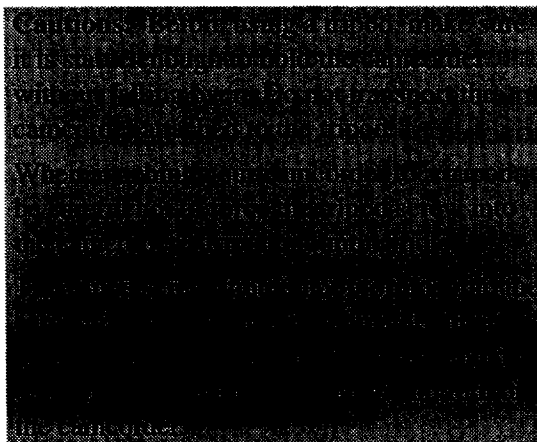
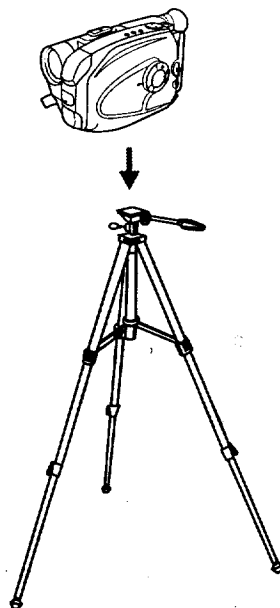

Optional Accessories

1CVA147C RF Output Adapter

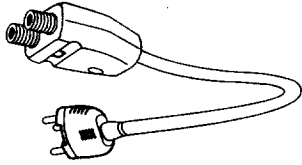

This RF output adapter is used with a coaxial RF cable, such as VH82 or VH90, to connect your camcorder to a standard TV (one without audio/video inputs) for playback. If your antenna cable is the flat twin-lead type attached by two screws, you need a 300-to-75 ohm transformer. If your TV has 300 ohm antenna screw terminals, you need an optional 75-to-300 ohm transformer such as VH54.

Coaxial RF Cables



VH82 (6-ft)
VH90 (12-ft)

These RF cables are used with the RF output adapter to connect your camcorder to a standard TV (one without audio/video input jacks) for playback. If your TV has 300 ohm antenna screw terminals, you need an optional 75-to-300 ohm transformer such as VH54. If your antenna cable is the flat twin-lead type attached by two screws, you need an optional 300-to-75 ohm transformer.

VH54 Cable Transformer



This 75-to-300 ohm transformer is used to connect a standard 75-ohm antenna cable (such as VH82 or VH90) to the 300 ohm screw terminals on a TV.

VH83 Audio/Video Cable

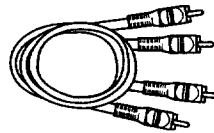

This six foot audio/video cable can be used to connect the camcorder to a TV monitor or VCR for tape playback or copying tapes.

AH25 Y-Adapter



This Y-adapter allows you to connect your camcorder's mono audio cable to a stereo TV or VCR.

Accessory Order Form

Order Form for Camcorder Model CC6151/CC6251/CC6271

Description	Part No.	Price	Qty.	Total
Super Lightweight Tripod	AC088	\$ 39.95		
Soft Camcorder Case	AC201A	\$ 39.95		
Shoulder Strap	ACS091	\$ 12.95		
Y-Adapter	AH25	\$ 2.95		
AC Battery Charger	CPS91	\$ 59.95		
Car Cord Adapter	DCC08	\$ 89.95		
Rechargeable Battery (Extended)	FB120	\$ 89.95		
Rechargeable Battery (Standard)	FB1260	\$ 49.95		
75-300 Cable Transformer	VH54	\$ 2.95		
Coaxial RF-Cable	VH82	\$ 6.95		
Audio/Video Cable	VH83	\$ 5.95		
Coaxial RF-Cable	VH90	\$ 7.95		
RF Output Adapter	1CVA147C	\$ 59.95		
AC Adapter/Charger and DC Cable	241017 233087	\$126.55 \$ 27.80		
Cassette Adapter	232845	\$ 71.35		
Bulb Assembly (Model CC6271)	233430	\$ 33.80		

Prices are subject to change without notice.

Total Merchandise \$ _____

Sales Tax \$ _____

We are required by law to collect the appropriate sales tax for each individual state, county, and locality to which the merchandise is being sent.

Shipping and Handling \$ 5.00

Total Amount Enclosed \$ _____

Use VISA, MasterCard, or Discover.
Money order or check must be in U.S. currency only. No COD or cash.

Detach Here

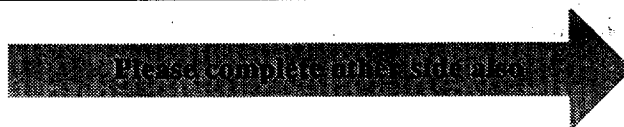

Charge your order on your VISA, MasterCard,
or Discover Card by filling in below

USE YOUR CREDIT CARD

IMPORTANT: Copy complete account number from your VISA card

Expiration date:



IMPORTANT: Copy complete account number from your MasterCard

Copy Number above your name on MasterCard Expiration date:



IMPORTANT: Copy complete account number from your Discover Card

Expiration date:



AUTHORIZED SIGNATURE

Prices are subject to change without notice.

Print or type your name and
address clearly.

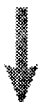

A complete and correct order will
save you days of waiting.

Name: _____
 Street: _____
 _____ Apt: _____
 City: _____
 State: _____ Zip: _____

Please make sure that both sides of this form have been filled out completely.

- Allow 4 weeks for delivery.
- All accessories are subject to availability.

✂ Detach Here

Accessory Order Form

To order accessories, contact your local Dealer.

If a dealer is not nearby, you can also follow the directions below to order by telephone or direct-by-mail.

United States and Canada Orders

To place your order by phone, have your Visa, MasterCard, or Discover card ready and call the toll-free number listed below between 8 AM and 10 PM (EST) Monday through Friday or between 9AM and 5PM (EST) Saturday.

Use this number only to place an order for accessory items listed on this order form.

1-800-338-0376

To place your order by mail, detach and mail the completed order form with credit card information, money order, or check in U.S. currency (made payable to Thomson Consumer Electronics, Inc.) to the following address:

Video Accessories
PO Box 8419
Ronks, PA 17573

Trouble Checks





Troubles sometimes are caused by simple “faults” that you can easily correct without the help of a service technician by first checking a few basic remedies.

Before you call or take your camcorder to an Authorized RCA Camcorder Service Center, look below for the type of trouble you are experiencing. Then perform the simple checks and adjustments listed for that trouble.

If service should be necessary, the warranty information lists what your warranty covers and explains how to get service.

Trouble	Checks and Adjustments
No power	<ul style="list-style-type: none"> • Set the <i>POWER</i> switch to <i>CAMERA</i> or <i>VCR</i> to turn on the camcorder. The power indicator lights. • If using battery, it might need to be recharged. • If using AC adapter/charger, make sure it is plugged into a working outlet.
Won't record or playback	<ul style="list-style-type: none"> • If using AC adapter/charger, make sure it is plugged into a working outlet. • If the dew indicator () flashes in the viewfinder, there is moisture in the camcorder. Wait until the dew indicator no longer appears before operating the camcorder. • Make sure <i>POWER</i> switch is set to correct position for desired operation. • There might not be a cassette in the camcorder. • Try ejecting and reinserting the cassette. • The cassette tape might be broken, try another cassette. • You might have reached the end of the cassette, try rewinding it.
Won't playback	<ul style="list-style-type: none"> • <i>POWER</i> switch must be set to <i>VCR</i> position.
Won't record	<ul style="list-style-type: none"> • Safety tab removed or closed. (See page 22.) • <i>POWER</i> switch must be set to <i>CAMERA</i>.
No picture	<ul style="list-style-type: none"> • Open lens cover.
Camcorder turns itself off	<ul style="list-style-type: none"> • Set <i>POWER</i> switch to <i>OFF</i> and then to <i>CAMERA</i> or <i>VCR</i> to turn back on. If camcorder is left in record-pause or play-pause for several minutes, it turns off to prevent tape wear.

Trouble Checks

Trouble	Checks and Adjustments
Tape stops during rewind or fast forward	<ul style="list-style-type: none"> • Time-counter memory might be on. Whenever an "M" appears with the time-counter display, the camcorder stops rewinding (or fast forwarding) when counter reads <i>M 0:00:00</i>. Press <i>VCR ◀◀</i> or <i>VCR ▶▶</i> again to continue rewinding or fast forwarding, or press <i>COUNTER R/M</i> to turn off the memory-stop feature.
Camcorder remains in pause mode	<ul style="list-style-type: none"> • Press <i>PLAY/PAUSE</i> to return to normal playback.
Dew indicator flashes in viewfinder	<ul style="list-style-type: none"> • If the dew indicator () flashes in the viewfinder, there is moisture in the camcorder. Wait until indicator no longer appears before operating the camcorder.
Poor auto-focus operation	<ul style="list-style-type: none"> • Subject is dark or behind glass. Auto-focus may not work under these conditions. Rotate <i>AE</i> dial to <i>MAN</i> and focus manually. <i>See pages 36-37.</i> • Subject is not in center of viewfinder or two subjects are at different distances. Rotate <i>AE</i> dial to <i>MAN</i> and focus manually. <i>See pages 36-37.</i> • Lens is smudged, and image appears unfocused.
Viewfinder displays are out of focus	<ul style="list-style-type: none"> • Lens is smudged and image appears unfocused. • Eyepiece focus control is misadjusted. • The small <i>C</i> (color) and <i>B</i> (brightness) controls on the bottom of the viewfinder control the color and brightness of the viewfinder. These controls are set at the factory and should require no adjustment. If the color or brightness every does need adjustment, carefully use a plastic screwdriver and make the adjustments with caution to prevent damaging the miniature controls.
Picture is too dark or subject too dark	<ul style="list-style-type: none"> • For best results, only use higher shutter speeds outdoors. Rotate <i>AE</i> dial to sports () or <i>1/1000</i>. <i>See page 43.</i> • Subject in front of a strong backlight. Rotate <i>AE</i> dial to select back lit () or press <i>BACKLIGHT</i> button. <i>See pages 43-44.</i> • Subject in front of a strong frontlight. Rotate <i>AE</i> dial to select front lit () or press <i>FRONTLIGHT</i> button. <i>See pages 43-44.</i> • Rotate <i>AE</i> dial to <i>MAN</i> and adjust exposure manually. <i>See pages 40-41.</i> • Model CC6271 Only: Turn on built-in light.

Trouble Checks

Trouble	Checks and Adjustments
Sound is too low or distorted	<ul style="list-style-type: none"> • Subject was too far from camcorder.
Picture recorded with special effect	<ul style="list-style-type: none"> • <i>AE</i> dial might be turned to special effect mode. Rotate the <i>AE</i> dial to <i>AUTO</i>. See page 43.
Colors do not look natural on recording	<ul style="list-style-type: none"> • Try adjusting white balance. See pages 38-39.
Title recorded on tape	<ul style="list-style-type: none"> • Title is recorded when it appears in viewfinder. Remove the title. See pages 20-21 and 46.
Date and/or time are recorded on tape	<ul style="list-style-type: none"> • Displays are recorded on tape whenever they appear in the viewfinder. Remove them from viewfinder when recording. See pages 20-21. • When <i>AUTO DATE</i> is selected (<i>AE</i> dial in <i>AUTO</i>), date display is automatically recorded when you begin recording or change the cassette. See pages 20-21.
Date and/or time are incorrect	<ul style="list-style-type: none"> • Clock lithium cell battery might need replacing. See page 17. • Date or time might need to be set. See pages 18-19.
Cannot set <i>REC</i> or <i>INT. TIME</i> for animation or time-lapse recording	<ul style="list-style-type: none"> • Make sure there is a tape in the camcorder. • Check tape speed setting. Tape speed must be set to <i>SP</i> for time-lapse or animation recording. • Make sure <i>AE</i> dial is not set to <i>AUTO</i> to display <i>MENU</i>. See pages 50-53.
Tally light does not light during recording	<ul style="list-style-type: none"> • <i>TALLY LAMP</i> feature set to <i>OFF</i> in the <i>TALLY LAMP</i> menu. See page 54.
Vertical white lines appear when shooting bright object	<ul style="list-style-type: none"> • This might occur when the background extremely contrasts with the subject.
Error number (<i>E01</i> , <i>E02</i> , etc.) appears in viewfinder	<ul style="list-style-type: none"> • Try disconnecting power source. Wait ten seconds and then connect power source again. If error number does not disappear from viewfinder, consult your Authorized RCA Camcorder Service Center.

Trouble Checks

Trouble	Checks and Adjustments
Model CC6271: light turns on and off	<ul style="list-style-type: none"> • Lighting condition changes frequently. Set <i>LIGHT AUTO•OFF•ON</i> light switch to <i>ON</i> or <i>OFF</i>.
Streaks in picture during playback or play-pause	<ul style="list-style-type: none"> • Adjust tracking with <i>MENU</i> dial. See page 61.
Bright, crystal-shaped spots in viewfinder	<ul style="list-style-type: none"> • Sunlight is directly entering the lens.
Colored bright spots appear in viewfinder	<ul style="list-style-type: none"> • Models CC6251 and CC6271: Black spots or bright spots of light (red, green, or blue) may appear. These spots are not recorded on the tape and are not due to a defect.
Rechargeable battery runs down sooner than expected	<ul style="list-style-type: none"> • If battery has not been used for some time, completely drain the battery's power and recharge it. • Battery run times are measured when the camcorder is recording continuously. You can check your battery by first fully charging it and then aiming the camcorder at a clock and recording the picture of the clock. When the recording stops, play the last recorded section and note the clock time. A one-hour battery should give you about 60 minutes of recording time. In practical use, you might not be able to record for the full time because the camera uses battery power when it is waiting between recordings (record-pause) and zooming.

Care and Maintenance

Clean the Camcorder

To clean the camcorder's exterior, remove any power source connected to the camcorder and gently wipe it with a clean soft cloth.

Caution: Use of strong cleaning products, such as those containing alcohol or benzine, might damage the camcorder.

Clean the Camcorder's Lens

To clean the camcorder's lens, blow it with a blower brush and gently wipe the lens with cleaning tissue and commercially prepared cleaning solution designed for use on camera lens. Improper cleaning might scratch the lens.

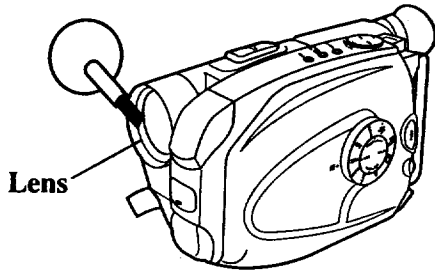

Caution: Do not touch the lens with your fingers. The oil from your skin might damage the lens.

Clean the Camcorder's Viewfinder

You can remove the viewfinder eyepiece for cleaning.

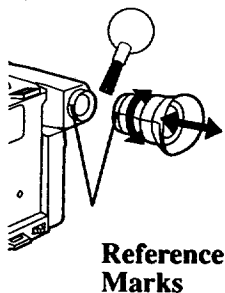

1. Turn the eyepiece counterclockwise and pull it out.
2. Remove dust using a blower brush.
3. Reattach the eyepiece by aligning the reference marks, and then turn the eyepiece clockwise until it clicks.

Proper Care and Storage

- Keep dust and grit from entering the camcorder's cassette door. Dust and grit are abrasive and cause excessive wear to both the camcorder's recording/playback heads and cassettes.
- Always close the lens cover when the camcorder is not in use.
- Before handling your camcorder, make sure your hands and face are free from any chemical products such as suntan lotion, as it might damage the finish.
- The camcorder might be damaged by improper storage or handling. Do not subject the camcorder to swinging, shaking, or dropping.
- Do not store the camcorder in temperatures below -22°F (-30°C) or above 149°F (65°C).
- When the camcorder is not in use, always remove the cassette and AC adapter/charger or battery.
- Retain the original carton for future storage or shipping purposes.

Things to Avoid

- Do not attempt to disassemble your camcorder. There are no user-serviceable parts inside.
- Avoid operating your camcorder immediately after moving it from a cold location to a warm location. Give the camcorder 1-1/2 to 2 hours to reach a stable temperature before inserting a cassette. When the camcorder is moved from cold to warm, condensation might cause the tape to stick to the headwheel and damage the headwheel or tape.
- Do not aim your camcorder at the sun or other bright objects.
- Do not leave your camcorder in direct sunlight for extended periods of time. The resulting heat buildup might permanently damage the camcorder's internal parts.
- Do not operate the camcorder in extremely humid environments.
- Do not operate the camcorder near the ocean as salt water or salt water spray might damage the internal parts of the camcorder.
- Do not operate the camcorder for extended periods in temperatures below 40°F (4°C) or above 95°F (35°C).
- Do not expose the camcorder or adapter/charger to rain or moisture. If any component becomes wet, turn off the power and take the unit to an Authorized RCA Camcorder Service Center.
- Do not use an adapter/charger or batteries other than the ones specified for the camcorder. Use of the wrong accessories might cause damage to the camcorder.

Specifications

General

Power requirement: 6VDC

Power consumption:

CC6151: 5.0 watts

CC6251: 5.1 watts

CC6271(normal): 5.1watts

CC6271 (light on): 8.0 watts

Weight: CC6151: 1.8 lbs. (800g)

CC6251: 1.8 lbs. (780g)

CC6271: 1.8 lbs. (790g)

Dimensions – Including Viewfinder:

Models 6251 and 6271

4-1/2" (W) x 4-5/8" (H) x 8-3/4" (D)

114 (W) x 117 (H) x 222 (D) mm

Model 6151

4-1/2" (W) x 4-5/8" (H) x 9-9/16" (D)

114 (W) x 117 (H) x 242 (D) mm

Video Recorder Section

Format: VHS-C

Record/playback system:

Four video record/playback heads

One flying erase head

Video signal: EIA standard

NTSC color

Viewfinder

Models 6251 and 6271

.55" Color viewfinder

Model 6151

0.5" Black-and-white electronic viewfinder

Camera Section

Image sensor: 1/4" CCD imager

Lens: F1.6, f=3.8 to 83.6mm

22:1 power zoom lens

Filter diameter: 46 mm

Tripod Mount

One 1/4" x 20 threaded hole

AC Adapter/Charger

Power requirement: 100-240 V,
50/60 Hz.

Power consumption: 23 watts

Weight: .71 lbs. (300g)

Dimensions:

5-9/16"(W) x 1-11/16"(H) x 2-11/16"(D)

140 (W) x 42 (H) x 68 (D) mm

Information to User

This equipment has been tested and found to comply with the limits for a Class B digital device pursuant to Part 15 of the FCC Rules. These limits are designed to provide reasonable protection against harmful interference in a residential installation. This equipment generates, uses, and can radiate radio frequency energy and, if not installed and used in accordance with the instructions, may cause harmful interference to radio communications. However, there is no guarantee that interference will not occur in a particular installation. If this equipment does cause harmful interference to radio or television reception, which can be determined by turning the equipment off and on, the user is encouraged to try to correct the interference by one or more of the following measures:

- Reorient or relocate the receiving antenna.

- Increase the separation between the equipment and receiver.
- Connect the equipment into an outlet on a circuit different from that to which the receiver is connected.
- Consult the dealer or an experienced radio/TV technician for help.

Alterations or modifications carried out without appropriate authorization may invalidate the user's FCC right to operate the equipment.

This Class B digital apparatus meets all requirements of the Canadian Interference-Causing Equipment Regulations.
Cet appareil numérique de la classe B respecte toutes les exigences du Règlement sur le matériel brouilleur du Canada.

Customer Assistance and Service

You can reach Thomson at the following number:

800-283-6503

(Toll free inside U.S.A.)

Our toll-free Camcorder number operates from 8 a.m. to 5 p.m., CST Monday – Friday for U.S. customers only

Thomson provides a toll-free telephone number to help you with any problems you may encounter with your camcorder. Many can be diagnosed over the phone, and if necessary, repair or replacement will be arranged. Please have your camcorder model/serial number and date of purchase ready when you call. If your unit is out of warranty, we will quote the cost of a repair or replacement unit to you.

Returning equipment to Thomson for repair or exchange

If we are unable to resolve your problem over the phone, we will gladly service your unit or exchange it for a new or refurbished camcorder. Refer to the limited warranty on the reverse side to learn about your specific rights and responsibilities.

Always consult Thomson and get a Return Authorization number before returning anything! Obtain a Return Authorization (RA) number from the telephone representative before returning your equipment to avoid delays, accounting errors, or even loss of your unit.

Important information to customers who ship defective equipment to Thomson Consumer Electronics

The Thomson representative who authorized the return of your equipment will give you an RA number over the phone. They will also provide you with instructions on where and how to return your Camcorder. Write the number in large, clear characters on the outside of the box. To avoid confusion and misunderstandings, shipments without an RA number clearly visible on the outside of the box will be returned to you at your expense.

Include a brief note describing the problem and any conversations about the problem you have had with Thomson personnel.

Include your name, address and model/serial number of your Camcorder. These numbers

are located on the bottom of your unit.

If your Camcorder is within the warranty period, please provide a copy of the bill of sale to verify purchase date. Use the original box and packing material to protect the equipment from damage in shipment.

For your protection, insure all shipments for full replacement value and use a reliable shipper. Thomson assumes no responsibility for warranty shipments from the customer to the factory if not shipped in the manner prescribed by Thomson.

Limited Warranty

What your warranty covers:

- Any defect in materials or workmanship.

For how long after your purchase:

- 90 days for labor charges.
- One year for parts.

The warranty period for rental units begins with the first rental or 45 days from date of shipment to the rental firm, whichever comes first.

What we will do:

During the initial 90 days

- Exchange your camcorder with a new or refurbished unit, or repair your camcorder. The option will be ours. There will be no cost to you.

After the 90 days and within one year

- Exchange your camcorder with a new or refurbished unit, or repair your camcorder. The option will be ours. Parts will be provided at no charge, but you will be responsible for the cost of labor required for the repair.

How you get service:

- Call 1-800-283-6503 and have your unit's date of purchase and model/serial number ready. The model/serial number information is on the bottom of your camcorder.
- A representative will troubleshoot your problem over the phone. If the representative determines that you should receive a replacement unit, you will be provided with a Return Authorization (RA) number and the location of a nearby exchange point if one exists. No returns will be accepted without the RA number.

To receive a replacement Camcorder before you return yours:

If you are located near an exchange point:

1. We will send a replacement unit to the exchange point next business day delivery in the continental U.S.A.

2. The exchange location will notify you of its arrival.
3. Take your unit, excluding all accessories, and your evidence of purchase date, such as a bill of sale, to the exchange location and you will be provided the new or refurbished unit.
4. If the repairs were covered by your warranty, you will not be billed.

If you are *not* located near an exchange point:

1. Provide your Discover, MasterCard, or Visa account number and expiration date to our phone representative. This is for security purposes. If we receive your unit, excluding all accessories, within 14 days from the date you were provided the RA number, only items not covered by warranty will be charged to your account. **IF YOUR UNIT IS NOT RECEIVED WITHIN 14 DAYS, THE SUGGESTED RETAIL VALUE OF THE CAMCORDER WILL BE CHARGED TO YOUR CREDIT CARD.** This amount will be credited if the unit is subsequently received.
2. We will send you a replacement unit next business day delivery in the continental U.S.A.
3. You will receive an invoice packed with the replacement product, but will not be charged for the unit portion of the invoice amount if we receive your unit within 14 days from the date you were provided the RA number. Any labor and parts charges not covered by our warranty will be included and charged against your account.
4. Ship the unit back to us, excluding all accessories, using the replacement unit's carton. Shipping instructions will be included in the carton along with your RA number which will allow you to easily ship the unit back to us. **Make sure you insure your shipment in case of damage or loss.** Include with the shipment:

Limited Warranty

- Evidence of purchase date, such as a bill of sale, to verify your unit's warranty eligibility.
- A brief note describing your camcorder's problem.
- Your name, address and phone number.

Return transportation, storage, handling, and insurance costs are your sole responsibility. We accept no liability in case of damage or loss.

To receive a replacement unit after we have received your unit:

1. **Write the RA number on the outside of the carton used to return the unit. Make sure you insure your shipment in case of damage or loss.**
2. Carefully pack the unit, excluding all accessories, using the original box and packing material if possible.
3. Include with the shipment:
 - Evidence of purchase date, such as a bill of sale, to verify your unit's warranty eligibility.
 - A brief note describing your camcorder problem.
 - Your name, address and phone number.

Return transportation, storage, handling, and insurance costs are your responsibility. We accept no liability in case of damage or loss.

4. The representative will advise the address to mail a cashier's check or money order for payment if there are any out of warranty labor or parts charges and you elect not to use your credit card.
5. Upon receipt of your product, a new or refurbished unit will be shipped to you next business day delivery in the continental U.S.A.

To have your Camcorder repaired by an Authorized RCA Camcorder Service Center:

- Check with your dealer or call 1-800-336-1900 for the Authorized RCA Camcorder Service Center nearest you.

- Take your unit to the Authorized RCA Camcorder Service Center of your choice.
- Show the Authorized RCA Camcorder Service Center representative evidence of purchase date, such as a bill of sale.
- Pick up your camcorder when repairs are complete.

What your warranty does not cover:

- Adjustment of customer controls.
- Damage from misuse or neglect.
- A unit that has been modified or incorporated into other products or is used for institutional or other commercial purposes.
- Batteries for remote control and clock.
- Cleaning of video/audio heads.
- Camcorders purchased or serviced outside the U.S.A.
- Return transportation, storage and handling costs of your unit, including insurance for loss or damage.
- Acts of God, such as but not limited to lightning damage.

Product Registration:

- Please complete and mail the Product Registration Card packed with your camcorder. It will make it easier to contact you should it ever be necessary. The return of the card is not required for warranty coverage.

How State Law relates to warranty:

- This warranty gives you specific legal rights and you also may have other rights that vary from state to state.

If you purchased your camcorder outside the United States:

- This warranty does not apply. Contact your dealer for warranty information.

Index

I S 1/1000 indicator 28, 43

A

Accessories

- included 3
- optional 70
- order form 73

Accessory order form 73

Adapter/charger

- charging battery 14
- using 4, 12

AE dial

- 7, 8, 10, 18, 20, 21, 24, 32, 34, 35, 36, 38, 40, 43, 44, 46, 47, 48, 50, 52, 54, 55, 56

indicators 28, 43

features 43

Animation indicator 31, 51

Animation recording 50

Assistance 1, 3, 83

Attach shoulder strap, 57

Audio/video jacks 11, 66, 68

Auto date display 20, 32

Auto date feature 20, 32

Auto exposure 40

Auto focus 36

Auto head cleaner 33

AUTO indicator 28

AUTO mode 8, 32

Auto white balance 38

Automatic head-cleaning system 22

B

B (bright) control

- (models CC6251 and CC6271) 11, 77

BACK LIT indicator 43, 44

Back-lit feature 43, 44

BACKLIGHT button 44

BATT. (battery) RELEASE button 11, 13

Battery

- attaching and removing 13
- care and storage 15
- charging 14
- level indicator 15, 29
- refreshing 14
- using 13

Battery, installing in cassette adapter 64

Built-in light

- (model CC6271) 58

Bulb for light, replacing

- (model CC6271) 59

C

C (color) control

- (models CC6251 and CC6271) 11, 77

Cable TV installer note 69

Camcorder, cleaning 80

Camcorder's operating controls 10

Camera edit feature 33

Car cord adapter 16

Care and maintenance

- clean the camcorder 80
- clean the camcorder's lens 80
- clean the camcorder's viewfinder 80
- proper care and storage 81
- things to avoid 81

Care and storage

- battery 15
- camcorder 81
- cassette 23

Cassette adapter 64

Cassette care and storage 23

Cassette compartment 11

Cassette warning 29

Cassettes

- inserting and removing 23

Cassette's tape wheel 5, 23

Cautions i

CHARACTER menu 47

Checks and adjustments 76

Clean the camcorder 80

Clean the camcorder's lens 80

Clean the camcorder's viewfinder 80

Clock cell battery compartment 11, 17

Clock cell indicator 17, 31

Color enhancement light

- (model CC6271) 10, 58

Contents 1

Copy tapes 67

COUNTER R/M button 10, 63, 67

Customer assistance and service 83

Index

D

Date and time displays
 setting 18
Date, time, and title displays
 recording 20
DATE/TIME button 10, 20, 21, 29, 47
DATE/TIME menu 18
DC cable 12, 13, 14, 16
DC in jack 4, 12
Demo mode 55
DEMO MODE menu 55
Design specifications 82
Dew warning 30, 77
Displays, status 29

E

EJECT button 5, 11, 23, 60
Erase protection 22
Exposure control 40, 41
Exposure indicator 41, 44
EXPOSURE menu 41
Eyepiece focus control 6, 11, 27, 60

F

Fade/wipe feature 42
First time operation 3
Flying erase head 33
Focus indicators 30, 37
FOCUS menu 37
Focusing 36
FRONT LIT indicator 43, 44
FRONTLIGHT button 44
Full auto feature 32

H

Handstrap 4, 11
Head cleaning 22, 33
HZ:HAZE indicator 28, 43

I

Indicators
 1 S 1/1000 43
 AE dial 28, 43
 animation 31, 51
 AUTO 28, 43

AUTO RELEASE 43
BACK LIT 28, 43, 44
battery level 15
cassette warning 29
clock cell 17, 31
date display 29
exposure 30, 41, 44
focus 30, 37
FRONT LIT 28, 43, 44
HAZE 28
HZ:HAZE 43
interval time 49, 53
LENS COVER 31
MAN 28
manual white balance 29
MWB 39
record time 51, 53
REFRESH 14
S 1/1000 28
SD:SHADOW 28, 43
self-timer 31
SEPIA 28, 43
SPORTS 28, 43
TAPE END 25, 31
tape length 31
tape speed 31
time counter 31
time display 29
time lapse 31, 53
time remaining 25, 31
title display 29
tracking 29
white balance 39
zoom level 29, 34
Information to user 82
Inserting and removing cassettes 23
INT. TIME menu 49, 52
Interval indicators 49, 53

J

JLIP (joint level interface protocol)
 identification number 56
JLIP connector 11, 56
JLIP ID no. 56
JLIP ID NO. menu 56

Index

L

Lens 10
Lens cover 4
LENS COVER control 4, 11
LENS COVER indicator 31
Light, color enhancement
(model CC6271) 58, 59
LIGHT OFF•AUTO•ON switch
(model CC6271) 11, 58
Limited warranty 84
Lithium cell
inserting and removing 17
Lithium cell indicator 17, 31
Low-contrast indicator 36

M

M.W.B. menu 39
Main MENU
18, 24, 29, 35, 36, 38, 41, 47,
48, 50, 52, 54, 55, 56
MAN indicator 28
Manual exposure 40
Manual white balance 38
Memory stop 63
MENU dial 7, 11, 18, 19, 24, 32, 34, 35,
36, 38, 41, 47, 48, 49, 50, 51, 52,
53, 54, 55, 56, 61
Microphone 10, 32
MWB indicator 39

O

Operating controls 10
Optional accessories 70
Optional plug adapter 12
Order form, accessories 73

P

Pause indicator 5, 8
Pause, stop-action 62
PLAY/PAUSE button 9, 10, 61, 62, 67, 69
Playback
first 9
on a TV without audio/video inputs 68
on TV (or VCR) with audio/video
inputs 66
using cassette adapter 64
viewfinder 60

Playback features
memory-stop 63
position the tape 62
stop-action pause 62
time counter 63
tracking 61
visual searching 62
Playback on a TV without audio/video
inputs 68
Playback on TV (or VCR) with
audio/video in jacks 66
Playback speeds 22
Plug adapter, optional 12
Power indicator 5, 11, 16
POWER switch
5, 9, 11, 13, 15, 16, 18, 20, 24, 29,
32, 33, 35, 36, 38, 40, 42, 58, 60,
62, 63, 67, 69

Powering your camcorder
using adapter/charger 12
using battery 13
using optional car cord adapter 16
Preset title, recording 46
Problem solving 76
Product registration i
PUSH button 5, 11, 23, 60

Q

QUICK REC button 10, 33
Quick record feature 33
Quick review feature 33

R

RBRC seal 13
REC TIME menu 51, 53
Record indicator 8, 29
Record time indicators 31, 49, 51
Recording
animation 50
first time 3
self timer 48
time lapse 52, 53
titles 20, 46
Recording speeds 6, 22
REFRESH button 14
REFRESH indicator 14
Registration i
RF DC OUT jack 11, 68

Index

RF output adapter, optional 68

S

Safety information i

Safety precautions, battery 13

Safety tab 22

SD:SHADOW indicator 28, 43

Second MENU 47, 49, 51, 52, 53, 54, 55, 56

Self timer 48, 49

Self timer indicator 31, 49

SEPIA indicator 28, 43

Setting tape length 7

Shoulder strap, attach 57

Shoulder strap attachment rings 11, 57

Shutter speed indicator 43

SLP recording speed 6

SLP tape speed 6, 22

Solving problems 76

SP recording speed 6, 22

SP tape speed 6, 22

SP/SLP button 22, 24, 50, 52

Specifications 82

Speeds, recording and playback 22

Sports feature 43

SPORTS indicator 28, 43

Status displays 29

STOP button 9, 10, 61, 62, 63, 67, 69

Stop-action pause 62

T

Table of contents 1

Tally lamp feature 33, 54

TALLY LAMP menu 54

Tally light 8, 10, 32, 33, 49

Tally light feature 33, 54

Tape copying 67

TAPE END indicator 25, 31

Tape, inserting 5

Tape length feature 24

Tape length indicators 25, 31

TAPE LENGTH menu 7, 25

Tape length, set 7, 24

Tape wheel 5, 23

Tele macro feature 35

TELE MACRO menu 35

Tele macro zooming 35

Things to avoid 81

Thumb trigger 11, 32, 33, 49, 51, 53, 67

Time counter 31, 63

Time display: 20

Time-counter display 31, 63

Time-lapse indicator 31, 53

Time-lapse recording 52, 53

Time-remaining display 24, 25, 31

Time-remaining feature 24

Tips

recording 26

travel 45

TITLE button 29, 46, 47

Title display 20, 29, 46, 47

Titles

creating your own 47

recording preset 46

recording your own 20

Tracking 61

Tracking indicator 29, 61

Travel tips 45

Tripod, using 71

Trouble checks 76

U

Unpack camcorder and accessories 3

V

VCR buttons 9, 10, 33, 62, 63

Videocassettes 22

Viewfinder 6, 11, 27

adjust for viewing 27

eyepiece focus control 27

playback 60

Visual searching 62

W

Warranty, limited 84

White balance feature 38

White balance indicators 29, 39

Z

Zoom buttons 11, 34, 36, 38

Zoom level indicator 29, 34

Zoom speed feature 34

ZOOM SPEED menu 35

Zooming 34

 **THOMSON CONSUMER ELECTRONICS**
10330 N Meridian Street
Indianapolis, IN 46290

©1998 Thomson Consumer Electronics, Inc.
Trademark(s)[®] Registered
Marca(s) Registrada(s)
Printed in Japan
TQCOM 15331700

LYT0079-001A(VP)