

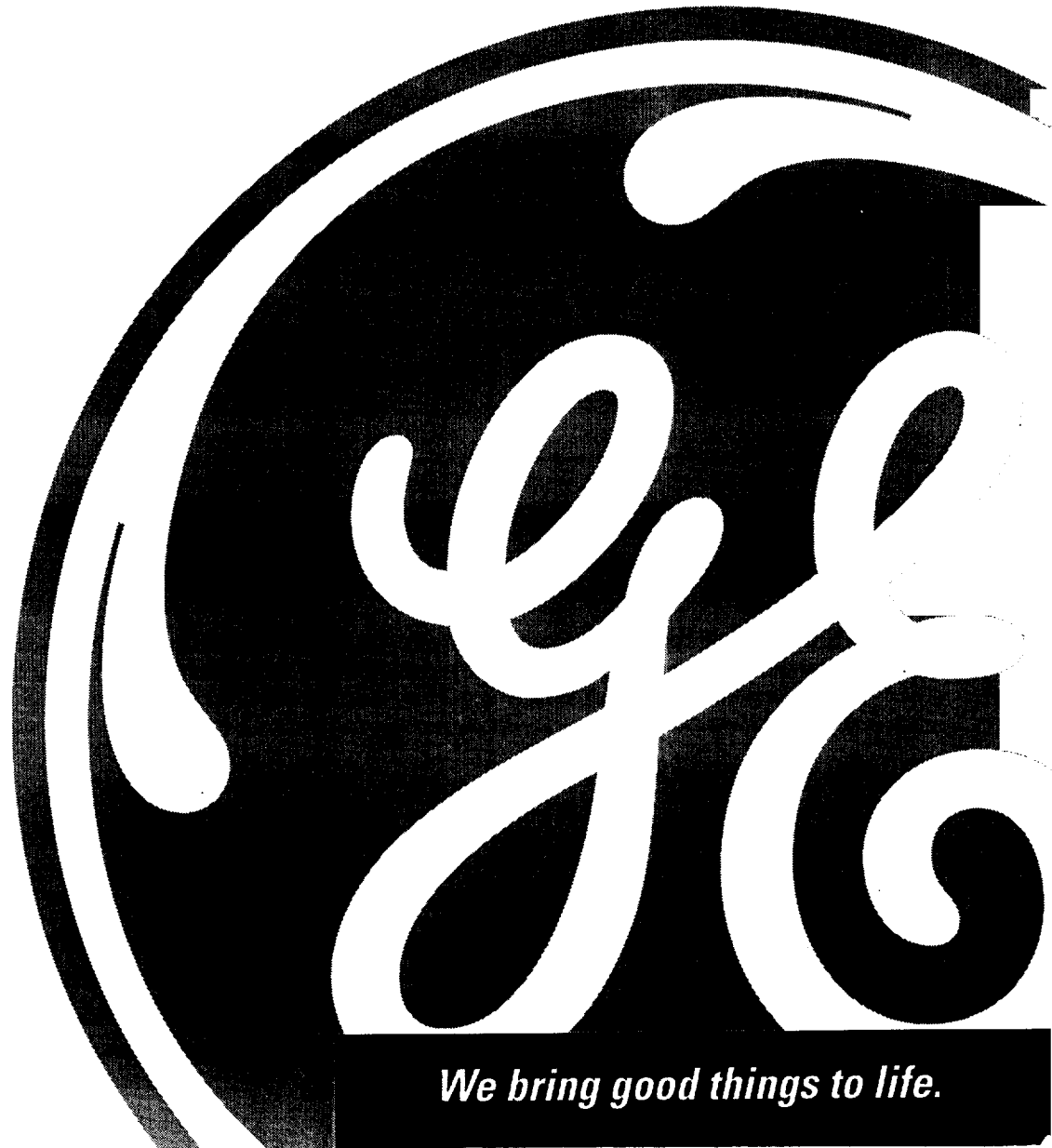

VG2042

VCR User's Guide



We bring good things to life.

IMPORTANT INFORMATION

WARNING

RISK OF ELECTRIC SHOCK
DO NOT OPEN

To reduce the risk of electric shock, do not remove cover (or back). No user serviceable parts inside. Refer servicing to qualified service personnel.



This symbol indicates "dangerous voltage" inside the product that presents a risk of electric shock or personal injury.



This symbol indicates important instructions accompanying the product.

WARNING

To reduce the risk of fire or shock hazard, do not expose this product to rain or moisture.

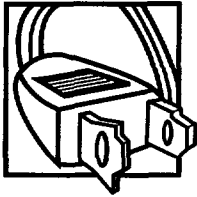

Caution: To reduce the risk of electric shock, match wide blade of plug to wide slot, fully insert.

Attention: Pour éviter les chocs électriques, introduire la lame la plus large de la fiche dans la borne correspondante de la prise et pousser jusqu'au fond.

Refer to the identification/rating label located on the back panel of your product for its proper operating voltage.

FCC Regulations state that unauthorized changes or modifications to this equipment may void the user's authority to operate it.

Cable TV Installer: This reminder is provided to call your attention to Article 820-40 of the National Electrical Code (Section 54 of the Canadian Electrical Code, Part 1) which provides guidelines for proper grounding and, in particular, specifies that the cable ground shall be connected to the grounding system of the building as close to the point of cable entry as practical.

Product Registration

Please fill out the product registration card and return it immediately. Returning this card allows us to contact you if needed.

Keep your sales receipt to obtain warranty parts and service and for proof of purchase. Attach it here and record the serial and model numbers in case you need them. The numbers are located on the back of the product.

Model No. **VG2042** _____

Serial No. _____

Purchase Date: _____

Dealer/Address/Phone: _____

TABLE OF CONTENTS

First Things First	3
Setting Up the VCR	8
Using the Menu to Set Up Features.....	8
Language	8
Cable Box Setup	8
VCR Channels List	10
To Auto Channel Search	10
To Change the Signal Type	11
To Add or Remove Channels	11
Time and Date	12
Set Daylight-Saving Time	12
Set the Time and Date	13
Additional Set-up Features in the PREFERENCES Menu ...	14
Remote VCR1/VCR2 Option	14
Auto Play	15
EnergySaver™	15
Tape Speed.....	16
VCR Basics	17
Remote Buttons	18
Component Buttons	18
VCR Function Buttons	18
TV Function Buttons	19
Playing a Tape	20
Automatic Rewind	21
Tape Eject	21
Recording	21
Check the Safety Tab	21
Recording	23
Recording Features	24
Express Recording.....	24
Timer Recording	25
Stopping a Timer Recording	26
Review and Clearing Programs	26
Using Two VCRs for Copying and Editing Tapes.....	27

TABLE OF CONTENTS

Programming the Remote...	29
About Programming the Remote	30
Programming the Remote to Control a TV	30
Programming the Remote to Control a Digital Satellite Receiver or Cable Box	32
Other Features	33
Picture Search Options	34
Forward and Reverse Search	34
Slow Motion	34
Commercial Scan (Search Button)	34
Frame Advance	35
Index Search	35
Zero Search	36
Pro-Tect Plus™ Locking Feature	36
Time Counter	37
On-Screen Displays	37
Tracking	38
Connections	39
Jacks and Cables	40
RF Jacks and Antenna Cables (F-type)	40
Audio/Video Jacks and Cables (RCA-type)	40
Choosing a VCR Connection	41
Advantages of Audio/Video Cable Connections	41
Don't Forget About the Auto TV/VCR Feature	41
TV With RF Jack Only	42
TV With Audio/Video Jacks	43
TV With Audio/Video Jacks and Cable Box to Unscramble Pay Channels Only	44
Reference	45
Front Panel	46
Back Panel	47
Indicator Panel	47
Troubleshooting Tips	48
Specifications	51
Cleaning the VCR	51
Limited Warranty	52
Index	53

FIRST THINGS FIRST

Hi, my name is Roger...

and I wrote this User's Guide. It's my job to see that you have a rewarding user manual experience. You'll find that I've arranged this manual to clearly explain all your VCR's features.

Read the First Three Sections

The first three sections of the manual introduce you to your VCR, and show you how to set the VCR up and use the on-screen menus. Reading these sections gives you the basic information you need to use your VCR.

What's Left?

The rest of the book highlights playback and recording information, contains a detailed connections section, and a reference section that includes troubleshooting tips, limited warranty, and index.

1 FIRST THINGS FIRST



2 SETTING UP THE VCR



3 VCR BASICS



4 RECORDING



5 PROGRAMMING THE REMOTE



6 OTHER FEATURES



7 CONNECTIONS

READ ME!

These note boxes give you tips for your new video cassette recorder.

FIRST THINGS FIRST

STEP 1: Unpack What's in the Box

The following items come packed in the box:

- VCR
- Remote control
- RF antenna cable

STEP 2: Install Batteries in the Remote Control

Follow these steps whenever you need to install or change the batteries in your VCR remote.

1. Remove the cover of the battery compartment.
2. Place batteries in remote, matching the + and – ends of each battery to the diagram inside the compartment.
3. Replace the cover.

STEP 3: Connect Your VCR

If you connect your VCR to your home antenna or cable system and then to your TV, use the VCR's IN FROM ANT. and OUT TO TV jacks for a good signal as shown.

If you have a TV with AUDIO/VIDEO jacks, use the audio/video jacks on the TV and VCR for a better connection. Refer to the *Connections* section, toward the back of the manual.

STEP 4: Plug in the VCR

Match the wide blade of the plug with the wide slot in the outlet. Be sure to insert the plug completely.

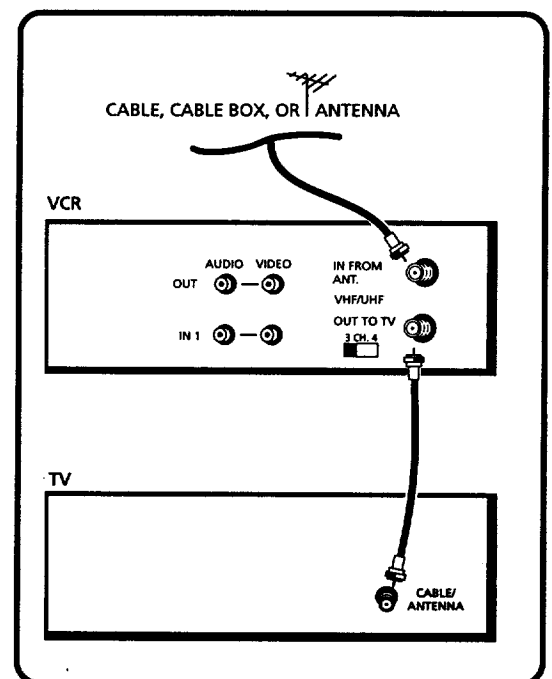

FIRST THINGS FIRST

STEP 5: Tune the TV

Tune the TV to the VCR viewing channel. The VCR viewing channel is channel 3 or 4 or the TV's video input.

- If you connect your VCR using the ANTENNA connectors with RF antenna cable, set the 3CH.4 switch to channel 3 or channel 4—the channel you want to use on your TV.
- If you connect your VCR using the AUDIO/VIDEO jacks with audio/video cables, select the TV's video input to see the signal. See the *TV Owner's Manual*.

STEP 6: Turn On the VCR

Press POWER to turn on the VCR. Turning on the VCR for the first time starts the Interactive Setup feature.

STEP 7: Interactive Setup

The first time the VCR is turned on, Interactive Setup—a brief series of on-screen menus—appears. These menus assist in setting up several of the VCR's features. Use the remote's number buttons to select options.

1. Press 1 for English, 2 for Español (Spanish), or 3 for Français (French).

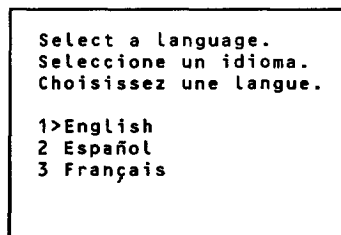

The remaining Interactive Setup menus will appear in the language you choose. Follow the on-screen instructions to complete the process.

VCR Viewing Channel

When using the ANTENNA jacks to connect your VCR, tune your TV to channel 3 or 4.

When using the audio/video jacks to connect your VCR, tune your TV to the TV's video input channel.

FIRST THINGS FIRST

STEP 8: Access the Menus

When you've completed Interactive Setup, try out the VCR's regular on-screen menus. The MENU and number buttons let you access, select, and change menu items. For example, to change the Auto Play setting, you would do the following:

1. Press MENU to bring up the VCR MAIN MENU.

```
VCR MAIN MENU
1 Timer Recordings
2 Time
3 Channels
4 Preferences
5 Language

0 Exit
```

2. Press 4 to display the PREFERENCES menu.

```
PREFERENCES
1 Remote Control: VCR1
2 Auto Play:      ON
3 EnergySaver:   2:00
4 Tape Speed:    SLP

0 Exit
```

3. Press 2 to switch Auto Play to ON or OFF.

```
PREFERENCES
1 Remote Control: VCR1
2 Auto Play:      OFF
3 EnergySaver:   2:00
4 Tape Speed:    SLP

0 Exit
```

See *Setting Up the VCR* for detailed information about the Auto Play feature. Once you understand how to use the menus, move on to the next section.

SETTING UP THE VCR

Set-up Features

Below is a list of set-up features that you may want to set up before you begin using your VCR for the first time:

- Select a language
- Set for use with a cable box
- Set up VCR channel list (Auto Channel Search)
- Set automatic daylight-saving time
- Set the time and date
- Set the Remote VCR1/VCR2 feature
- Set the Auto Play feature
- Set the EnergySaver™ feature
- Set the preferred Tape Speed

1 FIRST THINGS FIRST



2 SETTING UP THE VCR



3 VCR BASICS



4 RECORDING



5 PROGRAMMING THE REMOTE



6 OTHER FEATURES



7 CONNECTIONS

SETTING UP THE VCR

Using the Menu to Set Up Features

You can set up features by using the menu system. Each feature is explained in this section.

Language

Select your preferred language, and the on-screen displays will appear in that language.

1. Press MENU to display the VCR MAIN MENU.

```
VCR MAIN MENU
1 Timer Recordings
2 Time
3 Channels
4 Preferences
5 Language

0 Exit
```

- 2: Press 5 to display the LANGUAGE menu.

```
LANGUAGE
Select a language.
1>English
2 Espanol
3 Francais

Press MENU to continue
```

3. Press 1 for English, 2 for Español (Spanish), or 3 for Français (French).

Cable Box Setup

This setup applies only when all channels are received through the cable box. The VCR will automatically enter the output channel of the cable box when programming your VCR for timer recordings.

On-screen Menus

Not all the VCR screens are shown in this manual when explaining the features.

SETTING UP THE VCR

1. Press MENU to display the VCR MAIN MENU.

```
VCR MAIN MENU
1 Timer Recordings
2 Time
3 Channels
4 Preferences
5 Language

0 Exit
```

2. Press 3 to display the CHANNELS menu.

```
CHANNELS
1 Auto Channel Search
2 Add/Remove Channels
3 Signal Type: CABLE
4 Cable Box Setup

0 Exit
```

3. Press 4 to display CABLE BOX SETUP. Then select one of the three choices.

```
CABLE BOX SETUP
Do you use your cable
box to receive ALL
channels or only SOME
channels.

1 ALL channels
2 Only SOME channels
3 Cancel setup
```

4. If you select ALL CHANNELS, enter the output channel of your cable box, usually 03, 04, or video line input and press MENU.

```
CABLE BOX SETUP
On what channel does
the VCR receive signals
from the cable box?
(usually 3, 4, or Video)

04

Press CLEAR to correct
Press MENU to continue
```

```
CABLE BOX SETUP
The VCR will now
receive all signals
from the cable box
on channel 04.

Press MENU to continue
```

Once you complete the setup, the VCR confirms that Cable Box Setup is complete.

Cable Box Setup

ALL CHANNELS: enter two numbers for output channel of your cable box or press INPUT.

ONLY SOME CHANNELS: If you only use the cable box to tune premium channels.

CANCEL SETUP: select to cancel.

All Channels

If you do not use a cable box for **ALL** channels, then you will want to use a channel list (Auto Channel Search).

SETTING UP THE VCR

VCR Channels List

If you use a cable box for *all channels*, this step is not necessary. Your VCR may come with a channel list preset at the factory. Even though your VCR may come with a list, it's possible that you may want to add or eliminate some channels depending on whether they are active.

To Auto Channel Search

1. Press MENU to display the VCR MAIN MENU.

```
VCR MAIN MENU
1 Timer Recordings
2 Time
3 Channels
4 Preferences
5 Language

0 Exit
```

2. Press 3 to display the CHANNELS menu.

```
CHANNELS
1 Auto Channel Search
2 Add/Remove Channels
3 Signal Type: CABLE
4 Cable Box Setup

0 Exit
```

3. Press 1 to display the AUTO CHANNEL SEARCH menu.

```
AUTO CHANNEL SEARCH
What type of signal
are you using?
1 Cable TV
2 Antenna
3>Detect Automatically
0 Cancel
```

4. Select one of the three AUTO CHANNEL SEARCH options.

Choices one and two are self-explanatory. If you choose Detect Automatically, the VCR automatically detects which signal system you have attached to your VCR.

Detect Automatically

A strong cable or antenna signal in your area may cause Auto Detect to mis-detect. If this should happen, select 1 or 2 for the system you have.

Auto Channel Search

Use the Auto Channel Search feature to place all available channels in memory.

If you ever change cable or antenna signals, you may need to Auto Channel Search again.

SETTING UP THE VCR

```
AUTO CHANNEL SEARCH

Now scanning channel 14

Press any key to cancel
```

The VCR begins scanning for the available channels—this takes about one to two minutes. The lowest channel is tuned once the search is completed. Pressing CHANNEL up or down now selects the active channels.

To Change the Signal Type

1. Press MENU to display the VCR MAIN MENU.
2. Press 3 to display the CHANNELS menu.
3. Press 3 to change the Signal Type between CABLE and ANTENNA.

```
CHANNELS

1 Auto Channel Search
2 Add/Remove Channels
3 Signal Type:  CABLE
4 Cable Box Setup

0 Exit
```

To Add or Remove Channels

You may want to add or delete channels after you Auto Channel Search, especially if some of the channels have weak signals or you don't want to watch them.

1. Press MENU to display the VCR MAIN MENU.
2. Press 3 to display CHANNELS menu.
3. Press 2 to display the ADD/REMOVE CHANNELS menu. Use the CHANNEL up or down, or number buttons, to go to the channels you want to delete or add.

```
ADD/REMOVE CHANNELS

Channel 115
is presently ADDED

Press CLEAR to remove
Press MENU to exit
```

```
ADD/REMOVE CHANNELS

Channel 115
is presently REMOVED

Press INFO to add
Press MENU to exit
```

Selecting Channels

The CHANNEL up and down buttons access those channels active in your VCR channel list.

You can still access channels not in the channel list by using the number buttons on the remote control.

SETTING UP THE VCR

Time and Date

Before you set the time and date, set the Auto DST (Daylight Saving Time) feature to ON or OFF for your area.

Set Daylight-Saving Time

1. Press MENU to display the VCR MAIN MENU.

```
VCR MAIN MENU
1 Timer Recordings
2 Time
3 Channels
4 Preferences
5 Language

0 Exit
```

2. Press 2 to display TIME menu.

```
TIME
1 Set time and date
2 Auto DST: ON

0 EXIT
```

3. Press 2 to turn the Auto DST ON or OFF.
 - Select ON if you want the VCR's clock to automatically adjust for daylight-saving time.
 - Select OFF if you do not want the VCR's clock to adjust for daylight-saving time.

Spring forward; Fall backward

In the Spring, daylight-saving time begins on the first Sunday in April. Because the clock automatically changes from 2:00 AM to 3:00 AM (forward one hour), remember to include the extra hour for timer recording that falls within this time frame.

In the Autumn, daylight-saving time ends on the last Sunday in October. The VCR clock automatically changes from 2:00 AM to 1:00 AM (back one hour). Therefore, it can affect your recording length.

SETTING UP THE VCR

Set the Time and Date

1. Press MENU to display the VCR MAIN MENU.

```
VCR MAIN MENU
1 Timer Recordings
2 Time
3 Channels
4 Preferences
5 Language

0 Exit
```

2. Press 2 to display TIME menu.

```
TIME
1 Set time and date
2 Auto DST: ON

0 EXIT
```

3. Press 1 to display the SETTIME AND DATE screen.

```
SET TIME AND DATE
Time --:--
(hh:mm)
Date --/--/--
Press MENU to cancel
```

4. Enter the data using the number buttons. Press 0 before single-digit numbers and follow the on-screen directions.

```
SET TIME AND DATE
Time 12:34 PM
Date 10/24/97 Friday
Press CLEAR to correct
Press MENU to set
```

Time and Date

The time and date must be set before a timer recording can be programmed.

Time/Date Display

Pressing INFO on the remote displays the time and date on the TV screen.

SETTING UP THE VCR

Additional Set-up Features in the PREFERENCES Menu

The features in this section are all accessed through the PREFERENCES menu.

1. Press MENU to display the VCR MAIN MENU.

```
VCR MAIN MENU
1 Timer Recordings
2 Time
3 Channels
4 Preferences
5 Language

0 Exit
```

2. Press 4 to display PREFERENCES menu.

```
PREFERENCES
1 Remote Control: VCR1
2 Auto Play: ON
3 EnergySaver: 2:00
4 Tape Speed: SLP

0 Exit
```

Now you are ready to select an item from the menu to set up.

Remote VCR1/VCR2 Option

If you own a compatible GE, RCA or ProScan remote that has a VCR2, VCR2•LD, or DVD•VCR2 button, this feature allows you to set this VCR to respond to that button.

Press 1 to select the Remote Control item in the menu. Then press the VCR2, VCR2•LD, or DVD•VCR2 button to change.

```
PREFERENCES
1 Remote Control: VCR1
2 Auto Play: ON
3 EnergySaver: 2:00
4 Tape Speed: SLP

0 Exit
```

```
PREFERENCES
(PRESS VCR2 TO CHANGE)
2 Auto Play: ON
3 EnergySaver: 2:00
4 Tape Speed: SLP

0 Exit
```

Remote Control Option

Changing the Remote Control option to VCR2 disables the remote that came with your VCR.

SETTING UP THE VCR

The VCR will only respond to the compatible remote's VCR2, VCR2•LD, or DVD•VCR2 button. If you change the remote setting to VCR2, the remote that came with your VCR will no longer control the VCR.

Use the compatible remote to change the remote setting back to VCR1. Display the PREFERENCES menu, press 1, and then press VCR1. Then the remote that came with the VCR will be able to control it again.

Auto Play

This feature allows the VCR to automatically start playing when you insert a tape with the safety tab removed. Press 2 to switch between ON or OFF.

- Select ON if you want a tape with its safety tab removed to start playing automatically when the tape is inserted.
- Select OFF if you *do not* want a tape with its safety tab removed to start playing automatically.

EnergySaver™

By default, this VCR automatically turns off after two hours of inactivity. Press 3 to change the time delay, or to disable the feature.

- OFF: The VCR will remain turned on until you shut it off.
- 1:00, 2:00, or 3:00: The VCR turns off after one, two, or three hours of inactivity.

Thirty seconds before shutting off, the VCR will warn you with a screen reading, "The VCR will turn off in 30 seconds. Press any key to cancel."

If you use the VCR's tuner instead of your TV to tune channels, you may want to turn this feature off.

TV•VCR Button

Pressing TV•VCR on the remote will still switch between the VCR and TV mode.

VCR mode: VCR indicator in the display panel lights.

TV mode: VCR indicator turns off.

SETTING UP THE VCR

Tape Speed

You can select a preferred tape speed for recording. The speed you select appears in the timer recording menu. The default factory setting is SLP. Press 4 to switch between SP and SLP.

When making a recording, you can override the preferred tape speed.

- Press the SPEED button on the remote.
- Set the tape speed in the timer.

Each time you turn on the VCR, the tape speed reverts to the one you have selected.

Tape Speeds

SP (Standard Play)

Gives the best quality recording, but fewer programs can be recorded on the tape.

LP (Long Play)

Your VCR is capable of playing back tapes recorded in LP. You cannot record in the LP speed.

SLP (Super Long Play)

Gives three times the recording time of tapes recorded in SP. Special effects such as pause, slow motion, picture search, and frame advance work well when you play back tapes recorded in this speed.

Cassette	Recording Time	
	SP	SLP
T-120	2Hr	6Hr
T-160	2Hr	8Hr
	40Min	

VCR BASICS

Learn the Basics to Get You Started

These VCR basics should be enough for you to begin enjoying your VCR. Learning the remote control functions, playing a recorded tape, and recording a program should do just that.

However, there are other features that enhance the enjoyment of your VCR, but they aren't necessary to get you started. If you want to learn more about your VCR, just keep reading.

1 FIRST THINGS FIRST



2 SETTING UP THE VCR



3 VCR BASICS



4 RECORDING



5 PROGRAMMING THE REMOTE



6 OTHER FEATURES



7 CONNECTIONS

VCR Basics tells you what you need to know in order to watch a movie or tape your favorite show.

VCR BASICS

Remote Buttons

The remote control is capable of controlling more than just your VCR, and if you have compatible GE, RCA, or ProScan components, you may be able to control them without even having to program the remote.

Component Buttons

POWER Turns off VCR when remote is set to control the VCR. Also turns some compatible components on and off.

SAT CABLE Turns on a compatible GE, RCA, or ProScan digital satellite receiver and sets the remote to control the receiver. Can be programmed to control different brands of digital satellite receivers. Used with the POWER button to turn on a compatible cable box (if programmed) and sets the remote to control the cable box.

TV Turns on a compatible GE, RCA, or ProScan TV and sets the remote to control the TV. Also used with the POWER button to turn on a different brand of TV (if programmed) and sets the remote to control the TV.

VCR Turns on a compatible GE, RCA, or ProScan VCR and sets the remote to control the VCR.

VCR Function Buttons

CHAN Up or Down Selects next higher or lower channel in the VCR's channel memory.

CLEAR Resets time counter to 0:00:00. Allows you to change entries when setting the clock or a timer recording.

F.ADV Lets you view one frame with each press of the button when tape is in pause.

FWD Fast forwards the tape when the VCR is stopped. Searches forward through a tape during playback. Starts slow motion during play-pause and increases slow-motion speed.

GO BACK Switches between two channels. Select one channel and then select another using the number buttons. Press GO BACK to switch between the two channels.

INFO Shows the status displays on the TV screen.

INPUT Selects between the line input and the VCR's tuner. Line input refers to the signal coming from the component connected to the AUDIO/VIDEO IN jacks on the back of the VCR.

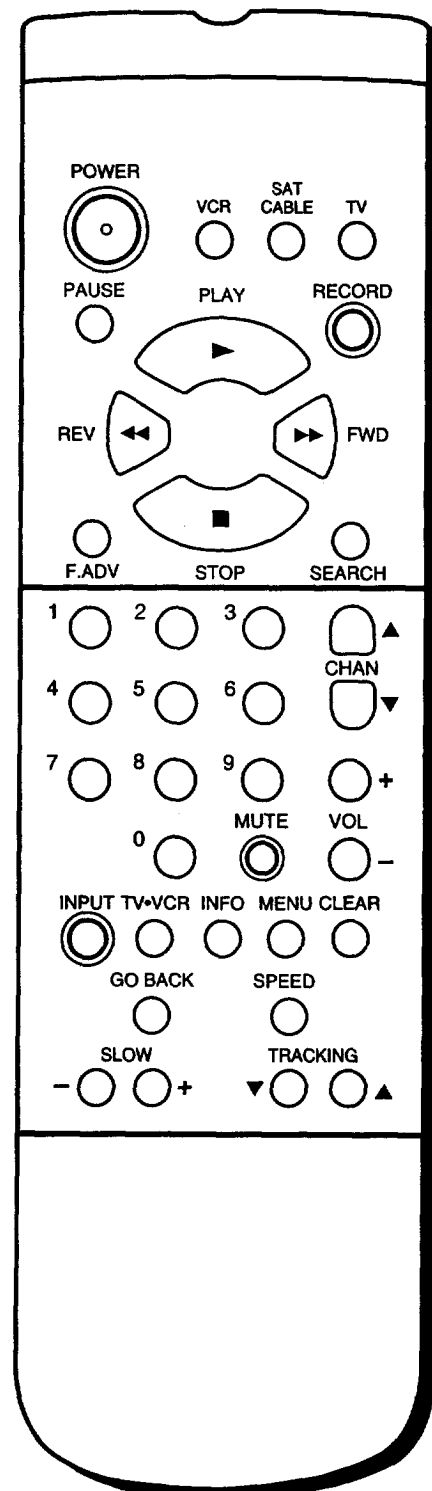

VCR BASICS

MENU Brings up VCR MAIN MENU on the TV screen.

Numbers (0 through 9) Select a channel up to 99 by pressing two numbers. Select a cable channel over 99 by pressing and holding 1 until 1 -- appears on the screen. Then press the other two numbers.

PAUSE Pauses playback or recording. Press PAUSE again to return to playback or recording.

PLAY Plays a tape.

POWER Turns the VCR off.

RECORD Starts VCR recording. Also used for express recording.

REV Rewinds the tape when the VCR is stopped. Searches backward through a tape during playback. Starts slow motion during play-pause and decreases slow-motion speed.

SEARCH Displays Index, Zero, and Blank Search menus on TV screen.

SLOW + and - Used for slow-motion playback. Press + to increase the speed or - to decrease the speed.

SPEED Selects a recording speed (SP or SLP).

STOP Stops the current VCR function such as record, playback, rewind, or fast forward.

TRACKING Up or Down Lets you manually reduce the streaks that may appear on the picture during play, slow motion, or pause. Reduces picture "jitter" during stop-action playback.

TV•VCR Switches the picture signal so that it either comes from the VCR or cable/antenna system.

TV Function Buttons

CHAN Up or Down Selects next higher or lower channel in the TV's channel memory.

CLEAR Removes menus or status displays from the screen.

GO BACK Switches between two channels. Select one channel and then select another using the number buttons. Press GO BACK to switch between the two channels.

INFO Shows the TV's status displays on the TV screen.

MUTE Reduces volume to minimum level.

TV Function Buttons

The TV buttons may not control all features of all models of GE, RCA, and ProScan TVs.

VCR BASICS

Numbers (0 through 9) Select a channel up to 99 by pressing two numbers. Select a cable channel over 99 by pressing and holding 1 until 1 -- appears on the screen. Then press the other two numbers.

POWER Turns the TV on and off.

SLOW + and - Used with some TV menus to select and adjust features.

VOL Up and Down Raises and lowers sound of TV.

Playing a Tape

1. Tune the TV to your VCR viewing channel (3, 4, or TV's video input).
2. Insert a tape in the VCR.

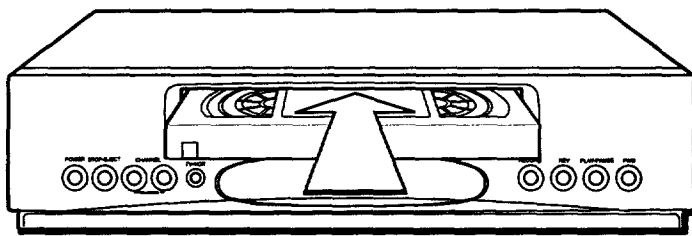

If the Auto Play feature is set to ON, the tape automatically begins playback (if the safety tab on the cassette is removed).

- Press FWD or REV to position the tape.
- Press PLAY (if necessary) to begin tape play.
- Press PAUSE for stop action.
- Press TRACKING up or down to remove any streaks from the picture, if necessary.
- Press STOP to stop playback.

Pause

If you pause, the VCR automatically switches from pause to stop after a few minutes to reduce tape wear.

Automatic Tracking

The VCR has automatic tracking which adjusts the picture when playing back a tape recorded on another VCR. Automatic tracking is turned on whenever a tape is inserted or the VCR's power is turned on.

Automatic Rewind

The VCR automatically rewinds the tape if it reaches the end of the tape during playback. While rewinding, you can press **POWER** and the VCR will turn off after rewinding.

Tape Eject

Press **EJECT** on the VCR when it is stopped to eject the tape.

Recording

If you want to record something that you're watching, you can use basic recording.

1. Press the **SPEED** button on the remote if you want to override the preferred **Tape Speed** setting.
2. Press the **RECORD** button to begin recording.
3. Press **STOP** to stop recording.

If you just want to pause the recording for a short time (like during a commercial), press **PAUSE** instead of **STOP**.

Check the Safety Tab

No matter which recording option you use, you need to make sure there is a tape in the VCR, and that the tape's safety tab is in place. You cannot record on a tape with the safety tab removed.

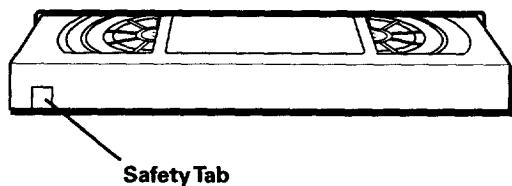

If the safety tab is removed and you want to record over it, simply cover the hole with vinyl tape.

RECORDING

Several Recording Options

Now that you've gone through the necessary steps to operate your VCR, I'll explain the different recording features that are available to suit your needs.

Recording features:

- Recording (explained in *VCR Basics* section)
- Express Recording
- Timer Recording
- Copying and Editing Tapes

1 FIRST THINGS FIRST



2 SETTING UP THE VCR



3 VCR BASICS



4 RECORDING



5 PROGRAMMING THE REMOTE



6 OTHER FEATURES



7 CONNECTIONS

RECORDING

Recording Features

There are three methods for recording programs:

- **Recording** lets you press one button to start recording a program. (See *VCR Basics* section.)
- **Express Recording** lets you start recording a program you are watching, and then set the VCR to automatically stop recording after a designated period of time.
- **Timer Recording** lets you program the VCR to automatically start and stop recording at a predetermined time.

Express Recording

Use express recording when you want to quickly record the remaining portion of the program you are watching.

1. Press the SPEED button on the remote if you want to override the preferred Tape Speed setting.
2. Press the RECORD button to begin recording.
3. Repeatedly press the RECORD button to set up the recording duration.

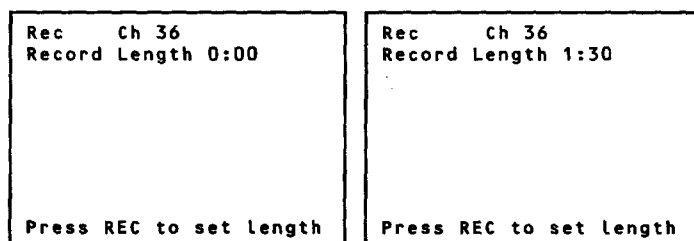

Each press of the RECORD button increases the recording time (up to 4 hours).

The VCR continues to record for the amount of time you indicate, and then automatically turns off.

To stop an express recording, press and hold the STOP button on the remote (STOP•EJECT button on the VCR) for a few seconds, or press STOP (STOP•EJECT) three times within 5 seconds.

Express Recording

Express recording is a great way to tape the last quarter of the game, or the last part of a movie when you have to leave.

RECORDING

Timer Recording

You can set up as many as eight timer recording programs.

1. Press MENU to display the VCR MAIN MENU.

```
VCR MAIN MENU
1 Timer Recordings
2 Time
3 Channels
4 Preferences
5 Language

0 Exit
```

2. Press 1 to display the TIMER RECORDINGS menu.

```
TIMER RECORDINGS

1 Create a New Program
2 Review Existing Progs.

0 Exit
```

3. Select 1 to CREATE A NEW PROGRAM.

```
How often should this
program record?

1 One time
2 Daily (every day)
3 Weekdays (M-F)
4 Weekly (once per week)

0 Cancel
```

4. Select how often you want the program to record.

```
Program 1 (One time)

Channel  --
Start Time --:--
End Time  -:--
Start Date --/--/--
Tape Speed SLP

Press MENU to cancel
```

5. Enter the data for the program with the number buttons.
The data includes the channel number (press INPUT to select the line input), start time including AM or PM, end time. The start date is automatically entered based on the VCR clock. Both the date and speed can be changed.

Timer Recording Information

Clock must be set correctly.

Insert a tape with the safety tab in place and enough tape to record the program.

PROGRAMS OVERLAP appears if you have entered two programs where the times overlap.

The output of your cable box appears in the "channel" item of the timer recording if you're set up for a cable box.

For cable box, turn on the cable box and tune it to the channel you want to record before the recording is to begin.

Tape Speed

The speed of your timer recording cannot be changed once the timer recording is saved. You must clear the timer and reprogram it.

Changing your preferred tape speed does not affect those timer recordings already programmed.

The factory setting for the VCR speed is SLP.

VCR playback is not affected by the preferred tape speed.

RECORDING

6. Review the information to make sure it is correct, and then press MENU to save.

```
Program 1 (One time)
Channel    03 Cable
Start Time 08:00 PM
End Time   09:30 PM
Start Date 10/24/97 Fri
Tape Speed SLP
           1=SP 2=SLP
Press CLEAR to correct
Press MENU to save
```

```
Program 1 has been saved
Remember to insert a
recordable tape and
turn the VCR off before
the program start time.
Press MENU to continue
```

Stopping a Timer Recording

To stop or cancel a timer recording in progress (even an express recording):

- Press and hold the STOP button on the remote (STOP•EJECT button on the VCR) for a few seconds, or press STOP (STOP•EJECT) three times within 5 seconds.

Review and Clearing Programs

To review programs that you have already set up:

1. Press MENU to display the VCR MAIN MENU.
2. Press 1 to display the TIMER RECORDINGS menu.

```
TIMER RECORDINGS
1 Create a New Program
2 Review Existing Progs.
0 Exit
```

3. Press 2 to display the REVIEW PROGRAMS screen.

```
Program 1 (One time)
Channel    104 Cable
Start Time 12:00 AM
End Time   01:30 AM
Start Date 10/24/97 Fri
Tape Speed SLP
Press CLEAR to erase
Press MENU for next prog.
```

4. Press CLEAR to erase or MENU to see the next program.

RECORDING

Using Two VCRs for Copying and Editing Tapes

Use one VCR as the *playback VCR* and the other as the *recording VCR*.

1. Turn on the TV and VCRs.
2. Tune the TV to the VCR viewing channel (either 3, 4, or TV's video input).
3. If you connected your VCR using the ANTENNA jacks, tune *recording VCR* to channel 3 or 4—the one selected on the back of the *playback VCR*.

If you connected your VCR using the audio/video jacks, press INPUT on the *recording VCR*'s remote to select the line input.

4. Insert the tape you want to copy into the *playback VCR*. Insert a blank tape with safety tab in place into the *recording VCR*.
5. When you reach the point on the tape or program where you want to begin copying, press PLAY•PAUSE and then PLAY•PAUSE again on the *playback VCR*. You may need to adjust the tracking.
6. Press the RECORD button, then press PLAY•PAUSE, on the *recording VCR*.
7. Press the PLAY•PAUSE buttons on *both VCRs* at the same time to begin copying the tape.
8. To edit segments that you do not want to copy:
 - Press PLAY•PAUSE on *recording VCR* to stop copying.
 - Locate the next segment you want to copy on *playback VCR* by using FWD, REV, and PLAY•PAUSE, and then press PLAY•PAUSE.
 - Press PLAY•PAUSE on *both VCRs* at the same time to resume copying.
9. Press STOP•EJECT on *both VCRs* when you are finished.

Caution:

The unauthorized recording of television programs or other materials may infringe on the rights of others.

Two VCR Connection

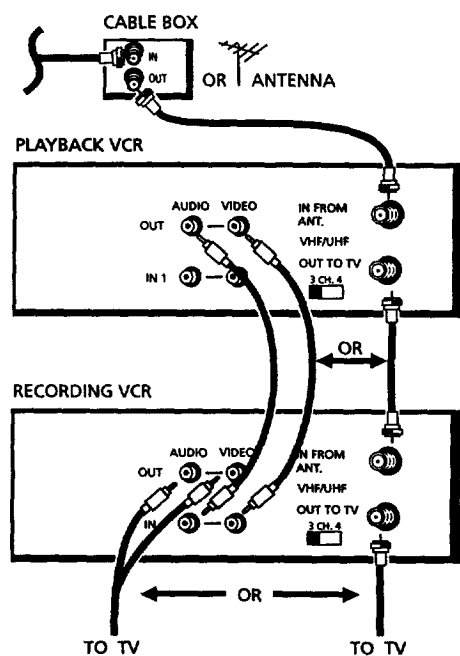

PROGRAMMING THE REMOTE

Control Your Other Components...

The remote can be programmed to control a television and satellite receiver or cable box.

It is initially programmed to control a GE, RCA, or ProScan TV and satellite receiver. Other manufacturers' brands need to be programmed.

1 FIRST THINGS FIRST



2 SETTING UP THE VCR



3 VCR BASICS



4 RECORDING



5 PROGRAMMING THE REMOTE



6 OTHER FEATURES



7 CONNECTIONS

PROGRAMMING THE REMOTE

About Programming the Remote

The remote can be programmed to control other brands or remote controllable TVs, digital satellite receivers, and cable boxes. It is already programmed to operate most GE, RCA, and ProScan televisions and digital satellite receivers.

Programming the Remote to Control a TV

If the TV does not turn on when you press the TV button, the remote needs to be programmed.

Follow these steps to program the remote to control your particular TV:

1. Turn on the TV.
2. Find your TV brand and code number(s) on the code list on the next page.
3. Press and hold the TV button on the remote.
4. Enter the three-digit code from the code list.
5. Release TV, and then press CHAN up or down. If the TV responds to the remote commands, the remote is programmed.
6. If the TV does not respond, repeat these steps using the next code listed for your TV's brand

Operate the TV

After you set up the remote, see which buttons operate your TV.

1. Point the remote at the TV, and press the TV button.
If the TV does not turn on, press the TV button and then press the PWR button.
2. You may want to experiment to see which buttons operate your TV. Try pressing buttons, such as VOL and MUTE. See "TV Function Buttons" in the *VCR Basics* Section for details.

This remote may not operate all models of the brands that are shown.

Note the difference between the TV and VCR on-screen displays to see which one the remote is operating.

PROGRAMMING THE REMOTE

TV Codes

Akai	03	NAD	07
AOC	06,12	NEC	06
Candle	06	Panasonic	04,08,11
Citizen	06	Philco	04,06,12
Colortyme	06	Philips	03,04,06,12
Concerto	06	Pioneer	06
Curtis Mathes	01,06	Portland.....	06,12
Daewoo	06,12	ProScan	01
Daytron	06	Proton.....	06
Electrohome	06,12	Quasar	11
Emerson.....	06	Radio Shack	01,05,13
Envision	05,06	RCA	01,06,12
Fisher	05,08	Realistic	05
GE	00,01,06,11	Sampo.....	06
Goldstar	06,12	Samsung	06,09,12
Hallmark	06	Sanyo	05,08
Hitachi	06,14	Sears	01,05,06,07, 08,10,12
Infinity	04	Sharp	06,13
J C Penney	00,01,06,09,12	Sony	03
JBL.....	04	Soundesign.....	06
Jensen	06	Sylvania	04,06,12
JVC	10,11	Technics	11
Kawasho	03,06	Techwood	06
Kenwood	06,12	Teknika	06
Loewe	04	TMK	06
Luxman	06	Toshiba	05,07,08,09
LXI	04,05,07	Universal	00
Magnavox	04,06,12	Victor	10
Marantz	04,06	Wards	00,01,04,06,12,13
MGA	06,12	Yamaha	12
Mitsubishi	06,12	Zenith	02
MTC	06		

PROGRAMMING THE REMOTE

Programming the Remote to Control a Digital Satellite Receiver or Cable Box

The remote is programmed to control an GE, RCA, or ProScan digital satellite receiver.

If you have another brand of cable box or digital satellite receiver with its own remote, you may be able to use the VCR's remote to operate it.

1. Turn on the cable box or digital satellite receiver.
2. Look up your brand and its code number(s) in the code list on the right.
3. Press and hold the SAT•CABLE button on the remote.
4. Enter the three-digit code from the code list.
5. Release the SAT•CABLE button and press POWER or CHAN up or down to see if the cable box or receiver responds to the remote commands.
6. Repeat these steps using the next code listed for your brand until the cable box responds to the remote commands.

Operate the Cable Box or Digital Satellite Receiver

After you have set up your remote, see which buttons will operate your cable box or digital satellite receiver.

1. Point the remote at the box or receiver, and press SAT•CABLE. If it does not turn on, press SAT•CABLE and then POWER.
2. You may want to experiment to see which buttons will operate your cable box or digital satellite receiver. Try pressing buttons, such as CHAN up or down.

Cable Box Codes

ABC.....	22,46,53,54
Anvision	07,08
Cablestar	07,08
Diamond	56
Eagle	07,08
Eastern International	02
General Instrument	04,05, 15,23,24,25,30,36,46
Hamlin.....	12,13,34,48
Hitachi.....	37,43,46
Jerrold	04,05,15,23, 24,25,30,36,45,46,47
Macom	37,43
Magnavox	07,08,19,21, 26,28,29,32,33,40,41
NSC	09
Oak	01,16,38
Oak Sigma.....	16
Panasonic	03,27,39
Philips	07,08,19,21,26,28, 29,32,33,40,41
Pioneer	18,20,44
Randtek.....	07,08
RCA.....	00,27,60
Regal	12,13
Regency.....	02,33
Samsung.....	44
Scientific Atlanta	03,22,35
Signature	46
Sprucer	27
Starcom	46
Stargate 2000	58
Sylvania	11,59
Teknika.....	06
Texscan	10,11,59
Tocom	17,21,49,50,55
Unika	31,32,41
Viewstar	07,08,19,21,26, 28,29,32,33,40,41
Warner Amex	44
Zenith	14,42,57

Satellite Receiver Codes

GE	00
Panasonic	97
ProScan	00
RCA.....	00
Toshiba	96
Sony.....	95

This remote may not operate all models of the brands that are shown.

OTHER FEATURES

Features to Enhance VCR Operation

- Picture Search Options
- Pro-Tect Plus™ Locking Feature
- Time Counter
- On-Screen Displays
- Tracking

1 FIRST THINGS FIRST



2 SETTING UP THE VCR



3 VCR BASICS



4 RECORDING



5 PROGRAMMING THE REMOTE



6 OTHER FEATURES



7 CONNECTIONS

OTHER FEATURES

Picture Search Options

The most basic way to search during playback is using the forward and reverse functions. This section contains several other options available for searching a tape.

Search features work well for tapes recorded at the SLP speed.

Forward and Reverse Search

You can view a tape during play or play-pause. Sound is turned off during picture search.

1. Press FWD to search forward or REV to search in reverse.
2. Press FWD or REV again or press PLAY on the remote (PLAY•PAUSE on the VCR) to return to normal playback.

Slow Motion

You can view a tape during play or play-pause using slow motion. Slow motion works best for tapes recorded at the SLP speed.

1. Press SLOW+ or SLOW- on the remote to begin slow motion playback.
2. Use TRACK up or down to remove any streaks from the picture.
3. Use SLOW+ or SLOW- on the remote, or FWD and REV on the VCR to speed up or slow down slow motion playback.
4. Press PLAY on the remote (PLAY•PAUSE on the VCR) to return to normal playback.

The VCR switches automatically from slow-motion playback to stop after a few minutes.

Commercial Scan (Search Button)

This is useful for skipping commercials or short program segments.

- Press SEARCH once during playback to advance the tape approximately 30 seconds of recorded material.
- Each press of the SEARCH button adds an additional 30 seconds up to 5 minutes.

Insert Tape

Remember to insert a recorded tape when using the search features.

OTHER FEATURES

Frame Advance

Frame advance lets you view one-stop action frame after another.

1. Press PAUSE or F.ADV on the remote (PLAY•PAUSE on the VCR) to freeze the action.
2. Press F.ADV each time you want to view the next frame of the scene.
3. Press PAUSE or PLAY on the remote (PLAY•PAUSE on the VCR) to return to normal playback.

Index Search

The VCR has a "VHS Index Search System" that automatically records an index mark on the tape every time you start recording. During playback you can locate the program you want to play by the number of index marks or by scanning. The VCR will search forward or reverse from the location you are on the tape.

To Search:

1. Stop the tape and press SEARCH on the remote to display the INDEX SEARCH menu on the TV screen.
2. If you want to search through a certain number of index marks, press two number buttons to enter the number of marks you want to search. Press CLEAR on the remote to correct an entry.
3. Press FWD to search forward or REV to search in reverse. The VCR will locate your index mark and begin playback. If you did not enter a specific index number, the VCR will locate the next index mark and begin playback.
4. Press STOP to stop index searching.

Some index marks may be missed by the VCR:

- A mark too close to your location on the tape.
- The mark at the beginning of a recorded segment of five minutes or less.
- The first index mark on the tape when you start at the beginning of the tape.

```
INDEX SEARCH
Press REV or FWD
to begin scanning
or
enter a specific
index number
--
Press SEARCH to exit
```

```
INDEX SEARCH
Press REV or FWD
to begin search
Index number
  12
Press SEARCH to exit
```

```
INDEX SEARCH
Searching for
index number 12...
Press STOP to cancel
```

OTHER FEATURES

Zero Search

The zero search feature enables the VCR to quickly return to a counter reading of 0:00:00 anywhere on the tape. This is especially convenient when you want to repeat a segment of the tape several times.

1. Go to the beginning of the program you wish to return to.
2. Press INFO **twice** to display the timer counter on the TV screen
3. Press CLEAR to reset the counter to 0:00:00.
4. Continue playing the tape.
5. Press STOP.
6. Press SEARCH on the remote **twice** to display the ZERO SEARCH menu.
7. Press REV to return to 0:00:00 on the tape.

```
ZERO SEARCH
Current tape counter is
2:17:25
Press REV to go to
0:00:00
Press SEARCH to exit
```

```
ZERO SEARCH
Searching for
0:00:00
Press STOP to cancel
```

Pro-Tect Plus™ Locking Feature

To disable the usage of the VCR, or to protect your timer recordings, you can lock the VCR so that the buttons on the VCR or remote won't work.

- To lock: Press and hold either the remote's POWER or OFF button. The front panel POWER indicator flashes when the feature is activated. POWER will also flash if you attempt to turn on the VCR while the feature is on.
- To unlock the feature and turn on the VCR: Press and hold either the remote's POWER or VCR button.

OTHER FEATURES

Time Counter

The time counter shows the actual time it takes to record a program or play back a segment of a recorded tape. It helps locate the beginning or end of programs you taped. The time counter resets to 0:00:00 whenever the tape is ejected from the VCR.

For example, if you record a 30-minute program at the beginning of the tape and you want to go to the end of that program to begin another recording, you would:

1. Press INFO **twice** to display the time counter.
2. Press CLEAR to reset the time counter to 0:00:00.
3. Press FWD to forward the tape until the time counter reads 0:30:00.
4. Press STOP. This is the approximate end of the program. (You may want to press PLAY to verify.) Now, you can begin recording at this spot.
5. Press INFO to remove the time counter from the screen and return to the normal display mode.

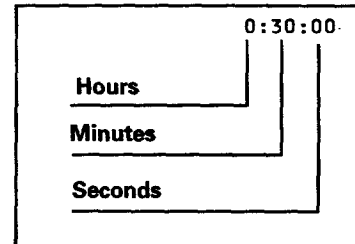

On-Screen Displays

The INFO button shows the status of the VCR (STOP, PLAY, RECORD, etc.), channel number, time counter, date, time, and tape speed on the TV screen. The date and time must be set before they can be displayed.

1. Press INFO to see the on-screen displays.
2. Press INFO again to have only the time counter remain on the screen.
3. Press INFO again to return to the normal display. No displays appear on the screen.

Turning off the VCR also resets the displays.

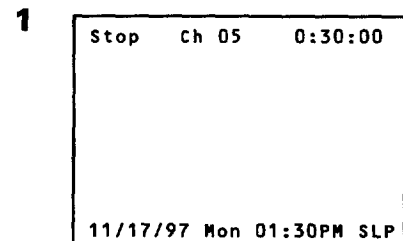

On-screen display (times out)

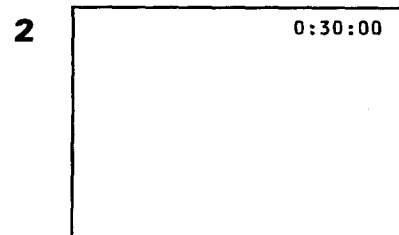

*Timer counter only
(does not time out)*

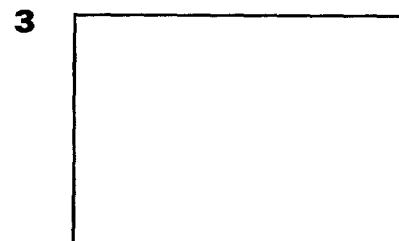

Normal display

OTHER FEATURES

Tracking

Your VCR has automatic tracking which removes the streaks or snow from the picture. Automatic tracking is activated when you insert a tape or turn on the VCR. Occasionally you may need to manually adjust tracking, especially if the tape was recorded on a different VCR. Just use the TRACKING buttons to remove the streaks or snow. You can also use tracking when you PAUSE a tape to reduce jittering of the picture.

When you manually adjust the picture, automatic tracking is turned off. To turn automatic tracking back on, press both TRACKING buttons on the front of the VCR at the same time, or eject the tape and re-insert it.

Tracking has no effect during recording—only playback.

CONNECTIONS

Things to Know Before Connecting Components

Protect Your Components from Power Surges

- Connect all components before plugging any power cords into the wall outlet.
- Always turn off the TV and other components before you connect or disconnect any cables.

Position Cables Correctly to Avoid Audio Hum or Interference

- Insert all cable plugs firmly into their jacks.
- Place the audio/video cables to the sides of the TV's back panel instead of straight down the middle after you connect your components.
- Try not to coil any twin-lead cables and keep them away from the audio/video cables as much as possible.
- Make sure all antennas and cables are properly grounded. Refer to the Safety Tips sheet packed with your unit.

Protect Your Components from Overheating

- Do not block ventilation holes in any of the components. Arrange the components so that air can circulate freely.
- Do not stack components.
- Allow adequate ventilation when placing your components in a stand.
- Place an amplifier or satellite receiver on the top shelf of the stand so heated air rising from it will not flow around other components.

1 FIRST THINGS FIRST



2 SETTING UP THE VCR



3 VCR BASICS



4 RECORDING



5 PROGRAMMING THE REMOTE



6 OTHER FEATURES



7 CONNECTIONS

CONNECTIONS

Connecting Your VCR

Refer to these pages to help you connect your VCR.

Jacks and Cables

RF Jacks and Antenna Cables (F-type)

The RF jacks provide good picture and mono sound, and must be used if audio/video connections are not available for your TV.

These jacks are required for antenna or cable-TV connections. The RF jacks on the VCR are labeled IN FROM ANT. and OUT TO TV. The antenna cable supplied with your VCR is used to connect the VCR's OUT TO TV jack and your TV's antenna input.



RF Jack

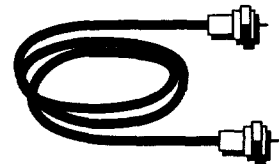

Audio/Video Jacks and Cables (RCA-type)

The audio/video jacks provide very good picture and sound and can be used if your TV has audio/video input jacks.

These jacks are used for most audio/video connections. The VCR audio/video jacks are color coded (yellow for video and white for left audio). If your TV has two inputs for audio (stereo), connect the one labeled mono. If one is not labeled mono, you may need a Y-adapter.



Audio/Video Jack

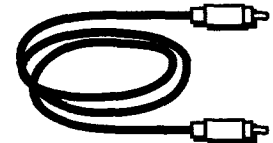

CONNECTIONS

Choosing a VCR Connection

There are several different ways to hook up your VCR, depending on whether or not you have cable, and if you have cable, whether you have a cable box, and if some of the channels are scrambled and...well, you get the picture.

Three connections are described in this section and one of them should provide you with a VCR hookup that works.

- TV with RF jack only
- TV with audio/video jacks
- TV with audio/video jacks and cable box to unscramble pay channels only

If you need to hook up additional components not shown in the diagrams here (and are unsure of how to connect them), refer to the instruction manual that came with that particular component.

Advantages of Audio/Video Cable Connections

Using a simple antenna cable connection gives you good picture quality. If your television has A/V jacks, I highly recommend using them to get even better picture and sound when recording and playing back videotapes. These connections give you more convenient operation by not sharing the signal from the RF cable.

Don't Forget About the Auto TV/VCR Feature

The TV/VCR switch controls whether the picture signal is coming from the VCR or the TV. The TV/VCR feature automatically switches the VCR to the VCR model when the VCR is turned on or you press the PLAY button. You can change the setting manually by using the TV•VCR button on the remote.

CONNECTIONS

TV With RF Jack Only

This connection assumes:

- You are connecting antenna, cable, or cable box system.
- Your television has only an RF input jack.

This connection provides:

- Mono sound playback from VCR.
- Record one channel while watching another (except when using a cable box for all channels).

To use this connection, you must have:

- (1) antenna cable for cable or antenna connection; (2) for cable box

To connect:

1. Connect cables as shown.
2. Return to *First Things First*, then follow the steps.

Using This Connection

Tune your TV to channel 3 or 4 whichever one you selected with the switch on the back of the VCR. Use the TV•VCR button to watch the VCR.

To play a tape:

1. Insert a tape.
2. If necessary, press PLAY.

To record one program and watch another:

1. Begin recording a program using one of the recording options.
2. Press the TV•VCR button and select a different channel on the TV.

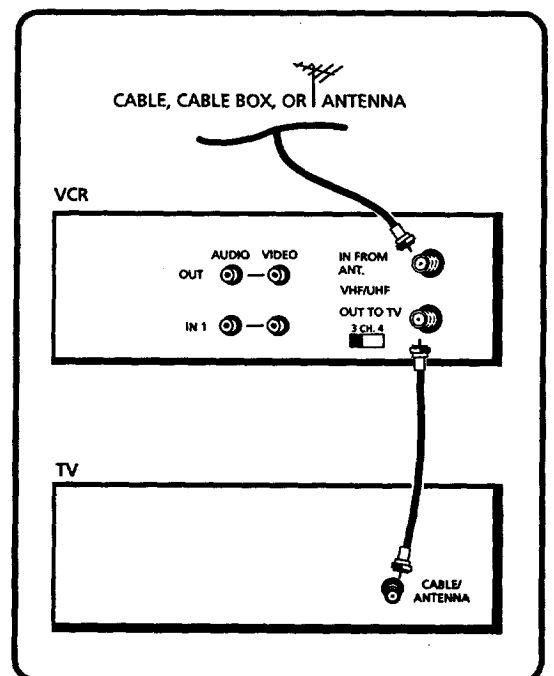

CONNECTIONS

TV With Audio/Video Jacks

This connection assumes:

- You are connecting an antenna, cable, or cable box system.
- Your television has audio/video jacks.

This connection provides:

- Mono sound playback from VCR.
- Record one channel while watching another (except when using a cable box for all channels).

To use this connection, you must have:

- (1) antenna cable for cable/antenna connection; (2) for cable box
- (2) audio/video cables

To connect:

1. Connect cables as shown.
2. Return to *First Things First*, then follow the steps.

Using This Connection

Tune your TV to its video input channel.

To play a tape:

1. Insert a tape
2. If necessary, press PLAY.

To record one program and watch another:

1. Begin recording a program using one of the recording options.
2. Select a different channel on the TV.

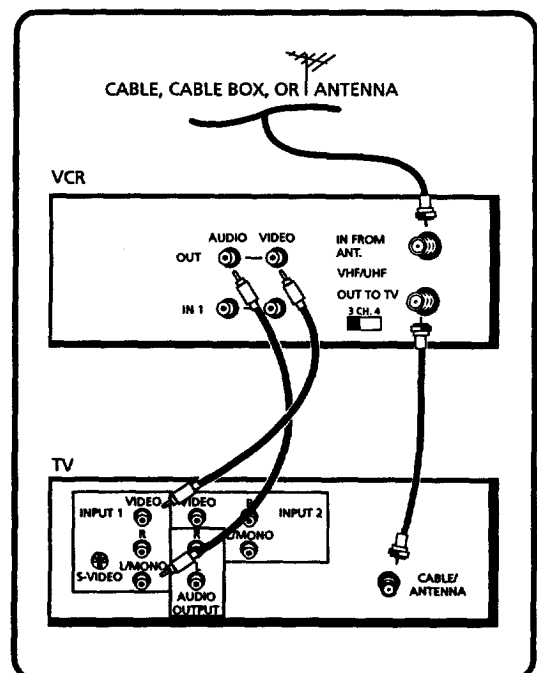

CONNECTIONS

TV With Audio/Video Jacks and Cable Box to Unscramble Pay Channels Only

This connection assumes:

- You are using a cable box only to unscramble premium channels.
- Your TV has audio/video input jacks.

This connection provides:

- Mono sound playback from VCR.
- Recording a scrambled or unscrambled channel through the cable box while watching an unscrambled channel.

To use this connection, you must have:

- (3) antenna cables
- (2) audio/video cables
- (1) splitter

To connect:

1. Connect cables as shown.
2. Return to *First Things First*, then follow the steps.

Using This Connection

Tune your TV to its video input channel.

To play a tape:

1. Insert a tape
2. If necessary, press PLAY.

To record a scrambled or unscrambled program and watch another unscrambled:

1. Begin recording a scrambled program through the cable box using one of the recording options.
2. Select an unscrambled channel on the TV.

All scrambled channels must be viewed through the VCR.

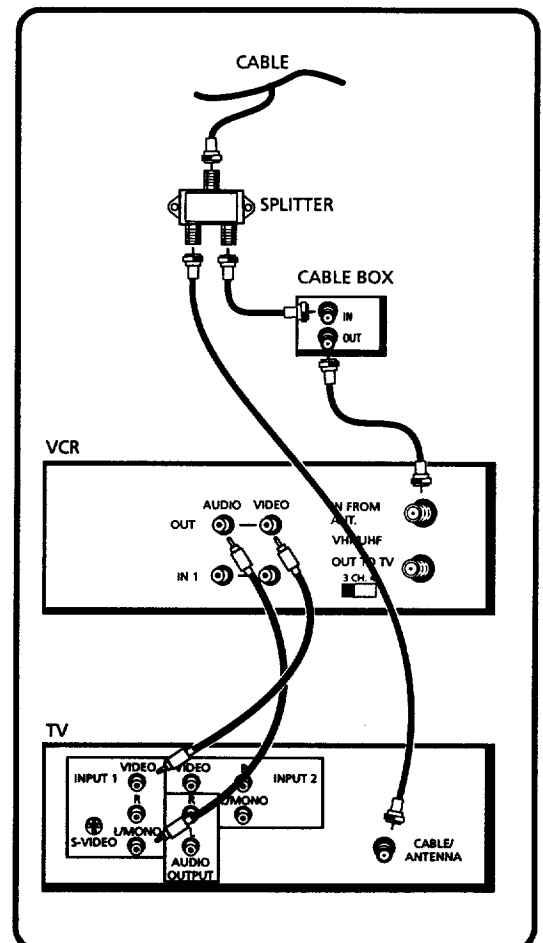

APPENDIX A: REFERENCE

This section gives you some additional information about the VCR, including a description of the unit's controls and display.

You also will find a Troubleshooting Tips section in this Appendix, which might help to resolve some of those simple problems.

Finally, this section contains your warranty information.

APPENDIX A: REFERENCE

Front Panel

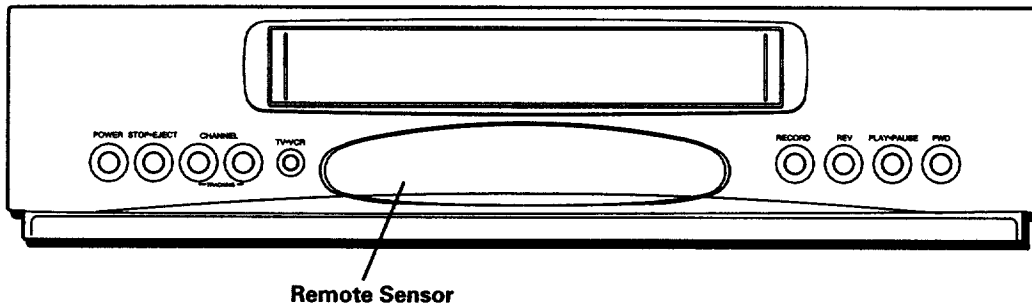

CHANNEL•TRACKING Up or Down Selects next higher or lower channel in the VCR's channel memory. Adjusts tracking when a tape is playing.

FWD Forwards the tape when the VCR is stopped. Searches the picture forward during playback.

PLAY•PAUSE Plays a tape. Pauses action for viewing during playback. Pauses recording to prevent recording of unwanted scenes.

POWER Turns the VCR on or off.

RECORD Starts VCR recording. Used for express recording.

Remote Sensor Receives signals from the remote control. Aim the remote at this sensor.

REV Rewinds the tape when the VCR is stopped. Searches the picture in reverse during playback.

STOP•EJECT Stops the normal functions such as record, playback, rewind, fast-forward, or pause. Ejects the tape when the VCR is stopped.

TV•VCR Switches the picture signal so that it either comes from the VCR or the TV.

APPENDIX A: REFERENCE

Back Panel

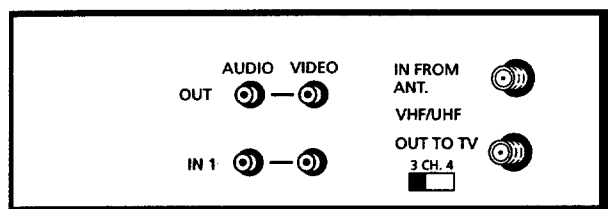

3 CH. 4 Switch Selects the channel to which you will tune the TV to see the VCR picture if you connect the VCR using the ANT.IN and RF OUT jacks.

AUDIO and VIDEO IN Jacks Receives signals from another component, like a VCR or camcorder, when it is connected to these jacks. Use INPUT on the remote to select.

AUDIO and VIDEO OUT Jacks Sends signals from VCR to another component, like a TV or VCR, when it is connected to these jacks.

IN FROM ANT. Jack Receives a signal from an antenna or cable system when attached.

OUT TO TV Jack Passes signal to TV using the cable supplied.

Indicator Panel

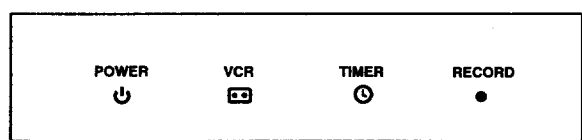

POWER Indicator Lights when the VCR is turned on.

RECORD Indicator Lights when the VCR is recording.

TIMER Indicator Lights during an express or timer recording, or when the VCR is set for a timer recording and the VCR is turned off. Flashes when a timer recording is set, and there is no cassette in the VCR, and when the clock is not set.

VCR Indicator (Applies Only if the VCR Viewing Channel is 3 or 4). Press the TV•VCR button to turn on or off.

- VCR indicator on: Picture from VCR.
- VCR indicator off: Picture from TV channel.

APPENDIX A: REFERENCE

Troubleshooting Tips

No power

- Check to make sure it is plugged into an operating outlet.
- Check to make sure your connections are correct.

VCR does not respond to remote

- Check to make sure there are no objects between the VCR and remote.
- The batteries may need changing.
- Make sure the Remote VCR1/VCR2 setting is set to VCR1 so the remote that came packed with your VCR can operate it.
- Remove batteries and hold number button 1 for at least 60 seconds to drain the microprocessor inside the remote. Release number 1 and replace the batteries.

Poor or no picture for normal TV viewing

- Check to make sure the VCR indicator is off.
- Check to make sure the TV is switched to an active channel.
- Check to make sure the antenna connections are secure and correct.

Snowy or no picture during playback

- Press TV•VCR to turn VCR indicator on.
- Check TV channel selected (3 or 4) to make sure it matches the channel selected with 3 CH. 4 switch on back of VCR.
- Check to make sure the TV's fine tuning is correct for the channel you have selected.
- Check video cable connections between VCR and TV monitor.
- Check to make sure the TV monitor is set to video input channel.
- Try another tape.
- Some snow/streaks are normal during search, stop action, frame advance, and slow-motion playback.

Streaks in picture during normal playback

- Press one of the TRACKING buttons to move streaks up or down for the best picture.
- Check to make sure the tape is of good quality and not worn out.

Time counter not working or time counter not working in search modes

- The time counter does not advance during unrecorded portions of tape. When an unrecorded segment of tape is encountered, the time counter will hold its count until recorded material is detected again.
- A minus (-) will appear in front of the time if you rewind the tape farther back than a counter reading of 0:00:00.
- The time counter disappears during search; this is normal.

APPENDIX A: REFERENCE

Will not record or play

- Check to make sure there is a tape in the VCR.
- Try ejecting and reinserting the cassette.
- Check to make sure the tape is not broken.
- Check to make sure the VCR is not in pause mode. Press PAUSE or PLAY on the remote (PLAY•PAUSE on the VCR) to return to normal playback.

Will not record

- Check to make sure the safety tab is intact.
- Check to make sure the VCR is not in the line mode. Press INPUT on the remote.

Rewind does not operate

- Check to make sure the tape is not already rewound.

Timer recording not made or wrong program recorded

- Check to make sure the cable box was turned on when recording was to begin.
- Check to make sure the program was entered correctly (wrong channel or times).
- Power interruption. Reset the clock.
- Check to see if time and date are correct—including AM/PM.
- Check to make sure the program did not exceed the tape's length or the tape was not rewound beforehand.
- Check to make sure the VCR was turned off at the time recording was to start.
- Check to make sure there was a tape in the VCR and the cassette's safety tab was intact.
- VCR ejects cassette when the end of the tape is reached during a timer recording.

Internal clock shows incorrect time or date

- Power interruption.
- Check to make sure the clock is set accurately (check AM/PM and date).
- Check Auto DST setting. The clock may have adjusted for daylight-saving time.

Time did not adjust for daylight-saving time

- Check to make sure Auto DST feature is turned on.

VCR makes noise when stopped

- VCR is removing tape from heads. This is normal. The head cylinder inside the VCR will continue to rotate for a few minutes after you put the VCR in the stop mode.

APPENDIX A: REFERENCE

Will not Auto Channel Search active channels correctly

- Check to make sure the antenna connections are secure and correct.
- Check to make sure the SignalType: CABLE/ANTENNA feature is set correctly.
- If Detect Automatically was selected for the SignalType in the Auto Channel Search menu, try using either CABLETV or ANTENNA instead.
- May not need to auto channel search if using a cable box. Refer to the VCR Channel List or contact your cable company for more information.

Cannot add or remove channels

- Channels must be placed in memory using the AUTO CHANNEL SEARCH feature before channels can be added or removed from channel memory.

Tape plays back in slow motion

- Press PLAY to return to normal playback.

Cannot select channels over 69

- Cable channels over 69 can only be selected if SignalType: CABLE/ANTENNA feature is set to CABLE.

Cassette with safety tab removed does not start to play automatically

- Check to make sure the Auto Play ON/OFF feature is set to ON.

TIMER indicator flashes

- Check to make sure there is a cassette in the VCR when a timer recording is set.

On-screen menus appear in an incorrect language.

- Use the Language feature to change the on-screen display language.

APPENDIX A: REFERENCE

Specifications

Format:	VHS
Record/Playback System:	Video: 2-Head Audio: Mono record/playback
Video Signal System:	EIA standard: NTSC color
Antenna:	75-ohm external VHF/UHF combined antenna terminal
Tuner:	USA: 181 channels capability* (125 cable channels) Canada: 178 channels capability* (122 cable channels)
Type:	AutoProgramming frequency synthesis
Power Requirement:	120V AC, 60 Hz
Power Consumption:	18 watts (standby < 4 watts)
Dimensions:	3.7 inches high (93 mm) 14.2 inches wide (360 mm) 12 inches deep (300 mm)
Weight:	7.5 pounds (3.4 kg)
Storage Temperature Range:	- 22°F to +149°F (-30°C to +65°C)
Operating Temperature Range:	+41°F to +104°F (+5°C to +40°C)

*Check your cable company's compatibility requirements.

Cleaning the VCR

Use a soft cloth or dusting attachment of your vacuum cleaner to dust your VCR. Remove dust from the ventilation holes on the top, back, sides, and bottom of the cabinet.

Plastic surfaces are easily scratched and can be marred by alcohol and various solvents. Avoid excessive use of oil-based furniture polishes since the materials used in the cabinet will accumulate more dust. We recommend using a nonabrasive, antistatic cleaner and polisher.

Specifications are subject to change.

APPENDIX A: REFERENCE

Limited Warranty

What your warranty covers:

- Any defect in materials or workmanship.

For how long after your purchase:

- 90 days for labor charges.
- One year for parts.

The warranty period for rental units begins with the first rental or 45 days from date of shipment to the rental firm, whichever comes first.

What we will do:

During the initial 90 days

- Pay any Authorized GE VCR Service Center the labor charges to repair your VCR.
- Pay any Authorized GE VCR Service Center for the new or, at our option, refurbished replacement parts required to repair your VCR.

How you get service:

- Take your VCR to any Authorized GE VCR Service Center. To identify your nearest Authorized GE VCR Service Center, ask your dealer, look in the Yellow Pages, or call 1-800-447-1700.
- Show the Authorized Service Center Representative your evidence of purchase date or first rental.
- Pick up your VCR when repairs are completed.

What your warranty does not cover:

- Customer instruction. (Your Owner's Manual clearly describes how to install, adjust, and operate your VCR. Any additional information should be obtained from your Dealer.)
- Installation and related adjustments.
- Signal reception problems not caused by your VCR.
- Damage from misuse or neglect.
- Cleaning of video/audio heads.
- Batteries.
- A VCR that has been modified or incorporated into other products or is used for institutional or other commercial purposes.
- A VCR purchased or serviced outside the USA.
- Acts of God, such as but not limited to lightning damage.

Product Registration:

- Please complete and mail the Product Registration Card packed with your VCR. It will make it easier to contact you should it ever be necessary. The return of the card is not required for warranty coverage.

How state law relates to this warranty:

- This warranty gives you specific legal rights, and you also may have other rights that vary from state to state.

If you purchased your VCR outside the United States:

- This warranty does not apply. Contact your dealer for warranty information.

INDEX

3 CH. 4 switch 47

A

Accessing menus 5
Audio/video jacks 18, 47
Auto play feature 20
Automatic rewind 21

C

Cable box codes 32
Cable box setup 8, 9
Cables 39, 40
Channel, viewing 5
CHANNELS menu 9
Cleaning the VCR 51
Clearing programs 26
Commercial scan feature 34
Component buttons 18
Connections 39–44

E

EnergySaver 15
Express recording 24

F

Front panel controls 46

I

Index search feature 35
Indicator panel 47
Interactive Setup 5

J

Jacks, types of 40

L

LP tape speed 16

M

Menus, accessing 5

N

Number button 20
Number buttons 19

O

On-screen displays 37
Overheating 39

P

Panel, indicator 47
Picture search options 34
Playing a Tape 20
Programming the remote 29–32
PROGRAMS OVERLAP message 25

R

Recording 21, 23–26
Remote sensor 46
Reviewing programs 26

S

Safety tab 21
Search 34–36
SLP tape speed 16
SP tape speed 16
Specifications 51
Stopping a timer recording 26

T

Tab, safety 21
Tape eject 21
Tape, playing a 20
Time counter 36
Timer recording 25
 stopping 26
Troubleshooting tips 48–50

W

Warranty, limited 52

Z

ZERO search feature 36

If your VCR needs service, please contact your dealer or the nearest Service Center from the yellow pages. Please do not send any products to the Indianapolis address listed in this manual or on the carton. This will only add delays in service for your product.

 **THOMSON CONSUMER ELECTRONICS**

10330 North Meridian Street
Indianapolis, IN 46290

©1998 Thomson Consumer Electronics, Inc.

Trademark(s)® Registered

Marca(s) Registrada(s)

Printed in Singapore

TOCOM 15313560

VQTS3466 (A)

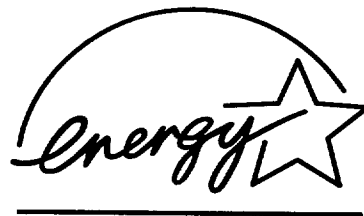

As an ENERGY STAR® Partner, Thomson Consumer Electronics has determined that this product or product model meets the ENERGY STAR® guidelines for energy efficiency.