

USER'S GUIDE



TV/VCR COMBINATION

TRENT

Important Information



CAUTION
RISK OF ELECTRIC SHOCK
DO NOT OPEN



TO REDUCE THE RISK OF ELECTRIC SHOCK, DO NOT REMOVE COVER (OR BACK). NO USER SERVICEABLE PARTS INSIDE. REFER SERVICING TO QUALIFIED SERVICE PERSONNEL.



This symbol indicates "dangerous voltage" inside the product that presents a risk of electric shock or personal injury.



This symbol indicates important instructions accompanying the product.

WARNING

To reduce the risk of fire or shock hazard, do not expose this product to rain or moisture.

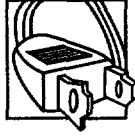

CAUTION: To prevent electric shock, match wide blade of plug to wide slot, fully insert.

ATTENTION: Pour éviter les chocs électriques, introduire la lame la plus large de la fiche dans la borne correspondante de la prise et pousser jusqu'au fond.

Cautions

FCC regulations state that unauthorized changes or modifications to this equipment may void the user's authority to operate it.

Note to Cable TV Installer

This reminder is provided to call your attention to Article 820-40 of the National Electrical Code (Section 54 of the Canadian Electrical Code, Part 1) which provides guidelines for proper grounding and, in particular, specifies that the cable ground shall be connected to the grounding system of the building as close to the point of cable entry as practical.

Product Registration

Please fill out the product registration card and return it immediately. Returning this card allows us to contact you if needed.

Keep your sales receipt to obtain warranty parts and service and for proof of purchase. Attach it here and record the serial and model numbers in case you need them. The numbers are located on the back of the TV/VCR combination.

Model No. _____

Serial No. _____

Purchase Date: _____

Dealer/Address/Phone: _____

Table of Contents

Important Information

Warning	i
Cautions	i
Note to Cable TV Installer	i
Product Registration	i

Setting Up the TV/VCR

Startup	
Check Accessories With TV/VCR	2
Insert Batteries in Remote	2
Optional: Attach Hook for Remote	3
Connect Antenna or Cable-TV System	3
Swivel the TV/VCR Into Position	3
Turn On the TV/VCR	3
Set the Clock and Auto Channel Search Automatically	4
Set the Clock Manually	4
Add or Remove Channels from TV/VCR's Memory	5
Select the Language. (Escoge una Lengua.)	5
Select a Channel and Adjust the Volume	5

Using the Remote Control

Buttons	6-7
---------	-----

Using the TV/VCR Features

On-Screen Displays	8
Adjust the Video	8
Closed Captions	9
Sleep Timer	10
Wake-Up Timer	10

Playing a Tape

Operating Instructions	11
Using the Playback Features	
Pause	12
Picture Search	12
Automatic Tracking	12
Manual Tracking	12
Time Counter	13
Auto Play Feature	14
Auto Repeat Feature	14

Recording a Program

Recording Features

Recording Speeds	15
Recording Pause	15
Types of Recordings	15
Basic Recording –	
Operating Instructions	15
Recording While You're Away	
Timer Recording	16
Checking or Clearing Timer Recordings	17
Stopping a Timer Recording	17
Express Recording	18
Copying and Editing Tapes	19

Location of Controls

Front Panel	20
Back Panel	21

Hooking Up the TV/VCR

Choosing a Hookup	21
Connect Supplied Antenna, Antenna, or Cable System Without Cable Box	22
Connect Cable System With Cable Box to Unscramble All Channels	23
Connect Cable System With Cable Box to Unscramble Only Premium Channels	23
Connect VCR or Camcorder for Copying Tapes	24

References

Cleaning the TV/VCR	25
Specifications	25
Trouble Checks	26-27
Limited Warranty	28
Index	29

Startup

1. Check accessories with TV/VCR combination.

Contact your dealer if any items are missing.

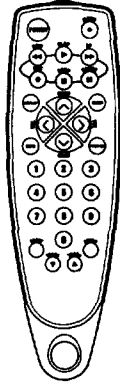

Remote
(Stock No. 221374)

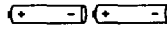

2 "AAA" Batteries

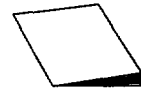

Videotape Catalog



Hook
(Stock No. 232921)

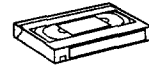

Cooking Tape



One (1) Screw



Antenna Adapter
(300-75 Ohm)
(Stock No. 232919)

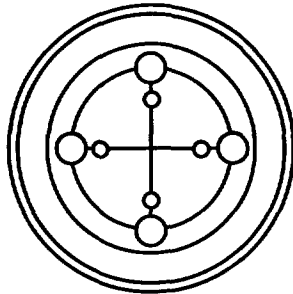

Swivel Base
(Stock No. 232777)

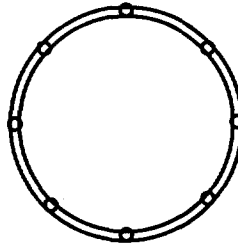

Swivel Bearing Guide
(Stock No. 232778)

Swivel Bearings
(Stock No. 232779)

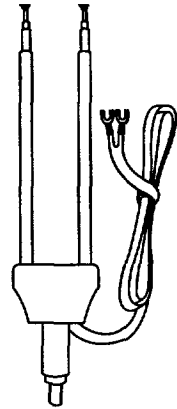

VHF/UHF Dipole Antenna
(Stock No. 232920)

2. Insert batteries in remote.

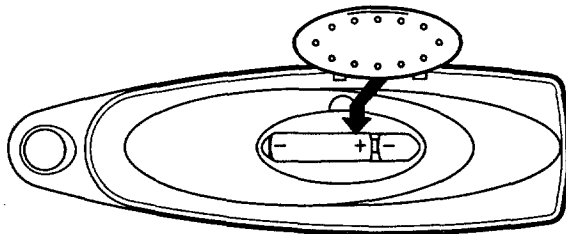

Startup

3. Optional: Attach hook for remote.

Attach the hook in a convenient location for storing your remote when it is not in use.

4. Connect antenna or cable-TV system.

Connect the supplied dipole antenna, a different home antenna, or a cable-TV system. *Details on pages 21-23.*

5. Connect the Swivel Base to the TV/VCR.

Position the swivel base with the center hole over the screw location in the center of the bottom of the TV/VCR. Make sure the side with the ball bearing ring is touching the bottom of the TV/VCR. Insert the provided screw. Position the TV/VCR bottom down.

Swivel the TV/VCR into the viewing position.

Moving the TV/VCR while it is operating may cause a rainbow effect from the Earth's magnetic field or nearby appliances.

6. Turn on the TV/VCR.

Press POWER on the TV/VCR or remote. The indicator in the POWER button on the front of the TV/VCR will light.

7. Put Channels into Memory (Auto Channel Search)

- A. Press MENU on the remote to display the TV/VCR MAIN MENU.
- B. Press 5 to display the SETUP menu.
- C. Press 1 to display the AUTO CHANNEL SEARCH menu.
- D. Allow the TV/VCR to search for all channels. Pressing any buttons during the Auto Channel Search will stop the search and only some channels will be in the TV/VCR's memory. When the search is finished the TV/VCR will automatically tune to the first channel in its list.

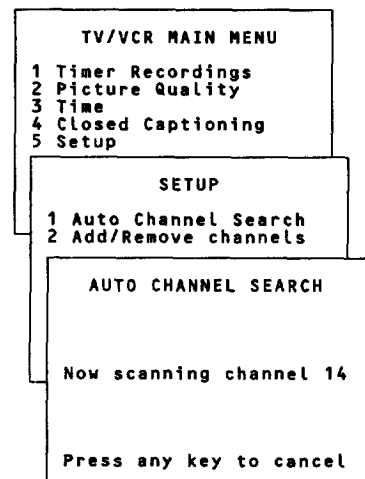

8. Set the Signal Type (optional).

The TV/VCR automatically selects the signal type (cable or antenna) when you auto channel search in step 6. If you want to change the signal type, follow the directions below.

- A. Press MENU on the remote to display the TV/VCR MAIN MENU.
- B. Press 5 to display the SETUP menu.
- C. Press 5 to change the Signal Type.

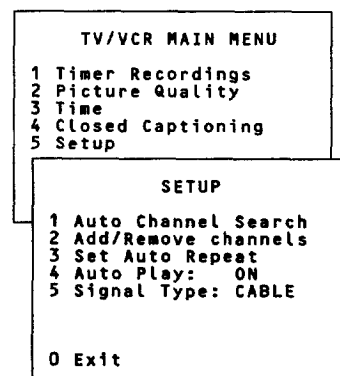

Startup

9. Set the clock manually.

- If you want to manually set the clock:
- A. Press MENU on the remote to display the TV/VCR MAIN MENU.
 - B. Press 1 to display the TIME menu.
 - C. Press 1 to display the SET TIME AND DATE screen.
 - D. Use the number buttons on the remote to enter the time including AM or PM, month, day, and year. The day of the week will automatically appear after you enter the year.
 - Press 0 before single-digit numbers. Press 1 for AM or 2 for PM. Example: press 0, then 5, then 0, then 7, then 2 for a time of 5:07PM.
 - Press CLEAR on the remote at any time to change incorrect entries.
 - E. Press MENU on the remote to start the clock.
- To display the time and date, press DISPLAY on the remote.

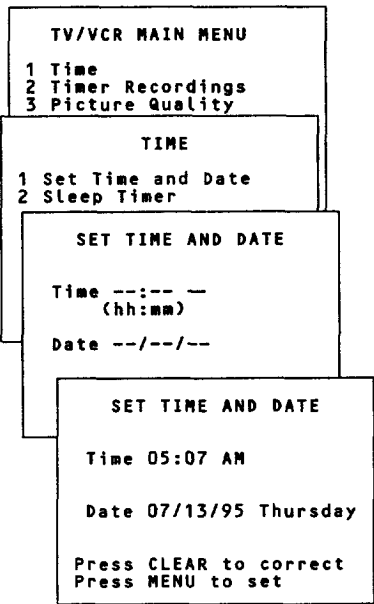

10. Add or remove channels from the TV/VCR's memory.

- You may want to add or remove channels if some of them are not active, have weak signals, or you do not want them in your channel memory. A channel that has been removed can still be selected by pressing number buttons.
- A. Press MENU on the remote to display the TV/VCR MAIN MENU.
 - B. Press 5 to display the SETUP menu.
 - C. Press 2 to display the ADD/REMOVE CHANNELS screen.
 - D. Follow the directions on the screen to add or remove a channel.
 - E. Add or remove more channels by entering the channel number or pressing CHAN up or down.

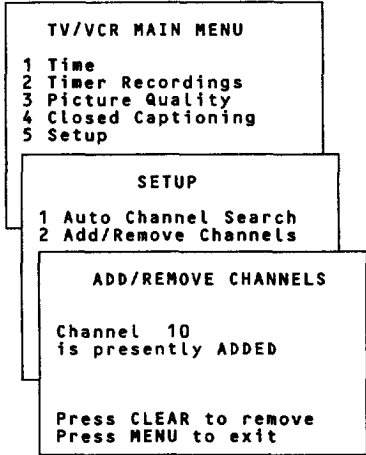

Startup

11. Select the language. (Escoge una lengua / choisissez une langue.)

This feature lets you select English or Spanish as the language for your on-screen displays.

- A. Press MENU on remote to see the TV/VCR MAIN MENU.
- B. Press 6 to display the LANGUAGE/IDIOMA/LANGUE menu. The bullet (•) indicates the language selected.
- C. Press 1 to display the menus in English.
Press 2 to display the menus in Spanish.
Press 3 to display the menus in French.

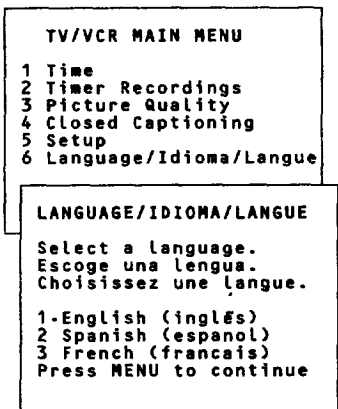

12. Select a channel and adjust the volume.

- A. Press CHAN up or down or two number buttons on the remote to select a channel.

Example: Press 0 then 2 for channel 2. The channel number is displayed.

For cable channels over 99, press and hold 1 until 1-- appears. Then press two more numbers. Example: Press and hold 1, then press 0, then press 2, for channel 102.
- B. Press VOL up or down to adjust the volume. The volume display appears.

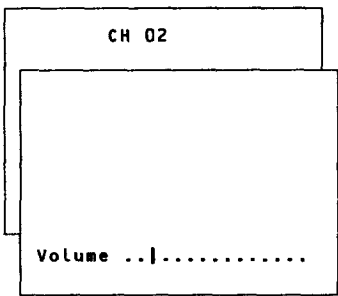

Buttons

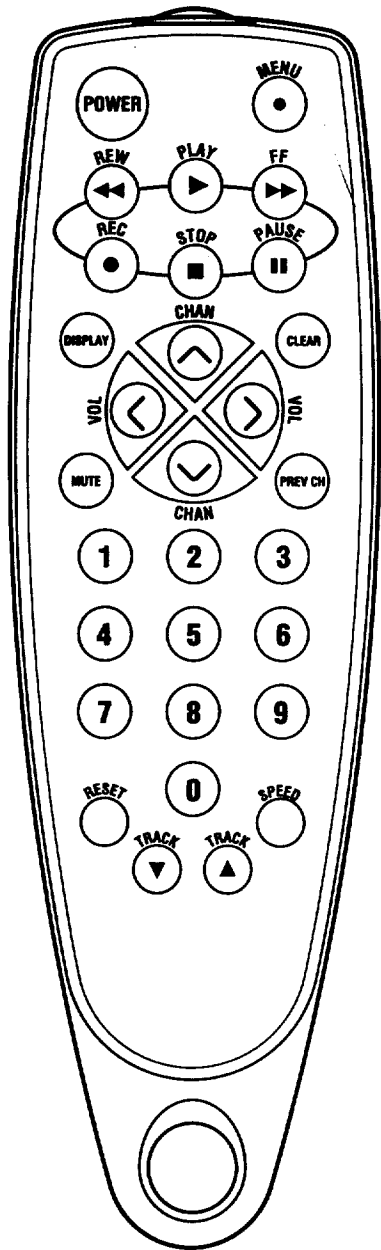

CHAN (Channel) Up or Down

Selects next higher or lower channel in channel memory.

CLEAR

Allows you to change menu entries or clear a timer recording.

Resets time counter to 0:00:00 when it is displayed.

DISPLAY

Displays TV/VCR's current status.

Displays time counter when a tape is inserted.

Removes displays.

Advances to next program during program review.

FF (Fast forward)

Fast forwards the tape when the TV/VCR is stopped.

Searches the picture in forward motion during playback.

MENU

Displays the TV/VCR MAIN MENU.

MUTE

Turns sound on or off.

Buttons

Numbers (0 through 9)

Select a channel up to 99 by pressing two numbers.

Select a cable channel over 99 by pressing and holding 1 until 1-- appears on the screen. Then press the other two numbers.

Press 00 to select the line input (VIDEO).

PAUSE

Pauses the tape during playback.

Pauses recording to prevent recording of unwanted scenes.

PLAY

Plays a tape.

POWER

Turns TV/VCR on or off.

PREV CH (Previous channel)

Switches between the last two channels.

Select one channel and then select the other using the number buttons. Press PREV CH to switch between the two channels.

REC (Record)

Starts TV/VCR recording.

Used for express recording.

RESET

Resets video functions to factory settings.

Used to reset time for wake-up timer (alarm).

REW (Rewind)

Rewinds the tape when the TV/VCR is stopped.

Searches the picture in reverse motion during playback.

SPEED (Tape Speed)

Selects a recording speed (SP or SLP).

STOP

Stops functions such as record, playback, rewind, fast forward, and pause.

TRACK (Tracking) Up or Down

Lets you manually reduce the streaks that may appear in the picture during playback.

VOL (Volume) < or >

Raises and lowers sound.

Using the TV/VCR Features

On-Screen Displays

When you change channels, adjust volume, or use a VCR feature, on-screen displays appear to let you know the status of the TV/VCR.

To Call Up On-Screen Displays

1. Press DISPLAY to display the function, channel number, time counter, date, time, and tape speed.

If you do not press DISPLAY again, these displays will time out.

2. Press DISPLAY again:
 - **No tape in TV/VCR:** Displays removed.
 - **Tape in TV/VCR:** Time counter remains on screen. Will not time out. Press DISPLAY again or eject the tape to remove the time counter.

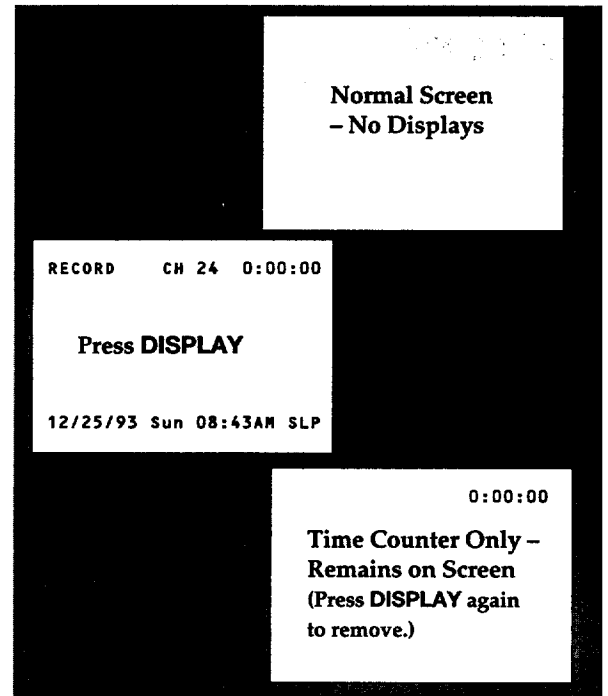

Adjust the Video

Use the PICTURE QUALITY menu to adjust the picture for your personal preference. The TV/VCR will remember the settings you select.

To Adjust Video

1. Press MENU to display the TV/VCR MAIN MENU.
2. Press 3 to display the PICTURE QUALITY menu.

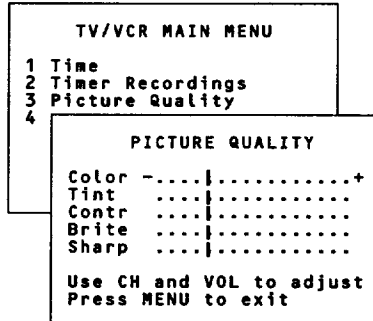

3. Press CHAN up or down to select the function you want to adjust.
 - Select Color to adjust color intensity.
 - Select Tint to adjust for natural fleshtones.
 - Select Contr (contrast) to adjust picture contrast.
 - Select Brite (brightness) to adjust picture brightness.
 - Select Sharp to adjust picture sharpness.
4. Press VOL < or > to adjust the function selected.

To Return Video to the Factory Settings

Press RESET to reset the video to the levels set at the factory.

All picture controls have been reset to factory defaults appears.

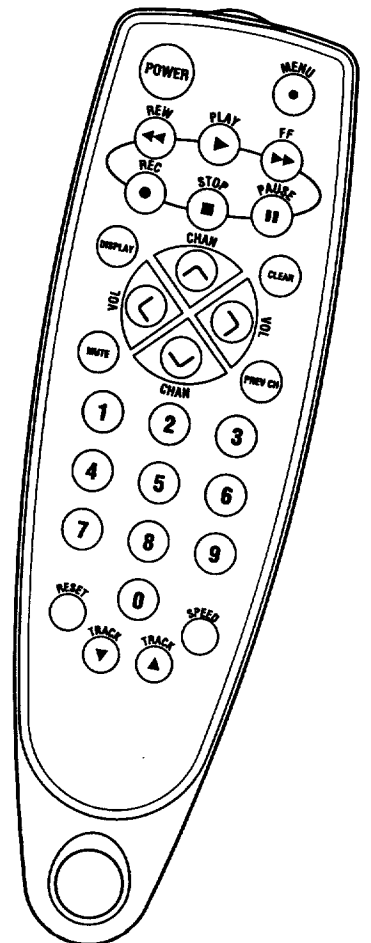

Using the TV/VCR Features

Closed Captions

Closed captioning displays the sound of a program as words on the TV screen. It is useful for the deaf, hearing impaired, or anyone who wants to watch a program without sound. If you have turned closed captioning on and it does not appear on the screen, it is not available on the channel you are watching. Check your TV program listings for CC (closed caption) broadcasts. This TV/VCR also supports two text modes used to display text sent from a TV station or cable company.

To View Closed Captions

1. Press MENU to display TV/VCR MAIN MENU.
2. Press 4 to display the CLOSED CAPTIONING menu.
3. Press 1 to change the Display.
 - There are three choices: OFF, ON, and ON WHEN MUTED.
 - Each time you press 1 the Display will change on the Closed Captioning menu screen.
4. Press 2 to select the Mode.
 - There are four choices: Caption 1, Caption 2, Text 1, and Text 2.
 - Each time you press 2 the Mode will change on the Closed Captioning menu screen.

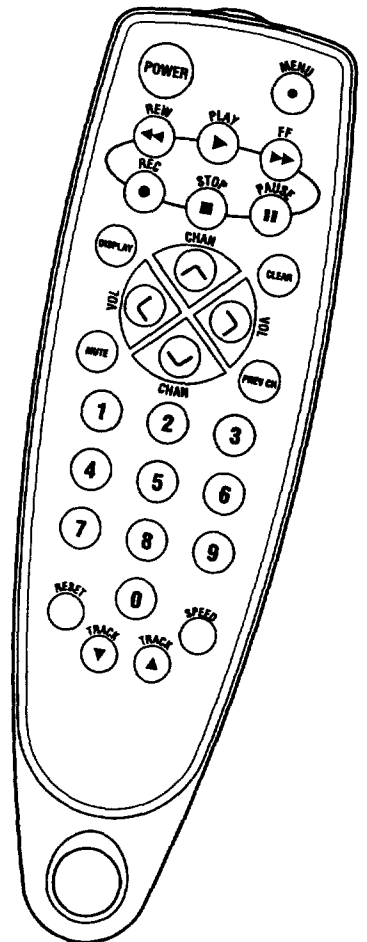
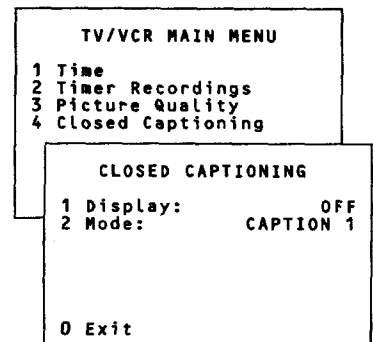

Using the TV/VCR Features

Sleep Timer

The sleep timer automatically turns the TV/VCR off after 30, 60, 90, or 120 minutes.

1. Press MENU to display the TV/VCR MAIN MENU.
2. Press 1 to display the TIME menu.
3. Press 2 to display the SLEEP TIMER screen.

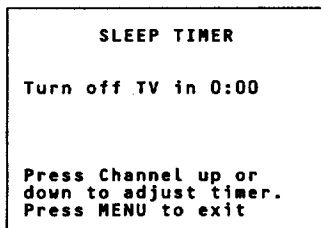

4. Press CHAN up or down to select 30, 60, 90, or 120 minutes.
5. Press MENU to exit.
Press DISPLAY to check the amount of time remaining before the TV turns off.
6. To cancel the sleep timer, display the SLEEP TIMER, and repeatedly press CHAN until 0:00 is displayed on the screen.

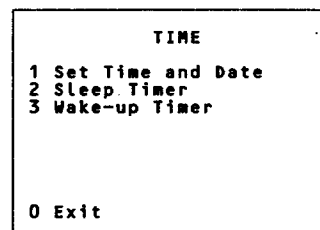
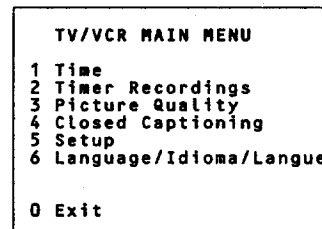

Wake-Up Timer

The timer turns the TV/VCR on at a desired time. You can set it to wake you up in the morning or remind you that a favorite program is about to start.

1. Press MENU to display the TV/VCR MAIN MENU.
2. Press 1 to display the TIME menu.
3. Press 3 to display the WAKE-UP TIMER menu.

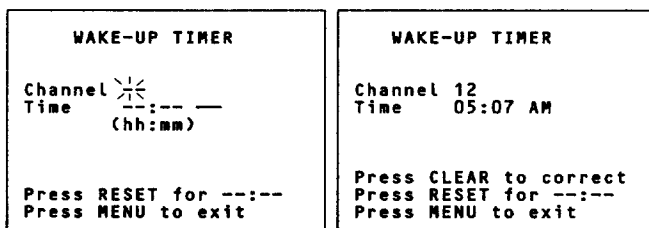

4. Use the number buttons to enter the channel number and time.
 - After you enter the time, press 1 for AM or 2 for PM.
Example: press 0, then 5, then 0, then 7, then 2, for a time of 5:07PM.
 - Press CLEAR to correct an entry or RESET to cancel the timer.
5. Press MENU to set the timer.
 - The wake-up timer will turn on the TV/VCR every day. The WAKE-UP indicator lights on the front when the wake-up timer has turned on the TV/VCR.
 - Press any button on the remote or TV/VCR to turn off the WAKE-UP indicator. If you do not press a button, the TV/VCR turns off after 60 minutes.

To Cancel the Wake-Up Timer

Follow steps 1-3 above, press RESET to cancel the timer, and then press MENU to exit.

The timer is also canceled if MENU is pressed before step 4 is completed.

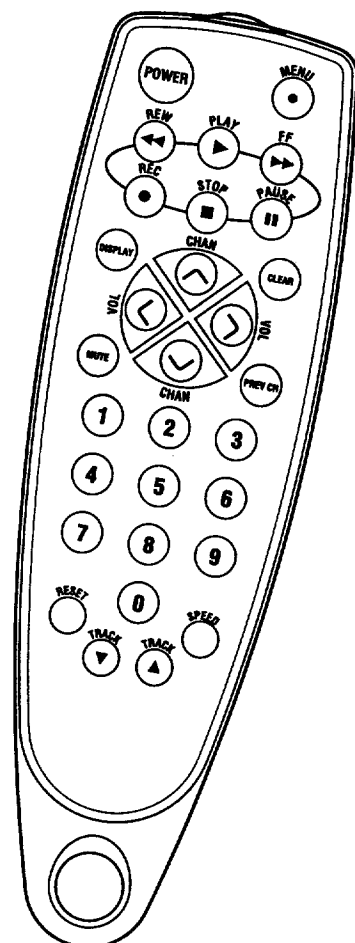

Operating Instructions

To Play a Tape

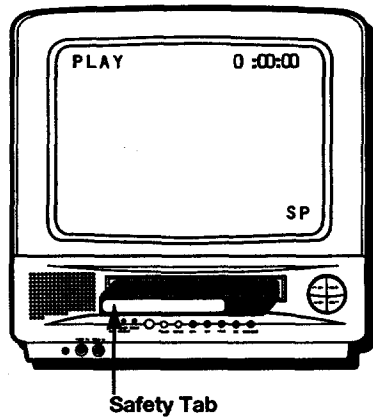

1. Insert a tape in the TV/VCR.
TV/VCR automatically turns on. The tape automatically begins playback if the safety tab on the cassette has been removed and the Auto Play feature is turned on.
2. Press PLAY, if necessary.
PLAY and the time counter appear on the screen.
3. If necessary, press TRACK up or down on the remote or CH up or down on the TV/VCR to remove any streaks from the picture.
Details are on page 14.
4. Press STOP on the remote or STOP/EJECT on the TV/VCR to stop playback.
5. Press REW. The TV/VCR will automatically rewind the tape if it reaches the end of the tape during playback. While rewinding, you can press POWER and the TV/VCR will still rewind the tape.
6. Press STOP/EJECT on the TV/VCR to eject the tape once it is completely rewound.
A cassette may be ejected with the power turned off.

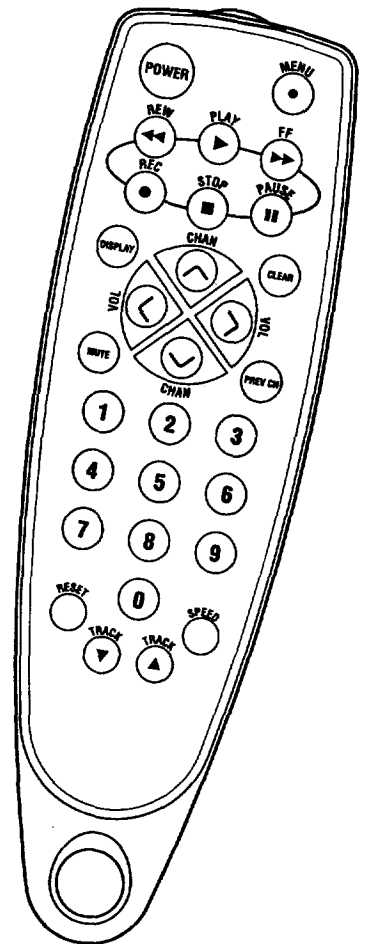

Using the Playback Features

Pause

This feature pauses the tape in action and allows you to examine the details of the scene. Pause works best for tapes recorded in the SLP speed.

1. Press PAUSE on the remote during playback to pause the action.

The TV/VCR will automatically switch from pause to stop after a few minutes to prevent tape wear.

2. Press PAUSE or PLAY to return to playback.

Picture Search

You can visually search a picture during playback. Sound is turned off during picture search. The picture is best for tapes recorded in the SLP speed.

1. During playback, press FF to search forward or REW to search in reverse.

If you start searching within five seconds of a previous search, the search speed will be slower for approximately eight seconds.

2. Press FF or REW again, or press PLAY to return to playback.

Automatic Tracking

The TV/VCR has automatic tracking which adjusts the picture when playing a tape that was recorded on another VCR. Automatic tracking is turned on whenever a tape is inserted or the TV/VCR's power is turned on.

Manual Tracking

Occasionally, you may need to manually adjust tracking on a tape recorded on a different VCR or camcorder. Tracking is used when playing a tape. It has no effect during recording.

- When streaks or snow appear in the picture during normal playback or slow motion, press TRACK up or down on the remote or CH up or down on the TV/VCR for the best possible picture.
- To turn automatic tracking back on, press and hold both of the CH buttons on the front of the TV/VCR.

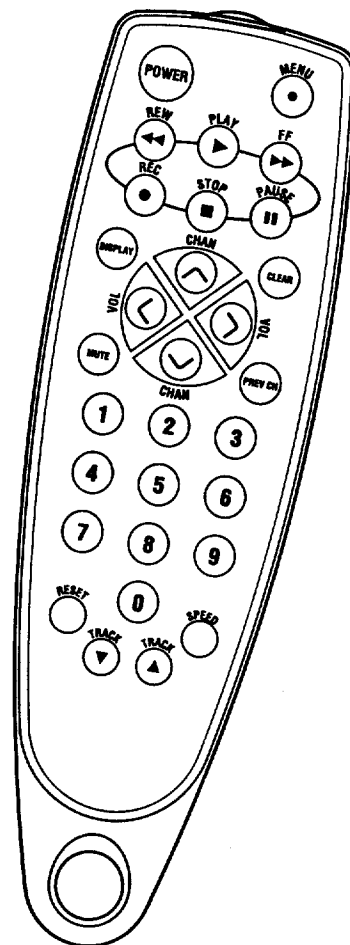

Using the Playback Features

Time Counter

The time counter helps locate the beginning or end of programs you taped. The time counter automatically resets to 0:00:00 whenever a tape is inserted, or you can press CLEAR when the time counter is displayed.

For example, if a 30-minute program was recorded at the beginning of the tape and you wanted to record another program after it, you would:

1. Insert the pre-recorded tape. Press STOP. Make sure the tape is rewound.
2. Press DISPLAY twice to display the time counter.

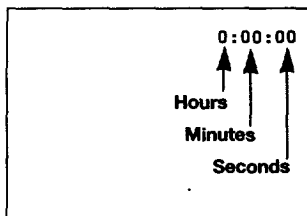

3. Press FF to fast forward the tape until the time counter reads 0:30:00.

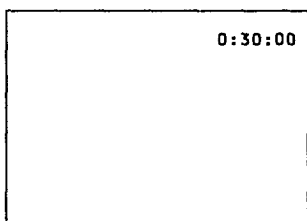

This is the approximate end of the program and you can begin recording at this spot.

4. Press DISPLAY again or eject the tape to remove the time counter from the screen.

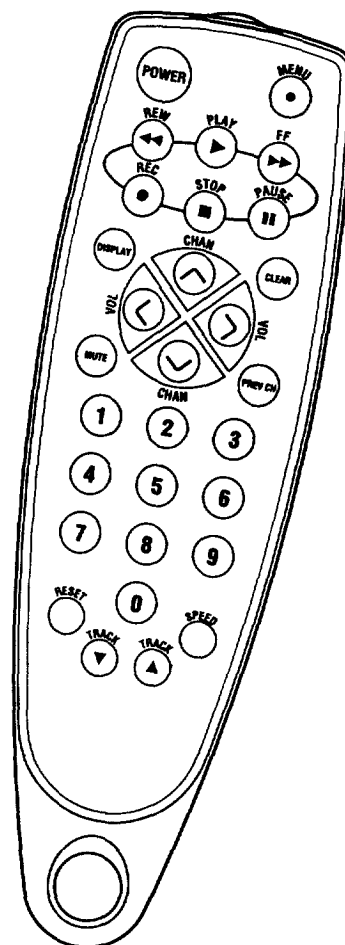

Using the Playback Features

Auto Play Feature

This feature enables the TV/VCR to automatically start playing a tape when it is inserted. (The safety tab on the tape must be removed.)

1. Press MENU to display the TV/VCR MAIN MENU.
2. Press 5 to display the SETUP menu.
3. Press 4 to change the Auto Play setting.

The Auto Play feature is set to ON at the factory.

 - Select ON if you want a tape with its safety tab removed to start playing automatically.
 - Select OFF if you do not want a tape with its safety tab removed to start playing automatically.

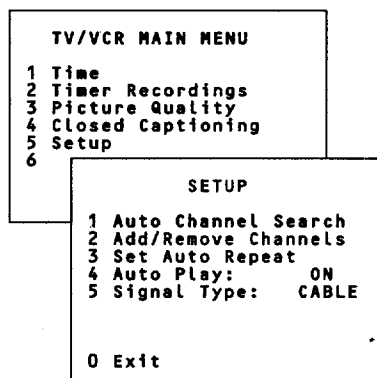

Auto Repeat Feature

This feature tells the TV/VCR to play a tape (or part of a tape) continuously. The TV/VCR will automatically rewind the tape, or a selected portion of the tape, and play it repeatedly.

1. Using REW, FF, or PLAY, go to the place on the tape that you want to be the beginning of the section that automatically repeats. Reset the time counter to 0:00:00 by pressing DISPLAY, then CLEAR.
2. Using FF or PLAY, go to the place on the tape that you want to be the end of the section that plays continuously. Remember the numbers on the time counter. (2:55 is the end time for AUTO REPEAT in the example to the right.)
3. Press MENU to display the TV/VCR MAIN MENU.
4. Press 5 to display the SETUP menu.
5. Press 3 to display the AUTO REPEAT menu.
6. Using the number buttons, enter the amount of time you want the tape to repeat (the number from Step 2). In the example at right, the section that the TV/VCR will automatically repeat is 2:55 – two hours, 55 minutes long.
7. The REPEAT indicator on the front of the TV/VCR will light when you activate the Auto Repeat feature.

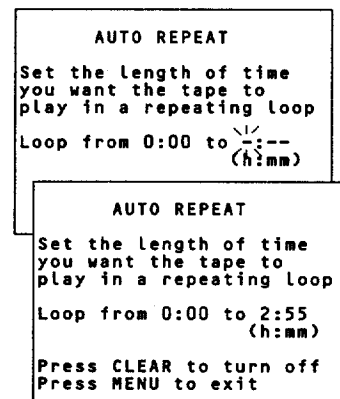

To Cancel Auto Repeat

Press MENU, 5, 3, and CLEAR.

Recording Features

Recording Speeds

Press **SPEED** to select a recording speed.

- **SP (Standard Play)** gives the best quality recording. That is why most pre-recorded, rental tapes are recorded in SP. Fewer programs can be recorded on the tape. Special effects in playback are not recommended in SP.
- **SLP (Super Long Play)** gives three times the recording time of tapes recorded in SP. Special effects such as pause and picture search work best in this speed.

Cassette	Recording Time	
	SP	SLP
T-120	2Hr	6Hr
T-160	2Hr 40Min	8Hr

Recording Pause

This feature allows you to prevent recording short passages of unwanted material.

- Press **PAUSE** during recording to stop and start recording.
The TV/VCR will automatically switch from pause to stop after a few minutes to prevent tape wear.

Types of Recordings

Your TV/VCR provides different types of recording. These types are explained in the following sections:

Basic Recording – Operating Instructions

Recording While You're Away

Timer Recording

Express Recording

Copying and Editing Tapes

Basic Recording – Operating Instructions

To Make a Recording

1. Insert a tape with safety tab in place.
2. Press **SPEED** to select a recording speed.
The tape speed indicator appears.
3. Select the channel to be recorded. If recording from the **AUDIO/VIDEO IN** jacks, press **00** to select the line input (**VIDEO**).
The channel number or **VIDEO** appears.
4. Press **REC** to begin recording.
The indicator in the **REC** button on the front of the TV/VCR turns on during recording and **RECORD** appears on the screen.
5. Press **STOP/EJECT** on the TV/VCR or **STOP** on the remote to stop recording.

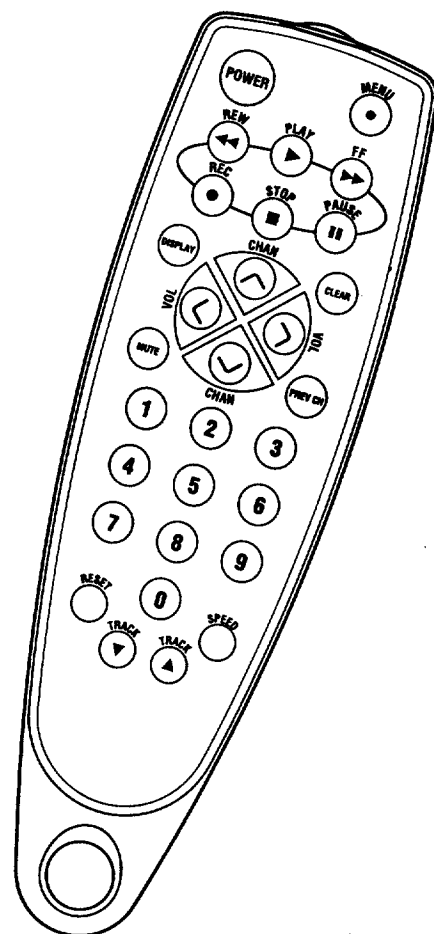

Recording While You're Away (Timer Recording)

Timer recording lets you program the TV/VCR to record up to eight different programs within a one year period. Before setting the timer, make sure that the clock is set correctly.

Setting a Timer Recording

1. Press MENU to display the TV/VCR MAIN MENU.
2. Press 2 to display the TIMER RECORDINGS menu.
3. Press 1 to Create a New Program.
4. Press 1, 2, 3, or 4 to select the type of program.
 - 1 One time — single program recorded once.
 - 2 Daily — program recorded at same time every day.
 - 3 Weekdays — program recorded at same time Monday through Friday.
 - 4 Weekly — program recorded at same time once a week.
5. Press number buttons to enter the channel number, start time including AM or PM, end time, and start date of the recording. Just follow the on-screen prompts.
 - If recording from the AUDIO/VIDEO IN jacks, press 00 to select the line input (VIDEO) instead of a channel.

Press CLEAR to correct an entry.
6. Press SPEED to select a recording speed.
7. Press MENU to save your program.
8. Repeat steps 3 – 6 for additional programs.
9. Insert a tape with safety tab intact before the recording is to begin.

The TIMER REC indicator lights in the TV/VCR's front panel.

If you turn the TV/VCR off, the TIMER REC indicator will flash if there is no cassette in the TV/VCR or the safety tab is missing from the cassette.
10. If using a cable box, turn it on and tune it to the channel you want to record before time for the recording to begin.

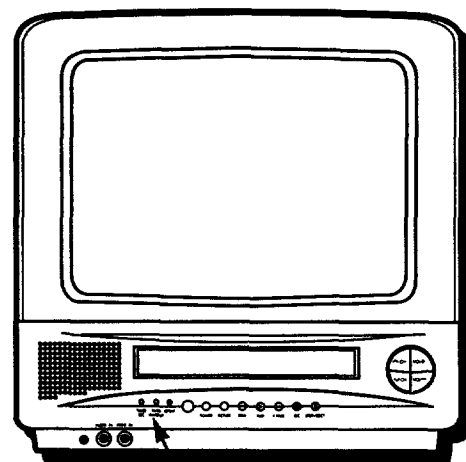
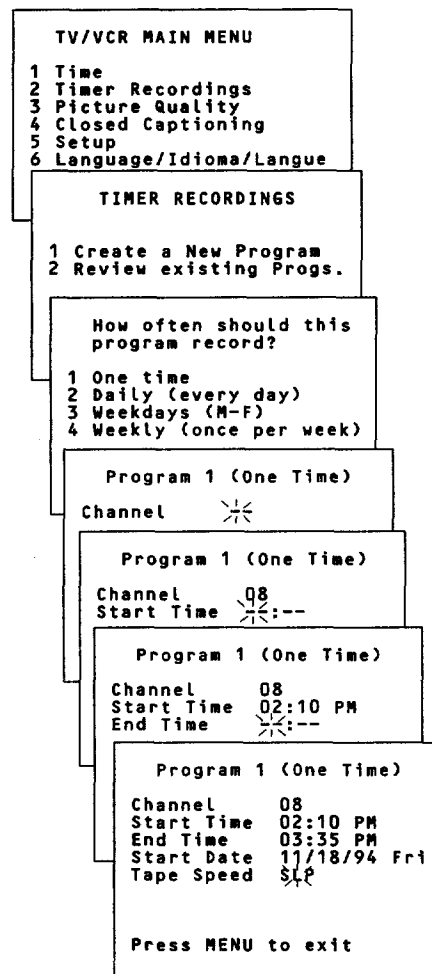

TIMER RECORDER Indicator

Recording While You're Away (Timer Recording)

Checking or Clearing Timer Recordings

1. Press MENU on the remote to display the TV/VCR MAIN MENU.
2. Press 2 to display the TIMER RECORDINGS menu.
3. Press 2 to Review existing progs.
4. Press DISPLAY to review the next program in sequence.
5. Press CLEAR to erase a program.

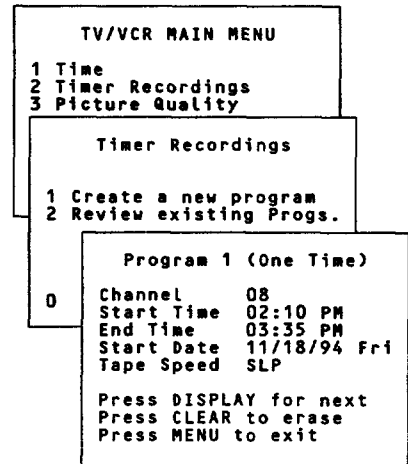

Stopping A Timer Recording

1. Press STOP/EJECT on the TV/VCR or STOP on the remote.

A timer program in progress will be stopped. Only today's recording of a daily, weekdays, or weekly program is cancelled. The daily, weekdays, or weekly program remains in the timer.

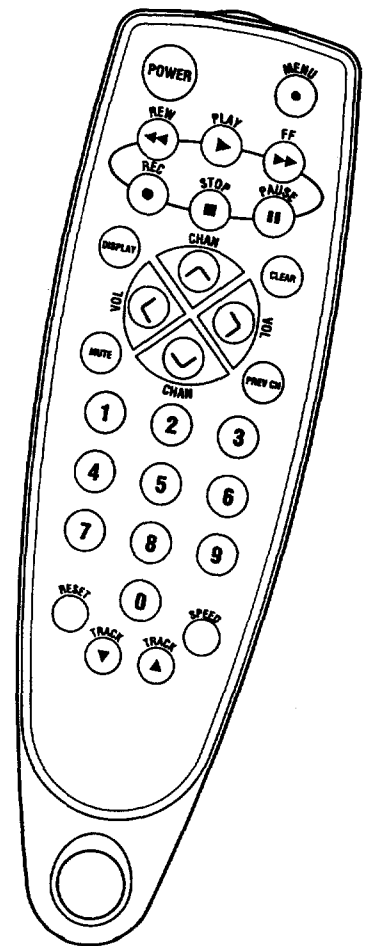

Recording While You're Away (Express Recording)

Operating Instructions

1. Insert a tape with safety tab in place. The TV/VCR will turn on.
2. Select the channel to be recorded.
If recording from the AUDIO/VIDEO IN jacks, press 00 to select the line input (VIDEO).
3. Press SPEED to select a recording speed. You can also change the speed of an express recording in progress.
4. Press REC to activate recording.
5. Press REC repeatedly until the desired amount of recording time is displayed. Each press of REC increases the time — 30 minutes up to tape end.

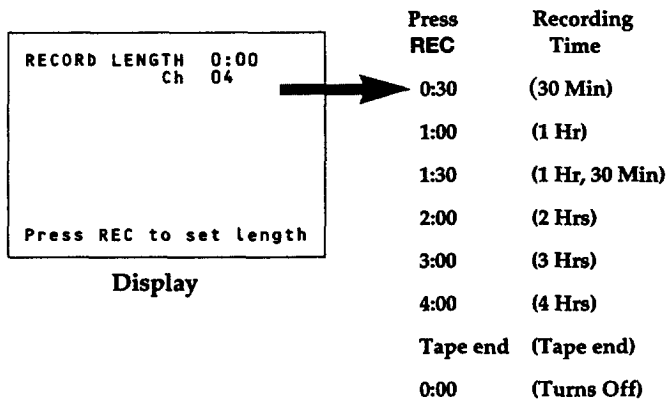

The TIMER REC indicator on the TV/VCR's front panel will light during express recording.

During express recording, press REC to display the time remaining on the screen. Press REC again to increase the recording time.

Stopping an Express Recording in Progress

Press STOP/EJECT on the TV/VCR or STOP on the remote to stop the express recording.

— OR —

Repeatedly press REC until RECORD LENGTH: 0:00 appears.

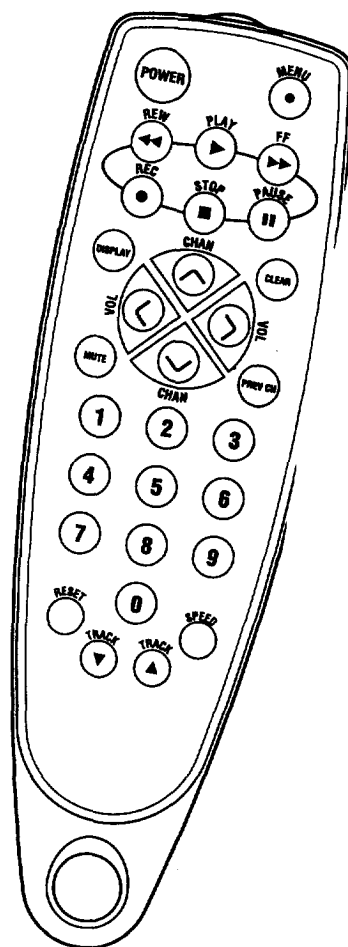

Copying and Editing Tapes

Operating Instructions (Refer to hookup on page 24.)

Caution: The unauthorized recording of television programs and other materials may infringe the rights of others.

Use another VCR or camcorder as the playback VCR and the TV/VCR as the recording VCR.

1. Turn on the VCR or camcorder and the TV/VCR.
2. Press 00 on TV/VCR's remote to select the line input (VIDEO).
3. Insert the tape you want to copy into the playback VCR or camcorder. Insert a blank tape with safety tab intact into the TV/VCR.
4. Start the playback VCR or camcorder playing. If the tape was not recorded on the playback VCR, streaks may appear and you may need to adjust tracking. When you reach the place you want to begin copying, place the playback VCR or camcorder in play pause.
5. Press REC, then PAUSE, on the TV/VCR's remote.
6. Press PAUSE on both the VCR or camcorder and the TV/VCR's remote at the same time to begin copying the tape.
7. Edit out segments that you do not want to copy by pressing PAUSE on the TV/VCR's remote to stop copying the tape. Then, locate the next segment you want to copy on the playback VCR or camcorder by using FF, REW, and PLAY. Press PAUSE on the playback VCR or camcorder. Press PAUSE at the same time on both the VCR or camcorder and the TV/VCR's remote to resume copying.
8. Press STOP on both the VCR or camcorder and the TV/VCR's remote when you are finished.

Remember to press CHAN up or down on the TV/VCR's remote for normal TV viewing on the TV/VCR.

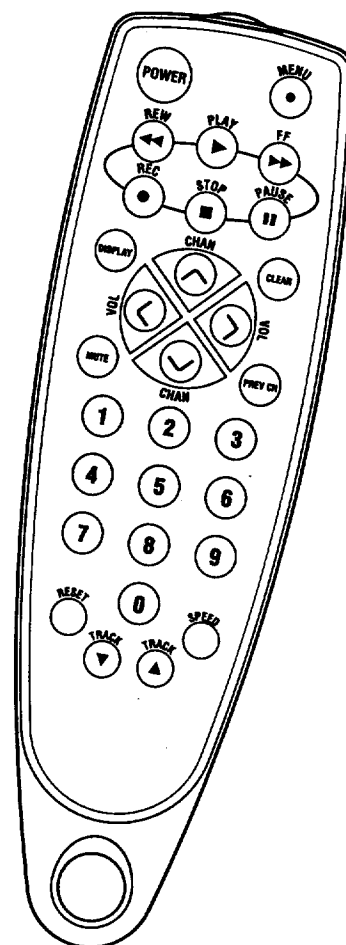
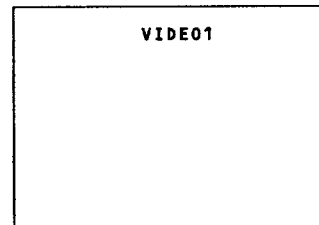

Location of Controls — Front Panel

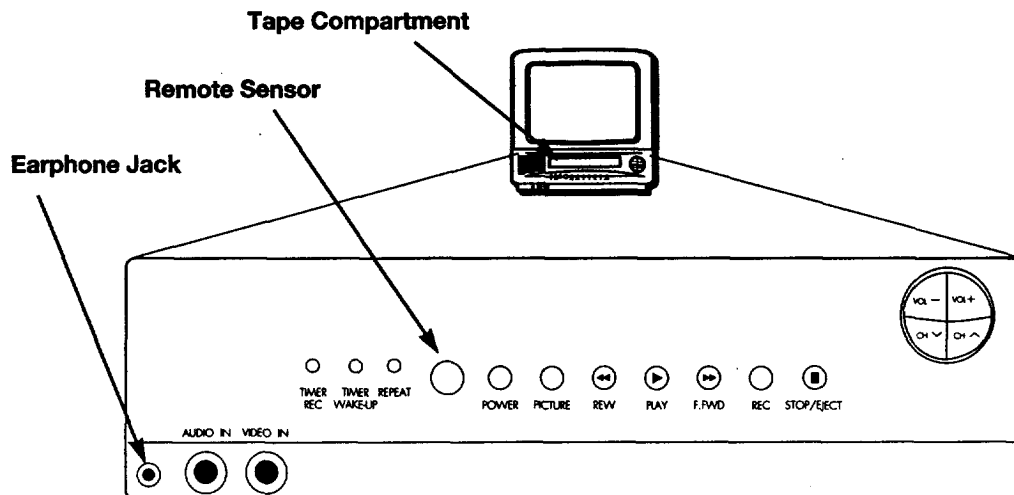

Audio IN and Video IN Jacks

Receives audio signals from another component, like a VCR or camcorder when it is connected to these jacks.

To select these jacks, press **)** to display VIDEO.

CH ^ and v (Channel up and down)

Selects next higher or lower channel in the TV/VCR's channel memory.

Used for manual tracking when a tape is playing.

Earphone Jack

Connect an earphone (not supplied) to this jack.

F.FWD (Fast Forward)

Fast forwards the tape when the VCR is stopped. Searches the picture forward during playback.

PICTURE

Displays the PICTURE QUALITY menu. See page 8.

PLAY

Plays a tape.

POWER

Turns the TV/VCR on or off. The indicator in the button is lit when the power is on.

REC (Record)

Press to start TV/VCR recording. The indicator in the button lights during recording.

Remote Sensor

Remote Sensor

Receives signals from the remote. Aim remote at this sensor with no objects between them.

REPEAT Indicator

Lights during auto repeat.

REW (Rewind)

Rewinds the tape when the TV/VCR is stopped. Searches the picture in reverse during playback.

STOP/EJECT

Stops normal functions — such as record, play, rewind, fast-forward, or pause.

Press when a tape is stopped to eject the cassette.

TIMER REC Indicator

Lights when a timer program has been set and a cassette with safety tab in place is in the TV/VCR.

Flashes when a timer recording has been set and the TV/VCR is turned off with no cassette inserted, a cassette with no safety tab has been inserted, or there has been a power interruption.

TIMER WAKE UP Indicator

Lights when the wake-up timer turns on the TV/VCR.

VOL + and - (Volume up and down)

Raises and lowers the sound.

Back Panel

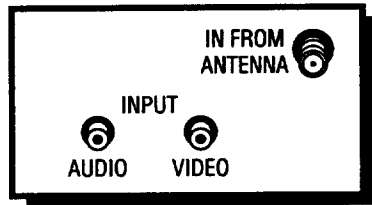

IN FROM ANTENNA Jack

Receives the signal from an antenna or cable system.

VIDEO and AUDIO IN Jacks

Receives signals from another component, such as a VCR or camcorder, when it is connected to these jacks.

To select these jacks, press 00 to display VIDEO.

Hooking Up the TV/VCR

Choosing a Hookup

Answer the questions to choose the hookup for your TV/VCR.

1. How do you receive your TV signals?

Choose one answer from below.

- A. Supplied dipole antenna – Turn to page 22.
- B. Rabbit ears (set-top) and/or bowtie antenna – Turn to page 22.
- C. Outside antenna – Turn to page 22.
- D. Cable System – Go to question 2.

2. What type of Cable-TV system* do you have?

Choose one answer from below.

- A. Cable without a box – Turn to page 22.
- B. Cable box to unscramble all channels – Turn to page 23.
- C. Cable box to unscramble only premium channels, such as HBO, Showtime, Cinemax, etc. – Turn to page 23.

*You may need to contact your local cable company for assistance.

Optional Hookup

To hook up a VCR or camcorder for copying tapes — Turn to page 24.

Connect Supplied Antenna, Antenna, or Cable System Without a Cable Box

A. Supplied Antenna

Follow these steps to connect the supplied antenna to your TV/VCR. Do not connect this antenna if you plan to connect a different type of indoor or outdoor antenna or cable system.

1. Insert the antenna base into the slot on the back of your TV/VCR.
2. Connect the twin-lead ends of the antenna to the screw terminals of the supplied antenna adapter.
3. Connect the antenna adapter to the VHF/UHF connector on the back of the TV/VCR.
4. Plug in the TV/VCR's power cord.
5. Turn to page 2 for "Setting Up the TV/VCR."

Adjust the length and position of the antenna rods for the best reception.

- For viewing VHF channels, extend the rods fully.
- For UHF viewing, shorten the rods.

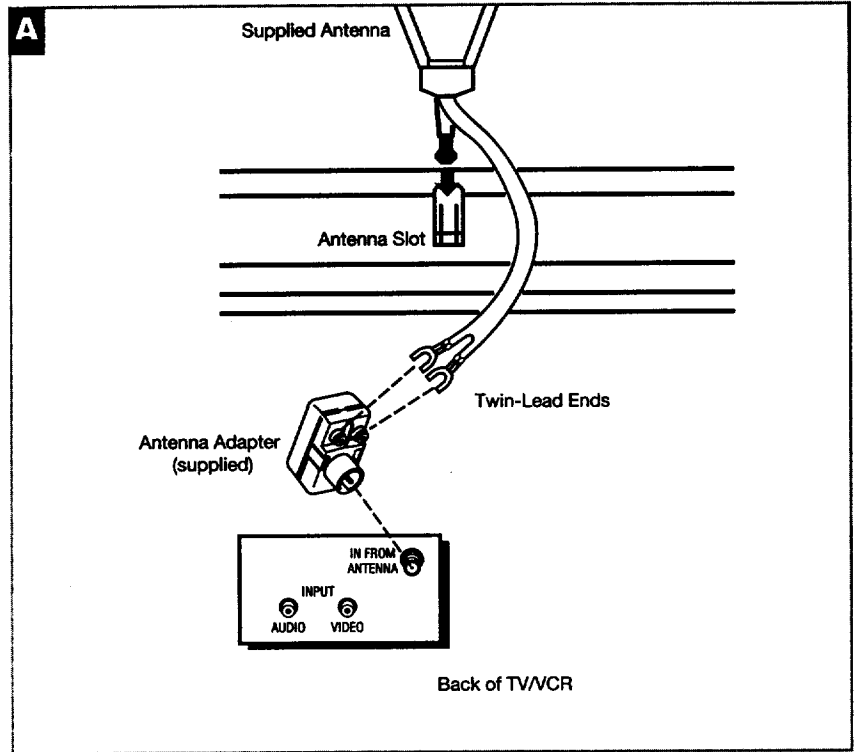

B. Antenna or Cable System Without a Cable Box

1. Connect as shown.
This connection may require additional accessories not provided.
2. Plug in TV/VCR's power cord.
3. Turn to page 2 for "Setting Up the TV/VCR."

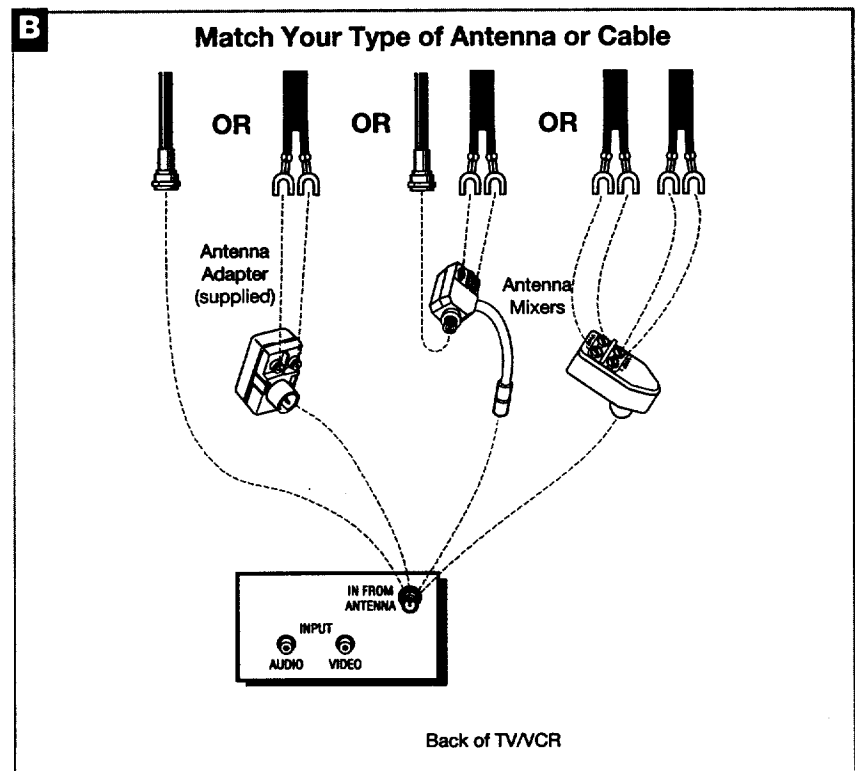

Connect a Cable System With a Cable Box

A. Cable Box Required to Unscramble all Channels

1. Connect as shown.
This connection may require additional accessories not provided.
2. Plug in power cords of TV/VCR and cable box.
3. Turn to page 2 for "Setting Up the TV/VCR."

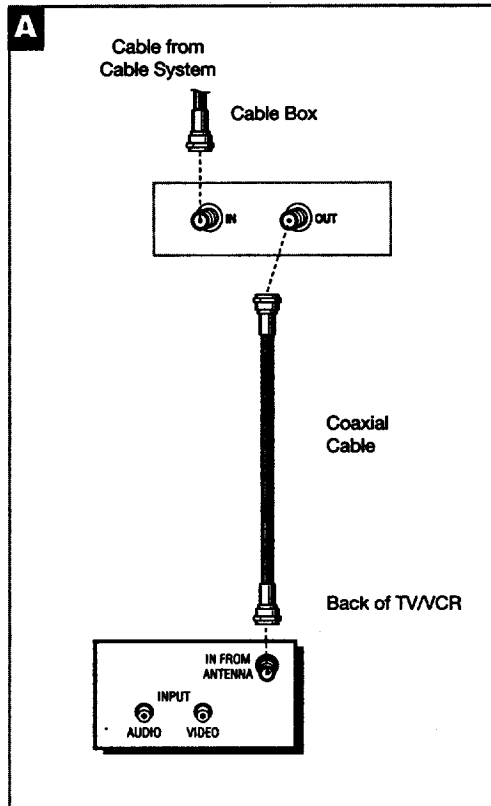

B. Cable Box Required to Unscramble Only Premium Channels

1. Connect as shown.
This connection requires additional accessories not provided.
2. Plug in power cords of TV/VCR and cable box.
3. Operation
Place the A-B switch in the B position to watch premium channels. Place the A-B switch in the A position to watch other channels when cable box is not needed.
4. Turn to page 2 for "Setting Up the TV/VCR."

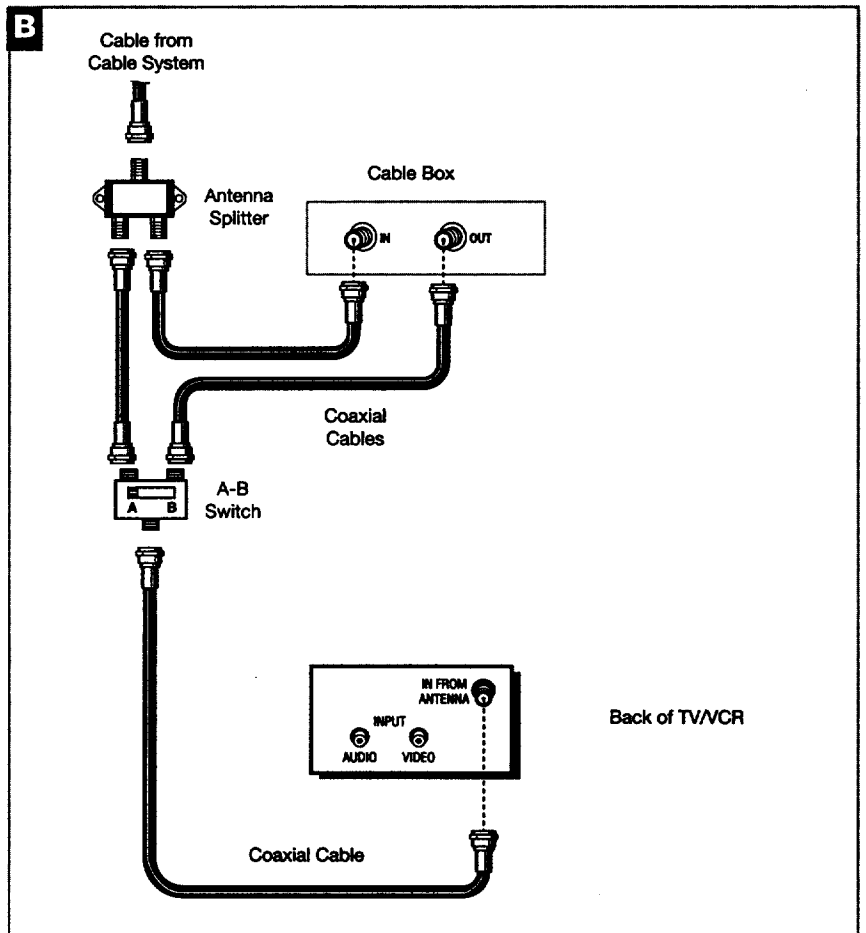

Connect a VCR or Camcorder for Copying Tapes

A. VCR for Copying Tapes

1. Connect as shown.

This connection requires additional accessories not provided.

2. Plug in power cords of VCR and TV/VCR.

3. Turn to page 19 for "Copying and Editing Tapes."

Press 00 on the remote to select the line (audio/video) input on the TV/VCR to receive the signal from the VCR.

If your VCR has stereo AUDIO OUT jacks, connect the audio cable to the jack labeled MONO. If neither jack is labeled MONO, you may need a Y-adapter to hear both channels.

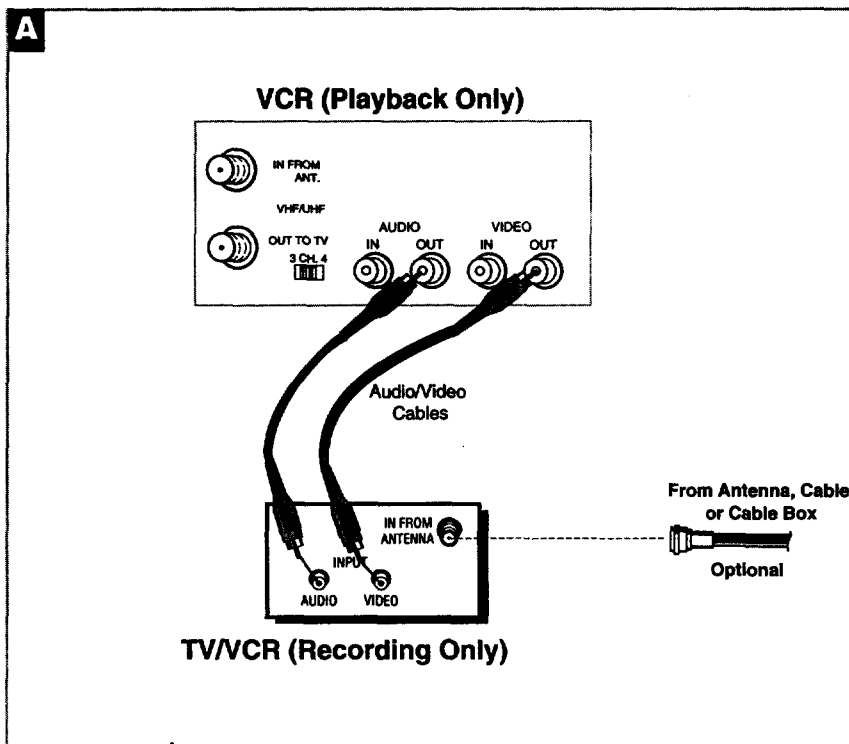

B. Camcorder for Copying Tapes

1. Connect as shown.

This connection requires additional accessories not provided.

2. Plug in TV/VCR's power cord.

3. Turn to page 19 for "Copying and Editing Tapes."

Press 00 on the remote to select the line (audio/video) input on the TV/VCR to receive the signal from the camcorder.

If your camcorder has stereo AUDIO OUT jacks, you may need a Y-adapter to hear both channels.

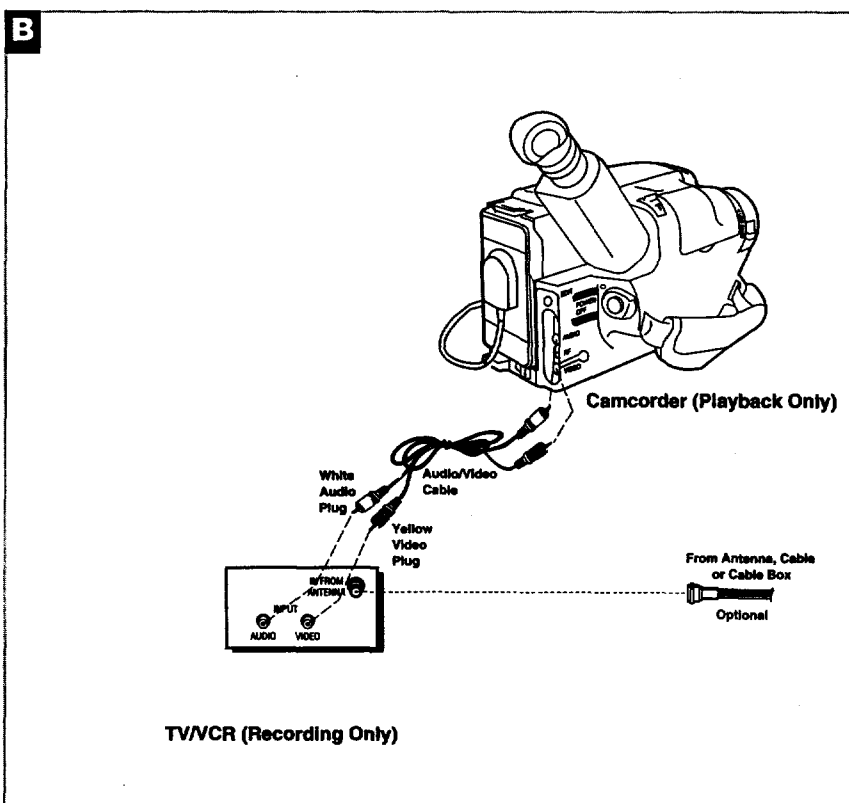

Caution: The unauthorized recording of television programs and other materials may infringe the rights of others.

Cleaning the TV/VCR

Use a soft cloth or dusting attachment of your vacuum cleaner to dust your TV/VCR. Remove dust from the ventilation holes of the cabinet.

Plastic surfaces are easily scratched and can be marred by alcohol and various solvents. Avoid excessive use of oil-based furniture polishes since the materials used in the cabinet will accumulate more dust. We recommend using a non-abrasive, anti-static cleaner and polisher.

Specifications

Picture Tube	13-inch measured diagonal 90° deflection
Format:	VHS
Record/Playback System:	Video: 2-Head Audio Track: One
Video Signal System:	EIA standard: NTSC color
Antenna:	75-ohm external VHF/UHF combined antenna terminal
Tuner:	USA: 181 channel tuning capability* (125 cable channels) Canada: 178 channel tuning capability* (122 cable channels)
Type:	AutoProgramming frequency synthesis
Power Requirement:	120V AC, 60 Hz
Power Consumption:	69 watts
Dimensions:	15.8 inches high (403 mm) 14.8 inches wide (376 mm) 17 inches deep (432 mm)
Weight:	28 pounds (12.7 kg)
Operating Temperature Range:	+41°F to +104°F
Operating Humidity Range:	10% to 75%

* Check your cable company's compatibility requirements.

Trouble Checks

Sometimes problems can be easily solved by checking a few basic things. Check below before you call for help or take your TV/VCR to an Authorized RCA VCR Servicenter.

Trouble	Here's what to try:
No power	<ul style="list-style-type: none"> • Plug TV/VCR into an operating outlet. • Check connections.
TV/VCR does not respond to remote	<ul style="list-style-type: none"> • Aim remote at TV/VCR's remote sensor with no objects between them. • Change batteries.
Poor or no picture for normal TV viewing	<ul style="list-style-type: none"> • Switch to an active channel. • Check antenna connections. If using supplied dipole, try adjusting rods. • Check video adjustments. <i>See page 8.</i> • Make sure the line input is not selected. Select a channel with the CHAN buttons.
No sound	<ul style="list-style-type: none"> • Press VOL up to increase sound. • Sound has been muted. Press MUTE on remote or VOL up.
Snow or streaks in picture or no picture during playback	<ul style="list-style-type: none"> • Check tape — it may be worn out or of poor quality. Try another tape. • Some snow/streaks are normal during search and pause. • Press one of the TRACK buttons on the remote or CH up or down on the TV/VCR to move the streaks up or down and out of the picture.
Will not record or play	<ul style="list-style-type: none"> • No cassette in TV/VCR. • Eject and re-insert cassette. • Broken tape — try another cassette. • Safety tab removed from cassette — TV/VCR will not record. • TV/VCR is in pause mode. Press PAUSE on the remote.
Cannot insert or eject tape	<ul style="list-style-type: none"> • Insert cassette with window facing up and safety tab facing out. • To remove cassette, TV/VCR must be connected to working outlet. • Turn POWER off and then on before trying to insert or remove cassette.
Time counter not working	<ul style="list-style-type: none"> • Press DISPLAY on remote to display time counter on screen. <i>See page 8.</i> • The time counter does not advance during unrecorded portions of tape. When an unrecorded segment of tape is encountered, the time counter will hold its count until recorded material is detected again. • A minus (-) will appear in front of the time if you rewind the tape farther back than a counter reading of 0:00:00.
Rewind does not operate	<ul style="list-style-type: none"> • Tape already rewound.
Timer recording not made or wrong program recorded	<ul style="list-style-type: none"> • Program entered incorrectly (wrong channel or times). • Cable box was not turned on at time recording was to begin. • Power interruption. TIMER indicator flashes on front of TV/VCR. • Check to see if time and date are correct — including AM/PM. • Program exceeded tape's length or tape was not rewound beforehand. • No tape in TV/VCR, or cassette ejected if safety tab broken off.

Trouble Checks

Trouble	Here's what to try:
Clock shows incorrect time or date	<ul style="list-style-type: none"> • Power interruption. TIMER indicator flashes on front of TV/VCR. • Clock was not set accurately (check AM/PM and date). • Time zone or daylight savings time information incorrect. <i>See page 4.</i>
TV/VCR makes noise when stopped	<ul style="list-style-type: none"> • TV/VCR is removing tape from heads. This is normal. The head cylinder inside the TV/VCR will continue to rotate for a few minutes after you put the VCR in the stop mode.
Will not auto channel search active channels correctly	<ul style="list-style-type: none"> • Check antenna or cable connections.
Cannot see closed captions on screen	<ul style="list-style-type: none"> • Closed caption function must be set to on. <i>See page 9.</i> • Station may not be broadcasting closed captions.
Box appears on screen	<ul style="list-style-type: none"> • A text feature has been selected. <i>See page 9</i>
TIMER indicator flashing on front of TV/VCR	<ul style="list-style-type: none"> • Power interruption. Check clock. <i>See page 4.</i> • Timer program set and TV/VCR turned off with no cassette or cassette with no safety tab inserted. <i>See page 16.</i>
Tape plays over and over	<ul style="list-style-type: none"> • Auto repeat play turned on. <i>See page 14.</i>
Tape starts playing automatically	<ul style="list-style-type: none"> • Auto play feature turned on. <i>See page 14.</i>
TV/VCR turns off automatically	<ul style="list-style-type: none"> • Sleep timer turned on. Press POWER to turn TV/VCR back on.
TV/VCR turns on automatically	<ul style="list-style-type: none"> • Wake up timer (alarm) turned on. <i>See page 10.</i>
Rainbow effect appears on TV/VCR picture	<ul style="list-style-type: none"> • TV/VCR swiveled while it was operating. Unplug the TV/VCR, swivel it into place, wait one hour, and then plug it back in.
Cannot record one program while watching a different program	<ul style="list-style-type: none"> • TV/VCR only has one tuner. Only one program can be watched and recorded at the same time.

Limited Warranty

What your warranty covers:

- Any defect in material or workmanship.

For how long after your purchase:

- Ninety days for labor charges.
- One year for parts.
- Two years for picture tube.

(The warranty period for rental units begins with the first rental or 45 days from date of shipment to the customer, whichever comes first.)

What we will do:

- Pay any Authorized RCA VCR Servicenter the labor charges to repair your TV/VCR.
- Pay any Authorized RCA VCR Servicenter for the new or, at our option, rebuilt replacement parts required to repair your TV/VCR.

How you get service:

- Take your TV/VCR to any Authorized RCA VCR Servicenter. To identify your nearest Authorized RCA VCR Servicenter, ask your dealer, look in the Yellow Pages, or call 1-800-336-1900.
- Show the service technician your evidence of purchase date.
- Pick up your TV/VCR when repairs are completed.

What your warranty does not cover:

- Customer instruction. (Your Owner's Manual clearly describes how to install, adjust, and operate your TV/VCR. Any additional information should be obtained from your Dealer.)
- Installation and related adjustments.
- Signal reception problems not caused by your TV/VCR.
- Damage from misuse or neglect.
- Cleaning of video/audio heads.
- Remote control batteries.
- A TV/VCR that has been modified or incorporated into other products or is used for institutional or other commercial purposes.
- A TV/VCR purchased or serviced outside the USA.
- Acts of God, such as but not limited to lightning charge.

Product Registration:

- Please complete and mail the Product Registration Card packed with your TV/VCR. It will make it easier to contact you should it ever be necessary. The return of the card is not required for warranty coverage.

How state law relates to this warranty:

- This warranty gives you specific legal rights, and you also may have other rights that vary from state to state.

If you purchased your TV/VCR outside the United States:

- This warranty does not apply. Contact your dealer for warranty information.

Index

- Accessories, Included 2
- ADD/REMOVE CHANNELS Menu . 5
- Adding Channels to Memory 5
- Adjusting the Video 8
- Adjusting Volume 5
- Antenna System, Connecting 22
- AUDIO/VIDEO IN Jacks 19,21,24
- AUTO CHANNEL SEARCH Menu . 4
- Auto Play Feature 14
- AUTO PLAY Screen 14
- Auto Repeat Feature 14
- AUTO REPEAT Menu 14
- Automatic Tracking 12
- Back Panel Controls 21
- Base, Attaching 3
- Basic Recording 15
- Batteries, Installing in Remote 2
- Brite (Brightness) Function 8
- Buttons, Remote Control 6-7
- Cable System (No Cable Box),
Connecting 22
- Cable System with Cable Box,
Connecting 23
- Camcorder, Connecting to
TV/VCR 24
- Captions, Closed 9
- Cautions i
- CC DISPLAY and MODE Menus . . 9
- CHAN and CH Buttons . . . 5,6,15,20
- Channel Memory, Programming . . 4
- Channel, Selecting 5
- Checking a Timer Recording 17
- Choosing a Hookup 21
- Cleaning the TV/VCR 25
- CLEAR Button 4,6,10,13,17
- Clearing a Timer Recording 17
- Clock Setting, Automatic or Manual . 4
- CLOSED CAPTIONING Menu . . . 9
- Closed Captions 9
- Color Function 8
- Contents 1
- Contr (Contrast) Function 8
- Controls, Back Panel 21
- Controls, Front Panel 20
- Controls, Remote 6-7
- Copying Tapes 19
- Daily Programs, Recording 16
- Date, Setting 4
- Design Specifications 25
- Dipole Antenna, Connecting 22
- DISPLAY Button 6,8,13,17
- Displays, On-Screen 8
- Editing Tapes 19
- Erase Protection 11
- Escoge una Lengua 5
- Express Recording 18
- Factory Settings, Reset 8
- Fastening Strip 3
- Features, Playback 11-14
- Features, Recording 15-19
- Features, TV/VCR 8-10
- FF (Fast Forward)
Button 6,12,13,19,20
- First-Time Operation 2-5
- Front Panel Controls 20
- Home Antenna System,
Connecting 22
- Hookups
Antenna 22
- Cable System With Cable
Box for All Channels 23
- Cable System With Cable Box
for Premium Channels 23
- Cable System With No
Cable Box 22
- Camcorder to Copy Tapes . . 24
- Supplied Antenna 22
- VCR to Copy Tapes 24
- IDIOMA/LANGUAGE Menu 5
- Important Information i
- Included Accessories 2
- Information, Important i
- Language for Displays 5
- LANGUAGE/IDIOMA Menu 5
- Limited Warranty 28
- Location of Controls 6-7,20-21
- Manual Tracking 12
- MENU Button . . 3,4,5,6,8,9,10,14,16,17
- Moving TV/VCR While
Operating 3,27
- MUTE Button 6
- Note to Cable TV Installer i
- Number Buttons . . . 4,6-7,10,14,16,19
- On-Screen Displays 8
- One-Time Program, Recording . . 16
- Operation
Play a Tape 11
- Express Recording 18
- Record a Program 15
- Program Channel Memory . . . 4
- Timer Record 16
- Video, Adjust 8
- Set the Clock 4
- Set the Sleep Timer 10
- Set the Wake-up Timer 10
- PAUSE Button 6-7,12,19
- Pause During Playback 12
- Pause During Recording 15
- PICTURE QUALITY Menu 8
- Picture Search 12
- PLAY Button 6-7,11,12,20
- Playback
Auto Play 14
- Features 11-14
- Pause 12
- Play a Tape 11
- Repeat 14
- Position TV/VCR 3
- POWER Button and
Indicator 3,6-7,11,20
- Problem Solving 26-27
- Product Registration Card i
- Programming Channel Memory . . 4
- PROGRAMMING Menu 16,17
- Rainbow Effect 3,27
- REC (Record) Button and
Indicator 6-7,15,16,18,20
- Recording
Basic 15
- Express 18
- Features 15
- Pause 15
- Speeds and Chart 15
- Timer 16-17
- Registration Card i
- Remote Batteries, Installing 2
- Remote Control Buttons 6-7
- Remote Sensor 20
- Removing Channels from Memory . 5
- REPEAT Indicator 14,20
- RESET Button 6-7,8,10
- Resetting Video to Factory Settings . 8
- REW (Rewind) Button . 6-7,11,12,19,20
- Safety Tab 11,15-19
- Searching, Visual 12
- Selecting a Channel 5
- Selecting a Language for Displays . 5
- Sensor, Remote 20
- Setting the Date and Time 4
- Setting Up the TV/VCR 2-5
- SETUP Menu 4,5,14
- Sharp Function 8
- Sleep Timer 10
- SLP and SP Speeds 15
- Solving Problems 26-27
- Specifications 25
- SPEED Button 6-7,15,16-18
- Speeds, Recording 15
- Start Up 2-5
- STOP Button 6-7,11,13,16-18
- STOP/EJECT Button . . 11,13,16-18,20
- Stopping a Timer Recording 17
- Stopping an Express Recording . . 18
- Strip, Fastening 3
- Swivel Base, Attaching 3
- Tapes, Copying and Editing 19
- Text Mode, Closed Captioning . . . 9
- Time Counter 13
- TIME Menu 4,10
- Time, Setting 4
- TIMER Indicator 16,18,20
- Timer Recording 16-17
- Tint Function 8
- TRACKING Buttons 6-7,11,12
- Tracking, Automatic and Manual . 12
- Trouble Checks 26-27
- Turn on TV/VCR 3
- TV/VCR MAIN
MENU 4,5,8,9,10,14,16,17
- TV/VCR Setup 2-5
- Types of Recordings 15
- VCR, Connecting to TV/VCR 24
- VHF/UHF Antenna
Connector 21-23
- Video, Adjusting 8
- VIDEO/AUDIO IN Jacks 19,21,24
- Video, Reset to Factory Settings . . 8
- Video Settings 8
- VOL (Volume) Buttons . . . 5,6-7,8,20
- Volume, Adjusting 5
- WAKE-UP Indicator 10,20
- Warnings i
- Warranty, Limited 28
- Weekdays (M-F), Recording . . . 16
- Weekly Program, Recording . . . 16

For your nearest Authorized Servicenter
call toll-free in the U.S.A.

1-800-336-1900

Canadian Consumers —
Your toll-free numbers are.

English: 1-800-522-0338

French: 1-800-522-0445

If your TV/VCR needs service, please contact your dealer or
the nearest servicenter from the yellow pages. Please do not
send any products to the Indianapolis address listed in this
manual or on the carton. This will only add delays in service
for your product.

 **THOMSON CONSUMER ELECTRONICS**

**10330 N Meridian Street
Indianapolis, IN 46290**

©1996 Thomson Consumer Electronics, Inc.

Trademark(s)® Registered

Marca(s) Registrada(s)

Printed in Japan

Part Number 20511220