

**HITACHI**

**PROJECTION COLOR TV**

**50EX20B**

**60EX38B**

**OPERATING GUIDE**



**IMPORTANT SAFEGUARDS**

**2-5**

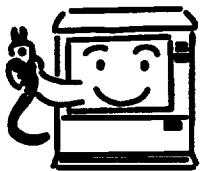

**FIRST TIME USE**

**6-13**



**THE REMOTE CONTROL**

**14-22**

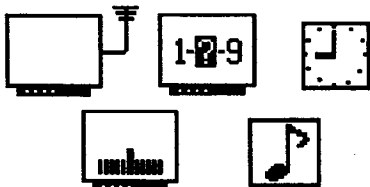

**EASY GRAPHIC GUIDE**

**23-37**



**USEFUL INFORMATION  
INDEX**

**38-43**





---



## IMPORTANT

Your new HITACHI PROJECTION TV incorporates a host of features designed to give you excellent performance if you follow the instructions in this manual. We recommend that you read the following instructions and "IMPORTANT SAFEGUARDS" notice before turning on your TV set for the first time.

Follow all warnings and instructions marked on this television receiver.

	<b>CAUTION</b> RISK OF ELECTRIC SHOCK DO NOT OPEN			The lightning flash with arrowhead symbol, within an equilateral triangle, is intended to alert the user to the presence of uninsulated "dangerous voltage" within the product's enclosure that may be of sufficient magnitude to constitute a risk of electric shock to persons.
CAUTION: TO REDUCE THE RISK OF ELECTRIC SHOCK, DO NOT REMOVE COVER (OR BACK) NO USER-SERVICEABLE PARTS INSIDE. REFER SERVICING TO QUALIFIED SERVICE PERSONNEL.				The exclamation point within an equilateral triangle is intended to alert the user to the presence of important operating and maintenance (servicing) instructions in the literature accompanying the appliance.

**WARNING:**  
**TO PREVENT FIRE OR SHOCK HAZARD, DO NOT EXPOSE THIS TELEVISION SYSTEM TO RAIN OR MOISTURE.**

- NOTE:**
- There are no user serviceable parts inside the receiver.
  - Model number and serial number are indicated on back side of the set.



**CAUTION:** Adjust only those controls that are covered in the instructions, as improper changes or modifications not expressly approved by HITACHI could void the user's authority to operate the TV.

### POWER SOURCE:

This HITACHI projection TV is designed to operate on 120 volts 60 Hz, AC household current. Insert power cord into a 120 volt 60 Hz outlet.

**TO PREVENT ELECTRIC SHOCK, DO NOT USE THE TELEVISION'S PLUG WITH AN EXTENSION CORD, RECEPTACLE, OR OTHER OUTLET UNLESS THE BLADES AND GROUND TERMINAL CAN BE FULLY INSERTED TO PREVENT BLADE EXPOSURE.**

**NEVER CONNECT THE TV TO 50 Hz, DIRECT CURRENT, OR ANYTHING OTHER THAN THE SPECIFIED VOLTAGE.**

**NOTE:** This television receiver will display television closed captioning, (  or  ), in accordance with paragraph 15.119 of the FCC rules.

 **CAUTION:** Never remove the back cover of the set as this can expose you to very high voltages and other hazards. If the set does not operate properly, unplug the set and call your dealer or service shop.

# SAFETY TIPS



## IMPORTANT SAFEGUARDS

### CAUTION:

- Read all of these instructions
- Save these instructions for later use.
- Follow all warnings and instructions marked on the television receiver.

### SAFETY POINTS YOU SHOULD KNOW ABOUT YOUR HITACHI TELEVISION RECEIVER

Our reputation has been built on the quality, performance, and ease of service of HITACHI television receivers.

Safety is also foremost in our minds in the design of these units. To help you operate these products properly, this section illustrates safety tips which will be of benefit to you. Please read it carefully and apply the knowledge you obtain from it to the proper operation of your HITACHI television receiver.

Please fill out your warranty card at once and mail it to HITACHI. This will enable HITACHI to notify you promptly in the improbable event that a safety problem should be discovered in your model of product.

#### FOR YOUR PERSONAL SAFETY

1. This television set is equipped with a polarized alternating-current line plug (a plug having one blade wider than the other). This plug will fit into the power outlet only one way. This is a safety feature. If you are unable to insert the plug fully into the outlet, try reversing the plug. If the plug should still fail to fit, contact your electrician to replace your obsolete outlet. Do not defeat the safety purpose of the polarized plug.



2. When the power cord or plug is damaged or frayed, unplug this television set from the wall outlet and refer servicing to qualified service personnel.



3. Do not overload wall outlets and extension cords as this can result in fire or electric shock.



4. Do not allow anything to rest on or roll over the power cord, and do not place the TV where the power cord is subject to traffic or abuse. This may result in a shock or fire hazard.



5. Do not attempt to service this television set yourself as opening or removing covers may expose you to dangerous voltage or other hazards. Refer all servicing to qualified service personnel.



6. Never push objects of any kind into this television set through cabinet slots as they may touch dangerous voltage points or short out parts that could result in a fire or electric shock. Never spill liquid of any kind on the television set.



7. If the television set has been dropped or the cabinet has been damaged, unplug this television set from the wall outlet and refer servicing to qualified service personnel.

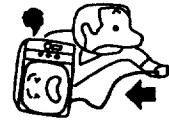

8. If liquid has been spilled into this television set, unplug it from the wall outlet and refer service to qualified service personnel.



9. Do not subject your television set to impact of any kind. Be particularly careful not to damage the picture tube surface.



10. Unplug this television set from the wall outlet before cleaning. Do not use liquid cleaners or aerosol cleaners. Use a damp cloth for cleaning.



- 11-1. Do not place this television set on an unstable cart, stand, or table. The television set may fall, causing serious injury to a child or an adult, and serious damage to the appliance. Use only with a cart or stand recommended by the manufacturer, or sold with the television set. Wall or shelf mounting should follow the manufacturer's instructions, and should use a mounting kit approved by the manufacturer.



- 11-2. An appliance and cart combination should be moved with care. Quick stops, excessive force, and uneven surfaces may cause the appliance and cart combination to overturn.



#### PROTECTION AND LOCATION OF YOUR SET

12. Do not use this television set near water, for example, near a bathtub, washbowl, kitchen sink, or laundry tub, in a wet basement, or near a swimming pool, etc.



- Never expose the set to rain or water. If the set has been exposed to rain or water, unplug the set from the wall outlet and refer to servicing personnel.



13. Choose a place where light (artificial or sunlight) does not shine directly on the screen.



14. Avoid dusty places, since accumulated dust inside the chassis may cause failure of the set when high humidity persists.

15. The set has slots, or openings in the cabinet for ventilation purposes, to provide reliable operation of the receiver, and to protect from overheating. These openings must not be blocked or covered.



- Never cover the slots or openings with cloth or other material.



- Never block the bottom ventilation slots of the set by placing it on a bed, sofa, rug, etc.



- Never place the set near or over a radiator or heat register.



- Never place the set in a "built-in" enclosure, unless proper ventilation is provided.



# SAFETY TIPS

## PROTECTION AND LOCATION OF YOUR SET

16-1. If an outside antenna is connected to the television set, be sure the antenna system is grounded so as to provide some protection against voltage surges and built up static charges, Section 810 of the National Electrical Code, NFPA No. 70-1975, provides information with respect to proper grounding of the mast and supporting structure,

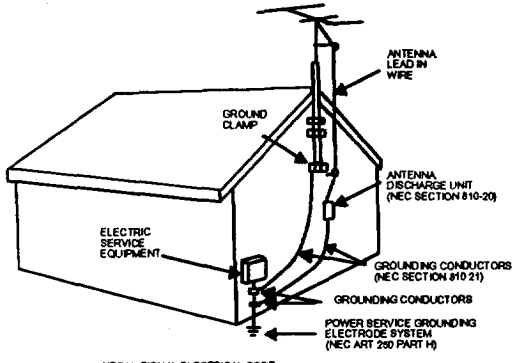

EXAMPLE OF ANTENNA GROUNDING AS PER NATIONAL ELECTRICAL CODE INSTRUCTIONS

grounding of the lead-in wire to an antenna discharge unit, size of grounding conductors, location of antenna discharge unit, connection to grounding electrode, and requirements for the grounding electrode.

16-2. Note to CATV system installer:  
(Only for the television set with CATV reception)  
This reminder is provided to call the CATV system installer's attention to Article 820-40 of the NEC that provides guidelines for proper grounding and, in particular, specifies that the cable ground shall be connected to the grounding system of the building, as close to the point of cable entry as practical.

17. An outside antenna system should not be located in the vicinity of overhead power lines or other electrical lights or power circuits, or where it can fall into such power lines or circuits. When installing an outside antenna system, extreme care should be taken to keep from touching such power lines or circuits as contact with them might be fatal.

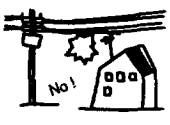

18. For added protection for this television set during a lightning storm, or when it is left unattended and unused for long periods of time, unplug it from the wall outlet and disconnect the antenna. This will prevent damage due to lightning and power-line surges.



## OPERATION OF YOUR SET

19. This television set should be operated only from the type of power source indicated on the marking label. If you are not sure of the type of power supply at your home, consult your television dealer or local power company. For television sets designed to operate from battery power, refer to the operating instructions.



20. If the television set does not operate normally by following the operating instructions, unplug this television set from the wall outlet and refer servicing to qualified service personnel. Adjust only those controls that are covered in the operating instructions as improper adjustment of other controls may result in damage and will often require extensive work by a qualified technician to restore the television set to normal operation.



21. When going on a holiday: If your television set is to remain unused for a period of time, turn the television set "off" and unplug it from the wall outlet.



## IF THE SET DOES NOT OPERATE PROPERLY

22. If you are unable to restore normal operation by following the detailed procedure in your operating instructions, do not attempt any further adjustment. Unplug the set and call your dealer or service technician.



23. Whenever the television set is damaged or fails, or a distinct change in performance indicates a need for service, unplug the set and have it checked by a professional service technician.

24. It is normal for some TV sets to make occasional snapping or popping sounds, particularly when being turned on or off. If the snapping or popping is continuous or frequent, unplug the set and consult your dealer or service technician.



## FOR SERVICING AND MODIFICATION

25. Do not use attachments not recommended by the television set manufacturer as they may cause hazards.



26. When replacement parts are required, be sure the service technician has used replacement parts specified by the manufacturer that have the same characteristics as the original part. Unauthorized substitutions may result in fire, electric shock, or other hazards.

27. Upon completion of any service or repairs to the television set, ask the service technician to perform routine safety checks to determine that the television is in safe operating condition.





# WARNING

Continuous on-screen displays such as video games, stock market quotations, computer generated graphics, and other fixed (non-moving) patterns can cause permanent damage to projection television receivers. Such "PATTERN BURNS" constitute misuse and are NOT COVERED by your Hitachi Factory Warranty.

When using the Picture-in-Picture function, the sub-picture should not be left permanently in one corner of the screen or a "pattern burn" may develop over a long period of time.

This projection television receiver was intended mainly for the private viewing of programs broadcast by TV stations and cable companies and programs from other video sources. Public viewing may require prior authorization from the broadcaster or owner of the video program.



## ACCESSORIES

Check to make sure you have the following accessories before disposing of the packing material.

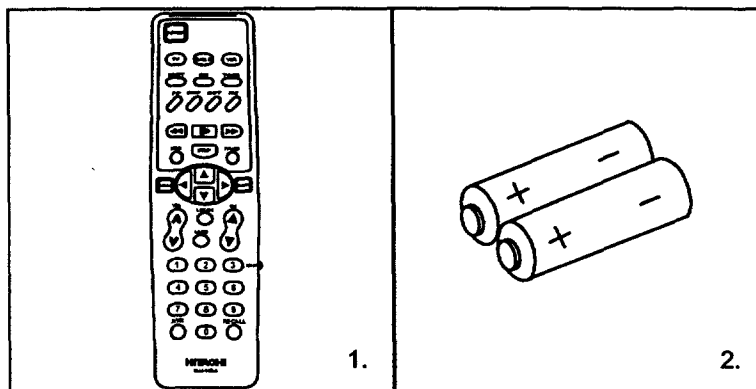

1. Remote Control Unit CLU-415UI (Part No. HL00224)
2. Two "AA" size, 1.5V batteries (For Remote Control Unit)

## REMOTE CONTROL BATTERY INSTALLATION AND REPLACEMENT

1. Open the battery cover of the remote transmitter by pushing the notched part of the cover with your fingers.
2. Insert two new "AA" size batteries or equivalent for the remote. When replacing old batteries, push them towards the springs and lift them out.
3. Match the (+) and (-) marks in the battery compartment.
4. Replace the cover.

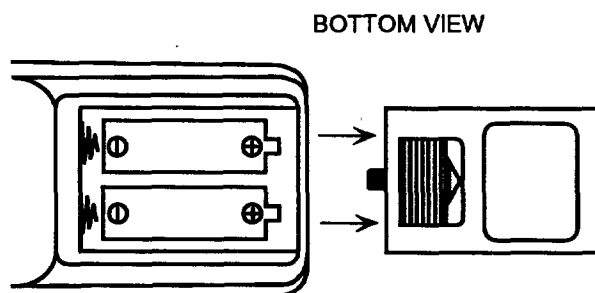



# HOW TO SET UP YOUR NEW HITACHI PROJECTION TV

## ANTENNA

Unless your TV is connected to a cable TV system or to a centralized antenna system, a good outdoor color TV antenna is recommended for the best performance. However, if you are located in an exceptionally good signal area that is free from interference and multiple image ghosts, an indoor antenna may be sufficient.

## LOCATION

Select an area where sunlight or bright indoor illumination will not fall directly on the picture screen. Also, be sure that the location selected allows a free flow of air to and from the perforated back cover of the set.

To avoid cabinet warping, cabinet color changes, and increased chance of set failure, do not place the TV where temperatures can become excessively hot. For example, in direct sunlight or near a heating appliance, etc.

## VIEWING

The major benefit of the HITACHI Projection Television is its large viewing screen. To see this screen at its best, test various locations in the room to find the best spot for viewing. The drawings give several suggestions.

The best picture is seen by sitting directly in front of the TV and about 10 to 18 feet from the screen. Picture brightness decreases as the viewer moves to the left or right of the receiver.

During daylight hours, reflections from outside light may appear on the screen. If so, drapes or screens can be used to reduce the reflection or the TV can be located in a different section of the room.

If the TV's audio output will be connected to a Hi-Fi system's external speakers, the best audio performance will be obtained by placing the speakers equidistant from each side of the receiver cabinet and as close as possible to the height of the picture screen center. For best stereo separation, place the external speakers at least 4 feet from the side of the TV. Place the surround speakers to the side or behind the viewing area. Differences in room sizes and acoustical environments will require some experimentation with speaker placement for best performance.

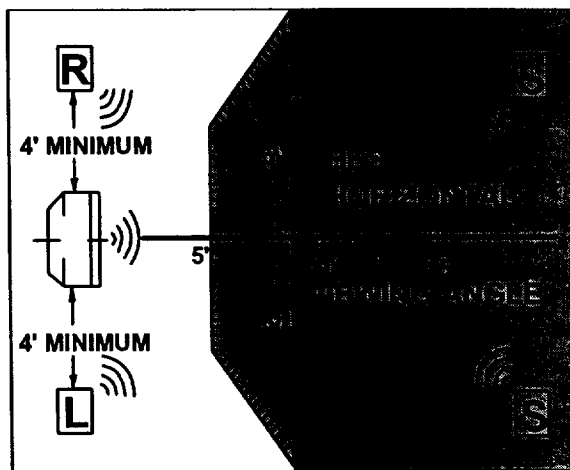
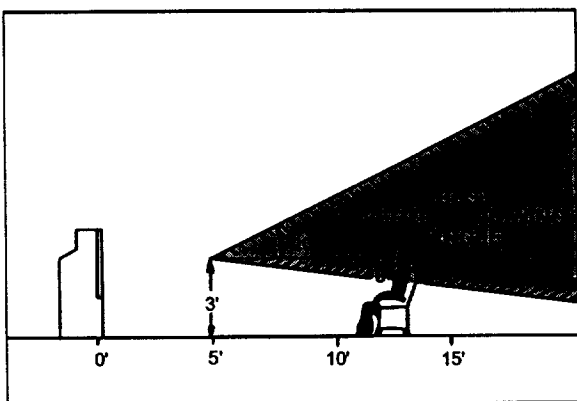

**CAUTION:** The magnetic field of external speakers may cause the TV picture to distort if the speakers are placed too close to the television. Move the speakers away from the TV until there is no picture distortion.



## HOOKUP CABLES AND CONNECTORS

Most video/audio connections between components can be made with shielded video and audio cables that have phono connectors. For best performance, video cables should use 75-ohm coaxial shielded wire. Cables can be purchased from most stores that sell audio/video products. Below are illustrations and names of common connectors. Before purchasing any cables, be sure of the output and input connector types required by the various components. Also make sure the cables are the correct length.

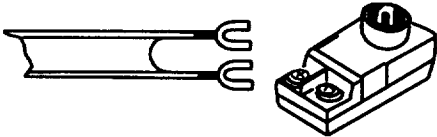

### 300-Ohm Twin Lead Connector

This outdoor antenna cable must be connected to an antenna adaptor (300-Ohm to 75-Ohm).



### "F" Type 75-Ohm Coaxial Antenna Connector

For connecting RF signals (antenna or cable TV) to the antenna jack on the television.



### Phono Connector

Used on all standard video and audio cables which connect to inputs and outputs located on the Television's rear jack panels.



### S-Video (Super Video) Connector

This connector is used on camcorders, VCR's, and laser disc players with an S-Video feature in place of the standard video cable to produce a high-quality picture.

## ANTENNA CONNECTIONS TO REAR JACK PANEL

## REAR OF TV

### VHF (75-Ohm) antenna/CATV(cable TV)

When using a 75-Ohm coaxial cable system, connect the outdoor antenna or CATV coaxial cable to the VHF/UHF 75 Ohm terminal.

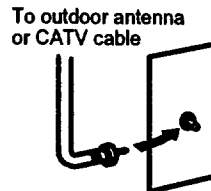

### VHF (300-Ohm) antenna/UHF antenna

When using a 300-Ohm twin lead from an outdoor antenna, connect the VHF or UHF antenna leads to screws of the VHF or UHF adaptor. Plug the adaptor into the antenna terminal on the TV.

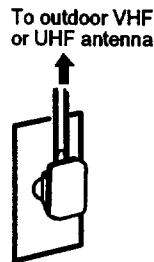

### When both VHF and UHF antennas are connected

Attach an optional antenna cable mixer to the TV antenna terminal, and connect the cables to the antenna mixer. Consult your dealer or service store for the antenna mixer.

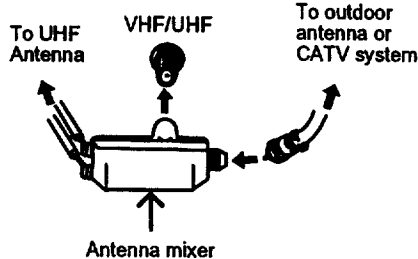



## FRONT PANEL CONTROLS

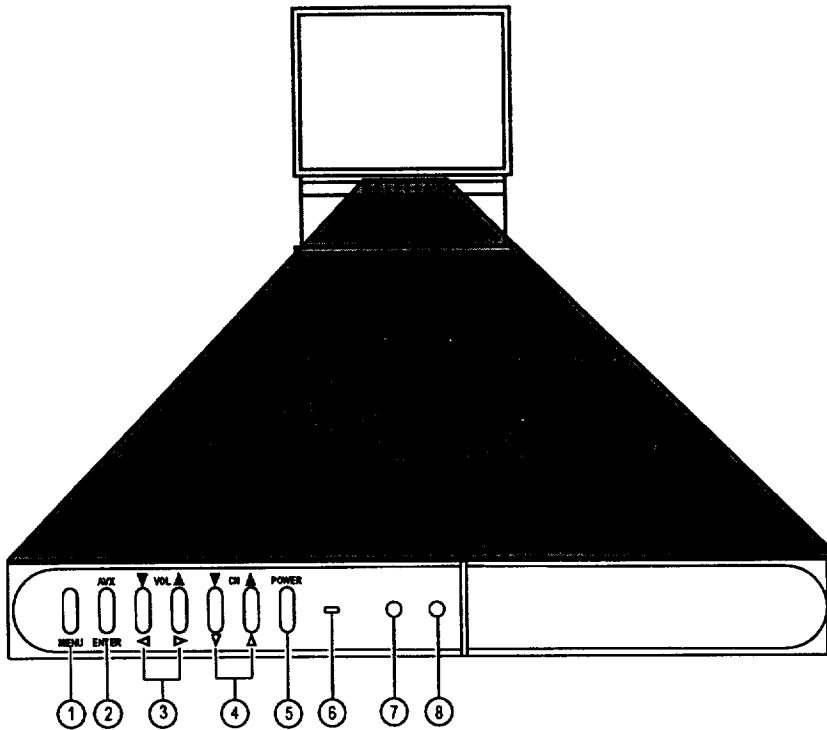

- ① MENU BUTTON**  
This button allows you to enter the MENU mode without using the remote. This makes it possible to set TV features to your preference, without using the remote.
  - ② AVX (Audio/Video) selector/ENTER button**  
Press this button to select the current antenna source, VIDEO: 1 or VIDEO: 2. Your selection is shown in the top right corner of the screen. This button also serves as the ENTER button when in MENU mode.
  - ③ VOLUME level**  
Press these buttons for your desired sound level. The volume level will be displayed on the TV screen. These buttons also serve as the cursor left and right buttons when in MENU mode.
  - ④ CHANNEL selector**  
Press these buttons until the desired channel appears in the top right corner of the TV screen. These buttons also serve as the cursor down and up buttons when in MENU mode.
  - ⑤ POWER button**  
Press this button to turn the TV on or off.
  - ⑥ POWER light**  
You will see a red light when the TV is turned on.
- NOTE:** Your HITACHI TV will appear to be turned "off" if there is no video input when VIDEO: 1 or VIDEO: 2 is selected. Check the Power Light to make sure the TV is off when not in use.
- ⑦ AI (Artificial Intelligence) sensor**  
This "Artificial Intelligence" sensor will make automatic picture adjustments depending on the amount of light in the room to give the best picture. (See page 34.)
  - ⑧ REMOTE CONTROL sensor**  
Point your Remote at this area when selecting channels, adjusting volume, etc.



## REAR PANEL JACKS

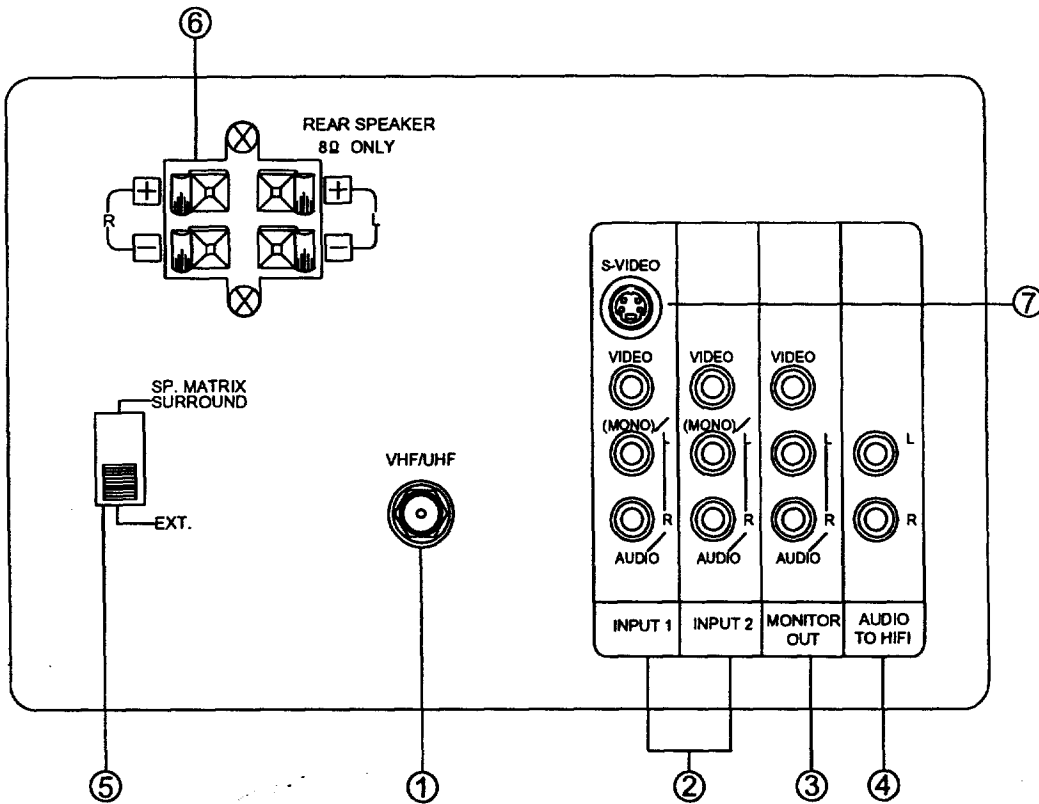

### ① Antenna Input

Use an "F" type coaxial cable to connect an antenna or cable TV (CATV) output to this rear panel jack.

### ② Audio/Video Inputs 1, 2

The "AVX" (Auxiliary video) button will step through each video source and the current antenna input each time it is pressed. Use the audio and video inputs to connect external devices, such as VCR's, camcorders, laser disc players, etc. (If you have mono sound, insert the audio cable into the left channel jack.)

### ③ Monitor Out

These jacks provide fixed audio and video signals which are used for recording.

### ④ Audio to Hi-Fi

These jacks provide variable audio output to a separate stereo system amplifier. With this connection, the audio to the stereo can be controlled by the television's remote control.

### ⑤ Speaker Matrix Surround Switch

Use this switch to choose between the surround and external speaker features. See page 13 for Audio System setup. The TV's Internal Speakers will be switched off when "EXT." is selected.

### ⑥ Rear Speaker Terminals

These terminals are used to connect external speakers, which are used for the surround sound feature. The volume level is controlled by the remote control main volume buttons. Use speakers with 8 Ohm impedance only.

### ⑦ S-Video

Input 1 provides S-Video (Super Video) jacks for connecting equipment with S-Video output capability.

# REAR PANEL CONNECTIONS

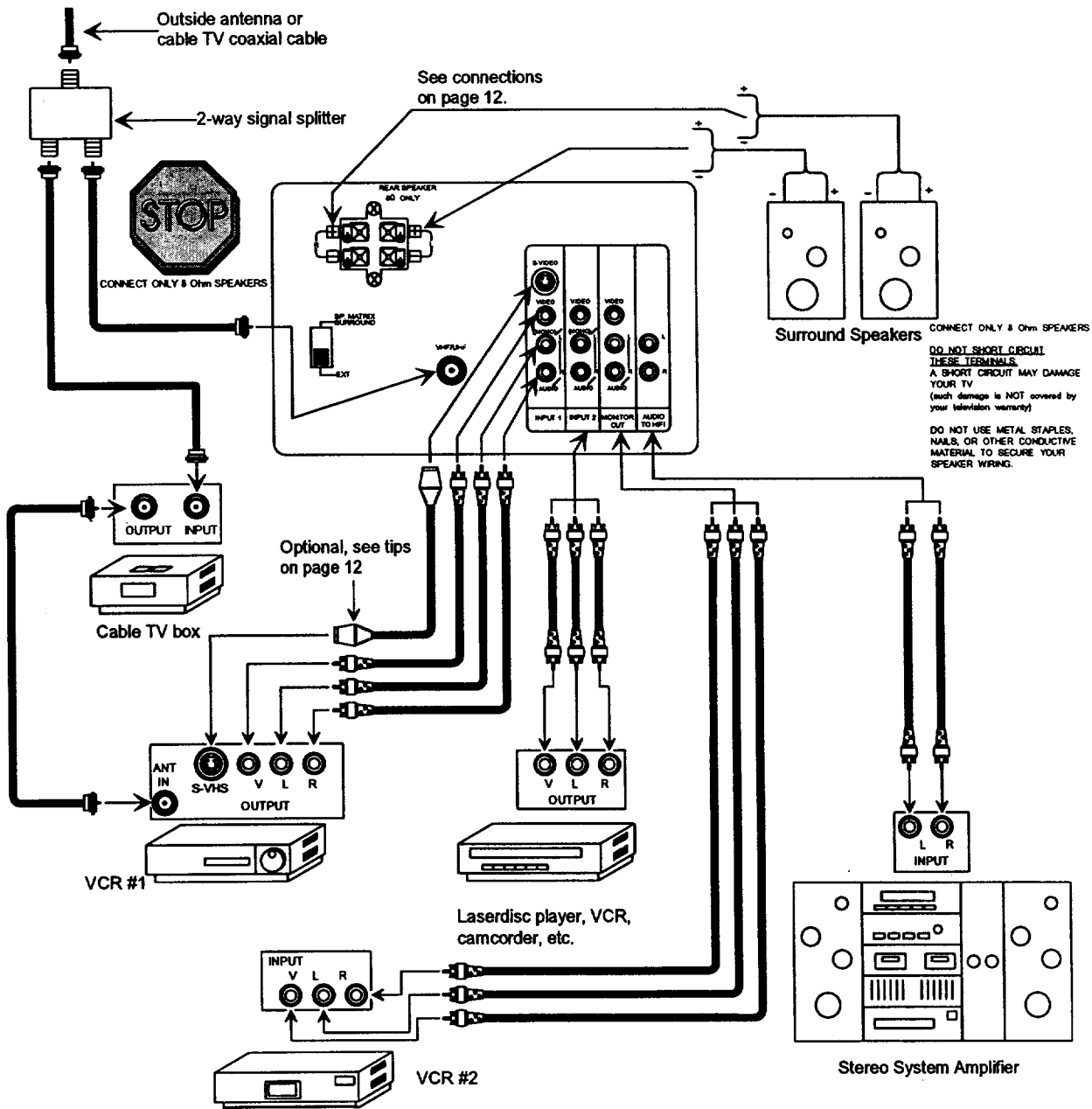

Typical full feature setup. Follow connections that pertain to your personal entertainment system.



## REAR SPEAKER TERMINAL CONNECTIONS

### CONNECT AFTER TURNING THE POWER TO THE TV OFF

Press the Right Speaker red button and insert the positive(+) lead wire into the hole next to the button. Once the wire is in place, pull the red button back to original position and the wire is locked into place. In the same manner, press the Right Speaker black button and insert the negative(-) lead wire. Repeat this procedure for the Left Speaker.



**CAUTION:** Do not short speaker terminals, (do not connect a wire directly across any two terminals). This could cause damage to your audio outputs or damage your TV in other ways.

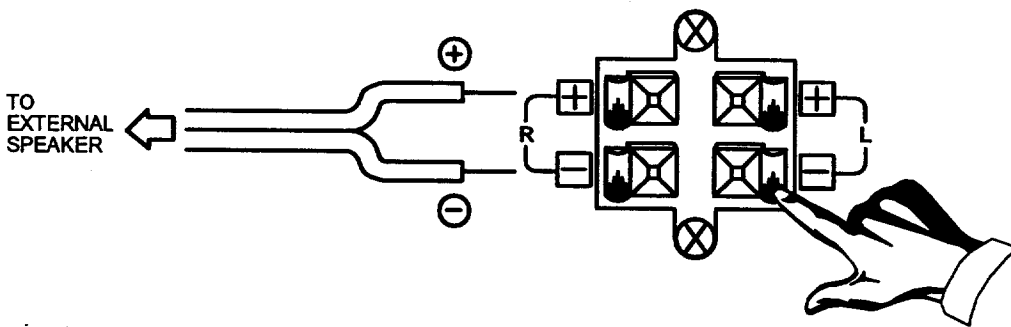

**CAUTION:** Do not connect speakers simultaneously to the REAR SPEAKER terminal of the Projection TV and an external amplifier. This could damage both the TV and the speakers. Your TV was designed to use 8 Ohm speakers only. Any other type may degrade the audio performance of your entertainment system.

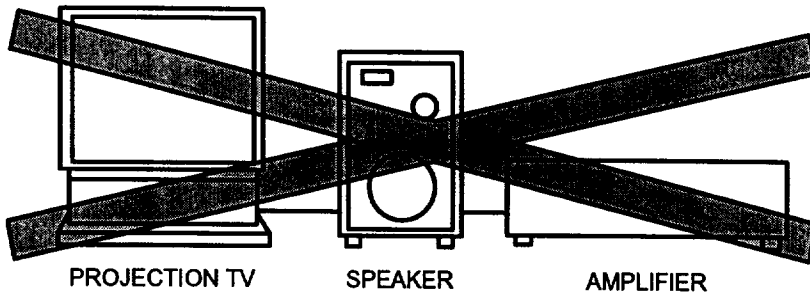

## TIPS ON REAR PANEL CONNECTIONS

The S-Video connection is provided for high performance laser discs, VCR's, etc., that have this feature. Use this connection in place of the standard video connection if your device has this feature.

If your device has only one audio output (mono sound), connect it to the left audio jack on the TV.

Refer to the operating guide of your other electronic equipment for additional information on connecting your hookup cables.

A single VCR can be used for VCR #1 and VCR #2, but note that a VCR cannot record its own video or line output (INPUT: 1 in the example on p. 11). Refer to your VCR operating guide for more information on "line" input-output connections.

# AUDIO SYSTEM SETUP



Match the numbers below to the diagram for speaker placement and refer to the table for the different surround sound requirements.

- ① The television's internal speakers.
- ② These speakers are connected to a separate audio amplifier. Use the "Audio to Hi-Fi" output on the TV.
- ③ These speakers are connected to the Rear Speaker 8 Ohm output on the TV.

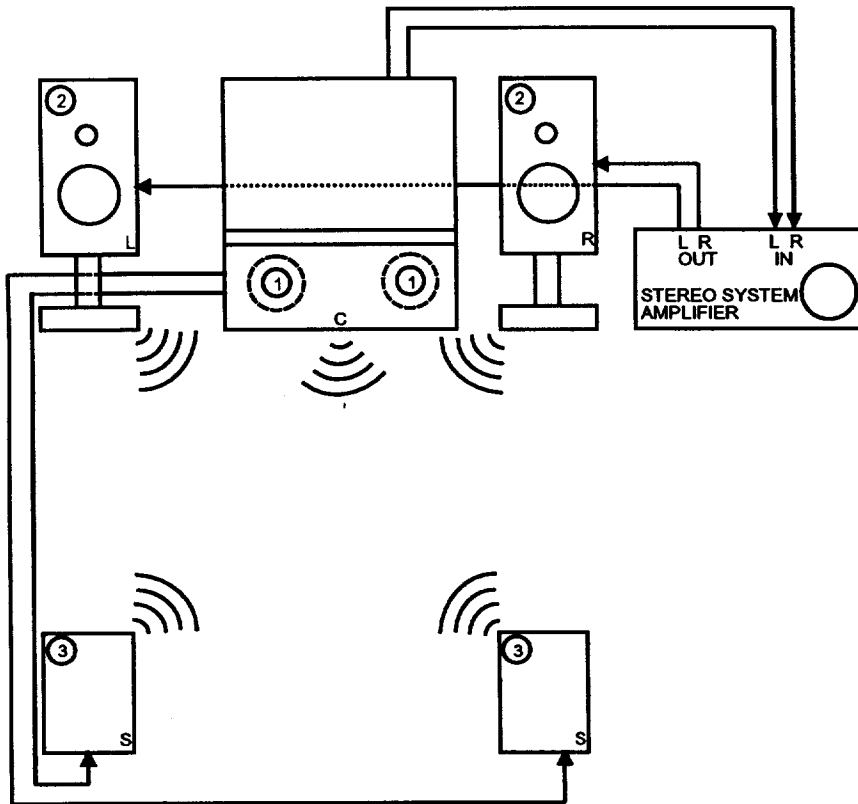

SURROUND FEATURE	SURROUND SWITCH*	REQUIRED CONNECTION	OPTIONAL CONNECTION	EFFECT
OFF	Sp. Matrix Surround	①	②	Receive Mono and Stereo Sound.
MATRIX	Sp. Matrix Surround	① ③	②	"Movie Theater-like" Sound.
EXTERNAL SPEAKERS	Ext.	②	③	This feature turns off the TV's internal speakers.

\*See page 10 for location of Surround Switch.



## THE REMOTE CONTROL (CLU-415UI)

In addition to controlling all the functions on your HITACHI Projection TV, the new remote is designed to operate different types of VCR's and CATV (Cable TV) converters with one touch. Basic operation keys are grouped together in one area.

To operate your TV, point the remote at the remote sensor of the TV and press the TV button on the remote. The remote will now control your TV.

To operate your VCR, point the remote at the remote sensor of the VCR and press the VCR button. The remote will now control your VCR.

To operate your Cable Box, point the remote at the remote sensor of the Cable Box and press the CABLE button on the remote. The remote will now control your cable box.

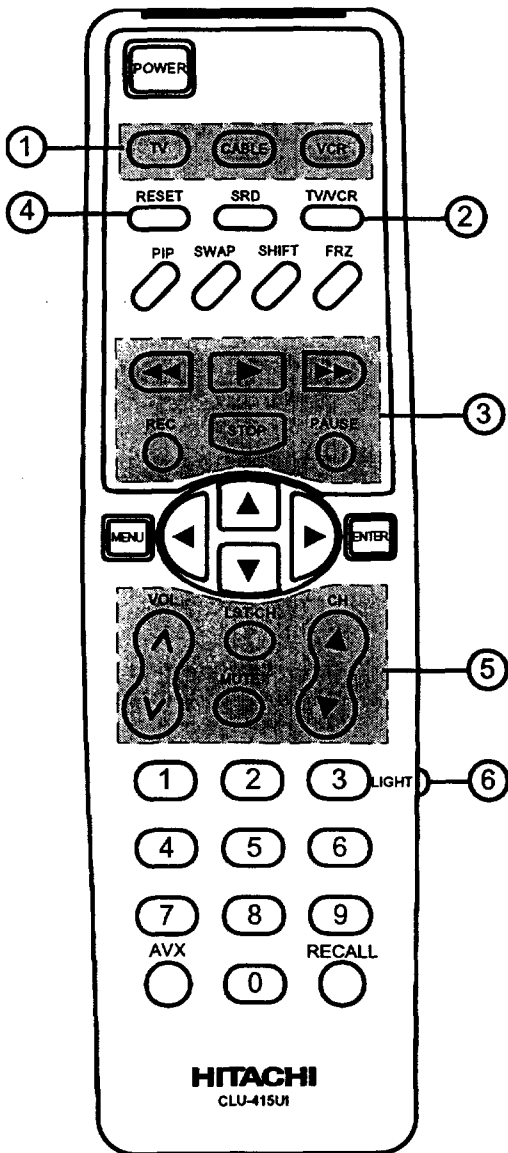

① These buttons allow the remote to control your TV, VCR, or Cable Box depending on which mode is chosen, as explained above.

② **TV/VCR BUTTON**  
When the remote is in the TV or VCR mode, this is the TV/VCR button. When the remote is in the CABLE mode, this is the A/B button.

③ **PRECODED VCR BUTTONS**  
These buttons always transmit the chosen precoded VCR codes.

④ **RESET BUTTON**  
Press RESET to return video and audio to factory settings.

⑤, ⑥ **LIGHT BUTTON**  
When you are in a darkroom, press this button on the side of the remote to light up the buttons shown in ⑤. The light will stay on for about 8 seconds if the light button is not pressed again. These buttons will not appear to light if the room is too bright.

# HOW TO USE THE REMOTE TO CONTROL YOUR TV



## 1 POWER Button

Press this button to turn the TV set on or off. If MESSAGE-1 or MESSAGE-2 is set, it will be displayed when the TV is first turned on. (See page 32.)

## 2 RECALL Button

When you want to check the channel being received, or if it has a stereo (ST) or second audio program (SAP), press the RECALL button.

You can also check the time, and if the ON TIME or OFF TIME has been set. (See page 31.)

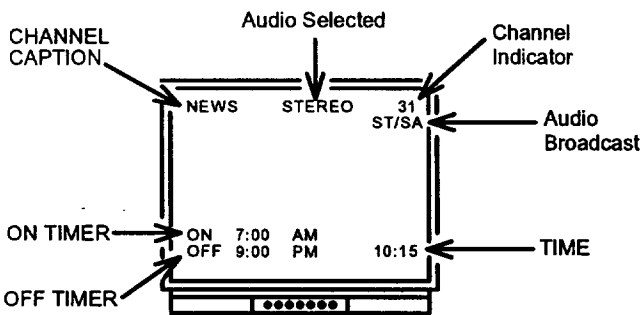

If a video input is used:

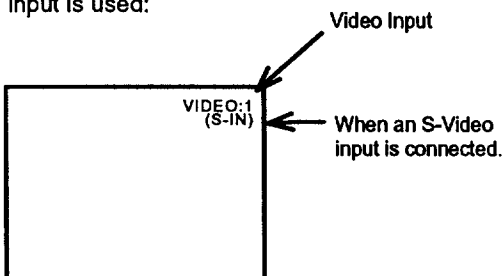

You can also use the RECALL button to quickly clear many of the other On-Screen Displays.

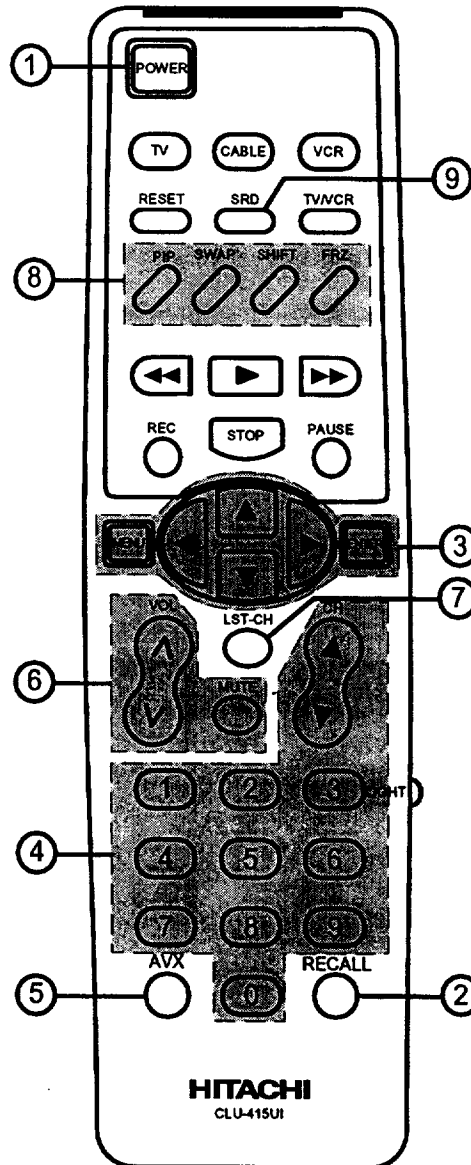



## HOW TO USE THE REMOTE TO CONTROL YOUR TV

### ③ MENU, ENTER, CURSOR Buttons

All the on-screen display features can be set or adjusted by using these buttons.

The "MENU" button will start or exit the on-screen display.

The "CURSOR" buttons will highlight functions or adjust different features.

The "ENTER" button will set features to your preference.

### ④ CHANNEL SELECTOR Buttons

"CHANNEL SELECTOR" buttons are used to set the time, for channel memory, etc.

Enter two or three numbers to select channels. Enter "0" first for channels 1 to 9. For channel 100 and higher, press the "1" button, wait until another dash appears next to the channel display on your TV, then enter the remaining two numbers using the number buttons.

Channel selection may also be performed by pressing channel up (▲) or down (▼).

**NOTE:** The TV may not receive some channels if you are not in the correct AIR/CABLE mode. See page 25.

### ⑤ AVX Button

The AVX (Auxiliary Video) button will select between the antenna signal and the video input jacks each time the button is pressed. If the Picture-in-Picture (PIP) is on, the AVX will select between the video input jacks only. (See page 18.)

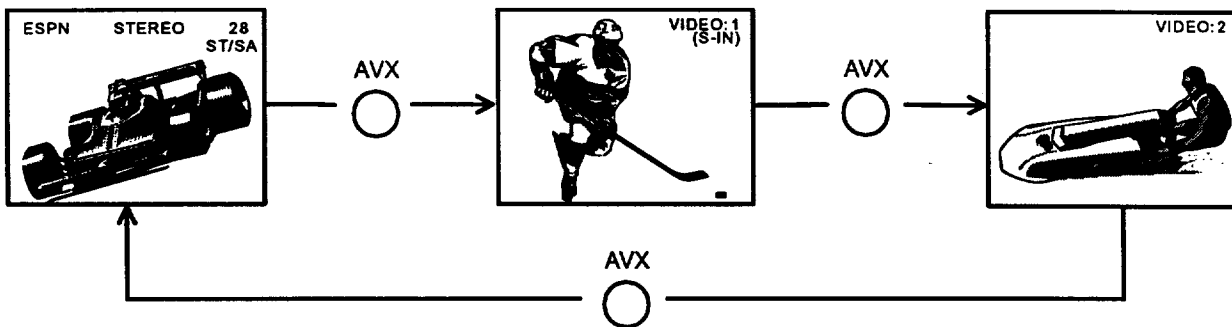





## HOW TO USE THE REMOTE TO CONTROL YOUR TV

### ⑥ VOLUME, MUTE Buttons

Press the "VOLUME" up (▲) or down (▼) button until you obtain the desired sound level.

To turn the sound off instantly to answer the telephone, etc., press the "MUTE" button. Press the "MUTE" button again or press the "VOLUME" up (▲) button to restore the sound.

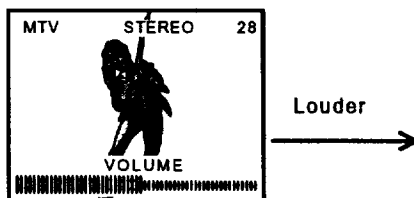

CLOSED CAPTION will be displayed when the "MUTE" button is pressed.

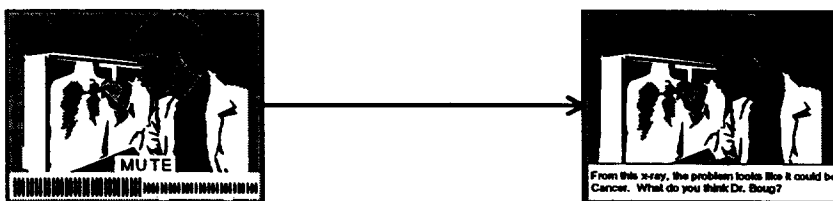

### ⑦ LAST CHANNEL (LST-CH) Button

Use this button to select between the last two channels viewed. (Good for watching two sporting events, etc.)

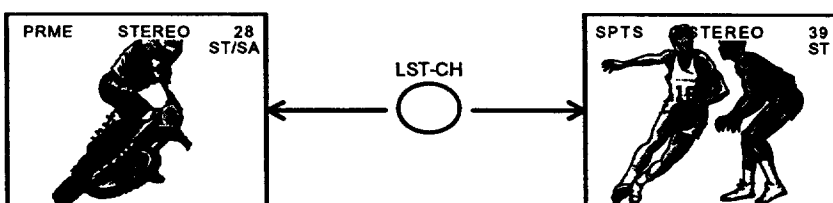

### ⑧ PICTURE-IN-PICTURE

See separate section on page 18 for a description.

### ⑨ (SRD) button

Your Hitachi model does not access surround (SRD) using the remote control. Instead, a switch is provided on the back of your TV to change between Speaker Matrix Surround and External speakers. (See page 13.)



## PICTURE-IN-PICTURE (PIP)

The Picture-in-Picture feature is convenient when you want to watch more than one program at the same time. You can watch a TV program while viewing a VCR program (TV or tape) on the video inputs.

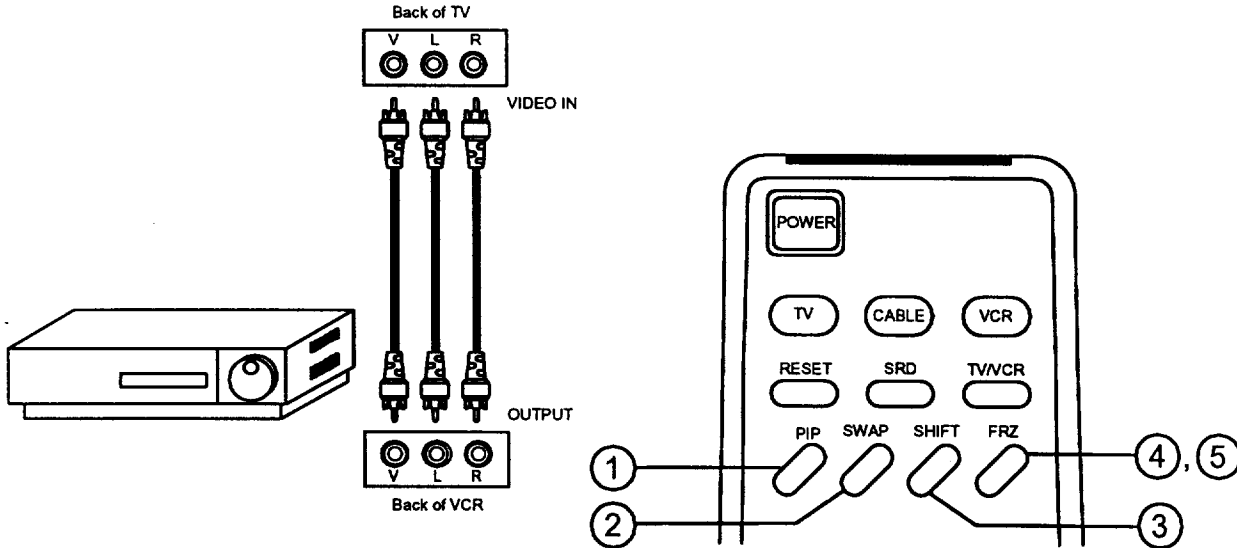

### ① PIP BUTTON

Press the "PIP" button and a sub-picture appears in one corner of the screen. Press the button a second time to remove the sub-picture from the screen. Press the AVX button when the sub-picture is on to change between VIDEO: 1 or VIDEO: 2. The TV channel will always be either the main picture or the sub-picture.

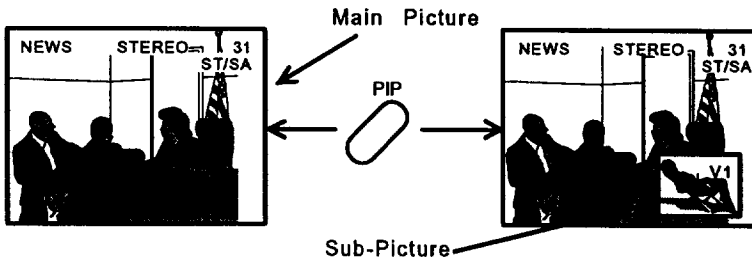

### ② SWAP BUTTON

If you wish to switch what is being shown on the main picture to the sub-picture, press the "SWAP" button.

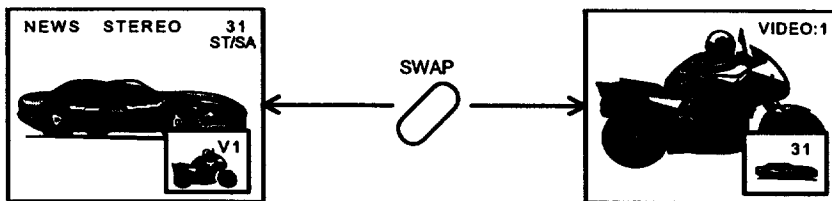

## PICTURE-IN-PICTURE (PIP)



### ③ SHIFT BUTTON

To move the sub-picture to another corner, press the "SHIFT" button. The sub-picture moves one step counterclockwise every time the "SHIFT" button is pressed.

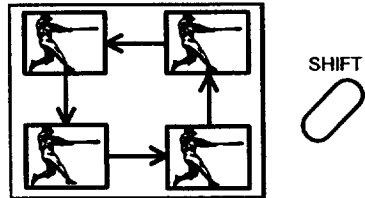

### ④ FREEZE (FRZ) BUTTON

If you wish to freeze the sub-picture, press the "FRZ" button. This is convenient when trying to write down the address for a mail order company, recording statistics for a sporting event, etc. To return to motion, press the button again.

### ⑤ FREEZE (FRZ) BUTTON WITHOUT A SUB-PICTURE (QUICK FREEZE)

Press this button without a sub-picture to freeze the picture you are currently viewing. Press this button again to return to normal viewing. The SWAP button will not work with this QUICK FREEZE function.

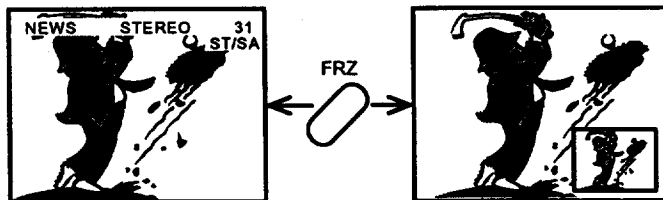

**CAUTION:** A pattern burn may develop if the sub-picture is left in the same corner permanently. If the PIP feature is used frequently, occasionally shift the sub-picture to a different corner.

**NOTE:** Only sound from the main picture can be heard.



## USING THE REMOTE TO CONTROL VCR FUNCTIONS

### Operating the precoded function for your VCR

This remote is designed to operate different types of VCRs. You must first program the remote to match the remote system in your VCR. (Refer to page 22.)

1. Turn ON your VCR.
2. Aim the remote control at the front of your VCR.
3. While holding down the VCR button on the remote, enter the 2 digit preset code that matches your VCR as shown on page 22. The remote will turn off your VCR when the correct 2 digit preset code is entered. When this occurs, the remote control is programmed for your VCR. If the VCR does not turn off after 5 seconds, try a different 2 digit preset code.
4. The remote will now control your VCR.

#### NOTES:

1. If your VCR cannot be operated after performing the above procedures, this means that your VCR's codes have not been precoded into the remote.
2. In the unlikely event that your VCR cannot be operated after performing the above procedures, consult your VCR operating guide.
3. The remote control will remember the codes you have programmed in until the batteries are removed from the remote control. After replacing the batteries repeat the entire programming procedure stated above.
4. If your VCR does not have a power function, the remote will issue the CHANNEL ▲ function.

#### ① VCR BUTTON

This allows the remote to control your VCR by setting it to VCR mode.

#### ② PRECODED VCR BUTTONS

These buttons transmit the chosen precoded VCR codes.

#### ③ EXCLUSIVE TV BUTTONS

These buttons are for operating the TV.

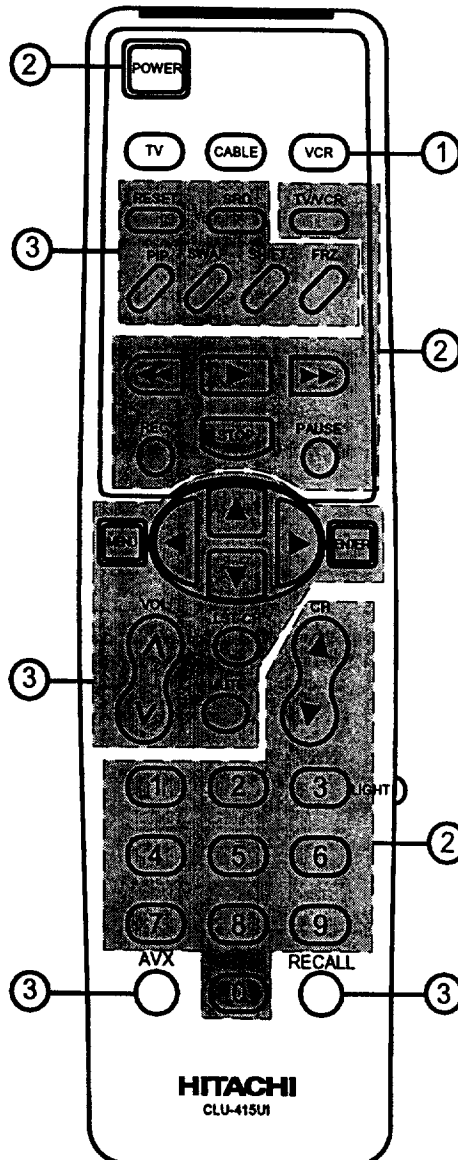

# USING THE REMOTE TO CONTROL CABLE BOX FUNCTIONS



## Operating the precoded function for your cable box

This remote is designed to operate different types of Cable Boxes. You must first program the remote to match the remote system in your cable box. (Refer to page 22.)

1. Turn ON your cable box.
2. Aim the remote control at the front of your cable box.
3. While holding down the CABLE button on the remote, enter the 2 digit preset code that matches your cable box as shown on page 22. The remote will turn off your cable box when the correct 2 digit preset code is entered. When this occurs, the remote control is programmed for your cable box. If the cable box does not turn off after 5 seconds, try a different 2 digit preset code.
4. The remote will now control your cable box.

### NOTES:

1. If your cable box cannot be operated after performing the above procedures, this means that your cable box codes have not been precoded into the remote.
2. In the unlikely event that your cable box cannot be operated after performing the above procedures, consult your cable box operating guide.
3. The remote control will remember the codes you have programmed in until the batteries are removed from the remote control. After replacing the batteries repeat the entire programming procedure stated above.
4. If your cable box does not have a power function, the remote will issue the CHANNEL ▲ function.

- ① CABLE BUTTON**  
This button allows the remote to control your cable box by setting it to CABLE mode.
- ② TV/VCR BUTTON**  
When the remote is in CABLE mode, this is the A/B button.
- ③ ENTER BUTTON**  
If your cable box does not have an enter function, this button will send the TV enter code.
- ④ RECALL BUTTON**  
If your cable box does not have a last channel function, this button will send the TV channel recall code.
- ⑤ PRECODED CABLE BOX BUTTONS**  
These buttons transmit the chosen precoded CATV codes.
- ⑥ EXCLUSIVE TV BUTTONS**  
These buttons are for operating the TV.

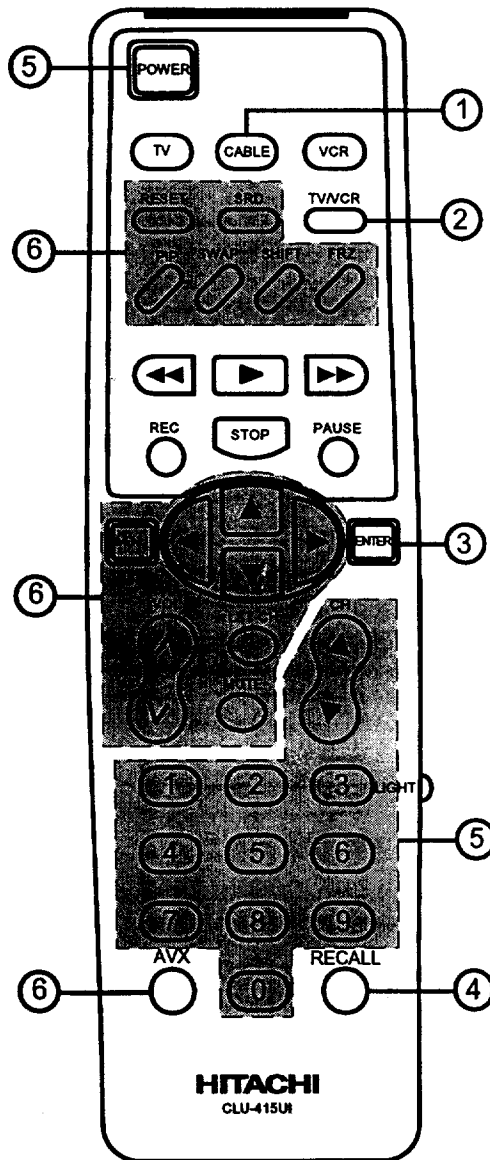



## VCR AND CABLE BOX CODES

VCR BRAND	CODE	VCR BRAND	CODE	CABLE BRAND	CODE
Adventura	00	Motorola	09,20	ABC	01,03,05,09,11,12,14,30
Aiko	50	MTC	00,48	Antronix	44
Aiwa	00	Multitech	00,27	Archer	28,40,44
Akai	14,23,49	NEC	11,13,14,26	Belcor	31
American High	09	Nikko	10	Cable Star	31
Asha	48	Noblex	48	Century	40
Audiovox	10	Olympus	09	Citizen	40
Beaumarck	48	Olymus	47	Colour Voice	19,25
Bell & Howell	30	Optimus	20	Comtronics	29,34
Brandt	38	Panasonic	09,35,46,47	Contec	15
Broksonic	33,37,43	Penney	09,10,11,13,15,21,48	Eastern	02
Canon	09	Pentax	15,24,31	Electricord	37
Capelhart	05	Philco	09	Garrard	40
Carver	28	Philips	09,28,32	GC Electronics	31,44
CCE	27,50	Pilot	10	Gemini	13,32,36,46
Citizen	50	Pioneer	26	General Instrument	09
Colt	27	Portland	05	Hamlin	08,16,27,49,50
Craig	19,27,48	Protec	27	Hitachi	09
Curtis Mathes	09	Pulsar	12	Hytex	05
Cybernex	48	Quartz	18	Jasco	40
Daewoo	03,05,17,29,50	Quasar	09	Jerrold	03,09,10,12,13,20,30
Daytron	05	Radio Shack	00,10	Macom	26
Dynatech	00	RCA	15,22,24,31,34,39	Magnavox	21
Emerex	06	Realistic	00,09,10,18, 19,20,30,48	Memorex	00
Emerson	00,01,10,16,23, 33,37,40,41,43,44	Ricoh	08	Movie Time	35,37,42
Fisher	19,21,25,30	Runco	12	NSC	35,36,42
Fuji	07,09	Samsung	17,48	Oak	05,15,47
Funai	00	Sanky	12,20	Panasonic	17,38
Garrard	00	Sansui	14,26	Paragon	00
GE	09,22,24	Sanyo	18,19,30,48	Philips	19,21,22,23,24,25,40,46,54
Goldstar	04,10,11	Scott	16,17,33,37, 42,43,44	Pioneer	18,39
Gradiente	00	Sears	09,10,15,18, 19,21,25,30,31	Pulsar	00
Harley Davidson	00	Sharp	20	RCA	17
Harman/ Kardon	11	Shintom	27	Realistic	44
Harwood	27	Shogun	48	Regal	16,49,50,53
HI-Q	19	Singer	27	Regency	02
Hitachi	00,15,24,31	Sony	06,07,08,09	Rembrandt	09,36
Jensen	14	STS	15	Runco	00
JVC	02,14,26	Sylvania	00,09,16,28,32	Samsung	29,39
Kenwood	11,14,18,26	Symphonic	00	Scientific Atlanta	04,06,14,52
KLH	27	Tatung	14	Signal	13,29
Kodak	09	Teac	00,14	Signature	09
Lloyd	00	Technics	09,35	SL Marx	29
Logik	27	Teknika	00,09,10	Sprucer	17,55
LXI	10	Telefunken	38	Standard Components	41
Magnavox	09,12,28,32,34	TMK	40,48	Starcom	03,13,30
Magnin	48	Toshiba	16,17,25,42,44	Stargate	13,29
Marantz	09,11,28	Totevision	10,48	Starquest	13
Marta	10	Unitech	48	Sylvania	01
Matsushita	09	Vector	17	Televue	29
MEI	09	Vector Research	11,13	Texscan	01
Memorex	00, 09,10,12,18, 19,20,30,48	Video Concepts	13,17,23	Tocom	10,11,33
MGA	16,23	Videosonic	48	Toshiba	00
MGN Technology	48	Wards	00,09,15,19, 20,27,34,44,48	Tusa	13
Minolta	15,31	XR-1000	27	TV86	35
Mitsubishi	16,23,26,36,45,49	XR1000	00,09	Unika	40,44
		Yamaha	11,14	United Artists	05
		Zenith	07,08,12	United Cable	03
				Universal	28,31,37,40,43,44
				Videoway	48
				Viewstar	21,34,35,45
				Zenith	00

# EASY GRAPHIC GUIDE



1. Press MENU on the remote control to display the different features on your HITACHI TV. The feature to be selected will be highlighted in yellow, the buttons used to choose your selection will be highlighted in blue, and the selection you have chosen will be highlighted in red.
2. Press the CURSOR buttons to highlight a different feature.
3. Press ENTER on the remote control to select a feature.

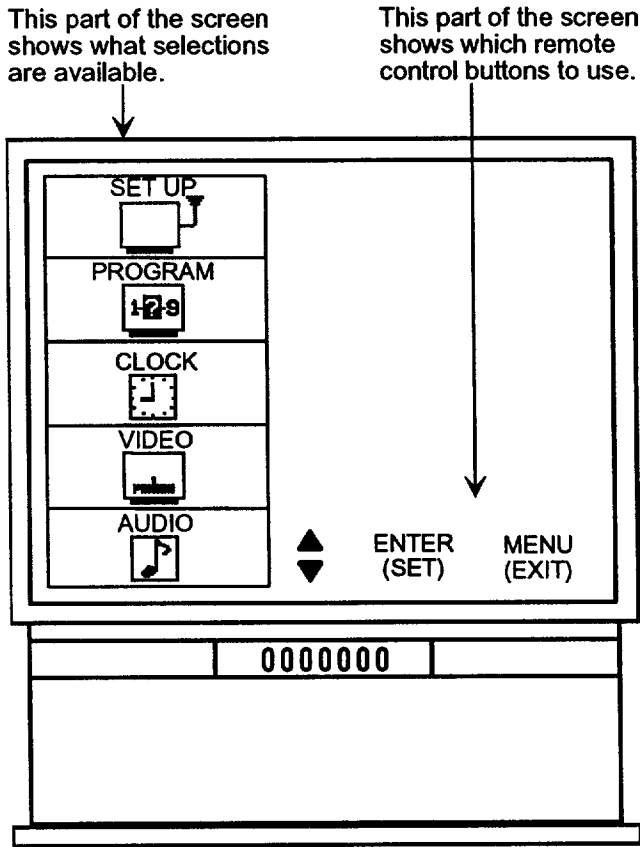
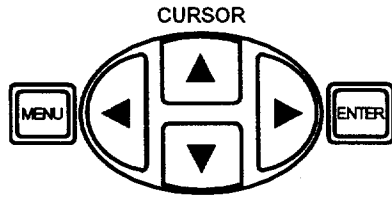



## EASY GRAPHIC GUIDE

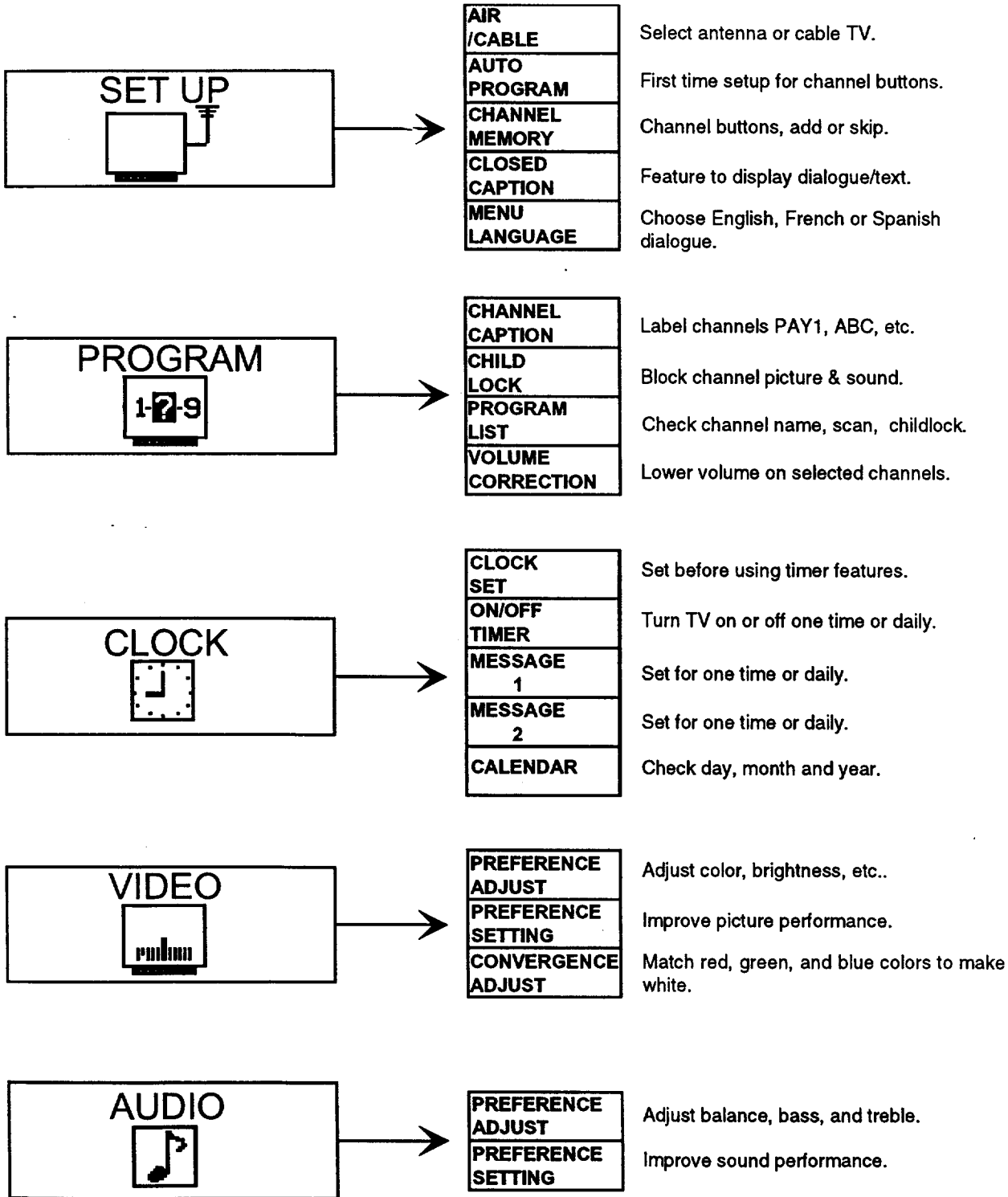



# SET UP



Select SET UP when setting your TV up for the first time. Use the CURSOR ▲, ▼ buttons on the remote to highlight the function desired.

Your selection is shown here →

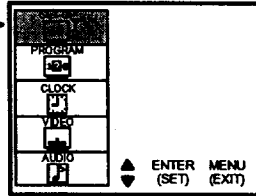

**NOTE:** To see an auto-demonstration of the on-screen display, press and hold the POWER button on the TV set for approximately 5 seconds. Press the POWER button on the TV again to end the auto-demonstration.

## AIR /CABLE

Select AIR if you are using an indoor or outdoor antenna. Select CATV if you have cable TV.

Press the CURSOR buttons to highlight the correct AIR/CABLE mode and press MENU to exit. Your choice will be shown on the display.

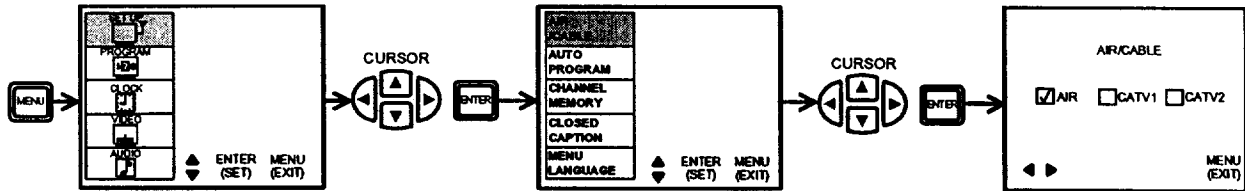

RECEPTION BAND		
AIR	CATV 1 or CATV 2	
	CATV CHANNEL	Indicated on the screen
VHF 2 ~ 13ch UHF 14 ~ 69ch	VHF 2 ~ 13	2 ~ 13
	Mid band A ~ I A-5 ~ A-1	14 ~ 22 95 ~ 99
	Super band J ~ W	23 ~ 36
	Hyper band W + 1 ~ W + 28	37 ~ 64
	Ultra band W + 29 ~ W + 84	65 ~ 125

Reception channels for each mode are shown at the left.

Refer to your cable or TV guide for channel identification standards.

If certain CATV channels are poor or not possible in the CATV1 mode, set AIR/CABLE to CATV2.

## SET UP

### AUTO PROGRAM

This feature will automatically store active TV channels in CHANNEL MEMORY. This will allow you to skip over unused channels when using the CHANNEL UP (▲) or DOWN (▼) buttons.

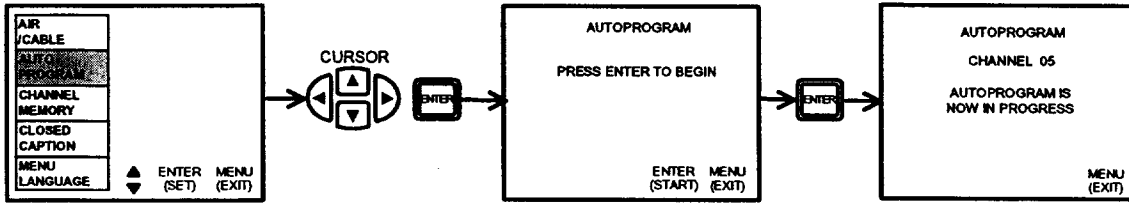

If the MENU button is pressed while the auto programming function is engaged, programming will stop. See CHANNEL MEMORY to add or erase additional channels.

### CHANNEL MEMORY

Use this function after AUTOPROGRAM to add or erase additional channels to the remote control CHANNEL ▲, ▼ buttons. Your choice will be highlighted in yellow.

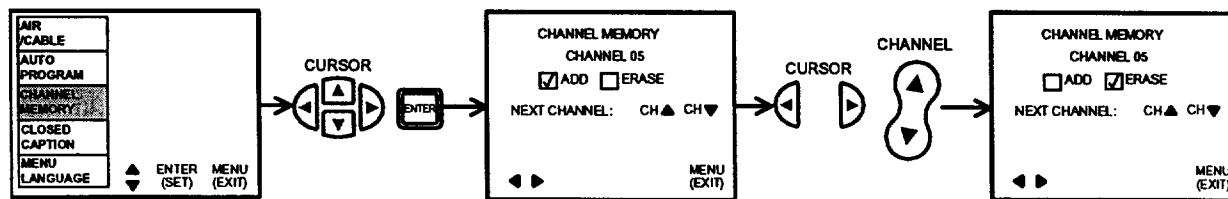

Add or erase additional channels while still in CHANNEL MEMORY using the CHANNEL ▲, ▼ buttons or number buttons and then add or erase using the CURSOR ◀, ▶ buttons.

## SET UP



### CLOSED CAPTION

Closed captions are the dialogue, narration, and/or sound effects of a television program or home video which are displayed on the TV screen. Your local TV program guide denotes these programs as **CC** or .

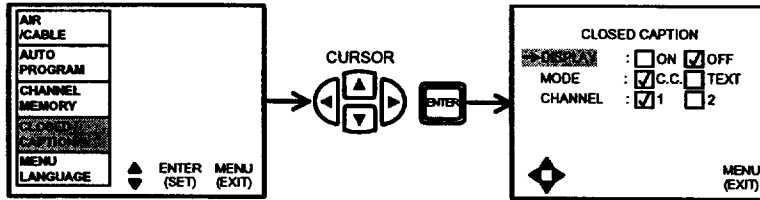

The selected function will be in yellow. Your choice for the function will be in red.

**DISPLAY: ON/OFF** is to turn the **CC** display on or off.

**MODE: C.C.** (Closed Caption) is for the program you are viewing.

**MODE: TEXT** is for additional information such as news reports or a TV program guide. This information covers the entire screen and viewing the TV program is not possible. TEXT may not be available with every **CC** program.

**CHANNEL: 1** is used for the primary language (usually English).

**CHANNEL: 2** is sometimes used for a second language (may vary by region).

Use the CURSOR  or  to highlight the function to change, press ENTER to change the function, and press MENU to exit.



MODE: CC

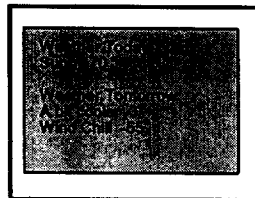

MODE: TEXT

**NOTE:** The word MUTE will not be displayed if the DISPLAY is ON. If you do not have sound, make sure MUTE is not set. CCD will display when "MUTE" is pressed, whether CCD is in the "ON" or "OFF" mode. (Certain models only.)

### MENU LANGUAGE

This feature will allow you to select any one of 3 different languages for all on screen displays.

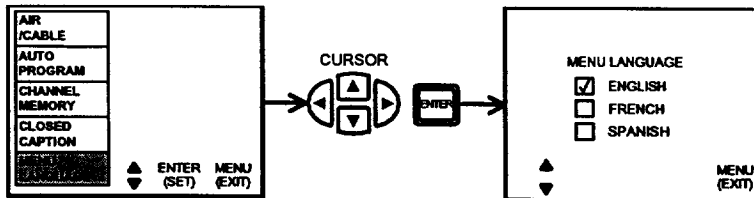

Use the CURSOR ,  buttons to select the MENU LANGUAGE of your choice.

Press MENU to exit.

# PROGRAM

## PROGRAM

This selection contains advanced features which will make TV viewing easier and more enjoyable.

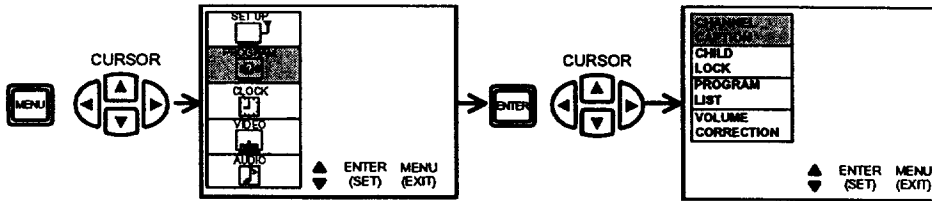

## CHANNEL CAPTION

Use this feature to give up to 30 channels a name.

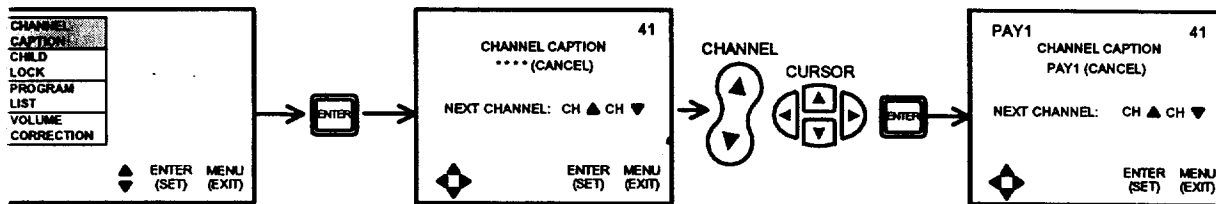

- Press the CURSOR ▲, ▼ to select letters.
- Press the CURSOR ◀, ▶ to change position.
- Press ENTER to set the CHANNEL CAPTION and it will appear in the top left corner of the screen.
- Press CHANNEL ▲, ▼ or the number buttons to select and label additional channels.
- Press MENU to exit.

- The (\*) represents a blank space.
- Select CANCEL to erase a CHANNEL CAPTION.
- To view the CHANNEL CAPTION, press the RECALL button on your remote control.

## CHILD LOCK

This function will block out the picture and sound of the selected channel.

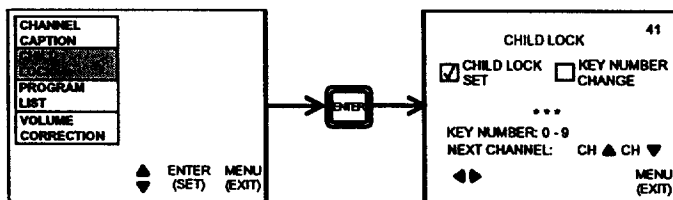



# PROGRAM

The code to set or cancel CHILD LOCK is a three digit key number. The factory preset key number is 000.

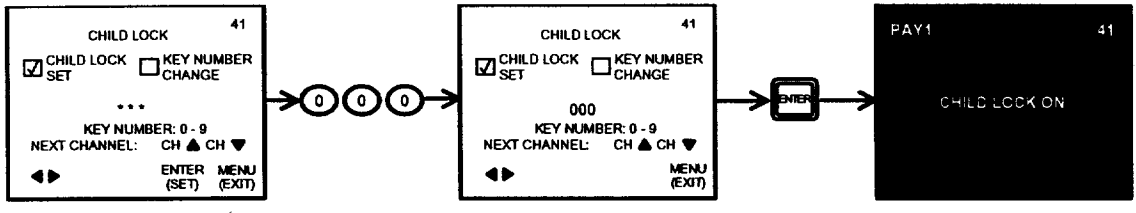

The picture and sound will now be blocked out for this channel. Repeat the same steps to cancel the CHILD LOCK.

To change the key number, select key number change. Enter the old number (factory preset 000 for first time use), then enter a new three digit key number you prefer.

If you forget your key number, use the factory code 777 to erase your key number. This will reset the key number back to the factory preset 000.

## PROGRAM LIST

This function allows you to view which channels are labeled in CHANNEL CAPTION (NAME), which have been added to CHANNEL MEMORY (SCAN), and which are protected by CHILD LOCK (LOCK).

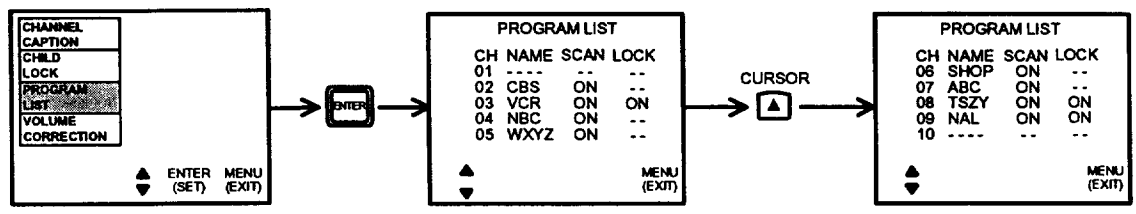

Press CURSOR ▲, ▼ to review more channels.  
Press MENU to exit.

**VOLUME CORRECTION**

Use this function to reduce the volume level of up to four TV channels that sound loud compared to other TV channels.

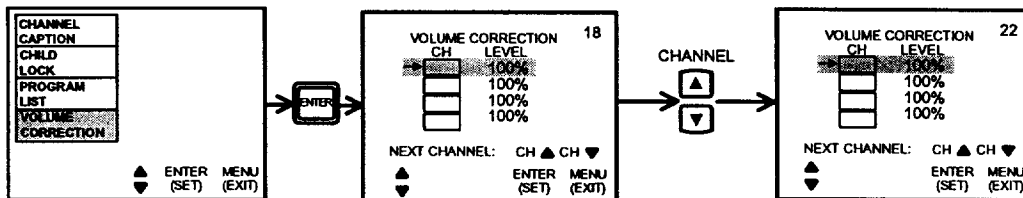

Press the CURSOR ▲, ▼ to select one of the four volume corrections.  
Use the CHANNEL ▲, ▼ or number buttons to select a channel.

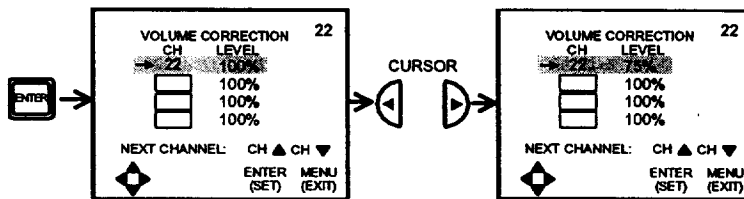

Press ENTER to set the channel.  
Press the CURSOR ◀, ▶ to adjust volume level.  
Press MENU to exit.

- NOTE:**
1. VOLUME CORRECTION adjustment is for the channel displayed in the top right corner of the screen. To adjust a different channel, you must select the channel with the channel or number buttons and press ENTER.
  2. If the channel has been corrected before, use the CURSOR ▲, ▼ to highlight that channel then use the CURSOR ◀, ▶ to change the level.
  3. To erase a channel from the volume correction, select channel 00 and press ENTER.
  4. The volume level will change from 50% to 100% in 5% steps.



# CLOCK



Use this feature for all time related functions.

## CLOCK SET

The time must be set before you can use the on/off timer or automatic message.

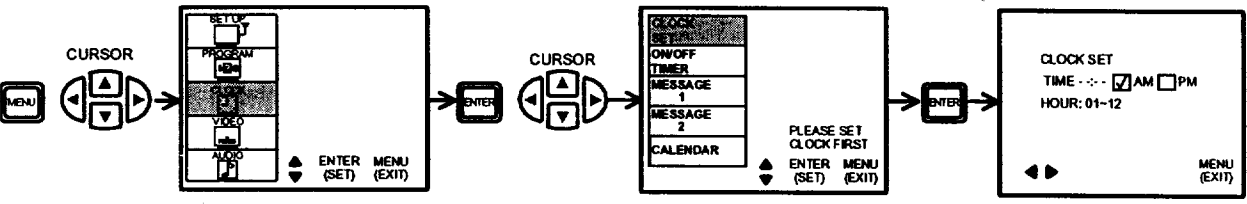

Use the NUMBER buttons and CURSOR ◀, ▶ to set the time. The AM or PM selected will be highlighted in red.

## ON/OFF TIMER

This function will automatically turn the TV on or off, one time only or everyday.

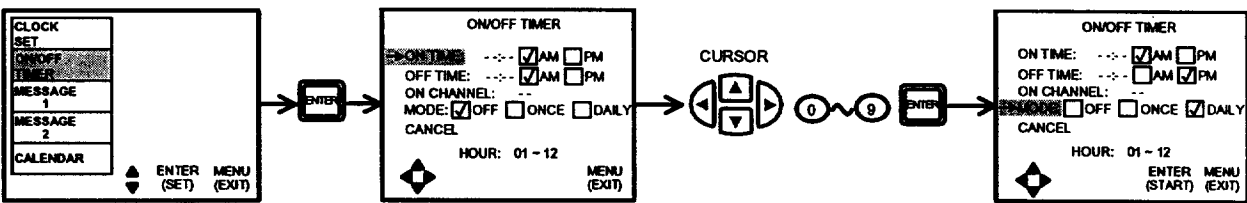

The selection to change will be in yellow. Press the number buttons to select the time the TV will turn on or off. (AM: 1, PM: 2) Press the CURSOR ◀, ▶ buttons for MODE: ONCE (one time only) or MODE: DAILY (TV will turn on/off at the same time every day). Press CHANNEL ▲, ▼ or the NUMBER buttons to set the channel the TV will tune to when it automatically turns on.

Your choice for AM/PM and MODE will appear in red. Press ENTER to start. Select CANCEL and press ENTER to erase times.

**NOTE:** You can set either ON TIME only, OFF TIME only, or both. The mode will be the same for both. If no remote control button is pressed after ON timer is activated, the TV will automatically turn off after 3 hours.

**CAUTION:** Do not use your TV as a deterrent when away from home by using both the ON and OFF TIMERS. For safety, the TV should be turned off when you are away from home.



# CLOCK

## MESSAGE-1

Use this function to set one or two personal messages once a day or one time only.

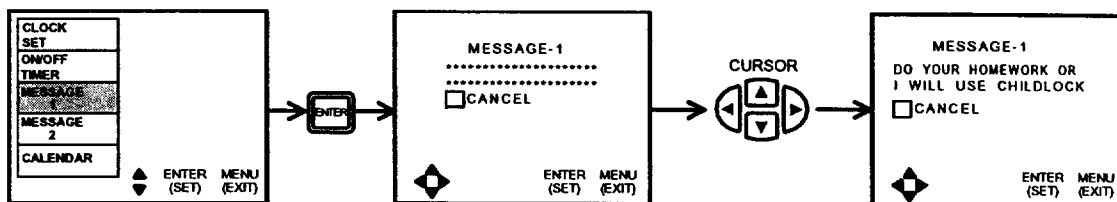

Use the CURSOR ▲, ▼ to select a letter or other character.

Use the CURSOR ◀, ▶ to change position.

Press ENTER when message is finished.

The asterisk (\*) represents a blank space.

Move the CURSOR ◀, ▶ until (CANCEL) is red and press ENTER to erase message.

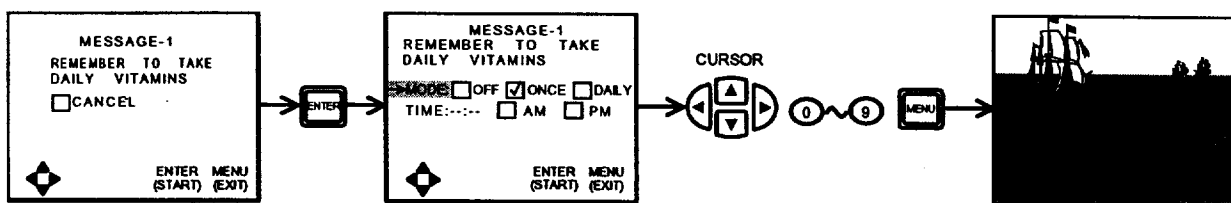

Use CURSOR ▲, ▼ to choose MODE or TIME.

Use CURSOR ◀, ▶ to set MODE when it is yellow. Your choice will be in red.

Use the NUMBER buttons to set the time.

Press ENTER to start and MENU to exit.

**Note:** At the selected time, the message will be displayed until a remote control button is pressed.  
 Message-2 works in the same way as Message-1.  
 Each message is capable of storing up to 40 characters.

## CALENDAR

Use this function to check the day, month, and year.

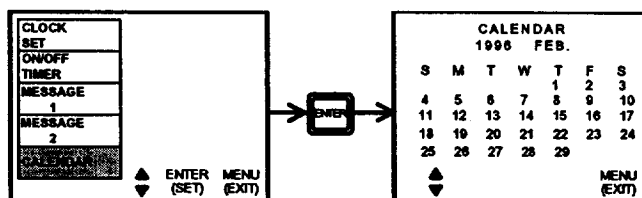

Use the CURSOR ▲, ▼ buttons to change the month.

Press MENU to exit.





# VIDEO

## VIDEO

Select VIDEO to adjust picture settings, improve picture quality, and to adjust convergence.

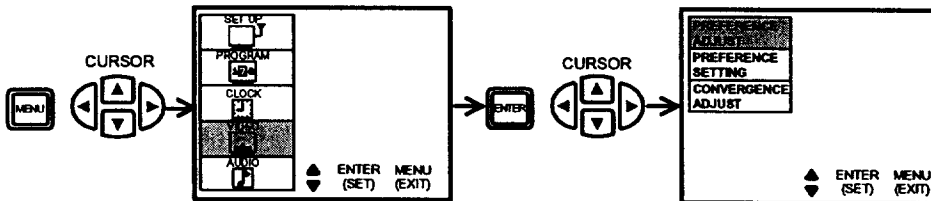

## PREFERENCE ADJUST

Use this feature to adjust contrast, color, tint, brightness, and sharpness.

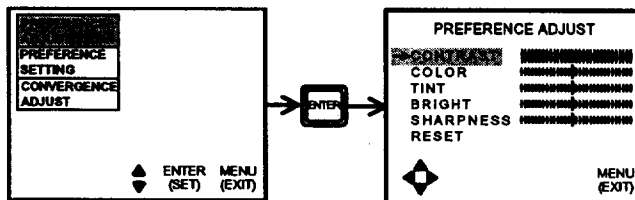

Press the CURSOR buttons to select and make adjustments.  
The function to be adjusted will be in yellow.

- CONTRAST:** Use this function to change the contrast between black and white level in the picture. This adjustment will only affect the picture when the PICTURE SETTING AI is OFF. (See page 34)
- COLOR:** Use this function to adjust the level of color in the picture.
- TINT:** Use this function to adjust flesh tones so they appear natural.
- BRIGHT:** Use this function to adjust overall picture brightness.
- SHARPNESS:** Use this function to adjust the amount of fine detail in the picture.
- RESET:** When RESET is selected, press ENTER to return video adjustments to factory preset conditions.



## VIDEO

### PREFERENCE SETTING

Your HITACHI TV has an AI (Artificial Intelligence) function which will automatically adjust picture settings to produce the highest quality picture possible.

When AI is yellow, use the CURSOR ◀, ▶ to turn the AI on or off. Your choice will be in red.

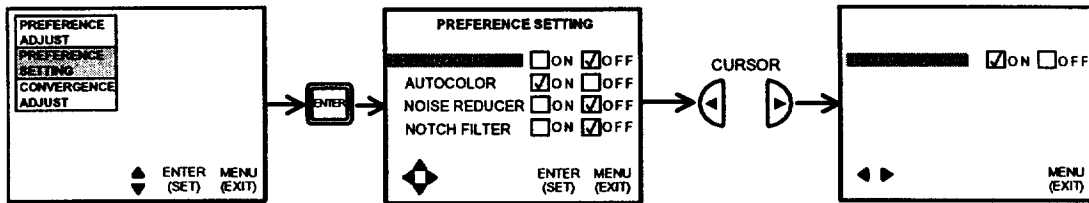

Use the CURSOR ▲, ▼ to select function.

Use the CURSOR ◀, ▶ to turn function on or off. Your choice will be in red.

### AI (ARTIFICIAL INTELLIGENCE)

When the AI function is on, the TV's internal computer will perform the following:

1. Automatically monitor and adjust contrast depending on room lighting (sensor is located in the front panel), to produce a more natural picture.
2. Automatically monitor and adjust color levels and maintain natural flesh tones.
3. Automatically compensate for weak or strong TV signals to produce a clear picture.

Turn the AI function off to control other PREFERENCE SETTINGS.

### AUTOCOLOR

The AUTOCOLOR function automatically monitors and adjusts the color to maintain constant color levels even after a program or channel changes. It also maintains natural flesh tones while preserving fidelity of background colors. For best picture performance leave the AUTOCOLOR function on.

### NOISE REDUCER

The NOISE REDUCER automatically reduces conspicuous noise in the picture without degrading picture quality.

### NOTCH FILTER

Turn on the Notch Filter when viewing a television program from one of the regular video inputs to improve the picture appearance, especially around the outline of buildings, signs, letters, etc.

Turn off the Notch Filter when viewing a program from the S-Video input to get the maximum sharpness and clarity out of the picture.



**CONVERGENCE ADJUST**

Your Projection TV has three color projection tubes: one for red, one for green, one for blue. When mixed together in the proper proportion, the output of these three color tubes can produce any color. To produce these colors, however, the beams must be precisely aligned over each other so that the colors can be mixed. The process of aligning these picture beams is called "convergence".

To simplify convergence, the following feature allows you to display a test pattern of horizontal and vertical lines on the screen. Properly converged, the lines appear white, which is actually a combination of the outputs of the three color tubes. The output of the green tube is stationary. The outputs of the red and blue tubes can be adjusted. When properly aligned, the outputs of all three tubes should be directly over each other to produce the white lines.

Over a period of time, the picture tubes can drift out of alignment due to normal bumps and vibrations or moving the TV. If you move your TV, or if, after a time, you notice color rings or halos around objects in the picture, you may want to converge (align) the colors.

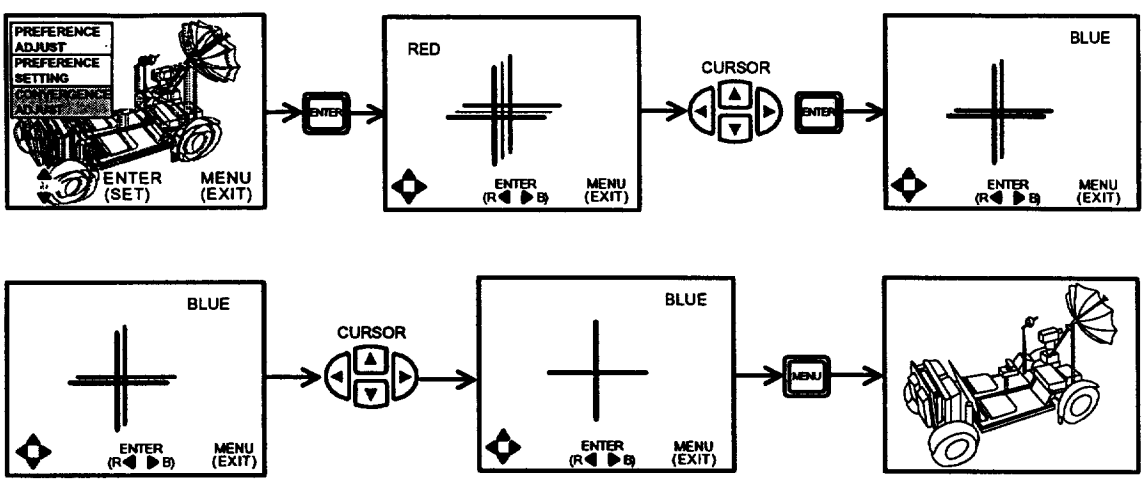

- Press the CURSOR ▲, ▼ to move the color displayed up or down.
- Press the CURSOR ◀, ▶ to move the color displayed left or right.
- Press ENTER to change the color.
- Press MENU to exit.



## AUDIO

### AUDIO



Select AUDIO to adjust the TV to your preference, to improve the sound quality, and to select special sound effects.

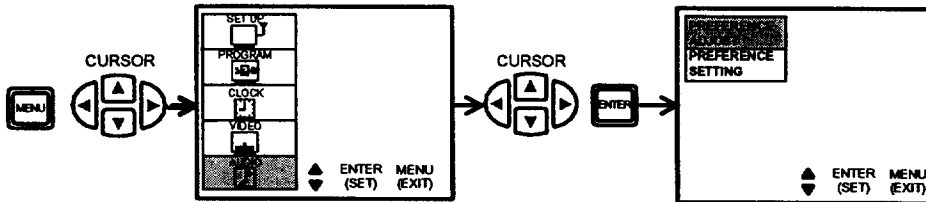

### PREFERENCE ADJUSTMENT

Use this to set balance, bass, and treble.

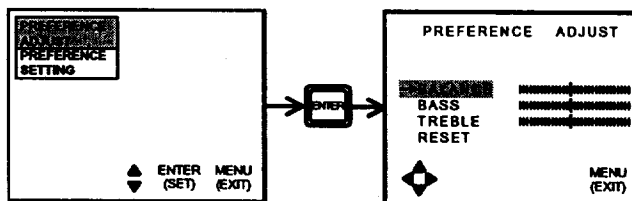

Press the CURSOR buttons to select and make adjustments. The function to be adjusted will be in yellow.

**BALANCE:** This function will control the left to right balance of the TV internal speakers, the AUDIO TO HI-FI output, and the surround speakers.

**BASS:** This function controls the low frequency audio to all speakers.

**TREBLE:** This function controls the high frequency audio to all speakers.

**RESET:** When RESET is selected, press ENTER to return audio adjustments to factory preset conditions.



# AUDIO

## PREFERENCE SETTING

Use PREFERENCE SETTING to improve the sound performance of your TV depending on listening conditions.

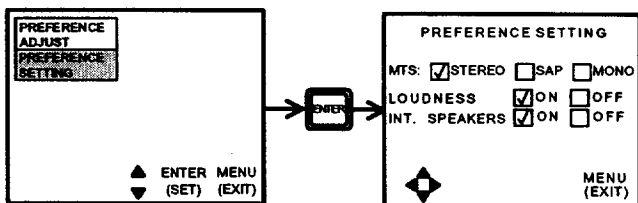

Use the CURSOR ▲, ▼ to select a function. The function will be in yellow.

Use the CURSOR ◀, ▶ to change function. Your choice will be in red.

**MTS MODE** (Multi-Channel Television Sound) will allow you to select STEREO (a stereo broadcast), SAP (second audio program) which may be a secondary language, weather report, etc. or MONO (monaural sound) used when receiving a weak stereo broadcast.

The sources received will be displayed below the channel number. The source you select will be displayed to the left of the channel number. See example below for each selection when both stereo and second audio are received (monaural is always received).

STEREO SELECTED



SAP SELECTED

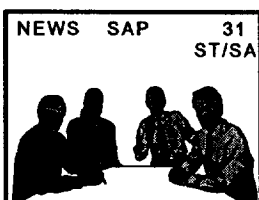

MONO SELECTED



## LOUDNESS

This function will improve the quality of both low and high frequency sounds when listening at low volume levels.

## INT. SPEAKERS

This function is useful when first setting up the external speakers, or if you prefer to use only speakers from a separate stereo system.



## CARE OF YOUR HITACHI PROJECTION TV AND YOUR REMOTE CONTROL

---

### DO

Dust the screen and cabinet with a soft cloth.

Clean the screen with a soft cloth moistened in warm water. Dry with a soft cloth. (A mild soap may be used if the screen is extremely dirty.)

Place your TV and remote control away from extreme heat, humidity and extremely dusty places.

Remove the plug from the wall outlet if your television set will not be used for a long period of time, for instance, when you go on vacation.

### DO NOT

Do not clean your screen or cabinet with strong cleaners, polishes or a chemically treated cloth.

Do not place rubber or vinyl products or cellophane tape on your set.

Do not touch the screen too often.

Do not subject the Remote Control to shocks such as dropping it on the floor, etc. Physical damage to the precision parts may result.

Avoid placing the Remote Control in a high humidity place or getting it wet. Do not leave it on or near a heater. Excessive heat or moisture may cause the unit to cease operation.

When the batteries run down, remote control operation will become erratic or possibly stop altogether. Replace the old batteries with fresh "AA" size batteries.

Exposure of the viewing screen to prolonged direct sunlight or heat may cause the screen to permanently warp, resulting in a distorted picture.



## RECEPTION PROBLEMS



• **IGNITION NOISE:**

Black spots or horizontal streaks may appear, picture may flutter or drift. Usually caused by interference from automobile ignition systems, neon lamps, electrical drills and other electrical appliances.



• **GHOSTS:**

Ghosts are caused by the television signal following two paths. One is the direct path and the other is reflected from tall buildings, hills or other objects. Changing the direction or position of the antenna may improve reception. Ghosting may also be caused by defects in the antenna system such as unshielded leads or connecting several sets to the same antenna without using multiple antenna couplers.

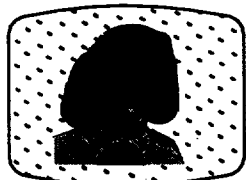

• **SNOW:**

If your receiver is located in the fringe area of a television station where the signal is weak, your picture may be marred by the appearance of small dots. When the signal is extremely weak, it may be necessary to install a special antenna to improve the picture.



• **RADIO FREQUENCY INTERFERENCE:**

The interference produces moving ripples or diagonal streaks, and in some cases, causes loss of contrast in the picture.



## CHECK HERE BEFORE CALLING FOR SERVICE

SYMPTOMS	<b>CHECK THESE ITEMS AND TRY THESE ADJUSTMENTS</b>												
	Be sure external connection is correct	Be sure power cord is plugged in	Be sure TV is switched "ON"	Try another channel (station trouble)	Check antenna connections (back of TV)	Check antenna for broken lead-in wire	Check outside antenna	Adjust for local interference	Adjust Contrast control	Adjust Brightness control	Adjust Color control	Adjust Tint control	Adjust Volume control
No picture, no sound	●	●	●	●	●	●	●						
Sound OK, picture poor	●			●	●	●	●	●	●				
Picture OK, sound poor	●			●	●	●	●	●				●	
Picture blurred	●			●	●	●	●	●					
Lines or streaks in picture				●	●	●	●	●					
Poor reception on some channels				●	●	●	●	●					
Picture rolls vertically				●				●					
No Color	●			●	●	●	●			●			
Poor color	●			●	●	●	●			●	●		

This Projection Television incorporates advanced power surge protection technology designed to protect against component or circuit damage due to external or internal voltage or power surges.

IF YOUR SET SHOULD APPEAR TO HAVE A LOSS OF POWER, PLEASE FOLLOW THIS PROCEDURE:

- 1) Push the power switch (ON/OFF switch) once.
- 2) If there is still no power, wait 30 seconds and push the power switch again.
- 3) If there is still no power, unplug the power cord from the wall. Wait thirty seconds and plug the power cord back in. Push the power switch again.

This protective technology should provide for years of lasting entertainment from your Projection Television.





# SPECIFICATIONS

## Features:

- Superfine Picture Quality
  - 750 Line Horizontal Resolution
- Pure Green and Red Filter Lenses
- Artificial Intelligence System
- Remote (Controls many VCR brands and cable boxes)
- Easy Graphic Guide On -Screen Display
- Full set of Input Jacks, Including S-Video
- Closed Caption Decoder
- High Resolution Picture-In-Picture
- Tuned Port Bass Reflex Speakers

## Inputs:

- Power Input ..... AC 120V, 60 Hz
- Power consumption (operating)
  - 50EX20B ..... 154W
  - 60EX38B ..... 154W
- Power consumption (maximum)
  - 50EX20B ..... 210W
  - 60EX38B ..... 210W
- Antenna input impedance ..... 75 Ohm
- Channel coverage ..... 181 ch.
  - VHF-Band ..... 2-13
  - UHF-Band ..... 14-69
  - CATV Mid Band ..... A-5~A-1
  - A-I
  - Super Band ..... J-W
  - Hyper Band ..... W+1-W+28
  - Ultra Band ..... W+29-W+84
- Video ..... 1.0Vp-p, 75 Ohm
- S-Video
  - Luminance (Y) ..... 1.0Vp-p, 75 Ohm
  - Chrominance (C) ..... 0.286Vp-p, 75 Ohm
- Audio input impedance ..... 47k Ohm
- Average input level ..... 470mVrms
- Maximum input level ..... 940mVrms

## Outputs:

- Video ..... 1.0Vp-p, 75 Ohm
- Audio (fixed) ..... 470mVrms, 1k Ohm

## Dimensions:

	50EX20B	60EX38B
• Height (in.)...	50 <sup>7</sup> / <sub>8</sub>	60 <sup>7</sup> / <sub>16</sub>
• Width (in.)...	41 <sup>5</sup> / <sub>8</sub>	51 <sup>3</sup> / <sub>8</sub>
• Depth (in.)...	23 <sup>5</sup> / <sub>8</sub>	29 <sup>9</sup> / <sub>16</sub>
• Weight (lbs.)...	185	223

NOTE: Due to improvements, specifications in this operating guide are subject to change without notice.



## USEFUL INFO

# HITACHI

# Service hotline

To locate an authorized  
HITACHI service facility  
in the continental U.S.A  
and Canada,

## DIAL TOLL FREE

7 days a week, 24 hours a day

# 800 HITACHI

(1-800-448-2244)

### Hitachi Home Electronics (America), Inc.

Hitachi has made every effort to assure you hours of trouble free operation from your unit. However, should you require service, a network of Hitachi Authorized Service Facilities has been established in all 50 states and Puerto Rico. Each facility will provide you with convenient and expedient assistance. Our service hotline operator will direct you to the Hitachi Authorized Service Facility nearest you. Just present proof of purchase and/or delivery receipts to the Hitachi Authorized Service Facility, and service will be rendered in accordance with the terms of the limited warranty as stated on your warranty card or operating guide.

*Should you have any questions regarding warranty, service, operation, or technical assistance, please contact:*

**Hitachi Home Electronics (America), Inc.**  
3890 Steve Reynolds Blvd.  
Norcross, GA 30093  
Tel: 770-279-5600

**Hitachi Sales Corporation of Hawaii**  
3219 Koapaka St.  
Honolulu, HI 96819  
Tel: 808-839-3621

*For TVs purchased in Canada only, please contact one of the Hitachi offices below, should you have any questions regarding service, operation, or technical assistance.*

**MONTREAL**  
9425 Trans Canada  
Saint-Laurent, Quebec  
H4S 1V3

Tel: (514) 956-9882  
Fax: (514) 956-9761

**TORONTO**  
6740 Campobello Road  
Mississauga, Ontario  
L5N 2L8

Tel: (905) 821-4545  
Fax: (905) 826-6627

**VANCOUVER**  
20800 Westminster Hwy., Unit 1103  
Richmond, B.C.  
V6V 2W3

Tel: (604) 214-0777  
Fax: (604) 214-0772

# INDEX



Accessories .....	6	Remote Control	
AI (Artificial Intelligence) .....	9,33,34	Cable Box Functions .....	21
Antenna .....	7,8,10	Picture in Picture .....	18
Audio		Sensor .....	9
Preference Adjust .....	36	TV Functions .....	15
Preference Setting .....	37	VCR Functions .....	20
Audio to Hi-Fi .....	10	Reset .....	17,33,36
Audio System Setup .....	13	S-Video .....	8,10,12,34
AVX .....	9,10,16,18	Safety Tips .....	2,3,4
Battery Replacement .....	6,38	SA,SAP .....	15,37
Cable Box Codes .....	21,22	Service Hotline .....	42
Cables, Hook up .....	8	Service .....	4,42
Care for your TV and Remote .....	38	Set Up	
CATV .....	4,8,21,22,25	Air/Cable .....	25
Channel .....	9,16	Auto Program .....	26
Clock		Channel Memory .....	26
Message-1,2 .....	32	Closed Caption .....	27
Calendar .....	32	Menu Language .....	27
Clock Set .....	31	Shift .....	19
On/Off timer .....	15,31	Speaker, Rear .....	10,11,12,13
Connections,		Specifications .....	41
Antenna .....	4,8,10	Surround Switch .....	10,17
Rear Panel .....	10,11	Swap .....	18
Cursor .....	16,23	Twin Lead Connector .....	8
Easy Graphic Guide .....	23	UHF/VHF .....	8,25
Enter .....	16,23	VCR Codes .....	20,22
F-Connector .....	8	Video	
Freeze .....	19	Convergence Adjust .....	35
Front Panel Controls .....	9	Preference Adjust .....	33
Important Safeguards .....	2,3,4	Preference Setting .....	34
Jacks		Volume .....	9,17
Rear Panel .....	10		
Light Button .....	14		
Location, Viewing .....	3,7,38		
LST-CH .....	17		
Menu .....	9,16,23		
Mono Sound .....	12,37		
Mute .....	17,27		
PIP (Picture in Picture) .....	17,18		
Phono Connector .....	8		
Picture Cautions .....	5		
Power			
Light .....	9		
Button .....	9,15		
Program			
Channel Caption .....	28		
Child Lock .....	28		
Program List .....	29		
Volume Correction .....	30		
Quick Freeze .....	19		
Rear Speaker Connections .....	12		
Recall .....	15		
Reception			
Band .....	25		
Problems .....	39		

**HITACHI**