

**INSTALLATION  
INSTRUCTIONS**

*500 Series*

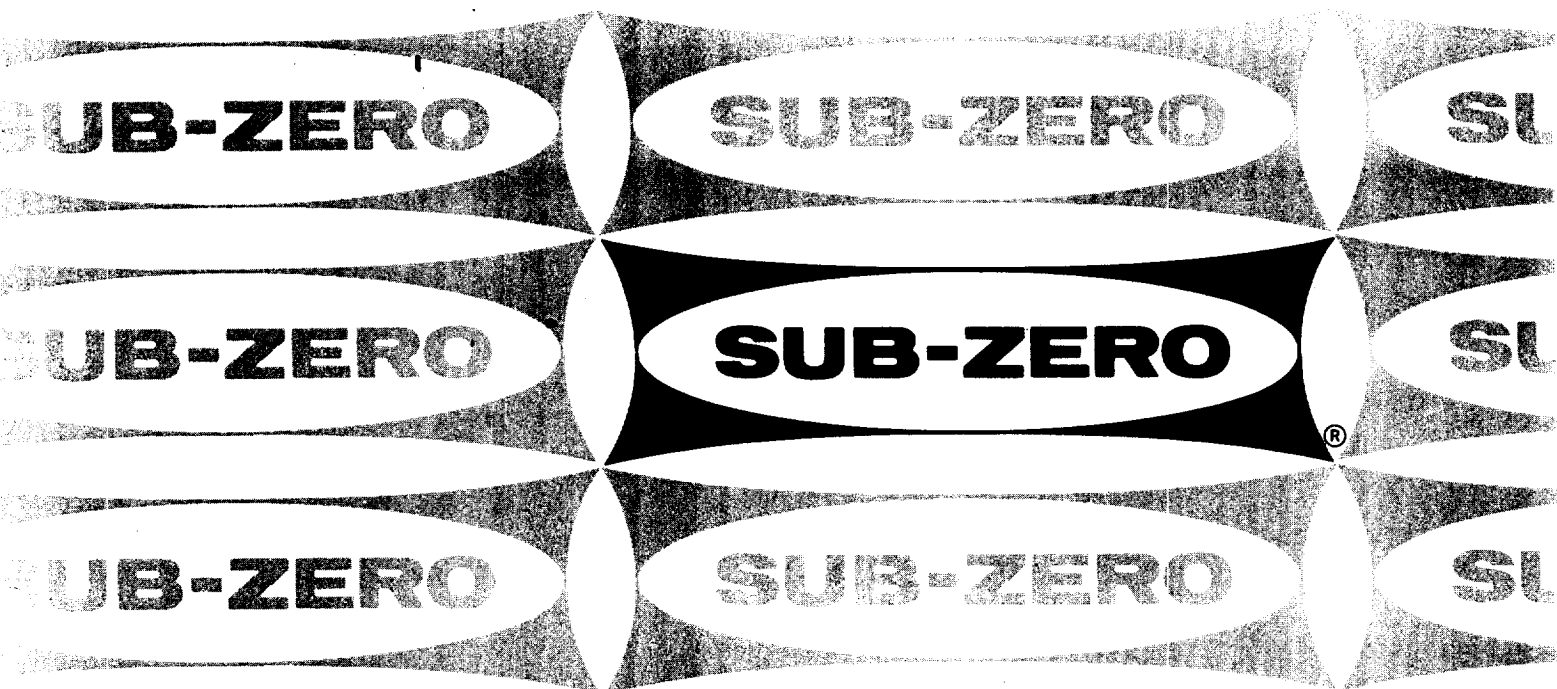

# 500 Series

## PRE-INSTALLATION INSTRUCTIONS

### PREPARATION FOR INSTALLATION

#### Step 1

Prepare the finished rough opening to accept the installation of the Sub-Zero.

**NOTE: Carefully read the "Pre-Installation Specifications" chart below.**



## PRE-INSTALLATION SPECIFICATIONS

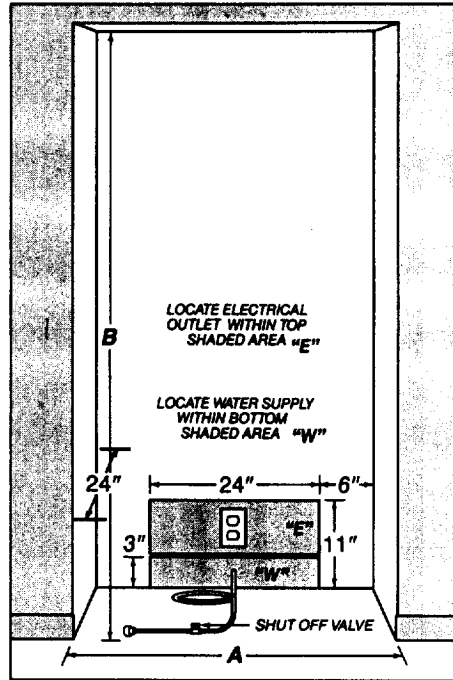

MODELS 501F AND 501R

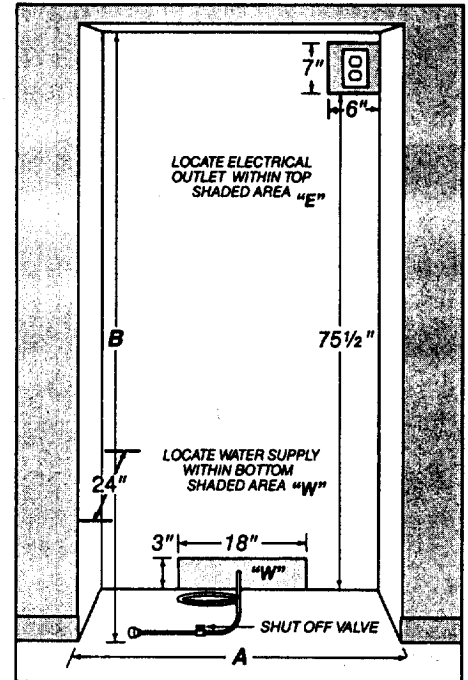

Figure 1

MODELS 511, 532, 542, 550, 561 AND 590

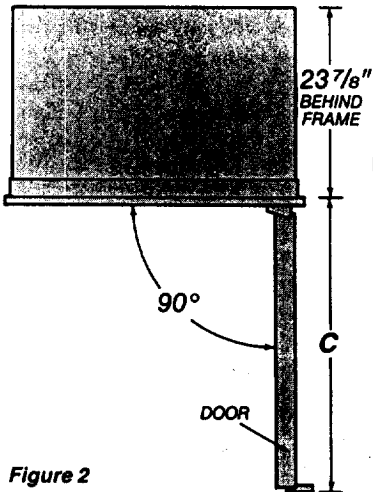

Figure 2

MODEL	FINISHED ROUGH OPENING DIMENSIONS		DOOR PANEL DIMENSIONS (WIDTH x HEIGHT) **	MINIMUM DOOR CLEARANCE REQUIRED AT 90° C	MINIMUM HEIGHT REQUIRED (with levelers in)
	A*	B			
501F	35 1/2"	72 3/4"	34 1/8" x 58 15/16"	36 1/16"	72 7/16"
501R	35 1/2"	72 3/4"	34 1/8" x 58 15/16"	36 1/16"	72 7/16"
511	29 1/2"	83 3/4"	28 1/8" x 48 1/16" 28 1/8" x 18 3/8"	30 1/16"	82 7/8"
532	47 1/2"	83 3/4"	17 15/16" x 67 11/16" 27 11/16" x 67 11/16"	29 1/4"	82 7/8"
542	41 1/2"	83 3/4"	15 5/8" x 67 11/16" 24" x 67 11/16"	25 9/16"	82 7/8"
550	35 1/2"	83 3/4"	34 1/8" x 48 1/16" 34 1/8" x 18 3/8"	36 1/16"	82 7/8"
561	35 1/2"	83 3/4"	14 5/8" x 67 11/16" 19 1/8" x 67 11/16"	20 3/4"	82 7/8"
590	47 1/2"	83 3/4"	15 1/8" x 67 11/16" 20 9/16" x 67 11/16" Grille Panel: 9 3/16" x 46 3/16"	29 1/4"	82 7/8"

(Handle Trim Panels not to exceed .050" thickness)  
 Refrigerator, Upper Trim Panel: 6 7/8" x 25 7/32"  
 Refrigerator, Lower Trim Panel: 6 7/8" x 31 7/32"  
 Freezer Trim Panel: 2 9/16" x 67 11/32"

\*When units are installed side by side, a separating filler strip is recommended. The filler strip width should be added to the finished rough opening dimension. A filler strip must also be used when units are installed hinge to hinge.

\*\*Routing or Recessing may be required on raised panels for finger clearance under handle. Refer to Figures 28 and 29 — "Handle Recess Specs and Recommendations for Raised Panels."

# PRE-INSTALLATION INSTRUCTIONS

## AREA PREPARATION

### Step 2

When units are installed side by side, a separating filler strip is recommended. The filler strip width should be added to the finished rough opening dimension. A filler strip must also be used when units are installed hinge to hinge.

**IMPORTANT: For proper operation and use the door must open a minimum of 90°. A minimum 2" filler must be used in corner installations to assure a 90° door opening. Remember to allow enough clearance in front of unit for full door swing. Minimum door clearance listed in Figure 2.**

**IMPORTANT NOTE: We also require the floor under the refrigerator to be at the same level as the surrounding finished floor.**

### CAUTION

**Any finished flooring should be protected with appropriate material to avoid damage from very heavy appliance.**

If unit fits under soffit with clearance between top of unit and soffit of 1" or less as in Figure 3 unit does not require blocking, otherwise blocking is required. Refer to step 8.

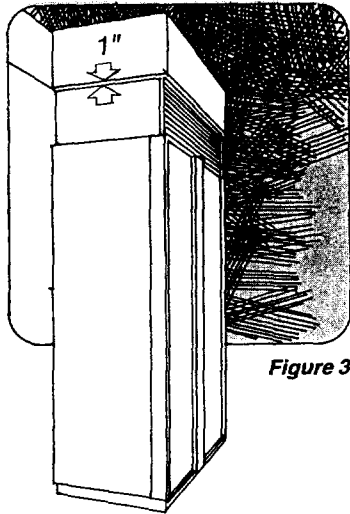

Figure 3

## ELECTRICAL INSTRUCTIONS

### Step 3

Rough in the electrical outlet following the "Pre-Installation Specifications". See Figure 1.

A 115 volt, 60 Hz, 15 amp fused electrical supply is required. It is recommended that a separate circuit, serving only this appliance, be provided.

Follow any other local codes or ordinances that may also apply.

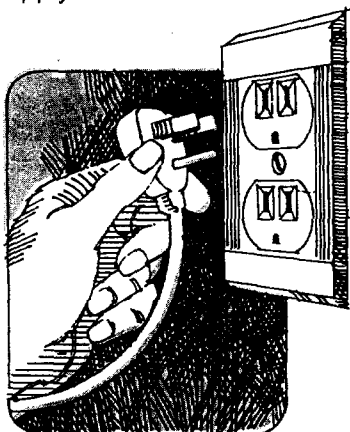

Figure 4

### WARNING

**Do not use an extension cord, or two prong adapter. Electrical ground is required on this appliance.**

**Do not under any circumstances remove the power supply cord ground prong.**

This appliance is factory equipped with a power supply cord with a 3-prong grounding plug. It must be plugged into a mating 3-prong grounding type wall receptacle grounded in accordance with the National Electrical Code and local codes and ordinances. See Figure 4.

## PLUMBING INSTRUCTIONS

### Step 4

For units with automatic icemaker, rough in the water supply line.

Connect a 1/4" copper line to the house supply being sure to use an easily accessible shut off valve between the supply and your refrigerator (approximately 6" from the compression fitting). The icemaker operates on water pressure of 20 to 100 PSI.

**NOTE: A line filter is required when water conditions have a high sediment content. Do not use "self piercing" valves. Saddle valve kit (part #4-20-088-0) available from your distributor.**

Route the water line up thru the floor within 1/2" from wall, no higher than 3" from floor when routed under unit. See Figure 5.

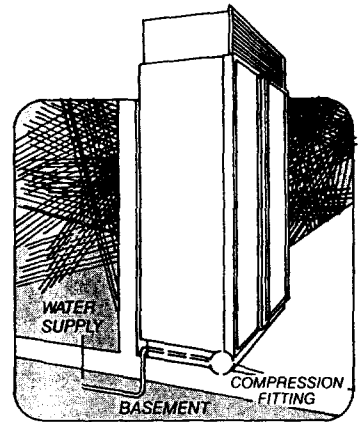

Figure 5

Route the water line thru the wall no more than 3" from floor when routed under unit. See Figure 6.

**NOTE: Regardless of the routing, allow for at least 3 feet of excess copper tubing to remain outside wall or floor for easy connection to the unit.**

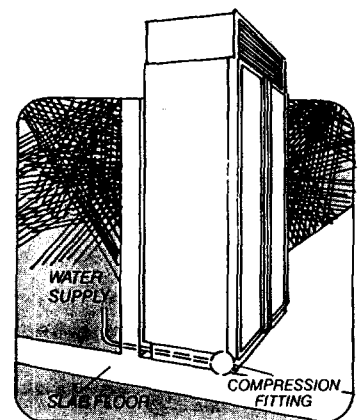

Figure 6

## UNPACKING

### Step 5

Uncrate unit, remove wood base and discard the shipping bolts which secure the wood base to the bottom of the unit. Do not discard wood block and hardware to be used for blocking your unit.

In addition retract front leveler legs to ensure easier movement of the unit for installation.

# 500 Series

## INSTALLATION INSTRUCTIONS

### ▲WARNING

To reduce the possibility of the unit tipping forward, you must reposition the front levelers to make contact with the floor. You will have to extend these legs when the unit is finally positioned.

**Step 6**  
Remove all packing materials and tape.

### GRILLE REMOVAL

**Step 7**  
Grille removal is necessary to access power cord, hook up water line and is recommended for transporting through doorways.

#### MODELS 511, 532, 542, 550 AND 561

Remove center grille screw and cut the red nylon shipping strap. Tilt the grille forward and release the spring(s) from behind the grille. See Figure 7.

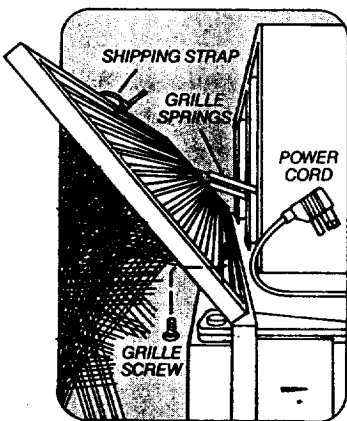

Figure 7

#### MODELS 501F AND 501R

To remove the 501 grille, remove two (black) screws located in the lowest louver in the grille. Tilt the bottom of the grille out and away, it will release from the top of the grille. There is no grille spring on 501 Series. See Figure 8.

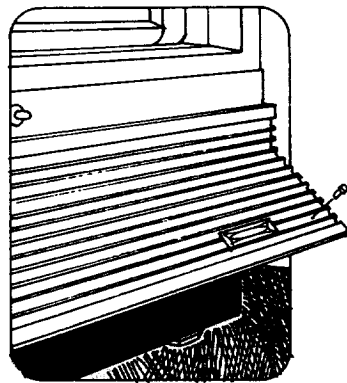

Figure 8

#### MODEL 590

To remove Model 590 grille assembly, the inner grille panel assembly must first be removed. Lift up (1), then pull out at the bottom (2), then pull top section down and out of the top key slot (3) (as in Figure 9). Next, remove the 5 mounting screws that hold the outer grille panel assembly to the top compartment. See Figure 10.

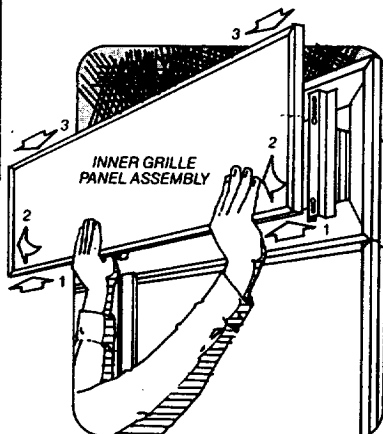

Figure 9

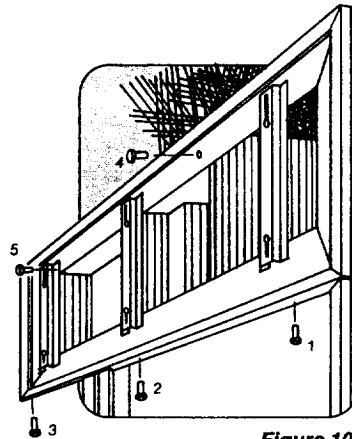

Figure 10

### BLOCKING (ALL MODELS) Step 8

#### ▲WARNING

To help prevent the unit from tipping forward under certain load conditions and provide a more stable installation, the unit must be secured in place with a solid soffit or wood block.

If there is a solid soffit above the unit with clearance between the unit and the soffit of one inch or less, as illustrated in Figure 3, you do not need to block the unit. If this is not the case, YOU MUST BLOCK THE UNIT.

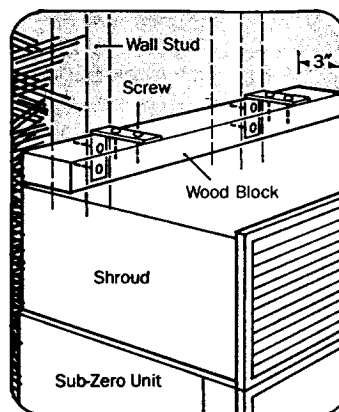

Figure 11

To block the unit, using the wood block and hardware provided, follow these steps.

- 1) Locate and mark two wall studs against the wall where the refrigerator is to be located.
- 2) Locate the proper height to clear the unit. The space along the top of the Sub-Zero and the bottom of the wood block **must not be greater than 1/4"**. See Figure 11.
- 3) Position the wood block over the unit and secure it using the screws and "L" brackets provided. Make sure screws extend a minimum of 7/8" into each of the two wall studs. The wood block must extend a minimum of three inches over the unit. See Figure 11.
- 4) Using the front and rear levelers, the unit must be raised until it contacts the wood block. See Figure 12.

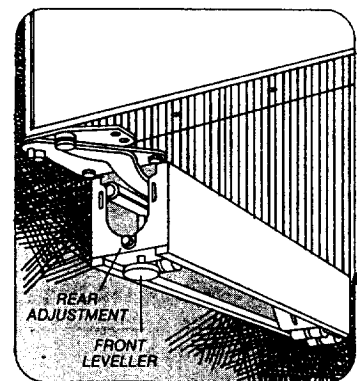

Figure 12

#### ▲WARNING

To reduce possibility of cabinet tipping forward, front levelers must be in contact with floor. See Figure 12.

# INSTALLATION INSTRUCTIONS

## INSTALLATION

### ⚠ WARNING

Shut-off power to the wall outlet.

### Step 9

Unit is equipped with rollers. Plug into 15 amp grounded outlet and roll unit into desired position under the wood block or soffit and connect icemaker water line to unit. Remove garden hose fitting from plastic bag and attach the 1/4" compression nut and sleeve on copper tubing before attaching the hose fitting to the solenoid valve. Purge line before final hookup to valve. See Figure 13. For Model 590 see Figure 14.

Turn on water supply and check all fittings for leaks. Make certain electrical harness is attached to solenoid.

**NOTE: Icemaker will not immediately fill with water when supplied to valve. Allow 24 hours for proper ice production.**

MODELS 511, 532, 542, 550, 561 AND 501F

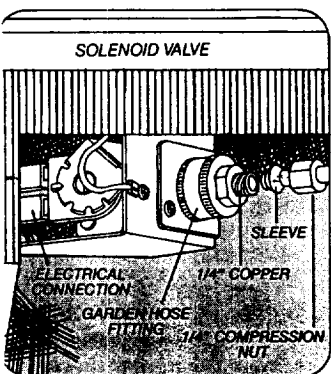

Figure 13

MODEL 590

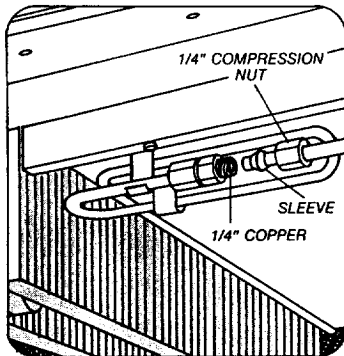

Figure 14

### Step 10

Level the unit. To adjust height, turn front leveling legs counterclockwise to raise, or clockwise to lower. Rear levellers (rollers) are adjusted from front of base. Turn 5/16" hex bolt clockwise to raise cabinet, counterclockwise to lower cabinet. See Figure 12.

### Step 11

Install toe plate as shown in Figure 15.

Before attaching toe plate check to ensure drain pan is installed properly.

### ⚠ CAUTION

Toe plate must be removable for servicing, so any flooring must allow for this removal. Refer to label mounted on kickplate support for height clearance.

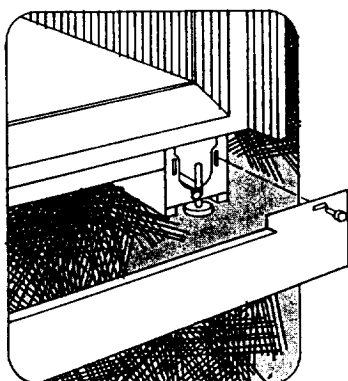

Figure 15

### Step 12

Install grille, step 7.

**IMPORTANT: For Models 511, 532, 542, 550, 561 and 590, reverse step 7 procedure. NOTE: If using panelized grille refer to "Grille Panel Installation."**

### Step 13

Restore power to the wall outlet.

## PANEL INSTALLATION

### Step 14

Apply decorative front panels (and side panels if applicable).

All Sub-Zero units are manufactured in a manner to achieve a total built-in appearance. This allows you to choose the decorative material and color application for the front and sides (if exposed) for your refrigerator/freezer.

## FRONT PANEL INSTALLATION

(See "Pre-Installation Specifications" — for panel dimensions)

If a metal or other thin material is used, a filler must be inserted behind your panel to insure a proper fit. All frames are designed to accept up to 1/4" material. If a raised, wood front panel is being used, the edges must be routed to the necessary 1/4" border specifications. (50# per door panel maximum weight limit)

**NOTE: ROUTING, RECESSING OR OPTIONAL EXTENDED HANDLES MAY BE REQUIRED ON RAISED PANELS FOR FINGER CLEARANCE UNDER HANDLE.** Refer to Figures 28 and 29 — "Handle Recess Specifications and Recommendation for Raised Panels."  
**NOTE: does not apply to Model 590.**

MODELS 501F, 501R, 511, 532, 542, 550 AND 561

**A)** To install front panels on your Sub-Zero, the door handles must be removed. The handle screws are hidden by a magnet backed trim molding. Remove the molding using a piece of tape to pull it away from the handle and expose the handle screws. **NOTE: the molding will bend at center allowing removal as in Figure 16.**



Figure 16

# 500 Series

## INSTALLATION INSTRUCTIONS

**B)** With standard Phillips screwdriver, remove door handle on freezer and refrigerator door (the door handles also act as a door trim). The Models 511 and 550 freezer door handle isw on the top of the door and removed in the same manner described above.

**C)** Slide panel into frame on door as shown in Figure 17.

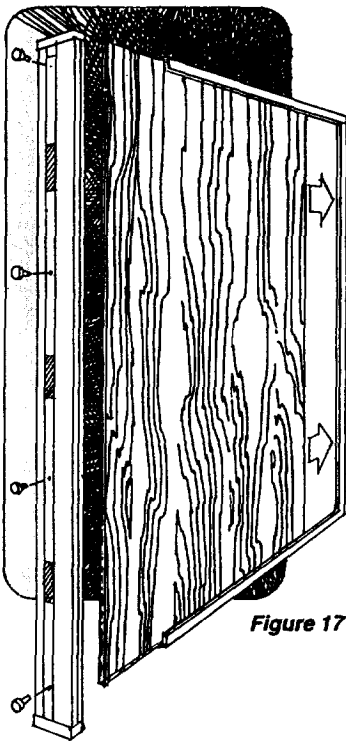

Figure 17

**D)** With panel in position, replace handle and screws. Replace the trim molding(s) by inserting the top and then the bottom into the handle channel. Release the middle and set the magnets.

### MODEL 590

**A)** To install panels on the Model 590, the door handle and door handle trim must first be removed. The screws are hidden by a magnet-backed trim molding. Remove the molding using a piece of tape to pull it away from the handle and expose the handle screws.

**NOTE: The trim molding will bend out at the center allowing removal as shown in Figure 16.**

**B)** With standard Phillips screwdriver, remove door handles on freezer and refrigerator doors (door handles also act as a door trim, see Figure 17).

**C)** Remove the handle trim panels by sliding them out of the door(s). See Figure 18.  
**NOTE: Different colored handle trim panels and glasswells are available through your product distributor.**

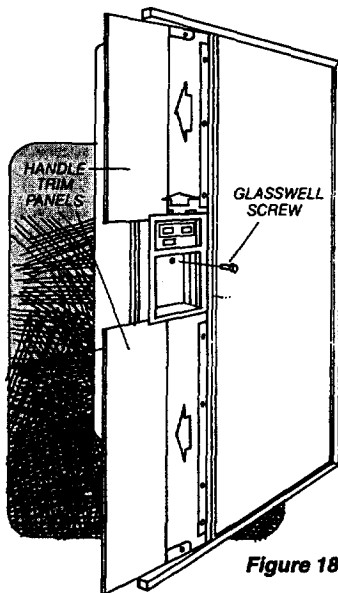

Figure 18

**D)** Next, remove the water and ice glasswell by removing the mounting screw. Then slide the glasswell up and pull out as in Figure 18.

**E)** Remove the top and bottom trim fillers held on by the mounting screw(s). See Figure 19.

**F)** Remove the screws holding in vertical trim strip. See Figure 19.

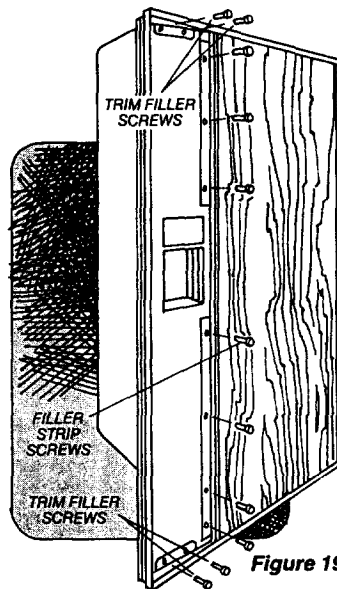

Figure 19

**G)** Install door panels by sliding into frame on door as shown in Figure 17.

**H)** With door panels in place, reverse the steps for proper reassembly.

**NOTE: If replacing standard handle insert panels and glasswell with original or custom handle insert panel or glasswell, refer to step H.**

## GRILLE PANEL INSTALLATION

If optional EA panel grille is purchased for Models 511, 53, 542, 550 or 561, follow these instructions.

EA GRILLE PANEL SIZE	
Grille Size	Panel Size
10 x 30	8 <sup>3</sup> / <sub>16</sub> x 28 <sup>3</sup> / <sub>16</sub>
11 x 30	9 <sup>3</sup> / <sub>16</sub> x 28 <sup>3</sup> / <sub>16</sub>
12 x 30	10 <sup>3</sup> / <sub>16</sub> x 28 <sup>3</sup> / <sub>16</sub>
13 x 30	11 <sup>3</sup> / <sub>16</sub> x 28 <sup>3</sup> / <sub>16</sub>
14 x 30	12 <sup>3</sup> / <sub>16</sub> x 28 <sup>3</sup> / <sub>16</sub>
15 x 30	13 <sup>3</sup> / <sub>16</sub> x 28 <sup>3</sup> / <sub>16</sub>
10 x 36	8 <sup>3</sup> / <sub>16</sub> x 34 <sup>3</sup> / <sub>16</sub>
11 x 36	9 <sup>3</sup> / <sub>16</sub> x 34 <sup>3</sup> / <sub>16</sub>
12 x 36	10 <sup>3</sup> / <sub>16</sub> x 34 <sup>3</sup> / <sub>16</sub>
13 x 36	11 <sup>3</sup> / <sub>16</sub> x 34 <sup>3</sup> / <sub>16</sub>
14 x 36	12 <sup>3</sup> / <sub>16</sub> x 34 <sup>3</sup> / <sub>16</sub>
15 x 36	13 <sup>3</sup> / <sub>16</sub> x 34 <sup>3</sup> / <sub>16</sub>
10 x 42	8 <sup>3</sup> / <sub>16</sub> x 40 <sup>3</sup> / <sub>16</sub>
11 x 42	9 <sup>3</sup> / <sub>16</sub> x 40 <sup>3</sup> / <sub>16</sub>
12 x 42	10 <sup>3</sup> / <sub>16</sub> x 40 <sup>3</sup> / <sub>16</sub>
13 x 42	11 <sup>3</sup> / <sub>16</sub> x 40 <sup>3</sup> / <sub>16</sub>
14 x 42	12 <sup>3</sup> / <sub>16</sub> x 40 <sup>3</sup> / <sub>16</sub>
15 x 42	13 <sup>3</sup> / <sub>16</sub> x 40 <sup>3</sup> / <sub>16</sub>
10 x 48	8 <sup>3</sup> / <sub>16</sub> x 46 <sup>3</sup> / <sub>16</sub>
11 x 48	9 <sup>3</sup> / <sub>16</sub> x 46 <sup>3</sup> / <sub>16</sub>
12 x 48	10 <sup>3</sup> / <sub>16</sub> x 46 <sup>3</sup> / <sub>16</sub>
13 x 48	11 <sup>3</sup> / <sub>16</sub> x 46 <sup>3</sup> / <sub>16</sub>
14 x 48	12 <sup>3</sup> / <sub>16</sub> x 46 <sup>3</sup> / <sub>16</sub>
15 x 48	13 <sup>3</sup> / <sub>16</sub> x 46 <sup>3</sup> / <sub>16</sub>

The frame molding is designed to hold 1/4" thick panel. Raised wood panels must be routed to 1/4" thickness on all four sides to provide a 1/4" lip. (15 lbs. maximum panel weight.)

# INSTALLATION INSTRUCTIONS

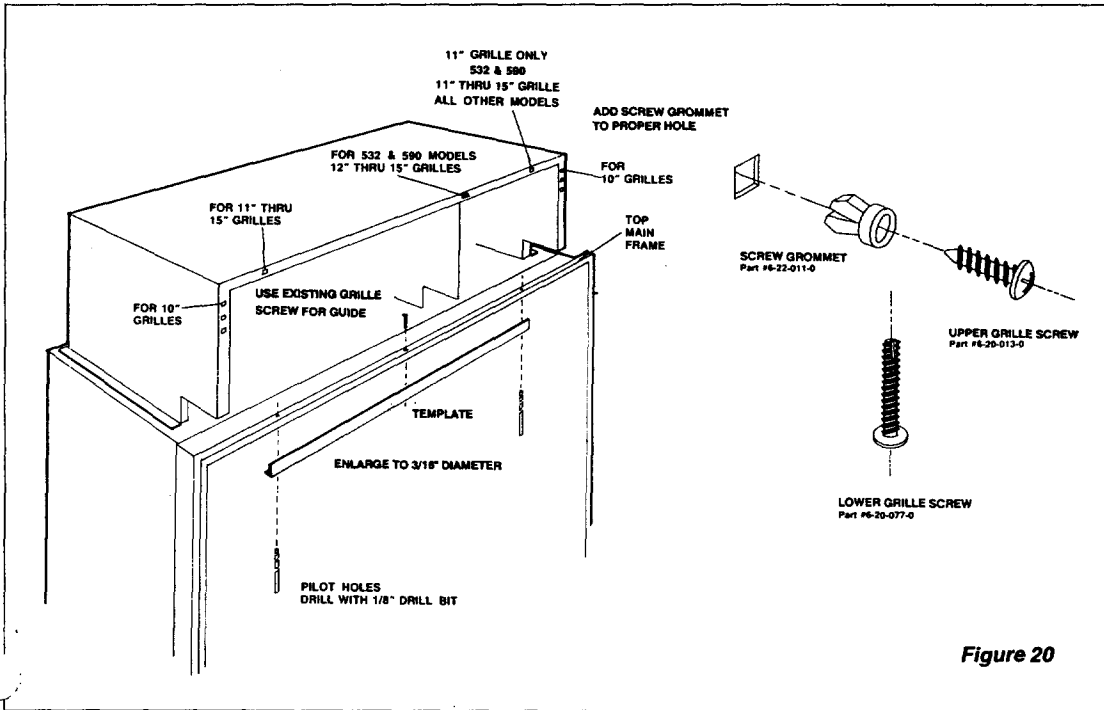

Figure 20

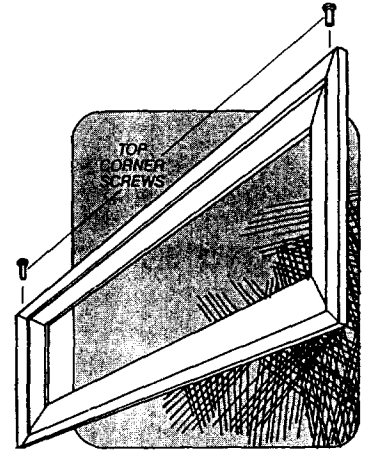

Figure 21

**C)** Slide panel into position in grille frame as shown in Figure 22.  
**NOTE:** When using 1/4" or less, a filler is necessary.

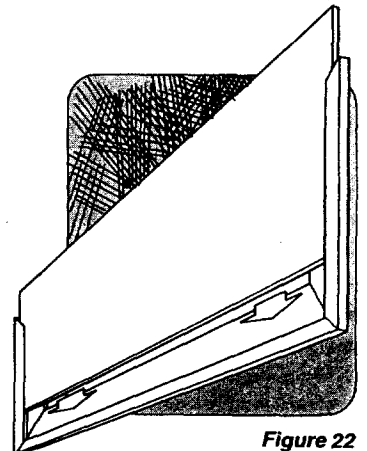

Figure 22

**A)** Remove louvered grille. Refer to step 7.

**B)** Open the door(s) and attach template provided with panel grille installation kit. The template center hold must be aligned with the grille screw hole and you must fasten from the top down with the screw you removed in step A. See Figure 20.

**C)** With template in place, drill 1/8" pilot holes in the end holes of the template. See Figure 20. Enlarge pilot holes by drilling 3/16" finished holes. After drilling holes, remove template and discard. Keep screw for later installation.

**D)** Install screw grommets in properly labeled holes in Figure 20 in the shroud assembly.

**E)** Attach the outer grille frame to the shroud assembly by inserting the two upper grille screws into their proper holes and with door(s) open install the lower three grille screws as shown in Figure 20 and Figure 10.

**F)** Refer to Model 590 grille installation, steps B through E, on this page for the remainder of the assembly.

## MODEL 590 (STANDARD FEATURE)

EA GRILLE PANEL SIZE	
Grille Size	Panel Size
10 x 48	8 <sup>3</sup> / <sub>16</sub> x 46 <sup>3</sup> / <sub>16</sub>
11 x 48	9 <sup>3</sup> / <sub>16</sub> x 46 <sup>3</sup> / <sub>16</sub>
12 x 48	10 <sup>3</sup> / <sub>16</sub> x 46 <sup>3</sup> / <sub>16</sub>
13 x 48	11 <sup>3</sup> / <sub>16</sub> x 46 <sup>3</sup> / <sub>16</sub>
14 x 48	12 <sup>3</sup> / <sub>16</sub> x 46 <sup>3</sup> / <sub>16</sub>
15 x 48	13 <sup>3</sup> / <sub>16</sub> x 46 <sup>3</sup> / <sub>16</sub>

**A)** Remove the inner grille panel assembly (refer to step 7).

**B)** Remove the top two corner screws and pull away the top frame. See Figure 21.

**D)** Reattach the top frame by reinstalling the two top corner screws.

**E)** Install inner grille panel assembly back onto product (refer to step 7).

# 500 Series

## INSTALLATION INSTRUCTIONS

### SIDE PANEL INSTALLATION

If side panels are being utilized, please check with your installer for installation methods or you may use one of the side panel installation methods shown in Figure 23.

Drill 3 holes equal distance apart in vertical section of aluminum frame and install pan head screws.

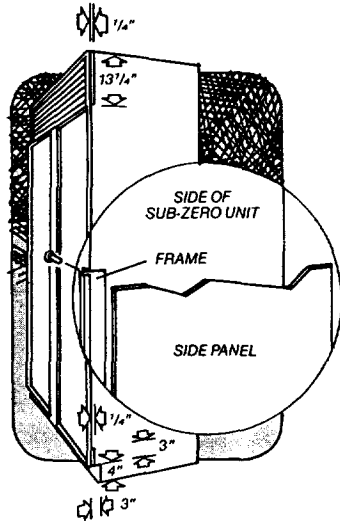

**NOTE:** Figure 23 is viewed from top edge of panel.

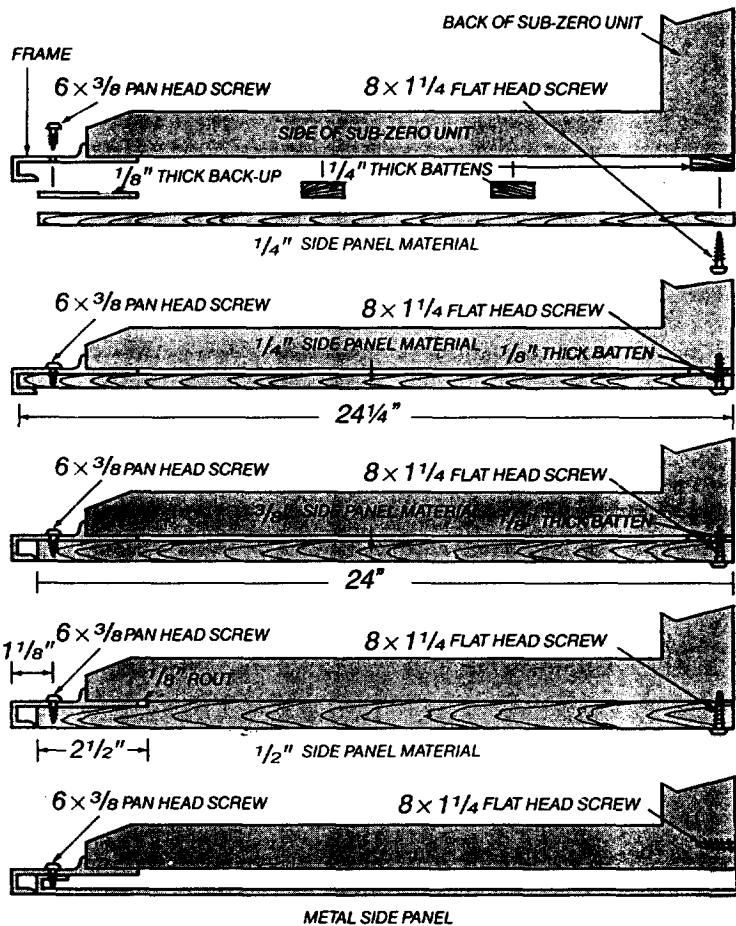

Figure 23

Anchor the side panel with decorative headed screws (as shown) or finishing nails can be used. The screws/nails must be obtained from your local hardware supply store.

**NOTE:** We do not recommend the use of adhesives.

Dimensions given for typical wood side panel installation. **NOTE:** If 1/4" (or less) panel is used and inserted into return channel extrusion then a 24 1/4" size is necessary for width. Sheet must also be notched for grille and other brackets or screws that are in the return channel. This is only necessary on this application.

### ANCHORING PRODUCT

#### Step 15

It is recommended after going through the previous procedures (front and side panel installation, leveling and alignment and door adjustment) proper anchoring of the unit to the opening be done as this will insure a proper installation.

**Sub-Zero Anchoring Kit #4-20-090-0 is available through your Product Distributor.**

Part #4-20-090-0 Contents:  
 6 1 1/4" Sems  
 3 3/16 x 1 Chicago Screw  
 Posts  
 1 6-19-023-0 Loctite

Figures 24 and 25 are examples.

**NOTE: Product(s) must be leveled and squared before attempting this procedure.**

**Instructions for product being tied together (see Figure 24):**

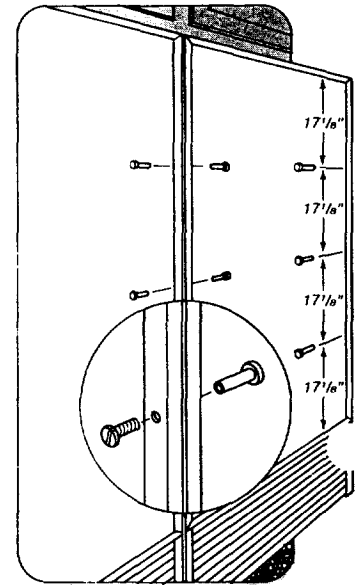

Figure 24

1) Drill three (3) 1 3/64" holes through the middle trim of both units.

#### CAUTION

**Do not drill through model and serial number tag.**



# INSTALLATION INSTRUCTIONS

- 2) Using the Loctite on the screws, install all 3 Chicago Screw Posts.
- 3) Inspect the units for level again.
- 4) Drill three (3)  $\frac{3}{16}$ " holes (per specs in Figure 24) through both outer trims.
- 5) Using a  $\frac{1}{8}$ " drill bit, drill into the cabinetry for a pilot hole.
- 6) Install all six (6) Sems to the cabinetry.

**Instructions for fastening Models 501R, 501F, 550, 511, 561, 532, 542 and 590 to cabinetry (see Figure 25):**

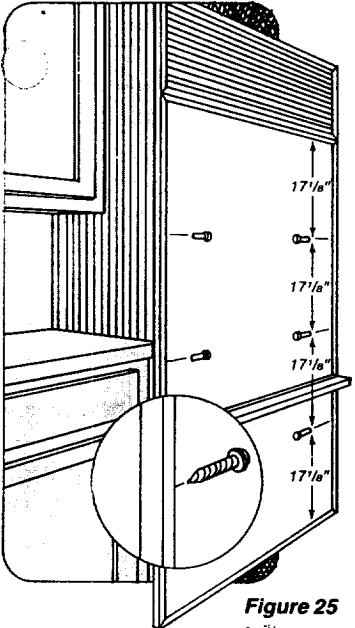

Figure 25

- 1) Drill three (3)  $\frac{3}{16}$ " holes (per specs in Figure 25) through both outer trims.
- 2) Drill a  $\frac{1}{8}$ " pilot hole into the cabinetry.
- 3) Install all six (6) Sems.

## HINGE ADJUSTMENT

**Step 16**  
If the doors are out of adjustment, the top or bottom hinge may be adjusted by removing and discarding the two small shipping screws. See Figure 26. The top door hinges can be adjusted left to right and in or out by loosening the three allen head screws. The bottom door hinge is equipped with two adjustment allen head screws. See Figure 27.

For adjustment, use a  $\frac{1}{8}$ " allen wrench to loosen screws (models 550 and 511 excluded). This allows the door to move left to right or in and out.  
**NOTE: On Models 532, 542, 561, 501R, 501F and 590 the doors open to 130°. An optional door stop kit (4-20-089-0), which allows a door opening of approximately 90° is available. Contact your distributor.**

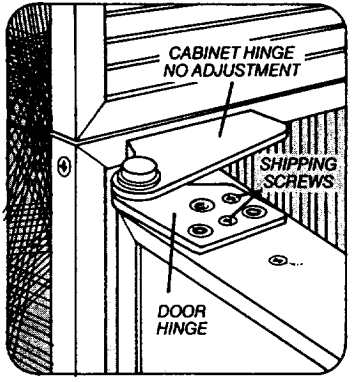

Figure 26

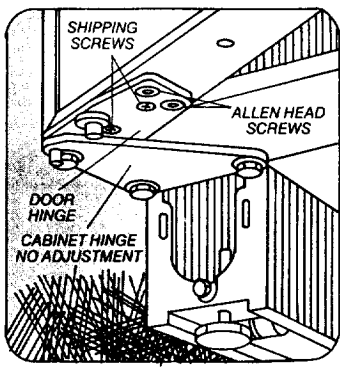

Figure 27

## INSTALLATION CHECK LIST

The importance of the installation of your Sub-Zero cannot be overemphasized. **The proper installation of your unit is the responsibility of the selling dealer or installer.** The following check list should be completed **by the installer** to insure no part of the installation has been overlooked. Any questions or problems pertaining to the installation should be directed to the selling dealer.

- Is unit operating? If not, is unit plugged in? Is refrigerator/freezer control on?
- Is packing material removed? (Step 6)
- Is water supply line connected to compression fitting? (Step 8)

### WARNING

**Disconnect power to unit before checking wiring connections.**

- Is blocking completed? (Step 8)
- Is unit leveled properly on a solid floor? (Step 10)
- Is blocking necessary? (Step 8)
- Is drain pan installed properly? (Step 11)
- Is toe plate installed? (Step 11)
- Is grille screw back in position? (Step 12)
- Are panels installed correctly? (Step 14)
- Are doors adjusted? (Step 16)
- Does the customer understand the unit's operation?
- Is the icemaker switch turned on? (Models 590, 532, 542 and 561).

**Give the customer the warranty packet.**

# 500 Series

## INSTALLATION INSTRUCTIONS

### STANDARD HANDLE RECESS SPECIFICATIONS

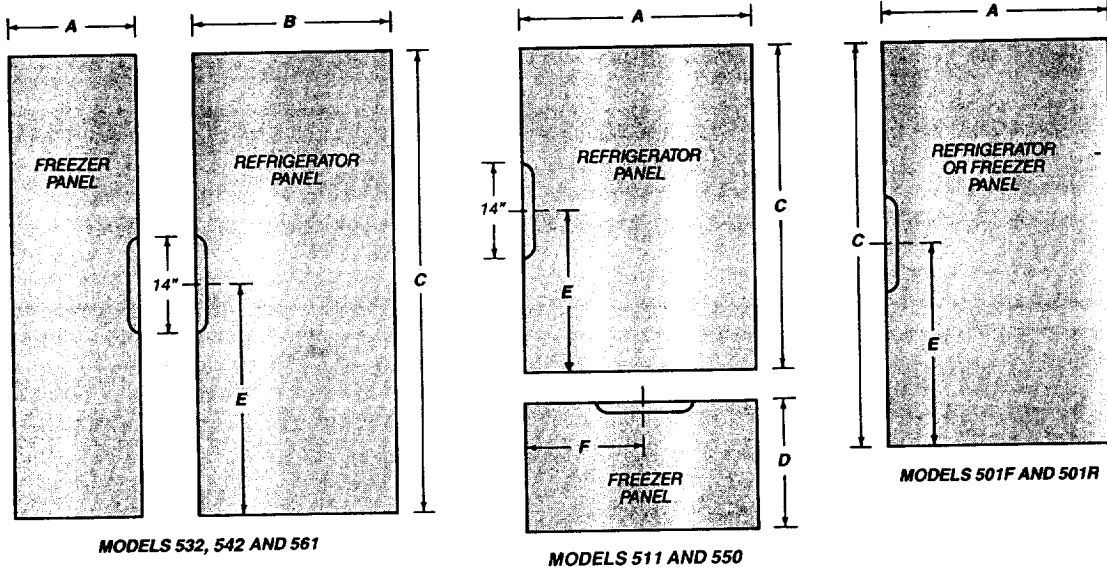

Figure 28

MODEL	A (WIDTH)	B (WIDTH)	C (HEIGHT)	D	E	F
532	17 <sup>15</sup> / <sub>16</sub> "	27 <sup>11</sup> / <sub>16</sub> "	67 <sup>11</sup> / <sub>16</sub> "		38 <sup>5</sup> / <sub>32</sub> "	
542	15 <sup>5</sup> / <sub>8</sub> "	24"	67 <sup>11</sup> / <sub>16</sub> "		38 <sup>5</sup> / <sub>32</sub> "	
561	14 <sup>5</sup> / <sub>8</sub> "	19 <sup>1</sup> / <sub>8</sub> "	67 <sup>11</sup> / <sub>16</sub> "		38 <sup>5</sup> / <sub>32</sub> "	
511	28 <sup>1</sup> / <sub>8</sub> "		48 <sup>1</sup> / <sub>16</sub> "	18 <sup>3</sup> / <sub>8</sub> "	24 <sup>1</sup> / <sub>32</sub> "	14 <sup>1</sup> / <sub>16</sub> "
550	34 <sup>1</sup> / <sub>8</sub> "		48 <sup>1</sup> / <sub>16</sub> "	18 <sup>3</sup> / <sub>8</sub> "	24 <sup>1</sup> / <sub>32</sub> "	17 <sup>1</sup> / <sub>16</sub> "
501F	34 <sup>1</sup> / <sub>8</sub> "		58 <sup>15</sup> / <sub>16</sub> "		29 <sup>15</sup> / <sub>32</sub> "	
501R	34 <sup>1</sup> / <sub>8</sub> "		58 <sup>15</sup> / <sub>16</sub> "		29 <sup>15</sup> / <sub>32</sub> "	
590	(Handle Recess Not Required)					

## PRODUCT SERVICE



**If you need service.** Take necessary steps to preserve food in unit. Door(s) should be left closed as much as possible until unit is back in service. Please have model and serial number available (for model and serial numbers refer to plate located on top frame of unit inside door). Call your nearest Sub-Zero Factory Authorized Service Center in your area, contact your dealer, or: Sub-Zero Freezer Co., Inc., Service Department, P.O. Box 44130, Madison, WI 53744-4130, Telephone 1-800-222-7820.

## PRODUCT INFORMATION

Telephone 1-800-222-7820

# INSTALLATION INSTRUCTIONS

## RECOMMENDATIONS FOR RAISED PANELS

Because of different door panel designs, routing, recessing, or use of optional extended handles may be necessary for finger clearance when using raised panels greater than 1/4" total thickness. (50# per door panel maximum weight limit.)

See Figure 28 for location of offset when using specific routing for grip area only. Figure 29 is actual size top view of standard full length handle and panel. We recommend that you use the grid (Figure 29) to lay out your panel design for finger clearance when standard full length handles are used.

**NOTE:** Handle profile does not apply to Model 590, however panel weight limit does.

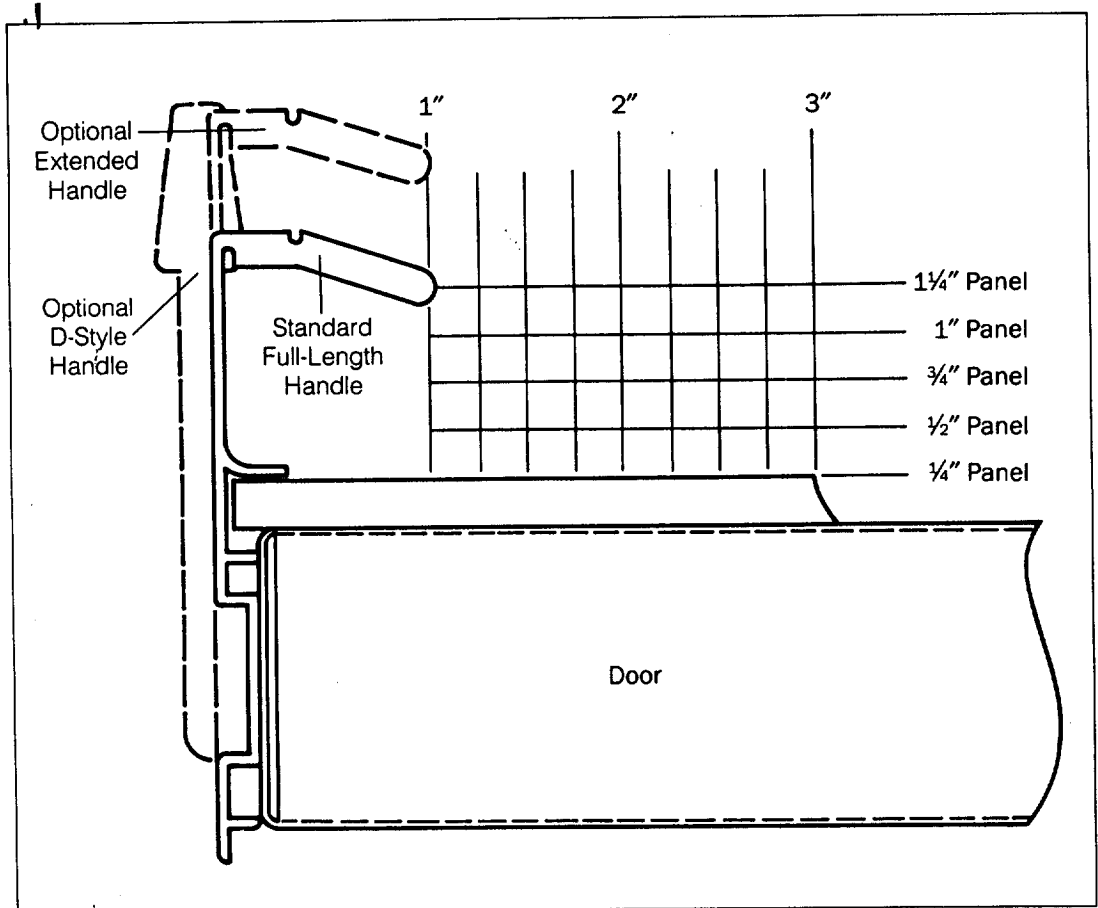
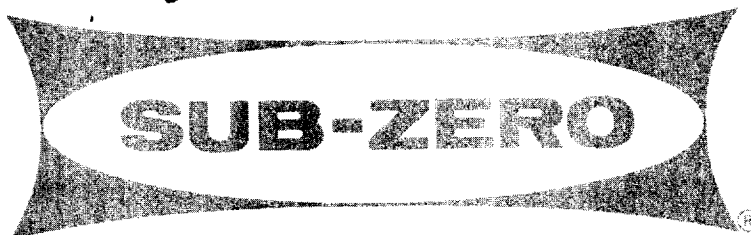

Figure 29

— Actual size topview.  
 Standard full length  
 handle.

**DUE TO OUR CONTINUOUS IMPROVEMENT PROGRAM, MODELS AND SPECIFICATIONS ARE SUBJECT TO CHANGE WITHOUT NOTICE.**



---

---

**THINK SAFETY!**

If you are storing or disposing of your old refrigerator, please do it safely. Read the enclosed safety booklet from the Association of Home Appliance Manufacturers.

**CHILD ENTRAPMENT ACCIDENTS CAN BE TRAGIC!**

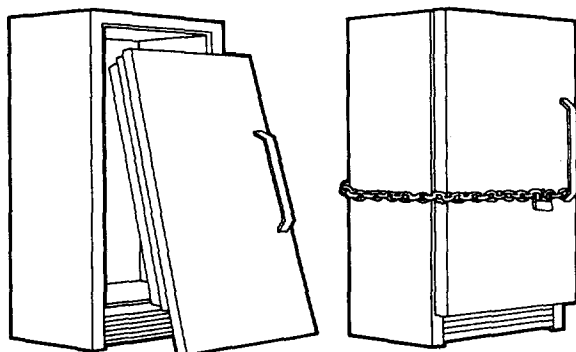

**SUB-ZERO**

**SUB-ZERO**

**SUB-ZERO**

**SUB-ZERO**

**SUB-ZERO**

**SUB-ZERO**

SUB-ZERO FREEZER CO., INC.

P.O. BOX 44130, MADISON, WI 53744-4130

(608) 271-2233