B U I L T - I N

500S *Series*

**Planning
and
Installation
Guide**



R E F R I G E R A T I O N



When Only The Best Will Do...Sub-Zero

When only the best will do for you, look to the best. Look to Sub-Zero, the industry leader in built-in home refrigeration.

Our 20 models vary in size from 18" to 48" in width, and offer storage space from 4.6 cubic feet to 30.

We offer the finest warranty in the business in our 12-year Sub-Zero Protection Plan. And if service is necessary, there is a network of thousands of factory-trained technicians across the United States and Canada.

Each Sub-Zero is protected with a full two-year (parts and labor) warranty on the entire product from the date of installation. The unmatched Sub-Zero protection also includes a full five-year (parts and labor) warranty and limited six-through-twelfth-year (parts) warranty on the sealed system (compressors, condenser, evaporator, drier and all connecting tubing). Warranty does not include installation. See complete warranty for non-residential use and other exceptions.

Sub-Zero features and options are listed on page 7. This Planning and Installation Guide is intended to offer you a profile of our units, and what it takes to plan for and install a Sub-Zero. If you would like our colorful Full Line sales brochure, or if you have installation questions that are not answered in this Guide, please give us a call at (800) 222-7820.

We would also like to hear from you if you have any comments on how we can make this Guide a better tool for you. Direct your comments to the Marketing Services Manager, Sub-Zero Freezer Company, P.O. Box 44130, Madison, WI 53744-4130.

Table of Contents

Full-Size Models	4-7
Undercounter Models	8-9
Planning Information	10-11
Integrating Cabinetry	12-13
Installation Instructions	13-15
Panel Installation	16-19
Installation Check List	19

IMPORTANT NOTE:

As you follow these instructions, you will notice warning and caution symbols. This blocked information is important for the safe and efficient installation of this Sub-Zero.

There are two types of potential hazards that may occur during this installation.

▲ WARNING

states a hazard may cause serious injury or death if precautions are not followed.

▲ CAUTION

signals a situation where minor injury or product damage may occur if you do not follow instructions.

Another footnote we would like to identify is:

IMPORTANT NOTE:

This highlights information that is especially relevant to a problem-free installation.



Full-Size Models

Sub-Zero offers the most complete line of built-in refrigeration options for your design alternatives. Our 10 full-size models enable you to meet your specific needs and preferences.

All Refrigerator

Model 501R

Dimensions

Overall Size:

H 73" W 36" D 24"

Minimum Height Required:

72³/₄"

Door Swing Clearance: 36¹/₁₆"

Door Panel:

H 58¹⁵/₁₆" x W 34¹/₈"

Energy Usage

668 kwh/\$58/Annually*

Storage Information

Refrigerator:

20 cu.ft. of Storage

4 Adjustable Glass Shelves

1 Stationary Glass Shelf

4 Crispers

1 Adjustable Utility Basket

3 Adjustable Door Shelves

1 Adjustable Dairy

Compartment

2 Egg Trays

Crated Weight

391 pounds

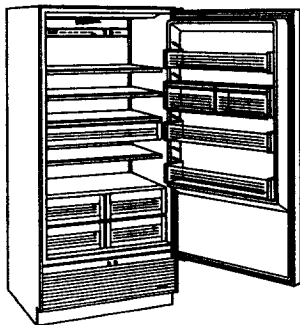

Model 501R

All Freezer

Model 501F

Dimensions

Overall Size:

H 73" W 36" D 24"

Minimum Height Required:

72³/₄"

Door Swing Clearance: 36¹/₁₆"

Door Panel:

H 58¹⁵/₁₆" x W 34¹/₈"

Energy Usage

876 kwh/\$76/Annually*

Storage Information

Freezer:

19.2 cu.ft. of Storage

3 Adjustable Wire Shelves

1 Stationary Glass Shelf

3 Drawers

5 Adjustable Door Shelves

Ice Maker with Storage Drawer

Crated Weight

378 pounds

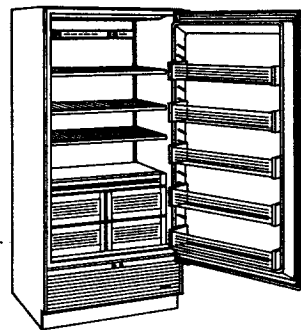

Model 501F

Due to our continuous improvement program, models and specifications are subject to change without notice.

Refrigerator/Freezer

Model 511

Dimensions

Overall Size:

H 84" W 30" D 24"

Minimum Height Required:

82⁷/₈"

Door Swing Clearance: 30¹/₈"

Door Panels:

H 48¹/₁₆" x W 28¹/₈",

H 18³/₈" x W 28¹/₈"

Energy Usage

709 kwh/\$61/Annually*

Storage Information

Refrigerator:

12.7 cu.ft. of Storage

3 Adjustable Glass Shelves

1 Stationary Glass Shelf

2 Crispers

1 Adjustable Utility Basket

2 Adjustable Door Shelves

1 Adjustable Dairy

Compartment

2 Egg Trays

Freezer:

5.2 cu.ft. of Storage

Two Tier Pull-out Drawer

Ice Maker

Crated Weight

430 pounds

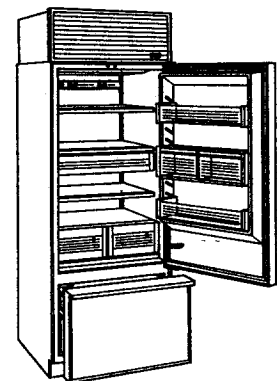

Model 511

** Annual energy costs are based on 8.67 cents per kilowatt hour.*

Refrigerator/Freezer

Model 550 Model 550SS

Dimensions

Overall Size:

H 84" W 36" D 24"

Minimum Height Required:

82⁷/₈"

Door Swing Clearance: 36¹/₁₆"

Door Panels:

H 48¹/₁₆" x W 34¹/₈"

H 18³/₈" x W 34¹/₈"

Energy Usage

789 kwh/\$68/Annually*

Storage Information

Refrigerator:

15.7 cu.ft. of Storage

3 Adjustable Glass Shelves

1 Stationary Glass Shelf

2 Crispers

1 Adjustable Utility Basket

2 Adjustable Door Shelves

1 Adjustable Dairy

Compartment

2 Egg Trays

Freezer:

6.4 cu.ft. of Storage

Two Tier Pull-out Drawer

Ice Maker

Crated Weight

Model 550: 482 pounds

Model 550SS: 515 pounds

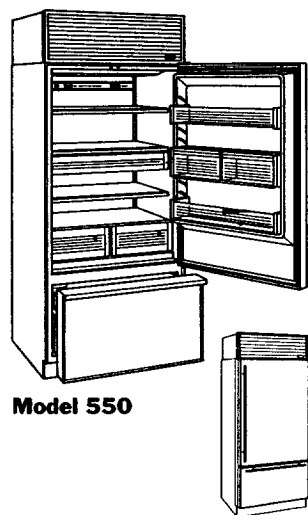

Model 550

Model 550SS

Refrigerator/Freezer

Model 561

Dimensions

Overall Size:

H 84" W 36" D 24"

Minimum Height Required:

82⁷/₈"

Door Swing Clearance: 20³/₄"

Door Panels:

H 67¹¹/₁₆" x W 14⁵/₈"

H 67¹¹/₁₆" x W 19¹/₈"

Energy Usage

811 kwh/\$70/Annually*

Storage Information

Refrigerator:

12.5 cu.ft. of Storage

4 Adjustable Glass Shelves

1 Stationary Glass Shelf

2 Crispers

1 Adjustable Utility Basket

3 Adjustable Door Shelves

1 Adjustable Dairy

Compartment

1 Egg Tray

Freezer:

8.9 cu.ft. of Storage

2 Adjustable Wire Shelves

1 Stationary Metal Shelf

4 Drawers

5 Adjustable Door Shelves

Ice Maker with Storage Drawer

Crated Weight

500 pounds

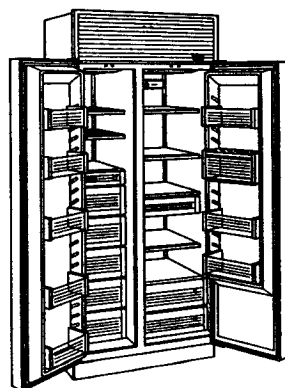

Model 561

Refrigerator/Freezer

Model 542

Dimensions

Overall Size:

H 84" W 42" D 24"

Minimum Height Required:

82⁷/₈"

Door Swing Clearance: 25⁹/₁₆"

Door Panels:

H 67¹¹/₁₆" x W 15⁵/₈"

H 67¹¹/₁₆" x W 24"

Energy Usage

858 kwh/\$74/Annually*

Storage Information

Refrigerator:

16 cu.ft. of Storage

4 Adjustable Glass Shelves

1 Stationary Glass Shelf

2 Crispers

1 Adjustable Utility Basket

3 Adjustable Door Shelves

1 Adjustable Dairy

Compartment

2 Egg Trays

Freezer:

9.2 cu.ft. of Storage

3 Adjustable Wire Shelves

1 Stationary Metal Shelf

4 Drawers

5 Adjustable Door Shelves

Ice Maker with Storage Drawer

Crated Weight

541 pounds

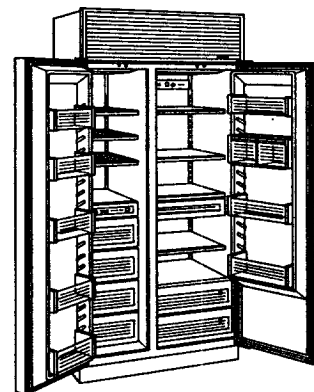

Model 542

Full-Size Models

Crated Weight

Model 532: 582 pounds

Model 532SS: 630 pounds

Refrigerator/Freezer

Model 532 Model 532SS

Dimensions

Overall Size:

H 84" W 48" D 24"

Minimum Height Required:

82⁷/₈"

Door Swing Clearance: 29¹/₄"

Door Panels:

H 67¹¹/₁₆" x W 17¹⁵/₁₆"

H 67¹¹/₁₆" x W 27¹¹/₁₆"

Energy Usage

929 kwh/\$81/Annually*

Storage Information

Refrigerator:

18.8 cu.ft. of Storage

4 Adjustable Glass Shelves

1 Stationary Glass Shelf

4 Crispers

1 Adjustable Utility Basket

3 Adjustable Door Shelves

1 Adjustable Dairy

Compartment

2 Egg Trays

Freezer:

11.2 cu.ft. of Storage

2 Adjustable Wire Shelves

1 Stationary Metal Shelf

4 Drawers

5 Adjustable Door Shelves

Ice Maker with Storage Drawer

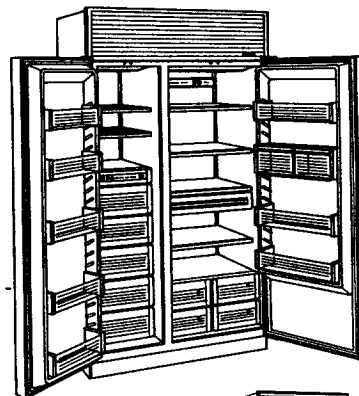

Model 532



Model 532SS

Storage Information

Refrigerator:

18.2 cu.ft. of Storage

4 Adjustable Glass Shelves

1 Stationary Glass Shelf

4 Crispers

1 Adjustable Utility Basket

3 Adjustable Door Shelves

1 Adjustable Dairy

Compartment

2 Egg Trays

Freezer:

11.2 cu.ft. of Storage

3 Adjustable Wire Shelves

2 Removable Plastic Shelves

3 Drawers

5 Adjustable Door Shelves

Ice Maker with Storage Bin

Crated Weight

610 pounds

Refrigerator/Freezer with Ice and Water Dispenser

Model 590

Dimensions

Overall Size:

H 84" W 48" D 24"

Minimum Height Required:

82⁷/₈"

Door Swing Clearance: 29¹/₄"

Door Panels:

H 67¹¹/₁₆" x W 15¹/₈"

H 67¹¹/₁₆" x W 20⁹/₁₆"

Grille Panel:

H 9³/₁₆" x W 46³/₁₆"

Energy Usage

1111 kwh/\$96/Annually*

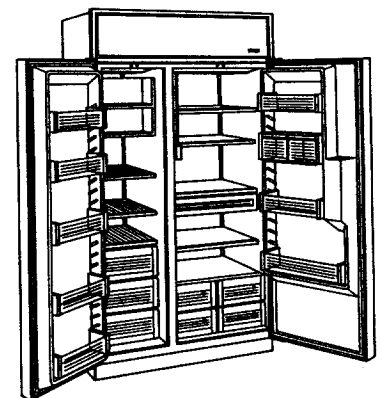

Model 590

* Annual energy costs are based on 8.67 cents per kilowatt hour.

Features

Features and Options

Sub-Zero's integrated design, beauty and quality is evident in all of these features that are standard on Sub-Zero's ten 500 Series full-size units.

- **Built-in Design.** All Sub-Zeros are only 24" deep. They accept decorative door and side panels (50 lb. weight limit per door panel), to match virtually any cabinetry. The perimeter thickness cannot exceed 1/4". See pages 12 and 13 for details.
- **Colored Panels.** Optional steel door and side panels are available from our factory in three colors: almond, stainless steel and white. (Model 590 offers your choice of seven complementary colored glasswells and ten optional color handle inset trim panels at no cost. The standard colored glasswell is pewter gray and handle inset trim panel is pin-stripped pewter gray.) The Models 550SS and 532SS come with stainless steel panels.
- **Satin Trim.** Door screws are hidden on these units so you have a clean look.

- **Door Handles.** All units have our low-profile door handles as a standard feature. A D-style handle is an option on Models 501R, 501F, 511 and 550. An extended full-length handle is also offered as an option on all models. Refer to Figure A, Page 10A for panel sizing information. With the Models 550SS and 532SS, the standard handles are one-inch in diameter stainless steel.

- **Grilles.** Sub-Zero's 11" louvered grille is standard on all models with the exception of the Model 590. An optional easy-access (EA) panel grille that accepts decorative panel inserts is also available. In either instance, you can order them in one inch increments from 10" to 15". Model 590 has the EA panel grille standard. The Models 550SS and 532SS have an attractive, heavy-duty stainless steel grille to complement the overall professional look of the units.

- **Toe Plate.** Adjustable, solid toe plate meets the standards of the American Institute of Architects. Inset area a 4" high by 3" deep. All units have a paintable black toe plate except for the Models 550SS and 532SS feature a stainless steel toe plate.

- **Adjustable Shelves.** Cantilever glass shelves in the refrigerator, wire shelves in the freezer and all of the door shelves are adjustable.

- **Crispers.** Each crisper has its own humidity control and moves easily on our roller track system.

- **Ice Maker.** Each Sub-Zero freezer offers an automatic ice maker providing crescent-shaped ice.

- **Utility Basket.** Smaller items are stored in the refrigerator's adjustable utility basket.

- **Dairy & Egg Modules.** Two dairy compartments have full magnetic seals to maintain freshness. A portable egg tray offers handy storage and is removable.

- **Diffused Lighting.** Sub-Zero's overhead lighting floods both the refrigerator and freezer compartments with even light.

- **Dual Compressors.** Two compressors in all our combination refrigerator/freezer units deliver precise, and independent temperature in the section it controls.

- **Automatic Defrost.** Sub-Zero refrigerator and freezer units have an automatic defrost system.

- **Front Venting.** All Sub-Zero units are front vented so you can plan for a truly built-in refrigerator.

- **Door Swing.** You can choose left or right door swing on our single door units as well as our over-and-under models. This option must be ordered when requesting the unit. You cannot reverse the door in the field.

- **Magnetic Door Gasket.** Our positive sealing gasket ensures a tight closing door.

- **Roller Base.** Patented roller base assembly allows for easy installation.

- **Door Stop Kit.** For installations where the door swing must be limited to 90 degrees, an optional Door Stop Kit is available. Normal door swing is 130 degrees with the exception of the 511 and 550(SS). The normal door swing on these models is 120 degrees.

Undercounter Models

Sub-Zero undercounter refrigerators, freezers, combination units and ice maker all accept decorative door panels (maximum 20 pound limit) to fit any decor and can be built in to fit flush with virtually any base cabinet style.

Equally important, they are all backed by the best warranty in the business, the 12-year Sub-Zero Protection Plan. See page 3 for details.

All undercounter models are self-venting, feature foamed insulation, have durable, easy-to-clean ABS interior surfaces and offer interchangeable door swings. (Kit required, except for Model 245.)

These models can be built-in or installed as free standing.

** Annual energy costs are based on 8.67 cents per kilowatt hour.*

Refrigerator/Freezer with Auto Defrost

Model 245

Dimensions

Overall Size:

H 34" W 23⁷/₈" D 24"

Door Swing Clearance: 25¹³/₁₆"

Door Panel:

H 28¹/₈" x W 23¹/₂"

Energy Usage

463 kwh/\$40/Annually*

Storage Information

Refrigerator:

3 cu.ft. of Storage

2 Stationary Shelves

1 Door Shelf

Freezer:

1.9 cu.ft. of Storage

1 Shelf

1 Door Shelf

Ice Maker with Container

Crated Weight

139 pounds

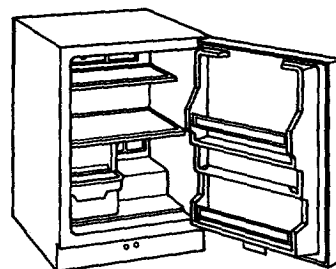

Model 245

Refrigerator/Freezer

Model 249R

Dimensions

Overall Size:

H 33¹³/₁₆" W 23⁷/₈" D 24"

Door Swing Clearance: 25³/₈"

Door Panel:

H 30" x W 23⁵/₈"

Energy Usage

368 kwh/\$32/Annually*

Storage Information

Refrigerator:

4.4 cu.ft. of Storage

2 Removable Shelves

1 Stationary Shelf

3 Door Shelves

Manual Defrost

Freezer:

.7 cu.ft. of Storage

1 Shelf

Manual Defrost

Crated Weight

120 pounds

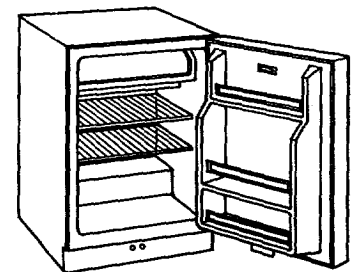

Model 249R

**All Refrigerator
with Auto Defrost**

Model 249RP

Dimensions

Overall Size:

H 33¹³/₁₆" W 23⁷/₈" D 24"

Door Swing Clearance: 25³/₈"

Door Panel:

H 30" x W 23⁵/₈"

Energy Usage

429 kwh/\$37/Annually*

Storage Information

Refrigerator:

4.9 cu.ft. of Storage

2 Removable Shelves

1 Stationary Shelf

3 Door Shelves

Crated Weight

117 pounds

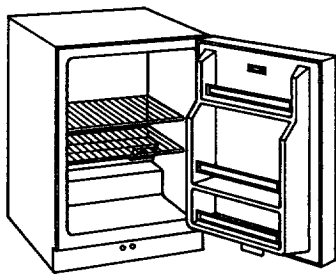

Model 249RP

**All Freezer
with Auto Defrost**

Model 249FF

Dimensions

Overall Size:

H 33¹³/₁₆" W 23⁷/₈" D 24"

Door Swing Clearance: 25³/₈"

Door Panel:

H 30" x W 23⁵/₈"

Energy Usage

504 kwh/\$44/Annually*

Storage Information

Freezer:

4.6 cu.ft. of Storage

2 Removable Shelves

1 Stationary Shelf

Ice Maker Optional

Crated Weight

135 pounds

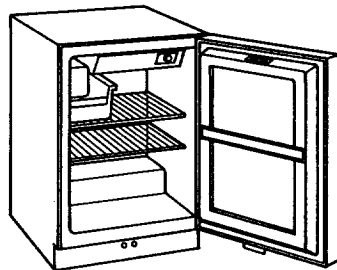

Model 249FF

Ice Maker

Model 506

Dimensions

Overall Size:

H 34¹³/₃₂" W 17⁷/₈" D 23⁷/₈"

Door Swing Clearance:

11³/₄"

Door Panels:

H 13³/₁₆" x W 17"

H 11¹⁵/₁₆" x W 17"

Storage Information

35 lbs. of Ice

3/4" Clear Ice Cubes

Hopper Door

*Drain or optional pump is
necessary.*

Crated Weight

110 pounds

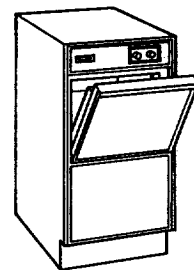

Model 506

Planning Information

Area Requirements

Before moving ahead with any planning you should be aware of the basic requirements for the installation of a built-in Sub-Zero. The drawings in Figures 1 and 2 illustrate the finished rough in dimensions, electrical and plumbing locations and minimum door clearance for all units.

MODEL	Finished Rough Opening Dimensions		Minimum Door Clearance Required at 90°	Minimum Height Required (with levelers in)	Recommended Electrical Outlet Location		Water Supply Location
	A	B			C	D	
501R	35 1/2"	72 3/4"	36 1/16"	72 3/4"	3"	6"	-
501F	35 1/2"	72 3/4"	36 1/16"	72 3/4"	3"	6"	-
511	29 1/2"	83 3/4"	30 1/8"	82 7/8"	75 1/2"	-	-
550(SS)	35 1/2"	83 3/4"	36 1/16"	82 7/8"	75 1/2"	-	-
561	35 1/2"	83 3/4"	20 3/4"	82 7/8"	75 1/2"	-	-
542	41 1/2"	83 3/4"	25 9/16"	82 7/8"	75 1/2"	-	-
532(SS)	47 1/2"	83 3/4"	29 1/4"	82 7/8"	75 1/2"	-	-
590	47 1/2"	83 3/4"	29 1/4"	82 7/8"	75 1/2"	-	-
245	24"	34 1/2"	25 13/16"	34 1/4"	1"	2"	12"
249R	24"	34 1/2"	25 3/8"	34 1/4"	10 1/2"	8 1/2"	-
249RP	24"	34 1/2"	25 3/8"	34 1/4"	10 1/2"	8 1/2"	-
249FF	24"	34 1/2"	25 3/8"	34 1/4"	10 1/2"	2 1/2"	18"
506	18"	34 1/2"	11 3/4"	34 1/4"	2 1/2"	2 1/2"	11"

IMPORTANT NOTE: When using frameless cabinets, you must add space to the finished rough opening to allow for side mainframe overlap to ensure cabinet and Sub-Zero doors open properly. This space will fluctuate depending on the installation and overall visual appearance you are trying to achieve.

IMPORTANT NOTE: When installing cabinets with six inch bases, add two inches to the minimum height detailed above, if you want to make the base of the Sub-Zero even with the cabinets.

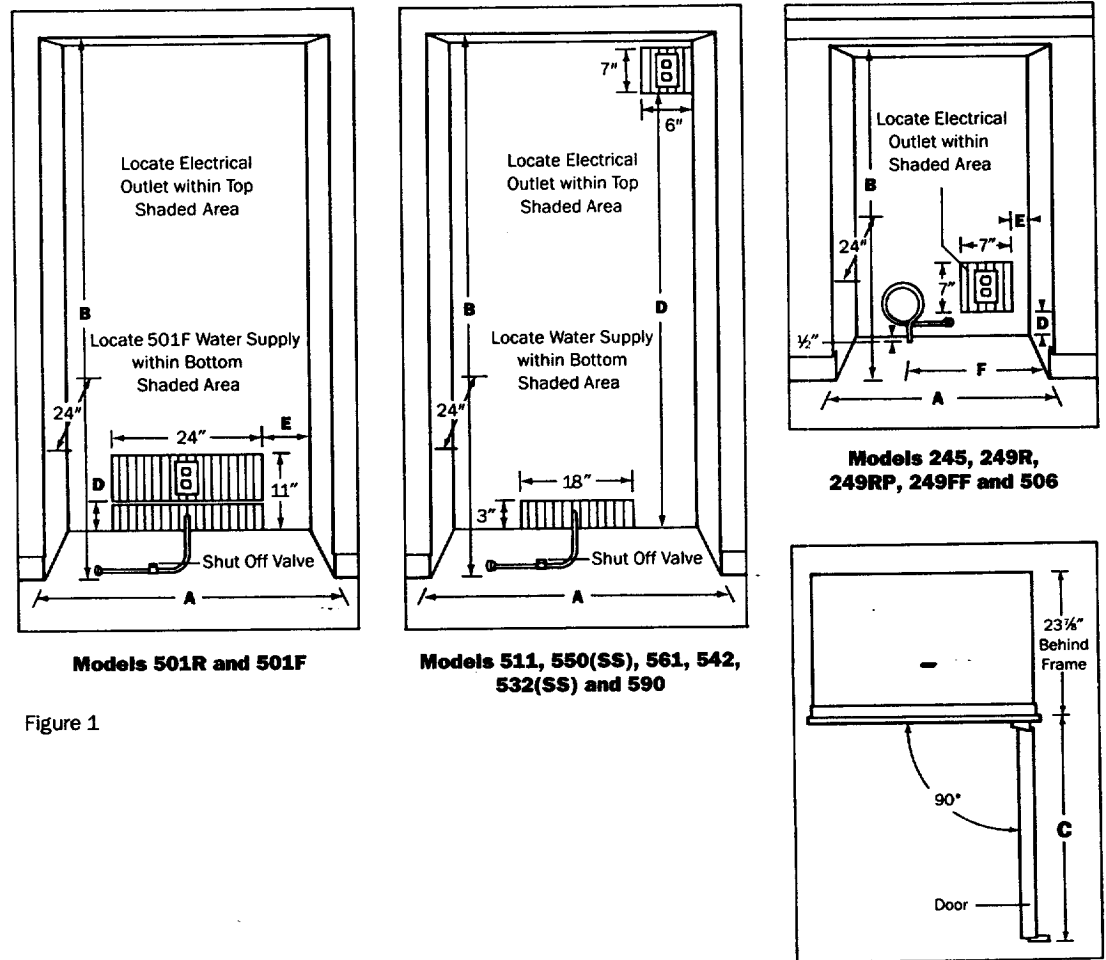
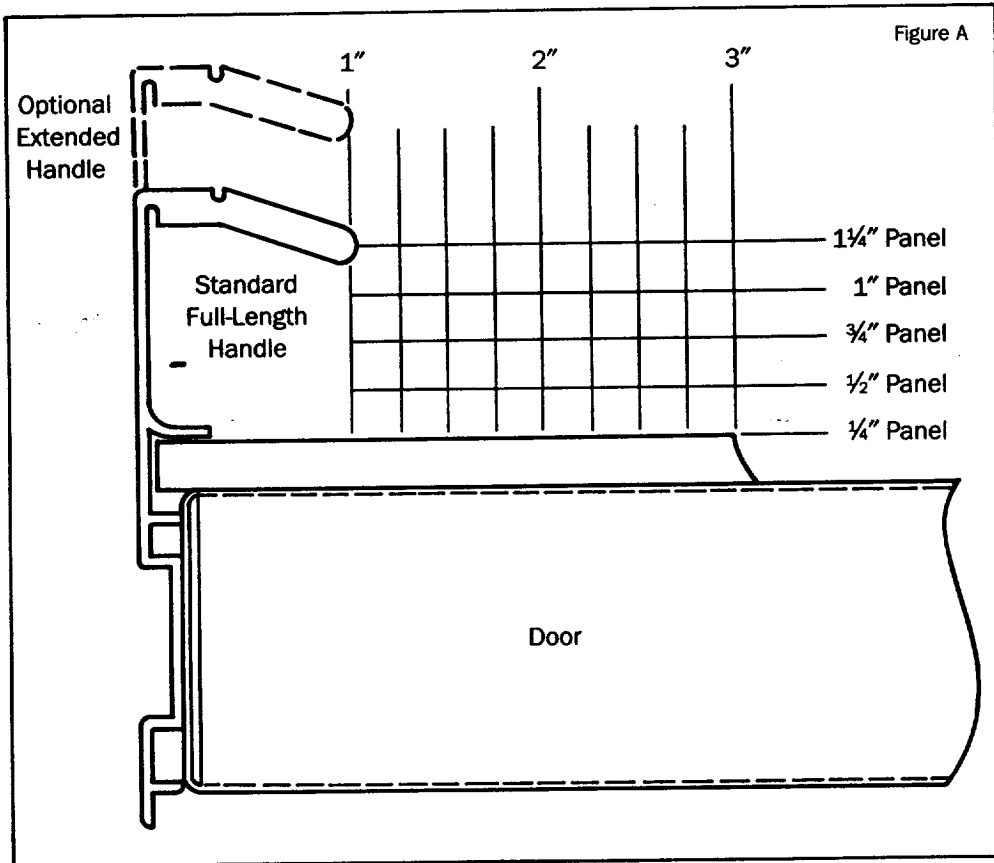

Figure 1

Figure 2



These actual size drawings offer you the opportunity to better understand unique situations you may face in some of your installations. The page can easily be removed and photocopied or used for your own tracings.

Figure A shows the clearance you would have for raised panels using the standard full-length handle or the optional extended full-length handle illustrated in the dash line.

Figure B below illustrates a typical 501 pair installation where a filler strip is being used and the doors open at the standard 130 degrees. Depending on the configuration and panels, this filler strip will vary.

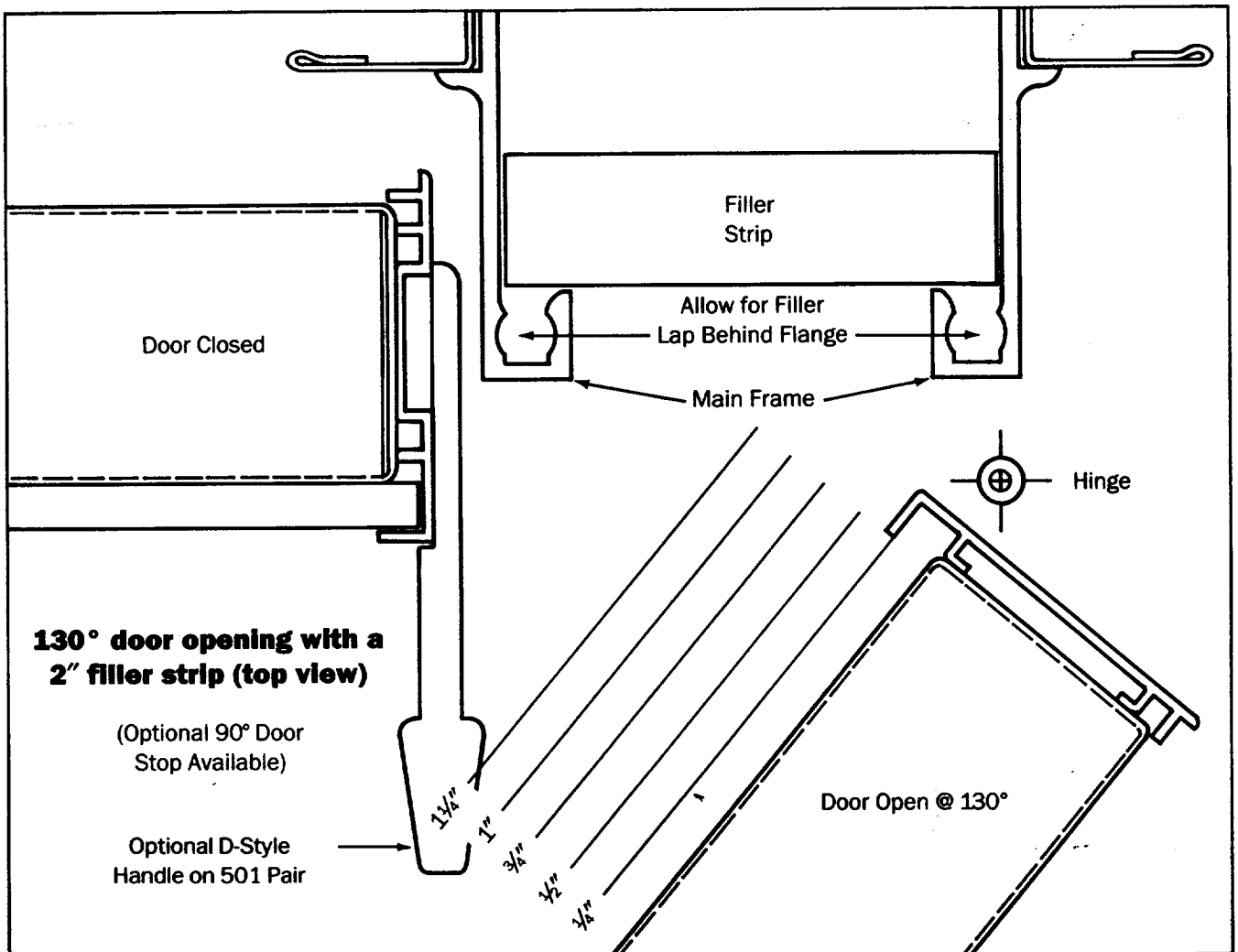

Figure B

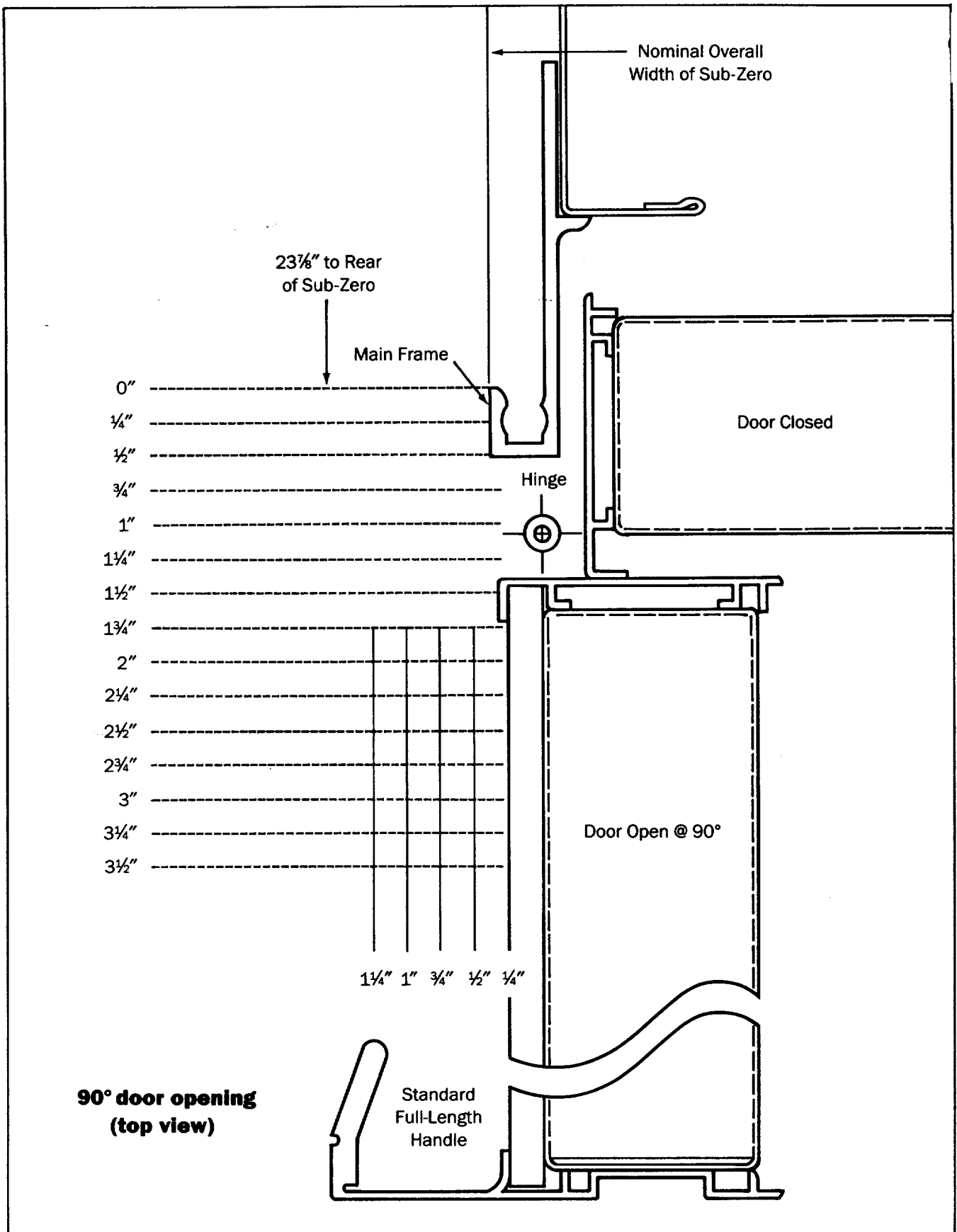

Figure C

This overall view of a unit, its door and the relationship to a counter, a built-in wall appliance or corner shows how a filler strip may prevent damage to raised panels.

- Panels must be 1/4" thick around the perimeter and routed to allow for 1/4" edge, except for Model 245, which requires 3/8".

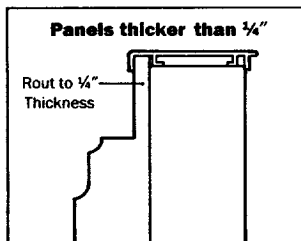
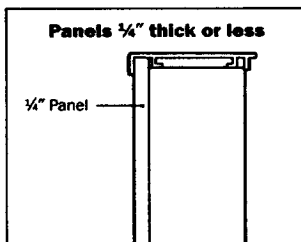

Figure 6

- Thicker raised panels may require special consideration with door swings and clearance. See center pages 10A and 10B.
- You may consider using an optional extended handle. See Figure A, Page 10A.
- Panels must not exceed 50 pounds for each door panel on the full-size units and 20 pounds on the undercounter units.

Grille Panels

The Sub-Zero 11" louvered grille is standard on all units with the exception of the Model 590. An easy-access (EA) panel grille is available as an option for all models and easily accepts decorative panels. The Model 590 has this 11" EA panel grille as a standard feature. The Models 550SS and 532SS come standard with an 11" heavy duty stainless steel grille. A 15" heavy duty grille is also available for these two models.

As with the standard grille, the EA panel grille can be ordered in one inch increments from 10" to 15".

The following sizes should be used when ordering decorative inserts for the EA panel grille. There is a 15 pound weight limit on these inserts.

Grille Size	Panel Size
10 x 30	8 ³ / ₁₆ " x 28 ³ / ₁₆ "
11 x 30	9 ³ / ₁₆ " x 28 ³ / ₁₆ "
12 x 30	10 ³ / ₁₆ " x 28 ³ / ₁₆ "
13 x 30	11 ³ / ₁₆ " x 28 ³ / ₁₆ "
14 x 30	12 ³ / ₁₆ " x 28 ³ / ₁₆ "
15 x 30	13 ³ / ₁₆ " x 28 ³ / ₁₆ "
10 x 36	8 ³ / ₁₆ " x 34 ³ / ₁₆ "
11 x 36	9 ³ / ₁₆ " x 34 ³ / ₁₆ "
12 x 36	10 ³ / ₁₆ " x 34 ³ / ₁₆ "
13 x 36	11 ³ / ₁₆ " x 34 ³ / ₁₆ "
14 x 36	12 ³ / ₁₆ " x 34 ³ / ₁₆ "
15 x 36	13 ³ / ₁₆ " x 34 ³ / ₁₆ "
10 x 42	8 ³ / ₁₆ " x 40 ³ / ₁₆ "
11 x 42	9 ³ / ₁₆ " x 40 ³ / ₁₆ "
12 x 42	10 ³ / ₁₆ " x 40 ³ / ₁₆ "
13 x 42	11 ³ / ₁₆ " x 40 ³ / ₁₆ "
14 x 42	12 ³ / ₁₆ " x 40 ³ / ₁₆ "
15 x 42	13 ³ / ₁₆ " x 40 ³ / ₁₆ "
10 x 48	8 ³ / ₁₆ " x 46 ³ / ₁₆ "
11 x 48	9 ³ / ₁₆ " x 46 ³ / ₁₆ "
12 x 48	10 ³ / ₁₆ " x 46 ³ / ₁₆ "
13 x 48	11 ³ / ₁₆ " x 46 ³ / ₁₆ "
14 x 48	12 ³ / ₁₆ " x 46 ³ / ₁₆ "
15 x 48	13 ³ / ₁₆ " x 46 ³ / ₁₆ "

Any other custom grille must meet required airflow requirements and you should contact Sub-Zero before installing one.

Side Panels

If side panels are to be used refer to pages 17 and 18, the side panel installation section of the guide, for specifics regarding sizing.

Moving Unit

The installation of a Sub-Zero is an easy task if you have done the necessary preparation. Before bringing the unit into a house, it should be uncrated outside. Remove the box and wood base and discard this material. Do not discard wood block and hardware to be used for blocking your unit.

In addition retract front leveler legs to ensure easier movement of the unit for installation.

⚠ WARNING

To reduce the possibility of the unit tipping forward, you must reposition the front levelers to make contact with the floor. You will have to extend these legs when the unit is finally positioned.

You should remove the grille for easier transportation through doorways and later access to the power cord.

Installation Instructions

Models 511, 550, 561, 542 and 532

Remove center grille screw and cut the red nylon shipping strap. **IMPORTANT NOTE:** This screw must be removed before grille is tilted or damage can occur.

Tilt the grille forward and release the spring(s) from behind grille. See Figure 7.

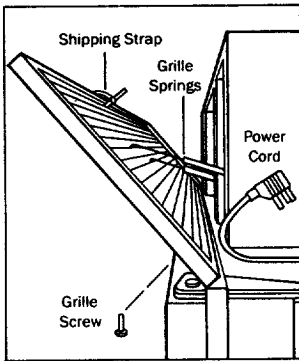

Figure 7

Models 501R and 501F

To remove the 501 grille, remove two (black) screws located in the lowest louver in the grille. Tilt the bottom of the grille out and away, it will release from the top of the grille. There is no grille spring on the 501 units. See Figure 8.

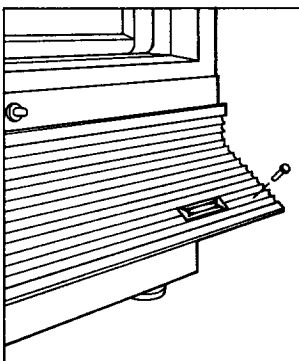

Figure 8

Model 590

To remove Model 590 grille assembly, the inner grille panels assembly must first be removed. Lift up (1), then pull out at the bottom (2), then pull top section down and out of the top key slot (3) as in Figure 9. Next, remove the five mounting screws that hold the outer grille panel assembly to the top compartment. See Figure 10.

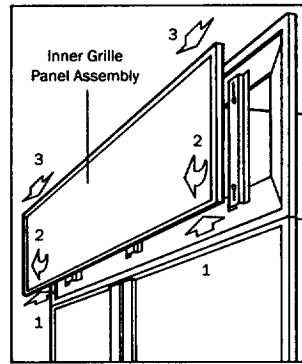

Figure 9

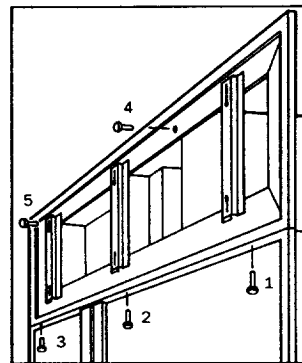

Figure 10

Blocking

⚠ WARNING

To help prevent the unit from tipping forward and provide a stable installation, the unit must be secured in place with a solid soffit or wood block.

If there is a solid soffit above the unit with clearance between the unit and the soffit of one inch or less, as illustrated in Figure 11, you do not need to block the unit. If this is not the case, **you must block the unit.**

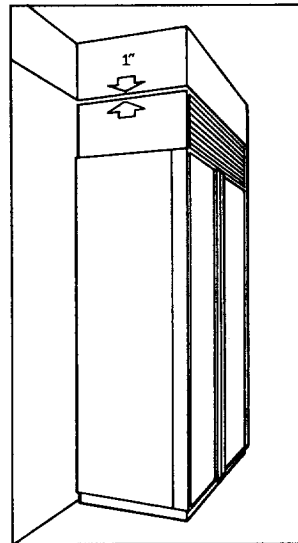

Figure 11

To block the unit, using the wood block and hardware provided, follow these steps:

- Locate and mark two wall studs against the wall where the refrigerator is to be located.

- Locate the proper height to clear the unit. The space along the top of the Sub-Zero between the unit and the bottom of the wood block **must not be greater** than 1/4 inch. See Figure 12.

- Position the wood block over the unit and secure it using the screws and "L" brackets provided. Make sure screws extend a minimum of 7/8 of an inch into each of the two wall studs. The wood block must extend a minimum of three inches over the unit. See Figure 12.

- Using the front and rear levelers, the unit must be raised until it contacts the wood block. See Figure 15.

⚠ WARNING

To reduce the possibility of cabinet tipping forward, front levelers must be in contact with floor. See Figure 15.

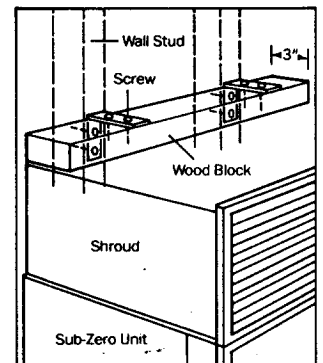

Figure 12

Installing

⚠ WARNING

Shut off the power to the wall outlet.

⚠ CAUTION

Protect any finished flooring before moving the unit in place. All full size Sub-Zero models are equipped with rollers, so you can easily move the unit into place.

If for any reason, the unit has been laid on its back or side, you must allow the unit to stand upright for a minimum of 24 hours before connecting power.

⚠ CAUTION

Plug the unit into 15 amp grounded outlet and roll the unit into desired position. Now you have to connect the ice maker water line.

Cut the red nylon shipping strap holding the garden hose fitting, compression nut and sleeve to the toe plate bracket. Connect the 1/4" compression nut and sleeve on the copper tubing to the hose fitting before attaching the fitting to the solenoid valve. Purge the water line before the final hookup to the valve. See Figure 13 and for Model 590 see Figure 14.

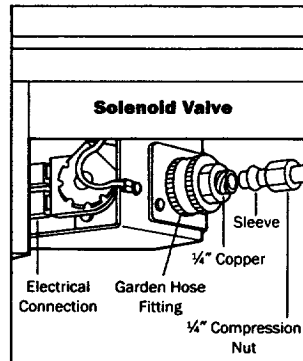

Figure 13

Turn on water supply, check all fittings for leaks and make certain the electrical harness is attached to the solenoid valve. **IMPORTANT NOTE:** The ice maker will not immediately fill with water when supplied to the valve. Allow 24 hours for proper ice production.

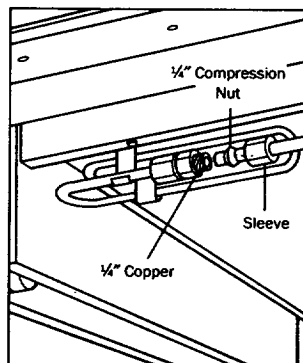

Figure 14

Leveling

With the unit positioned properly you should level the unit by turning the front leveling legs counterclockwise to raise or clockwise to lower. The rear levelers (rollers) are adjusted from the front of the base by turning the 5/16" hex bolt clockwise to raise and counterclockwise to lower the cabinet. See Figure 15.

⚠ WARNING

To reduce the possibility of the cabinet tipping forward, the front levelers must be in contact with the floor.

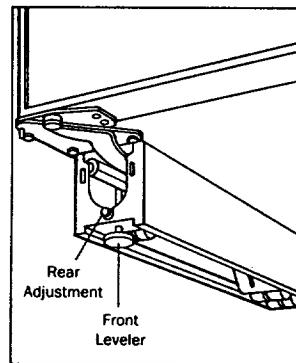

Figure 15

For a finished look to the Sub-Zero install the toe plate as illustrated in Figure 16. However, before completing this step check to ensure the drain pan is positioned properly.

⚠ CAUTION

In all cases the toe plate must be removable for servicing so any flooring or molding must allow for this removal. Refer to the label mounted on the kickplate support for height clearance.

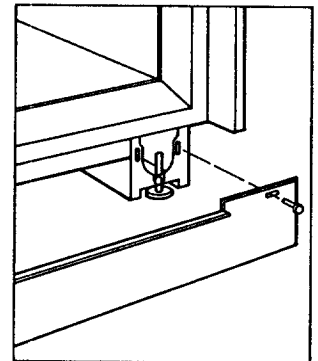

Figure 16

Panel Installation

All Sub-Zero full-size 500 Series units easily accommodate front, grille and side panels as long as you follow the points listed earlier in the Integrating Cabinetry section of this guide. (The Models 550SS and 532SS come standard with stainless steel panels and one inch diameter stainless steel handles, so panel and handle installation is not necessary.) Installation is easy following these steps.

Front Panel Installation

If a metal or other thin material is used, a filler must be inserted behind your panel to ensure a proper fit. All frames are designed to accept up to 1/4" material. Thicker pieces must be routed to the 1/4" perimeter dimension. There is a 50 lb. weight limit for each door panel.

Models 501R, 501F, 511, 550, 561, 542, and 532

Remove the door handle by first removing the trim molding as shown in Figure 17. The molding easily comes off by using a piece of tape to pull it away from the handle. This removal will expose the handle screws.

With a standard Phillips screwdriver, remove door handle on freezer and refrigerator door. The Models 511 and 550 freezer door handle is on the top of the door and removed in the same manner.

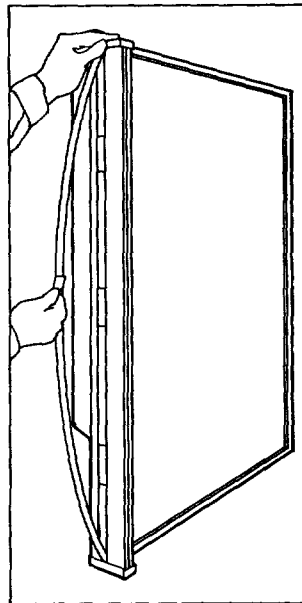

Figure 17

Slide the appropriate panel into the frame as illustrated in Figure 18.

With the panel in position, replace handle, screws and trim molding. The molding is replaced by bowing the piece gently in the middle and inserting the top and bottom edges into the handle channel first and then release the middle.

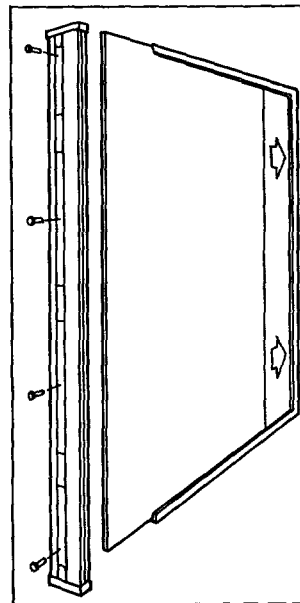

Figure 18

Model 590

Remove the trim molding in an identical manner as illustrated in Figure 17.

Once the molding is removed you can easily remove the door screws on both the refrigerator and freezer doors by using a standard Phillips screwdriver.

Remove the handle trim panels by sliding them out of the door(s) as shown in Figure 19. Complementary colored handle trim panels and glasswells are available through your product distributor.

Next, remove the ice and water glasswell by removing the mounting screw. Then slide the glasswell up and pull out as shown in Figure 19.

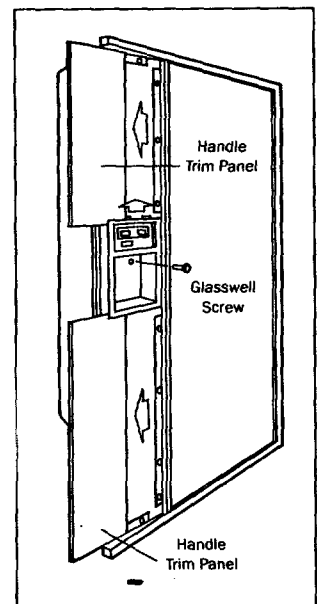

Figure 19

Remove the top and bottom trim fillers held on by the mounting screws. See Figure 20.

In similar fashion remove the screws holding the vertical trim strip. See Figure 20.

Install the door panels by sliding them into the frame on the door and reverse the earlier steps to reassemble.

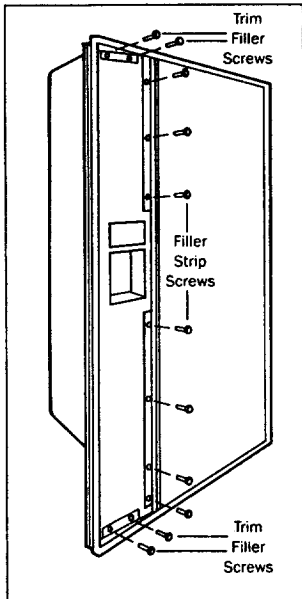

Figure 20

Side Panels

If side panels are being utilized, check with your installer for installation suggestions or consider these options.

In any of these installation alternatives, you must drill three holes equal distance apart in the vertical section of the aluminum frame and install #6 x 3/8" pan head screws to hold the panels in place. See Figure 22.

Anchor the back portion of the side panel with decorative screws or nails. Refer to Figures 23-27.

We do not recommend the use of adhesives.

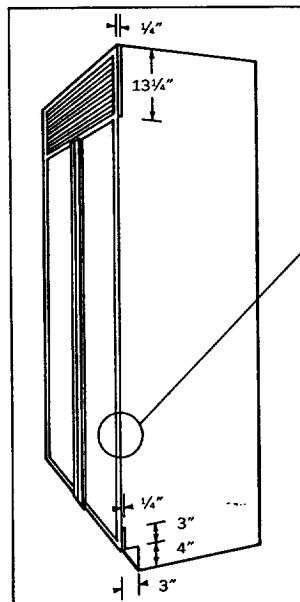

Figure 21

The dimensions supplied are for a typical wood side panel. If 1/4" panel or less is used and inserted into the return channel on the extrusion then a 24 1/4" size is necessary. The sheet must also be notched as shown in Figure 21.

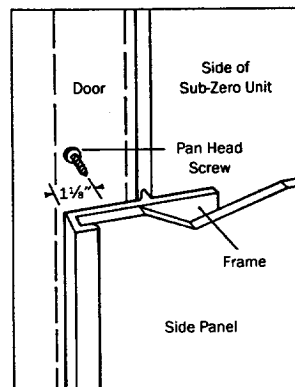

Figure 22

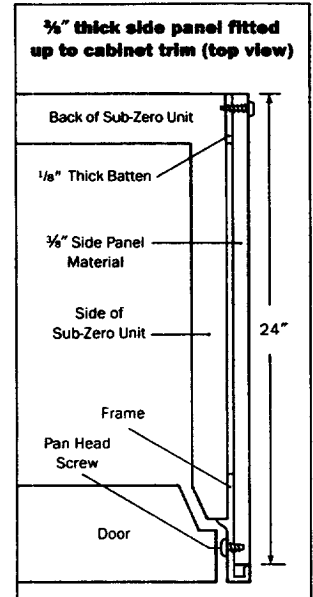

Figure 23

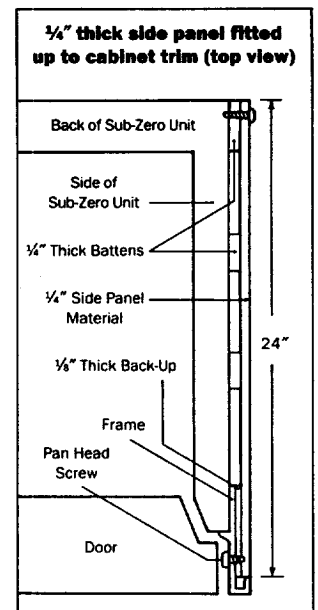

Figure 24

Panel Installation

EA Grille Panel – Model 590

Remove the inner grille panel assembly (refer to Figure 9 on page 14) and remove the top two corner screws and pull away the top frame. See Figure 28.

Lay the remaining panel assembly on a flat surface and insert the panel insert into position in the grille frame as shown in Figure 28.

Reattach the top frame and install the inner grille panel assembly back onto the unit. See Figure 9 on page 14.

Hinge Adjustment

If the doors are out of adjustment, the top or bottom hinge may be adjusted by removing and discarding the two small shipping screws. See Figure 29. The top door hinges can be adjusted left to right and in or out by loosening the three allen head screws. The bottom door hinge is equipped with two adjustment allen head screws. See Figure 30.

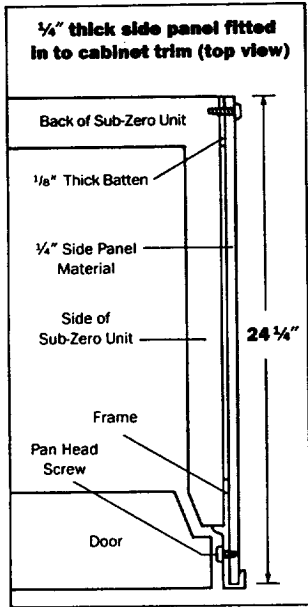

Figure 25

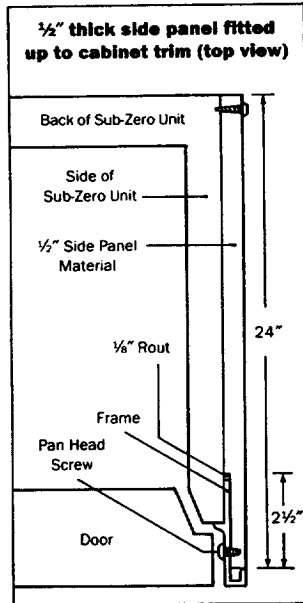

Figure 26

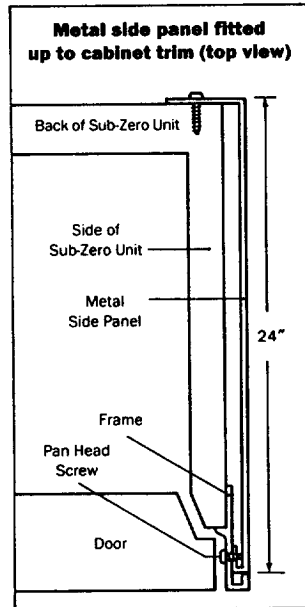

Figure 27

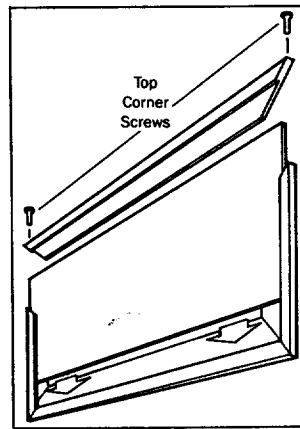

Figure 28

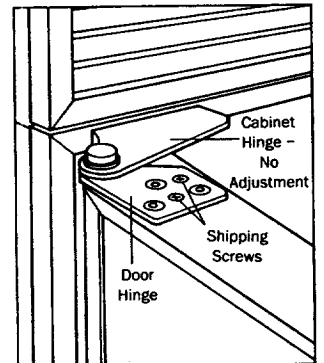

Figure 29

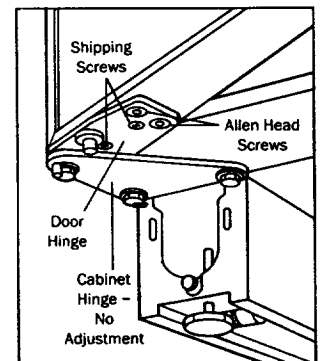

Figure 30

Installation Check List

For adjustment, use a $\frac{1}{8}$ " allen wrench to loosen screws (Models 511 and 550(SS) excluded). This allows the door to move left to right or in and out.

Once the adjustments are made be sure to tighten the allen screws tightly.

IMPORTANT NOTE:

Normal door swing is 130 degrees, except for Models 511 and 550(SS). Normal door swing on these models is 120 degrees. An optional 90 degree door stop is available.

Anchoring Product

It is recommended after going through the installation procedure that you anchor the unit to the opening. See Figures 31 and 32. Your Sub-Zero product distributor has an anchoring kit (part #4-20-090-0) for your use.

CAUTION

Do not drill through model and serial number tag.

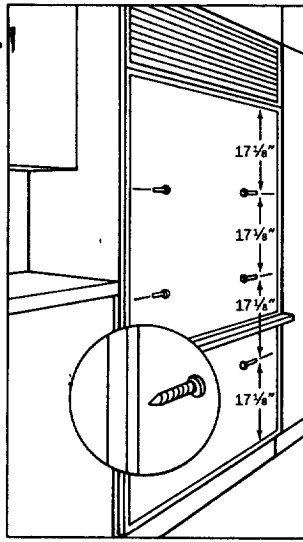

Figure 31

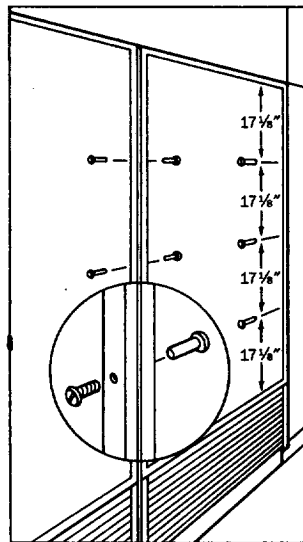

Figure 32

The importance of the installation of your Sub-Zero cannot be overemphasized. **The proper installation of your unit is the responsibility of the selling dealer or installer.** The following check list should be completed **by the installer** to insure no part of the installation has been overlooked. Any question or problems pertaining to the installation should be directed to the selling dealer.

- Is unit leveled properly on a solid floor? (Page 15)
 - Is blocking necessary? (Page 14)
 - Is drain pan installed properly?
 - Is toe plate installed? (Page 15)
 - Is grille screw back in position? (Page 14)
 - Are panels installed correctly? (Pages 16-18)
 - Are doors adjusted? (Pages 18 and 19)
 - Does the customer understand the unit's operation?
 - Is the icemaker switch turned on? (Models 561, 542, 532(SS) and 590).
- Give the customer the warranty packet.**
- Is unit operating? If not, is unit plugged in? Is refrigerator/freezer control on?
 - Is packing material removed? (Page 13)
 - Is water supply line connected to compression fitting? (Page 15)

WARNING

Disconnect power to unit before checking wiring connections.

**Product Information and Service —
1-800-222-7820**

Think Safety!

**If you are storing or disposing
of your old refrigerator, please
do it safely.**

**Child entrapment accidents
can be tragic.**

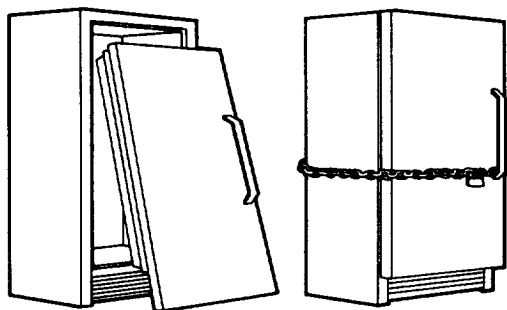

Sub-Zero Freezer Company, Inc.

Post Office Box 44130

Madison, Wisconsin 53744-4130

(800) 222-7820

500PIG 12/96 Printed in the U.S.A.