

SEARS

CRAFTSMAN[®]

MODEL NUMBER 917.252520 OWNER'S MANUAL

- **Assembly**
- **Operation**
- **Customer Responsibilities**
- **Service and Adjustments**
- **Repair Parts**

3one[®]
Convertible

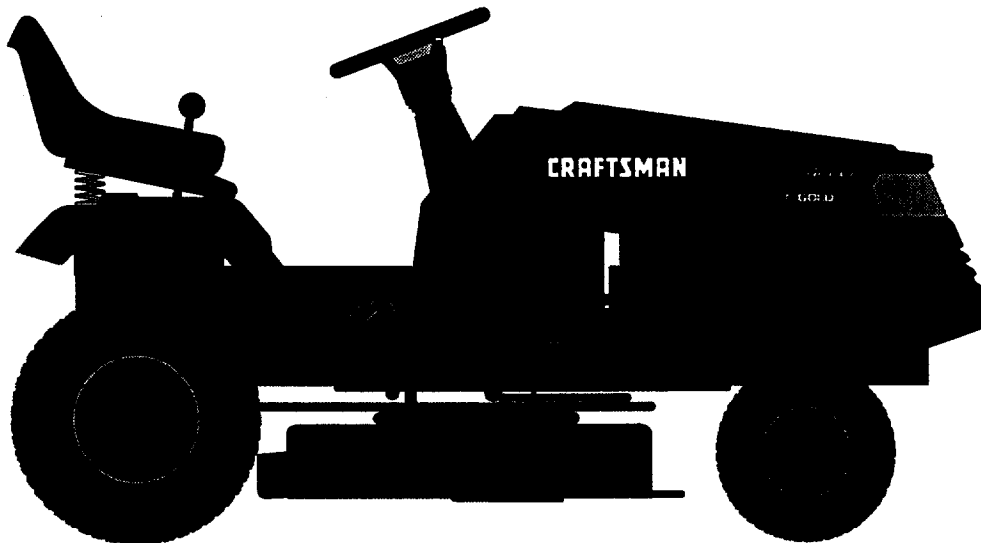

CAUTION: Read and follow all safety rules and instructions before operating this equipment.
FOR CONSUMER ASSISTANCE HOT LINE, CALL THIS TOLL FREE NUMBER: 1-800-659-5917

Sears, Roebuck and Co., Hoffman Estates, IL 60179 U.S.A.



SAFETY RULES



Safe Operation Practices for Ride-On Mowers

IMPORTANT: THIS CUTTING MACHINE IS CAPABLE OF AMPUTATING HANDS AND FEET AND THROWING OBJECTS. FAILURE TO OBSERVE THE FOLLOWING SAFETY INSTRUCTIONS COULD RESULT IN SERIOUS INJURY OR DEATH.

I. GENERAL OPERATION

- Read, understand, and follow all instructions in the manual and on the machine before starting.
- Only allow responsible adults, who are familiar with the instructions, to operate the machine.
- Clear the area of objects such as rocks, toys, wire, etc., which could be picked up and thrown by the blade.
- Be sure the area is clear of other people before mowing. Stop machine if anyone enters the area.
- Never carry passengers.
- Do not mow in reverse unless absolutely necessary. Always look down and behind before and while backing.
- Be aware of the mower discharge direction and do not point it at anyone. Do not operate the mower without either the entire grass catcher or the guard in place.
- Slow down before turning.
- Never leave a running machine unattended. Always turn off blades, set parking brake, stop engine, and remove keys before dismounting.
- Turn off blades when not mowing.
- Stop engine before removing grass catcher or unclogging chute.
- Mow only in daylight or good artificial light.
- Do not operate the machine while under the influence of alcohol or drugs.
- Watch for traffic when operating near or crossing roadways.
- Use extra care when loading or unloading the machine into a trailer or truck.

II. SLOPE OPERATION

Slopes are a major factor related to loss-of-control and tipover accidents, which can result in severe injury or death. All slopes require extra caution. If you cannot back up the slope or if you feel uneasy on it, do not mow it.

DO:

- Mow up and down slopes, not across.
- Remove obstacles such as rocks, tree limbs, etc.
- Watch for holes, ruts, or bumps. Uneven terrain could overturn the machine. *Tall grass can hide obstacles.*
- Use slow speed. Choose a low gear so that you will not have to stop or shift while on the slope.
- Follow the manufacturer's recommendations for wheel weights or counterweights to improve stability.
- Use extra care with grass catchers or other attachments. These can change the stability of the machine.
- Keep all movement on the slopes *slow* and *gradual*. Do not make sudden changes in speed or direction.
- Avoid starting or stopping on a slope. If tires lose traction, disengage the blades and proceed slowly *straight* down the slope.

DO NOT:

- *Do not* turn on slopes unless necessary, and then, turn slowly and gradually downhill, if possible.
- *Do not* mow near drop-offs, ditches, or embankments. The mower could suddenly turn over if a wheel is over the edge of a cliff or ditch, or if an edge caves in.
- *Do not* mow on wet grass. Reduced traction could cause sliding.
- *Do not* try to stabilize the machine by putting your foot on the ground.
- *Do not* use grass catcher on steep slopes.

III. CHILDREN

Tragic accidents can occur if the operator is not alert to the presence of children. Children are often attracted to the machine and the mowing activity. *Never* assume that children will remain where you last saw them.

- Keep children out of the mowing area and under the watchful care of another responsible adult.
- Be alert and turn machine off if children enter the area.
- Before and when backing, look behind and *down* for small children.
- Never carry children. They may fall off and be seriously injured or interfere with safe machine operation.
- Never allow children to operate the machine.
- Use extra care when approaching blind corners, shrubs, trees, or other objects that may obscure vision.

IV. SERVICE

- Use extra care in handling gasoline and other fuels. They are flammable and vapors are explosive.
 - Use only an approved container.
 - Never remove gas cap or add fuel with the engine running. Allow engine to cool before refueling. Do not smoke.
 - Never refuel the machine indoors.
 - Never store the machine or fuel container inside where there is an open flame, such as a water heater.
- Never run a machine inside a closed area.
- Keep nuts and bolts, especially blade attachment bolts, tight and keep equipment in good condition.
- Never tamper with safety devices. Check their proper operation regularly.
- Keep machine free of grass, leaves, or other debris build-up. Clean oil or fuel spillage. Allow machine to cool before storing.
- Stop and inspect the equipment if you strike an object. Repair, if necessary, before restarting.
- Never make adjustments or repairs with the engine running.
- Grass catcher components are subject to wear, damage, and deterioration, which could expose moving parts or allow objects to be thrown. Frequently check components and replace with manufacturer's recommended parts, when necessary.
- Mower blades are sharp and can cut. Wrap the blade(s) or wear gloves, and use extra caution when servicing them.
- Check brake operation frequently. Adjust and service as required.



Look for this symbol to point out important safety precautions. It means CAUTION!!! BECOME ALERT!!! YOUR SAFETY IS INVOLVED.



CAUTION: Always disconnect spark plug wire and place wire where it cannot contact spark plug in order to prevent accidental starting when setting up, transporting, adjusting or making repairs.

WARNING

The engine exhaust from this product contains chemicals known to the State of California to cause cancer, birth defects, or other reproductive harm.

CONGRATULATIONS on your purchase of a Sears Tractor. It has been designed, engineered and manufactured to give you the best possible dependability and performance.

Should you experience any problem you cannot easily remedy, please contact your nearest Sears Authorized Service Center/Department. We have competent, well-trained technicians and the proper tools to service or repair this tractor.

Please read and retain this manual. The instructions will enable you to assemble and maintain your unit properly. Always observe the "SAFETY RULES".

MODEL NUMBER	917.252520
SERIAL NUMBER	_____
DATE OF PURCHASE	_____
THE MODEL AND SERIAL NUMBERS WILL BE FOUND ON A PLATE UNDER THE SEAT.	
YOU SHOULD RECORD BOTH SERIAL NUMBER AND DATE OF PURCHASE AND KEEP IN A SAFE PLACE FOR FUTURE REFERENCE.	

MAINTENANCE AGREEMENT

A Sears Maintenance Agreement is available on this product. Contact your nearest Sears store for details.

CUSTOMER RESPONSIBILITIES

- Read and observe the safety rules.
- Follow a regular schedule in maintaining, caring for and using your tractor.
- Follow the instructions under "Customer Responsibilities" and "Storage" sections of this owner's manual.

PRODUCT SPECIFICATIONS

HORSEPOWER:	15.0
GASOLINE CAPACITY AND TYPE:	5 QUARTS UNLEADED REGULAR
OIL TYPE (API-SF/SG):	SAE 30 (above 32°F) SAE 5W-30 (below 32°F)
OIL CAPACITY:	3.0 PINTS
SPARK PLUG: (GAP: .030")	CHAMPION RJ-19LM STD361458
VALVE CLEARANCE:	INTAKE: .005" - .007" EXHAUST: .009" - .011"
GROUND SPEED (MPH):	FORWARD: 1st 1.02 2nd 1.35 3rd 2.10 4th 3.14 5th 4.00 6th 5.12 REVERSE: 1.58
TIRE PRESSURE:	FRONT: 14 PSI REAR: 10 PSI
CHARGING SYSTEM:	3 AMPS BATTERY 5 AMPS HEADLIGHTS
BLADE BOLT TORQUE:	30-35 FT. LBS.

WARNING: This tractor is equipped with an internal combustion engine and should not be used on or near any unimproved forest-covered, brush-covered or grass-covered land unless the engine's exhaust system is equipped with a spark arrester meeting applicable local or state laws (if any). If a spark arrester is used, it should be maintained in effective working order by the operator.

In the state of California the above is required by law (Section 4442 of the California Public Resources Code). Other states may have similar laws. Federal laws apply on federal lands. A spark arrester for the muffler is available through your nearest Sears Authorized Service Center/Department (See REPAIR PARTS section of this manual).

LIMITED TWO YEAR WARRANTY ON CRAFTSMAN RIDING EQUIPMENT

For two (2) years from the date of purchase, if this Craftsman Riding Equipment is maintained, lubricated and tuned up according to the instructions in the owner's manual, Sears will repair or replace, free of charge, any parts found to be defective in material or workmanship.

This Warranty does not cover:

- Expendable items which become worn during normal use, such as blades, spark plugs, air cleaners, belts, etc.
- Tire replacement or repair caused by punctures from outside objects, such as nails, thorns, stumps, or glass.
- Repairs necessary because of operator abuse, negligence, improper storage or accident or the failure to maintain the equipment according to the instructions contained in the owner's manual.
- Riding equipment used for commercial or rental purposes.

LIMITED 90 DAY WARRANTY ON BATTERY

For ninety (90) days from date of purchase, if any battery included with this riding equipment proves defective in material or workmanship and our testing determines the battery will not hold a charge, Sears will replace the battery at no charge.

IN-HOME WARRANTY SERVICE ON YOUR CRAFTSMAN RIDING EQUIPMENT IS AVAILABLE AT NO-CHARGE FOR 30 DAYS FROM THE DATE OF PURCHASE. PLEASE CONTACT YOUR NEAREST SERVICE CENTER. AFTER 30 DAYS FROM THE DATE OF PURCHASE, WARRANTY SERVICE IS AVAILABLE BY TAKING YOUR CRAFTSMAN RIDING EQUIPMENT TO YOUR NEAREST SEARS SERVICE CENTER. (IN-HOME WARRANTY SERVICE WILL STILL BE AVAILABLE AFTER 30 DAYS FROM THE DATE OF PURCHASE BUT A STANDARD TRIP CHARGE WILL APPLY.) THIS WARRANTY APPLIES ONLY WHILE THIS PRODUCT IS IN THE UNITED STATES.

This Warranty gives you specific legal rights, and you may also have other rights which may vary from state to state.

SEARS, ROEBUCK AND CO., D/817 WA, HOFFMAN ESTATES, IL 60179

TABLE OF CONTENTS

SAFETY RULES	2	OPERATION	10-14
PRODUCT SPECIFICATIONS	3	MAINTENANCE SCHEDULE	15
CUSTOMER RESPONSIBILITIES	3, 15-19	SERVICE AND ADJUSTMENTS	20-25
WARRANTY	3	STORAGE	26
TABLE OF CONTENTS	4	TROUBLESHOOTING	27-28
INDEX	4	REPAIR PARTS - TRACTOR	30-47
TRACTOR ACCESSORIES	5	REPAIR PARTS - ENGINE	48-53
ASSEMBLY	7-9	PARTS ORDERING/SERVICE	BACK PAGE





INDEX

A		E		O	
Accessories.....	5	Electrical:		Oil:	
Adjustments:		Interlocks and Relays	24	Cold Weather Conditions	13,17
Brake	22	Schematic	29	Engine	17
Carburetor	25	Wiring Diagram	30	Storage	26
Mower:		Engine:		Operation	10-14
Front-To-Back	21	Air Filter	18	Operating Mower	13
Side-To-Side	21	Air Screen	18	Options:	
Throttle Control Cable	24	Cooling Fins, Engine	18	Accessories	5
Air Filter, Engine	18	Oil Change	17	Spark Arrester	3,40
Air Screen, Engine	18	Oil Level	13,17	P	
Assembly	7-9	Oil Type	17	Parking Brake	11-12
B		Preparation	13	Parts Bag	6
Battery:		Repair Parts	48-53	Parts, Replacement/Repair	30-47
Charging	7-8	Starting	14	Product Specifications	3
Cleaning	17	Storage	26	R	
Connecting	7-8	F		Repair Parts	30-47
Starting with Weak Battery	23	Filters:		S	
Storage	26	Air	18	Safety Rules	2
Terminals	17	Fuel	19	Seat	8
Belts:		Fuel:		Service and Adjustments	20-25
Motion Drive		Type	13	Brake	22
Removal/Replacement	22	Storage	26	Carburetor	25
Mower Blade Drive		Fuse	24	Fuse	24
Removal/Replacement	22	G		Hood Removal/Installation	24
Blade:		Gauge Wheels	8	Motion Drive Belt	
Sharpening	16	H		Removal/Replacement	22
Replacement	16	Hood Removal/Installation	24	Mower Blade Drive Belt	
Brake Adjustment	22	L		Removal/Replacement	22
C		Leveling Mower Deck	21	Mower Adjustment:	
Carburetor Adjustment	25	Lubrication Chart	15	Front-to-Back	21
Controls, Tractor	11	M		Side-to-Side	21
Customer Responsibilities	15-19	Maintenance Schedule	15	Mower Installation	20
Engine:		Mower:		Mower Removal	20
Air Filter	18	Adjustment, Front-to-Back	21	Tire Care	8,16,23
Air Screen, Engine	18	Adjustment, Side-to-Side	21	Slope Guide Sheet	55
Battery	17	Blade Sharpening	16	Spark Plugs	19
Cooling Fins, Engine	18	Blade Replacement	16	Specifications	3
Engine Oil	17	Cutting Height	12	Starting the Engine	13-14
Fuel Filter	19	Installation	20	Steering Wheel	7,23
Spark Plugs	19	Operation	13	Stopping the Tractor	12
Tractor:		Removal	20	Storage	26
Blades	16	Mowing Tips	14	T	
Lubrication Chart	15	Muffler	19	Throttle Control Cable Adjustment	24
Maintenance Schedule	15	Spark Arrester	3,40	Tires	8,16,23
Tire Care	8,16,23	Mulcher Plate	10	Trouble Shooting Chart	27-28
Cutting Height, Mower	12	N		Transaxle Repair Parts	46-47
D		O		W	
				Warranty	3
				Wiring Diagram	30
				Wiring Schematic	29

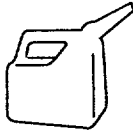

ACCESSORIES AND ATTACHMENTS

These accessories and attachments were available through most Sears retail outlets and service centers when the tractor was purchased. Most Sears stores can order these items for you when you provide the model number of your tractor.

ENGINE

SPARK PLUG	GAS CAN	ENGINE OIL	FUEL STABILIZER	AIR FILTER
				

MAINTENANCE

BLADES	BELTS
	

PERFORMANCE

Sears offers a wide variety of attachments that fit your tractor. Many of these are listed below with brief explanations of how they can help you. This list was current at the time of publication; however, it may change in future years - more attachments may be added, changes may be made in these attachments, or some may no longer be available or fit your model. **Contact your nearest Sears store for the accessories and attachments that are available for your tractor.**

Most of these attachments do not require additional hitches or conversion kits (those that do are indicated) and are designed for easy attaching and detaching.

AERATOR promotes deep root growth for a healthy lawn. Tapered 2.5-inch steel spikes mounted on 10-inch diameter discs puncture holes in soil at close intervals to let moisture soak in. Steel weight tray for increased penetration.

BAGGER lets you collect grass clippings and leaves for a healthier, neater looking lawn. Two Permanex containers hold 30-gallon plastic bags.

BUMPER protects front end of tractor from damage.

CARTS make hauling easy. Variety of sizes available, plus accessories such as side panel kits, tool caddy, cart cover, protective mat and dolly.

CORING AERATOR takes small plugs out of soil to allow moisture and nutrients to reach grass roots. 36-inch swath. 24 hardened steel coring tips. 150 lb. capacity weight tray.

EASY OIL DRAIN VALVE makes oil changes easier, faster.

FRONT NOSE ROLLER canters in front of mower deck to reduce chances of "scalping" on uneven terrain.

GANG HITCH lets you tow 2 or 3 pull-behind attachments at once, such as sweepers, dethatchers, aerators (not for use with rollers, carts or other heavy attachments).

GAUGE WHEELS on both sides of the mower deck reduce chances of "scalping" on uneven terrain. For mower decks not so equipped.

MULCH RAKE/DETHATCHER loosens soil and flips thatch and matted leaves to lawn surface for easy pickup. Twenty spring tine teeth. Useful to prepare bare areas for seeding. Available for front or rear mounting. **HIGH PERFORMANCE REEL-ACTION SPRING TINE DETHATCHER** covers 36-inch wide path and tosses thatch into large hopper. Mounts behind tractor.

MULCHING CLOSE-OUT PLATE KIT, once installed, lets you mulch, discharge or bag clippings (bagger optional) without changing blades. For models not equipped as 3-in-1 Convertible mowers. See "MOWER" in the Repair Parts section of this manual.

RAMP TOPS AND FEET let you load and unload tractor from a pickup truck. Use with 2 x 8 or 2 x 10 lumber.

ROLLER for smoother lawn surface. 36-inch wide, 18-inch diameter water-tight drum holds up to 390 lbs. of weight. Rounded edges prevent harm to turf. Adjustable scraper automatically cleans drum.

SNOW BLADE for snow removal only. 14-inch high, 48-inch wide blade clears 42-inch path when angled left or right. Raises, lowers with side lever. Adjustable skids; replaceable, reversible scraper bar. (Use with tire chains and wheel weights and/or rear drawbar weight.)

SNOWTHROWER has 40-inch swath. Drum-type auger handles powdery and wet/heavy snow. Mounts easily with simple pin arrangement. Discharge chute adjusts from tractor seat. 6-inch diameter spout discharges snow 10 to 50 feet. Lift controlled at tractor seat. (Use with chains and wheel weights and/or rear drawbar weight.)

SPRAYERS use 12-volt DC electric motor that connects to the tractor battery or other 12-volt source. Includes booms for automatic spraying and hand held wand for spot spraying. Wand has adjustable spray pattern. For applying herbicides, insecticides, fungicides and liquid fertilizers.

SPREADER/SEEDERS make seeding, fertilizing, and weed killing easy. Broadcast spreaders are also useful for granular de-icers and sand.

SWEEPERS let you collect grass clippings and leaves.

TILLER has 5 hp engine and 36-inch swath to prepare seed beds, cultivate and compost garden residue. Tiller has its own built-in lift and depth control system and does NOT require a sleeve hitch. Fits any lawn, yard or garden tractor. Simply hook up to the tractor drawbar and go! **Optional accessories** convert unit for dethatching, aerating, hilling...without tools.

TIRE CHAINS are heavy duty; closely spaced extra-large cross links give smooth ride, outstanding traction.

TRACTOR CAB has heavy duty vinyl fabric over tubular steel frame, ABS plastic top; clear plastic windshield offers 360 degree visibility. Hinged metal doors with catch. Keeps operator warm and dry. Remove vinyl sides and windshields for use as sun protector in summer. **Optional accessories include:** tinted/tempered solid safety glass windshield with hand operated wiper; 12-volt amber caution light for mounting on cab top.

VACS for powerful collection of heavy grass clippings and leaves. **Optional wand attachment** to pick up debris in hard-to-reach places. **VAC/CHIPPER** includes a chipper-shredder.

WEIGHT BRACKET for drawbar for snow removal applications. Uses (1) 55 lb. weight.

WHEEL WEIGHTS for rear wheels provide needed traction for snow removal or dozing heavy materials.

CONTENTS OF HARDWARE PACK

Parts Bag contents shown full size

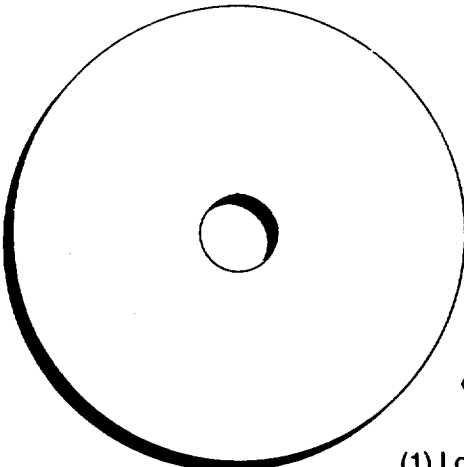

(1) Large Flat Washer



(2) Sheet Metal Screws #10-16 x 1/2



(1) Locknut 3/8-24

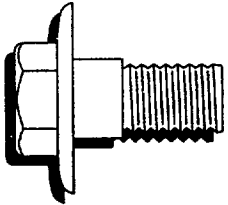

(1) Shoulder Bolt 5/16-18

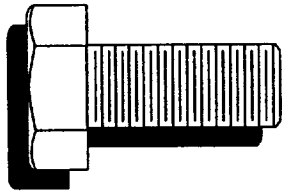

(1) Hex Bolt 1/2-13 x 1

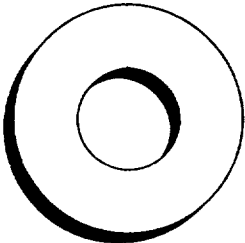

(1) Washer 17/32 x 1-3/16 x 12 Gauge

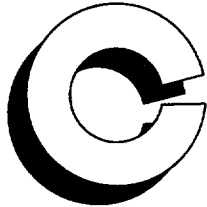

(1) Lock Washer 1/2



(2) Screws #10 x 5/8



(2) Lock Washers #10

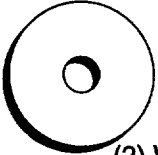

(2) Washers 3/16 x 3/4 x 16 Gauge

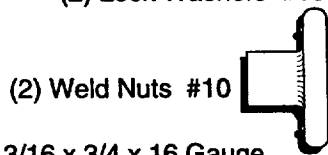

(2) Weld Nuts #10



(2) Hex Bolts 1/4-20 x 3/4



(2) Hex Nuts 1/4-20



(2) Washers 9/32 x 5/8 x 16 Gauge



(2) Lock Washers 1/4

Parts packed separately in carton

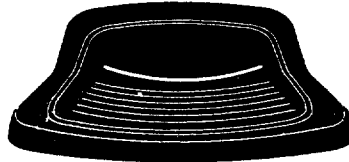

Seat



Steering Boot

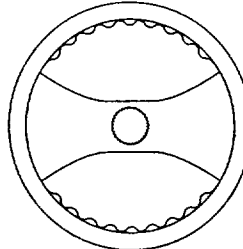

Steering Wheel

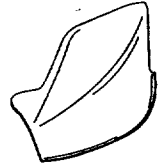

Mulcher Plate

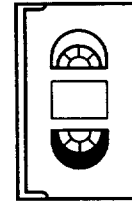

Video Cassette

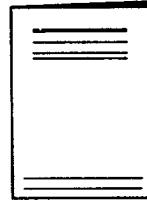

Manual

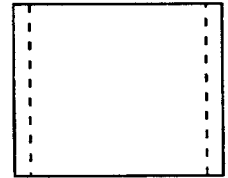

Parts Bag

Parts bag contents not shown full size

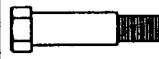

(2) Shoulder Bolts

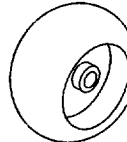

(2) Gauge Wheels



(2) Washers 3/8 x 7/8 x 14 Gauge



(2) Center-lock Nuts



Steering Wheel Adapter



(2) Keys

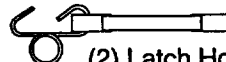

(2) Latch Hook Assemblies



Steering Wheel Insert

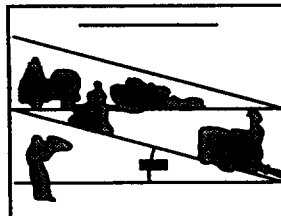

Slope Sheet

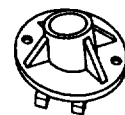

Steering Bushing

ASSEMBLY

Your new tractor has been assembled at the factory with exception of those parts left unassembled for shipping purposes. To ensure safe and proper operation of your tractor all parts and hardware you assemble must be tightened securely. Use the correct tools as necessary to insure proper tightness.

TOOLS REQUIRED FOR ASSEMBLY

A socket wrench set will make assembly easier. Standard wrench sizes are listed.

- | | |
|--------------------|---------------------------------|
| (1) 5/16" wrench | (1) 3/4" Socket w/drive ratchet |
| (2) 7/16" wrenches | Phillips Screwdriver |
| (1) 1/2" wrench | Tire pressure gauge |
| (1) 9/16" wrench | Utility knife |

When right or left hand is mentioned in this manual, it means when you are in the operating position (seated behind the steering wheel).

TO REMOVE TRACTOR FROM CARTON

UNPACK CARTON

- Remove all accessible loose parts and parts cartons from carton (See page 6).
- Cut, from top to bottom, along lines on all four corners of carton, and lay panels flat.
- Check for any additional loose parts or cartons and remove.

BEFORE ROLLING TRACTOR OFF SKID

ATTACH STEERING WHEEL (See Fig. 1)

- Slide the steering bushing over the steering shaft.
- Raise steering shaft forward until screw holes in dash line up with steering bushing. Install two (2) sheet metal screws and tighten securely.
- Position steering boot over steering shaft.
- Place tabs of steering boot over tab slots in dash and push down to secure.
- Slide steering wheel adapter onto upper steering shaft.
- Position front wheels of the tractor so they are pointing straight forward.
- Position steering wheel so cross bars are horizontal (left to right) and slide onto adapter.
- Assemble large flat washer and 3/8-24 locknut and tighten securely.
- Snap steering wheel insert into center of steering wheel.
- Remove protective plastic from tractor hood and grill.

IMPORTANT: CHECK FOR AND REMOVE ANY STAPLES IN SKID THAT MAY PUNCTURE TIRES WHERE TRACTOR IS TO ROLL OFF SKID.

TO ROLL TRACTOR OFF SKID (See Fig. 8)

Raise attachment lift lever to its highest position.

- Release parking brake by depressing clutch/brake pedal.
- Place gearshift lever in neutral (N) position.
- Roll tractor backwards off skid.
- Remove banding holding discharge guard up against tractor.

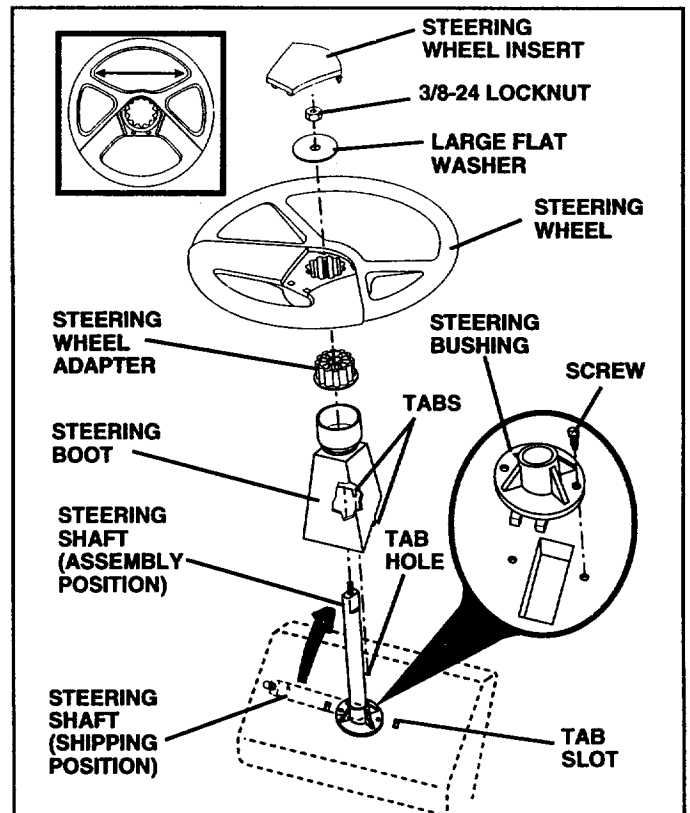

FIG. 1

CONNECT BATTERY (See Figs. 2 and 3)



CAUTION: Do not short battery terminals. Before connecting battery, remove metal bracelets, wristwatch bands, rings, etc.

Positive terminal must be connected first to prevent sparking from accidental grounding.

- Remove cardboard packing from seat pan and lift seat pan to raised position.
 - Open battery box door.
 - Be sure battery drain tube is attached to battery box.
 - Remove terminal protective caps and discard.
 - If this battery is put into service after month and year indicated on label (label located between terminals) charge battery for minimum of one hour at 6-10 amps.
 - First connect RED battery cable to positive (+) terminal with hex bolt, flat washer, lock washer and hex nut as shown. Tighten securely.
 - Connect BLACK grounding cable to negative (-) terminal with remaining hex bolt, flat washer, lock washer and hex nut. Tighten securely.
 - Close battery box door.
- Open battery box door for:
- Inspection for secure connections (to tighten hardware).
 - Inspection for corrosion.
 - Testing battery.
 - Jumping (if required).
 - Periodic charging.

ASSEMBLY

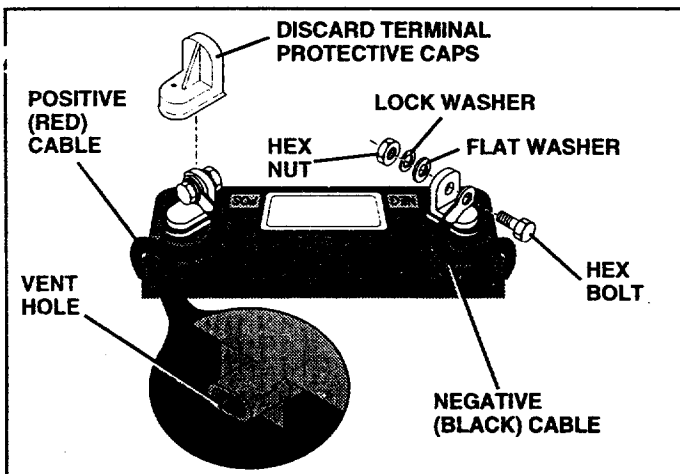

FIG. 2

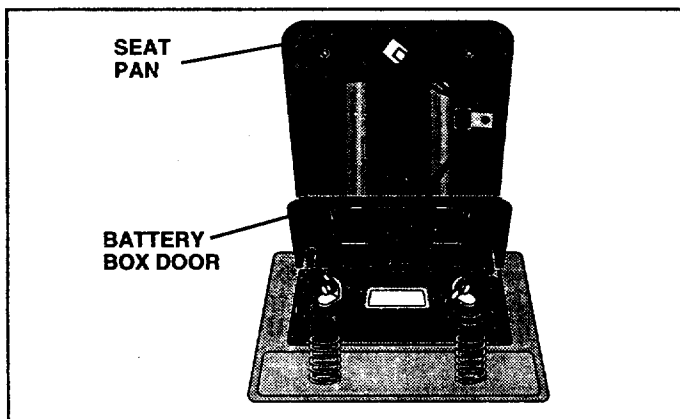

FIG. 3

INSTALL SEAT (See Fig. 4)

Adjust seat before tightening adjustment bolt.

- Remove cardboard packing on seat pan.
- Place seat on seat pan and assemble shoulder bolt.
- Assemble adjustment bolt, lock washer and flat washer loosely. Do not tighten.
- Tighten shoulder bolt securely.
- Lower seat into operating position and sit on seat.
- Slide seat until a comfortable position is reached which allows you to press clutch/brake pedal all the way down.
- Get off seat without moving its adjusted position.
- Raise seat and tighten adjustment bolt securely.

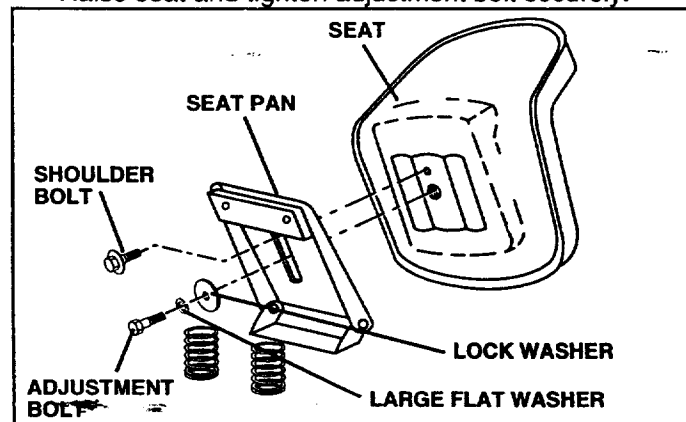

FIG. 4

CHECK TIRE PRESSURE

The tires on your tractor were overinflated at the factory for shipping purposes. Correct tire pressure is important for best cutting performance.

- Reduce tire pressure to PSI shown in "PRODUCT SPECIFICATIONS" on page 3 of this manual.

CHECK DECK LEVELNESS

For best cutting results, mower housing should be properly leveled. See "TO LEVEL MOWER HOUSING" in the Service and Adjustments section of this manual.

CHECK FOR PROPER POSITION OF ALL BELTS

See the figures that are shown for replacing motion and mower blade drive belts in the Service and Adjustments section of this manual. Verify that the belts are routed correctly.

CHECK BRAKE SYSTEM

After you learn how to operate your tractor, check to see that the brake is properly adjusted. See "TO ADJUST BRAKE" in the Service and Adjustments section of this manual.

ASSEMBLE GAUGE WHEELS TO MOWER DECK (See Fig. 5)

Assemble gauge wheels with tractor on a flat level surface.

- Adjust mower to desired cutting height (See "TO ADJUST MOWER CUTTING HEIGHT" in the Operation section of this manual).
- With mower in desired height of cut position, gauge wheels should be assembled so they are slightly off the ground. Install gauge wheel in appropriate hole with shoulder bolt, 3/8" washer and 3/8-16 locknut and tighten securely.
- Repeat for opposite side installing gauge wheel in same adjustment hole.

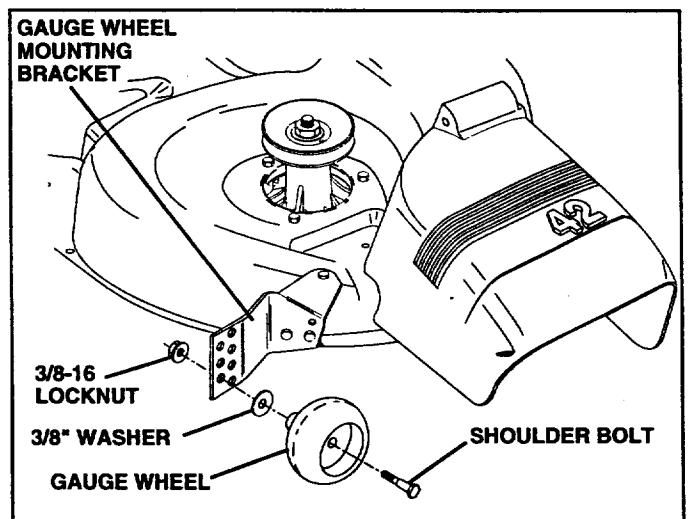

FIG. 5

ASSEMBLY

INSTALL MULCHER PLATE

(See Figs. 6 & 7)

- Install two latch hooks to mulcher plate using screw, washer, lock washer, and weld nut as shown.

NOTE: Pre-assemble weld nut to latch hook by inserting weld nut from the top with hook pointing down.

- Tighten hardware securely.
- Raise and hold deflector shield in upright position.
- Place front of mulcher plate over front of mower deck opening and slide into place, as shown.
- Hook front latch into hole on front of mower deck.
- Hook rear latch into hole on back of mower deck.



CAUTION: Do not remove discharge guard from mower. Raise and hold guard when attaching mulcher plate and allow it to rest on plate while in operation.

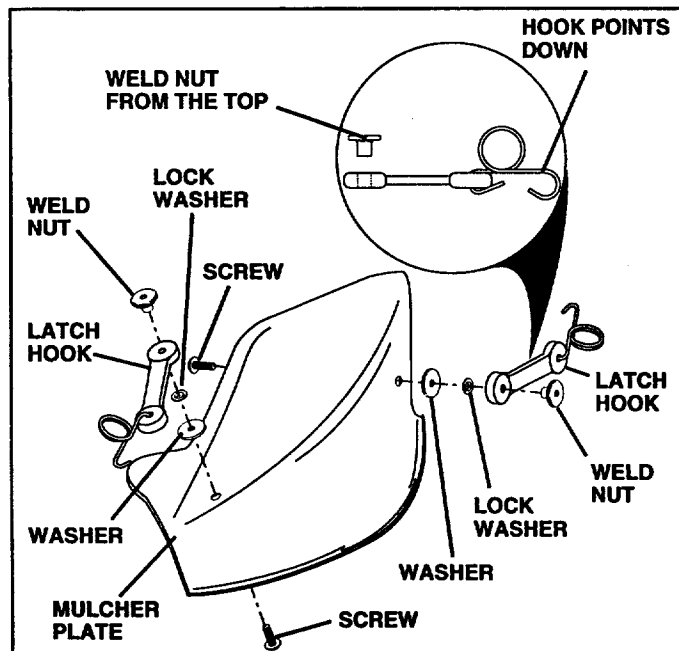

FIG. 6

TO CONVERT TO BAGGING OR DISCHARGING

Simply remove mulcher plate and store in a safe place. Your mower is now ready for discharging or installation of optional grass catcher accessory.

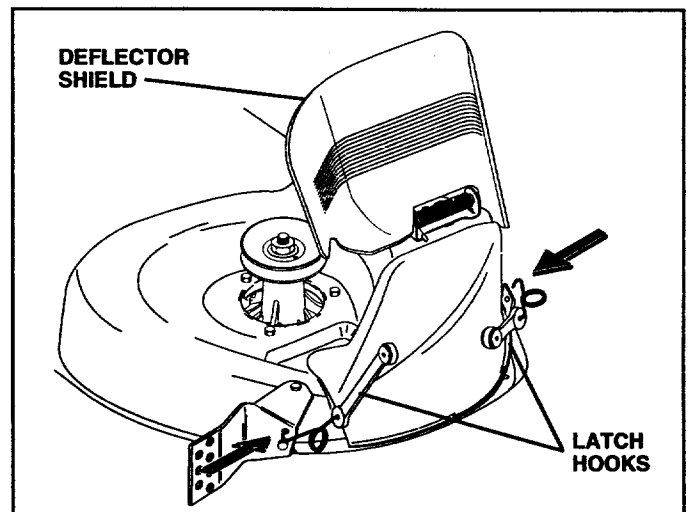

FIG. 7

✓ CHECKLIST

BEFORE YOU OPERATE AND ENJOY YOUR NEW TRACTOR, WE WISH TO ASSURE THAT YOU RECEIVE THE BEST PERFORMANCE AND SATISFACTION FROM THIS QUALITY PRODUCT.

PLEASE REVIEW THE FOLLOWING CHECKLIST:

- ✓ All assembly instructions have been completed.
- ✓ No remaining loose parts in carton.
- ✓ Battery is properly prepared and charged. (Minimum 1 hour at 6 amps).
- ✓ Seat is adjusted comfortably and tightened securely.
- ✓ All tires are properly inflated. (For shipping purposes, the tires were overinflated at the factory).
- ✓ Be sure mower deck is properly leveled side-to-side/ front-to-rear for best cutting results. (Tires must be properly inflated for leveling).
- ✓ Check mower and drive belts. Be sure they are routed properly around pulleys and inside all belt keepers.
- ✓ Check wiring. See that all connections are still secure and wires are properly clamped.

WHILE LEARNING HOW TO USE YOUR TRACTOR, PAY EXTRA ATTENTION TO THE FOLLOWING IMPORTANT ITEMS:

- ✓ Engine oil is at proper level.
- ✓ Fuel tank is filled with fresh, clean, regular unleaded gasoline.
- ✓ Become familiar with all controls - their location and function. Operate them before you start the engine.
- ✓ Be sure brake system is in safe operating condition.

OPERATION

These symbols may appear on your tractor or in literature supplied with the product. Learn and understand their meaning.

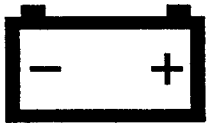

BATTERY



CAUTION OR WARNING



REVERSE



FORWARD



FAST



SLOW



ENGINE ON



ENGINE OFF



OIL PRESSURE



CLUTCH

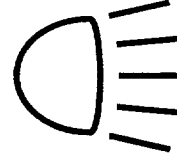

LIGHTS ON



LIGHTS OFF



FUEL



CHOKE



MOWER HEIGHT

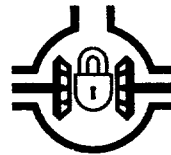

DIFFERENTIAL LOCK



PARKING BRAKE LOCKED



UNLOCKED



MOWER LIFT

R

REVERSE

N

NEUTRAL

H

HIGH

L

LOW

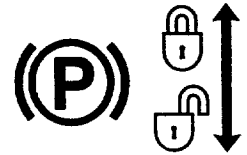

PARKING BRAKE



ATTACHMENT CLUTCH ENGAGED



ATTACHMENT CLUTCH DISENGAGED



IGNITION



DANGER, KEEP HANDS AND FEET AWAY

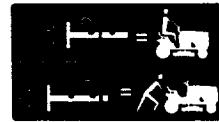

HYDROSTATIC FREE WHEEL
(Hydro Models only)

OPERATION

KNOW YOUR TRACTOR

READ THIS OWNER'S MANUAL AND SAFETY RULES BEFORE OPERATING YOUR TRACTOR

Compare the illustrations with your tractor to familiarize yourself with the locations of various controls and adjustments. Save this manual for future reference.

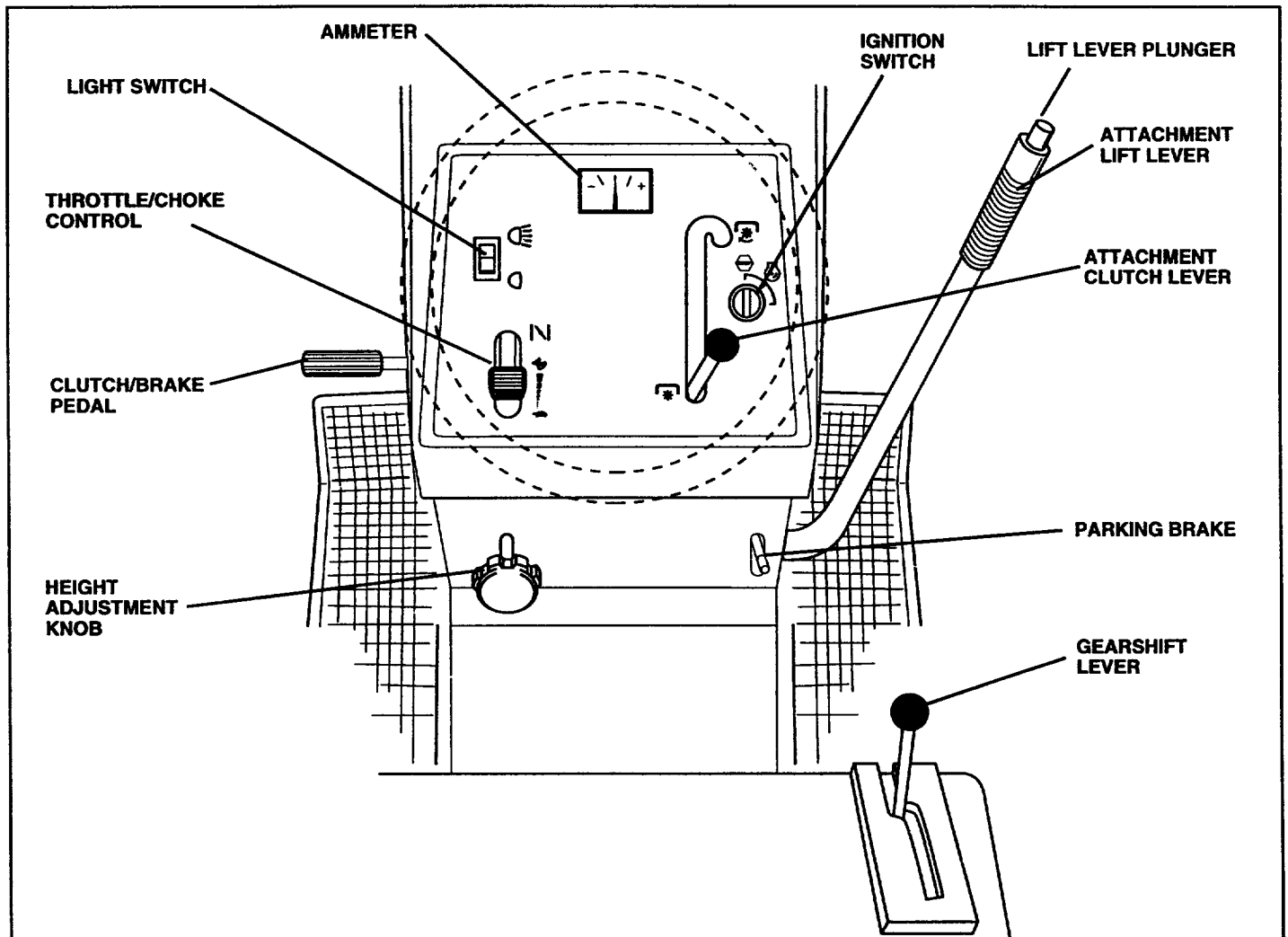

FIG. 8

Our tractors conform to the safety standards of the American National Standards Institute.

ATTACHMENT CLUTCH LEVER: Used to engage the mower blades, or other attachments mounted to your tractor.

LIGHT SWITCH: Turns the headlights on and off.

THROTTLE/CHOKE CONTROL: Used for starting and controlling engine speed.

CLUTCH/BRAKE PEDAL: Used for declutching and braking the tractor and starting the engine.

PARKING BRAKE: Locks clutch/brake pedal into the brake position.

GEARSHIFT LEVER: Selects the speed and direction of tractor.

ATTACHMENT LIFT LEVER: Used to raise and lower the mower deck or other attachments mounted to your tractor.

LIFT LEVER PLUNGER: Used to release attachment lift lever when changing its position.

IGNITION SWITCH: Used for starting and stopping the engine.

HEIGHT ADJUSTMENT KNOB: Used to adjust the mower cutting height.

AMMETER: Indicates battery charging (+) or discharging (-).

OPERATION



The operation of any tractor can result in foreign objects thrown into the eyes, which can result in severe eye damage. Always wear safety glasses or eye shields while operating your tractor or performing any adjustments or repairs. We recommend a wide vision safety mask over the spectacles or standard safety glasses.

HOW TO USE YOUR TRACTOR

TO SET PARKING BRAKE (See Fig. 9)

Your tractor is equipped with an operator presence sensing switch. When engine is running, any attempt by the operator to leave the seat without first setting the parking brake will shut off the engine.

- Depress clutch/brake pedal into full "BRAKE" position and hold.
- Place parking brake lever in "ENGAGED" position and release pressure from clutch/brake pedal. Pedal should remain in "BRAKE" position. Make sure parking brake will hold tractor secure.

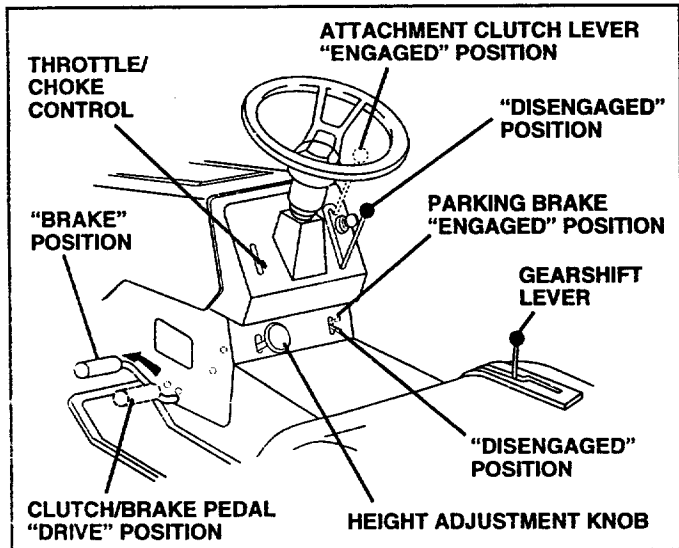

FIG. 9

STOPPING (See Fig. 9)

MOWER BLADES -

- Move attachment clutch lever to "DISENGAGED" position.

GROUND DRIVE -

- Depress clutch/brake pedal into full "BRAKE" position.
- Move gearshift lever to neutral (N) position.

ENGINE -

- Move throttle control to slow (🐢) position.

NOTE: Failure to move throttle control to slow (🐢) position and allowing engine to idle before stopping may cause engine to "backfire".

- Turn ignition key to "OFF" position and remove key. Always remove key when leaving tractor to prevent unauthorized use.
- Never use choke to stop engine.

NOTE: Under certain conditions when tractor is standing idle with the engine running, hot engine exhaust gases may cause "browning" of grass. To eliminate this possibility, always stop engine when stopping tractor on grass areas.



CAUTION: Always stop tractor completely, as described above, before leaving the operator's position; to empty grass catcher, etc.

TO USE THROTTLE CONTROL (See Fig. 9)

Always operate engine at full throttle.

- Operating engine at less than full throttle reduces the battery charging rate.
- Full throttle offers the best bagging and mower performance.

TO MOVE FORWARD AND BACKWARD (See Fig. 9)

The direction and speed of movement is controlled by the gearshift lever.

- Start tractor with clutch/brake pedal depressed and gearshift lever in neutral (N) position.
- Move gearshift and range shift levers to desired position.
- Slowly release clutch/brake pedal to start movement.

IMPORTANT: BRING TRACTOR TO A COMPLETE STOP BEFORE SHIFTING OR CHANGING GEARS. FAILURE TO DO SO WILL SHORTEN THE USEFUL LIFE OF YOUR TRANSAXLE.

TO ADJUST MOWER CUTTING HEIGHT (See Fig. 9)

The cutting height is controlled by turning the height adjustment knob in desired direction.

- Turn knob clockwise (↻) to raise cutting height.
- Turn knob counterclockwise (↺) to lower cutting height.

The cutting height range is approximately 1-1/2" to 4". The heights are measured from the ground to the blade tip with the engine not running. These heights are approximate and may vary depending upon soil conditions, height of grass and types of grass being mowed.

- The average lawn should be cut to approximately 2-1/2 inches during the cool season and to over 3 inches during hot months. For healthier and better looking lawns, mow often and after moderate growth.
- For best cutting performance, grass over 6 inches in height should be mowed twice. Make the first cut relatively high; the second to desired height.

OPERATION

TO OPERATE MOWER (See Fig. 10)

Your tractor is equipped with an operator presence sensing switch. Any attempt by the operator to leave the seat with the engine running and the attachment clutch engaged will shut off the engine.

- Select desired height of cut.
- Lower mower with attachment lift control.
- Start mower blades by engaging attachment clutch control.
- TO STOP MOWER BLADES - disengage attachment clutch control.



CAUTION: Do not operate the mower without either the entire grass catcher, on mowers so equipped, or the discharge guard in place.

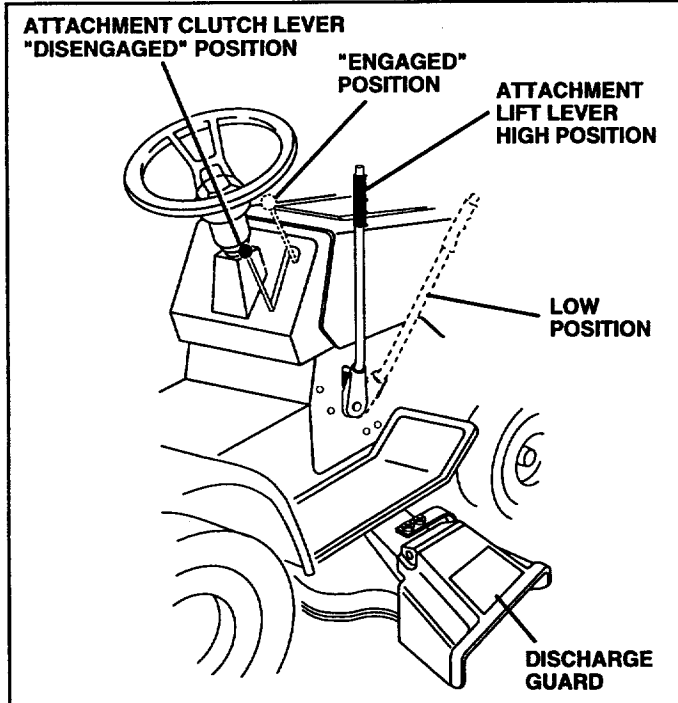

FIG. 10

TO OPERATE ON HILLS



CAUTION: Do not drive up or down hills with slopes greater than 15° and do not drive across any slope.

- Choose the slowest speed before starting up or down hills.
- Avoid stopping or changing speed on hills.
- If slowing is necessary, move throttle control lever to slower position.
- If stopping is absolutely necessary, push clutch/brake pedal quickly to brake position and engage parking brake.

- Move gearshift lever to 1st gear. Be sure you have allowed room for tractor to roll slightly as you restart movement.
- To restart movement, slowly release parking brake and clutch/brake pedal.
- Make all turns slowly.

TO TRANSPORT

- Raise attachment lift to highest position with attachment lift control.
- When pushing or towing your tractor, be sure gearshift lever is in neutral (N) position.
- Do not push or tow tractor at more than five (5) MPH.

NOTE: To protect hood from damage when transporting your tractor on a truck or a trailer, be sure hood is closed and secured to tractor. Use an appropriate means of tying hood to tractor (rope, cord, etc.).

BEFORE STARTING THE ENGINE

CHECK ENGINE OIL LEVEL (See Fig. 16)

- The engine in your tractor has been shipped, from the factory, already filled with summer weight oil.
- Check engine oil with tractor on level ground.
- Remove oil fill cap/dipstick and wipe clean, reinsert the dipstick and screw cap tight, wait for a few seconds, remove and read oil level. If necessary, add oil until "FULL" mark on dipstick is reached. Do not overfill.
- For cold weather operation you should change oil for easier starting (See "OIL VISCOSITY CHART" in the Customer Responsibilities section of this manual).
- To change engine oil, see the Customer Responsibilities section in this manual.

ADD GASOLINE

- Fill fuel tank. Use fresh, clean, regular unleaded gasoline. (Use of leaded gasoline will increase carbon and lead oxide deposits and reduce valve life).

IMPORTANT: WHEN OPERATING IN TEMPERATURES BELOW 32°F (0°C), USE FRESH, CLEAN WINTER GRADE GASOLINE TO HELP INSURE GOOD COLD WEATHER STARTING.

WARNING: Experience indicates that alcohol blended fuels (called gasohol or using ethanol or methanol) can attract moisture which leads to separation and formation of acids during storage. Acidic gas can damage the fuel system of an engine while in storage. To avoid engine problems, the fuel system should be emptied before storage of 30 days or longer. Drain the gas tank, start the engine and let it run until the fuel lines and carburetor are empty. Use fresh fuel next season. See Storage Instructions for additional information. Never use engine or carburetor cleaner products in the fuel tank or permanent damage may occur.



CAUTION: Fill to bottom of gas tank filler neck. Do not overfill. Wipe off any spilled oil or fuel. Do not store, spill or use gasoline near an open flame.

OPERATION

TO START ENGINE (See Fig. 9)

When starting engine for the first time or if engine has run out of fuel, it will take extra cranking time to move fuel from the tank to the engine.

- Depress clutch/brake pedal and set parking brake.
- Place gearshift lever in neutral (N) position.
- Move attachment clutch to "DISENGAGED" position.
- Move throttle control lever to choke (| \ |) position for cold engine start. For warm engine start, move throttle control to fast (⚡) position.
- Insert key into ignition and turn key clockwise to "START" position and release key as soon as engine starts. Do not run starter continuously for more than fifteen seconds per minute. If engine does not start after several attempts, move throttle control to fast (⚡) position, wait a few minutes and try again.
- When engine starts, move throttle control to desired position.
- Allow engine to warm up for a few minutes before engaging drive or attachments.

NOTE: If at a high altitude (above 3000 feet) or in cold temperatures (below 32°F), the carburetor fuel mixture may need to be adjusted for best engine performance. See "TO ADJUST CARBURETOR" in the Service and Adjustments section of this manual.

MOWING TIPS

- Tire chains cannot be used when the mower housing is attached to tractor.
- Mower should be properly leveled for best mowing performance. See "TO LEVEL MOWER HOUSING" in the Service and Adjustments section of this manual.
- The left hand side of mower should be used for trimming.
- Drive so that clippings are discharged onto the area that has been cut. Have the cut area to the right of the machine. This will result in a more even distribution of clippings and more uniform cutting.
- When mowing large areas, start by turning to the right so that clippings will discharge away from shrubs, fences, driveways, etc. After one or two rounds, mow in the opposite direction making left hand turns until finished (See Fig. 11).
- If grass is extremely tall, it should be mowed twice to reduce load and possible fire hazard from dried clippings. Make first cut relatively high; the second to the desired height.
- Do not mow grass when it is wet. Wet grass will plug mower and leave undesirable clumps. Allow grass to dry before mowing.
- Always operate engine at full throttle when mowing to assure better mowing performance and proper discharge of material. Regulate ground speed by selecting a low enough gear to give the mower cutting performance as well as the quality of cut desired.

- When operating attachments, select a ground speed that will suit the terrain and give best performance of the attachment being used.

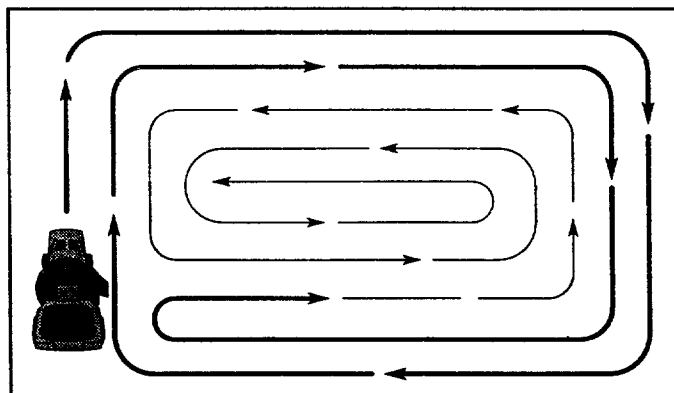

FIG. 11

MULCHING MOWING TIPS

IMPORTANT: FOR BEST PERFORMANCE, KEEP MOWER HOUSING FREE OF BUILT-UP GRASS AND TRASH. CLEAN AFTER EACH USE.

- The special mulching blade will recut the grass clippings many times and reduce them in size so that as they fall onto the lawn they will disperse into the grass and not be noticed. Also, the mulched grass will biodegrade quickly to provide nutrients for the lawn. Always mulch with your highest engine (blade) speed as this will provide the best recutting action of the blades.
- Avoid cutting your lawn when it is wet. Wet grass tends to form clumps and interferes with the mulching action. The best time to mow your lawn is the early afternoon. At this time the grass has dried and the newly cut area will not be exposed to the direct sun.
- For best results, adjust the mower cutting height so that the mower cuts off only the top one-third of the grass blades (See Fig. 12). For extremely heavy mulching, reduce your width of cut and mow slowly.
- Certain types of grass and grass conditions may require that an area be mulched a second time to completely hide the clippings. When doing a second cut, mow across or perpendicular to the first cut path.
- Change your cutting pattern from week to week. Mow north to south one week then change to east to west the next week. This will help prevent matting and graining of the lawn.

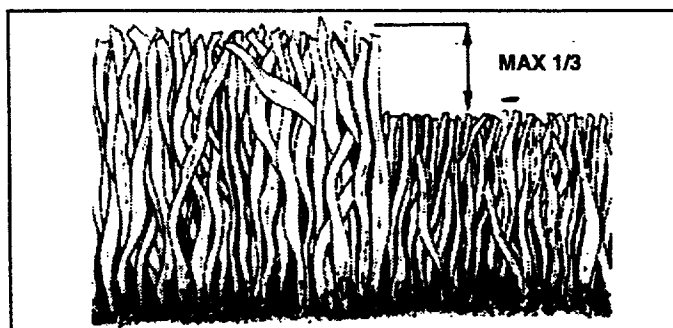

FIG. 12

CUSTOMER RESPONSIBILITIES

MAINTENANCE SCHEDULE FILL IN DATES AS YOU COMPLETE REGULAR SERVICE		SERVICE DATES																
		BEFORE EACH USE	FIRST 2 HOURS	EVERY 8 HOURS	EVERY 25 HOURS	EVERY 50 HOURS	EVERY 100 HOURS	EVERY SEASON	BEFORE STORAGE									
TRACTOR	Check Brake Operation	✓		✓														
	Check Tire Pressure	✓		✓														
	Check for Loose Fasteners	✓						✓ ₇		✓								
	Sharpen/Replace Mower Blades				✓ ₄													
	Lubrication Chart				✓					✓								
	Check Battery Level/Recharge				✓ ₆													
	Clean Battery and Terminals				✓					✓								
	Check Transaxle Cooling				✓													
	Adjust Blade Belt(s) Tension							✓ ₅										
	Adjust Motion Drive Belt(s) Tension							✓ ₅										
ENGINE	Check Engine Oil Level	✓		✓														
	Change Engine Oil		✓		✓ _{1,2,3}					✓								
	Clean Air Filter				✓ ₂													
	Clean Air Screen				✓ ₂													
	Inspect Muffler/Spark Arrester						✓											
	Replace Oil Filter (If equipped)								✓ _{1,2}									
	Clean Engine Cooling Fins								✓ ₂									
	Replace Spark Plug								✓	✓								
	Replace Air Filter Paper Cartridge								✓ ₂									
Replace Fuel Filter										✓								

- 1 - Change more often when operating under a heavy load or in high ambient temperatures.
 2 - Service more often when operating in dirty or dusty conditions.
 3 - If equipped with oil filter, change oil every 50 hours.
 4 - Replace blades more often when mowing in sandy soil.

- 5 - If equipped with adjustable system.
 6 - Not required if equipped with maintenance-free battery.
 7 - Tighten front axle pivot bolt to 35 ft.-lbs. maximum.
 Do not overtighten.

GENERAL RECOMMENDATIONS

The warranty on this tractor does not cover items that have been subjected to operator abuse or negligence. To receive full value from the warranty, operator must maintain tractor as instructed in this manual.

Some adjustments will need to be made periodically to properly maintain your tractor.

All adjustments in the Service and Adjustments section of this manual should be checked at least once each season.

- Once a year you should replace the spark plug, clean or replace air filter, and check blades and belts for wear. A new spark plug and clean air filter assure proper air-fuel mixture and help your engine run better and last longer.

BEFORE EACH USE

- Check engine oil level.
- Check brake operation.
- Check tire pressure.
- Check for loose fasteners.

LUBRICATION CHART

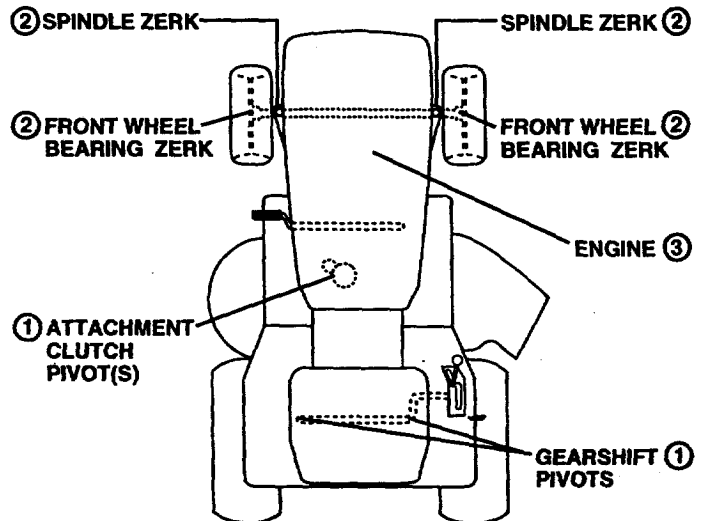

① SAE 30 OR 10W30 MOTOR OIL

② GENERAL PURPOSE GREASE

③ REFER TO CUSTOMER RESPONSIBILITIES "ENGINE" SECTION

IMPORTANT: DO NOT OIL OR GREASE THE PIVOT POINTS WHICH HAVE SPECIAL NYLON BEARINGS. VISCOUS LUBRICANTS WILL ATTRACT DUST AND DIRT THAT WILL SHORTEN THE LIFE OF THE SELF-LUBRICATING BEARINGS. IF YOU FEEL THEY MUST BE LUBRICATED, USE ONLY A DRY, POWDERED GRAPHITE TYPE LUBRICANT SPARINGLY.

CUSTOMER RESPONSIBILITIES

TRACTOR

Always observe safety rules when performing any maintenance.

BRAKE OPERATION

If tractor requires more than six (6) feet stopping distance at high speed in highest gear, then brake must be adjusted. (See "TO ADJUST BRAKE" in the Service and Adjustments section of this manual).

TIRES

- Maintain proper air pressure in all tires (See "PRODUCT SPECIFICATIONS" on page 3 of this manual).
- Keep tires free of gasoline, oil, or insect control chemicals which can harm rubber.
- Avoid stumps, stones, deep ruts, sharp objects and other hazards that may cause tire damage.

BLADE CARE

For best results mower blades must be kept sharp. Replace bent or damaged blades.

BLADE REMOVAL (See Fig. 13)

- Raise mower to highest position to allow access to blades.
- Remove hex bolt, lock washer and flat washer securing blade.
- Install new or resharpened blade with trailing edge up towards deck as shown.
- Reassemble hex bolt, lock washer and flat washer in exact order as shown.
- Tighten bolt securely (30-35 Ft. Lbs. torque).

IMPORTANT: BLADE BOLT IS GRADE 8 HEAT TREATED.

NOTE: We do not recommend sharpening blade - but if you do, be sure the blade is balanced.

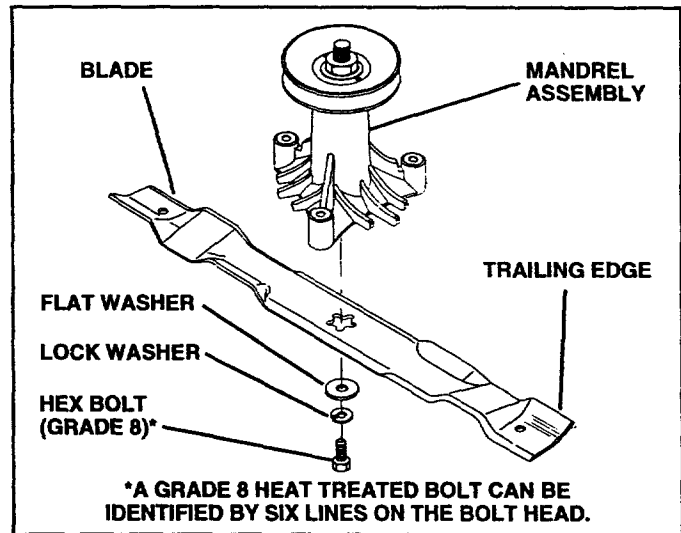

FIG. 13

TO SHARPEN BLADE (See Fig. 14)

Care should be taken to keep the blade balanced. An unbalanced blade will cause excessive vibration and eventual damage to mower and engine.

- The blade can be sharpened with a file or on a grinding wheel. Do not attempt to sharpen while on the mower.
- To check blade balance, you will need a 5/8" diameter steel bolt, pin, or a cone balancer. (When using a cone balancer, follow the instructions supplied with balancer).
- Slide blade on to an unthreaded portion of the steel bolt or pin and hold the bolt or pin parallel with the ground. If blade is balanced, it should remain in a horizontal position. If either end of the blade moves downward, sharpen the heavy end until the blade is balanced.

NOTE: Do not use a nail for balancing blade. The lobes of the center hole may appear to be centered, but are not.

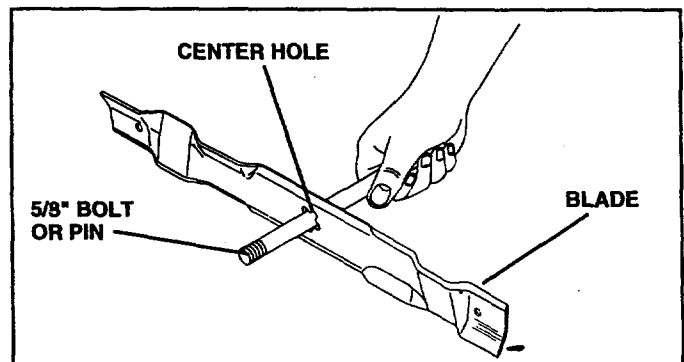

FIG. 14

CUSTOMER RESPONSIBILITIES

BATTERY

Your tractor has a battery charging system which is sufficient for normal use. However, periodic charging of the battery with an automotive charger will extend its life.

- Keep battery and terminals clean.
- Keep battery bolts tight.
- Keep small vent holes open (See "CONNECT BATTERY" in the Assembly section of this manual).
- Recharge at 6 amperes for 1 hour.

TO CLEAN BATTERY AND TERMINALS

Corrosion and dirt on the battery and terminals can cause the battery to "leak" power.

- Open battery box door.
- Disconnect BLACK battery cable first then RED battery cable and remove battery from tractor.
- Wash battery with solution of four tablespoons of baking soda to one gallon of water. Be careful not to get the soda solution into the cells.
- Rinse the battery with plain water and dry.
- Clean terminals and battery cable ends with wire brush until bright.
- Coat terminals with grease or petroleum jelly.
- Reinstall battery (See "CONNECT BATTERY" in the Assembly section of this manual).

V-BELTS

Check V-belts for deterioration and wear after 100 hours of operation and replace if necessary. The belts are not adjustable. Replace belts if they begin to slip from wear.

TRANSAXLE COOLING

Keep transaxle free from build-up of dirt and chaff which can restrict cooling.

ENGINE

LUBRICATION

Only use high quality detergent oil rated with API service classification SF or SG. Select the oil's SAE viscosity grade according to your expected operating temperature.

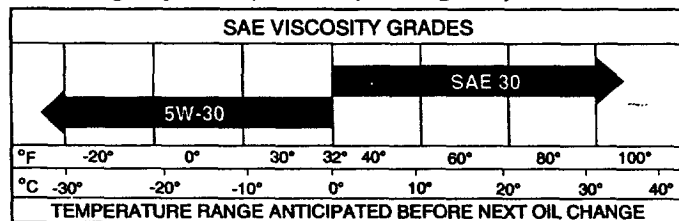

FIG. 15

NOTE: Although multi-viscosity oils (5W30, 10W30 etc.) improve starting in cold weather, these multi-viscosity oils will result in increased oil consumption when used above 32°F. Check your engine oil level more frequently to avoid possible engine damage from running low on oil.

Change the oil after the first two hours of operation and every 25 hours thereafter or at least once a year if the tractor is not used for 25 hours in one year.

Check the crankcase oil level before starting the engine and after each eight (8) hours of operation. Tighten oil fill cap/dipstick securely each time you check the oil level.

TO CHANGE ENGINE OIL (See Figs. 15 and 16)

Determine temperature range expected before oil change. All oil must meet API service classification SF or SG.

- Be sure tractor is on level surface.
- Oil will drain more freely when warm.
- Catch oil in a suitable container.
- Remove oil fill cap/dipstick. Be careful not to allow dirt to enter the engine when changing oil.
- Remove drain plug.
- After oil has drained completely, replace oil drain plug and tighten securely.
- Refill engine with oil through oil fill dipstick tube. Pour slowly. Do not overfill. For approximate capacity see "PRODUCT SPECIFICATIONS" on page 3 of this manual.
- Use gauge on oil fill cap/dipstick for checking level. Be sure dipstick cap is tightened securely for accurate reading. Keep oil at "FULL" line on dipstick.

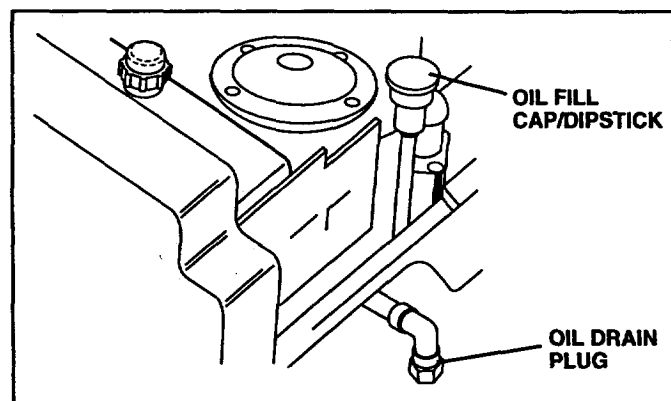

FIG. 16

CUSTOMER RESPONSIBILITIES

AIR FILTER (See Fig. 17)

Your engine will not run properly using a dirty air filter. Clean the foam pre-cleaner after every 25 hours of operation or every season. Service paper cartridge every 100 hours of operation or every season, whichever occurs first.

Service air cleaner more often under dusty conditions.

- Remove knob(s) and cover.

TO SERVICE PRE-CLEANER

- Slide foam pre-cleaner off cartridge.
- Wash it in liquid detergent and water.
- Squeeze it dry in a clean cloth.
- Saturate it in engine oil. Wrap it in clean, absorbent cloth and squeeze to remove excess oil.
- If very dirty or damaged, replace pre-cleaner.
- Reinstall pre-cleaner over cartridge.
- Reinstall cover and secure with knob(s).

TO SERVICE CARTRIDGE

- Remove cartridge nut.
- Carefully remove cartridge to prevent debris from entering carburetor. Clean base carefully to prevent debris from entering carburetor.
- Clean cartridge by tapping gently on flat surface. If very dirty or damaged, replace cartridge.
- Reinstall cartridge, nut, pre-cleaner, cover and secure with knob(s).

IMPORTANT: PETROLEUM SOLVENTS, SUCH AS KEROSENE, ARE NOT TO BE USED TO CLEAN THE CARTRIDGE. THEY MAY CAUSE DETERIORATION OF THE CARTRIDGE. DO NOT OIL CARTRIDGE. DO NOT USE PRESSURIZED AIR TO CLEAN OR DRY CARTRIDGE.

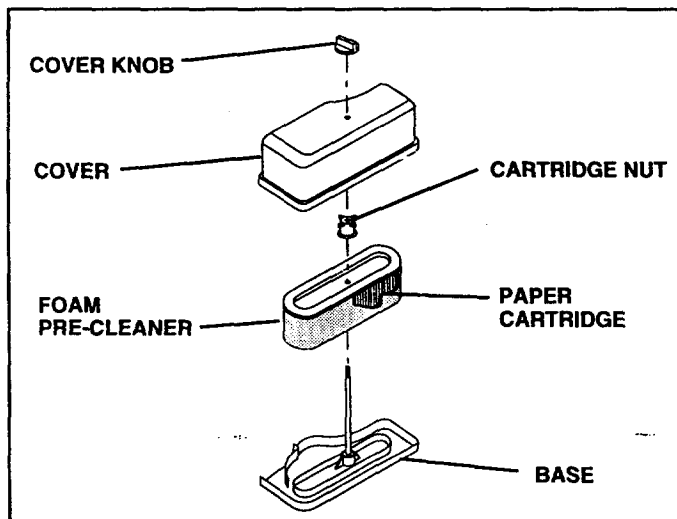

FIG. 17

CLEAN AIR SCREEN (See Fig. 18)

Air screen must be kept free of dirt and chaff to prevent engine damage from overheating. Clean with a wire brush or compressed air to remove dirt and stubborn dried gum fibers.

ENGINE COOLING FINS (See Fig. 18)

Remove any dust, dirt or oil from engine cooling fins to prevent engine damage from overheating.

- Remove screws from blower housing and lift housing and dipstick tube assembly off engine.
- Cover oil fill opening to prevent entry of dirt.
- Use compressed air or stiff bristle brush to thoroughly clean engine cooling fins.
- To reassemble, reverse above procedure.

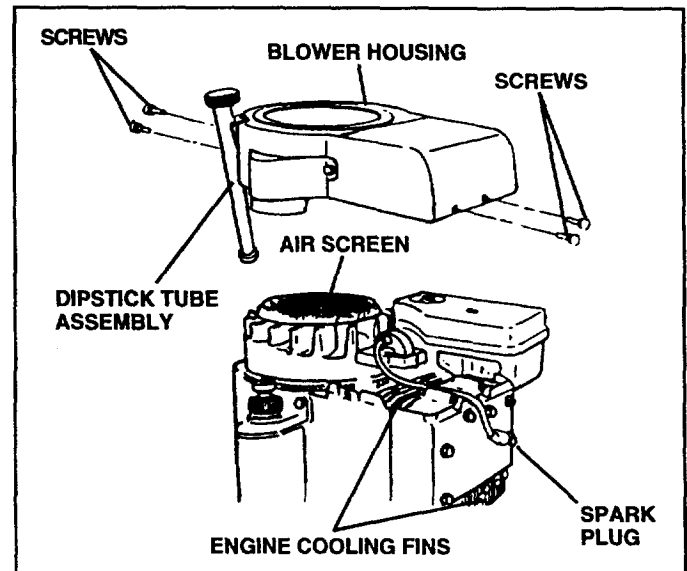

FIG. 18

CUSTOMER RESPONSIBILITIES

MUFFLER

Inspect and replace corroded muffler and spark arrester (if equipped) as it could create a fire hazard and/or damage.

SPARK PLUGS

Replace spark plugs at the beginning of each mowing season or after every 100 hours of operation, whichever occurs first. Spark plug type and gap setting are shown in "PRODUCT SPECIFICATIONS" on page 3 of this manual.

IN-LINE FUEL FILTER (See Fig. 19)

The fuel filter should be replaced once each season. If fuel filter becomes clogged, obstructing fuel flow to carburetor, replacement is required.

- With engine cool, remove filter and plug fuel line sections.
- Place new fuel filter in position in fuel line with arrow pointing towards carburetor.
- Be sure there are no fuel line leaks and clamps are properly positioned.
- Immediately wipe up any spilled gasoline.

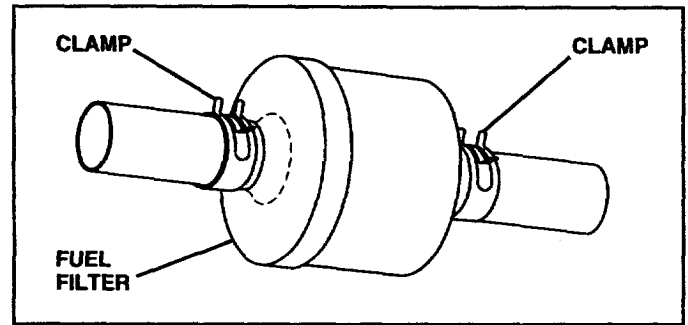

FIG. 19

CLEANING

- Clean engine, battery, seat, finish, etc. of all foreign matter.
- Keep finished surfaces and wheels free of all gasoline, oil, etc.
- Protect painted surfaces with automotive type wax.

We do not recommend using a garden hose to clean your tractor unless the electrical system, muffler, air filter and carburetor are covered to keep water out. Water in engine can result in a shortened engine life.

SERVICE AND ADJUSTMENTS



CAUTION: BEFORE PERFORMING ANY SERVICE OR ADJUSTMENTS:

- Depress clutch/brake pedal fully and set parking brake.
- Place gearshift lever in neutral (N) position.
- Place attachment clutch in "DISENGAGED" position.
- Turn ignition key "OFF" and remove key.
- Make sure the blades and all moving parts have completely stopped.
- Disconnect spark plug wire from spark plug and place wire where it cannot come in contact with plug.

TRACTOR

TO REMOVE MOWER (See Fig. 20)

Mower will be easier to remove from the right side of tractor.

- Place attachment clutch in "DISENGAGED" position.
- Move attachment lift lever forward to lower mower to its lowest position.
- Roll belt off engine pulley.
- Disconnect clutch rod from clutch lever by removing retainer spring.
- Disconnect anti-sway bar from chassis bracket by removing retainer spring.
- Disconnect suspension arms from rear deck brackets by removing retainer springs.
- Disconnect front links from deck by removing retainer springs.
- Raise lift lever to raise suspension arms. Slide mower out from under tractor.

IMPORTANT: IF AN ATTACHMENT OTHER THAN THE MOWER IS TO BE MOUNTED TO THE TRACTOR, THE R.H. AND L.H. SUSPENSION ARMS MUST BE REMOVED FROM TRACTOR.

TO INSTALL MOWER (See Fig. 20)

- Raise attachment lift lever to its highest position.
- Slide mower under tractor with discharge guard to right side of tractor.
- Lower lift lever to its lowest position.
- Install mower in reverse order of removal instructions.

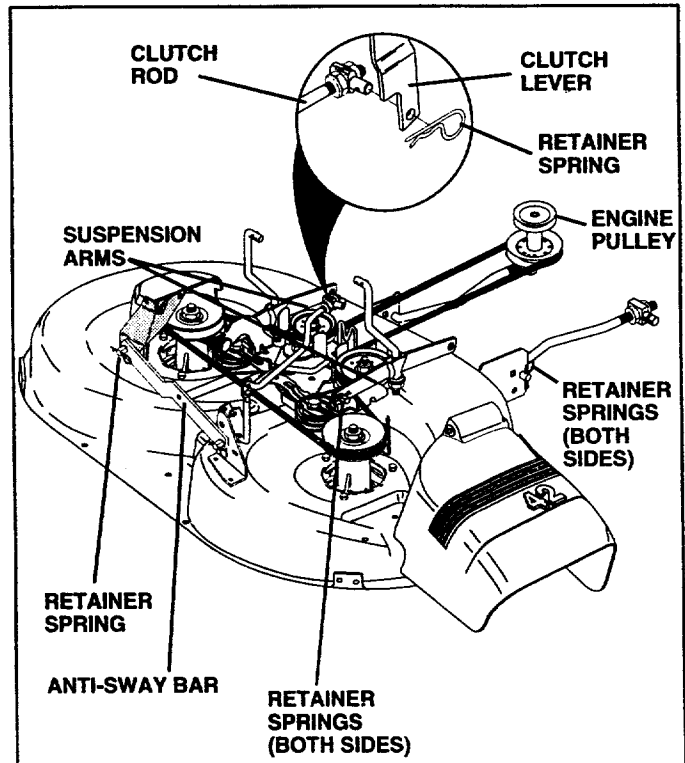

FIG. 20

SERVICE AND ADJUSTMENTS

TO LEVEL MOWER HOUSING

Adjust the mower while tractor is parked on level ground or driveway. Make sure tires are properly inflated (See "PRODUCT SPECIFICATIONS" on page 3 of this manual). If tires are over or underinflated, you will not properly adjust your mower.

SIDE-TO-SIDE ADJUSTMENT (See Figs. 21 and 22)

- Raise mower to its highest position.
- At the midpoint of both sides of mower, measure height from bottom edge of mower to ground. Distance "A" on both sides of mower should be the same or within 1/4" of each other.
- If adjustment is necessary, make adjustment on one side of mower only.
- To raise one side of mower, tighten lift link adjustment nut on that side.
- To lower one side of mower, loosen lift link adjustment nut on that side.

NOTE: Each full turn of adjustment nut will change mower height about 1/8".

- Recheck measurements after adjusting.

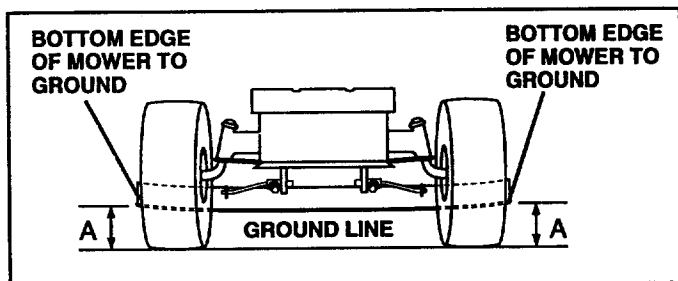

FIG. 21

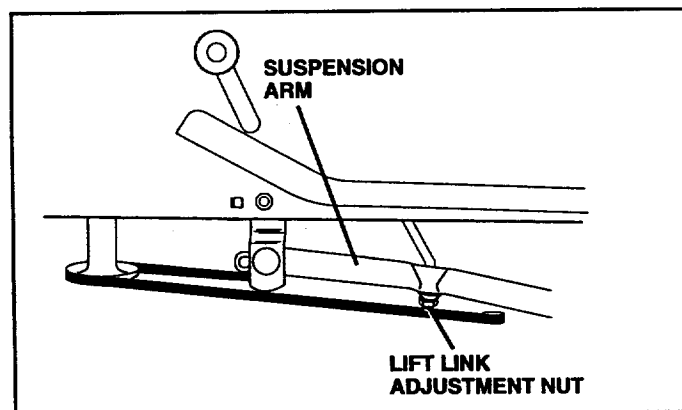

FIG. 22

FRONT-TO-BACK ADJUSTMENT (See Figs. 23 and 24)

IMPORTANT: DECK MUST BE LEVEL SIDE-TO-SIDE. IF THE FOLLOWING FRONT-TO-BACK ADJUSTMENT IS NECESSARY, BE SURE TO ADJUST BOTH FRONT LINKS EQUALLY SO MOWER WILL STAY LEVEL SIDE-TO-SIDE.

To obtain the best cutting results, the mower housing should be adjusted so that the front is approximately 1/4" to 3/4" lower than the rear when the mower is in its highest position.

Check adjustment on right side of tractor. Measure distance "D" directly in front and behind the mandrel at bottom edge of mower housing as shown.

- Before making any necessary adjustments, check that both front links are equal in length. Both links should be approximately 10-3/8".
- If links are not equal in length, adjust one link to same length as other link.
- To lower front of mower loosen nut "E" on both front links an equal number of turns.
- When distance "D" is 1/4" to 3/4" lower at front than rear, tighten nuts "F" against trunnion on both front links.
- To raise front of mower, loosen nut "F" from trunnion on both front links. Tighten nut "E" on both front links an equal number of turns.
- When distance "D" is 1/4" to 3/4" lower at front than rear, tighten nut "F" against trunnion on both front links.
- Recheck side-to-side adjustment.

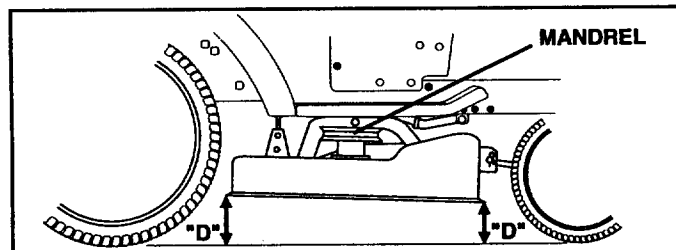

FIG. 23

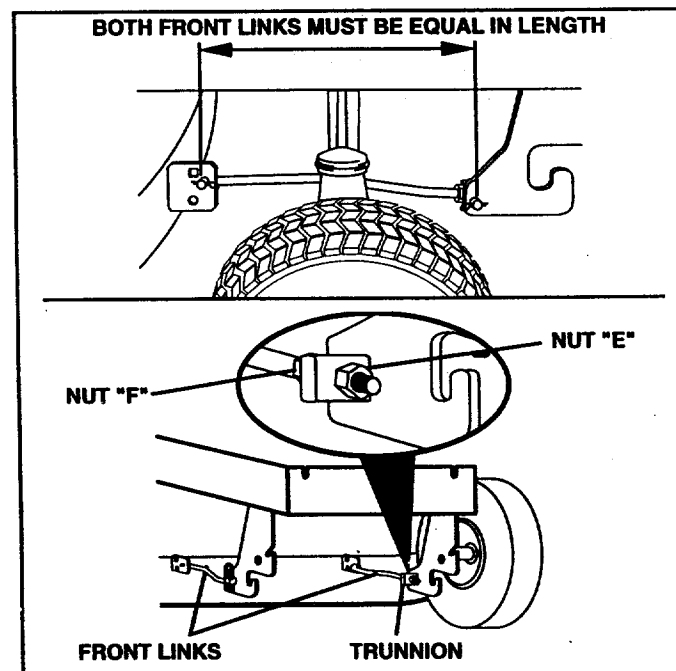

FIG. 24

SERVICE AND ADJUSTMENTS

TO REPLACE MOWER BLADE DRIVE BELT (See Fig. 25)

The mower blade drive belt may be replaced without tools. Park the tractor on level surface. Engage parking brake.

BELT REMOVAL -

- Remove mower from tractor (See "TO REMOVE MOWER" in this section of this manual).
- Work belt off both mandrel pulleys and idler pulleys.
- Pull belt away from mower.

BELT INSTALLATION -

- Install new belt in reverse order of removal.
- Make sure belt is in all pulley grooves and inside all belt guides.
- Install mower in reverse order of removal instructions.

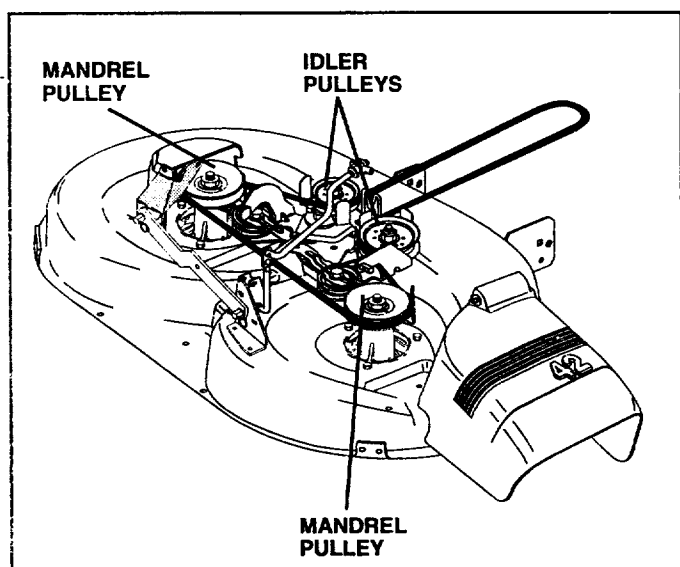

FIG. 25

TO ADJUST BRAKE (See Fig. 26)

Your tractor is equipped with an adjustable brake system which is mounted on the right side of the transaxle.

If tractor requires more than six (6) feet stopping distance at high speed in highest gear, then brake must be adjusted.

- Depress clutch/brake pedal and engage parking brake.
- Measure distance between brake operating arm and nut "A" on brake rod.
- If distance is other than 1-1/2", loosen jam nut and turn nut "A" until distance becomes 1-1/2". Retighten jam nut against nut "A".
- Road test tractor for proper stopping distance as stated above. Readjust if necessary. If stopping distance is still greater than six (6) feet in highest gear, further maintenance is necessary. Contact your nearest authorized service center/department.

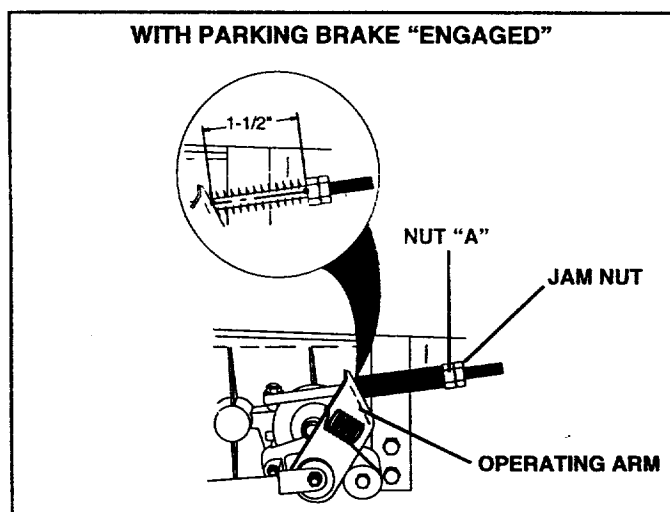

FIG. 26

TO REPLACE MOTION DRIVE BELT (See Fig. 27)

Park the tractor on level surface. Engage parking brake. For assistance, there is a belt installation guide decal on bottom side of left footrest.

- Remove mower (See "TO REMOVE MOWER" in this section of this manual.)
- Remove upper belt keeper.
- Remove belt from stationary idler and clutching idler.
- Pull belt slack toward rear of tractor. Remove belt upwards from transaxle pulley by deflecting belt keepers.
- Pull belt toward front of tractor and remove downwards from around engine pulley.
- Install new belt by reversing above procedure.

IMPORTANT: MAKE SURE UPPER BELT KEEPER IS POSITIONED PROPERLY BETWEEN LOCATOR TABS.

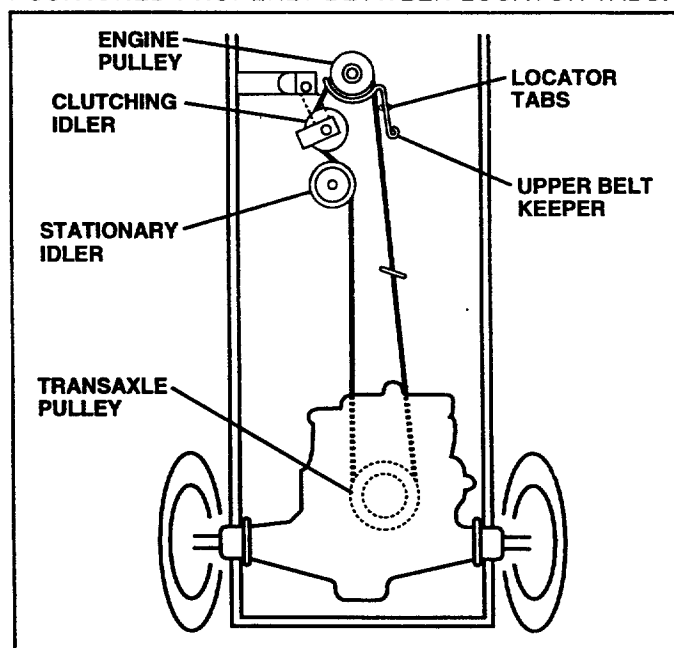

FIG. 27

SERVICE AND ADJUSTMENTS

TO ADJUST STEERING WHEEL ALIGNMENT

If steering wheel crossbars are not horizontal (left to right) when wheels are positioned straight forward, remove steering wheel and reassemble per instructions in the Assembly section of this manual.

FRONT WHEEL TOE-IN/CAMBER

The front wheel toe-in and camber are not adjustable on your tractor. If damage has occurred to affect the front wheel toe-in or camber, contact your nearest authorized service center/department.

TO REMOVE WHEEL FOR REPAIRS (See Fig. 28)

- Block up axle securely.
- Remove axle cover, retaining ring and washers to allow wheel removal (rear wheel contains a square key - Do not lose).
- Repair tire and reassemble.
- On rear wheels only: align grooves in rear wheel hub and axle. Insert square key.
- Replace washers and snap retaining ring securely in axle groove.
- Replace axle cover.

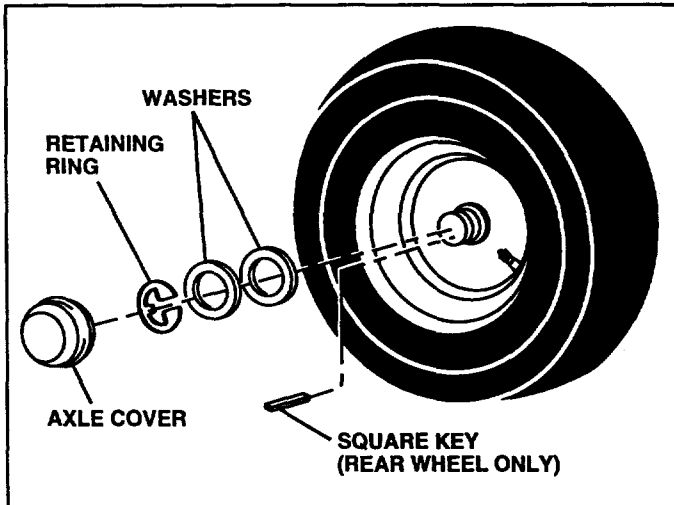

FIG. 28

TO START ENGINE WITH A WEAK BATTERY (See Fig. 29)



CAUTION: Lead-acid batteries generate explosive gases. Keep sparks, flame and smoking materials away from batteries. Always wear eye protection when around batteries.

If your battery is too weak to start the engine, it should be recharged. If "jumper cables" are used for emergency starting, follow this procedure:

IMPORTANT: YOUR UNIT IS EQUIPPED WITH A 12 VOLT NEGATIVE GROUNDED SYSTEM. THE OTHER VEHICLE MUST ALSO BE A 12 VOLT NEGATIVE GROUNDED SYSTEM. DO NOT USE YOUR TRACTOR BATTERY TO START OTHER VEHICLES.

TO ATTACH JUMPER CABLES -

- Connect each end of the RED cable to the POSITIVE (+) terminal of each battery, taking care not to short against chassis.
- Connect one end of the BLACK cable to the NEGATIVE (-) terminal of fully charged battery.
- Connect the other end of the BLACK cable to good CHASSIS GROUND, away from fuel tank and battery.

TO REMOVE CABLES, REVERSE ORDER -

- BLACK cable first from chassis and then from the fully charged battery.
- RED cable last from both batteries.

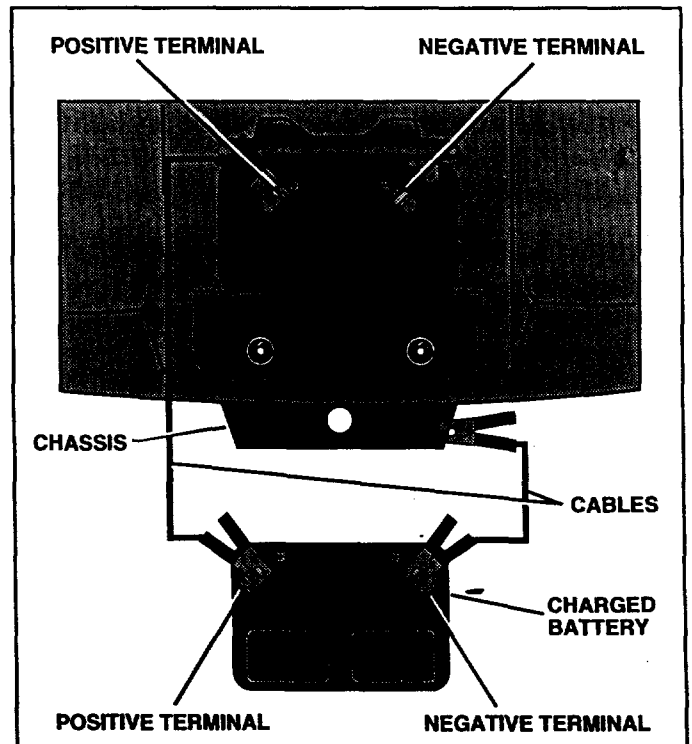

FIG. 29

SERVICE AND ADJUSTMENTS

TO REPLACE HEADLIGHT BULB

- Raise hood.
- Pull bulb holder out of the hole in the backside of the grill.
- Replace bulb in holder and push bulb holder securely back into the hole in the backside of the grill.
- Close hood.

INTERLOCKS AND RELAYS

Loose or damaged wiring may cause your tractor to run poorly, stop running, or prevent it from starting.

- Check wiring. See electrical wiring diagram in the Repair Parts section of this manual.

TO REPLACE FUSE

Replace with 30 amp automotive-type plug-in fuse. The fuse holder is located behind the dash.

TO REMOVE HOOD AND GRILL ASSEMBLY (See Fig. 30)

- Raise hood.
- Unsnap headlight wire connector.
- Stand in front of tractor. Grasp hood at sides, tilt toward engine and lift off of tractor.
- To replace, reverse above procedures.

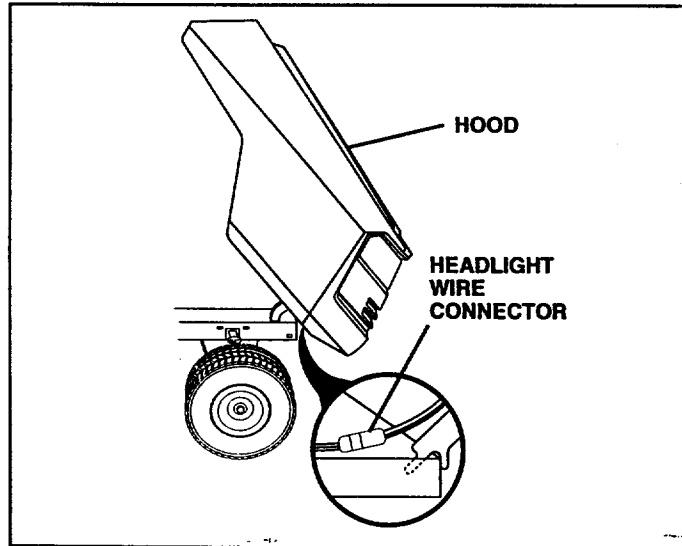

FIG. 30

ENGINE

TO ADJUST THROTTLE CONTROL CABLE (See Fig. 31)

The throttle control has been preset at the factory and adjustment should not be necessary. Check adjustment as described below before loosening cable. If adjustment is necessary, proceed as follows:

- With engine not running, move throttle control lever from slow (S) to choke (N) position. Slowly move lever from choke (N) to fast (F) position.
- Check that holes "A" in governor control lever and hole in governor plate line-up. If holes "A" are not aligned, loosen clamp screw and move throttle cable until holes are aligned. Tighten clamp screw securely.

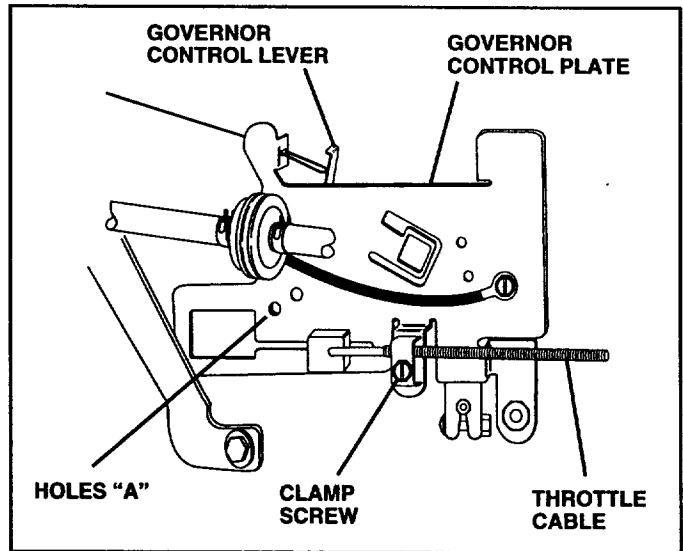

FIG. 31

SERVICE AND ADJUSTMENTS

TO ADJUST CARBURETOR (See Fig. 32)

The carburetor has been preset at the factory and adjustment should not be necessary. However, minor adjustment may be required to compensate for differences in fuel, temperature, altitude or load. If the carburetor does need adjustment, proceed as follows:

In general, turning idle mixture valve **in** (clockwise) decreases the supply of fuel to the engine giving a leaner fuel/air mixture. Turning the idle mixture valve **out** (counterclockwise) increases the supply of fuel to the engine giving a richer fuel/air mixture.

IMPORTANT: DAMAGE TO THE NEEDLE VALVE AND THE SEAT IN CARBURETOR MAY RESULT IF SCREW IS TURNED IN TOO TIGHT.

PRELIMINARY SETTING -

- Air cleaner assembly must be assembled to the carburetor when making carburetor adjustments.
- Be sure the throttle control cable is adjusted properly (see above).
- With engine off turn idle mixture valve **in** (clockwise) closing it finger tight and then turn **out** (counterclockwise) 1 full turn.

FINAL SETTING -

- Start engine and allow to warm for five minutes. Make final adjustments with engine running and shift/motion control lever in neutral (N) position.
- Move throttle control lever to slow (☛) position. With finger, rotate and hold throttle lever against idle speed screw. Turn idle speed screw to attain 1750 RPM.
- While still holding throttle lever against idle speed screw, turn idle mixture valve **in** (clockwise) until engine begins to die and then turn **out** (counterclockwise) until engine runs rough. Turn valve to a point midway between those two positions. Release throttle lever.

ACCELERATION TEST -

- Move throttle control lever from slow (☛) to fast (☜) position. If engine hesitates or dies, turn idle mixture valve **out** (counterclockwise) 1/8 turn. Repeat test and continue to adjust, if necessary, until engine accelerates smoothly.

High speed stop is factory adjusted. Do not adjust - damage may result.

IMPORTANT: NEVER TAMPER WITH THE ENGINE GOVERNOR, WHICH IS FACTORY SET FOR PROPER ENGINE SPEED. OVERSPEEDING THE ENGINE ABOVE THE FACTORY HIGH SPEED SETTING CAN BE DANGEROUS. IF YOU THINK THE ENGINE-GOVERNED HIGH SPEED NEEDS ADJUSTING, CONTACT YOUR NEAREST AUTHORIZED SERVICE CENTER/DEPARTMENT, WHICH HAS PROPER EQUIPMENT AND EXPERIENCE TO MAKE ANY NECESSARY ADJUSTMENTS.

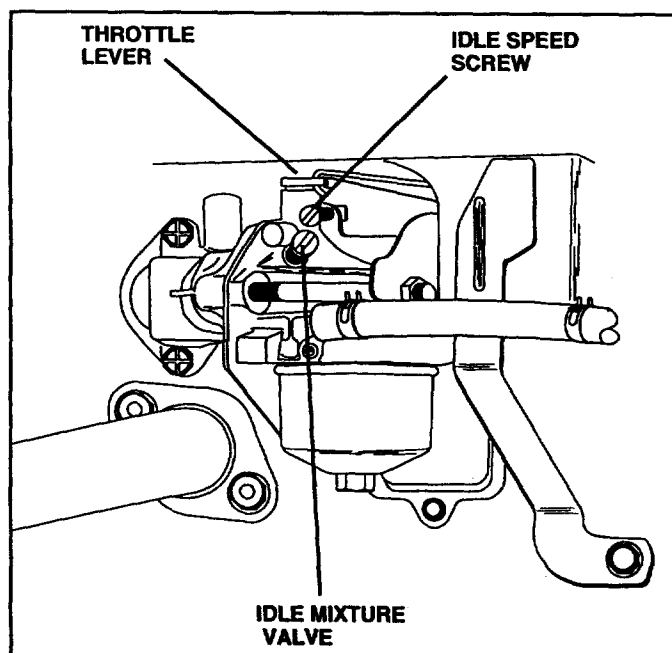

FIG. 32

STORAGE

Immediately prepare your tractor for storage at the end of the season or if the tractor will not be used for 30 days or more.



CAUTION: Never store the tractor with gasoline in the tank inside a building where fumes may reach an open flame or spark. Allow the engine to cool before storing in any enclosure.

TRACTOR

Remove mower from tractor for winter storage. When mower is to be stored for a period of time, clean it thoroughly, remove all dirt, grease, leaves, etc. Store in a clean, dry area.

- Clean entire tractor (See "CLEANING" in the Customer Responsibilities section of this manual).
- Inspect and replace belts, if necessary (See belt replacement instructions in the Service and Adjustments section of this manual).
- Lubricate as shown in the Customer Responsibilities section of this manual.
- Be sure that all nuts, bolts and screws are securely fastened. Inspect moving parts for damage, breakage and wear. Replace if necessary.
- Touch up all rusted or chipped paint surfaces; sand lightly before painting.

BATTERY

- Fully charge the battery for storage.
- After a period of time in storage, battery may require recharging.
- To help prevent corrosion and power leakage during long periods of storage, battery cables should be disconnected and battery cleaned thoroughly (see "TO CLEAN BATTERY AND TERMINALS" in the Customer Responsibilities section of this manual).
- After cleaning, leave cables disconnected and place cables where they cannot come in contact with battery terminals.
- Be sure battery drain tube is securely attached.
- If battery is removed from tractor for storage, do not store battery directly on concrete or damp surfaces.

ENGINE

FUEL SYSTEM

IMPORTANT: IT IS IMPORTANT TO PREVENT GUM DEPOSITS FROM FORMING IN ESSENTIAL FUEL SYSTEM PARTS SUCH AS CARBURETOR, FUEL FILTER, FUEL HOSE, OR TANK DURING STORAGE. ALSO, EXPERIENCE INDICATES THAT ALCOHOL BLENDED FUELS (CALLED GASOHOL OR USING ETHANOL OR METHANOL) CAN ATTRACT MOISTURE WHICH LEADS TO SEPARATION AND FORMATION OF ACIDS DURING STORAGE. ACIDIC GAS CAN DAMAGE THE FUEL SYSTEM OF AN ENGINE WHILE IN STORAGE.

- Drain the fuel tank.
- Start the engine and let it run until the fuel lines and carburetor are empty.
- Never use engine or carburetor cleaner products in the fuel tank or permanent damage may occur.
- Use fresh fuel next season.

NOTE: Fuel stabilizer is an acceptable alternative in minimizing the formation of fuel gum deposits during storage. Add stabilizer to gasoline in fuel tank or storage container. Always follow the mix ratio found on stabilizer container. Run engine at least 10 minutes after adding stabilizer to allow the stabilizer to reach the carburetor. Do not drain the gas tank and carburetor if using fuel stabilizer.

ENGINE OIL

Drain oil (with engine warm) and replace with clean engine oil. (See "ENGINE" in the Customer Responsibilities section of this manual).

CYLINDERS

- Remove spark plug(s).
- Pour one ounce of oil through spark plug hole(s) into cylinder(s).
- Turn ignition key to "START" position for a few seconds to distribute oil.
- Replace with new spark plug(s).

OTHER

- Do not store gasoline from one season to another.
- Replace your gasoline can if your can starts to rust. Rust and/or dirt in your gasoline will cause problems.
- If possible, store your tractor indoors and cover it to give protection from dust and dirt.
- Cover your tractor with a suitable protective cover that does not retain moisture. Do not use plastic. Plastic cannot breathe which allows condensation to form and will cause your tractor to rust.

IMPORTANT: NEVER COVER TRACTOR WHILE ENGINE AND EXHAUST AREAS ARE STILL WARM.

TROUBLESHOOTING POINTS

PROBLEM	CAUSE	CORRECTION
Will not start	<ol style="list-style-type: none"> 1. Out of fuel. 2. Engine not "CHOKED" properly. 3. Engine flooded. 4. Bad spark plug. 5. Dirty air filter. 6. Dirty fuel filter. 7. Water in fuel. 8. Loose or damaged wiring. 9. Carburetor out of adjustment. 10. Engine valves out of adjustment. 	<ol style="list-style-type: none"> 1. Fill fuel tank. 2. See "TO START ENGINE" in Operation section. 3. Wait several minutes before attempting to start. 4. Replace spark plug. 5. Clean/replace air filter. 6. Replace fuel filter. 7. Drain fuel tank and carburetor, refill tank with fresh gasoline and replace fuel filter. 8. Check all wiring. 9. Contact an authorized service facility. 10. Contact an authorized service facility.
Hard to start	<ol style="list-style-type: none"> 1. Dirty air filter. 2. Bad spark plug. 3. Weak or dead battery. 4. Dirty fuel filter. 5. Stale or dirty fuel. 6. Loose or damaged wiring. 7. Carburetor out of adjustment. 8. Engine valves out of adjustment. 	<ol style="list-style-type: none"> 1. Clean/replace air filter. 2. Replace spark plug. 3. Recharge or replace battery. 4. Replace fuel filter. 5. Drain fuel tank and refill with fresh gasoline. 6. Check all wiring. 7. Contact an authorized service facility. 8. Contact an authorized service facility.
Engine will not turn over	<ol style="list-style-type: none"> 1. Clutch/brake pedal not depressed. 2. Attachment clutch is engaged. 3. Weak or dead battery. 4. Blown fuse. 5. Corroded battery terminals. 6. Loose or damaged wiring. 7. Faulty ignition switch. 8. Faulty solenoid or starter. 9. Faulty operator presence switch(es). 	<ol style="list-style-type: none"> 1. Depress clutch/brake pedal. 2. Disengage attachment clutch. 3. Recharge or replace battery. 4. Replace fuse. 5. Clean battery terminals. 6. Check all wiring. 7. Check/replace ignition switch. 8. Check/replace solenoid or starter. 9. Contact an authorized service facility.
Engine clicks but will not start	<ol style="list-style-type: none"> 1. Weak or dead battery. 2. Corroded battery terminals. 3. Loose or damaged wiring. 4. Faulty solenoid or starter. 	<ol style="list-style-type: none"> 1. Recharge or replace battery. 2. Clean battery terminals. 3. Check all wiring. 4. Check/replace solenoid or starter.
Loss of power	<ol style="list-style-type: none"> 1. Cutting too much grass/too fast. 2. Throttle in "CHOKE" position. 3. Build-up of grass, leaves and trash under mower. 4. Dirty air filter. 5. Low oil level/dirty oil. 6. Faulty spark plug. 7. Dirty fuel filter. 8. Stale or dirty fuel. 9. Water in fuel. 10. Spark plug wire loose. 11. Dirty engine air screen/fins. 12. Dirty/clogged muffler. 13. Loose or damaged wiring. 14. Carburetor out of adjustment. 15. Engine valves out of adjustment. 	<ol style="list-style-type: none"> 1. Set in "Higher Cut" position/reduce speed. 2. Adjust throttle control. 3. Clean underside of mower housing. 4. Clean/replace air filter. 5. Check oil level/change oil. 6. Clean and regap or change spark plug. 7. Replace fuel filter. 8. Drain fuel tank and refill with fresh gasoline. 9. Drain fuel tank and carburetor, refill tank with fresh gasoline and replace fuel filter. 10. Connect and tighten spark plug wire. 11. Clean engine air screen/fins. 12. Clean/replace muffler. 13. Check all wiring. 14. Contact an authorized service facility. 15. Contact an authorized service facility.
Excessive vibration	<ol style="list-style-type: none"> 1. Worn, bent or loose blade. 2. Bent blade mandrel. 3. Loose/damaged part(s). 	<ol style="list-style-type: none"> 1. Replace blade. Tighten blade bolt. 2. Replace blade mandrel. 3. Tighten loose part(s). Replace damaged parts.

TROUBLESHOOTING POINTS

PROBLEM	CAUSE	CORRECTION
Engine continues to run when operator leaves seat with attachment clutch engaged	<ol style="list-style-type: none"> 1. Faulty operator-safety presence control system. 	<ol style="list-style-type: none"> 1. Check wiring, switches and connections. If not corrected, contact an authorized service facility.
Poor cut - uneven	<ol style="list-style-type: none"> 1. Worn, bent or loose blade. 2. Mower deck not level. 3. Buildup of grass, leaves, and trash under mower. 4. Bent blade mandrel. 5. Clogged mower deck vent holes from buildup of grass, leaves, and trash around mandrels. 	<ol style="list-style-type: none"> 1. Replace blade. Tighten blade bolt. 2. Level mower deck. 3. Clean underside of mower housing. 4. Replace blade mandrel. 5. Clean around mandrels to open vent holes.
Mower blades will not rotate	<ol style="list-style-type: none"> 1. Obstruction in clutch mechanism. 2. Worn/damaged mower drive belt. 3. Frozen idler pulley. 4. Frozen blade mandrel. 	<ol style="list-style-type: none"> 1. Remove obstruction. 2. Replace mower drive belt. 3. Replace idler pulley. 4. Replace blade mandrel.
Poor grass discharge	<ol style="list-style-type: none"> 1. Engine speed too slow. 2. Travel speed too fast. 3. Wet grass. 4. Mower deck not level. 5. Low/uneven tire air pressure. 6. Worn, bent or loose blade. 7. Buildup of grass, leaves and trash under mower. 8. Mower drive belt worn. 9. Blades improperly installed. 10. Improper blades used. 11. Clogged mower deck vent holes from buildup of grass, leaves, and trash around mandrels. 	<ol style="list-style-type: none"> 1. Place throttle control in "FAST" position. 2. Shift to slower speed. 3. Allow grass to dry before mowing. 4. Level mower deck. 5. Check tires for proper air pressure. 6. Replace/sharpen blade. Tighten blade bolt. 7. Clean underside of mower housing. 8. Replace mower drive belt. 9. Reinstall blades sharp edge down. 10. Replace with blades listed in this manual. 11. Clean around mandrels to open vent holes.
Headlight(s) not working (if so equipped)	<ol style="list-style-type: none"> 1. Switch is "OFF". 2. Bulb(s) burned out. 3. Faulty light switch. 4. Loose or damaged wiring. 5. Blown fuse. 	<ol style="list-style-type: none"> 1. Turn switch "ON". 2. Replace bulb(s). 3. Check/replace light switch. 4. Check wiring and connections. 5. Replace fuse.
Battery will not charge	<ol style="list-style-type: none"> 1. Bad battery cell(s). 2. Poor cable connections. 3. Faulty regulator (if so equipped). 4. Faulty alternator. 	<ol style="list-style-type: none"> 1. Replace battery. 2. Check/clean all connections. 3. Replace regulator. 4. Replace alternator.
Engine "backfires" when turning engine "OFF"	<ol style="list-style-type: none"> 1. Engine throttle control not set at "SLOW" position for 30 seconds before stopping engine. 	<ol style="list-style-type: none"> 1. Move throttle control to "SLOW" position and allow to idle for 30 seconds before stopping engine.

TRACTOR - - MODEL NUMBER 917.252520

SCHEMATIC

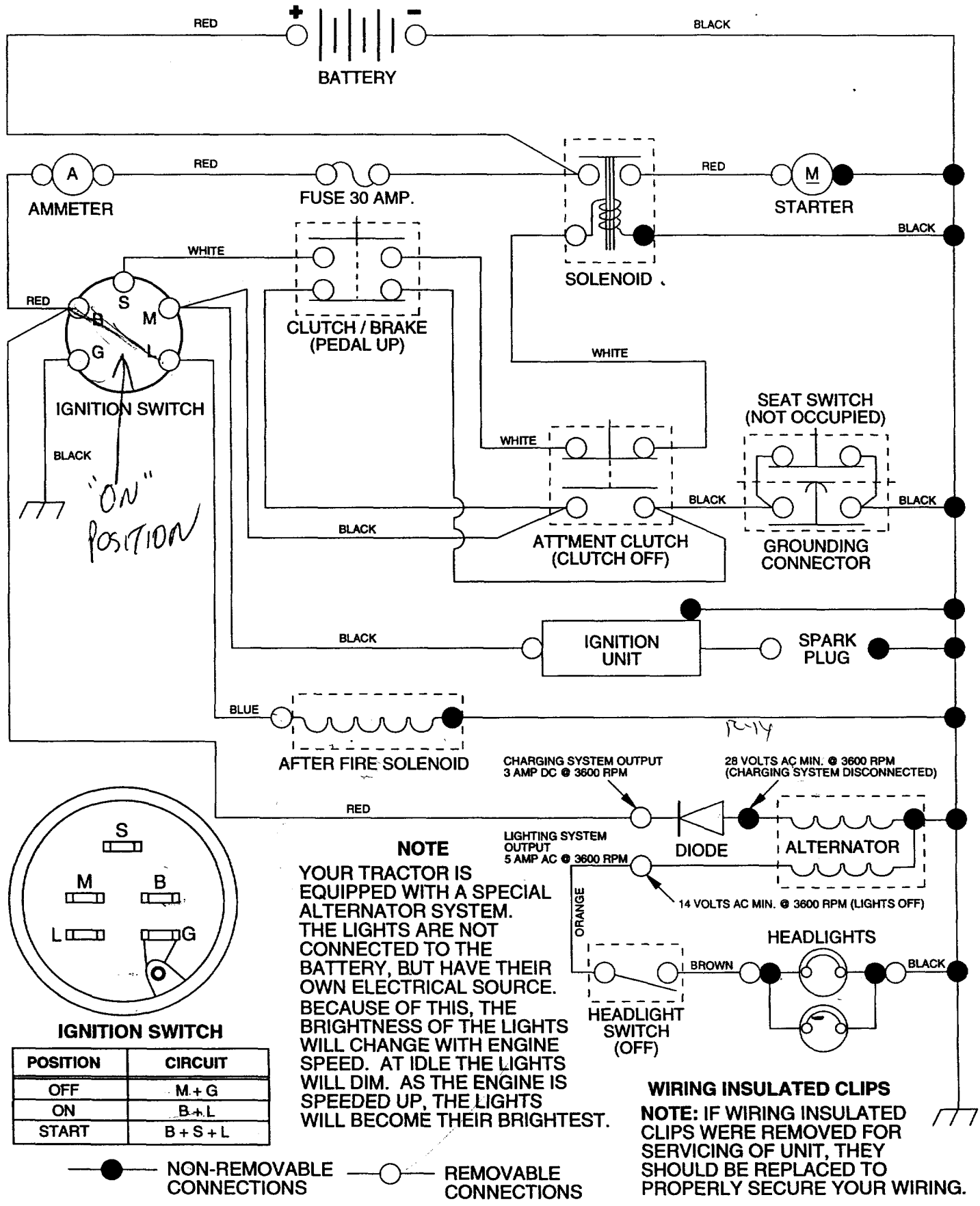

REPAIR PARTS

TRACTOR -- MODEL NUMBER 917.252520

ELECTRICAL

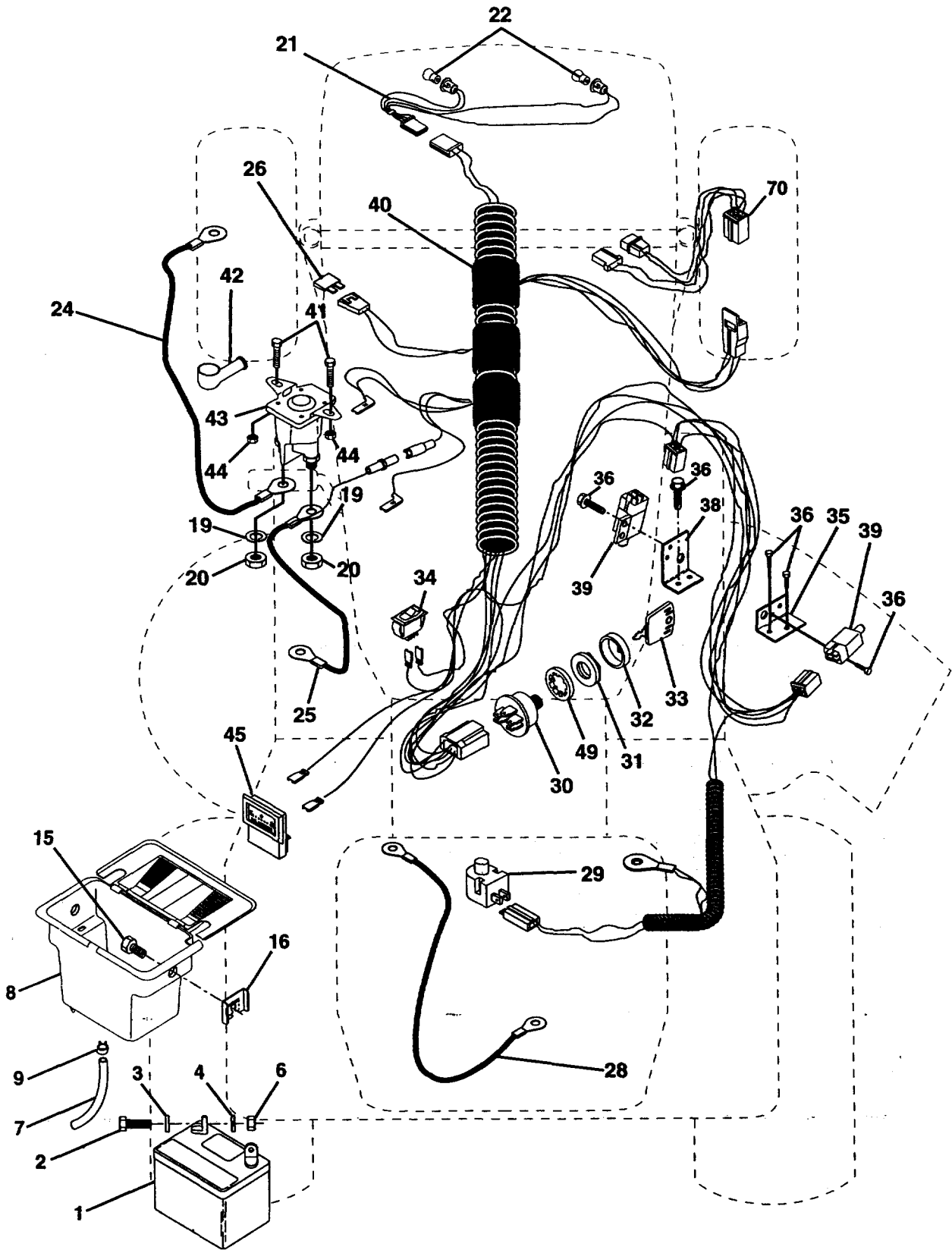

REPAIR PARTS

TRACTOR - - MODEL NUMBER 917.252520

ELECTRICAL

KEY NO.	PART NO.	DESCRIPTION
1	144925	Battery 12 Volt 25 Amp W/Acid
2	74760412	Bolt, Hex Head 1/4-20 unc x 3/4
3	STD551025	Washer
4	STD551125	Washer
6	STD541025	Nut
7	109238X	Tube, Plastic, 12"
8	144940	Case, Battery W/2 Holes W/Brty
9	109596X	Clamp, Hose
15	144935	Screw Cap Hex Nylon 3/8-16 x 1
16	145355	Nut Mylon 3/8-16 3/8
19	STD551125	Washer, Lock
20	73350400	Nut, Hex, Jam 1/4-20 UNC
21	136850	Harness, Light Socket (Includes Key # 33)
22	4152J	Bulb, Light
24	4799J	Cable, Battery, 6 Gauge, Red, 11"
25	146147	Cable, Battery, 6 Gauge, Red, W/ 16 Wir
26	108824X	Fuse, 30 Amp
28	4207J	Cable, Ground, 6 Gauge, Black, 12"
29	121305X	Switch, Plunger
30	144921	Switch, Ignition
31	140400	Nut, Ignition
32	141226	Cover, Key Switch
33	140403	Key, Ignition
34	110712X	Switch, Light
35	108236X	Bracket, Clutch Switch
36	STD601005	Screw
38	140336	Bracket, Interlock Switch
39	109553X	Switch, Interlock, Clutch, 4 Terminal
40	146057	Harness, Ignition
41	71110412	Bolt, Hex Head, Fin. 1/4-20 x 3/4
42	131563	Cover, Terminal, Red
43	145673	Solenoid
44	73800400	Nut Lock W/Insert 1/4-20 UNC
45	121433X	Ammeter Rectangular 6 Amp
49	11151000	Washer Lock Internal Tooth 5/8
70	140422	Harness Engine B&S

NOTE: All component dimensions given in U.S. inches
1 inch = 25.4 mm

REPAIR PARTS

TRACTOR -- MODEL NUMBER 917.252520

CHASSIS AND ENCLOSURES

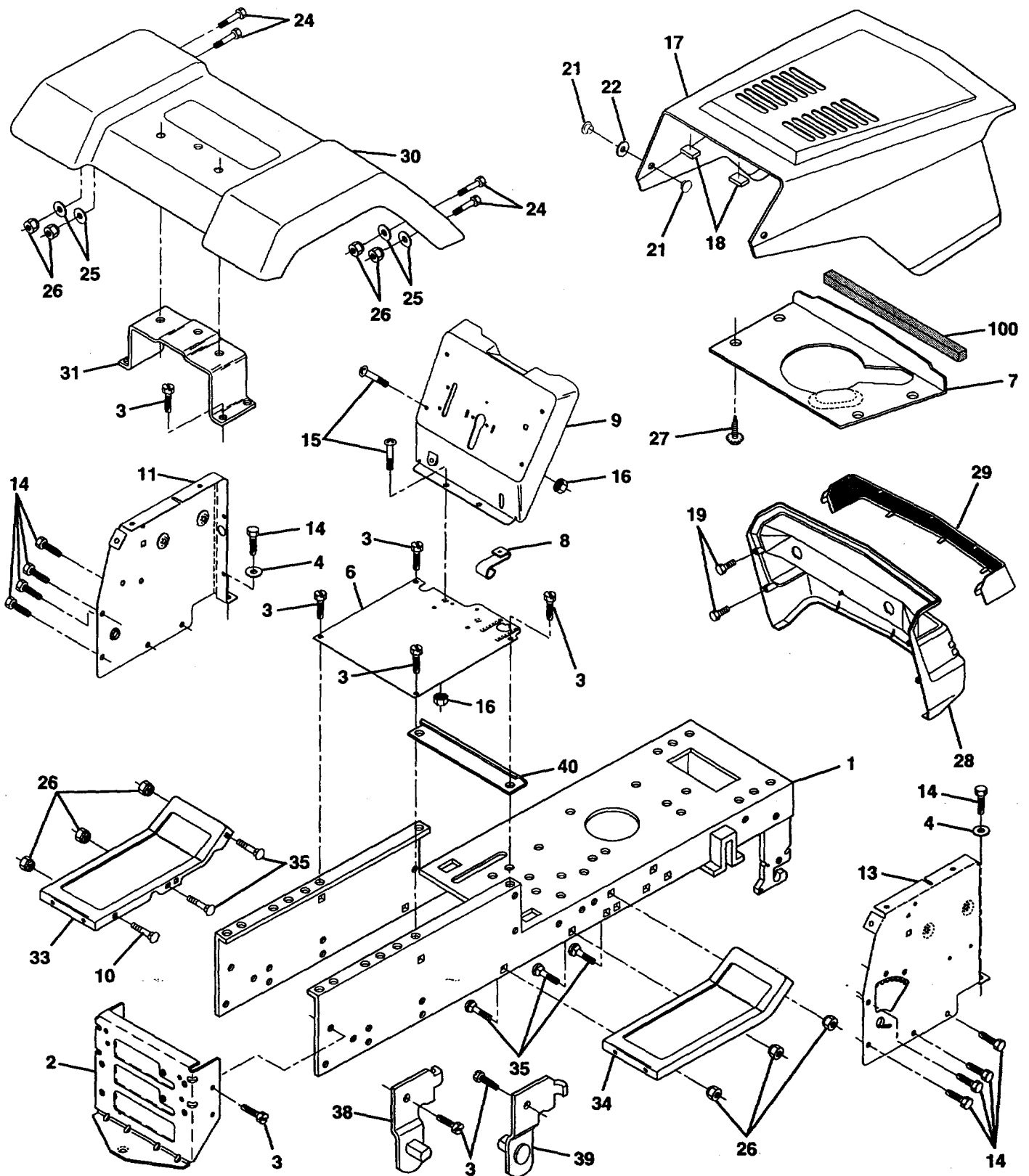

REPAIR PARTS

TRACTOR - - MODEL NUMBER 917.252520

CHASSIS AND ENCLOSURES

KEY NO.	PART NO.	DESCRIPTION
1	145501	Chassis Assembly
2	140356	Drawbar
3	17490612	Screw, Thd. Roll. 3/8-16 x 3/4
4	19131216	Washer 13/32 x 3/4 x 16 Gauge
6	145206	Saddle
7	126842X	Shield Ht Hood Kohl/Dia Engine
8	126471X	Clip Insulator .406 Mtg Hole
9	145938X001	Dash
10	72140608	Bolt, Carriage 3/8-16 x 3/4
11	135464	Panel, Dash, L.H.
13	126276X	Panel, Dash, R.H.
14	17490608	Screw Thdrol 3/8-16 x 1/2
15	74180512	Screw, Machine, Truss Head 5/16-18 UNC x 3/4
16	STD541431	Nut
17	131445X459	Hood Assembly
18	126938X	Bumper, Hood
19	17521312	Screw, Sltd. Hex Hd. w/Pl Washer
21	122933X	Rivet, Ratchet, Nylon
22	124479X	Washer, Nylon .28 x .75 x .19
24	STD523710	Bolt
25	19131312	Washer 13/32 x 13/16 x 12 Gauge
26	STD541437	Nut
27	17030814	Screw Spiderlock Hex Hd #8-7/8
28	140137	Grill
29	124029X	Lens, Headlight Bar, Clear
30	147310X459	Fender
31	139976	Bracket, Fender Support
33	145244X459	Footrest, L.H.
34	145243X459	Footrest, R.H.
35	STD533707	Bolt
38	139886	Pivot Bracket Assembly, L.H.
39	139887	Pivot Bracket Assembly, R.H.
40	139977	Spacer Fender Raised LT
100	105037X	Strip Foam 18"
--	5479J	Plug, Button

NOTE: All component dimensions given in U.S. inches
1 inch = 25.4 mm

REPAIR PARTS

TRACTOR -- MODEL NUMBER 917.252520

DRIVE

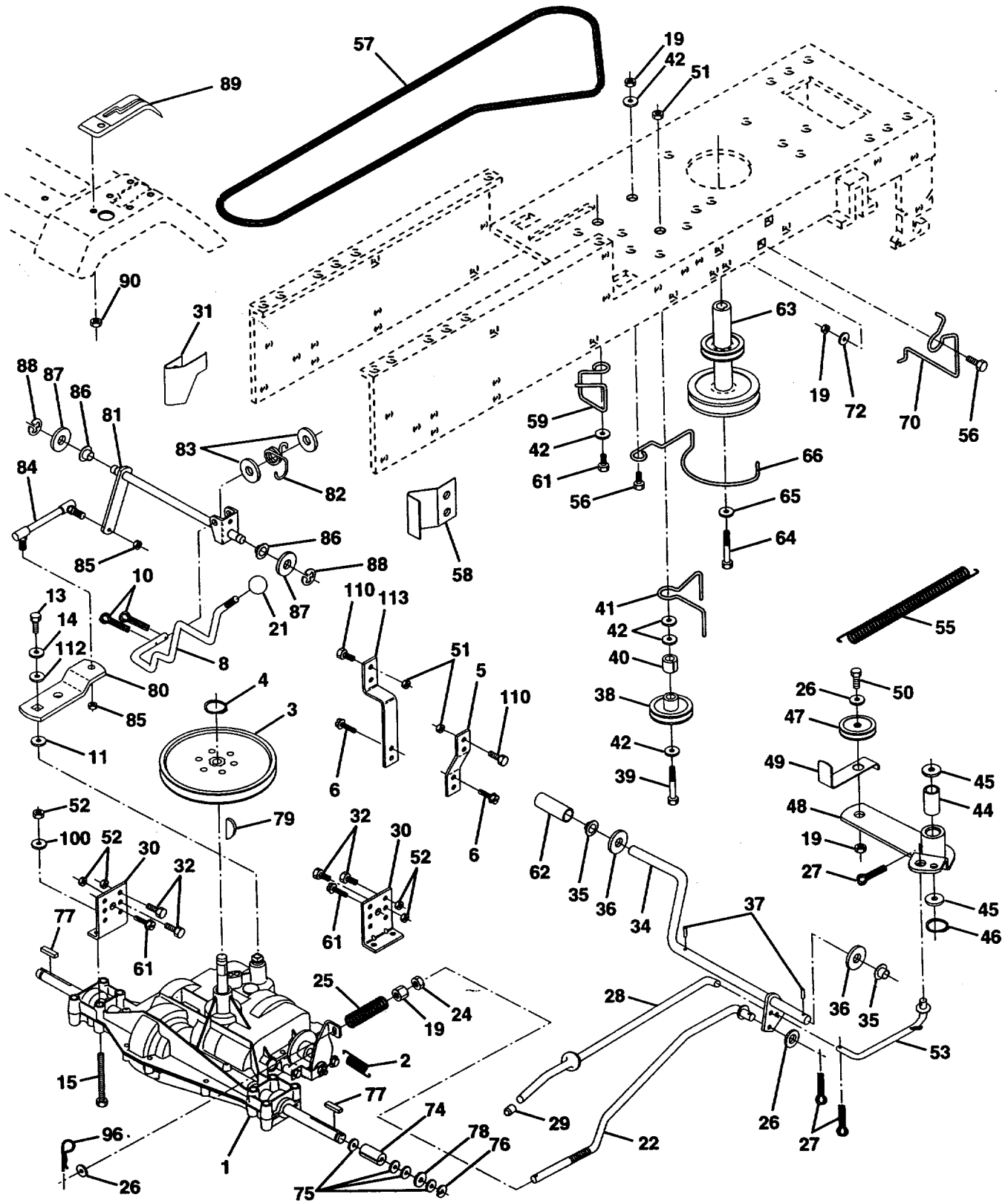

REPAIR PARTS

TRACTOR - - MODEL NUMBER 917.252520

DRIVE

KEY NO.	PART NO.	DESCRIPTION	KEY NO.	PART NO.	DESCRIPTION
1	145602	Transaxle, Peerless, 6 Speed, Model Number 930-057	49	123205X	Retainer, Belt
2	146682	Spring, Return, Brake	50	STD523715	Bolt
3	123666X	Pulley, Transaxle	51	STD541437	Nut Crown Lock 3/8-16 UNC
4	12000028	Ring, Retainer	52	STD541431	Nut Crown Lock 5/16-18 UNC
5	121520X	Strap, Torque	53	105710X	Link, Clutch
6	17490512	Screw, Thd., Roll. 5/16-18 x 3/4	55	105709X	Spring, Clutch Return
8	141003	Lever, Shift	56	STD523712	Bolt Fin Hex 3/8-16 x 1-1/4
10	76020416	Pin, Cotter	57	130801	V-Belt, Ground Drive
11	105701X	Washer, Shift Plate	58	127274X	Keeper, Belt, R.H.
12	19091210	Washer 9/32 x 3/4 x 10 Gauge	59	140312	Keeper, Belt, Center Span
13	74550412	Bolt 1/4-28 UNF W/Patch Grade 8	61	17490612	Screw, Thd., Roll. 3/8-16 x 3/4
14	STD551125	Washer	62	8883R	Cover, Pedal
15	74780544	Bolt, Hex Head 5/16-18 x 2-3/4	63	140186	Pulley, Engine
18	STD523707	Bolt	64	71170764	Bolt, Hex Head, Fin. 7/16-20 x 4 Grade 5
19	STD541437	Nut	65	STD551143	Washer
21	106933X	Knob	66	129921	Keeper, Belt, Engine, L.H.
22	130804	Rod, Brake	70	134683	Guide, Mower Drive Belt, R.H.
24	STD541237	Nut	72	19132012	Washer 13/32 x 1-1/4 x 12 Gauge
25	106888X	Spring, Brake Rod	74	137057	Spacer, Axle
26	STD551037	Washer	75	121749X	Washer 25/32 x 1-1/4 x 16 Gauge
27	STD561210	Pin	76	STD581075	E-Ring
28	145204	Rod, Parking Brake	77	123583X	Key, Square 2.0 x .1845/.1865
29	124236X	Cap, Parking Brake, Red	78	121748X	Washer 25/32 x 1-5/8 x 16 Gauge
30	130807	Bracket, Transaxle	79	2228M	Key Woodruff #9 3/16 x 3/4
31	127275X	Keeper, Belt, L.H.	80	145090	Arm, Shift
32	STD523107	Bolt	81	145092	Shaft Assembly
34	122424X	Shaft Assembly, Foot Pedal	82	123782X	Spring, Torsion
35	120183X	Bearing, Nylon	83	19171216	Washer 17/32 x 3/4 x 16 Gauge
36	STD551062	Washer	84	145643	Tie Rod
37	STD571810	Roll Pin	85	73530400	Nut, Nylock
38	123674X	Pulley, Idler, Flat	86	71208	Bushing, Pivot
39	STD523727	Bolt	87	19212016	Washer
40	4470J	Spacer, Split .395 x .59	88	12000008	E-Ring
41	109070X	Keeper, Belt, Retainer	89	139964	Console, Shift, 6 Speed, N/ignition
42	19131312	Washer 13/32 x 13/16 x 12 Gauge	90	124346X	Nut, Self-Threading, Washer Hd 1/4
44	105706X	Bearing, Nylon	96	4496H	Retainer Spring 1" Zinc Cad
45	110812X	Washer, Hardened	100	19111216	Washer 11/32 x 3/4 x 16 Ga.
46	12000039	Ring, Klip			
47	127783	Pulley, Idler, V-Groove, Plastic			
48	123789X	Bellcrank Assembly			

NOTE: All component dimensions given in U.S. inches
1 inch = 25.4 mm

REPAIR PARTS

TRACTOR - - MODEL NUMBER 917.252520

STEERING ASSEMBLY

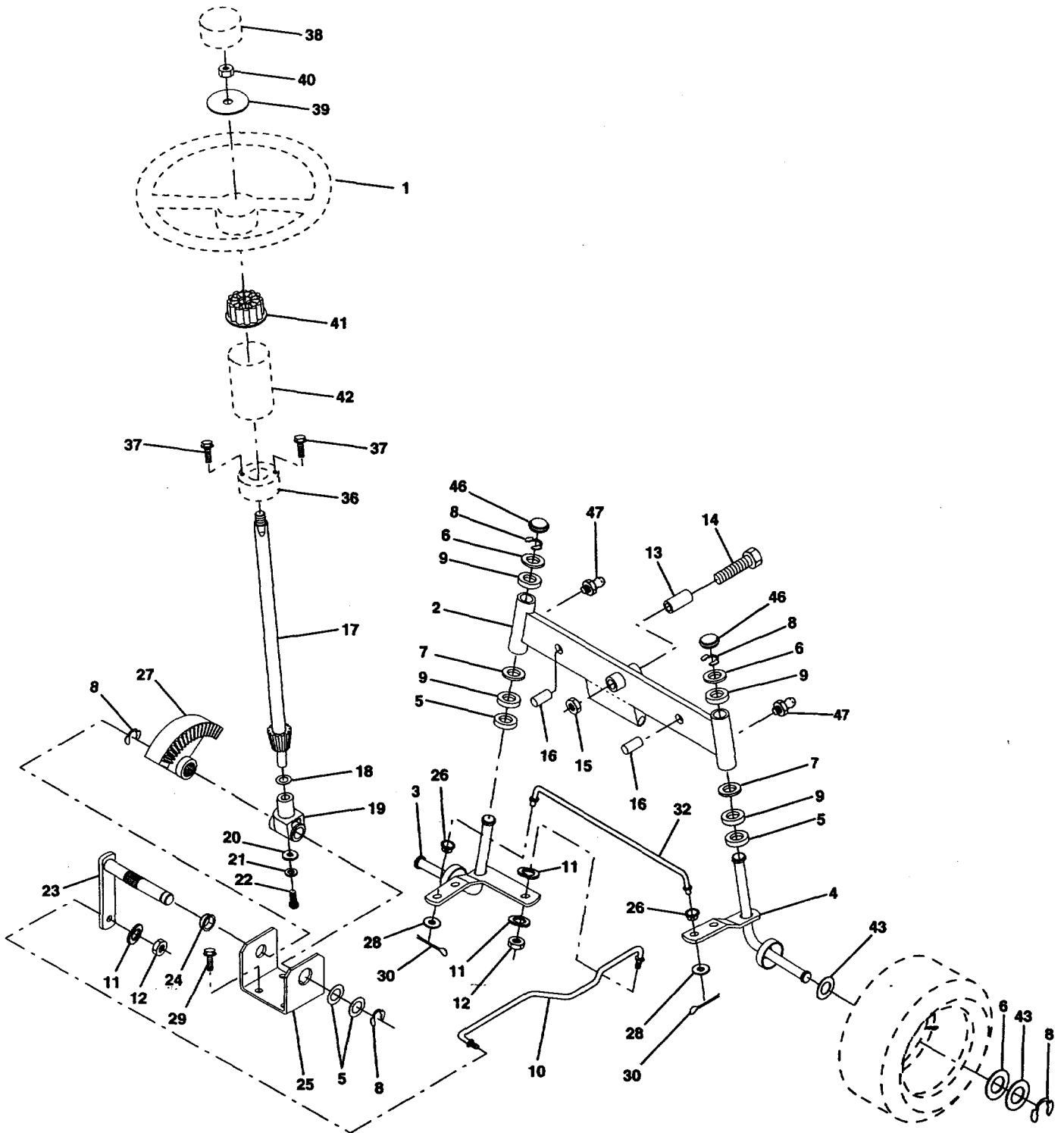

REPAIR PARTS

TRACTOR - - MODEL NUMBER 917.252520

STEERING ASSEMBLY

KEY NO.	PART NO.	DESCRIPTION
1	139768	Steering Wheel
2	142033	Front Axle Assembly
3	135227	Spindle Assembly, L.H.
4	135228	Spindle Assembly, R.H.
5	6266H	Bearing, Race, Thrust, Hardened
6	121748X	Washer 25/32 x 1-5/8 x 16 Gauge
7	19272016	Washer 27/32 x 1-1/4 x 16 Gauge
8	12000029	Ring, Klip
9	3366R	Bearing, Steering Column
10	130468	Link, Drag
11	STD551137	Washer, Lock
12	73610600	Nut, Hex, Fin. 3/8-24 UNF
13	110438X	Spacer, Bearing, Front Axle
14	74011056	Bolt, Hex Head 5/8-11 UNC x 3-1/2
15	73901000	Nut, Lock, Flange 5/8-11 UNC
16	132624	Pin, Axle 5/8 x 1.55/1.54
17	132614	Shaft Assembly, Steering
18	57079	Washer, Thrust .515 x .750 x .033
19	124035X	Support, Shaft
20	126684X	Washer, Shim 1/4 x 5/8 x .062
21	STD551125	Washer
22	71070410	Screw, Hex Socket Head 1/4-20 x 5/8
23	127501	Pittman Shaft Assembly
24	109816X	Nyliner, Snap-In
25	124036X	Bracket, Steering
26	126847X	Bushing, Link, Drag
27	136874	Gear, Sector
28	19131416	Washer 13/32 x 7/8 x 16 Gauge
29	17490612	Screw, Thd., Roll. 3/8-16 x 3/4
30	STD561210	Pin
32	130465	Rod, Tie
36	132196	Bushing, Steering
37	STD611005	Screw
38	139769	Insert, Steering Wheel
39	19133808	Washer 13/32 x 2-3/8 x 8 Gauge
40	STD541537	Gripco Nut
41	104820X	Adaptor, Steering Wheel
42	124417X	Boot, Steering Shaft
43	121749X	Washer 25/32 x 1-1/4 x 16 Gauge
46	121232X	Cap, Spindle
47	6855M	Fitting, Grease

NOTE: All component dimensions given in U.S. inches
1 inch = 25.4 mm

REPAIR PARTS

TRACTOR -- MODEL NUMBER 917.252520

SEAT ASSEMBLY

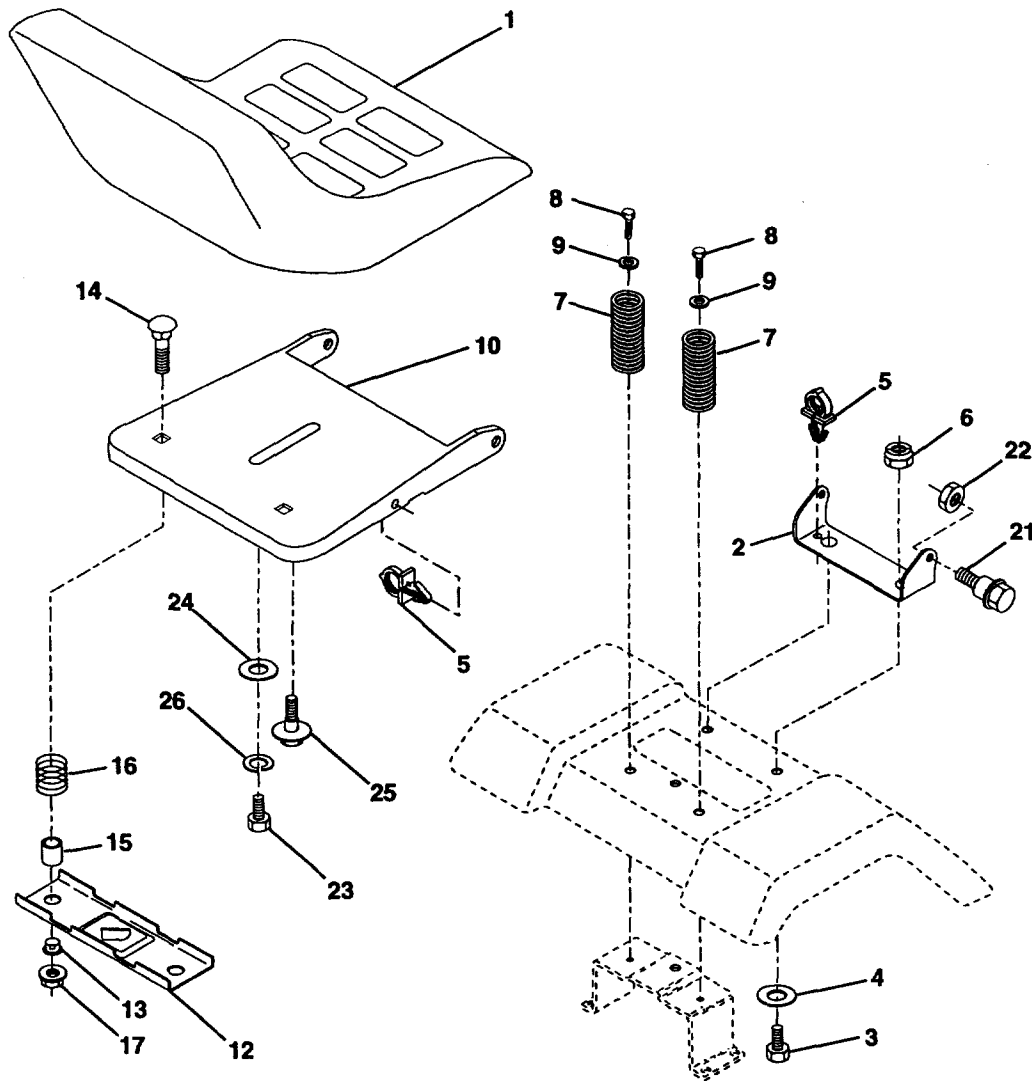

KEY NO.	PART NO.	DESCRIPTION
1	140123	Seat
2	140551	Bracket, Pivot, Seat
3	STD523710	Bolt
4	19131610	Washer 13/32 x 1 x 10 Gauge
5	145006	Clip, Push-In Hinged
6	STD541437	Nut
7	124181X	Spring, Seat
8	17490616	Screw, Thd., Roll. 3/8-16 x 1
9	19131614	Washer 13/32 x 1 x 14 Gauge
10	140552	Pan, Seat
12	121246X	Bracket, Switch Mounting
13	121248X	Bushing, Snap
14	72050411	Bolt, Carriage 1/4-20 x 1-3/8

KEY NO.	PART NO.	DESCRIPTION
15	134300	Spacer, Split .28 x .88
16	121250X	Spring
17	123976X	Locknut, Flange 1/4 Grade 5
21	139888	Bolt, Shoulder 5/16-18 UNC
22	STD541431	Nut
23	74780814	Bolt, Hex Head, Fin. 1/2-13 x 7/8 Grade 5
24	19171912	Washer 17/32 x 1-3/16 x 12 Gauge
25	127018X	Bolt, Shoulder 5/16-18 x .62
26	STD551150	Washer, Lock

NOTE: All component dimensions given in U.S. inches
1 inch = 25.4 mm

REPAIR PARTS

TRACTOR -- MODEL NUMBER 917.252520

DECALS

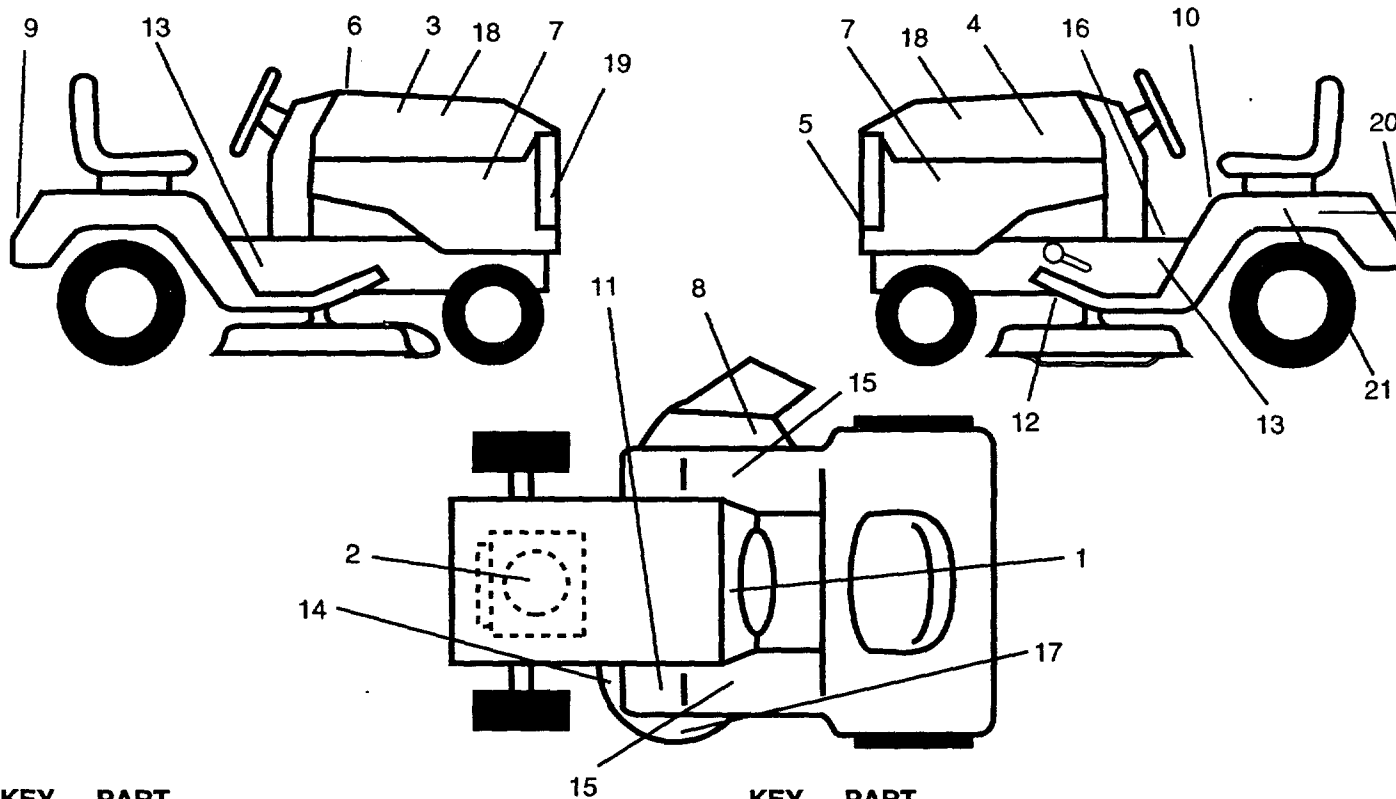

KEY NO.	PART NO.	DESCRIPTION	KEY NO.	PART NO.	DESCRIPTION
1	138955	Decal, Operating Instruction	13	131473	Decal, Chassis, 6 Speed/42"
2	272938	Decal, B&S 15HP IC/Gold OHV	14	136832	Decal, V-Belt Schematic
3	143735	Decal, Hood, R.H.	15	145245	Pad Footrest Rbr Sq Craftsman
4	143736	Decal, Hood, L.H.	16	140837	Decal, Parking Brake Saddle
5	132674	Decal, Grill, LT4000	17	133179	Decal, Mower QC System
6	133644	Decal, Customer Maintenance	18	142234	Decal, Ins. Hood 15HP OHV White
7	142235	Decal, Side Panel, IC Gold	19	131265	Decal, Lightbox, Grill
8	133178	Decal, Mower, 3 In One	20	145003	Decal Battery Dngr/Psn Eng
9	128314	Decal, Fender, Craftsman	21	145023	Decal, Battery Craftsman White
10	137537	Decal, Caution, English	--	145247	Fastener Pop In Footrest
11	4900J	Decal, Clutch/Brake, English	--	138311	Decal, Lift Handle
12	146046	Decal, V-Belt Drive Schematic	--	146831	Owner's Manual, English
			--	146832	Owner's Manual, Spanish

WHEELS & TIRES

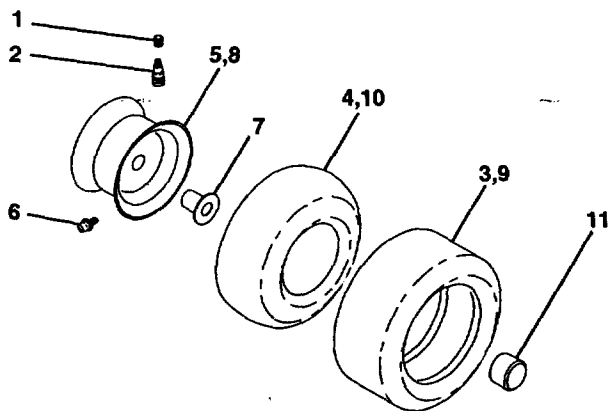

KEY NO.	PART NO.	DESCRIPTION
1	59192	Valve Cap, Tire
2	65139	Stem, Valve
3	106222X	Tire, Front
4	59904	Tube, Front Tire (Not Provided, Service Item Only)
5	106732X427	Rim, Front
6	278H	Fitting, Grease (Front Wheel Only)
7	9040H	Bearing, Flange (Front Wheel Only)
8	106108X427	Rim, Rear
9	122082X	Tire, Rear
10	7152J	Tube, Rear Tire (Not Provided, Service Item Only)
11	104757X	Cap, Axle

REPAIR PARTS

TRACTOR -- MODEL NUMBER 917.252520

ENGINE

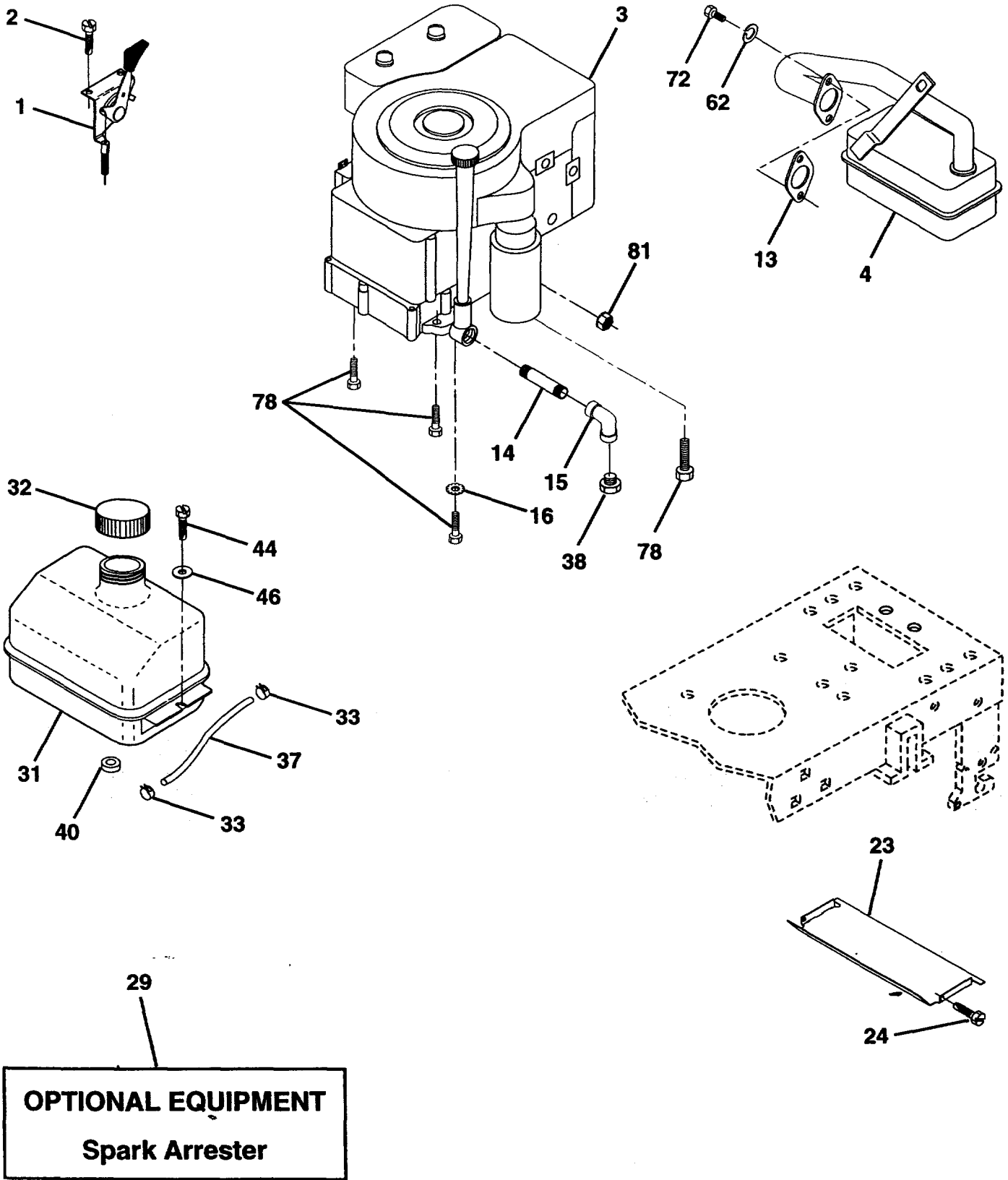

REPAIR PARTS

TRACTOR - - MODEL NUMBER 917.252520

ENGINE

KEY NO.	PART NO.	DESCRIPTION
1	132759	Control, Throttle
2	17720410	Screw, Hex Head, Thread Cutting 1/4-20 x 5/8
3	145305	Engine, B&S, 15Hp Diamond Model No. 28N707, Type No. 0162-01
4	137352	Muffler
13	125593X	Gasket, Exhaust
14	13280324	Nipple, Pipe 3/8 NPT x 3
15	13200300	Elbow, Standard 90°, 3/8-18 NPT
16	STD551237	Washer
23	128953X	Shield, Heat
24	STD601005	Screw
29	137180	Arrestor, Spark
30	127057X	Pinch Weld, Hood
31	109202X	Tank, Fuel
32	123549X	Cap Assembly, Fuel Tank, Vented
33	123487X	Clamp, Hose
37	137040	Line, Fuel
38	---	Plug, Oil Drain (Order From Engine Manufacturer)
40	124028X	Bushing, Snap, Fuel Line
44	17490412	Screw, Hex Washer Head, Thd., Roll. 1/4-20 x 3/4
46	19091416	Washer 9/32 x 7/8 x 16 Gauge
62	STD551131	Washer, Lock
72	71070512	Screw, Hex Cap Head 5/16-18 x 3/4
78	17490620	Screw, Thd., Roll. 3/8-16 x 1-1/4
81	73510400	Nut Heps Flex 1/4-20 UNC

NOTE: All component dimensions given in U.S. inches
1 inch = 25.4 mm

REPAIR PARTS

TRACTOR -- MODEL NUMBER 917.252520

MOWER LIFT

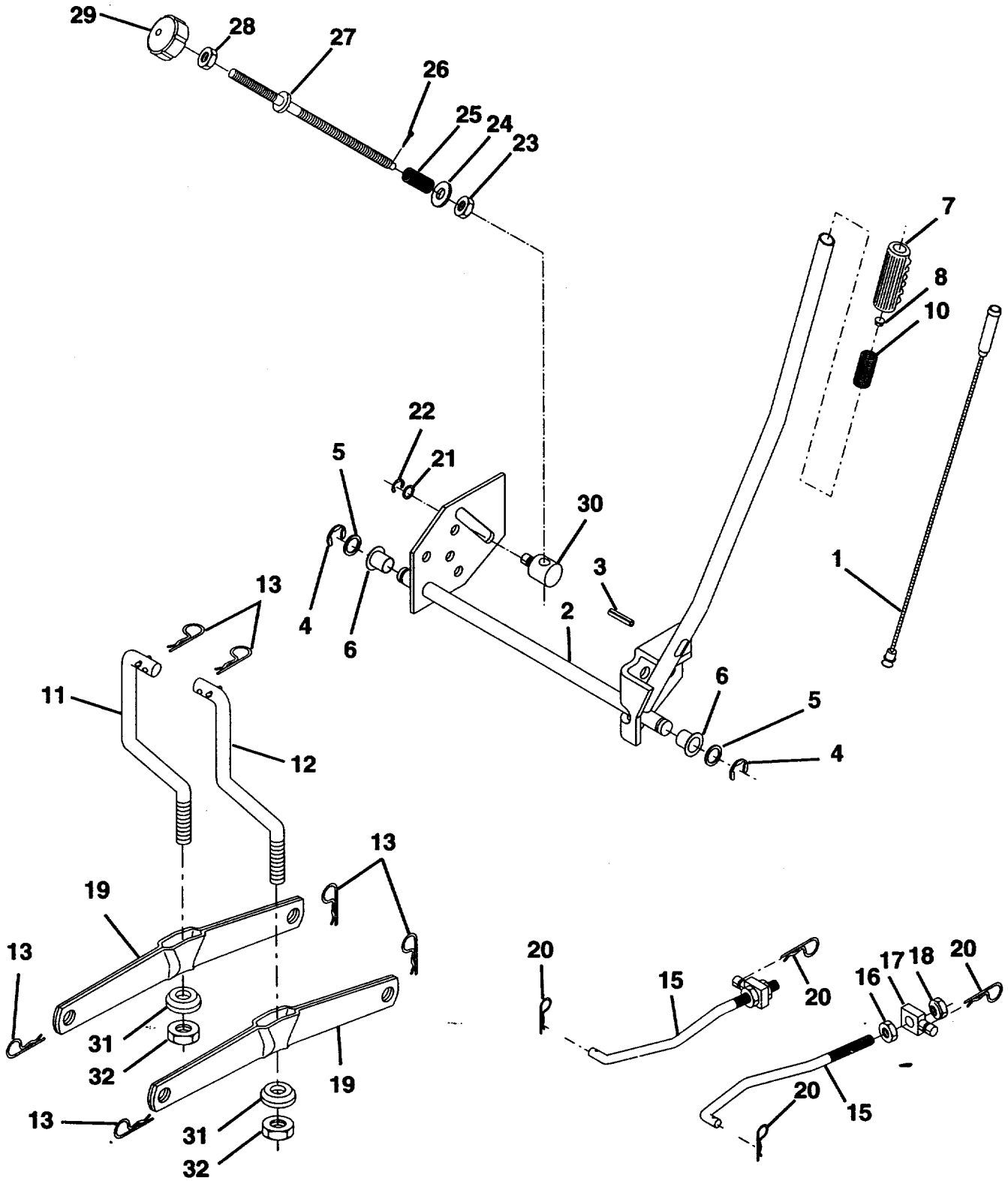

REPAIR PARTS

TRACTOR - - MODEL NUMBER 917.252520

MOWER LIFT

KEY NO.	PART NO.	DESCRIPTION
1	136973	Lift Lever Inner Wire Assembly
2	122507X	Shaft Assembly, Lift
3	105767X	Pin, Groove
4	12000002	E-Ring
5	19211621	Washer 21/32 x 1 x 21 Gauge
6	120183X	Bearing, Nylon
7	125631X	Grip, Handle, Fluted
8	122365X	Button, Plunger, Red
10	122512X	Spring
11	139865	Link, Lift, L.H.
12	139866	Link, Lift, R.H.
13	4939M	Retainer Spring
15	127218	Link, Front
16	73350800	Nut, Hex, Jam 1/2-13 UNC
17	130171	Trunnion
18	73800800	Locknut, Hex, with Washer Insert 1/2-13 UNC
19	139868	Arm, Suspension, Rear
20	3146R	Retainer Spring
21	19151216	Washer 15/32 x 3/4 x 16 Gauge
22	12000037	Ring, Klip
23	110807X	Nut, Special
24	19131016	Washer 13/32 x 5/8 x 16 Gauge
25	2876H	Spring
26	76020308	Pin, Cotter 3/32 x 1/2
27	126971X	Rod, Adjust, Lift
28	73350600	Nut, Hex, Jam 3/8-16 UNC
29	138057	Knob, Infinite Height Adjustment
30	110810X	Trunnion, Depth Stop
31	140302	Bearing, Pvt, Lift Spherical
32	73540600	Nut, Crownlock 3/8-24

NOTE: All component dimensions given in U.S. inches
1 inch = 25.4 mm

REPAIR PARTS

TRACTOR - - MODEL NUMBER 917.252520

MOWER DECK

KEY NO.	PART NO.	DESCRIPTION	KEY NO.	PART NO.	DESCRIPTION
1	144393	Mower Housing	54	133943	Washer, Hardened
2	STD533107	Bolt	55	140084	Arm, Idler
3	138017	Bracket Assembly, Sway Bar, Front	56	122052X	Spacer, Retainer
4	138440	Bracket Assembly, Sway Bar	58	140086	Spring, Torsion Brakes
5	STD624008	Retainer Spring	59	141043	Guard, TUV Idler
6	130832	Arm, Suspension, Rear	67	106932X	Knob, Round 3/8-16 UNC
8	850857	Bolt, Hex 3/8-24 x 1.25 Grade 8	68	144200	V-Belt
9	STD551137	Washer, Lock	71	142427	Rod, Clutch, Primary, with Nibs
10	140296	Washer, Hardened	72	131870	Spring, Return
11	134149	Blade, Mulching	73	127847	Arm, Clutch, Secondary
12	129895	Bearing, Ball	74	121748X	Washer 25/32 x 1-5/8 x 16 Gauge
13	137645	Shaft Assembly, Mandrel, Vented (Includes Key Number 6)	75	12000029	Ring, Klip
14	128774	Housing, Mandrel, Vented	76	128903	Bolt, Shoulder 3/8-16 UNC x 1.44
15	110485X	Bearing, Ball, Mandrel	77	127845	Keeper, Spring
16	140329	Stripper, Vented Mower Deck	78	140334	Arm, Clutch, Primary
17	72110610	Bolt, Carriage 3/8-16 x 1-1/4	79	127498	Bushing, Large, Brass
18	72140505	Bolt, Carriage 5/16-18 x 5/8	80	128759	Spring, Mower Clutch
19	132827	Bolt, Shoulder	81	73350600	Nut, Hex Jam 3/8-16 Unc
20	136888	Baffle, Vortex	82	142028	Trunnion, Adj.
21	STD541431	Nut Crownlock 5/16-18 UNC	83	120958X	Washer Sintered
22	134753	Stiffener Bracket	84	144394	Keeper Belt Idler Fixed
23	131267	Bracket, Deflector	85	72140620	Bolt Carriage 3/8-16 x 2-1/2 Gr. 5
24	105304X	Cap, Sleeve	92	STD541437	Nut
25	123713X	Spring, Torsion, Deflector	101	136420	Mulcher Cover
26	110452X	Nut, Push	102	71161010	Screw
27	130968	Shield, Deflector	103	19061216	Washer #10
28	19111016	Washer 11/32 x 5/8 x 16 Gauge	104	STD551110	Washer, Lock
29	131491	Rod, Hinge	105	130758	Latch Assembly, Bagger
30	138776	Screw Thdrol Hex Head Zinc Mwr	106	2029J	Nut, Weld
31	129963	Washer, Spacer	111	140353	Bracket, Gauge, Wheel L.H.
32	129861	Pulley, Mandrel	112	132262	Bracket, Gauge, Wheel R.H.
33	137266	Nut, Toplock, Flanged	113	17490512	Screw Thdrol 5/16-18 x 3/4
34	STD533717	Bolt	114	73510500	Nut, Hex, Keps 5/16-18 UNC
35	133835	Fastner, Christmas Tree	115	72110504	Bolt, Carriage 5/16 UNC x 1/2
36	131494	Pulley, Idler, Flat	116	137644	Bolt, Shoulder
37	19131316	Washer 13/32 x 13/16 x 16 Gauge	117	133957	Wheel, Gauge
40	STD541437	Nut Crownlock 3/8-16 UNC	118	73930600	Nut, Centerlock 3/8-16
41	133551	Rod, Pivot, with Nibs	119	19121414	Washer 3/8 x 7/8 x 14 Gauge
43	140083	Rod, Clutch, Secondary, with Nibs	121	143723	Bracket
44	140088	Guard, Mandrel, L.H.	--	130794	Mandrel Assembly (Includes Key Numbers 8-10, 12-15, 31 and 32)
45	STD624003	Retainer	--	145411	Mower Deck, Complete (Standard Deck, Order Separately Mulcher Plate and Gauge Wheel Components, Key Nos. 101-106 and 111-121)
46	137729	Screw, Thd. Roll 1/4-20 x 5/8			
48	133944	Washer, Hardened			
49	133940	Roller Assembly, Cam Follower			
50	131340	Bolt, Shoulder #10-24 Grade 5			
51	STD541410	Locknut			
52	139888	Bolt, Shoulder 5/16-18 UNC			
53	131845	Arm Assembly, Pad, Brake			

NOTE: All component dimensions given in U.S. inches
1 inch = 25.4 mm

REPAIR PARTS

TRACTOR -- MODEL NUMBER 917.252520

PEERLESS TRANSAXLE - MODEL NUMBER 930-057

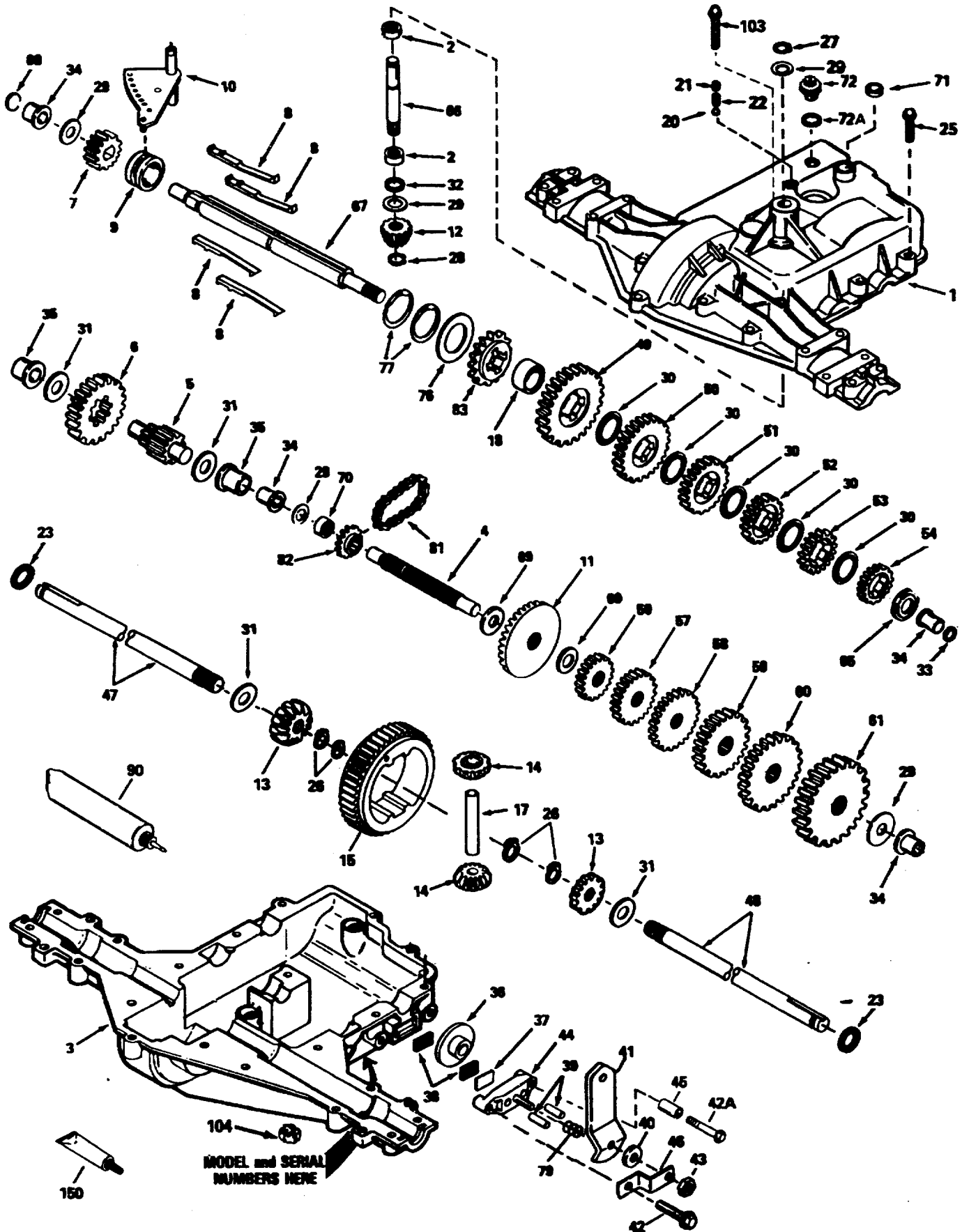

REPAIR PARTS

TRACTOR - - MODEL NUMBER 917.252520

PEERLESS TRANSAXLE - MODEL NUMBER 930-057

REF PART NO. NO.	DESCRIPTION	REF PART NO. NO.	DESCRIPTION		
1	772108A	Transaxle Cover	45	786066	Spacer
2	780086	Needle Bearing	46	786086	Brake Lever Bracket
3	770102A	Transaxle Case	47	774690	Axle, 11-15/16" Long
4	776260	Countershaft	48	774691	Axle, 16-1/2" Long
5	776219B	Output Shaft & Pinion	49	778215	Spur Gear, 37 Teeth, Steel
6	778139	Output Gear, 35 Teeth	50	778125	Spur Gear, 35 Teeth
7	778136	Spur Gear, 15 Teeth, Steel	51	778124A	Spur Gear, 30 Teeth
8	792136A	Shift Key	52	778123A	Spur Gear, 25 Teeth
9	784352	Shift Collar	53	778122A	Spur Gear, 22 Teeth
10	784355	Shift Rod & Fork	54	778273	Spur Gear, 19 Teeth, Steel
11	778229	Bevel Gear, 42 Teeth	56	778230	Spur Gear, 12 Teeth, Steel
12	778113A	Input Bevel Pinion	57	778151	Spur Gear, 15 Teeth
13	778221	Bevel Gear, 16 Teeth	58	778126A	Spur Gear, 20 Teeth
14	778068	Differential Pinion	59	778127A	Spur Gear, 25 Teeth
15	778260	Ring Gear	60	778128A	Spur Gear, 28 Teeth
17	786139	Drive Pin	61	778163	Spur Gear, 31 Teeth
18	786102	Spacer	65	780109	Washer
20	792077	Steel Ball, 5/16" Diameter	66	776135	Input Shaft
21	792078	Set Screw 3/8-16 x 3/8	67	776315A	Shifter and Brake Shaft
22	792079	Spring	68	786116	Disk
23	788061	Seal Ring	69	780051	Washer
25	792073	Screw 1/4-20 x 1-1/4	70	786118	Spacer
26	792125	Retaining Ring, Package of 2	71	788069	Square Cut Ring
27	792035	Retaining Ring	72	792165	Threaded Plug 9/16-18
28	788040	Retaining Ring	72A	788091	"O" Ring
29	780072	Washer	76	780090	Washer
30	780108	Washer	77	788078A	Inverted Retaining Ring, Package of 2
31	780001	Washer	79	792144	Spring
32	792001	"O" Ring	81	786081	Roller Chain, Number 41 Chain, 24 Links
33	788051	Square Cut Ring	82	786082	Sprocket, 9 Teeth
34	780105A	Flanged Bushing	83	786123	Reverse Sprocket, 18 Teeth
35	780118A	Flanged Bushing	90	788067B	Grease, Bentonite, 32 Ounce Bottle
36	790003	Brake Disk	103	792166	Screw 1/4-20 x 2
37	790007	Brake Pad Plate	104	792167	Locknut 1/4-20
38	799021	Brake Pad, Package of 2	150	510334	Gasket Eliminator, Loctite #515
39	786026	Dowel Pin			
40	792076A	Washer			
41	790079	Brake Lever			
42	792073	Screw 1/4-20 x 1-1/4			
42A	792085A	Screw 1/4-20 x 2-1/4			
43	792075	Locknut 5/16-24			
44	790025	Brake Pad Holder			

Parts must be ordered from Tecumseh Products Co.

NOTE: All component dimensions given in U.S. inches
1 inch = 25.4 mm

REPAIR PARTS

TRACTOR -- MODEL NUMBER 917.252520

BRIGGS & STRATTON ENGINE - MODEL NUMBER 28N707, TYPE NUMBER 0162-01

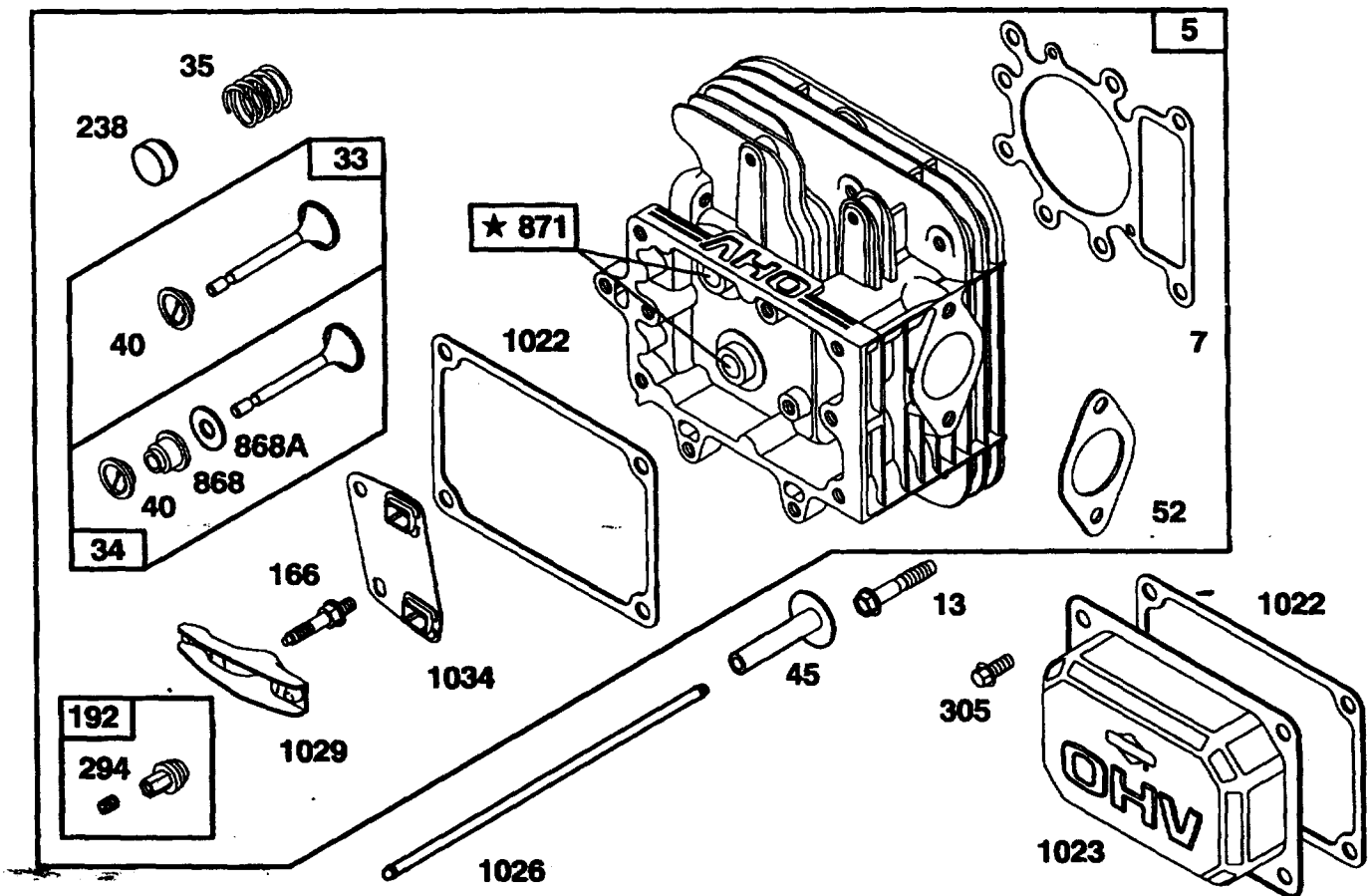
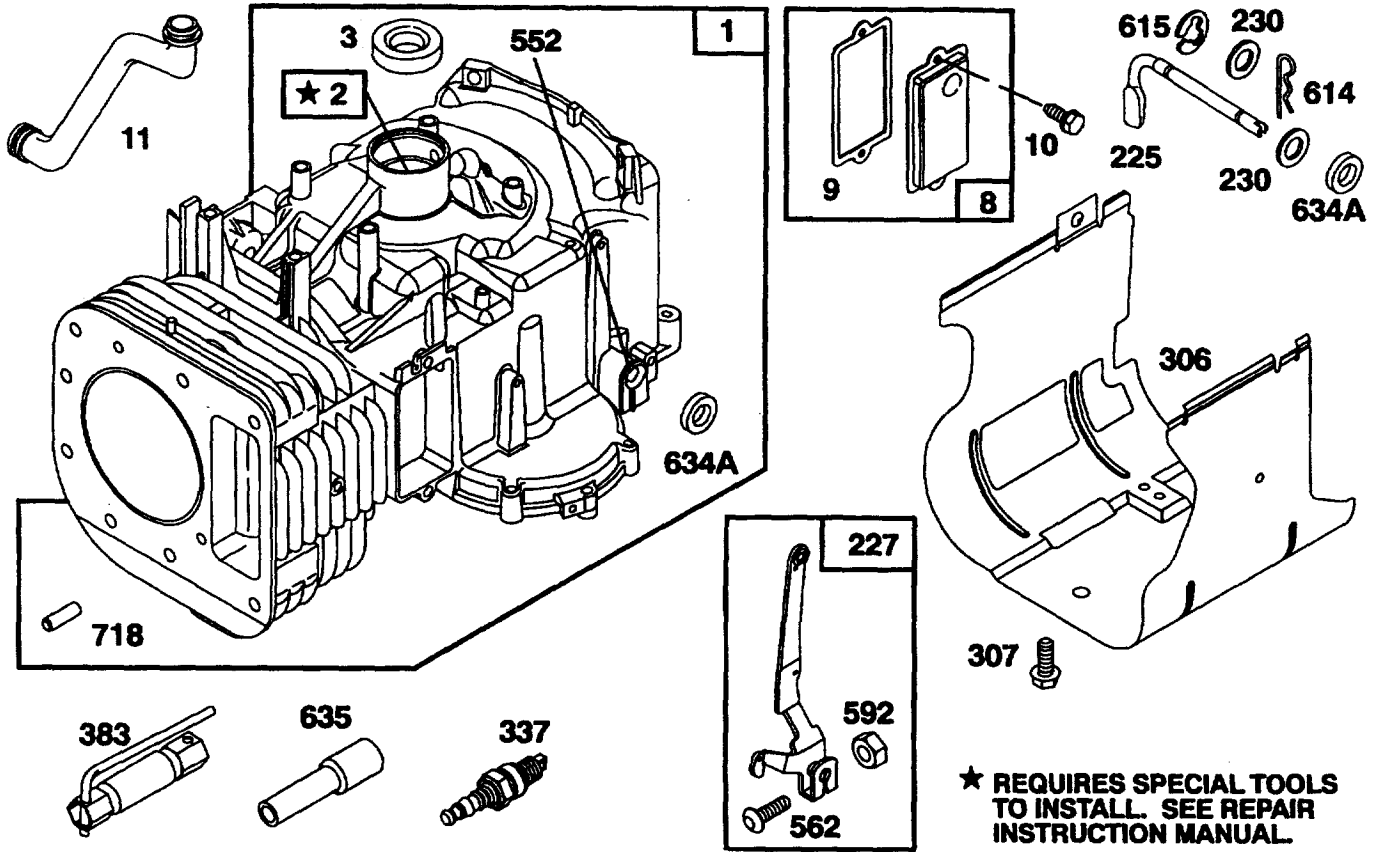

REPAIR PARTS

TRACTOR - - MODEL NUMBER 917.252520

BRIGGS & STRATTON ENGINE - MODEL NUMBER 28N707, TYPE NUMBER 0162-01

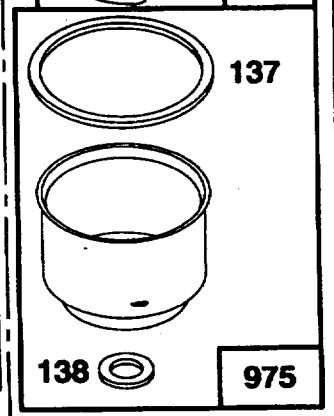
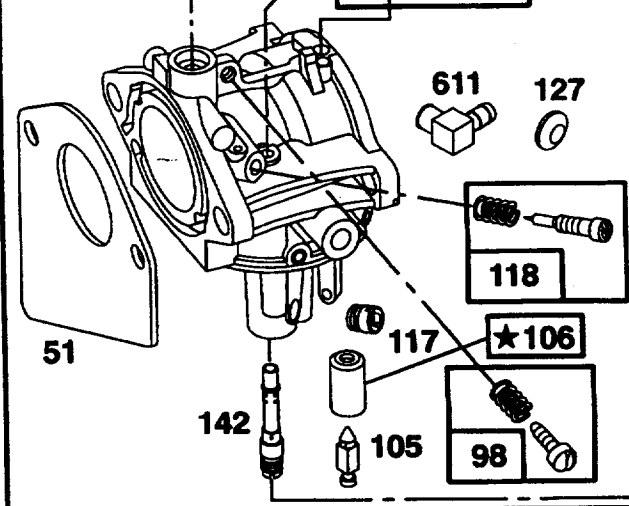
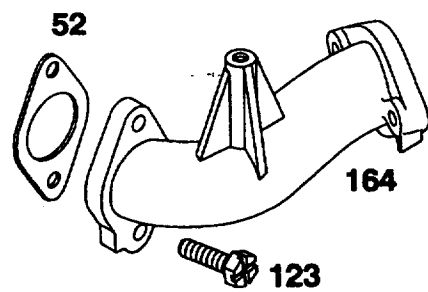
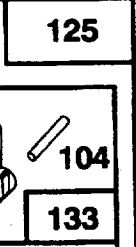
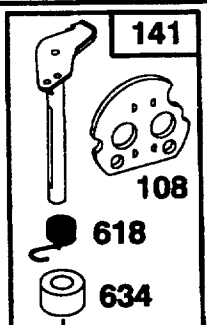
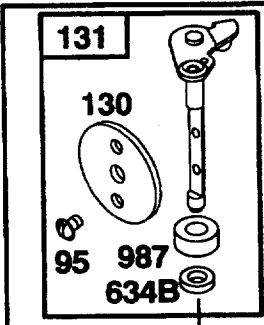
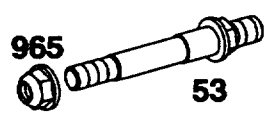
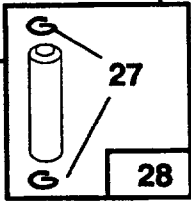
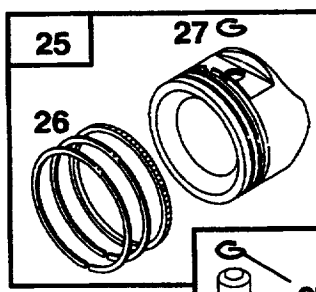
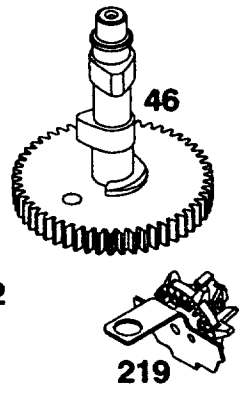
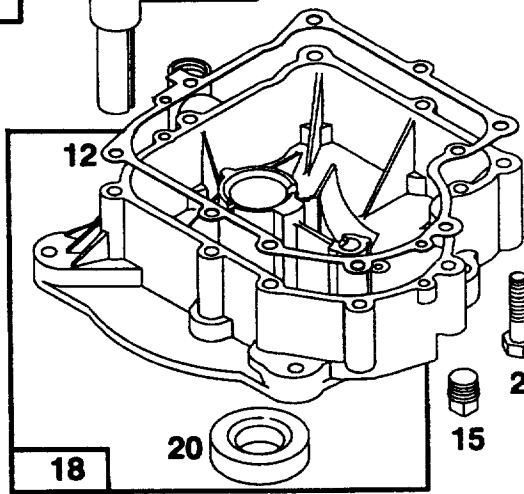
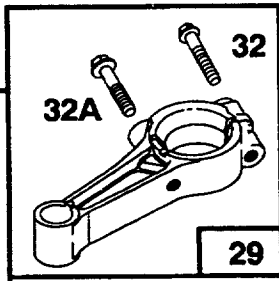
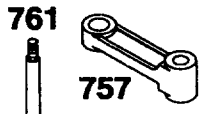
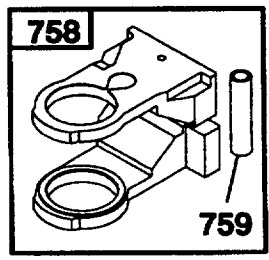
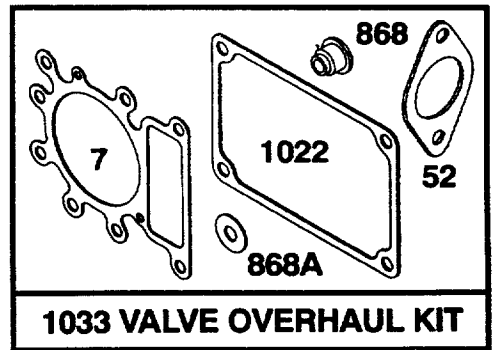
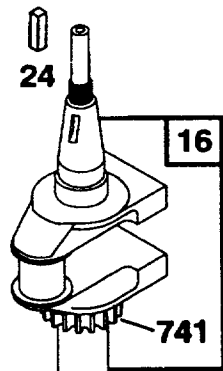
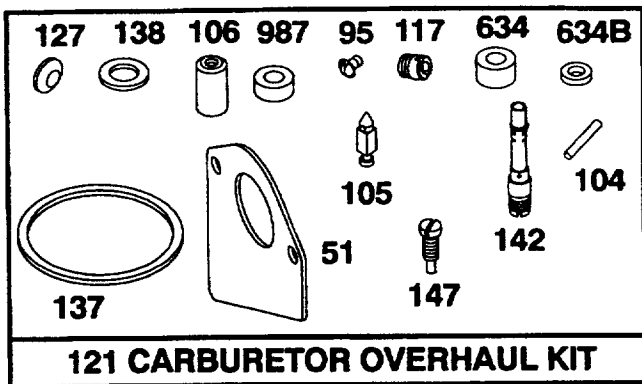

★ REQUIRES SPECIAL TOOLS TO INSTALL. SEE REPAIR INSTRUCTION MANUAL.

REPAIR PARTS

TRACTOR - - MODEL NUMBER 917.252520

BRIGGS & STRATTON ENGINE - MODEL NUMBER 28N707, TYPE NUMBER 0162-01

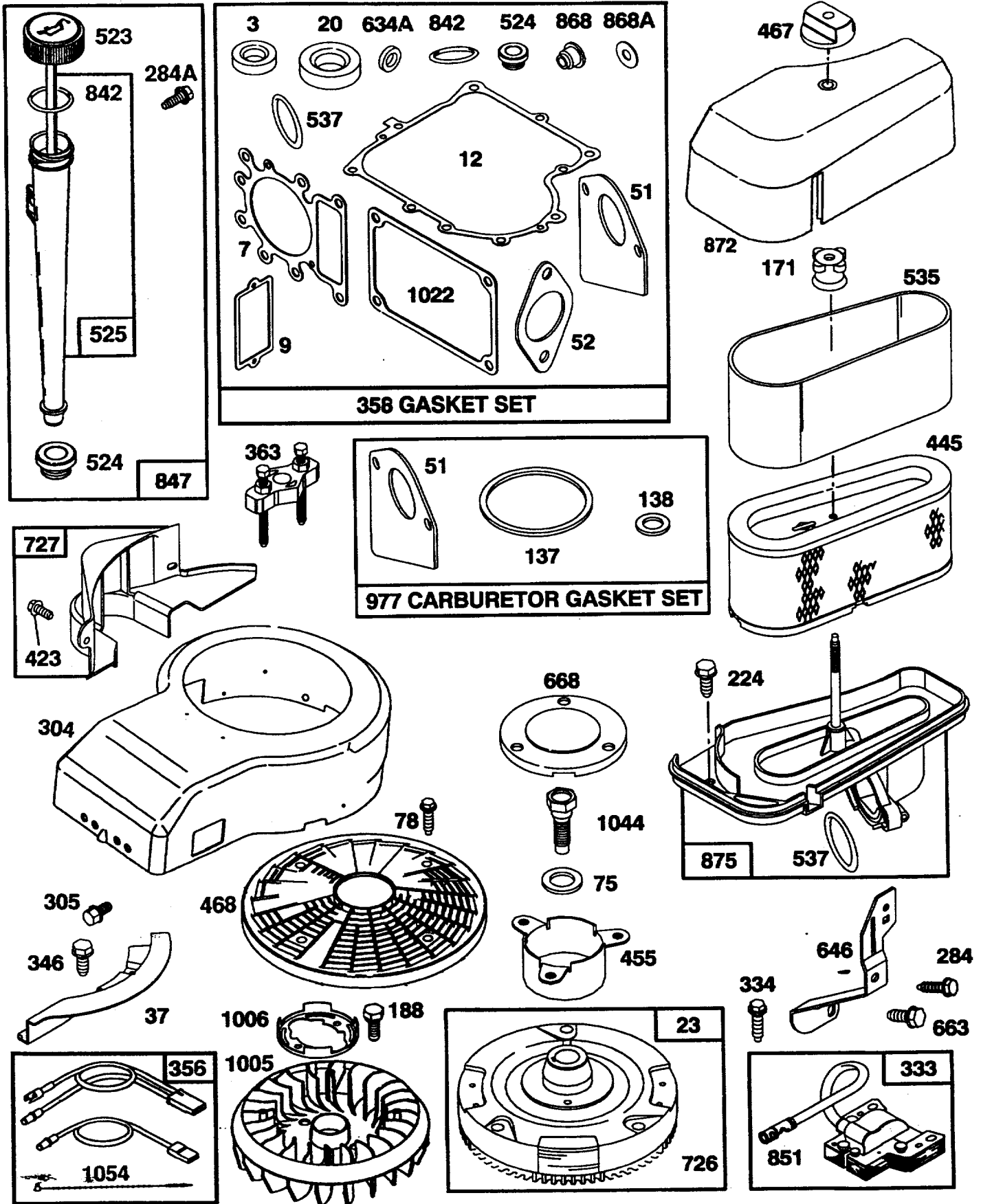

REPAIR PARTS

TRACTOR - - MODEL NUMBER 917.252520

BRIGGS & STRATTON ENGINE - MODEL NUMBER 28N707, TYPE NUMBER 0162-01

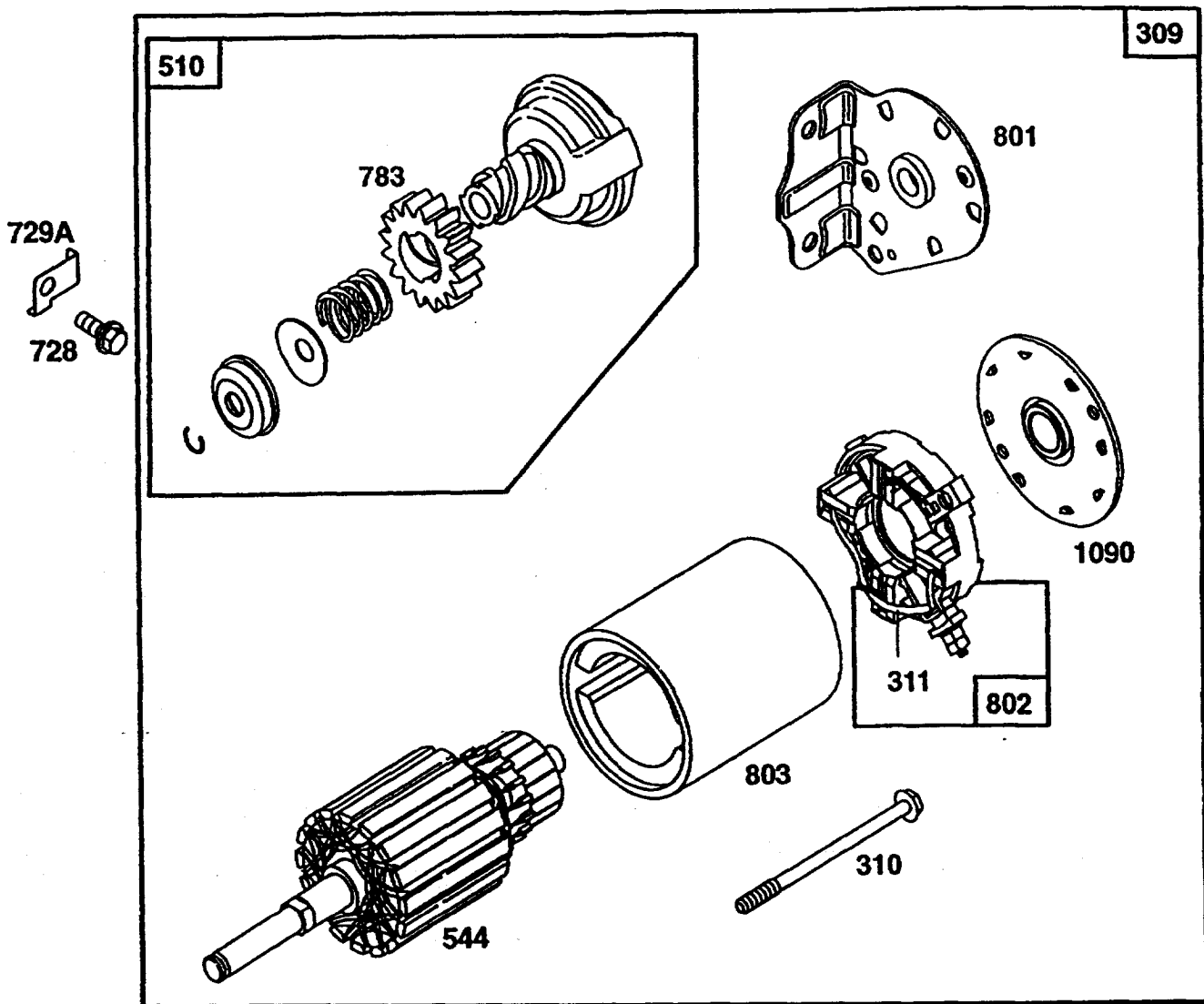
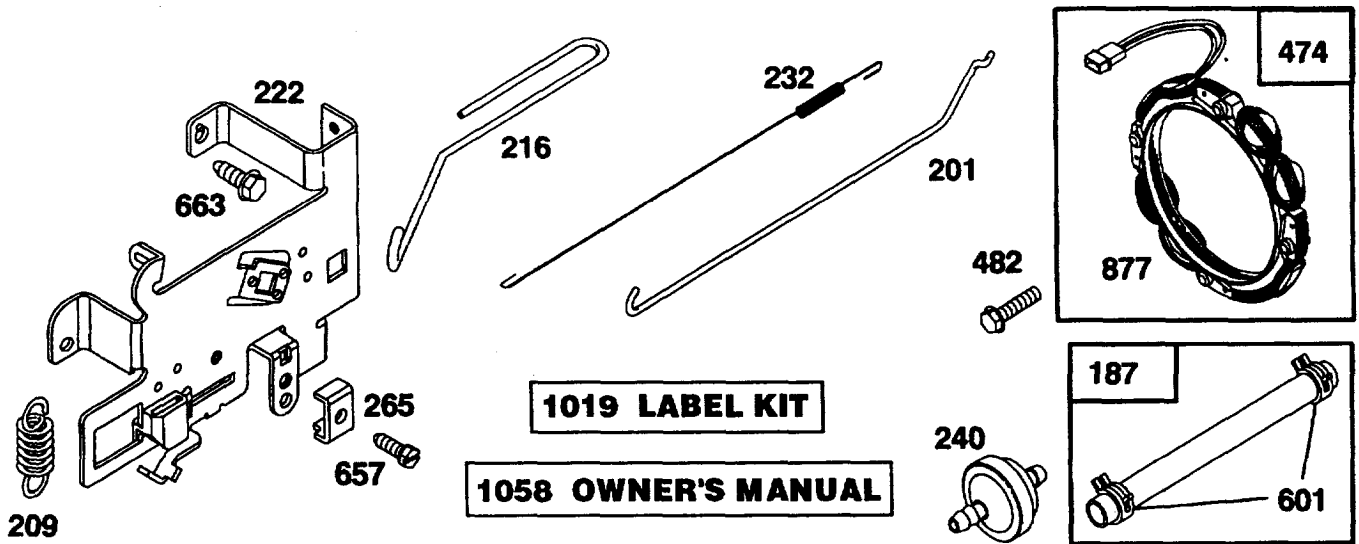

REPAIR PARTS

TRACTOR - - MODEL NUMBER 917.252520

BRIGGS & STRATTON ENGINE - MODEL NUMBER 28N707, TYPE NUMBER 0162-01

KEY PART NO.	NO.	DESCRIPTION	KEY PART NO.	NO.	DESCRIPTION
1	496412	Cylinder Assembly	95	94098	** Screw, Throttle
2	399265	Bearing, Cylinder	98	495800	Screw, Idle Speed
3	391086	* Seal, Oil	104	231789	** Pin, Float Hinge
5	495858	Head, Cylinder	105	231855	** Valve Float
7	272614	*** Gasket, Cylinder Head	106	231854	** Seat, Inlet Valve
8	495735	Breather Assembly	108	224540	Valve, Choke
9	27803	* Gasket, Valve Cover	117	231858	** Jet, Needle Valve
10	94621	Screw, Sems	118	495932	Valve, Needle
11	281246	Tube, Breather	121	497535	Carburetor Overhaul Kit
12	271916	* Gasket, Crankcase Cover, .015"	123	94616	Screw, Elbow Mounting
	271997	* Gasket, Crankcase Cover, .005"	125	495935	Carburetor Assembly
	271996	* Gasket, Crankcase Cover, .009"	127	- - -	** Plug, Welch (Sold in Kit Only)
13	94728	Screw, Cylinder Head	130	224539	Valve, Throttle
15	94239	Plug, Oil Drain	131	494379	Shaft and Lever, Throttle
16	495162	Crankshaft	133	494381	Float, Carburetor
	94196	Timing Gear Key	137	281165	**** Gasket, Float Bowl
18	494238	Base, Engine	138	281164	**** Washer, Bowl
20	291675	* Seal, Oil	141	495931	Shaft and Lever, Choke
22	94624	Screw, Sems, Base Mounting	142	231859	** Nozzle, Carburetor
23	492326	Flywheel and Ring Gear Assembly, Magneto	147	497472	** Pilot, Jet
24	222698	Key, Flywheel	164	214053	Elbow, Carburetor
25	495860	Piston Assembly, Standard Size	166	94555	Stud, Rocker Arm
	495977	Piston Assembly, .010" Oversize	171	281051	Nut, Air Cleaner Mounting
	495978	Piston Assembly, .020" Oversize	187	393815	Line, Fuel (11" Long, Cut to Suit)
	495979	Piston Assembly, .030" Oversize	188	94627	Screw, Sems
26	495854	Ring Set, Piston, Standard Size	192	492160	Screw Assembly, Rocker Arm
	495852	Ring Set, Piston, .010" Oversize	201	262767	Link, Governor
	495851	Ring Set, Piston, .020" Oversize	209	260695	Spring, Governor
	495855	Ring Set, Piston, .030" Oversize	216	262766	Link, Choke
27	260924	Lock, Piston Pin	219	490815	Gear, Governor
28	299691	Pin Assy., Piston, Standard Size	222	495611	Plate, Governor Control
	391286	Pin Assy., Piston, .005" Oversize	224	94729	Screw, Sems, Air Cleaner
29	494504	Rod Assembly, Connecting	225	231058	Crank, Governor
	495490	Rod Assembly, Connecting, .020" Undersize Crankpin Bore	227	493935	Lever Assembly, Governor
32	94695	Screw, Hex Washer Head, 1-5/7/64	230	94742	Washer, Governor Crank
32A	94648	Screw, Hex Washer Head, 1-5/8	232	262785	Spring, Governor Link
33	495856	Valve, Exhaust	238	262836	Cap, Valve
34	495857	Valve, Intake	240	394358	Filter, Fuel (In Fuel Line)
35	262811	Spring, Valve	265	221535	Clamp, Casing
37	224502	Guard, Flywheel	284	94704	Screw, Hex Head
40	224641	Retainer, Valve Spring			* Included in Gasket Set (495993)
45	262411	Tappet, Valve			** Included in Carburetor Kit (497535)
46	494433	Gear, Cam			*** Included in both Gasket Set (495993) and Valve Overhaul Kit (495992)
51	272465	**** Gasket, Carburetor (Carburetor to Elbow) (Also Included in Gasket Set, Part Number 495993)			**** Included in Gasket Set (495993), Carburetor Kit (497535) and Carburetor Gasket Set (494385)
52	272569	*** Gasket, Carburetor (Elbow to Cylinder)			
53	94637	Stud, Carburetor Mounting			
75	224061	Washer, Spring			
78	94832	Screw, Pan Head			

NOTE: All component dimensions given in U.S. inches
1 inch = 25.4 mm

REPAIR PARTS

TRACTOR - - MODEL NUMBER 917.252520

BRIGGS & STRATTON ENGINE - MODEL NUMBER 28N707, TYPE NUMBER 0162-01

KEY PART NO. NO.	DESCRIPTION	KEY PART NO. NO.	DESCRIPTION
284A 94073	Screw, Hex Head	729A 225170	Retainer, Wire
294 810068	Screw, Set	741 262932	Gear, Timing
304 496280	Housing, Blower	757 213998	Link, Counterweight
305 94729	Screw, Hex, Head, Blower Housing Mounting	758 399891	Counterweight Assembly
306 224696	Shield, Cylinder	759 298909	Pin, Counterweight
307 94623	Screw, Cylinder Shield	761 94593	Screw, Counterweight
309 497595	Motor, Starter	783 280104	Gear, Starter
310 497602	Bolt, Thru	801 394856	Cap, Drive
311 497608	Brush Set	802 497605	Cap, End
333 495859	Armature, Magneto	803 497604	Housing, Starter
334 93381	Screw, Sems, Armature Mounting	842 270920	* Seal, Oil Filler Cap
337 491055	Plug, Spark	847 496415	Fill Group, Oil
346 93705	Screw, Hex Head	851 224110	Terminal, Ignition Cable
356 496070	Wire Assembly	868 494435	*** Seal Assembly, Valve
358 495993	Gasket Set	868A 272610	*** Gasket, Valve
363 19203	Puller, Flywheel	871 262835	Bushing, Guide (Intake & Exhaust)
383 89838	Wrench, Spark Plug	872 281361	Cover, Air Cleaner
423 94073	Screw, Sems	875 495862	Body, Air Cleaner
445 493909	Cartridge, Air Cleaner	877 393456	Diode and Connector Assembly
455 222561	Cup, Screen Mounting	947 495739	Solenoid
467 493903	Knob, Air Cleaner	965 94108	Nut, Hex
468 494439	Screen, Flush Rotating	975 495933	Bowl Assembly, Carburetor
474 393474	Stator, Alternator	977 494385	Carburetor Gasket Set
482 93621	Screw, Sems	987 281166	** Seal, Throttle Shaft
510 497606	Drive, Starter	1005 281400	Fan, Flywheel
523 495230	Cap and Dipstick, Oil Filler	1006 224413	Retainer, Fan
524 68838	* Seal, Filler Tube	1019 496758	Label Kit
525 496113	Tube, Oil Filler	1022 272475	*** Gasket, Cover
535 272403	Element, Filter	1023 224552	Cover, Rocker Arm
537 281106	* O-Ring, Air Cleaner	1026 494432	Rod, Push, Intake
544 497603	Armature, Starter	495136	Rod, Push, Exhaust
552 231597	Bushing, Governor Crank	1029 224554	Arm, Rocker
562 92613	Bolt, Governor Lever	1033 495992	Valve Overhaul Kit
592 231082	Nut, Hex	1034 495248	Guide Assembly, Push Rod
601 93053	Clamp, Fuel Pipe	1044 94673	Screw, Hex Head
611 493496	Elbow, Fuel Pipe	1054 270723	Tie, Cable
614 93306	Pin, Cotter	1058 272623	Manual, Owner's
615 93307	Retainer, E-Ring	1090 497607	Retainer, Brush
618 262803	Spring, Choke Return		
634 281168	** Seal, Choke Shaft		
634A 491323	* Seal, Governor		
634B 281167	** Washer, Throttle Shaft		
635 280872	Elbow, Spark Plug		
646 224546	Brace, Air Cleaner		
657 93496	Screw, Sems		
663 94620	Screw, Self-Tapping		
668 280848	Spacer		
718 230192	Pin, Dowel		
726 392134	Gear, Ring (Includes Mounting Hardware)		
727 490324	Cover, Starter		
728 94627	Screw, Hex Head		

RPM Settings: Low: 1650-1850, High: 3200-3400

* Included in Gasket Set (495993)

** Included in Carburetor Kit (497535)

*** Included in both Gasket Set (495993) and Valve Overhaul Kit (495992)

**** Included in Gasket Set (495993), Carburetor Kit (497535) and Carburetor Gasket Set (494385)

NOTE: All component dimensions given in U.S. inches
1 inch = 25.4 mm

SERVICE NOTES

SUGGESTED GUIDE FOR SIGHTING SLOPES FOR SAFE OPERATION

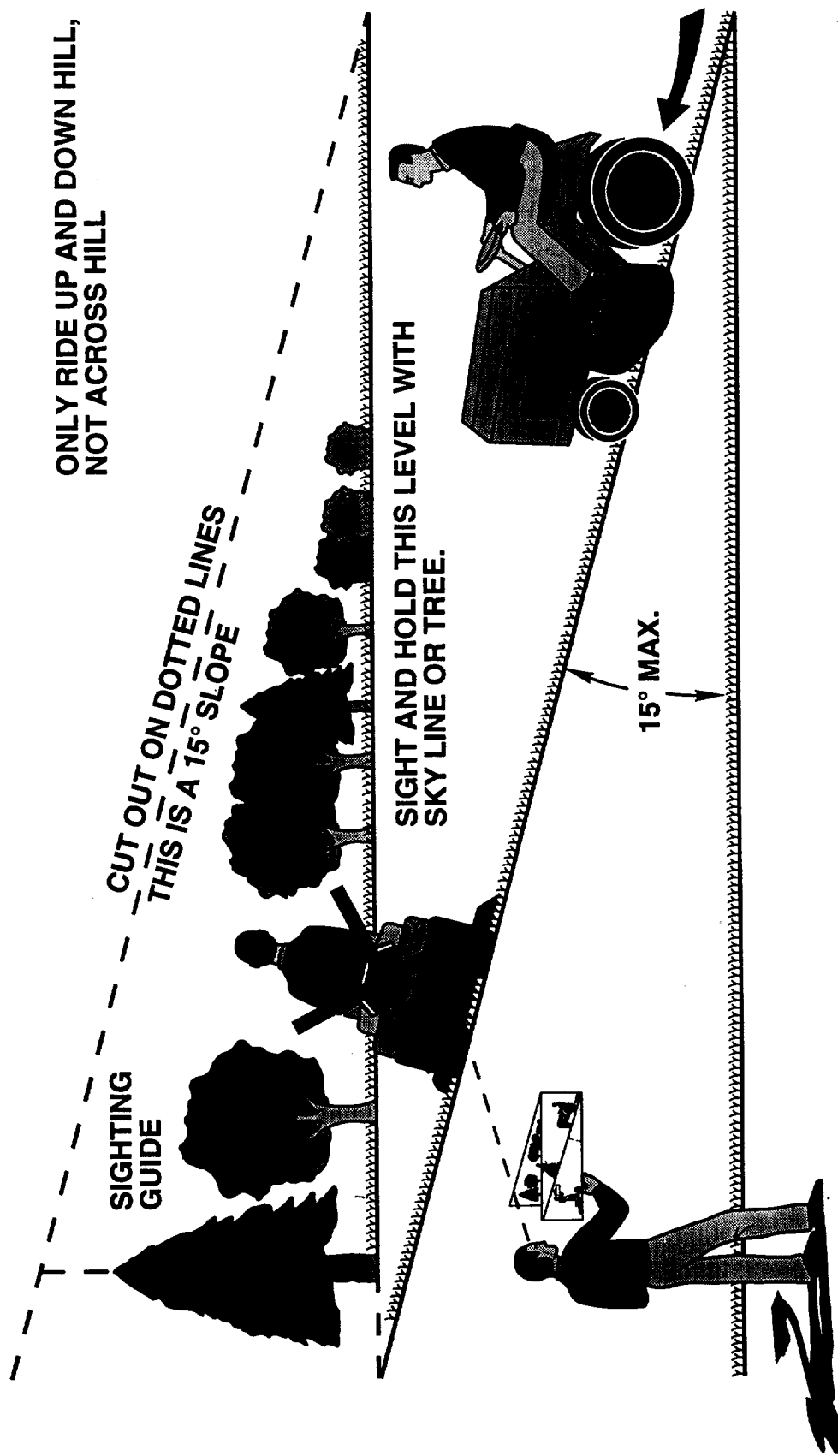

 Operate your Tractor up and down the face of slopes (not greater than 15°), never across the face. Make turns gradually to prevent tipping or loss of control. Exercise extreme caution when changing direction on slopes.

SEARS

OWNER'S MANUAL

**MODEL NO.
917.252520**

IF YOU NEED REPAIR SERVICE OR PARTS:

FOR REPAIR SERVICE, CALL
THIS TOLL FREE NUMBER:

1-800-4-REPAIR
(1-800-473-7247)

FOR REPLACEMENT PARTS
INFORMATION AND
ORDERING, CALL THIS
TOLL FREE NUMBER:

1-800-FON-PART
(1-800-366-7278)

FOR CONSUMER ASSISTANCE
HOT LINE, CALL THIS
TOLL FREE NUMBER:

1-800-659-5917

CRAFTSMAN®

15.0 HP IC ELECTRIC START 3 in One Convertible 42" MOWER 6 SPEED TRANSAXLE LAWN TRACTOR

Each tractor has its own model number. Each engine has its own model number.

The model number for your tractor will be found on the model plate located under the seat.

The model number for your engine will be found on the blower housing of the engine.

All parts listed herein may be ordered from any Sears, Roebuck and Co. Service Center/Department and most Retail Stores.

WHEN ORDERING REPAIR PARTS, ALWAYS GIVE THE FOLLOWING INFORMATION:

- **PRODUCT - TRACTOR**
- **MODEL NUMBER - 917.252520**
- **ENGINE MODEL NO. - 28N707, TYPE NO. 0162-01**
- **PART NUMBER**
- **PART DESCRIPTION**

Your Sears merchandise has added value when you consider Sears has service units nationwide staffed with Sears trained technicians... professional technicians specifically trained to insure that we meet our pledge to you, we service what we sell.