

Owner's Manual

CRAFTSMAN®

**16.5 HP
ELECTRIC START
42" MOWER
6 SPEED TRANSAXLE
LAWN TRACTOR**

EZ³

Model No.
917.271110

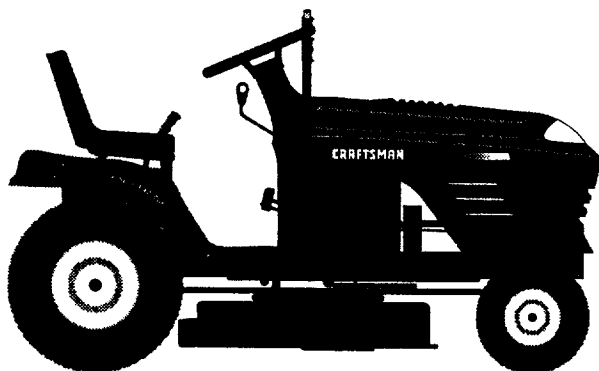

- Safety
- Assembly
- Operation
- Maintenance
- Repair Parts



This product has a low emission engine which operates differently from previously built engines. Before you start the engine, read and understand this Owner's Manual.

CAUTION:

Read and follow all Safety Rules and Instructions before operating this equipment.

For answers to your questions about this product, Call:

1-800-659-5917
Sears Craftsman Help Line
5 am - 5 pm, Mon - Sat

Sears, Roebuck and Co., Hoffman Estates, IL 60179

TABLE OF CONTENTS

Warranty	2	Product Specifications	5
Safety Rules	2	Service and Adjustments	23
Assembly	8	Storage	29
Operation	12	Troubleshooting	30
Maintenance Schedule	19	Repair Parts	34
Maintenance	19	Parts Ordering	Back Cover

WARRANTY

LIMITED TWO YEAR WARRANTY ON CRAFTSMAN RIDING EQUIPMENT

For two (2) years from the date of purchase, if this Craftsman Riding Equipment is maintained, lubricated and tuned up according to the instructions in the owner's manual, Sears will repair or replace, free of charge, any parts found to be defective in material or workmanship.

This Warranty does not cover:

- Expendable items which become worn during normal use, such as blades, spark plugs, air cleaners, belts, etc.
- Tire replacement or repair caused by punctures from outside objects, such as nails, thorns, stumps, or glass.
- Repairs necessary because of operator abuse, negligence, improper storage or accident or the failure to maintain the equipment according to the instructions contained in the owner's manual.
- Riding equipment used for commercial or rental purposes.

LIMITED 90 DAY WARRANTY ON BATTERY

For ninety (90) days from date of purchase, if any battery included with this riding equipment proves defective in material or workmanship and our testing determines the battery will not hold a charge, Sears will replace the battery at no charge. In-home warranty service on your Craftsman riding equipment is available at no charge for 30 days from the date of purchase. Please contact your nearest service center. After 30 days from the date of purchase, warranty service is available by taking your Craftsman riding equipment to your nearest Sears Service Center. (In-home warranty service will still be available after 30 days from the date of purchase but a standard trip charge will apply). This warranty applies only while this product is in the United States. This Warranty gives you specific legal rights, and you may also have other rights which may vary from state to state.

Sears, Roebuck and Co., D/817 WA, Hoffman Estates, IL 60179

SAFETY RULES

GENERAL OPERATION

- Read, understand, and follow all instructions in the manual and on the machine before starting.
- Only allow responsible adults, who are familiar with the instructions, to operate the machine.
- Clear the area of objects such as rocks, toys, wire, etc., which could be picked up and thrown by the blade.
- Be sure the area is clear of other people before mowing. Stop machine if anyone enters the area.
- Never carry passengers.
- Do not mow in reverse unless absolutely necessary. Always look down and behind before and while backing.
- Be aware of the mower discharge direction and do not point it at anyone. Do not operate the mower without either the entire grass catcher or the guard in place.
- Slow down before turning.
- Never leave a running machine unattended. Always turn off blades, set parking brake, stop engine, and remove keys before dismounting.

SAFETY RULES

- Turn off blades when not mowing.
- Stop engine before removing grass catcher or unclogging chute.
- Mow only in daylight or good artificial light.
- Do not operate the machine while under the influence of alcohol or drugs.
- Watch for traffic when operating near or crossing roadways.
- Use extra care when loading or unloading the machine into a trailer or truck.

SLOPE OPERATION

Slopes are a major factor related to loss-of-control and tipover accidents, which can result in severe injury or death. All slopes require extra caution. If you cannot back up the slope or if you feel uneasy on it, do not mow it.

DO:

- Mow up and down slopes, not across.
- Remove obstacles such as rocks, tree limbs, etc.
- Watch for holes, ruts, or bumps. Uneven terrain could overturn the machine. Tall grass can hide obstacles.
- Use slow speed. Choose a low gear so that you will not have to stop or shift while on the slope.
- Follow the manufacturer's recommendations for wheel weights or counterweights to improve stability.
- Use extra care with grass catchers or other attachments. These can change the stability of the machine.
- Keep all movement on the slopes slow and gradual. Do not make sudden changes in speed or direction.
- Avoid starting or stopping on a slope. If tires lose traction, disengage the blades and proceed slowly straight down the slope.

DO NOT:

- *Do not* turn on slopes unless necessary, and then, turn slowly and gradually downhill, if possible.
- *Do not* mow near drop-offs, ditches, or embankments. The mower could suddenly turn over if a wheel is over the edge of a cliff or ditch, or if an edge caves in.
- *Do not* mow on wet grass. Reduced traction could cause sliding.

- *Do not* try to stabilize the machine by putting your foot on the ground.
- *Do not* use grass catcher on steep slopes.

CHILDREN

Tragic accidents can occur if the operator is not alert to the presence of children. Children are often attracted to the machine and the mowing activity. *Never* assume that children will remain where you last saw them.

- Keep children out of the mowing area and under the watchful care of another responsible adult.
- Be alert and turn machine off if children enter the area.
- Before and when backing, look behind and down for small children.
- Never carry children. They may fall off and be seriously injured or interfere with safe machine operation.
- Never allow children to operate the machine.
- Use extra care when approaching blind corners, shrubs, trees, or other objects that may obscure vision.

SERVICE

- Use extra care in handling gasoline and other fuels. They are flammable and vapors are explosive.
 - Use only an approved container.
 - Never remove gas cap or add fuel with the engine running. Allow engine to cool before refueling. Do not smoke.
 - Never refuel the machine indoors.
 - Never store the machine or fuel container inside where there is an open flame, such as a water heater.
- Never run a machine inside a closed area.
- Keep nuts and bolts, especially blade attachment bolts, tight and keep equipment in good condition.
- Never tamper with safety devices. Check their proper operation regularly.
- Keep machine free of grass, leaves, or other debris build-up. Clean oil or fuel spillage. Allow machine to cool before storing.
- Stop and inspect the equipment if you strike an object. Repair, if necessary,

SAFETY RULES

before restarting.

- Never make adjustments or repairs with the engine running.
- Grass catcher components are subject to wear, damage, and deterioration, which could expose moving parts or allow objects to be thrown. Frequently check components and replace with

manufacturer's recommended parts, when necessary.

- Mower blades are sharp and can cut. Wrap the blade(s) or wear gloves, and use extra caution when servicing them.
- Check brake operation frequently. Adjust and service as required.



- Be sure the area is clear of other people before mowing. Stop machine if anyone enters the area.
- Never carry passengers.
- Do not mow in reverse unless absolutely necessary. Always look down and behind before and while backing.
- Never carry children. They may fall off and be seriously injured or interfere with safe machine operation.
- Keep children out of the mowing area and under the watchful care of another responsible adult.
- Be alert and turn machine off if children enter the area.
- Before and when backing, look behind and *down* for small children.
- Mow up and down slopes (15° Max), not across.
- Remove obstacles such as rocks, tree limbs, etc.
- Watch for holes, ruts, or bumps. Uneven terrain could overturn the machine. *Tall grass can hide obstacles.*
- Use slow speed. Choose a low gear so that you will not have to stop or shift while on the slope.
- Avoid starting or stopping on a slope. If tires lose traction, disengage the blades and proceed slowly *straight* down the slope.
- *Do not* turn on slopes unless necessary, and then, turn slowly and gradually downhill, if possible.

▲ Look for this symbol to point out important safety precautions. It means **CAUTION!!! BECOME AWARE!!! YOUR SAFETY IS INVOLVED.**

▲ **WARNING:** The engine exhaust from this product contains chemicals known to the State of California to cause cancer, birth defects, or other reproductive harm.

▲ **CAUTION:** In order to prevent accidental starting when setting up, transporting, adjusting or making repairs always disconnect spark plug wire and place wire where it cannot contact spark plug.

PRODUCT SPECIFICATIONS

GASOLINE CAPACITY AND TYPE:	1.25 GALLONS UNLEADED REGULAR
OIL TYPE (API-SF/SG/SH):	SAE 30 (above 32°F) SAE 10W-30 (below 32°F)
OIL CAPACITY:	W/FILTER: 4.0 PINTS W/O FILTER: 3.5 PINTS
SPARK PLUG: (GAP: .030")	Champion J19LM STD361458-
GROUND SPEED FORWARD: (MPH):	1ST 1.1 2ND 1.4 3RD 2.3 4TH 3.5 5TH 4.5 6TH 6.0 REVERSE: 1.7
TIRE PRESSURE:	FRONT: 14 PSI REAR: 10 PSI
CHARGING SYSTEM:	3 AMPS BATTERY 5 AMPS HEADLIGHTS
BATTERY:	AMP/HR: 20 MIN. CCA:240 CASE SIZE: U1R
BLADE BOLT TORQUE:	27-35 FT. LBS.

CONGRATULATIONS on your purchase of a Craftsman Tractor. It has been designed, engineered and manufactured to give you the best possible dependability and performance.

Should you experience any problem you cannot easily remedy, please contact your nearest Sears Authorized Service Center. We have competent, well-trained technicians and the proper tools to service or repair this tractor.

Please read and retain this manual. The instructions will enable you to assemble and maintain your tractor properly. Always observe the "SAFETY RULES".

MAINTENANCE AGREEMENT

A Sears Maintenance Agreement is available on this product. Contact your nearest Sears store for details.

CUSTOMER RESPONSIBILITIES

- Read and observe the safety rules.
- Follow a regular schedule in maintaining, caring for and using your tractor.
- Follow the instructions under "Maintenance" and "Storage" sections of this owner's manual.

▲WARNING: This tractor is equipped with an internal combustion engine and should not be used on or near any unimproved forest-covered, brush-covered or grass-covered land unless the engine's exhaust system is equipped with a spark arrester meeting applicable local or state laws (if any). If a spark arrester is used, it should be maintained in effective working order by the operator.

In the state of California the above is required by law (Section 4442 of the California Public Resources Code). Other states may have similar laws. Federal laws apply on federal lands. A spark arrester for the muffler is available through your nearest Sears Authorized Service Center (See REPAIR PARTS section of this manual).

CONTENTS OF HARDWARE PACK

Parts Bag contents shown full size

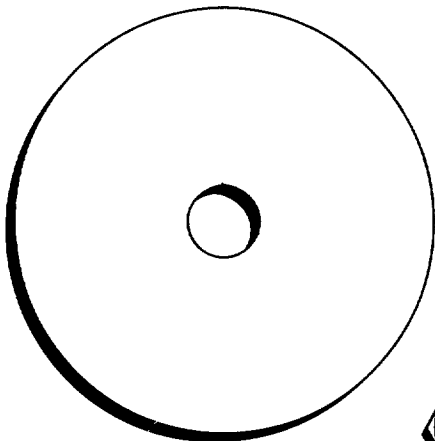

(1) Large Flat Washer



(1) Hex Bolt 5/16-18 x 1-1/4



(1) Lockwasher 3/8

(1) Hex Bolt
3/8-16 x 1

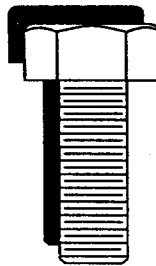

(1) Locknut 5/16-18

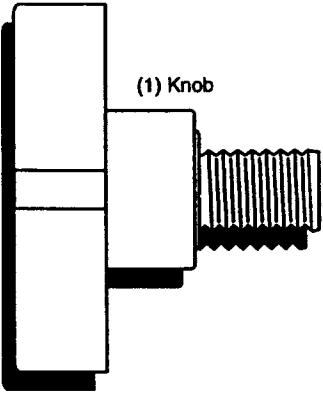

(1) Knob

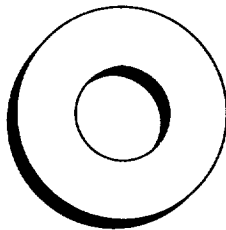

(1) Washer
17/32 x 1-3/16 x 12 Gauge

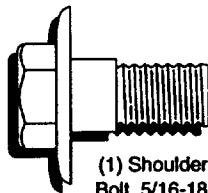

(1) Shoulder
Bolt 5/16-18

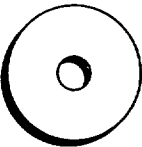

(2) Washers
3/16 x 3/4 x 16 Gauge



(2) Screws #10 x 5/8



(2) Hex Bolts 1/4-20 x 3/4



(2) Washers
9/32 x 5/8 x 16 Gauge

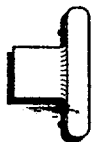

(2) Weld
Nuts #10



(2) Lock
Washers #10



(2) Lock
Washers 1/4



(2) Hex
Nuts
1/4-20

CONTENTS OF HARDWARE PACK

Parts packed separately in carton

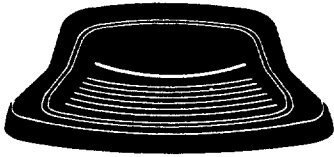

Seat

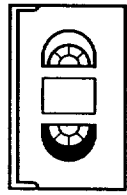

Video
Cassette

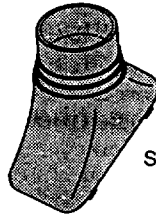

Steering
Boot

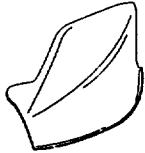

Mulcher
Plate

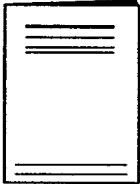

Manual

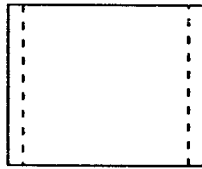

Parts Bag

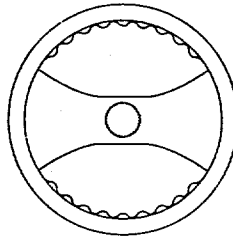

Steering
Wheel

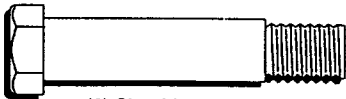

(2) Shoulder
Bolts



(2) Center-
lock Nuts



(2) Washers 3/8
x 7/8 x 14 Gauge

Parts Bag contents not shown full size

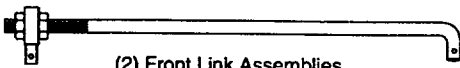

(2) Front Link Assemblies



Steering
Wheel
Insert

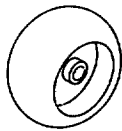

(2) Gauge
Wheels

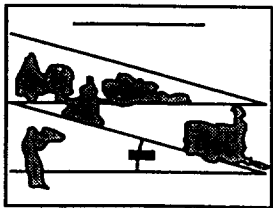

Slope Sheet

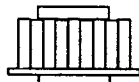

Steering Wheel
Adapter

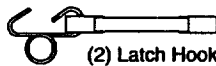

(2) Latch Hook
Assemblies



(2) Keys

ASSEMBLY

Your new tractor has been assembled at the factory with exception of those parts left unassembled for shipping purposes. To ensure safe and proper operation of your tractor all parts and hardware you assemble must be tightened securely. Use the correct tools as necessary to insure proper tightness. Review the video cassette before you begin.

TOOLS REQUIRED FOR ASSEMBLY

A socket wrench set will make assembly easier. Standard wrench sizes you need are listed below.

- | | |
|--------------------|----------------------------------|
| (1) 9/16" wrench | (1) 3/4" Socket w/ drive ratchet |
| (2) 7/16" wrenches | (1) Phillips Screwdriver |
| (2) 1/2" wrench | (1) Tire pressure gauge |
| (1) 3/4" wrench | |
| (1) Utility knife | |
| (1) Pliers | |

When right or left hand is mentioned in this manual, it means, from your point of view, when you are in the operating position (seated behind the steering wheel).

TO REMOVE TRACTOR FROM CARTON

UNPACK CARTON

- Remove all accessible loose parts and parts boxes from shipping carton (See page 6).
- Cut, from top to bottom, along lines on all four corners of shipping carton, and lay panels flat.
- Remove mower and package materials.
- Check for any additional loose parts or boxes and remove.

BEFORE ROLLING TRACTOR OFF SKID

ATTACH STEERING WHEEL

ASSEMBLE EXTENSION SHAFT AND BOOT

- Slide extension shaft onto lower steering shaft. Align mounting holes in extension and lower shafts and install 5/16 hex bolt and locknut. Tighten securely.

IMPORTANT: Tighten bolt and nut securely to 18-22 ft. lbs. torque.

- Place tabs of steering boot over tab slots in dash and push down to secure.

INSTALL STEERING WHEEL

- Position front wheels of the tractor so they are pointing straight forward.
- Slide steering wheel adapter onto steering shaft extension.
- Position steering wheel so cross bars

are horizontal (left to right) and slide inside boot and onto adapter.

- Assemble large flat washer, 3/8 lock washer, 3/8 hex bolt and tighten securely.
- Snap steering wheel insert into center of steering wheel.
- Remove protective materials from tractor hood and grill.

IMPORTANT: Check for and remove any staples in skid that may puncture tires where tractor is to roll off skid.

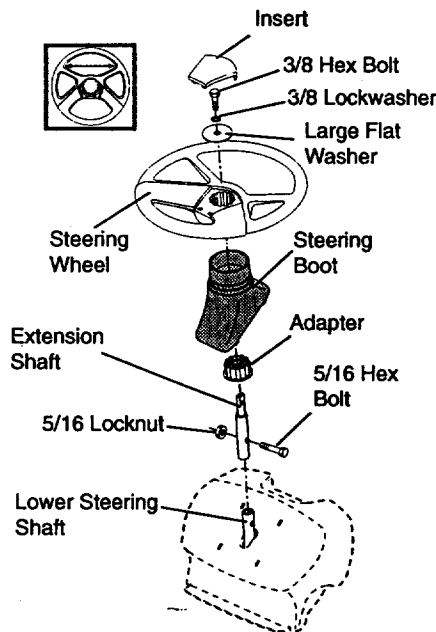

TO ROLL TRACTOR OFF SKID (See Operation section for location and function of controls)

- Press lift lever plunger and raise attachment lift lever to its highest position.
- Release parking brake by depressing clutch/brake pedal.
- Place freewheel control in freewheeling position to disengage transmission (See "TO TRANSPORT" in the Operation section of this manual).
- Roll tractor backwards off skid.
- Remove banding holding discharge guard up against tractor.

HOW TO SET UP YOUR TRACTOR CONNECT BATTERY

CAUTION: Do not short battery terminals by allowing a wrench or any other object to contact both terminals at the same time. Before connecting battery, remove metal bracelets, wristwatch bands, rings, etc. Positive terminal must be connected first to prevent sparking from accidental grounding.

- Remove cardboard packing from seat pan and lift seat pan to raised position.
- Open battery box door and remove protective plastic.
- Remove terminal protective caps and discard.
- If this battery is put into service after month and year indicated on label (label located between terminals) charge battery for minimum of one hour at 6-10 amps.
- First connect RED battery cable to positive (+) terminal with hex bolt, flat washer, lock washer and hex nut as shown. Tighten securely.
- Connect BLACK grounding cable to negative (-) terminal with remaining hex bolt, flat washer, lock washer and hex nut. Tighten securely.

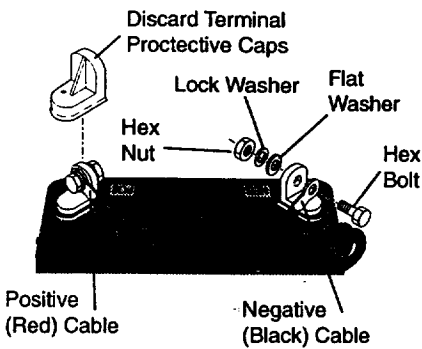

- Close battery box door. Open battery box door for:
 - Inspection for secure connections (to tighten hardware).
 - Inspection for corrosion.
 - Testing battery.
 - Jumping (if required).
 - Periodic charging.

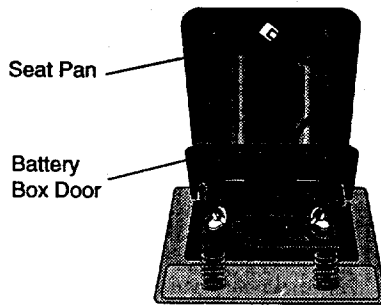

INSTALL SEAT

Adjust seat before tightening adjustment knob.

- Remove cardboard packing on seat pan.
- Place seat on seat pan and assemble shoulder bolt. Tighten shoulder bolt securely.
- Assemble adjustment knob and flat washer loosely. Do not tighten.
- Lower seat into operating position and sit on seat.
- Slide seat until a comfortable position is reached which allows you to press clutch/brake pedal all the way down.
- Get off seat without moving its adjusted position.
- Raise seat and tighten adjustment knob securely.

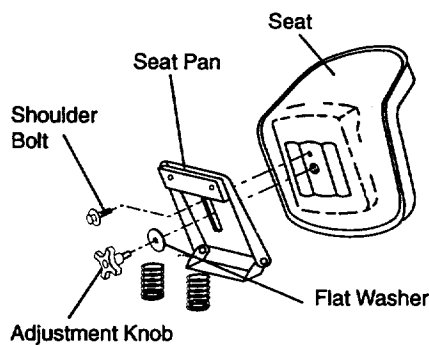

CHECK TIRE PRESSURE

The tires on your tractor were overinflated at the factory for shipping purposes. Correct tire pressure is important for best cutting performance.

- Reduce tire pressure to PSI shown in "PRODUCT SPECIFICATIONS" on page 5 of this manual.

CHECK DECK LEVELNESS

For best cutting results, mower housing should be properly leveled. See "TO LEVEL MOWER HOUSING" in the Service and Adjustments section of this manual.

CHECK FOR PROPER POSITION OF ALL BELTS

See the figures that are shown for replacing motion and mower blade drive belts in the Service and Adjustments section of this manual. Verify that the belts are routed correctly.

CHECK BRAKE SYSTEM

After you learn how to operate your tractor, check to see that the brake is properly adjusted. See "TO ADJUST BRAKE" in the Service and Adjustments section of this manual.

INSTALL MULCHER PLATE

- Install two latch hooks to mulcher plate using screw, washer, lock washer, and weld nut as shown.

NOTE: Pre-assemble weld nut to latch hook by inserting weld nut from the top with hook pointing down.

- Tighten hardware securely.
- Raise and hold deflector shield in upright position.
- Place front of mulcher plate over front of mower deck opening and slide into place, as shown.
- Hook front latch into hole on front of mower deck.
- Hook rear latch into hole on back of mower deck.

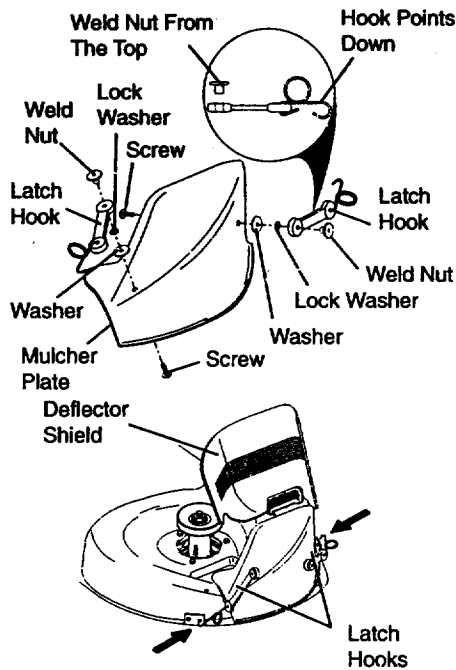

CAUTION: Do not remove discharge guard from mower. Raise and hold guard when attaching mulcher plate and allow it to rest on plate while in operation.

TO CONVERT TO BAGGING OR DISCHARGING

Simply remove mulcher plate and store in a safe place. Your mower is now ready for discharging or installation of optional grass catcher accessory.

NOTE: It is not necessary to change blades. The mulcher blades are designed for discharging and bagging also.

ASSEMBLE GAUGE WHEELS TO MOWER DECK

The gauge wheels are designed to keep the mower deck in proper position when operating mower. Be sure they are properly adjusted to ensure optimum mower performance.

- Assemble gauge wheels with tractor on a flat level surface.
- Adjust mower to desired cutting height (See "TO ADJUST MOWER CUTTING HEIGHT" in the Operation section of this manual).
- With mower in desired height of cut position, gauge wheels should be assembled so they are slightly off the ground. Install gauge wheel in appropriate hole with shoulder bolt, 3/8 washer, and 3/8-16 locknut and tighten securely.
- Repeat for opposite side installing gauge wheel in same adjustment hole.

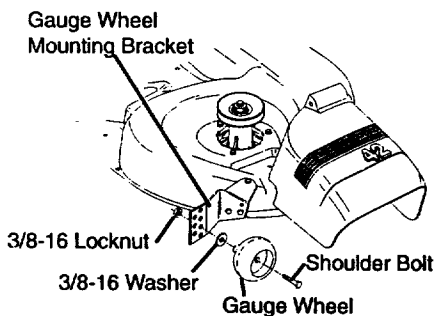

✓ CHECKLIST

PLEASE REVIEW THE FOLLOWING CHECKLIST:

- ✓ All assembly instructions have been completed.
- ✓ No remaining loose parts in carton.
- ✓ Battery is properly prepared and charged. (Minimum 1 hour at 6 amps).
- ✓ Seat is adjusted comfortably and tightened securely.
- ✓ All tires are properly inflated. (For shipping purposes, the tires were overinflated at the factory).
- ✓ Be sure mower deck is properly leveled side-to-side/front-to-rear for best cutting results. (Tires must be properly inflated for leveling).
- ✓ Check mower and drive belts. Be sure they are routed properly around pulleys and inside all belt keepers.
- ✓ Check wiring. See that all connections are still secure and wires are properly clamped.
- ✓ Before driving tractor, be sure free-wheel control is in drive position.

WHILE LEARNING HOW TO USE YOUR TRACTOR, PAY EXTRA ATTENTION TO THE FOLLOWING IMPORTANT ITEMS:

- ✓ Engine oil is at proper level.
- ✓ Fuel tank is filled with fresh, clean, regular unleaded gasoline.
- ✓ Become familiar with all controls - their location and function. Operate them before you start the engine.
- ✓ Be sure brake system is in safe operating condition.
- ✓ It is important to purge the transmission before operating your tractor for the first time. Follow proper starting and transmission purging instructions (See "TO START ENGINE" and "PURGE TRANSMISSION" in the Operation section of this manual).

OPERATION

These symbols may appear on your tractor or in literature supplied with the product. Learn and understand their meaning.

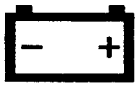

BATTERY



CAUTION OR WARNING



REVERSE



FORWARD



FAST



SLOW



ENGINE ON



ENGINE OFF



OIL PRESSURE



LIGHTS ON



OVER TEMP LIGHT



MOWER LIFT



FUEL



CHOKE



MOWER HEIGHT



PARKING BRAKE LOCKED



UNLOCKED



ATTACHMENT CLUTCH ENGAGED



REVERSE



NEUTRAL



HIGH



LOW



PARKING BRAKE



IGNITION



ATTACHMENT CLUTCH DISENGAGED



KEEP AREA CLEAR



SLOPE HAZARDS

(SEE SAFETY RULES SECTION)



DANGER, KEEP HANDS AND FEET AWAY

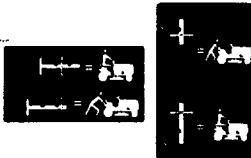

HYDROSTATIC FREE WHEEL
(Hydro Models only)

KNOW YOUR TRACTOR

READ THIS OWNER'S MANUAL AND SAFETY RULES BEFORE OPERATING YOUR TRACTOR

Compare the illustrations with your tractor to familiarize yourself with the locations of various controls and adjustments. Save this manual for future reference.

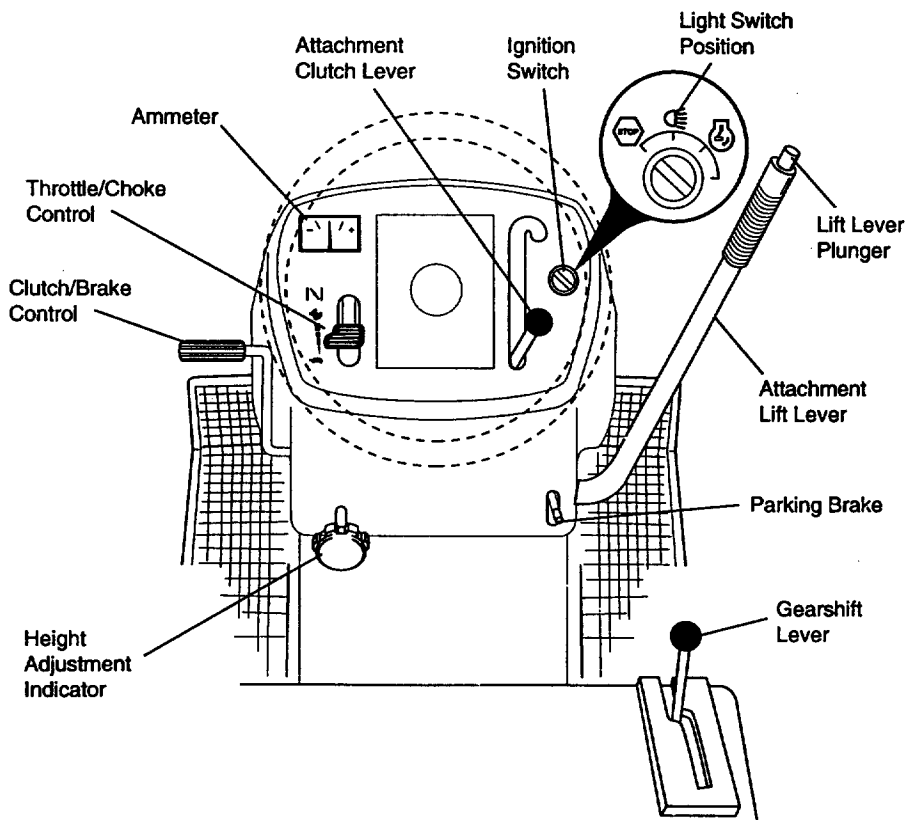

Our tractors conform to the safety standards of the American National Standards Institute.

ATTACHMENT CLUTCH LEVER: Used to engage the mower blades, or other attachments mounted to your tractor.

LIGHT SWITCH: Turns the headlights on and off.

THROTTLE/CHOKE CONTROL: Used to control engine speed.

CLUTCH/BRAKE PEDAL: Used for declutching and braking the tractor and starting the engine.

HEIGHT ADJUSTMENT KNOB: Used to adjust the mower cutting height.

GEARSHIFT LEVER: Selects the speed and direction of the tractor.

ATTACHMENT LIFT LEVER: Used to raise and lower the mower deck or other attachments mounted to your tractor.

LIFT LEVER PLUNGER: Used to release attachment lift lever when changing its position.

IGNITION SWITCH: Used for starting and stopping the engine.

AMMETER: Indicates battery charging (+) or discharging (-).

PARKING BRAKE: Locks clutch/brake into the brake position.



The operation of any tractor can result in foreign objects thrown into the eyes, which can result in severe eye damage. Always wear safety glasses or eye shields while operating your tractor or performing any adjustments or repairs. We recommend a wide vision safety mask over the spectacles, or standard safety glasses.

HOW TO USE YOUR TRACTOR

Your tractor is equipped with an operator presence sensing switch. When engine is running, any attempt by the operator to leave the seat without first setting the parking brake will shut off the engine.

TO SET PARKING BRAKE

- Depress clutch/brake pedal into full "BRAKE" position and hold.
- Place parking brake lever in "ENGAGED" position and release pressure from clutch/brake pedal. Pedal should remain in "BRAKE" position. Make sure parking brake will hold tractor secure.

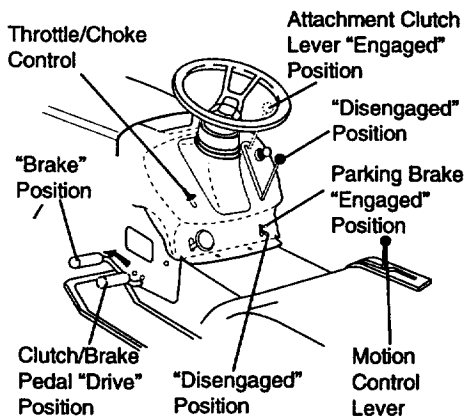

STOPPING

MOWER BLADES -

- Move attachment clutch lever to "DIS-ENGAGED" position.

GROUND DRIVE -

- Depress clutch/brake pedal into full "BRAKE" position.
- Move gearshift lever to neutral (N) position.

ENGINE -

- Move throttle control to slow position.
- NOTE:** Failure to move throttle control to slow position and allowing engine to idle before stopping may cause engine to "backfire".
- Turn ignition key to "OFF" position and

remove key. Always remove key when leaving tractor to prevent unauthorized use.

- Never use choke to stop engine.

NOTE: Under certain conditions when tractor is standing idle with the engine running, hot engine exhaust gases may cause "browning" of grass. To eliminate this possibility, always stop engine when stopping tractor on grass areas.

▲ CAUTION: Always stop tractor completely, as described above, before leaving the operator's position; to empty grass catcher, etc.

THROTTLE CONTROL

Always operate engine at full throttle.

- Operating engine at less than full throttle reduces the battery charging rate.
- Full throttle offers the best bagging and mower performance.

TO MOVE FORWARD AND BACKWARD

The direction and speed of movement is controlled by the gearshift lever.

- Start tractor with clutch/brake pedal depressed and gearshift lever in neutral (N) position.
- Move gearshift lever to desired position.
- Slowly release clutch/brake pedal to start movement.

IMPORTANT: Bring tractor to a complete stop before shifting or changing gears. Failure to do so will shorten the useful life of your transaxle.

TO ADJUST MOWER CUTTING HEIGHT

The cutting height is controlled by turning the height adjustment knob in desired direction.

- Turn knob clockwise () to raise cutting height.
- Turn knob counterclockwise () to lower cutting height.

The cutting height range is approximately 1-1/2" to 4". The heights are measured from the ground to the blade tip with the engine not running. These heights are approximate and may vary depending upon soil conditions, height of grass and types of grass being mowed.

- The average lawn should be cut to approximately 2-1/2 inches during the cool season and to over 3 inches during hot months. For healthier and better looking lawns, mow often and after moderate growth.
- For best cutting performance, grass over 6 inches in height should be mowed twice. Make the first cut relatively high; the second to desired height.

TO OPERATE MOWER

Your tractor is equipped with an operator presence sensing switch. Any attempt by the operator to leave the seat with the engine running and the attachment clutch engaged will shut off the engine.

- Select desired height of cut.
- Lower mower with attachment lift control.
- Start mower blades by engaging attachment clutch control.
- to Stop mower blades - disengage attachment clutch control.

▲ CAUTION: Do not operate the mower without either the entire grass catcher, on mowers so equipped, or the discharge guard in place.

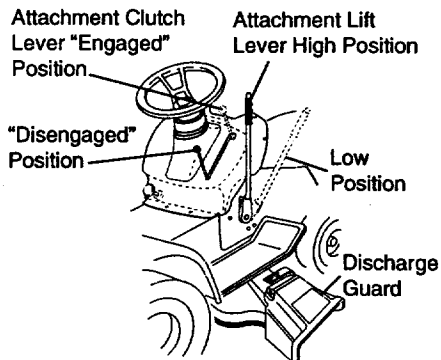

TO OPERATE ON HILLS

▲ CAUTION: Do not drive up or down hills with slopes greater than 15° and do not drive across any slope.

- Choose the slowest speed before starting up or down hills.
- Avoid stopping or changing speed on hills.
- If slowing is necessary, move throttle control lever to slower position.
- If stopping is absolutely necessary, push clutch/brake pedal quickly to brake position and engage parking brake.
- Move gearshift lever to 1st gear. Be

sure you have allowed room for tractor to roll slightly as you restart movement.

- To restart movement, slowly release parking brake and clutch/brake pedal.
- Make all turns slowly.

TO TRANSPORT

- Raise attachment lift to highest position with attachment lift control.
- When pushing or towing your tractor, be sure gearshift lever is in neutral (N) position.
- Do not push or tow tractor at more than five (5) MPH.

NOTE: To protect hood from damage when transporting your tractor on a truck or a trailer, be sure hood is closed and secured to tractor. Use an appropriate means of tying hood to tractor (rope, cord, etc.).

TOWING CARTS AND OTHER ATTACHMENTS

Tow only the attachments that are recommended by and comply with specifications of the manufacturer of your tractor. Use common sense when towing. Too heavy of a load, while on a slope, is dangerous. Tires can lose traction with the ground and cause you to lose control of your tractor.

BEFORE STARTING THE ENGINE CHECK ENGINE OIL LEVEL

- The engine in your tractor has been shipped, from the factory, already filled with summer weight oil.
- Check engine oil with tractor on level ground.
- Unthread and remove oil fill cap/dipstick; wipe oil off. Reinsert the dipstick into the tube and rest oil fill cap on the tube. Do not thread the cap onto the tube. Remove and read oil level. If necessary, add oil until "FULL" mark on dipstick is reached. Do not overfill.
- For cold weather operation you should change oil for easier starting (See "OIL VISCOSITY CHART" in the Customer Responsibilities section of this manual).
- To change engine oil, see the Customer Responsibilities section in this manual.

ADD GASOLINE

- Fill fuel tank. Use fresh, clean, regular unleaded gasoline with a minimum of 87 octane. (Use of leaded gasoline will increase carbon and lead oxide deposits and reduce valve life). Do not

mix oil with gasoline. Purchase fuel in quantities that can be used within 30 days to assure fuel freshness.

IMPORTANT: When operating in temperatures below 32°F(0°C), use fresh, clean winter grade gasoline to help insure good cold weather starting.

▲WARNING: Experience indicates that alcohol blended fuels (called gasohol or using ethanol or methanol) can attract moisture which leads to separation and formation of acids during storage. Acidic gas can damage the fuel system of an engine while in storage. To avoid engine problems, the fuel system should be emptied before storage of 30 days or longer. Drain the gas tank, start the engine and let it run until the fuel lines and carburetor are empty. Use fresh fuel next season. See Storage Instructions for additional information. Never use engine or carburetor cleaner products in the fuel tank or permanent damage may occur.

▲CAUTION: Fill to bottom of gas tank filler neck. Do not overfill. Wipe off any spilled oil or fuel. Do not store, spill or use gasoline near an open flame.

TO START ENGINE

When starting the engine for the first time or if the engine has run out of fuel, it will take extra cranking time to move fuel from the tank to the engine.

- Sit on seat in operating position, depress clutch/brake pedal and set parking brake.
- Place gear shift lever in neutral (N) position.
- Move attachment clutch to "DISENGAGED" position.
- Move throttle control to choke position.

Note: Before starting, read the warm and cold starting procedures below.

- Insert key into ignition and turn key clockwise to "START" position and release key as soon as engine starts. Do not run starter continuously for more than fifteen seconds per minute. If the engine does not start after several attempts, move throttle control to fast position, wait a few minutes and try again. If engine still does not start, move the throttle control back to the choke position and retry.

WARM WEATHER STARTING (50° F AND ABOVE)

- When engine starts, move the throttle control to the fast position.
- The attachments and ground drive can now be used. If the engine does not accept the load, restart the engine and allow it to warm up for one minute using the choke as described above.

COLD WEATHER STARTING (50° F AND BELOW)

- When engine starts, allow engine to run with the throttle control in the choke position until the engine runs roughly, then move throttle control to fast position. This may require an engine warm-up period from several seconds to several minutes, depending on the temperature.
- The attachments can also be used during the engine warm-up period.

NOTE: If at a high altitude (above 3000 feet) or in cold temperatures (below 32 F) the carburetor fuel mixture may need to be adjusted for best engine performance. See "TO ADJUST CARBURETOR" in the Service and Adjustments section of this manual.

MOWING TIPS

- Tire chains cannot be used when the mower housing is attached to tractor.
- Mower should be properly leveled for best mowing performance. See "TO LEVEL MOWER HOUSING" in the Service and Adjustments section of this manual.
- The left hand side of mower should be used for trimming.
- Drive so that clippings are discharged onto the area that has been cut. Have the cut area to the right of the tractor. This will result in a more even distribution of clippings and more uniform cutting.

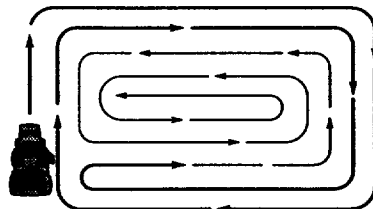

- When mowing large areas, start by turning to the right so that clippings will discharge away from shrubs, fences, driveways, etc. After one or two rounds, mow in the opposite direction making left hand turns until finished.
- If grass is extremely tall, it should be mowed twice to reduce load and possible fire hazard from dried clippings. Make first cut relatively high; the second to the desired height.
- Do not mow grass when it is wet. Wet grass will plug mower and leave undesirable clumps. Allow grass to dry before mowing.
- **Always operate engine at full throttle when mowing** to assure better mowing performance and proper discharge of material. Regulate ground speed by selecting a low enough gear to give the mower the best cutting performance as well as the quality of cut desired.
- When operating attachments, select a ground speed that will suit the terrain and give best performance of the attachment being used.

MULCHING MOWING TIPS

IMPORTANT: For best performance, keep mower housing free of built-up grass and trash. Clean after each use.

- The special mulching blade will recut the grass clippings many times and reduce them in size so that as they fall onto the lawn they will disperse into the grass and not be noticed. Also, the mulched grass will biodegrade quickly to provide nutrients for the lawn. Always

mulch with your highest engine (blade) speed as this will provide the best recutting action of the blades.

- Avoid cutting your lawn when it is wet. Wet grass tends to form clumps and interferes with the mulching action. The best time to mow your lawn is the early

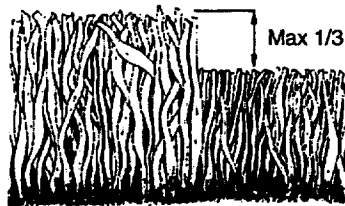

afternoon. At this time the grass has dried and the newly cut area will not be exposed to the direct sun.

- For best results, adjust the mower cutting height so that the mower cuts off only the top one-third of the grass blades. For extremely heavy mulching, reduce your width of cut on each pass and mow slowly.
- Certain types of grass and grass conditions may require that an area be mulched a second time to completely hide the clippings. When doing a second cut, mow across or perpendicular to the first cut path.
- Change your cutting pattern from week to week. Mow north to south one week then change to east to west the next week. This will help prevent matting and graining of the lawn.

MAINTENANCE

CUSTOMER RESPONSIBILITIES

MAINTENANCE SCHEDULE FILL IN DATES AS YOU COMPLETE REGULAR SERVICE		SERVICE DATES																
		BEFORE EACH USE	EVERY 8 HOURS	EVERY 25 HOURS	EVERY 50 HOURS	EVERY 100 HOURS	EVERY SEASON	BEFORE STORAGE										
TRACTOR	Check Brake Operation	✓	✓															
	Check Tire Pressure	✓	✓															
	Check Operator Presence and Interlock Systems	✓																
	Check for Loose Fasteners	✓				✓ ₇		✓										
	Sharpen/Replace Mower Blades			✓ ₄		✓ ₇												
	Lubrication Chart			✓				✓										
	Check Battery Level			✓ ₆														
	Clean Battery and Terminals/Recharge			✓				✓										
	Check Transaxle Cooling			✓														
	Adjust Blade Belt(s) Tension					✓ ₅												
Adjust Motion Drive Belt(s) Tension					✓ ₅													
ENGINE	Check Engine Oil Level	✓	✓					✓										
	Change Engine Oil			✓ _{1,2,3}					✓									
	Clean Air Filter			✓ ₂														
	Clean Air Screen			✓ ₂														
	Inspect Muffler/Spark Arrester				✓													
	Replace Oil Filter (If equipped)					✓ _{1,2}												
	Clean Engine Cooling Fins					✓ ₂												
	Replace Spark Plug					✓ ₂		✓										
Replace Air Filter Paper Cartridge					✓ ₂			✓										
Replace Fuel Filter							✓											

- 1 - Change more often when operating under a heavy load or in high ambient temperatures. 5 - If equipped with adjustable system.
 2 - Service more often when operating in dirty or dusty conditions. 6 - Not required if equipped with maintenance-free battery.
 3 - If equipped with oil filter, change oil every 50 hours. 7 - Tighten front axle pivot bolt to 35 ft.-lbs. maximum.
 4 - Replace blades more often when mowing in sandy soil. Do not overtighten.

GENERAL RECOMMENDATIONS

The warranty on this tractor does not cover items that have been subjected to operator abuse or negligence. To receive full value from the warranty, operator must maintain tractor as instructed in this manual. Some adjustments will need to be made periodically to properly maintain your tractor. All adjustments in the Service and Adjustments section of this manual should be checked at least once each season.

- Once a year you should replace the spark plug, clean or replace air filter, and check blades and belts for wear. A new spark plug and clean air filter assure proper air-fuel mixture and help your engine run better and last longer.

BEFORE EACH USE

- Check engine oil level.
- Check brake operation.
- Check tire pressure.
- Check operator presence and interlock systems for proper operation.
- Check for loose fasteners.

LUBRICATION CHART

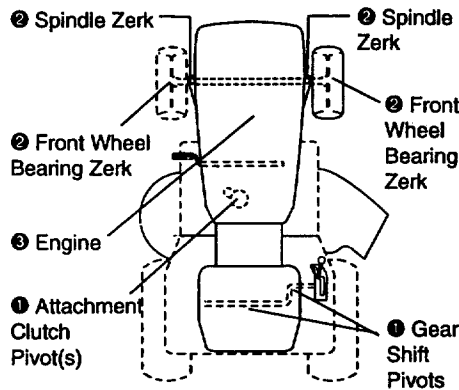

- 1 SAE 30 or 10w30 Motor OIL
- 2 General Purpose Grease
- 3 Refer to Maintenance "Engine" Section

IMPORTANT: Do not oil or grease the pivot points which have special nylon bearings. Viscous lubricants will attract dust and dirt that will shorten the life of the self-lubricating bearings. If you feel they must be lubricated, use only a dry, powdered graphite type lubricant sparingly.

TRACTOR

Always observe safety rules when performing any maintenance.

BRAKE OPERATION

If tractor requires more than six (6) feet stopping distance at high speed in highest gear, then brake must be adjusted. (See "TO ADJUST BRAKE" in the Service and Adjustments section of this manual).

TIRES

- Maintain proper air pressure in all tires (See "PRODUCT SPECIFICATIONS" on page 5 of this manual).
- Keep tires free of gasoline, oil, or insect control chemicals which can harm rubber.
- Avoid stumps, stones, deep ruts, sharp objects and other hazards that may cause tire damage.

NOTE: To seal tire punctures and prevent flat tires due to slow leaks, tire sealant may be purchased from your local parts dealer. Tire sealant also prevents tire dry rot and corrosion.

BLADE CARE

For best results mower blades must be kept sharp. Replace bent or damaged blades.

BLADE REMOVAL

- Raise mower to highest position to allow access to blades.
- Remove hex bolt, lock washer and flat washer securing blade.
- Install new or resharpened blade with trailing edge up towards deck as shown.
- Reassemble hex bolt, lock washer and flat washer in exact order as shown.
- Tighten bolt securely (30-35 Ft. Lbs. torque).

IMPORTANT: Blade bolt is Grade 8 heat treated.

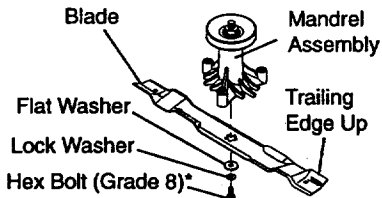

*A Grade 8 heat treated bolt can be identified by six lines on the bolt head.

TO SHARPEN BLADE

NOTE: We do not recommend sharpening blade, but if you do, be sure the blade is balanced.

Care should be taken to keep the blade balanced. An unbalanced blade will cause excessive vibration and eventual damage to mower and engine.

- The blade can be sharpened with a file or on a grinding wheel. Do not attempt to sharpen while it is on the mower.
- To check blade balance, you will need a 5/8" diameter steel bolt, pin, or a cone balancer. (When using a cone balancer, follow the instructions supplied with balancer).

NOTE: Do not use a nail for balancing blade. The lobes of the center hole may appear to be centered, but are not.

- Slide blade onto an unthreaded portion of the steel bolt or pin and hold the bolt or pin parallel with the ground. If blade is balanced, it should remain in a horizontal position. If either end of the blade moves downward, sharpen the heavy end until the blade is balanced.

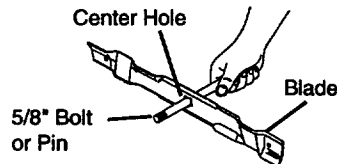

BATTERY

Your tractor has a battery charging system which is sufficient for normal use.

However, periodic charging of the battery with an automotive charger will extend its life.

- Keep battery and terminals clean.
- Keep battery bolts tight.
- Keep small vent holes open.
- Recharge at 6-10 amperes for 1 hour.

TO CLEAN BATTERY AND TERMINALS

Corrosion and dirt on the battery and terminals can cause the battery to "leak" power.

- Open battery box door.
- Disconnect BLACK battery cable first then RED battery cable and remove battery from tractor.
- Rinse the battery with plain water and dry.
- Clean terminals and battery cable ends with wire brush until bright.

- Coat terminals with grease or petroleum jelly.
- Reinstall battery (See "CONNECT BATTERY" in the Assembly section of this manual).

V-BELTS

Check V-belts for deterioration and wear after 100 hours of operation and replace if necessary. The belts are not adjustable. Replace belts if they begin to slip from wear.

TRANSAXLE COOLING

Keep transaxle free from build-up of dirt and chaff which can restrict cooling.

ENGINE LUBRICATION

Only use high quality detergent oil rated with API service classification SF, SG, or SH. Select the oil's SAE viscosity grade according to your expected operating temperature.

Change the oil after every 50 hours of operation or at least once a year if the tractor is not used for 50 hours in one year.

Check the crankcase oil level before starting the engine and after each eight (8) hours of operation. Tighten oil fill cap/dipstick securely each time you check the oil level.

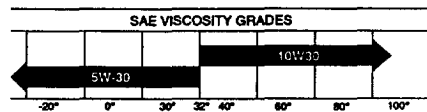

TO CHANGE ENGINE OIL

Determine temperature range expected before oil change. All oil must meet API service classification SF, SG, or SH.

- Be sure tractor is on level surface.
- Oil will drain more freely when warm.
- Catch oil in a suitable container.
- Remove oil fill cap/dipstick. Be careful not to allow dirt to enter the engine when changing oil.
- Remove drain plug.
- After oil has drained completely, replace oil drain plug and tighten securely.
- Refill engine with oil through oil fill dipstick tube. Pour slowly. Do not overfill. For approximate capacity see "PRODUCT SPECIFICATIONS" on page 3 of this manual.

- Use gauge on oil fill cap/dipstick for checking level. Insert dipstick into the tube and rest the oil fill cap on the tube. Do not thread the cap onto the tube when taking reading. Keep oil at "FULL" line on dipstick. Tighten cap onto the tube securely when finished.

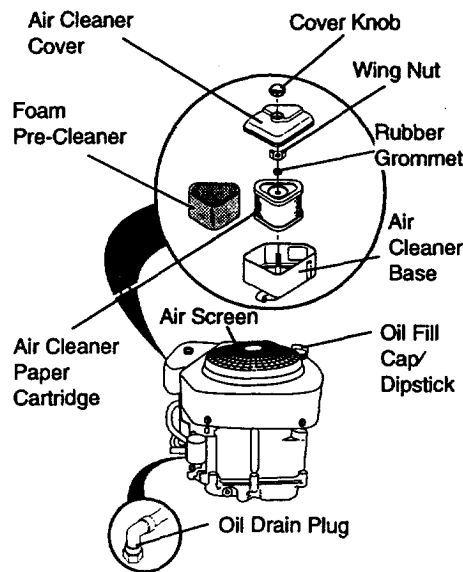

CLEAN AIR SCREEN

Air screen must be kept free of dirt and chaff to prevent engine damage from overheating. Clean with a wire brush or compressed air to remove dirt and stubborn dried gum fibers.

AIR FILTER

Your engine will not run properly using a dirty air filter. Clean the foam pre-cleaner after every 25 hours of operation or every season. Service paper cartridge every 100 hours of operation or every season, whichever occurs first.

Service air cleaner more often under dusty conditions.

- Remove knob and cover.
- Remove wing nut and air cleaner from base.

TO SERVICE PRE-CLEANER

- Slide foam pre-cleaner off cartridge.
- Wash it in liquid detergent and water.
- Squeeze it dry in a clean cloth. Allow it to dry.
- Saturate it in engine oil. Wrap it in clean, absorbent cloth and squeeze to remove excess oil.

TO SERVICE CARTRIDGE

- Replace a dirty, bent, or damaged cartridge.

NOTE: Do not wash the paper cartridge or use pressurized air, as this will damage the cartridge.

- Reinstall the pre-cleaner (cleaned and oiled) over the paper cartridge.
- Reassemble air cleaner, wing nut, cover and tighten knob securely.

CLEAN AIR INTAKE/COOLING AREAS

To insure proper cooling, make sure the grass screen, cooling fins, and other external surfaces of the engine are kept clean at all times.

Every 100 hours of operation (more often under extremely dusty, dirty conditions), remove the blower housing and other cooling shrouds. Clean the cooling fins and external surfaces as necessary. Make sure the cooling shrouds are reinstalled.

NOTE: Operating the engine with a blocked grass screen, dirty or plugged cooling fins, and/or cooling shrouds removed will cause engine damage due to overheating.

MUFFLER

Inspect and replace corroded muffler and spark arrester (if equipped) as it could create a fire hazard and/or damage.

SPARK PLUGS

Replace spark plugs at the beginning of each mowing season or after every 100 hours of operation, whichever occurs first. Spark plug type and gap setting are shown in "PRODUCT SPECIFICATIONS" on page 5 of this manual.

IN-LINE FUEL FILTER

The fuel filter should be replaced once each season. If fuel filter becomes clogged, obstructing fuel flow to carburetor, replacement is required.

- With engine cool, remove filter and plug fuel line sections.
- Place new fuel filter in position in fuel line with arrow pointing towards carburetor.
- Be sure there are no fuel line leaks and clamps are properly positioned.

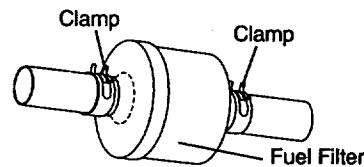

CLEANING

- Clean engine, battery, seat, finish, etc. of all foreign matter.
- Keep finished surfaces and wheels free of all gasoline, oil, etc.
- Protect painted surfaces with automotive type wax.

We do not recommend using a garden hose to clean your tractor unless the electrical system, muffler, air filter and carburetor are covered to keep water out. Water in engine can result in a shortened engine life.

SERVICE AND ADJUSTMENTS

▲ CAUTION: Before performing any service or adjustments:

- Depress clutch/brake pedal fully and set parking brake.
- Place motion control lever in neutral (N) position.
- Place attachment clutch in "DISENGAGED" position.
- Turn ignition key "OFF" and remove key.
- Make sure the blades and all moving parts have completely stopped.
- Disconnect spark plug wire from spark plug and place wire where it cannot come in contact with plug.

TO REMOVE MOWER

Mower will be easier to remove from the right side of tractor.

- Place attachment clutch in "DISENGAGED" position.
- Move attachment lift lever forward to lower mower to its lowest position.
- Roll belt off engine pulley.
- Disconnect clutch rod from clutch lever by removing retainer spring.
- Disconnect anti-swaybar from chassis bracket by removing retainer spring.
- Disconnect suspension arms from rear deck brackets by removing retainer springs.

- Disconnect front links from deck by removing retainer springs.
- Raise lift lever to raise suspension arms. Slide mower out from under tractor.

IMPORTANT: If an attachment other than the mower deck is to be mounted on the tractor, remove the front links.

TO INSTALL MOWER

- Raise attachment lift lever to its highest position.
- Slide mower under tractor with discharge guard to right side of tractor.
- Lower lift lever to its lowest position.
- Install mower in reverse order of removal instructions.

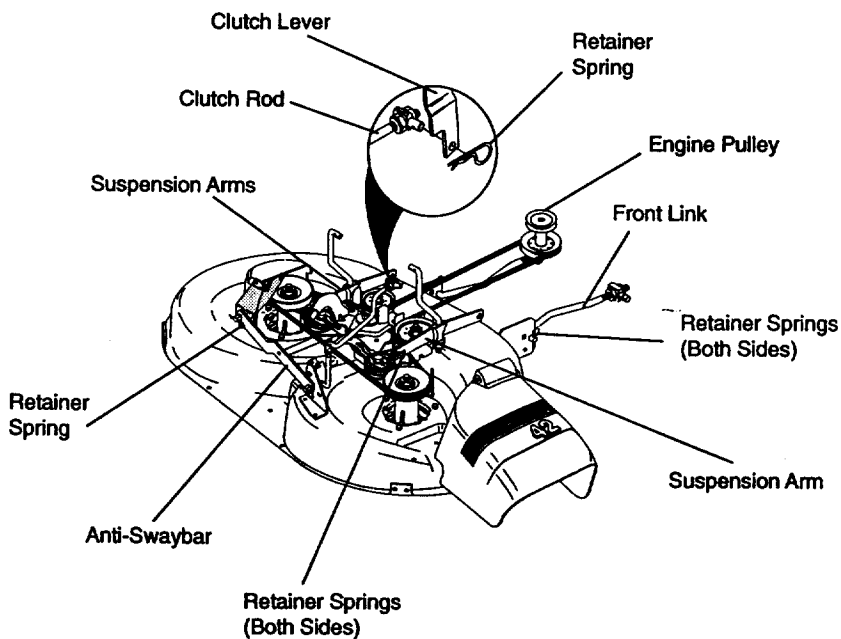

TO LEVEL MOWER HOUSING

Adjust the mower while tractor is parked on level ground or driveway. Make sure tires are properly inflated (See "PRODUCT SPECIFICATIONS"). If tires are over or underinflated, you will not properly adjust your mower.

SIDE-TO-SIDE ADJUSTMENT

- Raise mower to its highest position.
- At the midpoint of both sides of mower, measure height from bottom edge of mower to ground. Distance "A" on both sides of mower should be the same or within 1/4" of each other.
- If adjustment is necessary, make adjustment on one side of mower only.
- To raise one side of mower, tighten lift link adjustment nut on that side.
- To lower one side of mower, loosen lift link adjustment nut on that side.

NOTE: Each full turn of adjustment nut will change mower height about 1/8".

- Recheck measurements after adjusting.

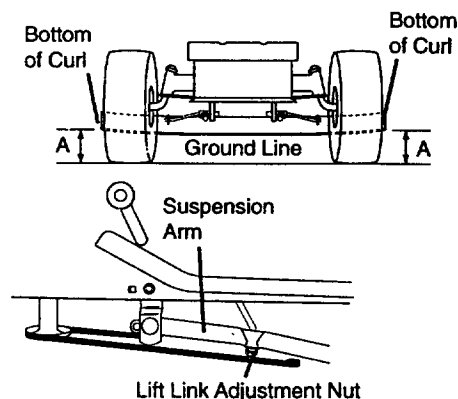

- Before making any necessary adjustments, check that both front links are equal in length. Both links should be approximately 10-3/8".
- If links are not equal in length, adjust one link to same length as other link.
- To lower front of mower loosen nut "E" on both front links an equal number of turns.
- When distance "D" is 1/8" to 1/2" lower at front than rear, tighten nuts "F" against trunnion on both front links.
- To raise front of mower, loosen nut "F" from trunnion on both front links. Tighten nut "E" on both front links an equal number of turns.
- When distance "D" is 1/8" to 1/2" lower at front than rear, tighten nut "F" against trunnion on both front links.
- Recheck side-to-side adjustment.

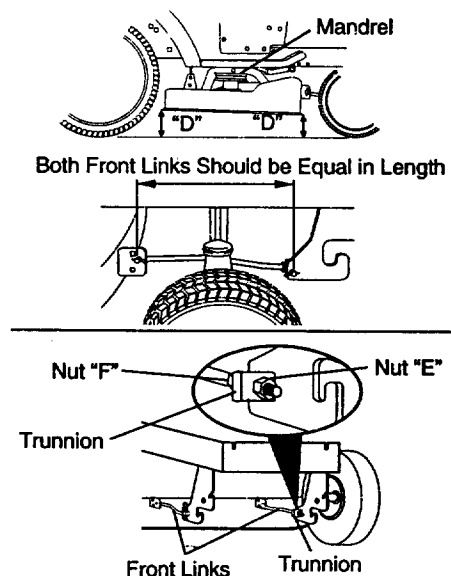

FRONT-TO-BACK ADJUSTMENT

IMPORTANT: Deck must be level side-to-side. If the following front-to-back adjustment is necessary, be sure to adjust both front links equally so mower will stay level side-to-side.

To obtain the best cutting results, the mower housing should be adjusted so that the front is approximately 1/8" to 1/2" lower than the rear when the mower is in its highest position.

Check adjustment on right side of tractor. Measure distance "D" directly in front and behind the mandrel at bottom edge of mower housing as shown.

TO REPLACE MOWER BLADE DRIVE BELT

The mower blade drive belt may be replaced without tools. Park the tractor on level surface. Engage parking brake.

BELT REMOVAL -

- Remove mower from tractor (See "TO REMOVE MOWER" in this section of this manual).
- Work belt off both mandrel pulleys and idler pulleys.
- Pull belt away from mower.

BELT INSTALLATION -

- Install new belt in reverse order of removal.
- Make sure belt is in all pulley grooves

- and inside all belt guides.
- Install mower in reverse order of removal instructions.

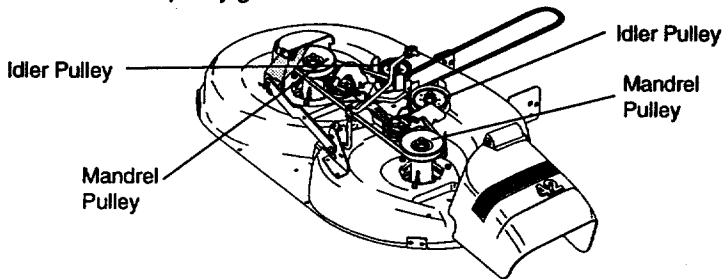

TO ADJUST BRAKE

Your tractor is equipped with an adjustable brake system which is mounted on the right side of the transaxle.

If tractor requires more than six (6) feet stopping distance at high speed in highest gear, then brake must be adjusted.

- Depress clutch/brake pedal and engage parking brake.
- Measure distance between brake operating arm and nut "A" on brake rod.
- If distance is other than 1-1/2", loosen jam nut and turn nut "A" until distance becomes 1-1/2". Retighten jam nut against nut "A".
- Road test tractor for proper stopping distance as stated above. Readjust if necessary. If stopping distance is still greater than six (6) feet in highest gear, further maintenance is necessary. Contact your nearest authorized service center/department.

- Remove belt from stationary idler and clutching idler.
- Pull belt slack toward rear of tractor. Remove belt upwards from transaxle pulley by deflecting belt keepers.
- Pull belt toward front of tractor and remove downwards from around engine pulley.
- Install new belt by reversing above procedure.

IMPORTANT: Make sure upper belt keeper is positioned properly between locator tab.

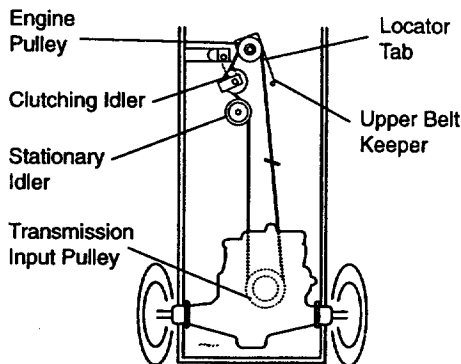

TO REPLACE MOTION DRIVE BELT

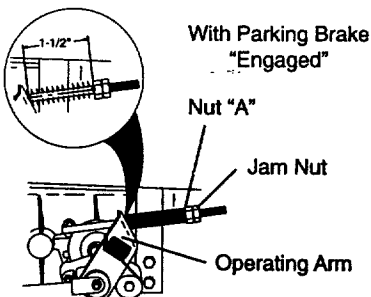

TO ADJUST STEERING WHEEL ALIGNMENT

If steering wheel crossbars are not horizontal (left to right) when wheels are positioned straight forward, remove steering wheel and reassemble per instructions in the Assembly section of this manual.

FRONT WHEEL TOE-IN/CAMBER

The front wheel toe-in and camber are not adjustable on your tractor. If damage has occurred to affect the front wheel toe-in or camber, contact your nearest authorized service center.

Park the tractor on level surface. Engage parking brake. For assistance, there is a belt installation guide decal on bottom side of left footrest.

- Remove mower (See "TO REMOVE MOWER" in this section of this manual.)
- Remove upper belt keeper.

TO REMOVE WHEEL FOR REPAIRS

- Block up axle securely.
- Remove axle cover, retaining ring and washers to allow wheel removal (rear wheel contains a square key - Do not lose).
- Repair tire and reassemble.
- On rear wheels only: align grooves in rear wheel hub and axle. Insert square key.
- Replace washers and snap retaining ring securely in axle groove.
- Replace axle cover.

NOTE: To seal tire punctures and prevent flat tires due to slow leaks, tire sealant may be purchased from your local parts dealer. Tire sealant also prevents tire dry rot and corrosion.

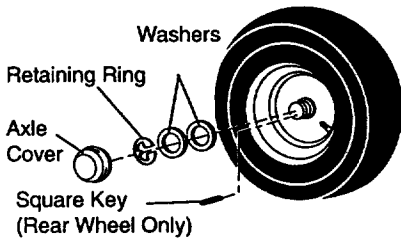

TO START ENGINE THAT HAS A WEAK BATTERY

CAUTION: Lead-acid batteries generate explosive gases. Keep sparks, flame and smoking materials away from batteries. Always wear eye protection when around batteries.

If your battery is too weak to start the engine, it should be recharged. If "jumper cables" are used for emergency starting, follow this procedure:

IMPORTANT: Your tractor is equipped with a 12 volt negative grounded system. The other vehicle must also be a 12 volt negative grounded system. Do not use your tractor battery to start other vehicles.

TO ATTACH JUMPER CABLES -

- Connect each end of the RED cable to the POSITIVE (+) terminal of each battery, taking care not to short against chassis.
- Connect one end of the BLACK cable to the NEGATIVE (-) terminal of fully charged battery.
- Connect the other end of the BLACK cable to good CHASSIS GROUND, away from fuel tank and battery.

TO REMOVE CABLES, REVERSE ORDER -

- Remove BLACK cable first from chassis and then from the fully charged battery.
- Remove RED cable last from both batteries.

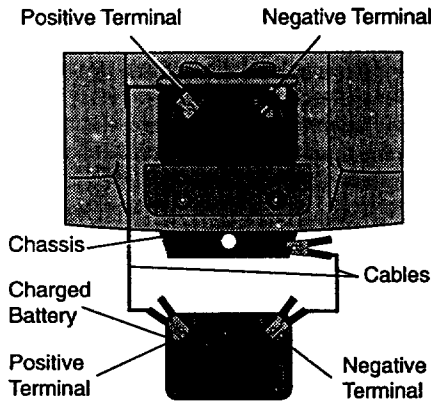

TO REPLACE HEADLIGHT BULB

- Raise hood.
- Pull bulb holder out of the hole in the backside of the grill.
- Replace bulb in holder and push bulb holder securely back into the hole in the backside of the grill.
- Close hood.

TO REMOVE HOOD AND GRILL ASSEMBLY

- Raise hood.
- Unsnap headlight wire connector.
- Stand in front of tractor. Grasp hood at sides, tilt toward engine and lift off of tractor.
- To replace, reverse above procedures.

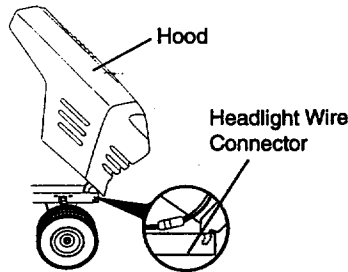

INTERLOCKS AND RELAYS

Loose or damaged wiring may cause your tractor to run poorly, stop running, or prevent it from starting.

- Check wiring. See electrical wiring diagram in the Repair Parts section of this manual.

TO REPLACE FUSE

Replace with 30 amp automotive-type plug-in fuse. The fuse holder is located behind the dash.

ENGINE

TO ADJUST THROTTLE CONTROL CABLE

The throttle control has been preset at the factory and adjustment should not be necessary. Check adjustment as described below before loosening cable. If adjustment is necessary, proceed as follows:

- With engine not running, move throttle control lever from slow to choke position. Slowly move lever from choke to fast position.
- Check to see if hole in throttle lever and hole in speed control bracket are aligned.
- If holes are not aligned, loosen cable clamp screw and align the holes by inserting a pencil or a 1/4" drill bit through both holes.
- Pull throttle cable up to remove slack and tighten cable clamp screw. Remove alignment pencil or drill bit.

TO ADJUST CARBURETOR

The carburetor has been preset at the factory and adjustment should not be necessary. However, minor adjustment may be required to compensate for differences in fuel, temperature, altitude or load. If the carburetor does need adjustment, proceed as follows:

In general, turning the adjusting needles in (clockwise) decreases the supply of fuel to the engine giving a leaner fuel/air mixture. Turning the adjusting needles out (counterclockwise) increases the supply of fuel to the engine giving a richer fuel/air mixture.

IMPORTANT: Damage to the needles and the seats in carburetor may result if needle is turned in too tight.

NOTE: The carburetor on this engine is low emission. It is equipped with an idle fuel adjusting needle with a limiter cap, which allows some adjustment within the limits allowed by the cap. Do not attempt to remove the limiter cap. The limiter cap cannot be removed without breaking the adjusting needle.

- Be sure you have a clean air filter and the throttle control cable is adjusted properly (see above).
- Start engine and allow to warm for five

minutes. Make adjustments with engine running and shift/motion control lever in neutral (N) position.

- Idle speed setting - With throttle control lever in slow position, engine should idle at 1750 RPM. If engine idles too slow or fast, turn idle speed adjusting screw in or out until correct idle is attained.
- Idle fuel needle setting - With throttle control lever in slow position, turn idle fuel adjustment needle in (clockwise) until engine begins to die and then turn out (counterclockwise) until engine runs rough. Turn needle to a point midway between those two positions.
- Recheck idle speed. Readjust if necessary.

ACCELERATION TEST -

- Move throttle control lever from slow to fast position. If engine hesitates or dies, turn idle fuel adjusting needle out (counterclockwise) 1/8 turn. Repeat test and continue to adjust, if necessary, until engine accelerates smoothly.

High speed stop is factory adjusted. Do not adjust - damage may result.

IMPORTANT: Never tamper with the engine governor, which is factory set for proper engine speed. Overspeeding the engine above the factory high speed setting can be dangerous. If you think the engine-governed high speed needs adjusting, contact your nearest AUTHORIZED service center/department, which has proper equipment and experience to make any necessary adjustments.

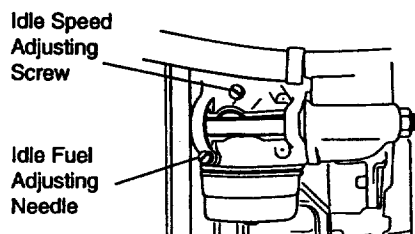
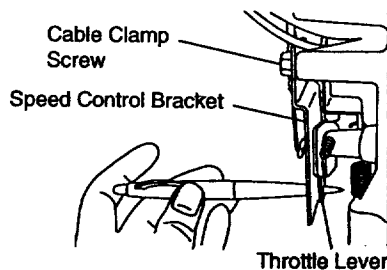

STORAGE

Immediately prepare your tractor for storage at the end of the season or if the tractor will not be used for 30 days or more.

▲CAUTION: Never store the tractor with gasoline in the tank inside a building where fumes may reach an open flame or spark. Allow the engine to cool before storing in any enclosure.

TRACTOR

Remove mower from tractor for winter storage. This will allow you to clean it thoroughly. Remove all dirt, grease, leaves, etc. Store in a clean, dry area.

- Clean entire tractor (See "CLEANING" in the Maintenance section of this manual).
- Inspect and replace belts, if necessary (See belt replacement instructions in the Service and Adjustments section of this manual).
- Lubricate as shown in the Maintenance section of this manual.
- Be sure that all nuts, bolts and screws are securely fastened. Inspect moving parts for damage, breakage and wear. Replace if necessary.
- Touch up all rusted or chipped paint surfaces; sand lightly before painting.

BATTERY

- Fully charge the battery for storage.
- After a period of time in storage, battery may require recharging.
- To help prevent corrosion and power leakage during long periods of storage, battery cables should be disconnected and battery cleaned thoroughly (see "TO CLEAN BATTERY AND TERMINALS" in the Maintenance section of this manual).
- After cleaning, leave cables disconnected and place cables where they cannot come in contact with battery terminals.
- If battery is removed from tractor for storage, do not store battery directly on concrete or damp surfaces.

ENGINE

FUEL SYSTEM

IMPORTANT: It is important to prevent gum deposits from forming in essential fuel system parts such as carburetor, fuel filter, fuel hose or tank during storage. Also, experience indicates that alcohol

blended fuels (called gasohol or using ethanol or methanol) can attract moisture which leads to separation and formation of acids during storage. Acidic gas can damage the fuel system of an engine while in storage.

- Drain the fuel tank.
- Start the engine and let it run until the fuel lines and carburetor are empty.
- Never use engine or carburetor cleaner products in the fuel tank or permanent damage may occur.
- Use fresh fuel next season.

NOTE: Fuel stabilizer is an acceptable alternative in minimizing the formation of fuel gum deposits during storage. Add stabilizer to gasoline in fuel tank or storage container. Always follow the mix ratio found on stabilizer container. Run engine at least 10 minutes after adding stabilizer to allow the stabilizer to reach the carburetor. Do not drain the gas tank and carburetor if using fuel stabilizer.

ENGINE OIL

Drain oil (with engine warm) and replace with clean engine oil. (See "ENGINE" in the Maintenance section of this manual).

CYLINDERS

- Remove spark plug(s).
- Pour one ounce of oil through spark plug hole(s) into cylinder(s).
- Turn ignition key to "START" position for a few seconds to distribute oil.
- Replace with new spark plug(s).

OTHER

- Do not store gasoline from one season to another.
- Replace your gasoline can if it starts to rust. Rust and/or dirt in your gasoline will cause problems.
- If possible, store your tractor indoors and cover it to give protection from dust and dirt.
- Cover your tractor with a suitable protective cover that does not retain moisture. Do not use plastic. Plastic cannot breathe, which allows condensation to form and cause your tractor to rust.

IMPORTANT: Never cover tractor while engine and exhaust areas are still warm.

TROUBLESHOOTING CHART

PROBLEM	CAUSE	CORRECTION
Will not start	<ul style="list-style-type: none"> • Out of fuel. • Engine not "CHOKED" properly. • Engine flooded. • Bad spark plug. • Dirty air filter. • Dirty fuel filter. • Water in fuel. • Loose or damaged wiring. • Carburetor out of adjustment. • Engine valves out of adjustment. 	<ul style="list-style-type: none"> • Fill fuel tank. • See "TO START ENGINE" in Operation section. • Wait several minutes before attempting to start. • Replace spark plug. • Clean/replace air filter. • Replace fuel filter. • Drain fuel tank and carburetor, refill tank with fresh gasoline and replace fuel filter. • Check all wiring. • See "To Adjust Carburetor" in Service and Adjustments section. • Contact an authorized service center.
Hard to start	<ul style="list-style-type: none"> • Dirty air filter. • Bad spark plug. • Weak or dead battery. • Dirty fuel filter. • Stale or dirty fuel. • Loose or damaged wiring. • Carburetor out of adjustment. • Engine valves out of adjustment. 	<ul style="list-style-type: none"> • Clean/replace air filter. • Replace spark plug. • Recharge or replace battery. • Replace fuel filter. • Drain fuel tank and refill with fresh gasoline. • Check all wiring. • See "To Adjust Carburetor" in Service and Adjustments section. • Contact an authorized service center.
Engine will not turn over	<ul style="list-style-type: none"> • Clutch/brake pedal not depressed. • Attachment clutch is engaged. • Weak or dead battery. • Blown fuse. • Corroded battery terminals. • Loose or damaged wiring. • Faulty ignition switch. • Faulty solenoid or starter. • Faulty operator presence switch(es). 	<ul style="list-style-type: none"> • Depress clutch/brake pedal. • Disengage attachment clutch. • Recharge or replace battery. • Replace fuse. • Clean battery terminals. • Check all wiring. • Check/replace ignition switch. • Check/replace solenoid or starter. • Contact an authorized service center.
Engine clicks but will not start	<ul style="list-style-type: none"> • Weak or dead battery. • Corroded battery terminals. • Loose or damaged wiring. • Faulty solenoid or starter. 	<ul style="list-style-type: none"> • Recharge or replace battery. • Clean battery terminals. • Check all wiring. • Check/replace solenoid or starter.
Loss of power	<ul style="list-style-type: none"> • Cutting too much grass/too fast. • Throttle in "CHOKE" position. 	<ul style="list-style-type: none"> • Set in "Higher Cut" position/reduce speed. • Adjust throttle control.

TROUBLESHOOTING CHART

PROBLEM	CAUSE	CORRECTION
Loss of power (cont'd)	<ul style="list-style-type: none"> • Build-up of grass, leaves and trash under mower. • Dirty air filter. • Low oil level/dirty oil. • Faulty spark plug. • Dirty fuel filter. • Stale or dirty fuel. • Water in fuel. • Spark plug wire loose. • Dirty engine air screen/fins. • Dirty/clogged muffler. • Loose or damaged wiring. • Carburetor out of adjustment. • Engine valves out of adjustment. 	<ul style="list-style-type: none"> • Clean underside of mower housing. • Clean/replace air filter. • Check oil level/change oil. • Clean and regap or change spark plug. • Replace fuel filter. • Drain fuel tank and refill with fresh gasoline. • Drain fuel tank and carburetor, refill tank with fresh gasoline and replace fuel filter. • Connect and tighten spark plug wire. • Clean engine air screen/fins. • Clean/replace muffler. • Check all wiring. • See "To Adjust Carburetor" in Service and Adjustments section. • Contact an authorized service center.
Excessive vibration	<ul style="list-style-type: none"> • Worn, bent or loose blade. • Bent blade mandrel. • Loose/damaged part(s). 	<ul style="list-style-type: none"> • Replace blade. Tighten blade bolt. • Replace blade mandrel. • Tighten loose part(s). Replace damaged parts.
Engine continues to run when operator leaves seat with attachment clutch engaged	<ul style="list-style-type: none"> • Faulty operator-safety presence control system. 	<ul style="list-style-type: none"> • Check wiring, switches and connections. If not corrected, contact an authorized service center/department.
Poor cut - uneven	<ul style="list-style-type: none"> • Worn, bent or loose blade. • Mower deck not level. • Buildup of grass, leaves, and trash under mower. 	<ul style="list-style-type: none"> • Replace blade. Tighten blade bolt. • Level mower deck. • Clean underside of mower housing.
Poor cut - uneven (cont'd)	<ul style="list-style-type: none"> • Bent blade mandrel. • Clogged mower deck vent holes from buildup of grass, leaves, and trash around mandrels. 	<ul style="list-style-type: none"> • Replace blade mandrel. • Clean around mandrels to open vent holes.
Mower blades will not rotate	<ul style="list-style-type: none"> • Obstruction in clutch mechanism. • Worn/damaged mower drive belt. • Frozen idler pulley. • Frozen blade mandrel. 	<ul style="list-style-type: none"> • Remove obstruction. • Replace mower drive belt. • Replace idler pulley. • Replace blade mandrel.
Poor grass discharge	<ul style="list-style-type: none"> • Engine speed too slow. • Travel speed too fast. • Wet grass. 	<ul style="list-style-type: none"> • Place throttle control in "FAST" position. • Shift to slower speed. • Allow grass to dry before mowing.

TROUBLESHOOTING CHART

PROBLEM	CAUSE	CORRECTION
Poor grass discharge (cont'd)	<ul style="list-style-type: none"> • Mower deck not level. • Low/uneven tire air pressure. • Worn, bent or loose blade. • Buildup of grass, leaves and trash under mower. • Mower drive belt worn. • Blades improperly installed. • Improper blades used. • Clogged mower deck vent holes from buildup of grass, leaves, and trash around mandrels. 	<ul style="list-style-type: none"> • Level mower deck. • Check tires for proper air pressure. • Replace/sharpen blade. Tighten blade bolt. • Clean underside of mower housing. • Replace mower drive belt. • Reinstall blades sharp edge down. • Replace with blades listed in this manual. • Clean around mandrels to open vent holes.
Headlight(s) not working (if so equipped)	<ul style="list-style-type: none"> • Switch is "OFF". • Bulb(s) burned out. • Faulty light switch. • Loose or damaged wiring. • Blown fuse. 	<ul style="list-style-type: none"> • Turn switch "ON". • Replace bulb(s). • Check/replace light switch. • Check wiring and connections. • Replace fuse.
Battery will not charge	<ul style="list-style-type: none"> • Bad battery cell(s). • Poor cable connections. • Faulty regulator (if so equipped). • Faulty alternator. 	<ul style="list-style-type: none"> • Replace battery. • Check/clean all connections. • Replace regulator. • Replace alternator.
Loss of drive	<ul style="list-style-type: none"> • Freewheel control in "disengaged" position. • Motion drive belt worn, damaged or broken. • Air trapped in transmission during shipment or servicing. 	<ul style="list-style-type: none"> • Place freewheel control in "engaged" position. • Replace motion drive belt. • Purge transmission.
Engine "backfires" when turning engine "OFF"	<ul style="list-style-type: none"> • Engine throttle control not set at "SLOW" position for 30 seconds before stopping engine. 	<ul style="list-style-type: none"> • Move throttle control to "SLOW" position and allow to idle for 30 seconds before stopping engine.

TRACTOR -- MODEL NUMBER 917.270720

SCHEMATIC

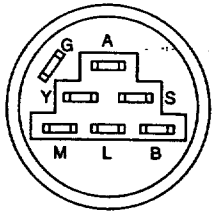
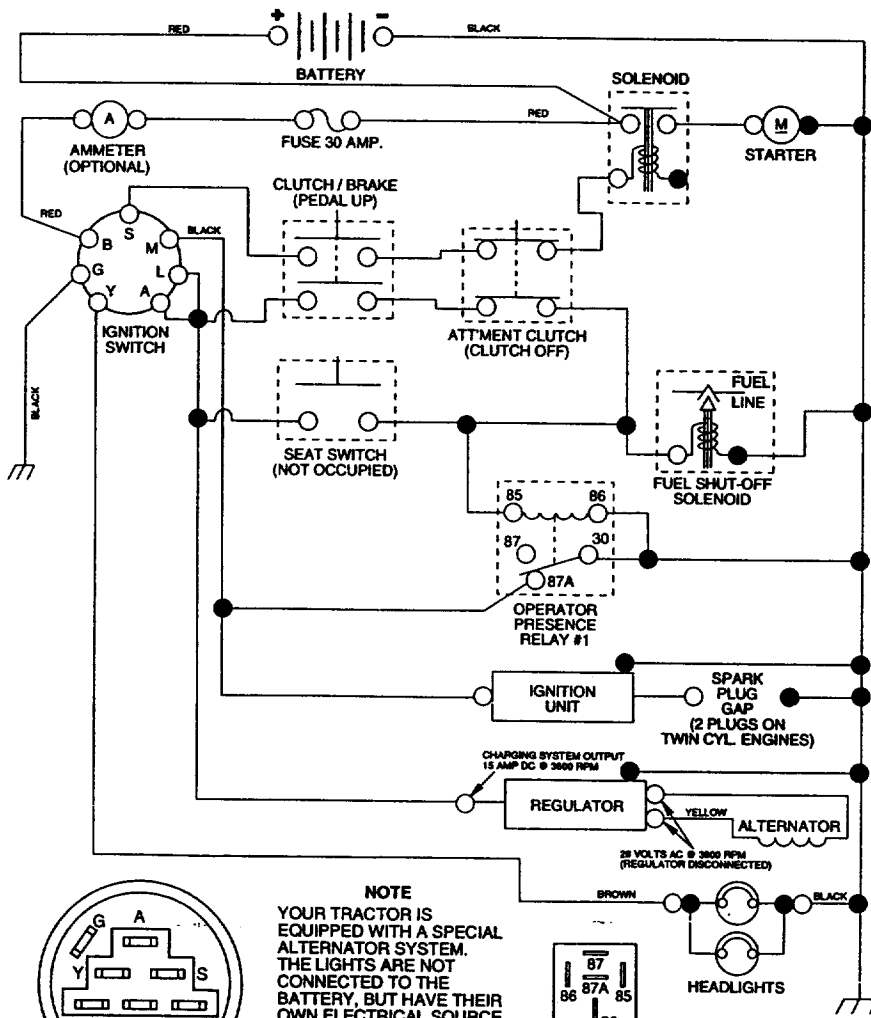

IGNITION SWITCH

POSITION	CIRCUIT	"MAKE"
OFF	G + M + L	NONE
RUNLIGHT	B + L	A + Y
RUN	B + L	NONE
START	B + L + S	NONE

NOTE
YOUR TRACTOR IS EQUIPPED WITH A SPECIAL ALTERNATOR SYSTEM. THE LIGHTS ARE NOT CONNECTED TO THE BATTERY, BUT HAVE THEIR OWN ELECTRICAL SOURCE. BECAUSE OF THIS, THE BRIGHTNESS OF THE LIGHTS WILL CHANGE WITH ENGINE SPEED. AT IDLE THE LIGHTS WILL DIM, AS THE ENGINE IS SPEEDED UP, THE LIGHTS WILL BECOME THEIR BRIGHTEST.

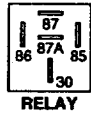

RELAY

NON-REMOVABLE CONNECTIONS REMOVABLE CONNECTIONS

WIRING INSULATED CLIPS
NOTE: IF WIRING INSULATED CLIPS WERE REMOVED FOR SERVICING OF UNIT, THEY SHOULD BE REPLACED TO PROPERLY SECURE YOUR WIRING.

REPAIR PARTS

TRACTOR -- MODEL NUMBER 917.271110

ELECTRICAL

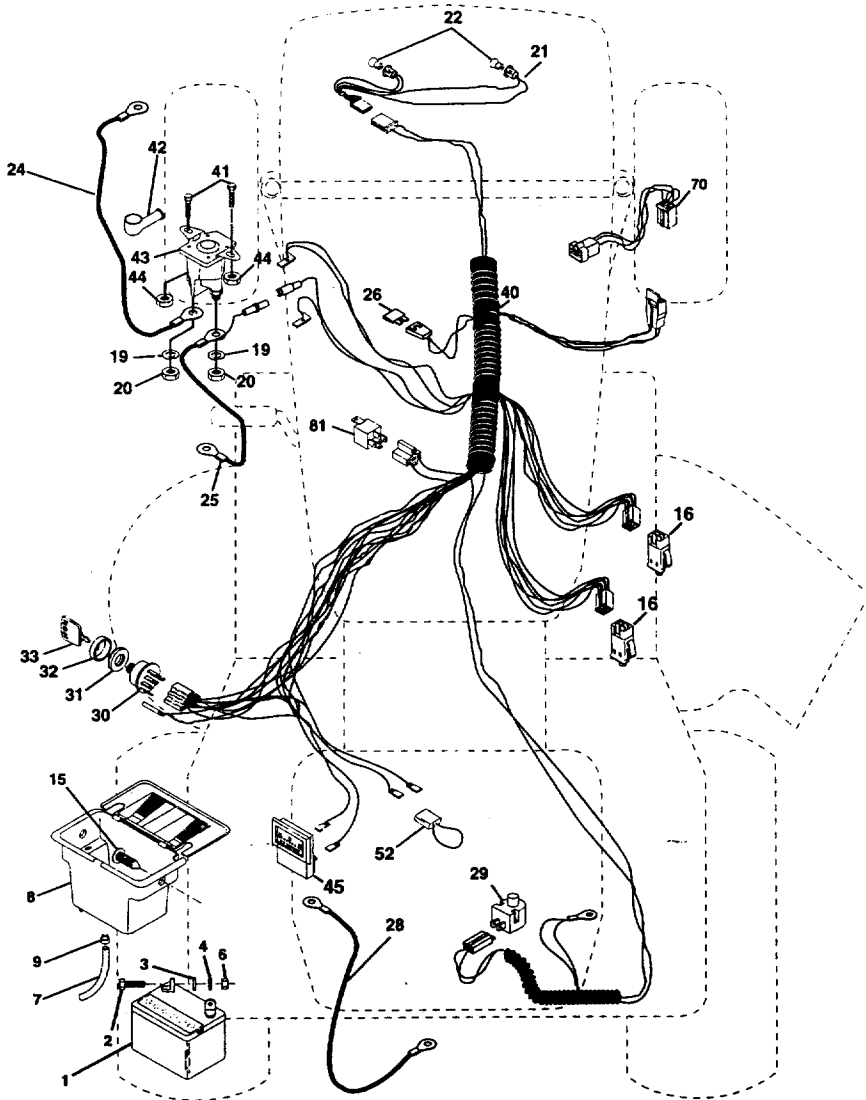

TRACTOR - - MODEL NUMBER 917.271110

ELECTRICAL

KEY NO.	PART NO.	DESCRIPTION
1	163465	Battery,12 Volt 28 Amp
2	74760412	Bolt, Hex 1/4-20 x 3/4
3	STD551025	Washer 9/32 x 5/8 x 16 Gauge
4	STD551125	Washer, Lock 1/4
6	STD541025	Nut, Hex 1/4-20
8	156417	Case, Battery Mech Hinge
16	161343	Switch, Interlock N. OPN./N.OPN
19	STD551125	Washer, Lock 1/4
20	73350400	Nut, Hex, Jam 1/4-20 UNC
21	147430	Harness, Light Socket (w/4152J)
22	4152J	Light Bulb
24	4799J	Cable, Battery, 6 Gauge, Red, 11"
25	146147	Cable, Battery, 6 Gauge, Red, W16 Wire
26	108824X	Fuse, 30 Amp
28	4207J	Cable, Ground, 6 Gauge, Black, 12"
29	160784	Switch, Plunger Normal OP Olive
30	140301	Switch, Ignition 4 Position
31	124211X	Nut, Ignition
32	141226	Cover, Ignition Switch
33	109310X	Key, Molded, Craftsman
40	161351	Harness, Ignition
41	71110408	Bolt Blk Fin Hex 1/4-20 UNC x 1/2
42	131563	Cover, Terminal
43	145673	Solenoid
44	73640400	Nut,Keps Blk Hex 1/4-20 UNC
45	122822X	Ammeter, Rectangular 15 Amp
52141940		Protection Wire Loop (Hour Meter)
70	140426	Harness, Engine Kohl Cmd-L 15AR
81	109748X	Relay Asm.

NOTE: All component dimensions given in U.S. inches
1 inch = 25.4 mm

TRACTOR -- MODEL NUMBER 917.271110

CHASSIS AND ENCLOSURES

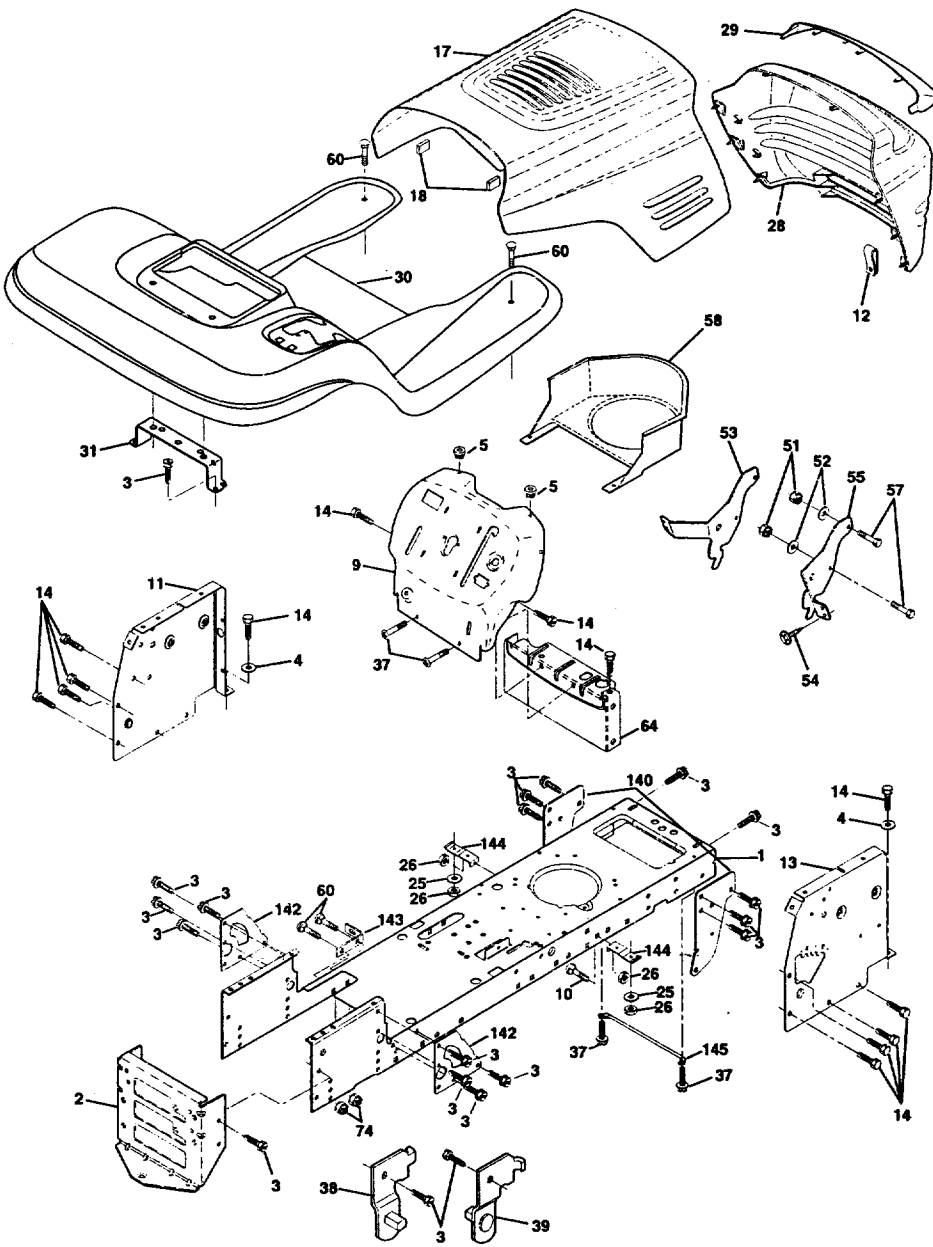

TRACTOR -- MODEL NUMBER 917.271110

CHASSIS AND ENCLOSURES

KEY NO.	PART NO.	DESCRIPTION
1	160392	Chassis Assembly
2	140356	Drawbar
3	17490612	Screw, Thd., Roll. 3/8-16 x 3/4
4	19131216	Washer 13/32 x 3/4 x 16 Gauge
5	155272	Bumper Hood/Dash
9	161917X013	Dash
10	STD533710	Bolt, Carriage 3/8-16 x 3/4
11	155927	Panel, Dash, LH
12	145660	Clip Tinnerman Grille P/L
13	155936	Panel, Dash, RH
14	17490608	Screw, Thd., Roll. 3/8-16 x 1/2
17	144983X558	Hood Assembly
18	126938X	Bumber Hood
25	19131312	Washer 13/32 x 13/16 x 12 Gauge
26	STD541437	Locknut
28	145198X558	Grille w/Clips MS-558
29	155217	Lens, Grille
30	151287X558	Fender/Footrest Pnt STLT N Hold 558
31	139976	Bracket, Fender/Support
37	17490508	Screw Thdrol 5/16-18 x 1/2
38	139886	Pivot Bracket Assembly, LH,
39	139887	Pivot Bracket Assembly, RH,
51	73800400	Nut Lock w/Insert 1/4 - 20 UNC
52	19091416	Washer, 9/32 x 7/8 x 16 Gauge
53	145201	Bracket, Grille Pickoff LH
54	161464	Screw, Hex Wshd #8-18 x 7/8
55	145202	Bracket, Grille Pickoff RH
57	STD552507	Bolt, FinHex 1/4 -20 UNC x .75
58	150127	Duct, Air Engine PL/LT
60	STD533707	Bolt, Rdhd Sqnk 3/8-16 UNC x 3/4
64	154798	Dash, Lower STLT
74	STD541437	Nut, Crownlock 3/8-16 UNC
140	158418	Bracket, Suspension Front
142	156095	Plate, Reinforcement STLT
143	154966	Backrest, Swaybar Chassis
144	154207	Bracket, Footrest STLT
145	156524	Rod Pivot Chassis/Hood
--	5479J	Plug, Button

NOTE: All component dimensions given in U.S. inches
1 inch = 25.4 mm

TRACTOR -- MODEL NUMBER 917.271110

GROUND DRIVE

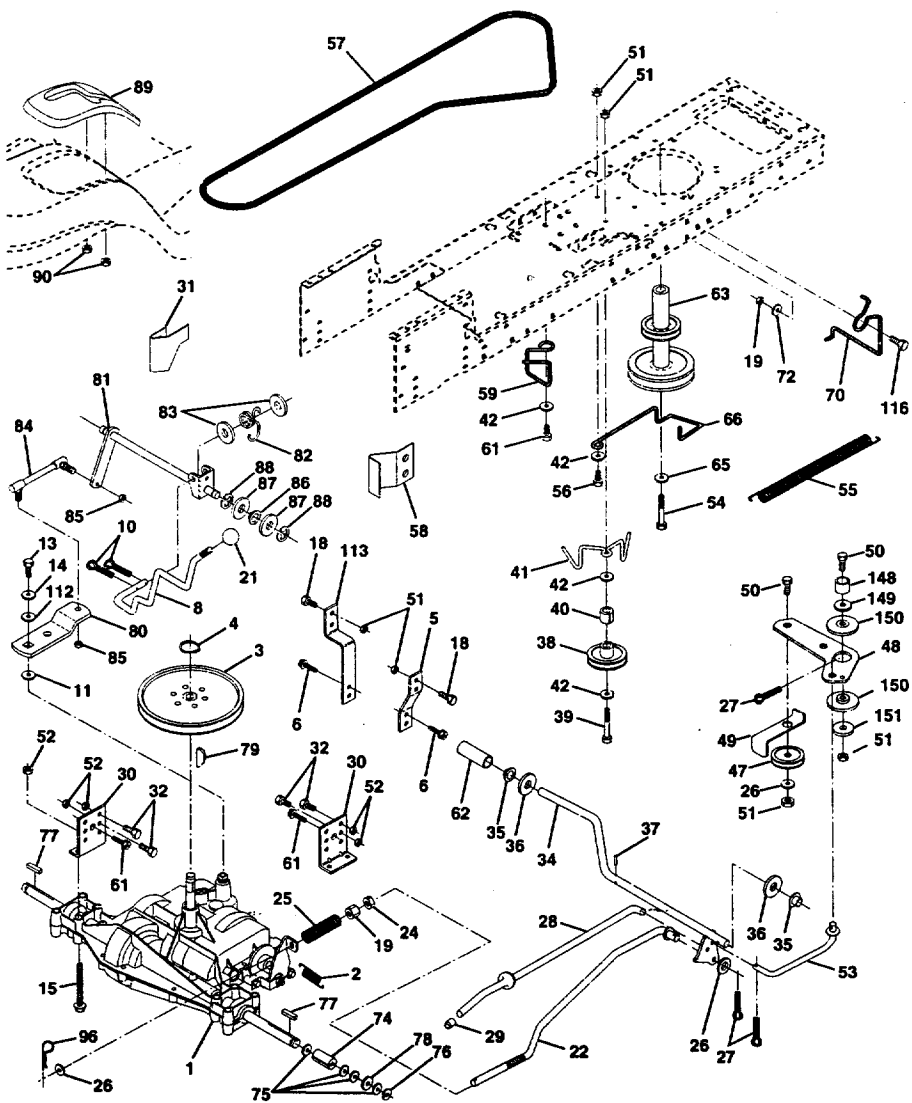

TRACTOR -- MODEL NUMBER 917.271110

GROUND DRIVE

KEY NO.	PART NO.	DESCRIPTION	KEY NO.	PART NO.	DESCRIPTION
1	161451	Transaxle(See Breakdown) Dana, Model Number 4360-122	52	STD541431	Nut Crown Lock 5/16-18 UNC
2	146682	Spring, Return, Brake	53	105710X	Link, Clutch
3	123666X	Pulley, Transaxle	55	105709X	Spring, Clutch Return
4	12000028	Ring, Retainer	56	STD523712	Bolt Fin Hex 3/8-16 x 1-1/4
5	121520X	Strap, Torque	57	160855	V-Belt, Ground Drive
6	17490512	Screw, Thd., Roll. 5/16-18 x 3/4	58	127274X	Keeper, Belt, R.H.
8	154792	Rod Shifter Fender STLT	59	140312	Keeper, Belt, Center Span
10	STD561210	Pin, Cotter	61	17490612	Screw, Thd., Roll. 3/8-16 x 3/4
11	105701X	Washer, Shift Plate	62	8883R	Cover, Pedal
13	74550412	Bolt 1/4-28 UNF W/Patch Grade 8	63	140186	Pulley, Engine
14	STD551125	Washer	64	71170764	Bolt, Hex Head, Fin. 7/16-20 x 4 Grade 5
15	74490544	Bolt, Hex Flghd 5/16-18 Grade 5	65	STD551143	Washer
18	STD523710	Bolt Fin Hex 3/8-16 UNC x 1. Gr 5	66	154778	Keeper, Belt, Engine, Fool- Proof
19	STD541437	Nut	70	134683	Guide, Mower Drive Belt, R.H.
21	106933X	Knob	72	19132012	Washer 13/32 x 1-1/4 x 12 Gauge
22	130804	Rod, Brake	74	109502X	Spacer, Split
24	STD541237	Nut	75	121749X	Washer 25/32 x 1-1/4 x 16 Gauge
25	106888X	Spring, Brake Rod	76	STD581075	E-Ring
26	STD551037	Washer	77	123583X	Key, Square 2.0 x .1845/.1865
27	STD561210	Pin	78	121748X	Washer 25/32 x 1-5/8 x 16 Gauge
28	145204	Rod, Parking Brake	80	160783	Arm, Shift
29	124236X	Cap, Parking Brake, Red	81	161077	Shaft Assembly
30	130807	Bracket, Transaxle	82	123782X	Spring, Torsion
31	127275X	Keeper, Belt, L.H.	83	19171216	Washer 17/32 x 3/4 x 16 Gauge
32	STD523107	Bolt	84	145643	Tie Rod
34	155071	Shaft Assembly, Foot Pedal	85	150360	Nut, Nylock
35	120183X	Bearing, Nylon	86	157480	Bushing
36	STD551062	Washer	87	19212016	Washer
37	STD571810	Roll Pin	88	12000008	E-Ring
38	123674X	Pulley, Idler, Flat	89	158391	Console, Shift, STLT
39	STD523727	Bolt	90	124346X	Nut, Self-Threading, Washer Hd 1/4
40	4470J	Spacer, Split .395 x .59	112	19091210	Washer 9/32 x 3/4 x 10 Gauge
41	154777	Keeper, Belt, Idler Fool-Proof	116	72110610	Bolt Rdhd Sqneck 3/8-16 x 1.25
42	19131312	Washer 13/32 x 13/16 x 12 Gauge	148	159103	Spacer
47	127783	Pulley, Idler, V-Groove, Plastic	149	122052X	Spacer Retainer Pm Mower
48	154407	Bellcrank Clutch Grnd Drv Stl	150	150935	Bushing Nylon Collared
49	123205X	Retainer, Belt	151	19133210	Washer 13/32 x 2 x 10 Ga.
50	STD523715	Bolt			
51	STD541437	Nut Crown Lock 3/8-16 UNC			

NOTE: All component dimensions given in U.S. inches
1 inch = 25.4 mm

TRACTOR -- MODEL NUMBER 917.271110
STEERING ASSEMBLY

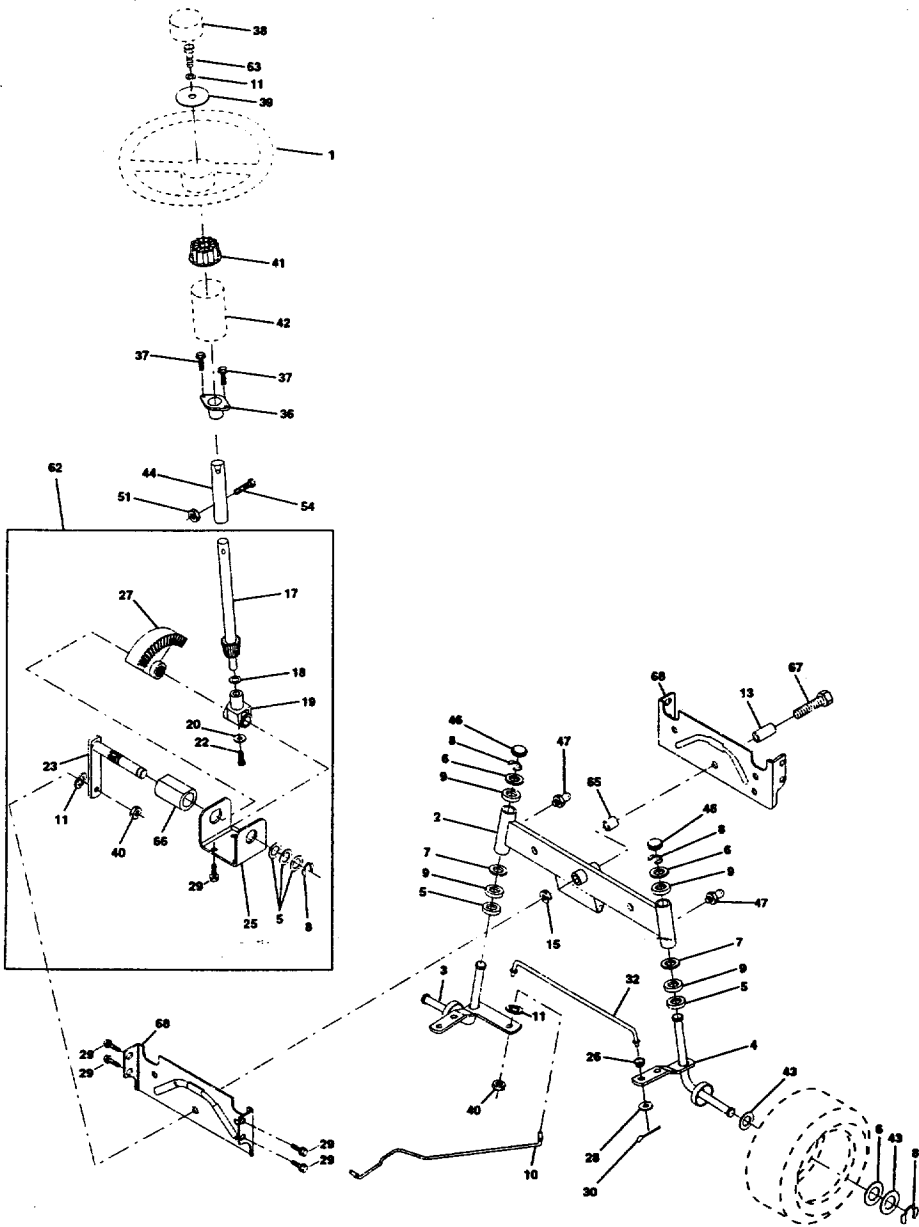

TRACTOR -- MODEL NUMBER 917.271110

STEERING ASSEMBLY

KEY NO.	PART NO.	DESCRIPTION
1	139768	Wheel, Steering
2	154427	Axle, Asm Front
3	156483	Spindle, Asm Lh
4	157473	Spindle, Asm Rh
5	6266H	Bearing, Race Thrust Harden
6	121748X	Washer, 25/32 x 1 5/8 x 16ga
7	19272016	Washer, 27/32 x 1 1/4 x 16 Ga
8	12000029	Ring, Klip #15304-75
9	3366R	Bearing, Col Strg Blk
10	156438	Draglink, Extended Stamped
11	STD551137	Washer, Lock Hvy Hicl Spr 3/8
13	154779	Bearing, Axle STLT/GT
15	73901000	Locknut, Flange 5/8-11 UNC
17	156546	Shaft, Asm Strg Private Label
18	57079	Washer, Thrust 515 x 750 x 033
19	124035X	Support, Shaft
20	126684X	Washer, Shim 1/4 x 5/8 x 062
22	71200410	Screw, Hex Socket Hd 1/4-20 x 5/8
23	127501	Shaft, Asm Pittman
25	154406	Bracket, Steering
26	126847X	Bushing, Rod Tie Blk Lt
27	136874	Gear, Sector
28	19131416	Washer, 13/32 x 7/8 x 16ga
29	17490612	Screw, Thdrol 3/8-16x3/4 Ty-tt
30	STD561210	Pin, Cotter 1/8 x 3/4 Cad
32	130465	Rod, Tie Wire Form 19 75 Mech
36	155099	Bushing, Strg 5/8 Id Dash
37	152927	Screw, TT #10-32 x 5 x 3/8 Flange
38	139769	Insert, Steering Wheel
39	19133808	Washer, 13/32 x 2-3/8 x 8 Gauge
40	STD541537	Gripco Nut
41	100711L	Adaptor, Wheel Strg
42	145054	Boot Shaft Steering
43	121749X	Washer, 25/32 x 1-1/4 x 16 Gauge
44	153720	Extension, Steering Non-Adjust
46	121232X	Cap, Spindle Fr Top Blk
47	6855M	Fitting, Grease
51	STD541431	Nut Lock Hex w/Ins 5/16 -18 UNC
54	74780520	Bolt Fin Hex 5/16 - 18 UNC x 1 -1/4
62	156594	Kit, Steering Assembly
63	STD523710	Bolt, Fin Hex 3/8-16 UNC x 1 Gr. 5
65	154780	Spacer, Axle
66	154404	Bearing, Arm Pittman
67	74781044	Bolt, Fin Hex 5/8-11 UNC x 2-3/4
68	154429	Axle, Brace

NOTE: All component dimensions given in U.S. inches
1 inch = 25.4 mm

TRACTOR - - MODEL NUMBER 917.271110

ENGINE

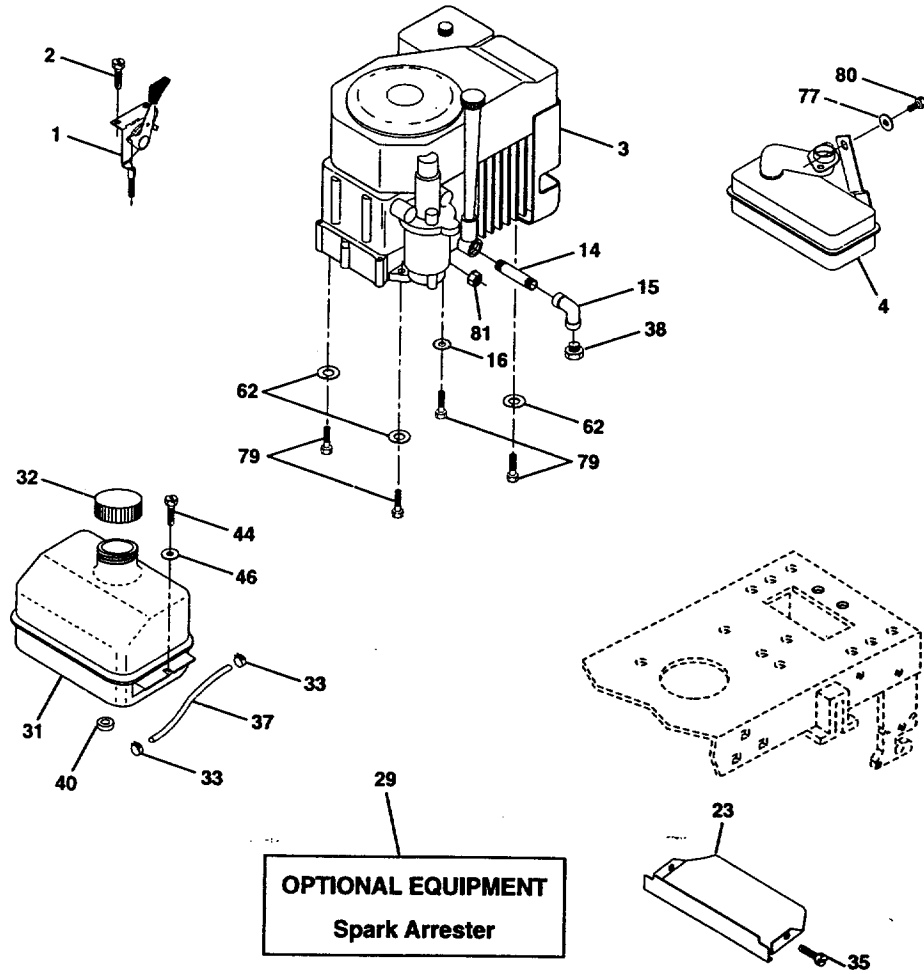

TRACTOR - - MODEL NUMBER 917.271110

ENGINE

KEY NO.	PART NO.	DESCRIPTION
1	162156	Control, Throt 1 Ch
2	17720410	Screw, Hex Thd Cut 1/4-20x5/8 T
3	-----	Engine (See Breakdown) Kohler Model No. CV16-43513
4	159420	Muffler
14	13280328	Nipple, Pipe 3/8 NPT x 3-1/2
15	13200300	Elbow, Std 90 Degree 3/8-18 Npt
16	STD551231	Washer
23	159880	Shield, BRNDBR Guard
29	137180	Arrestor, Spark
31	109202X	Tank, Fuel
32	158990	Cap Assembly, Fuel Tank, Vented
33	123487X	Clamp, Hose Blk
35	17490512	Screw, Thdrol 5/16-18 x 3/4 TYT
37	137040	Line Fuel
38	-----	Plug Oil Drain (Order From Engine Manufacturer)
40	124028X	Bushing, Snap, Fuel Line
44	17490412	Screw, Hex Washer Head, Thd. Roll. 1/4-20 x 3/4
46	19091416	Washer, 9/32 x 7/8 x 16 Gauge
62	STD551131	Washer, Lock
77	19101216	Washer 5/16 x 3/4 x 16 Gauge
79	M740108025	Bolt, Hex
80	74760508	Bolt, Hex Hd 5/16-18 UNC x 1/2
81	128861	Nut, Flange 1/4-20 Starter Nut

NOTE: All component dimensions given in U.S. inches
1 inch = 25.4 mm

TRACTOR -- MODEL NUMBER 917.271110

SEAT ASSEMBLY

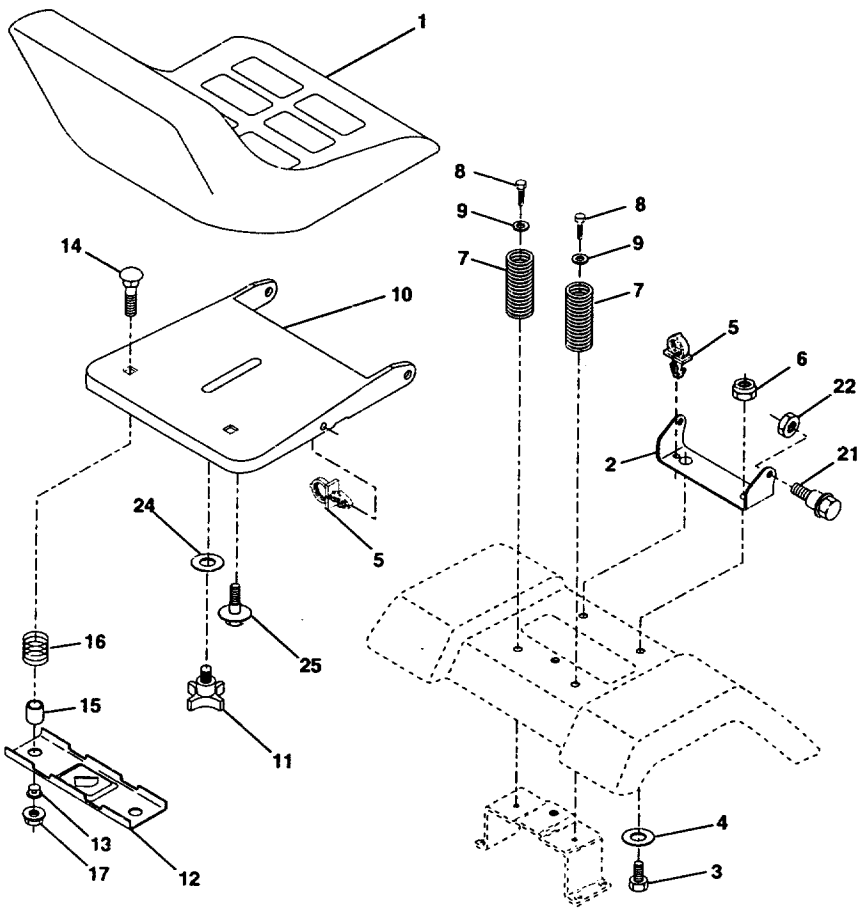

KEY NO.	PART NO.	DESCRIPTION
1	140122	Seat 3350 Blk/blk Craftsman
2	140551	Bracket Pnt Pivot Seat (blk)
3	STD523710	Bolt Fin Hex 3/8-16unc X 1
4	19131610	Washer 13/32 X 3/4 X 10 Ga
5	145006	Clip Push In Hinged
6	STD541437	Nut Hex Lock w/Ins 3/8-16 Unc
7	124181X	Spring Seat Cprsn 2 250 Blk Zi
8	17490616	Screw Thdrol 3/8-16 X 1 Ty-tt
9	19131614	Washer 13/32 X 1 X 14 Ga
10	155925	Pan Pnt Seat (blk)
11	120068X	Knob Seat 1/2-13 Unc Blk

KEY NO.	PART NO.	DESCRIPTION
12	121246X	Bracket Pnt Mounting Switch
13	121248X	Bushing Snap Blk Nyl 50 Id
14	72050412	Bolt Rdhd Sht Nk 1/4-20x1-1/2
15	134300	Spacer Split 28 X 96 Zinc
16	121250X	Spring Cprsn 1 27 Blk Pnt
17	123976X	Nut Lock 1/4 Lge Fig Gr 5 Zinc
21	153236	Bolt Shoulder 5/16-18 Unc-2A
22	STD541431	Nut Hex Lock w/Ins 5/16-18
24	19171912	Washer 17/32 X 1-3/16 X 12 Ga.
25	127018X	Bolt Shoulder 5/16-18 X 62

NOTE: All component dimensions given in U.S. inches
1 inch = 25.4 mm

TRACTOR -- MODEL NUMBER 917.271110

DECALS

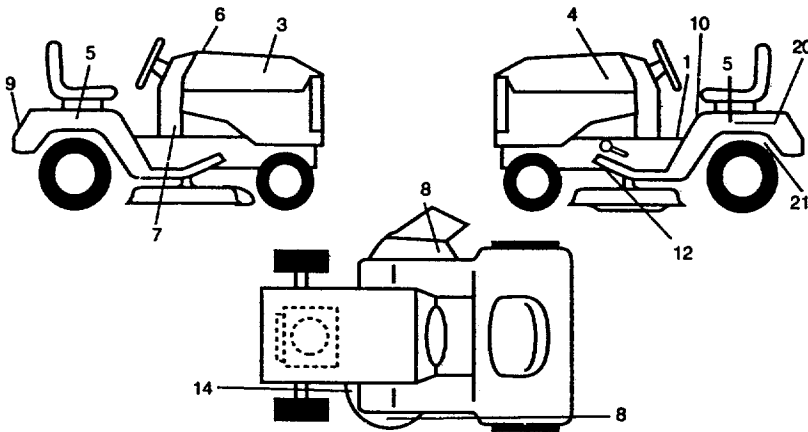

KEY NO.	PART NO.	DESCRIPTION	KEY NO.	PART NO.	DESCRIPTION
1	156368	Decal, Oper. Instr.	10	156439	Decal, Fender Danger
3	163200	Decal, Hood, R.H.	12	146046	Decal, V-Belt Drive Schematic
4	163202	Decal, Hood, L.H.	14	160396	Decal, V-Belt Schematic
5	163207	Decal, Fender Sd White Rad/6sp 42"	20	149516	Decal Battery Dngr/Psn Eng
6	133644	Decal, Customer Maintenance	21	138047	Decal, Battery Diehard Sears
7	163263	Decal, Dash Pnl Kohler 16.5 Ohv	--	138311	Decal, Lift Handle
8	163203	Decal, Deck EZ3/Mulch Srs	--	154515	Pad Footrest LH STL
9	163204	Decal, Fender, Craftsman	--	154516	Pad Footrest RH STL
			--	163484	Owner's Manual, English
			--	163485	Owner's Manual, Spanish

WHEELS & TIRES

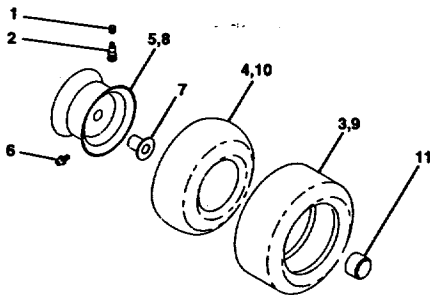

KEY NO.	PART NO.	DESCRIPTION
1	59192	Cap Valve Tire
2	65139	Stem Valve
3	106222X	Tire Front
4	59904	Tube Front Tire (Not Provided, Service Item Only)
5	106732X427	Rim Front
6	278H	Fitting Grease (Front Wheel Only)
7	9040H	Bearing Flange (Front Wheel Only)
8	106108X427	Rim Rear
9	122082X	Tire Rear
10	7152J	Tube Rear Tire (Not Provided, Service Item Only)
11	104757X	Cap Axle
--	144334	Sealant, Tire (10 oz. tube)

NOTE: All component dimensions given in U.S. inches
1 inch = 25.4 mm

TRACTOR - - MODEL NUMBER 917.271110

LIFT ASSEMBLY

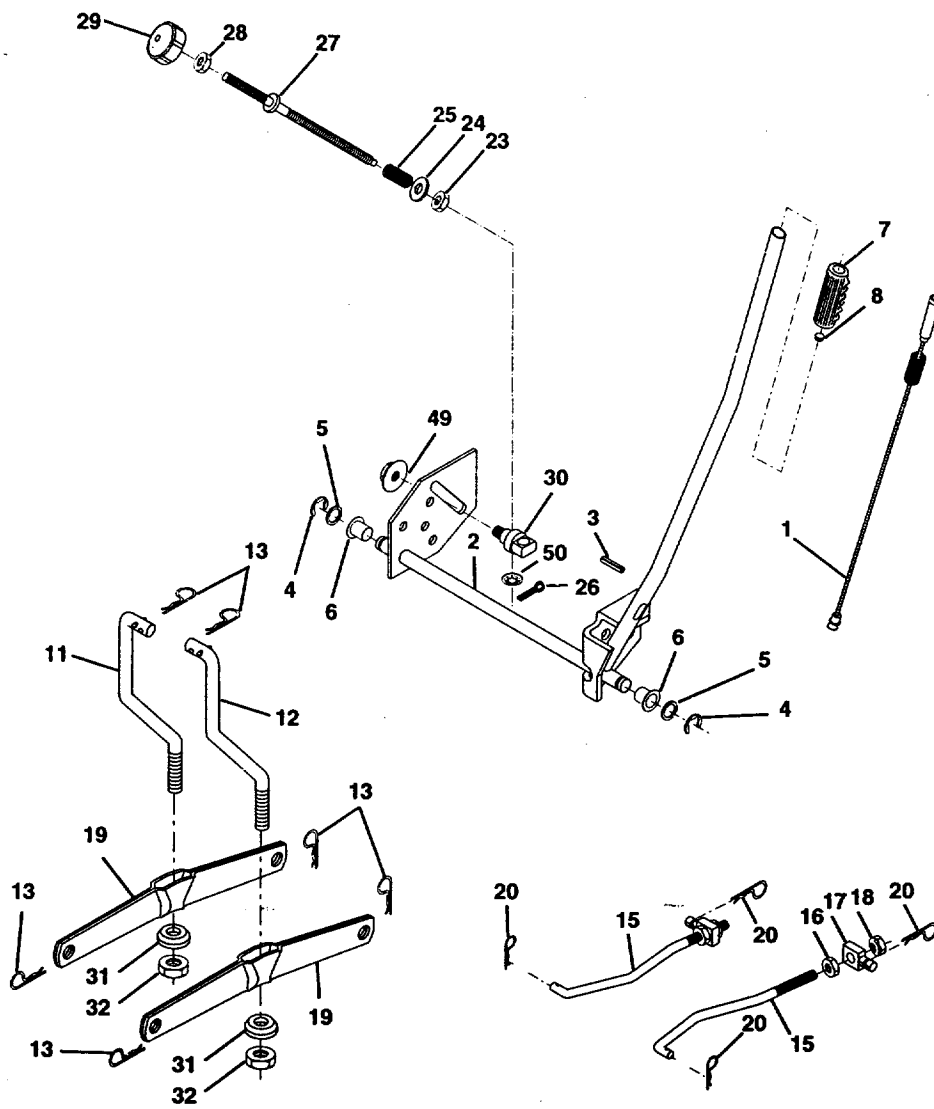

TRACTOR -- MODEL NUMBER 917.271110

LIFT ASSEMBLY

KEY NO.	PART NO.	DESCRIPTION
1	159460	Wire Asm Inner/Sprg w/Plunger LT
2	159471	Shaft Asm. Lift
3	105767X	Pin Groove
4	12000002	E Ring #5133-62
5	19211621	Washer 21/32 x 1 x 21 Ga.
6	120183X	Bearing Nylon
7	125631X	Grip Handle Fluted
8	122365X	Button Plunger Red
11	139865	Link Lift Lh Fixed Length
12	139866	Link Lift Rh Fixed Length
13	STD624008	Retainer Spring
15	127218	Link Front
16	73350800	Nut Jam Hex 1/2-13 Unc
17	130171	Trunnion Blk Zinc
18	73800800	LockNut, Hex, with Washer Insert 1/2-13 UNC
19	139868	Arm, Suspension Rear
20	STD624008	Retainer Spring
23	110807X	Nut Special
24	19131016	Washer 13/32 x 5/8 x 16 Ga.
25	2876H	Spring 2-1/8"
26	76020308	Pin Cotter 3/32 x 1/2
27	126971X	Rod Adjust Lift Zinc 7.49 Wrk
28	73350600	Nut Hex Jam 3/8-16unc
29	138057	Knob Inf 3/8-16unc Blk W/Syn
30	150233	Trunnion Infin Height
31	140302	Bearing, Pivot, Lift Spherical
32	73540600	Nut, Crownlock 3/8-24
49	145212	Nut Hex Flange Lock
50	110452X	Nut Push Phos & Oil

NOTE: All component dimensions given in U.S. inches
1 inch = 25.4 mm

TRACTOR -- MODEL NUMBER 917.271110

MOWER DECK

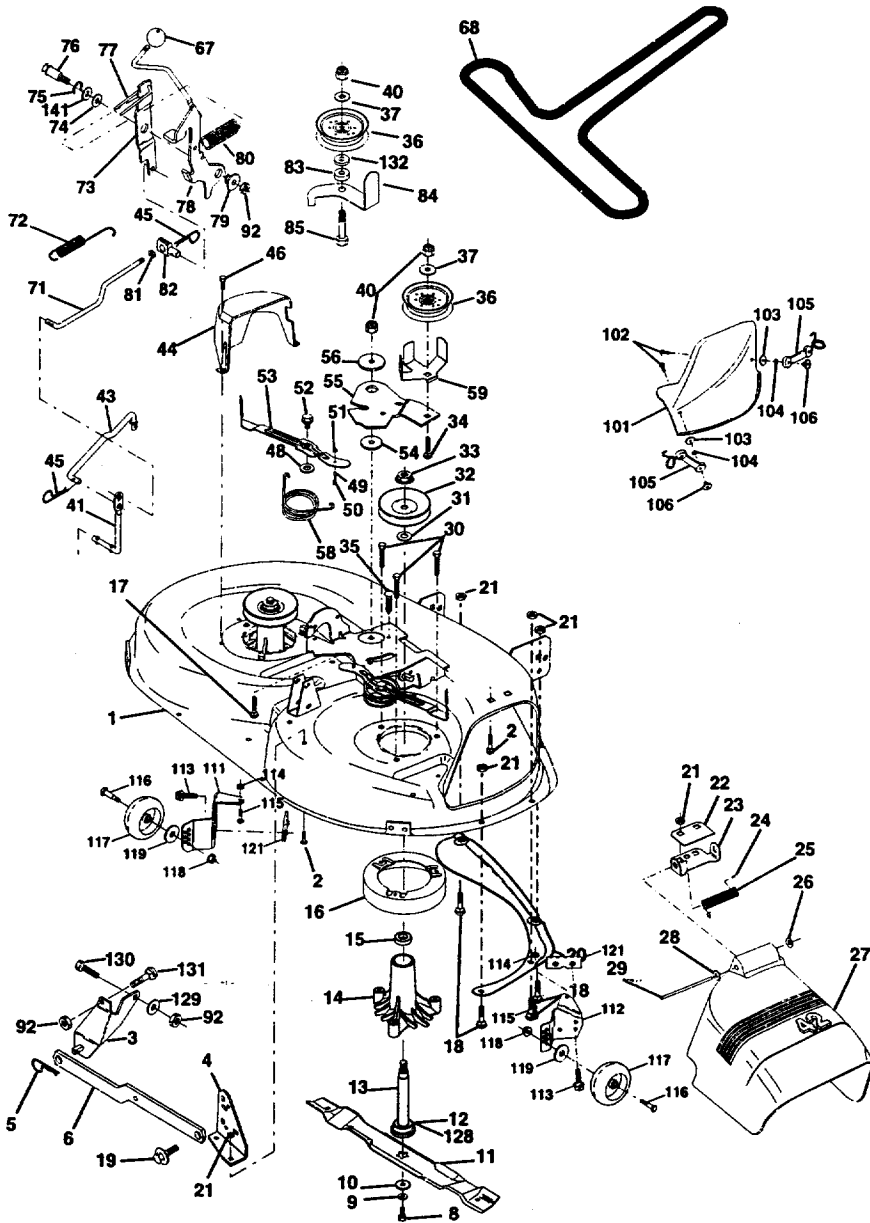

TRACTOR - - MODEL NUMBER 917.271110

MOWER DECK

KEY NO.	PART NO.	DESCRIPTION	KEY NO.	PART NO.	DESCRIPTION
1	144393	Mower Housing	55	155046	Arm, Idler
2	STD533107	Bolt	56	122052X	Spacer, Retainer
3	138017	Bracket Assembly, Sway Bar, Front	58	140086	Spring, Torsion Brakes
4	138440	Bracket Assembly, Sway Bar	59	141043	Guard, TUV Idler
5	STD624008	Retainer Spring	67	162113	Knob Custom Oval
6	130832	Arm, Suspension, Rear	68	144200	V-Belt
8	850857	Bolt, Hex 3/8-24 x 1.25 Grade 8	71	142427	Rod, Clutch, Primary, with Nibs
9	STD551137	Washer, Lock	72	131870	Spring, Return
10	140296	Washer, Hardened	73	127847	Arm, Clutch, Secondary
11	134149	Blade, Mulching	74	121748X	Washer 25/32 x 1-5/8 x 16 Gauge
12	129895	Bearing, Ball	75	12000029	Ring, Klip
13	137645	Shaft Assembly, Mandrel, Vented (Includes Key Number 6)	76	128903	Bolt, Shoulder 3/8-16 UNC x 1.44
14	128774	Housing, Mandrel, Vented	77	127845	Keeper, Spring
15	110485X	Bearing, Ball, Mandrel	78	160570	Lever Asm. Clutch Pri Plm STLT
16	140329	Stripper, Vented Mower Deck	79	127498	Bushing, Large, Brass
17	72110610	Bolt, Carriage 3/8-16 x 1-1/4	80	153701	Spring, Mower Clutch
18	STD533106	Bolt, Carriage 5/16-18 x 5/8	81	STD541237	Nut, Hex Jam 3/8-16 Unc
19	132827	Bolt, Shoulder	82	142028	Trunnion, Adj.
20	159770	Baffle, Vortex	83	120958X	Washer Sintered
21	STD541431	Nut Crownlock 5/16-18 UNC	84	156084	Keeper Bell Idler
22	134753	Stiffener Bracket	85	72140618	Bolt Carriage 3/8-16 x 2-1/4
23	131267	Bracket, Deflector	92	STD541437	Nut
24	105304X	Cap, Sleeve	101	136420	Mulcher Cover
25	123713X	Spring, Torsion, Deflector	102	71161010	Screw
26	110452X	Nut, Push	103	19061216	Washer #10
27	130968	Shield, Deflector	104	STD551110	Washer, Lock
28	19111016	Washer 11/32 x 5/8 x 16 Gauge	105	160793	Latch Assembly, Bagger
29	131491	Rod, Hinge	106	2029J	Nut, Weld
30	157722	Screw Thdrol Washer Head	111	155197	Bracket, Gauge, Wheel L.H.
31	129963	Washer, Spacer	112	155198	Bracket, Gauge, Wheel R.H.
32	153535	Pulley, Mandrel	113	17490512	Screw Thdrol 5/16-18 x 3/4
33	137266	Nut, Toplock, Flanged	114	STD541431	Nut, Hex, Keps 5/16-18 UNC
34	STD533717	Bolt	115	72110504	Bolt, Carriage 5/16 UNC x 1/2
35	133835	Fastener, Christmas Tree	116	137644	Bolt, Shoulder
36	131494	Pulley, Idler, Flat	117	133957	Wheel, Gauge
37	STD551037	Washer 13/32 x 13/16 x 16 Gauge	118	73930600	Nut, Centerlock 3/8-16
40	STD541437	Nut Crownlock 3/8-16 UNC	119	STD551037	Washer 3/8 x 7/8 x 14 Gauge
41	133551	Rod, Pivot, with Nibs	121	143723	Bracket
43	140083	Rod, Clutch, Secondary, with Nibs	128	153390	Washer Felt
44	140088	Guard, Mandrel, L.H.	129	19131312	Washer 13/32 x 13/16 x 12 Ga.
45	STD624003	Retainer	130	STD523710	Bolt, Fin Hex 3/8-16 UNC x 1 Gr. 5
46	137729	Screw, Thd. Roll 1/4-20 x 5/8	131	STD533710	Bolt, RDHD SQNK 3/8-16 UNC x 1
48	133944	Washer, Hardened	132	19132203	Spacer, Washer 13/32 I.D. x 1-3/8 O.D. x 1/4
49	155066	Roller Assembly, Cam Follower	141	6266H	Washer Thrust .75 x 1.230
50	131340	Bolt, Shoulder #10-24 Grade 5	--	130794	Mandrel Assembly (Includes Key Numbers 8-10, 12-15, 31 and 32)
51	STD541410	Locknut	--	145411	Mower Deck, Complete (Standard Deck, Order Separately Mulcher Plate and Gauge Wheel Components, Key Nos. 101-106 and 111-121)
52	139888	Bolt, Shoulder 5/16-18 UNC			
53	131845X900	Arm Assembly, Pad, Brake			
54	133943	Washer, Hardened			

NOTE: All component dimensions given in U.S.inches
1 inch = 25.4 mm

TRACTOR -- MODEL NUMBER 917.271110
DANA TRANSAXLE -- MODEL NUMBER D4360-122

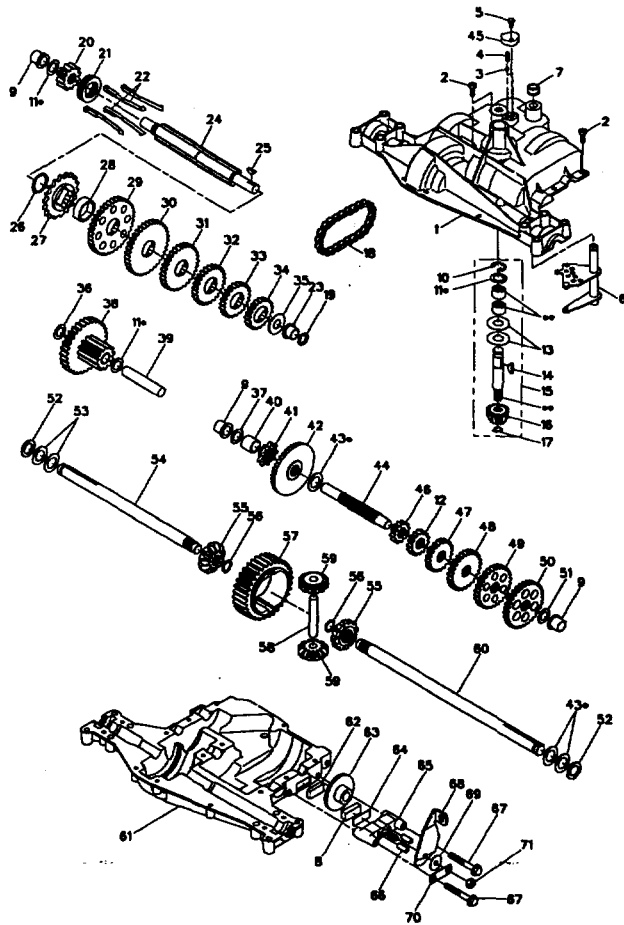

TRACTOR -- MODEL NUMBER 917.271110

DANA TRANSAXLE -- MODEL NUMBER D4360-122

KEYPART NO.NO.	DESCRIPTION	KEYPART NO.NO.	DESCRIPTION
1 160955	Housing, Upper	37 2231J	Washer, Plain, .632 X 1.00 X .031
2 2274J	Screw, Tapping, 1/4-20 X .734	38 160944	Assy, Gear, Comb., 12T & 30T
3 134400	Ball, Detent	39 124639X	Shaft, Idler
4 105904X	Spring, Detent	40 120472X	Spacer, .633 X .87 X .755
5 160940	Screw, Tapping, No. 10-24 X .482	41 105928X	Sprocket, 9T
6 134788	Assy, Kit, Shifter	42 161565	Gear, Bevel, 36T
7 108727X	V-Ring	43 134394	Assy, Kit, Shim, .750 Shaft
8 120951X	Puck, Friction	44 120473X	Shaft, Drive
9 148266	Bearing, Flange	45 160942	Cover, Detent
10 2225J	Ring, Retaining	46 142678	Gear, Spur, 12T
11 134793	Assy, Kit, Shim, .625 Shaft	47 124641X	Gear, Spur, 20T
12 143697	Gear, Spur, 15T	48 106589X	Gear, Spur, 25T
13 120415X	Washer, Plain, .632 X 1.38 X .046	49 120408X	Gear, Spur, 28T
14 142674	Key, Woodruff, No. 9	50 105937X	Gear, Spur, 31T
15 161563	Assy, Kit, Input Shaft	51 2226J	Washer, Plain, .632 X 1.00 X .060
16 161564	Pinion, Bevel, 12T	52 134401	Washer, Neoprene
17 105909X	Ring, Retaining	53 2264J	Washer, Plain, .758 X 1.25 X .031
18 105910X	Chain, 24 Pitches	54 160946	Axle, LH
19 148269	Seal, Oil	55 160947	Gear, Miter, 12T, Splined
20 160943	Gear, Spur, 12T	56 160948	Ring, Retaining
21 138246	Collar, Clutch	57 110071X	Gear, Spur, 32T
22 138238	Assy, Kit, Clutch Keys	58 120952X	Shaft, Cross
23 148268	Bearing, Flange	59 160949	Gear, Miter, 12T, Idler
24 143673	Shaft, Intermediate	60 160950	Axle, RH
25 2244J	Key, Woodruff, No. 61	61 160951	Housing, Lower
26 105916X	Ring, Retaining	62 120961X	Puck, Friction
27 120470X	Sprocket, 18T	63 7294J	Disc, Brake
28 110070X	Spacer, 1.131 X 1.45 X .494	64 108989X	Spacer, Brake Puck
29 142677	Gear, Spur, 37T	65 160952	Jaw, Brake
30 142681	Gear, Spur, 35T	66 120954X	Pin, Dowel
31 124644X	Gear, Spur, 30T	67 160953	Screw, Tapping, 5/16-18 X 2.35
32 108980X	Gear, Spur, 25T	68 138244	Lever, Actuating
33 120406X	Gear, Spur, 22T	69 108996X	Washer, Plain, .321 X 1.00 X .055
34 134796	Gear, Spur, 19T	70 160954	Bracket, Anti-Rotation
35 105925X	Washer, Plain, .640 X 1.37 X .061	71 73810500	Nut, Lock, 5/16-24
36 2228J	Washer, Plain, .632 X 1.00 X .046	72 120416X	Grease

**NOTE: All component dimensions given in U.S. inches
1 inch = 25.4 mm**

TRACTOR -- MODEL NUMBER 917.271110
KOHLER ENGINE - MODEL NUMBER CV16, TYPE NUMBER PS-43513

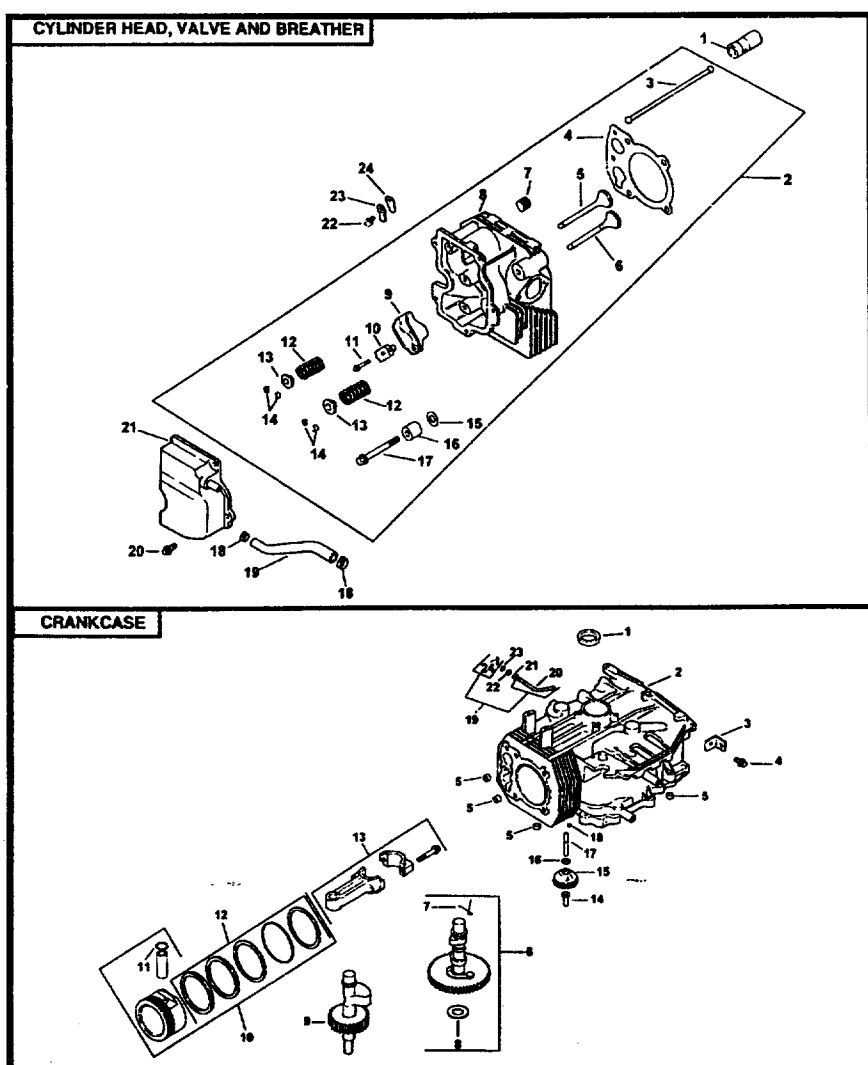

TRACTOR -- MODEL NUMBER 917.271110
KOHLER ENGINE - MODEL NUMBER CV16, TYPE NUMBER PS-43513

CYLINDER HEAD/VALVE/BREATHER

KEYPART NO.NO.	DESCRIPTION
1	12-351-02 Lifter, valve (2)
2	12-755-63 Kit, cylinder head (Includes 3-17)
3	12-411-01 Rod, push (2)
4	12-041-10 Gasket, cylinder head
5	12-017-01 Valve, intake (Std.)
	12-017-02 Valve, intake (.25)
6	12-016-01 Valve, exhaust (Std.)
	12-016-02 Valve, exhaust (.25)
7	X-75-23 Plug, allen hd. pipe 1/8
8	12-318-19 Cylinder Head
9	25-186-01 Arm, rocker (2)
10	12-599-03 Pivot, rocker arm (2)
11	M-0640034 Screw, hex. flange M6x1.0x34 (2)
12	12-089-01 Spring, valve (2)
13	12-173-01 Cap, valve spring (2)
14	12-755-03 Kit, retainer (2)
15	12-468-05 Washer, plain 13/32
16	12-112-13 Spacer, head bolt exhaust port
17	12-086-15 Screw, hex. flange M10x1.5x81 (5)
18	X-426-9 Clamp, hose (2)
19	12-326-03 Hose, breather
20	M-0645020 Screw, hex. flange M6x1.0x20 (5)
21	12-096-07 Cover, valve w/nipple
22	M-0545010 Screw, hex. flange M5x0.8x10
23	12-018-01 Retainer, breather reed
24	12-402-02 Reed, breather

CRANKCASE

KEYPART NO.NO.	DESCRIPTION
1	12-032-03 Seal, crankshaft
2	Block, cylinder (Use Short Block 12 522 18)
3	12-445-02 Strap, lifting
4	M-0839025 Screw, hex. flange M8x1.25x25
5	12-380-17 Dowel, locating (4)
6	12-755-49 Kit, camshaft (Includes 7-8)
7	12-089-18 Spring, actuating
8	12-422-08 Shim, camshaft - blue
	12-422-09 Shim, camshaft (A.R.) red
	12-422-10 Shim, camshaft (A.R.) yellow
	12-422-11 Shim, camshaft (A.R.) green
	12-422-12 Shim, camshaft (A.R.) gray
	12-422-13 Shim, camshaft (A.R.) black
	12-422-07 Shim, camshaft (A.R.) white
9	12-144-19 Shaft, balance
10	12-874-07 Piston w/Ring Set (Std.) (Includes 11-12)
	12-874-08 Piston w/Ring Set (.25)
	12-874-09 Piston w/Ring Set (.50)
11	12-018-02 Retainer, piston pin (2)
12	12-108-07 Ring Set (Std.)
	12-108-08 Ring Set (.25)
	12-108-09 Ring Set (.50)
13	12-067-05 Connecting Rod (Std.)
	12-067-06 Connecting Rod (.25)
14	12-380-01 Pin, governor regulating
15	12-043-05 Gear, governor assembly
16	M-0631005 Washer, plain 6mm
17	12-144-02 Shaft, governor gear
18	52-139-09 Plug, cup
19	12-755-64 Kit, gov. cross shaft w/clip (Includes 20,24)
20	12-144-24 Shaft, governor cross
21	X-25-102 washer, plain 1/4
22	12-032-01 Seal, governor cross shaft
23	SM-0631015 Washer, plain 6mm
24	12-154-05 Clip, hitch pin

TRACTOR -- MODEL NUMBER 917.271110
KOHLER ENGINE - MODEL NUMBER CV16, TYPE NUMBER PS-43513

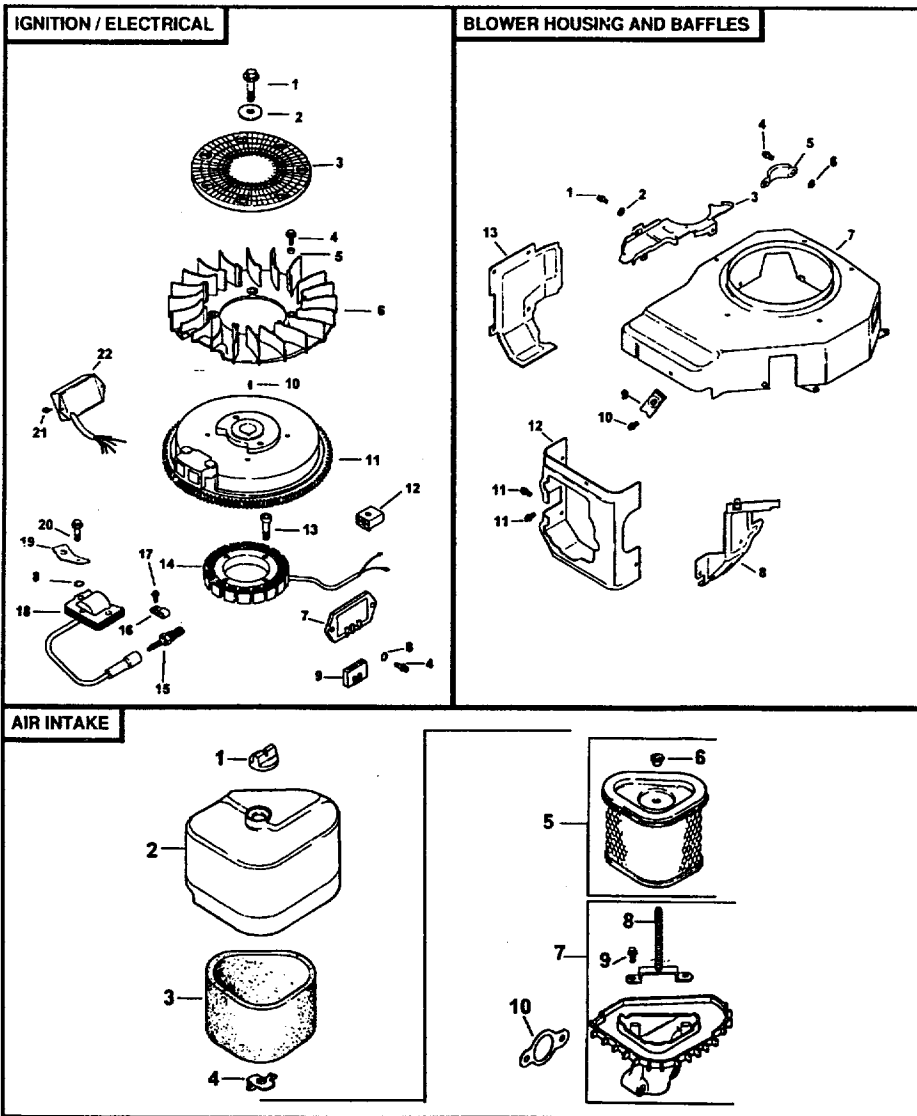

TRACTOR -- MODEL NUMBER 917.271110
KOHLER ENGINE - MODEL NUMBER CV16, TYPE NUMBER PS-43513

IGNITION/ELECTRICAL

KEYPART NO.NO.	DESCRIPTION
1	12-086-14 Screw, hex. flange M10x1.5x46
2	12-468-03 Washer, plain 3/8
3	24-162-03 Screen, grass
4	M-0639016 Screw, hex. flange M6x1.0x16 (6)
5	12-112-01 Spacer, fan (4)
6	12-157-03 Fan
7	41-403-09 Regulator, rectifier
8	X-22-11 Washer, lock (2)
9	236602 Connector
10	X-42-15 Key
11	12-025-35 Flywheel
12	41-155-02 Connector (4 contact)
13	M-0548025 Screw, hex. cap M5x0.8x25 (2)
14	12-085-01 Stator assembly - 15 amp
15	12-132-02 Spark Plug
16	X-728-1 Clip, cable (2)
17	M-0545010 Screw, hex. flange M5x0.8x10 (2)
18	12-584-07 Module, ignition
19	12-452-02 Terminal
20	12-086-35 Screw, hex. socket M5x0.8x20 (2)
21	M-0461013 Screw, pan head M4.2x13 (2)
22	12-584-06 Module, speed advance
NOT ILLUSTRATED	
25-518-29	Lead
25-518-05	Lead
12-176-31	Harness
X-25-5	Washer, plain 5/16"
12-155-02	Connector

BLOWER HOUSING & BAFFLES

KEYPART NO.NO.	DESCRIPTION
1	M-0545010 Screw, hex. flange M5x0.8x10 (8)
2	24-468-10 Washer, plain 1/4
3	12-146-07 Plate, blower housing
4	M-0645020 Screw, hex. flange M6x1.0x20
5	24-096-05 Cover, pinion
6	220534 Washer, plain 5/16 (2)
7	12-027-54 Housing, blower
8	12-063-05 Baffle, intake side
9	25-154-02 Clip, mounting (3)
10	SM-0545020 Screw, hex. flange M5x0.8x20 (3)
11	M-0645016 Screw, hex. flange M6x1.0x16 (2)
12	12-063-08 Baffle, cylinder head
13	12-063-01 Baffle, cylinder

AIR INTAKE/FILTRATION

KEYPART NO.NO.	DESCRIPTION
1	25-341-03 Knob, air cleaner cover
2	12-096-24 Cover, air cleaner
3	12-083-08 Precleaner, element
4	12-100-01 Wing Nut
5	12-083-05 Element, air cleaner (Includes 6)
6	12-032-10 Seal
7	12-094-12 Base, air cleaner (Includes 8-9)
8	12-072-03 Stud M6x1.0x75
9	12-086-01 Screw, hex. cap #10 Hi-Lo thread forming (2)
10	12-041-02 Gasket, air cleaner
NOT ILLUSTRATED	
12-113-53	Decal, air cleaner

TRACTOR -- MODEL NUMBER 917.271110
KOHLER ENGINE - MODEL NUMBER CV16, TYPE NUMBER PS-43513

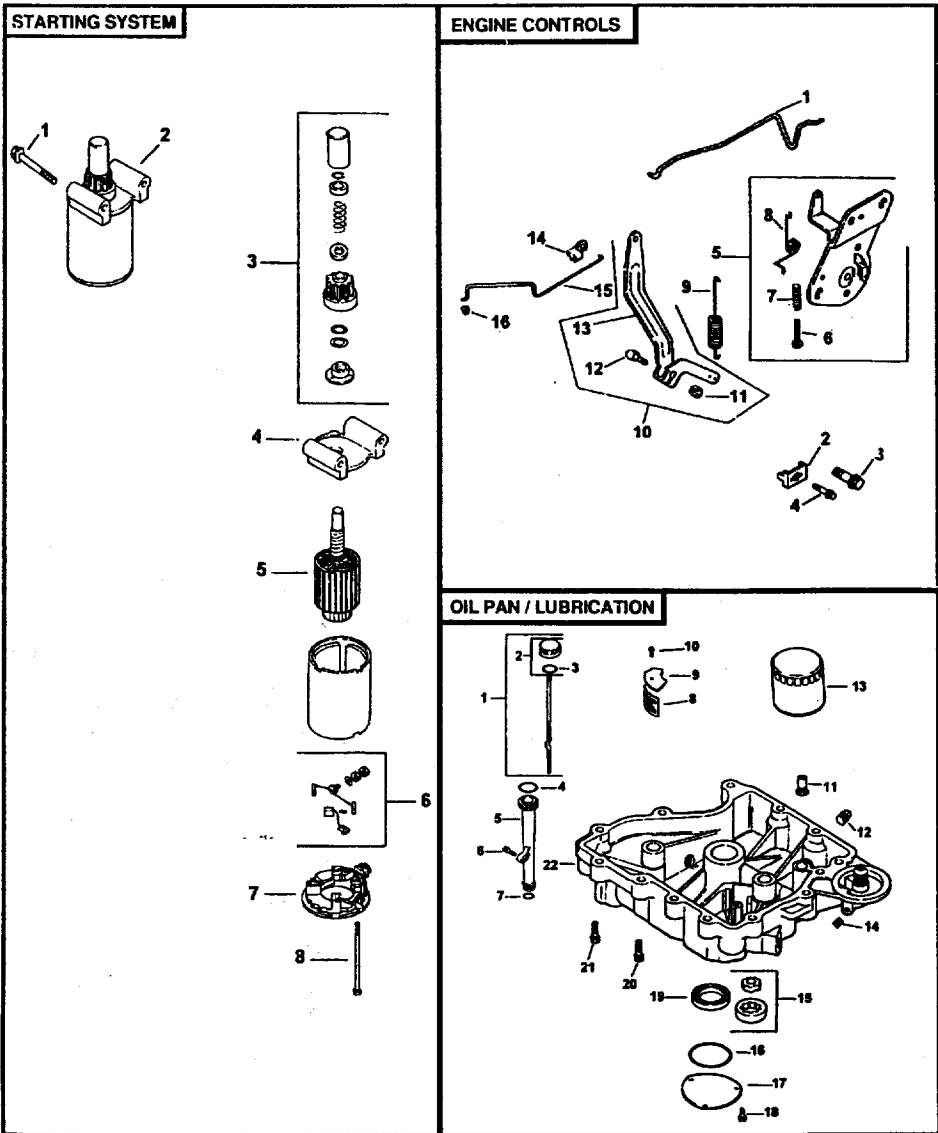

TRACTOR - - MODEL NUMBER 917.271110
KOHLER ENGINE - MODEL NUMBER CV16, TYPE NUMBER PS-43513

STARTING SYSTEM

KEYPART NO.NO.	DESCRIPTION
1 M-0839070	Screw, hex. flange M8x1.25x70 (2)
2 25-098-05	Starter assembly (Includes 3-8)
3 12-755-54	Kit, drive end
4 12-227-06	Cap, drive end
5 12-170-05	Armature
6 12-221-01	Kit, brush & spring
7 12-227-13	Cap, commutator end
8 12-211-01	Bolt, hex. flange 1/4-20x4-5/8 (2)

ENGINE CONTROLS

KEYPART NO.NO.	DESCRIPTION
1 12-079-07	Linkage, choke
2 12-237-01	Clamp, cable
3 M-0664020	Screw, lobed socket M6x1.0x20 (2)
4 M-0545016	Screw, hex. flange M5x0.8x16
5 12-536-10	Control, speed assembly (Includes 6,8,9?)
6 M-0443020	Screw, pan head M4x0.7x20
7 12-089-11	Spring, speed control (2)
8 12-089-23	Spring, choke return
9 12-089-24	Spring, governor
10 12-755-83	Kit, governor lever (Includes 11-13)
11 12-100-07	Nut, hex. flange M6x1.0
12 52-211-04	Bolt, round head
13 12-090-26	Lever, governor
14 25-158-11	Bushing, throttle linkage
15 12-079-01	Linkage, throttle
16 25-158-08	Bushing, linkage retaining

OIL PAN/LUBRICATION

KEYPART NO.NO.	DESCRIPTION
1 12-038-01	Dipstick assembly (Includes 2-3)
2 25-755-13	Kit, oil fill cap (Includes 3)
3 12-153-03	O-Ring, oil fill cap
4 12-153-02	O-Ring, upper oil fill tube
5 12-123-04	Tube, oil fill
6 SM-0545020	Screw, hex. flange M5x0.8x20
7 12-153-01	O-Ring, lower oil fill tube
8 25-162-07	Screen, oil pickup
9 12-096-03	Cover, oil pickup screen
10 M-0545016	Screw, hex. flange M5x0.8x16
11 25-462-09	Valve, oil pressure relief
12 X-75-2	Plug, pipe
13 12-050-01	Filter, oil
14 X-75-10	Plug, sq. hd. solid 3/8
15 12-393-01	Pump, oil assembly
16 12-153-06	O-Ring, oil pump cover
17 12-096-34	Cover, oil pump
18 M-0545016	Screw, hex. flange M5x0.8x16 (3)
19 12-032-03	Seal, oil (P.T.O. end)
20 24-086-16	Screw, hex. flange M8x1.25x45 (11)
21 24-086-17	Screw, hex. flange M8x1.25x45
22 12-199-38	Pan, oil

TRACTOR -- MODEL NUMBER 917.271110
KOHLER ENGINE - MODEL NUMBER CV16, TYPE NUMBER PS-43513

KEY PART NO.	PART NO.	DESCRIPTION	KEY PART NO.	PART NO.	DESCRIPTION
--------------	----------	-------------	--------------	----------	-------------

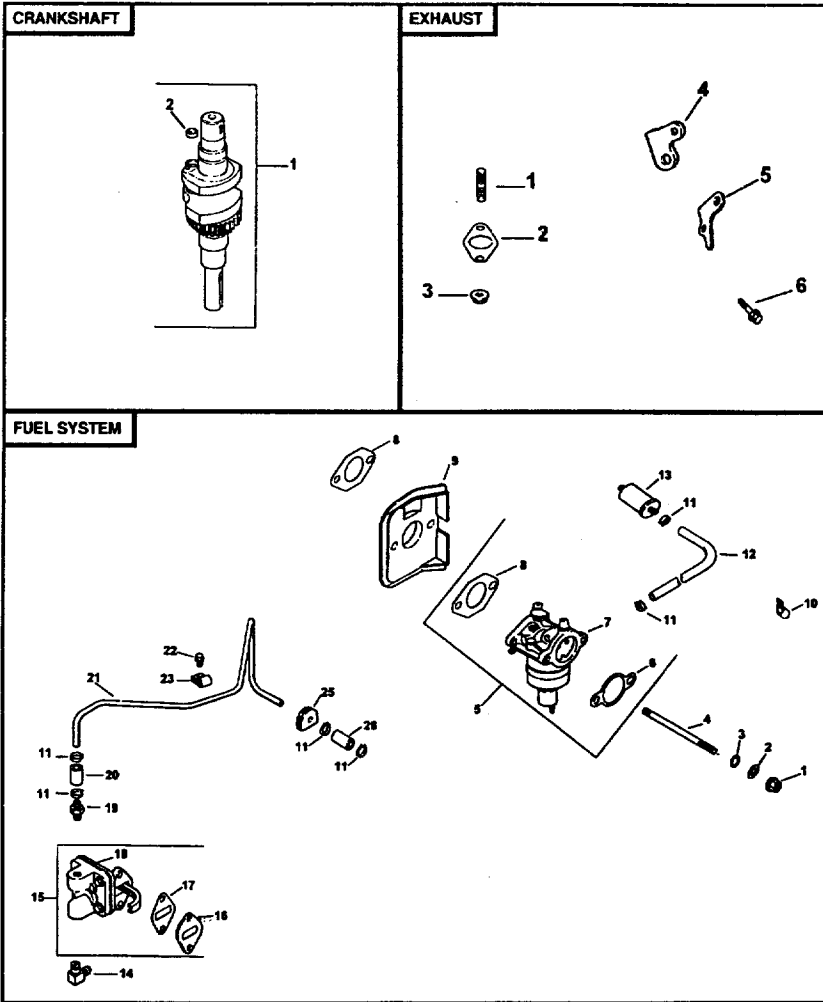

TRACTOR - - MODEL NUMBER 917.271110
KOHLER ENGINE - MODEL NUMBER CV16, TYPE NUMBER PS-43513

KEY PART NO. NO.	DESCRIPTION	KEY PART NO. NO.	DESCRIPTION
FUEL SYSTEM		CRANKSHAFT	
KEYPART NO.NO.	DESCRIPTION	KEYPART NO.NO.	DESCRIPTION
1 M-0641060	Nut, hex. flange M6x1.0 (2)	1 12-014-37	Crankshaft (Includes 2)
3 X-22-11	Washer, star 1/4	2 12-139-01	Plug, cup
4 M-0629116	Stud M6x1.0x116 (2)		
5 12-853-83	Kit, carburetor w/gasket (Includes 6,7,8 qty 1)	EXHAUST	
6 12-041-02	Gasket, air cleaner	KEYPART NO.NO.	DESCRIPTION
7 12-053-83	Carburetor assembly (For information only not available separately)	1 25-072-04	Stud (2)
8 12-041-01	Gasket, carburetor (2)	2 12-041-03	Gasket, exhaust manifold
9 12-265-04	Deflector, heat	4 12-126-11	Bracket, muffler
11 X-309-14	Clamp, hose (2)	5 12-445-06	Strap, lifting
12 52-353-22	Line, fuel 12"	6 M-0645025	Screw, hex. flange M6x1.0x25 (2)
13 25-050-02	Filter, fuel	12-522-18	Short Block
15 12-559-01	Kit, fuel pump w/gaskets (Includes 16-18)	12-755-82	Gasket Set
24 12-431-01	Sleeve, insulating		
NOT ILLUSTRATED			
12-757-02	Kit, float		
12-757-03	Kit, carburetor repair		
12-041-01	Gasket, carburetor		
12-041-02	Gasket, air cleaner		
12-041-05	Gasket, bowl		
12-041-06	Gasket, bowl screw		
12-032-06	Seal, solenoid		
12-757-09	Kit, solenoid		
12-041-06	Gasket, bowl screw		

SERVICE NOTES

SUGGESTED GUIDE FOR SIGHTING SLOPES FOR SAFE OPERATION

59

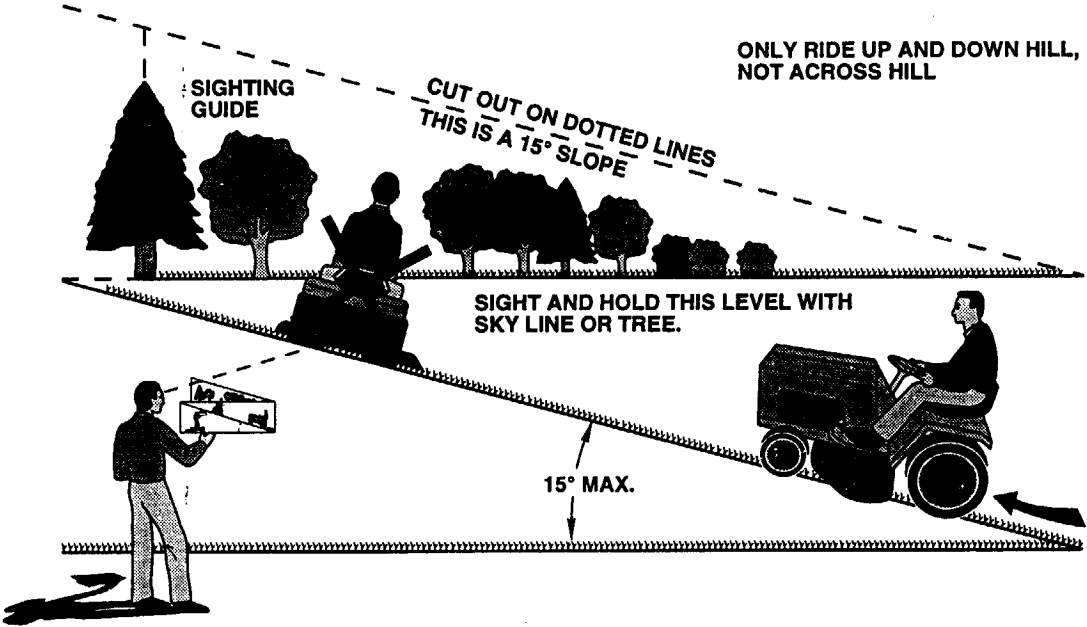

 Operate your Tractor up and down the face of slopes (not greater than 15°), never across the face. Make turns gradually to prevent tipping or loss of control. Exercise extreme caution when changing direction on slopes.

For the repair or replacement parts you need delivered directly to your home
Call 7 am - 7 pm, 7 days a week

1-800-366-PART

(1-800-366-7278)

Para ordenar piezas con entrega a domicilio - 1-800-659-7084

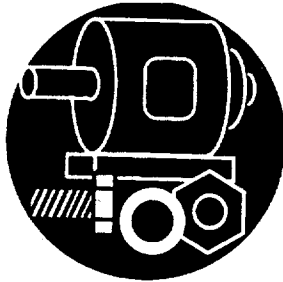

For in-house major brand repair service
Call 24 hours a day, 7 days a week

1-800-4-REPAIR

(1-800-473-7274)

Para pedir servicio de reparación a domicilio - 1-800-676-5811



For the location of a Sears Parts and Repair Center in your area
Call 24 hours a day, 7 days a week

1-800-488-1222



For information on purchasing a Sears Maintenance Agreement or to inquire about an existing Agreement
Call 9 am - 5 pm, Monday-Saturday

1-800-827-6655



When requesting service or ordering parts, always provide the following information:

- Product Type
- Part Number
- Model Number
- Part Description

SEARS
REPAIR SERVICES

America's Repair Specialists