

SEARS

Model No. 831.297940

Serial No. _____

Write the serial number in the space above for future reference.

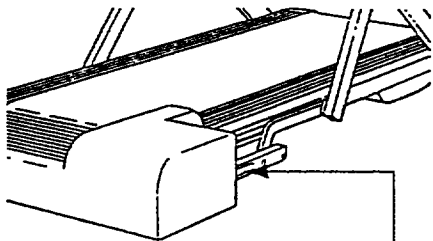

Serial Number Decal

EXERCISE
EQUIPMENT

QUESTIONS

HELPLINE!

1-800-736-6879

CAUTION

Read all precautions and instructions in this manual before using this equipment. Save this manual for future reference.

PRO-FORM

730

SIGHTLINE
PERFORMANCE TREADMILL

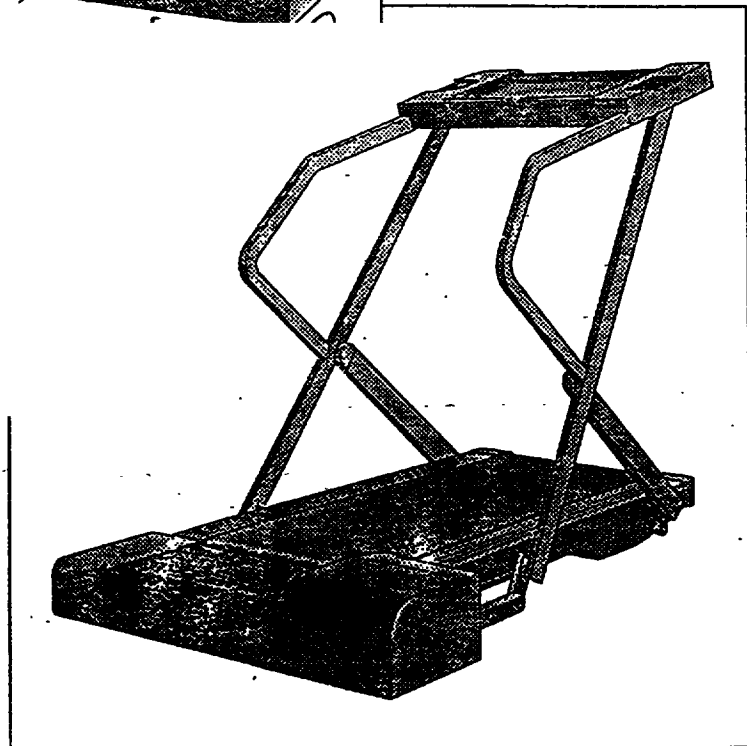
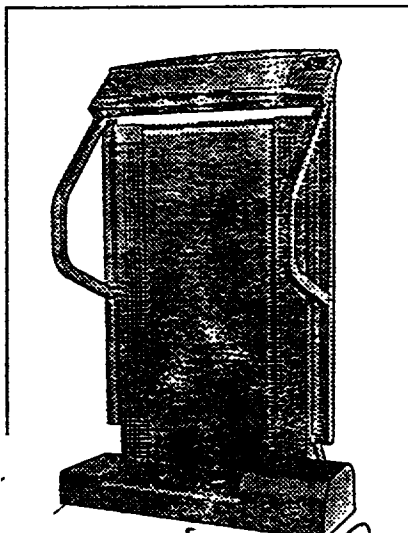

USER'S MANUAL

SEARS, ROEBUCK AND CO., HOFFMAN ESTATES, IL 60179

TABLE OF CONTENTS

| | |
|--|------------|
| FULL 90 DAY WARRANTY | 2 |
| IMPORTANT PRECAUTIONS | 3 |
| BEFORE YOU BEGIN | 5 |
| SET-UP | 6 |
| OPERATION AND ADJUSTMENT | 7 |
| HOW TO FOLD AND MOVE THE TREADMILL | 10 |
| MAINTENANCE AND TROUBLE-SHOOTING | 12 |
| CONDITIONING GUIDELINES | 14 |
| PART LIST | 15 |
| ORDERING REPLACEMENT PARTS | Back Cover |

Note: An EXPLODED DRAWING is attached in the center of this manual. Please save the EXPLODED DRAWING for future reference.

FULL 90 DAY WARRANTY

For 90 days from the date of purchase, if failure occurs due to defect in material or workmanship in this SEARS TREADMILL EXERCISER, contact the nearest SEARS Service Center throughout the United States and SEARS will repair or replace the TREADMILL EXERCISER, free of charge.

This warranty does not apply when the TREADMILL EXERCISER is used commercially or for rental purposes.

This warranty gives you specific legal rights, and you may also have other rights which vary from state to state.

SEARS, ROEBUCK AND CO., DEPT. 817WA, HOFFMAN ESTATES, IL 60179

IMPORTANT PRECAUTIONS

⚠ WARNING: To reduce the risk of burns, fire, electric shock, or injury to persons, read the following important precautions and information before operating the treadmill.

1. It is the responsibility of the owner to ensure that all users of this treadmill are adequately informed of all warnings and precautions.
2. Use the treadmill only as described in this manual.
3. Place the treadmill on a level surface. Do not place the treadmill on any surface that blocks air openings. To protect the floor or carpet from damage, place a mat under the treadmill.
4. Keep the treadmill indoors, away from moisture and dust. Do not put the treadmill in a garage or covered patio, or near water.
5. Do not operate the treadmill where aerosol products are used or where oxygen is being administered.
6. Keep children under the age of 12 and pets away from the treadmill at all times.
7. The treadmill should not be used by persons weighing more than 250 pounds.
8. Never allow more than one person on the treadmill at a time.
9. Wear appropriate exercise clothing when using the treadmill. Do not wear loose clothing that could become caught in the treadmill. Athletic support clothes are recommended for both men and women. *Always wear athletic shoes. Never use the treadmill with bare feet, wearing only stockings, or in sandals.*
10. When connecting the power cord (see page 7), plug the power cord into a surge suppressor (not included) and plug the surge suppressor into a grounded circuit capable of carrying 15 or more amps. No other appliance should be on the same circuit. Do not use an extension cord.
11. Use only a single-outlet surge suppressor that is UL 1449 listed as a transient voltage surge suppressor (TVSS). The surge suppressor must have a UL suppressed voltage rating of 400 volts or less and a minimum surge dissipation of 450 joules. The surge suppressor must be electrically rated for 120 volts AC and 15 amps.
12. Keep the power cord and the surge suppressor away from heated surfaces.
13. Never move the walking belt while the power is turned off. Do not operate the treadmill if the power cord or plug is damaged, or if the treadmill is not working properly. (See BEFORE YOU BEGIN on page 5 if the treadmill is not working properly.)
14. Never start the treadmill while you are standing on the walking belt. Always hold the handrails while using the treadmill.
15. The treadmill is capable of high speeds. Adjust the speed in small increments to avoid sudden jumps in speed.
16. To reduce the possibility of the treadmill overheating, do not operate the treadmill continuously for longer than 1 hour.
17. The pulse sensor is not a medical device. Various factors, including the user's movement, may affect the accuracy of heart rate readings. The pulse sensor is intended only as an exercise aid in determining heart rate trends in general.
18. Never leave the treadmill unattended while it is running. Always remove the key when the treadmill is not in use.
19. Do not attempt to raise, lower, or move the treadmill until it is properly assembled. (See SET-UP on page 6, and HOW TO MOVE THE TREADMILL on page 10.) You must be able to safely lift 65 pounds (30 kg) in order to raise, lower, or move the treadmill.
20. When folding or moving the treadmill, make sure that the storage latch is fully closed.

21. Inspect and tighten all parts of the treadmill every three months.
22. Never insert any object into any opening.
23. Always unplug the power cord before performing the maintenance and adjustment procedures described in this manual. Never remove the motor hood unless instructed to

do so by an authorized service representative. Servicing other than the procedures in this manual should be performed by an authorized service representative only.

24. This treadmill is intended for in-home use only. Do not use this treadmill in any commercial, rental, or institutional setting.

⚠ WARNING: Before beginning this or any exercise program, consult your physician. This is especially important for persons over the age of 35 or persons with pre-existing health problems. Read all instructions before using. SEARS assumes no responsibility for personal injury or property damage sustained by or through the use of this product.

SAVE THESE INSTRUCTIONS

The decal shown below has been placed on your treadmill. If the decal is missing, or if it is not legible, please call our toll-free HELPLINE to order a free replacement decal (see the back cover of this manual). Apply the decal in the location shown.

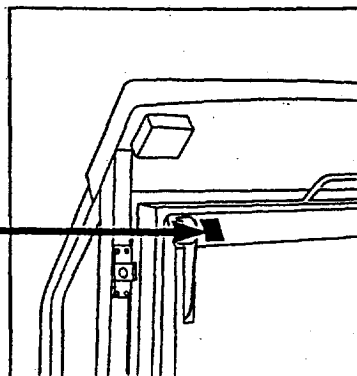
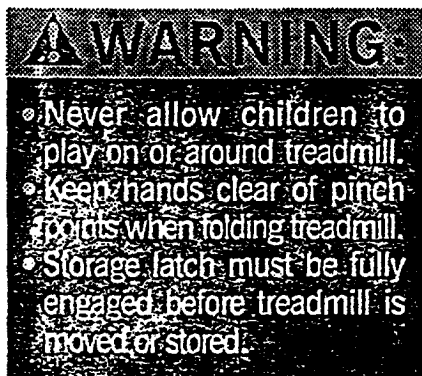

BEFORE YOU BEGIN

Thank you for selecting the revolutionary PROFORM® 730 SIGHTLINE treadmill. The 730 SIGHTLINE blends advanced technology with innovative design to let you enjoy an excellent form of cardiovascular exercise in the convenience and privacy of your home.

For your benefit, read this manual carefully before using the treadmill. If you have questions after reading the manual, please call our toll-free HELPLINE at 1-800-736-6879, Monday through Saturday, 7 a.m.

until 7 p.m. Central Time (excluding holidays). To help us assist you, please note the product model number and serial number before calling. The model number of the treadmill is 831.297940. The serial number can be found on a decal attached to the treadmill (see the front cover of this manual for the location).

Before reading further, please review the drawing below and familiarize yourself with the parts that are labeled.

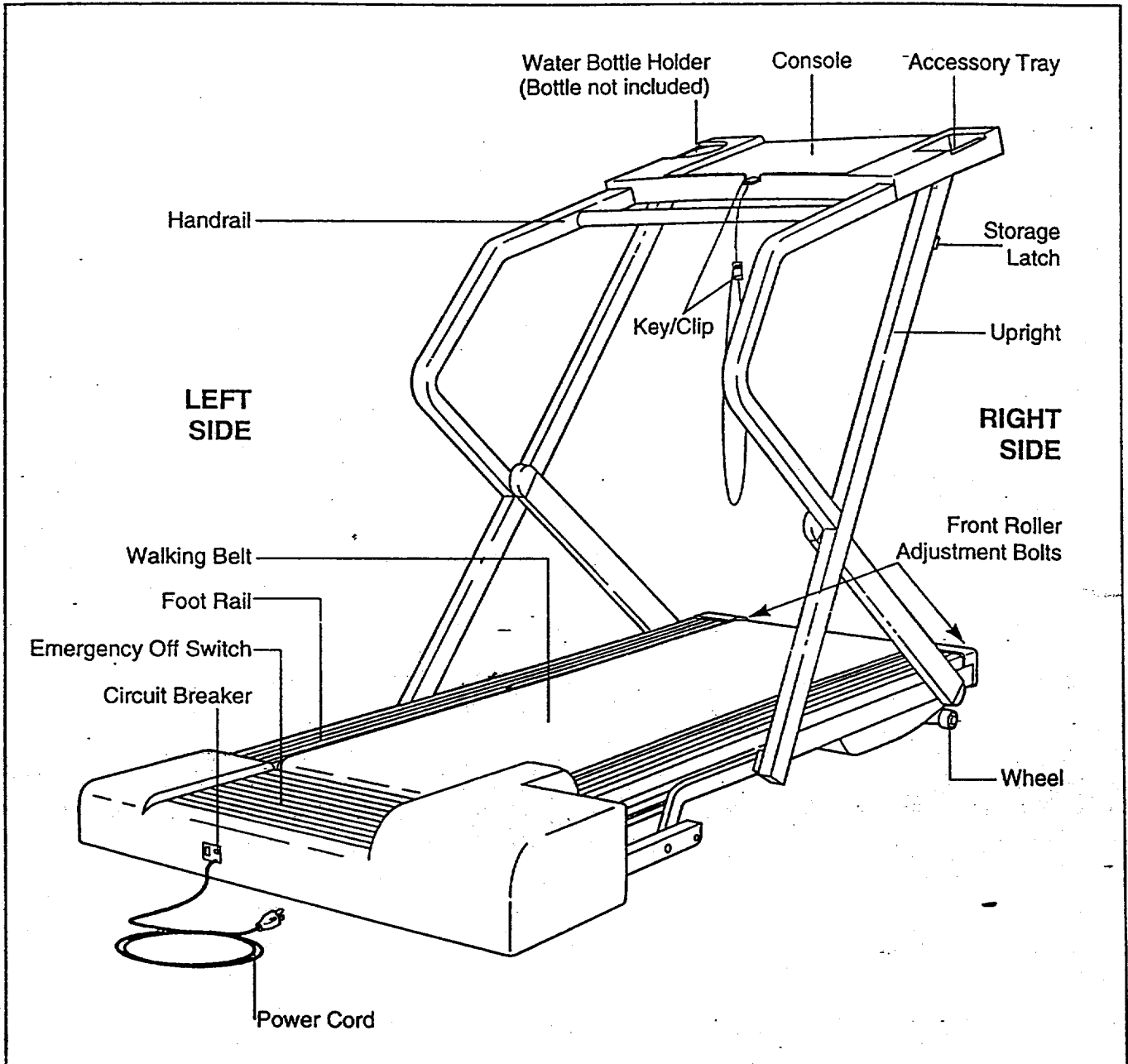

SET-UP

Setting up the treadmill requires two people. Set the treadmill in a cleared area and remove the packing materials. Do not dispose of the packing materials until set-up is completed. No tools are required.

1. With the help of a second person, carefully raise the treadmill to the position shown at the right.

Refer to HOW TO LOWER THE TREADMILL FOR USE on page 11. Follow the instructions on page 11 to lower the treadmill.

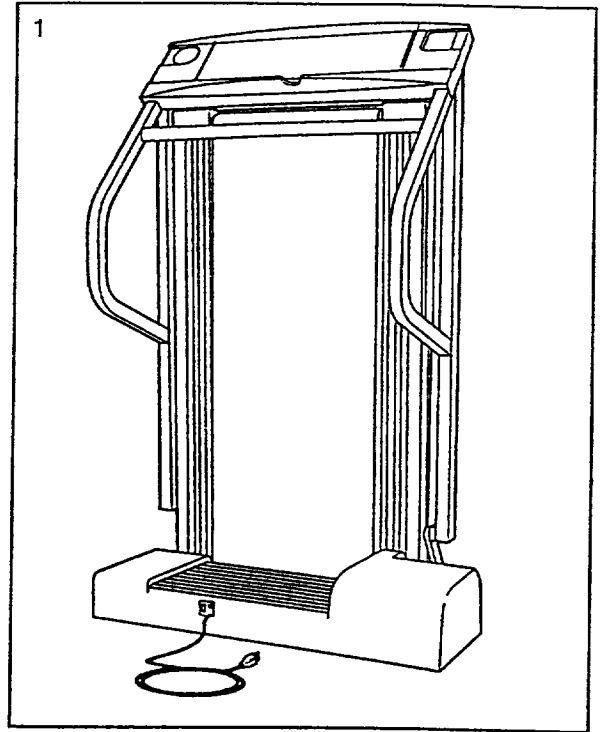

2. Remove the backing from the Adhesive Clip (68). Press the Adhesive Clip onto the Front Endcap (29) in the indicated location. Press the Allen Wrench (69) into the Adhesive Clip.

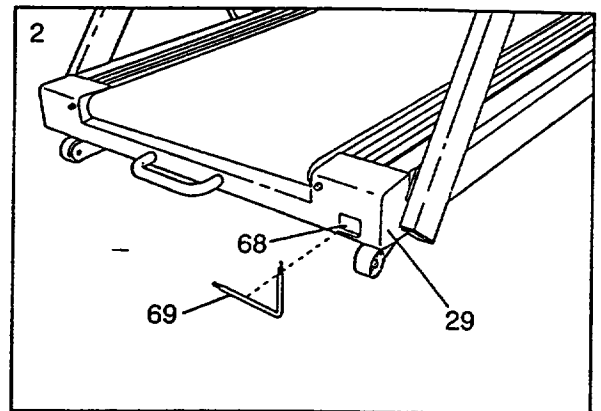

3. To protect the floor or carpet, place a mat under the treadmill. To order a mat, refer to the back cover of this manual.

OPERATION AND ADJUSTMENT

THE PERFORMANT LUBE™ WALKING BELT

Your treadmill features a walking belt coated with PERFORMANT LUBE™, a high-performance lubricant. **IMPORTANT:** Never apply silicone spray or other substances to the walking belt or the walking platform. Such substances will deteriorate the walking belt and cause excessive wear.

HOW TO PLUG IN THE POWER CORD

⚠ DANGER: Improper connection of the equipment-grounding conductor can result in an increased risk of electric shock. Check with a qualified electrician or serviceman if you are in doubt as to whether the product is properly grounded. Do not modify the plug provided with the product—if it will not fit the outlet, have a proper outlet installed by a qualified electrician.

Your treadmill, like any other type of sophisticated electronic equipment, can be seriously damaged by sudden voltage changes in your home's power. Voltage surges, spikes, and noise interference can result from weather conditions or from other appliances being turned on or off. To decrease the possibility of your treadmill being damaged, always use a surge suppressor with your treadmill (see drawing 1 at the right).

Surge suppressors are sold at most hardware stores and department stores. Use only a single-outlet surge suppressor that is UL 1449 listed as a transient voltage surge suppressor (TVSS). The surge suppressor must have a UL suppressed voltage rating of 400 volts or less and a minimum surge dissipation of 450 joules. The surge suppressor must be electrically rated for 120 volts AC and 15 amps.

This product must be grounded. If it should malfunction or break down, grounding provides a path of least resistance for electric current to reduce the risk of electric shock. This product is equipped with a cord having an equipment-grounding conductor and a grounding plug. Plug the power cord into a surge suppressor, and plug the surge suppressor into an appropriate outlet that is properly installed and grounded in accordance with all local codes and ordinances.

This product is for use on a nominal 120-volt circuit, and has a grounding plug that looks like the plug illustrated in drawing 1 below. A temporary adapter that looks like the adapter illustrated in drawing 2 may be used to connect the surge suppressor to a 2-pole receptacle as shown in drawing 2 if a properly grounded outlet is not available.

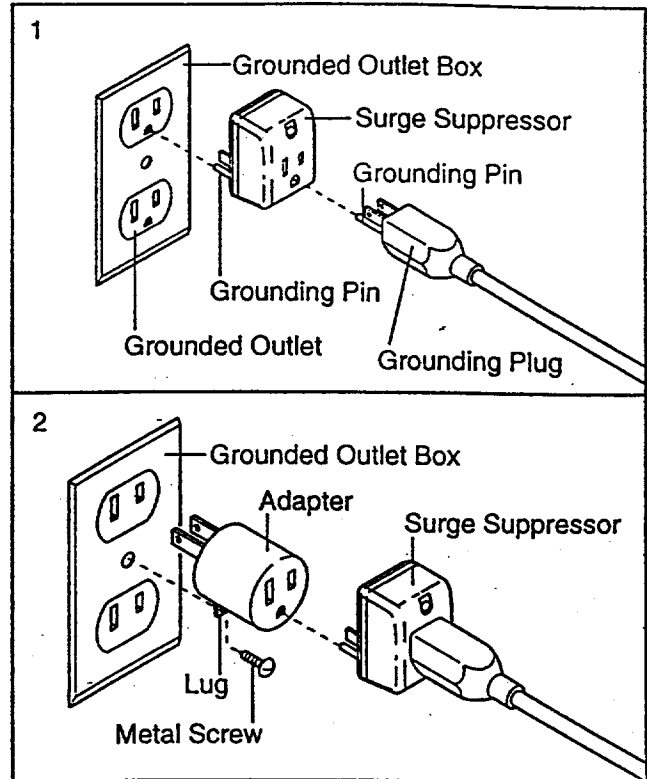

The temporary adapter should be used only until a properly grounded outlet (drawing 1) can be installed by a qualified electrician.

The green-colored rigid ear, lug, or the like extending from the adapter must be connected to a permanent ground such as a properly grounded outlet box cover. Whenever the adapter is used it must be held in place by a metal screw. Some 2-pole receptacle outlet box covers are not grounded. Contact a qualified electrician to determine if the outlet box cover is grounded before using an adapter.

DIAGRAM OF THE CONSOLE

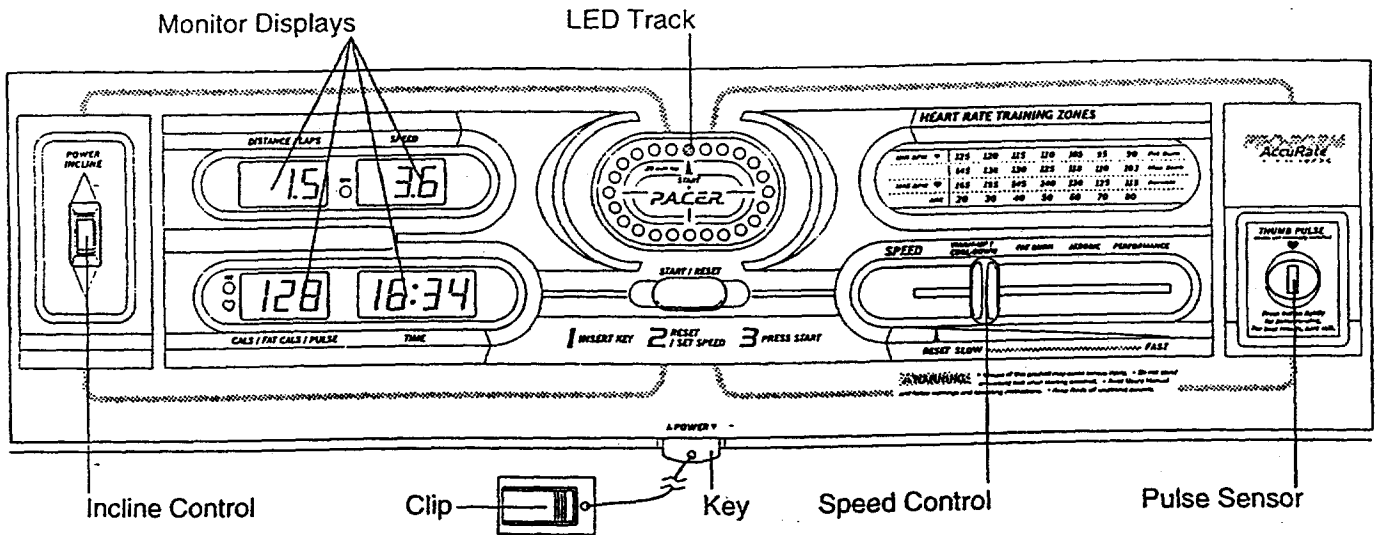

CAUTION: Before operating the console, read the following precautions.

- Do not stand on the walking belt when turning on the power.
- Always wear the clip while using the treadmill. When the key is removed from the console, the walking belt will stop.
- An emergency shut-off switch is built into the motor hood behind the walking belt. Any time that you step on the motor hood, the walking belt will stop.
- Adjust the speed in small increments.
- The settings marked above the speed control (warm-up/cool-down, fat burn, aerobic, and performance) are general guidelines only. See page 14 for more information.
- To reduce the possibility of electric shock, keep the console dry. Avoid spilling liquids on the console and use only a sealable water bottle.

STEP BY STEP CONSOLE OPERATION

If there is a thin sheet of clear plastic on the face of the console, remove it. Next, make sure that the power cord is properly plugged in (see HOW TO PLUG IN THE POWER CORD on page 7).

Stand on the foot rails of the treadmill. Find the clip attached to the key (see the drawing above), and slide the clip onto the waistband of your clothing.

Follow the steps below to operate the console.

1 Insert the key fully into the power switch.

After a moment, the four displays and one indicator in the LED track will light.

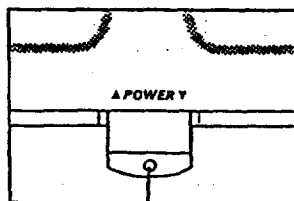

2 Reset the speed control.

Slide the speed control to the **RESET** position. Note: Each time the walking belt is stopped, the speed control must be moved to the **RESET** position before the walking belt can be restarted.

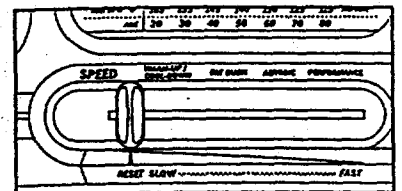

3 Start the walking belt.

Slowly slide the speed control to the right until the walking belt begins to move at slow speed. Step onto the walking belt. Change the speed of the walking belt as desired by sliding the speed control.

To stop the walking belt, step onto the foot rails and slide the speed control to the **RESET** position. After a few seconds, the displays will pause.

- 4** Follow your progress with the LED track and the four displays.

The LED Track—The LED track represents a distance of 1/4 mile. As you exercise, the indicators around the track will light one at a time until you have completed 1/4 mile. A new lap will then begin.

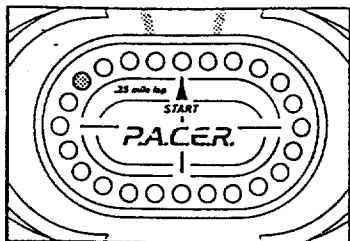

DISTANCE/LAPS display—This display shows the distance that you have walked and the number of laps you have completed. The display will change from one number to the other every seven seconds. An "L" will appear in the display when the number of laps is shown. Note: If the KPH indicator beside the SPEED display is lit, the distance will be shown in kilometers; if the indicator is not lit, the distance will be shown in miles.

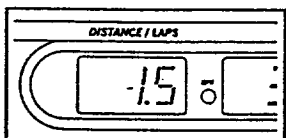

SPEED display—This display shows the speed of the walking belt. If the KPH indicator beside the display is lit, the speed will be shown in kilometers; if the indicator is dark, the speed will be shown in miles. To change the unit of measurement, press the START/RESET button for seven seconds.

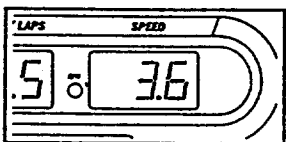

CALS/FAT CALS/PULSE display—This display shows the approximate numbers of calories and fat calories you have burned. (See BURNING FAT on page 14 for an explanation of fat calories.) Every seven seconds, the display will change from one number to the other. The FAT indicator will light when the number of fat calories is shown. Note: This display also shows your pulse when the pulse sensor is used.

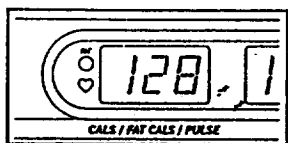

TIME display—This display shows the total time that you have walked since the display was reset.

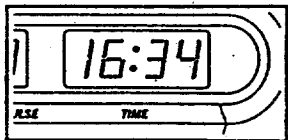

Note: If the walking belt is stopped and no console buttons are pressed for five minutes, the displays will automatically turn off. To light the displays, press the START/RESET button.

To reset the displays, press the START/RESET button. The displays will darken for a moment and then light.

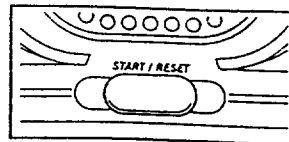

- 5** Measure your pulse, if desired.

Stand on the foot rails and place your thumb on the pulse sensor as shown. The pulse sensor is pressure-activated—fully press it down. (Do not press too hard, or the circulation in your thumb will be restricted, and your pulse will not be detected.) Next, raise your thumb slightly until the heart-shaped indicator by the CALS/FAT CALS/PULSE display flashes steadily.

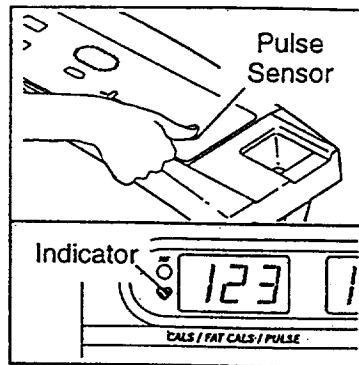

Hold your thumb at this level. After a few seconds, three dashes will appear in the display and your pulse will be shown. Hold your thumb on the sensor for another 15 seconds for the most accurate reading. If the displayed pulse appears to be too high or too low, or if your pulse is not displayed, lift your thumb off the sensor and allow the display to reset. Press down again on the sensor as described above.

Make sure that your thumb is positioned as shown, and that you are applying the proper amount of pressure to the pulse sensor. Try the sensor several times until you become familiar with it. Remember to stand still while measuring your pulse.

- 6** Change the incline of the treadmill, if desired.

To change the incline, hold down the top or bottom of the incline control until the desired incline level is reached. **Important:** Before folding the treadmill, adjust the incline to the lowest position.

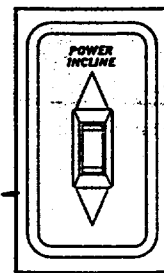

- 7** When you are finished exercising, stop the walking belt and remove the key.

Step onto the foot rails, stop the walking belt, and remove the key from the console. Store the key in a secure place.

HOW TO FOLD AND MOVE THE TREADMILL

HOW TO FOLD THE TREADMILL FOR STORAGE

Before folding the treadmill, unplug the power cord. **Caution:** You must be able to safely lift 65 pounds (20 kg) in order to raise, lower, or move the treadmill.

1. Grasp the storage handle with your right hand as shown. **Caution:** To avoid pinching your hands, do not hold the treadmill in any location other than the storage handle. To decrease the possibility of injury, bend your legs and keep your back straight. As you raise the treadmill, make sure to lift with your legs rather than your back. Raise the treadmill about halfway to the vertical position.

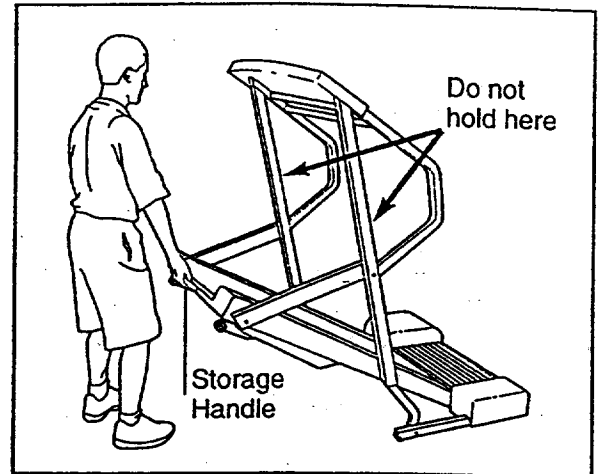

2. Continue to raise the treadmill. Pull the left upright with your left hand until the storage latch closes over the upright support. Make sure that the storage latch closes fully over the upright support.

To protect the floor or carpet from damage, place a mat under the treadmill. Keep the treadmill out of direct sunlight. Do not leave the treadmill in the storage position in temperatures above 85° Fahrenheit.

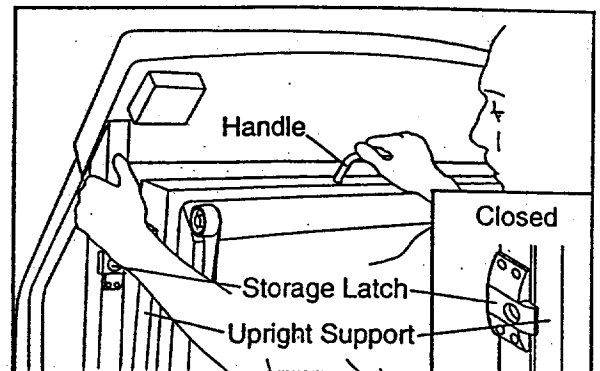

HOW TO MOVE THE TREADMILL

Before moving the treadmill, convert the treadmill to the storage position as described above. Make sure that the storage latch is closed fully over the upright support.

1. Hold the upper ends of the treadmill. Place one foot on the base as shown.
2. Tilt the treadmill back until it rolls freely on the wheels. Carefully move the treadmill to the desired location. **Never** move the treadmill without tipping it back. To reduce the risk of injury, use extreme caution while moving the treadmill. Do not attempt to move the treadmill over an uneven surface.
3. Place one foot on the base, and carefully lower the treadmill until it is resting in the storage position.

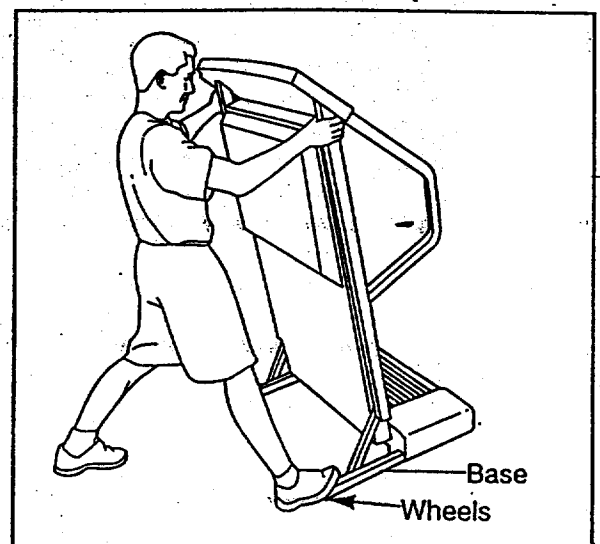

HOW TO LOWER THE TREADMILL FOR USE

1. Hold the storage handle with your right hand as shown. Using your left thumb, slide open the storage latch and hold it open. Pivot the treadmill until the upright support is past the storage latch.

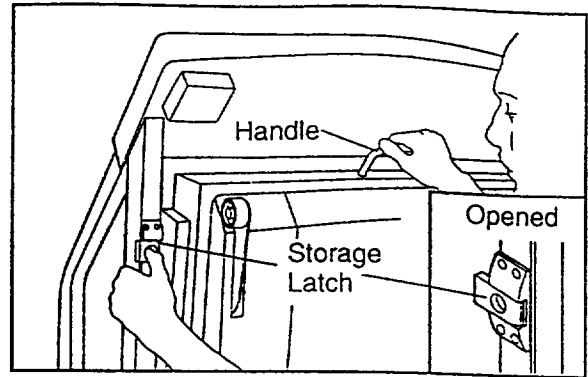

2. Hold the storage handle firmly with your right hand, and lower the treadmill to the floor. Caution: To avoid pinching your hands, do not hold the treadmill in any location other than the storage handle. To decrease the possibility of injury, bend your legs and keep your back straight. As you lower the treadmill, the console will move to a position above your head; be careful to avoid hitting the console.

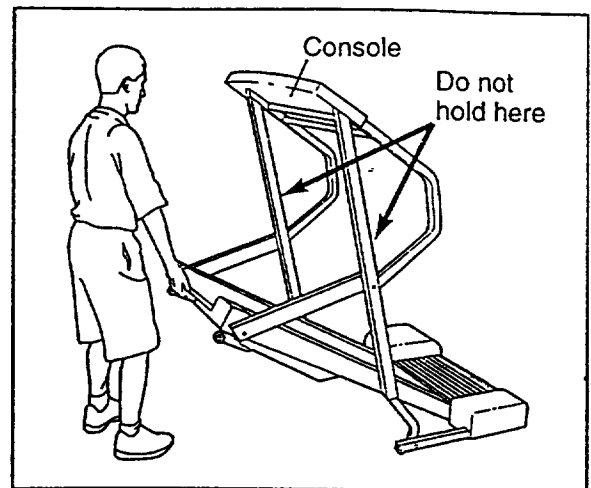

MAINTENANCE AND TROUBLE-SHOOTING

Most treadmill problems can be solved by following the simple steps below. If further assistance is needed, call our toll-free HELPLINE at 1-800-736-6879, Monday through Saturday, 7 a.m. until 7 p.m. Central Time (excluding holidays).

PROBLEM: The power does not turn on

SOLUTION: a. Make sure that the power cord is plugged into a surge suppressor, and that the surge suppressor is plugged into a properly grounded outlet (see page 7). Use only a single-outlet surge suppressor that is UL 1449 listed as a transient voltage surge suppressor (TVSS). The surge suppressor must have a UL suppressed voltage rating of 400 volts or less and a minimum surge dissipation of 450 joules. The surge suppressor must be electrically rated for 120 volts AC and 15 amps.

b. After the power cord has been plugged in, make sure that the key is fully inserted into the console.

c. Check the circuit breaker located on the treadmill near the power cord. If the switch protrudes as shown, the circuit breaker has tripped. To reset the circuit breaker, wait for five minutes and then press the switch back in.

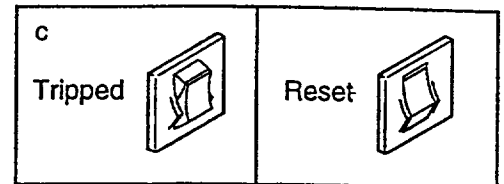

PROBLEM: The power turns off during use

SOLUTION: a. Check the circuit breaker located on the treadmill frame near the power cord (see 1. c. above). If the circuit breaker has tripped, wait for five minutes and then press the switch back in.

b. Make sure that the power cord is plugged in.

c. Remove the key from the console. Reinsert the key fully into the console.

d. Make sure that there is nothing pressing on the emergency shut-off switch built into the motor hood.

e. If the treadmill still will not run, please call our toll-free HELPLINE.

PROBLEM: The walking belt is off-center or slips when walked on

SOLUTION: a. If the walking belt has shifted to the left, first remove the key and **UNPLUG THE POWER CORD**. Using the allen wrench, turn the left front roller adjustment bolt clockwise, and the right bolt counterclockwise, 1/4 of a turn each. Be careful not to overtighten the walking belt. Plug in the power cord, insert the key and run the treadmill for a few minutes. Repeat until the walking belt is centered.

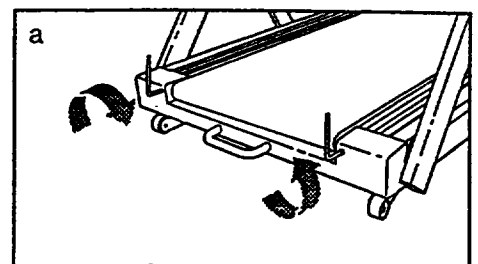

b. If the walking belt has shifted to the right, first remove the key and **UNPLUG THE POWER CORD**. Using the allen wrench, turn the left front roller adjustment bolt counterclockwise, and the right bolt clockwise, 1/4 of a turn each. Be careful not to overtighten the walking belt. Plug in the power cord, insert the key and run the treadmill for a few minutes. Repeat until the walking belt is centered.

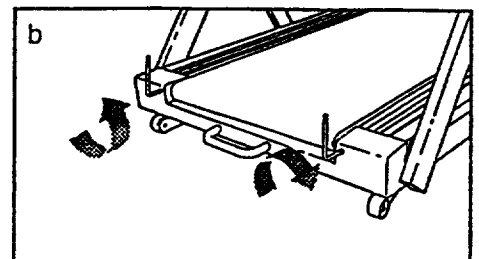

- c. If the walking belt slips when walked on, first remove the key and **UNPLUG THE POWER CORD**. Using the allen wrench, turn both front roller adjustment bolts clockwise 1/4 of a turn. When the walking belt is correctly tightened, you should be able to lift each side of the walking belt 3 to 4 inches off the walking platform. Be careful to keep the walking belt centered. Plug in the power cord, insert the key and run the treadmill for a few minutes. Repeat until the walking belt is properly tightened.

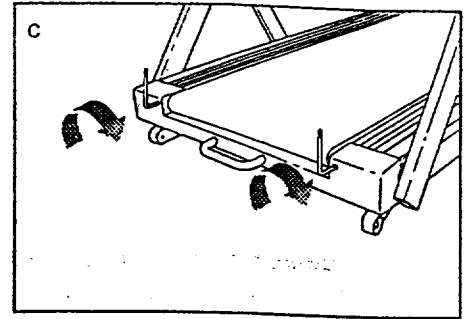

PROBLEM: The walking belt slows when walked on

SOLUTION: a. Use only a single-outlet surge suppressor that is UL 1449 listed as a transient voltage surge suppressor (TVSS). The surge suppressor must have a UL suppressed voltage rating of 400 volts or less and a minimum surge dissipation of 450 joules. The surge suppressor must be electrically rated for 120 volts AC and 15 amps.

- b. If the walking belt is overtightened, treadmill performance may decrease and the walking belt may be permanently damaged. Remove the key and **UNPLUG THE POWER CORD**. Using the allen wrench, turn both front roller adjustment bolts counterclockwise 1/4 of a turn. When the walking belt is properly tightened, you should be able to lift each side of the walking belt 3 to 4 inches off the walking platform. Be careful to keep the walking belt centered. Plug in the power cord, insert the key and run the treadmill for a few minutes. Repeat until the walking belt is properly tightened.

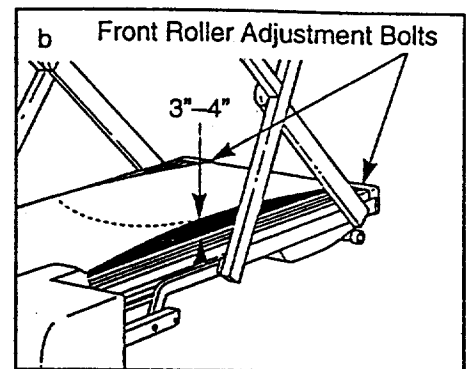

- c. If the walking belt still slows when walked on, please call our toll-free HELPLINE.

CONDITIONING GUIDELINES

⚠ WARNING: Before beginning this or any exercise program, consult your physician. This is especially important for individuals over the age of 35 or individuals with pre-existing health problems.

The pulse sensor is not a medical device. Various factors, including your movement, may affect the accuracy of heart rate readings. The sensor is intended only as an exercise aid in determining heart rate trends in general.

The following guidelines will help you to plan your exercise program. For more detailed exercise information, obtain a book or consult your physician.

EXERCISE INTENSITY

Whether your goal is to burn fat or to strengthen your cardiovascular system, the key to achieving the desired results is to exercise with the proper intensity. The proper intensity level can be found by using your heart rate as a guide. The chart below shows recommended heart rates for fat burning and aerobic exercise. (The chart is also found on the treadmill console.)

| | | | | | | | | |
|---------|-----|-----|-----|-----|-----|-----|-----|----------|
| MIN BPM | 125 | 120 | 115 | 110 | 105 | 95 | 90 | Fat Burn |
| | 145 | 138 | 130 | 125 | 118 | 110 | 103 | Max Burn |
| MAX BPM | 165 | 155 | 145 | 140 | 130 | 125 | 115 | Aerobic |
| AGE | 20 | 30 | 40 | 50 | 60 | 70 | 80 | |

To find the proper heart rate for you, first find your age at the bottom of the chart (ages are rounded off to the nearest ten years). Next, find the three numbers above your age. These numbers are your "training zone." The smaller two numbers are recommended heart rates for fat burning; the larger number is the recommended heart rate for aerobic exercise. To measure your heart rate during exercise, use the pulse sensor on the console. (See page 9.) If your heart rate is too high or too low, adjust the speed or incline of the treadmill.

Burning Fat

To burn fat effectively, you must exercise at a relatively low intensity level for a sustained period of time. During the first few minutes of exercise, your body uses easily accessible *carbohydrate calories* for energy. Only after the first few minutes does your body begin to use stored *fat calories* for energy. If your goal is to burn fat,

adjust the speed and incline of the treadmill until your heart rate is near one of the lower two numbers in your training zone. It may also be helpful to set the speed control on the console to FAT BURN to help you maintain the proper intensity level (see page 8).

Aerobic Exercise

If your goal is to strengthen your cardiovascular system, your exercise must be "aerobic." Aerobic exercise is activity that requires large amounts of oxygen for prolonged periods of time. This increases the demand on the heart to pump blood to the muscles, and on the lungs to oxygenate the blood. For aerobic exercise, adjust the speed and incline of the treadmill until your heart rate is near the higher number in your training zone. It may also be helpful to set the speed control on the console to AEROBIC to help you maintain the proper intensity level (see page 8).

High Performance Athletic Conditioning

If your goal is high performance athletic conditioning, set the speed control on the console to PERFORMANCE to help you maintain the proper intensity level (see page 8). Note: During the first few weeks of your exercise program, keep your heart rate near the low end of your training zone.

WORKOUT GUIDELINES

Each workout should include the following three parts:

A Warm-up—Start each workout with 5 to 10 minutes of stretching and light exercise. A proper warm-up increases your body temperature, heart rate, and circulation in preparation for exercise.

Training Zone Exercise—After warming up, increase the intensity of your exercise until your heart rate is in your training zone for 20 to 60 minutes. (During the first few weeks of your exercise program, do not keep your heart rate in your training zone for longer than 20 minutes.)

A Cool-down—Finish each workout with 5 to 10 minutes of stretching to cool down. This will increase the flexibility of your muscles and will help to prevent post-exercise problems.

To maintain or improve your condition, complete three workouts each week, with at least one day of rest between workouts. After a few months of regular exercise, you may complete up to five workouts each week if desired. The key to success is to make exercise a regular and enjoyable part of your everyday life.

PART LIST—Model No. 831.297940

R1197A

| Key No. | Part No. | Qty. | Description | Key No. | Part No. | Qty. | Description |
|---------|----------|------|---------------------------|---------|--------------------------|------|-----------------------------|
| 1 | 143089 | 1 | Motor Hood | 61 | 143102 | 1 | Belly Pan |
| 2 | 126996 | 16 | Hood Screw/Spacer Screw | 62 | 143103 | 1 | Right Foot Rail |
| 3 | 013576 | 26 | Hood Support Screw | 63 | 138141 | 1 | Latch Warning Decal |
| 4 | 141081 | 1 | Hood Support | 64 | 132449 | 2 | Incline Leg Pivot Bolt |
| 5 | 131738 | 1 | Storage Latch | 65 | 129639 | 1 | Console Cover |
| 6 | 141506 | 1 | Emergency Off Switch | 66 | 109265 | 2 | Belt Guide |
| 7 | 141001 | 1 | Base | 67 | 141446 138680 | 1 | Reed Switch |
| 8 | 136728 | 29 | Screw | 68 | 016028 | 1 | Wrench Clip |
| 9 | 139345 | 1 | Circuit Board | 69 | 128457 | 1 | Allen Wrench |
| 10 | 137857 | 1 | Controller | 70 | 117806 | 2 | Incline Wheel Bolt |
| 11 | 141366 | 1 | Electronics Plate | 71 | 052012 | 2 | Incline Wheel |
| 12 | 130993 | 1 | Choke | 72 | 012056 | 4 | Incline Nut |
| 13 | 124695 | 1 | Grommet | 73 | 140692 | 1 | Incline Leg |
| 14 | 124669 | 1 | Power Cord | 74 | 013162 | 4 | Roller Guard Screw |
| 15 | 143296 | 1 | Outlet Bracket | 75 | 131753 | 1 | Latch Bracket |
| 16 | 109382 | 1 | Circuit Breaker | 76 | 143288 | 1 | Console Plate |
| 17 | 126130 | 1 | Plug | 77 | 136377 | 2 | Latch Spring |
| 18 | 141168 | 4 | Right Upright Support | 78 | 141363 | 1 | Incline Motor |
| 19 | 126650 | 4 | Base Pad | 79 | 114270 | 1 | Incline Motor Spacer |
| 20 | 143092 | 1 | Wire Harness | 80 | 135622 | 2 | Link Arm Bolt |
| 21 | 013322 | 25 | Console Screw | 81 | 140137 | 1 | Hood Bracket |
| 22 | 120630 | 1 | Ground Screw | 82 | 141126 | 1 | Left Link Arm |
| 23 | 119994 | 2 | Frame Pivot Bolt | 83 | 141254 | 2 | Link Arm Spacer |
| 24 | 132314 | 2 | Front Wheel | 84 | 143106 | 1 | Speed Potentiometer |
| 25 | 119425 | 12 | Nut | 85 | 141262 | 10 | Washer |
| 26 | 130868 | 2 | Wheel Bolt | 86 | 014132 | 4 | Link Arm Washer |
| 27 | 141173 | 2 | Frame Pivot Spacer | 87 | 120867 | 1 | Motor Tension Nut |
| 28 | 141127 | 1 | Right Link Arm | 88 | 131161 | 1 | Speed Control Knob |
| 29 | 141264 | 1 | Front Endcap | 89 | 143076 | 4 | Rod Housing |
| 30 | 141370 | 1 | Switch Bracket | 90 | 143219 | 4 | Rod Housing Screw |
| 31 | 141489 | 1 | Pulley Cover | 91 | 141123 | 4 | Slider Rod |
| 32 | 119038 | 1 | Key Clip | 92 | 141026 | 2 | Slider |
| 33 | 107503 | 1 | Motor Pivot Bolt | 93 | 141382 | 2 | Lower Upright Spacer |
| 34 | 143090 | 1 | Motor | 94 | 143246 | 1 | Warning Decal |
| 35 | 139767 | 1 | Shock | 95 | 141169 | 1 | Left Upright Support |
| 36 | 012149 | 1 | Motor Pivot Nut | 96 | 141256 | 2 | Small Upright Spacer |
| 37 | 122812 | 1 | Motor Tension Washer | 97 | 141006 | 1 | Upright |
| 38 | 013547 | 3 | Motor Tension Nut | 98 | 116927 | 1 | Tie Holder |
| 39 | 118016 | 1 | Motor Bolt | 99 | 131090 | 1 | Reed Switch Clip |
| 40 | 014117 | 1 | Motor Star Washer | 100 | 116926 | 4 | Releasable Cable Tie |
| 41* | 143107 | 1 | Motor/Pulley/Flywheel/Fan | 101 | 016057 | 3 | 8" Cable Tie |
| 42 | 126747 | 1 | Pulley/Flywheel/Fan | 102 | 143104 | 1 | Console |
| 43 | 031108 | 1 | Incline Control | 103 | 140940 | 4 | Support Endcap |
| 44 | 112609 | 1 | Rear Roller Adj. Bolt | 104 | 125328 | 6 | Small Washer |
| 45 | 014063 | 3 | Adjustment Washer | 105 | 126960 | 1 | Base Plug |
| 46 | 138853 | 8 | Belly Pan Fastener | 107 | 143185 | 1 | Roller Guard |
| 47 | 100498 | 1 | Magnet | # | 139834 | 1 | 8" White Wire, Pigtail |
| 48 | 143094 | 1 | Rear Roller/Pulley | # | 137389 | 1 | 8" Blue Wire, Pigtail |
| 49 | 100691 | 4 | Walking Platform Screw | # | 139833 | 1 | 6" Blue Wire, 2 Female/Male |
| 50 | 142029 | 1 | Roller Shield | # | 141449 | 1 | 8" White Wire, Male/Female |
| 51 | 013510 | 1 | Shield Screw | # | 141453 | 1 | 8" Black Wire, Male/Flag |
| 52 | 143096 | 1 | Walking Belt | # | 141454 | 1 | 8" Black Wire, Female/Flag |
| 53 | 143098 | 1 | Walking Platform | # | 141455 | 1 | 26" Red Wire, Male/Female |
| 54 | 143099 | 1 | Left Foot Rail | # | 141457 | 1 | 22" Blue Wire, Male/Female |
| 55 | 013342 | 2 | Front Roller Adj. Bolt | # | 141456 | 1 | 22" Black Wire, Male/Female |
| 56 | 141367 | 1 | Console Base | # | 141475 | 1 | User's Manual |
| 57 | 141953 | 1 | Folding Handle | | | | |
| 58 | 143101 | 1 | Front Roller | | | | |
| 59 | 128643 | 2 | Handle Bolt | | | | |
| 60 | NSP | 1 | Frame | | | | |

* Includes all parts shown in the box
 # These parts are not illustrated

SEARS

Model No. 831.297940

QUESTIONS?

If you find that:

- you need help assembling or operating the PROFORM® 730 SIGHTLINE treadmill
- a part is missing
- or you need to schedule repair service

call our toll-free HELPLINE .

1-800-736-6879

Monday–Saturday, 7 am–7 pm
Central Time (excluding holidays)

REPLACEMENT PARTS

If parts become worn and need to be replaced, call the following toll-free number

1-800-FON-PART
(1-800-366-7278)

The model number and serial number of your PROFORM® 730 SIGHTLINE treadmill are listed on a decal attached to the frame. See the front cover of this manual to find the location of the decal.

All replacement parts are available for immediate purchase or special order when you visit your nearest SEARS Service Center. To request service or to order parts by telephone, call the toll-free numbers listed at the left.

When requesting help or service, or ordering parts, please be prepared to provide the following information:

- The NAME OF THE PRODUCT (PROFORM® 730 SIGHTLINE treadmill)
- The MODEL NUMBER OF THE PRODUCT (831.297940)
- The PART NUMBER OF THE PART (see the PART LIST on page 15 and the EXPLODED DRAWING attached in the center of this manual)
- The DESCRIPTION OF THE PART (see the PART LIST on page 15 and the EXPLODED DRAWING attached in the center of this manual).