

HITACHI

PROJECTION COLOR TV

50FX18B
50FX19K

55FX20B

OPERATING GUIDE



IMPORTANT SAFEGUARDS

2-5

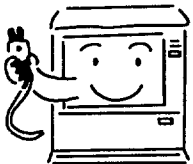

FIRST TIME USE

6-13



THE GENIUS REMOTE CONTROL

14-24

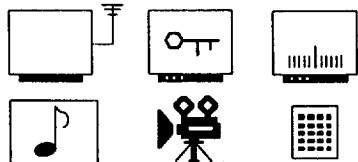

**ULTRATEC
ON SCREEN DISPLAY**

25-51

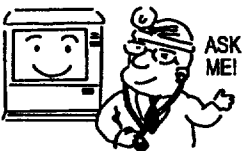





USEFUL INFORMATION INDEX

52-59



IMPORTANT

Follow all warnings and instructions marked on this television receiver.

	CAUTION RISK OF ELECTRIC SHOCK DO NOT OPEN			The lightning flash with arrowhead symbol, within an equilateral triangle, is intended to alert the user to the presence of uninsulated "dangerous voltage" within the product's enclosure that may be of a sufficient magnitude to constitute a risk of electric shock to persons.
CAUTION: TO REDUCE THE RISK OF ELECTRIC SHOCK, DO NOT REMOVE COVER (OR BACK) NO USER SERVICEABLE PARTS INSIDE REFER SERVICING TO QUALIFIED SERVICE PERSONNEL.				The exclamation point within an equilateral triangle is intended to alert the user to the presence of important operating and maintenance (servicing) instructions in the literature accompanying the appliance.

WARNING:
**TO PREVENT FIRE OR SHOCK HAZARD, DO NOT
EXPOSE THIS TELEVISION SYSTEM TO RAIN OR MOISTURE.**

NOTE:



- There are no user serviceable parts inside the receiver.
- Model number and serial number are indicated on back side of the set.

POWER SOURCE

This projection color TV is designed to operate on 120 volts 60Hz, AC household current. Insert power cord into a 120 volt 60Hz outlet.

TO PREVENT ELECTRIC SHOCK, DO NOT USE THE TELEVISION'S PLUG WITH AN EXTENSION CORD, RECEPTACLE, OR OTHER OUTLET UNLESS THE BLADES AND GROUND TERMINAL CAN BE FULLY INSERTED TO PREVENT BLADE EXPOSURE.

NEVER CONNECT THE TV TO 50 Hz, DIRECT CURRENT, OR ANYTHING OTHER THAN THE SPECIFIED VOLTAGE.

NOTE: This television receiver will display television closed captioning, ( or ), in accordance with paragraph 15.119 of the FCC rules.



CAUTION: Never remove the back cover of the set as this can expose you to very high voltages and other hazards. If the set does not operate properly, unplug the set and call your dealer or service shop.

SAFETY TIPS



IMPORTANT SAFEGUARDS

CAUTION:

- * Read all of these instructions.
- * Save these instructions for later use.
- * Follow all warnings and instructions marked on the television receiver.

SAFETY POINTS YOU SHOULD KNOW ABOUT YOUR HITACHI TELEVISION RECEIVER

Our reputation has been built on the quality, performance, and ease of service of HITACHI television receivers.

Safety is also foremost in our minds in the design of these units. To help you operate these products properly, this section illustrates safety tips which will be of benefit to you. Please read it carefully and apply the knowledge you obtain from it to the proper operation of your HITACHI television receiver.

Please fill out your warranty card at once and mail it to HITACHI. This will enable HITACHI to notify you promptly in the improbable event that a safety problem should be discovered in your model of product.

FOR YOUR PERSONAL SAFETY

1. This television set is equipped with a polarized alternating-current line plug (a plug having one blade wider than the other.) This plug will fit into the power outlet only one way. This is a safety feature. If you are unable to insert the plug fully into the outlet, try reversing the plug. If the plug should still fail to fit, contact your electrician to replace your obsolete outlet. Do not defeat the safety purpose of the polarized plug.
2. When the power cord or plug is damaged or frayed, unplug this television set from the wall outlet and refer servicing to qualified service personnel.
3. Do not overload wall outlets and extension cords as this can result in fire or electric shock.
4. Do not allow anything to rest on or roll over the power cord, and do not place the TV where the power cord is subject to traffic or abuse. This may result in a shock or fire hazard.
5. Do not attempt to service this television set yourself as opening or removing covers may expose you to dangerous voltage or other hazards. Refer all servicing to qualified service personnel.
6. Never push objects of any kind into this television set through cabinet slots as they may touch dangerous voltage points or short out parts that could result in a fire or electric shock. Never spill liquid of any kind on the television set.

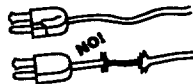

7. If the television set has been dropped or the cabinet has been damaged, unplug this television set from the wall outlet and refer servicing to qualified service personnel.

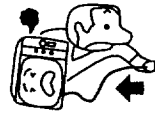

8. If liquid has been spilled into this television set, unplug it from the wall outlet and refer service to qualified service personnel.



9. Do not subject your television set to impact of any kind. Be careful not to damage the picture tube surface.



10. Unplug this television set from the wall outlet before cleaning. Do not use liquid cleaners or aerosol cleaners. Use a damp cloth for cleaning.



- 11-1. Do not place this television set on an unstable cart, stand, or table. The television set may fall, causing serious injury to a child or an adult, and serious damage to the appliance. Use only with a cart or stand recommended by the manufacturer, or sold with the television set. Wall or shelf mounting should follow the manufacturer's instructions, and should use a mounting kit approved by the manufacturer.



- 11-2. An appliance and cart combination should be moved with care. Quick stops, excessive force, and uneven surfaces may cause the appliance and cart combination to overturn.



PROTECTION AND LOCATION OF YOUR SET

12. Do not use this television set near water, for example, near a bathtub, washbowl, kitchen sink, or laundry tub, in a wet basement, or near a swimming pool, etc.
- Never expose the set to rain or water. If the set has been exposed to rain or water, unplug set from wall outlet and refer to qualified service personnel.
13. Choose a place where light (artificial or sunlight) does not shine directly on the screen.
14. Avoid dusty places, since accumulated dust inside the chassis may cause failure of the set when high humidity persists.



15. The set has slots, or openings in the cabinet for ventilation purposes, to provide reliable operation of the receiver, and to protect from overheating. These openings must not be blocked or covered.

- Never cover the slots or openings with cloth or other material.

- Never block the bottom ventilation slots of the set by placing it on a bed, sofa, rug, etc.

- Never place the set near or over a radiator or heat register.

- Never place the set in a "built-in" enclosure, unless proper ventilation is provided.





SAFETY TIPS

PROTECTION AND LOCATION OF YOUR SET

16-1. If an outside antenna is connected to the television set, be sure the antenna system is grounded so as to provide some protection against voltage surges and built up static charges, Section 810 of the National Electrical Code, NFPA No. 70-1975, provides information with respect to proper grounding of the mast and supporting structure, grounding of the lead-in wire to an antenna discharge unit, size of grounding conductors, location of antenna discharge unit connection to grounding electrode, and requirements for the grounding electrode.

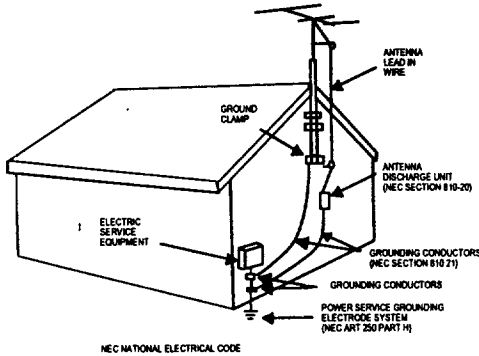

NEC NATIONAL ELECTRICAL CODE
EXAMPLE OF ANTENNA GROUNDING AS PER NATIONAL ELECTRICAL CODE INSTRUCTIONS.

16-2. **Note to CATV system installer:**
(Only for the television set with CATV reception)
This reminder is provided to call CATV system installer's attention to Article 820-40 of the NEC that provides guidelines for proper grounding and, in particular, specifies that the cable ground shall be connected to the grounding system of the building, as close to the point of cable entry as practical.

17. An outside antenna system should not be located in the vicinity of overhead power lines or other electrical lights or power circuits, or where it can fall into such power lines or circuits. When installing an outside antenna system, extreme care should be taken to keep from touching such power lines or circuits as contact with them might be fatal.



18. For added protection for this television set during a lightning storm, or when it is left unattended and unused for long periods of time, unplug it from the wall outlet and disconnect antenna. This will prevent damage due to lightning and power-line surges.



OPERATION OF YOUR SET

19. This television set should be operated only from the type of power source indicated on the marking label. If you are not sure of the type of power supply at your home, consult your television dealer or local power company. For television sets designed to operate from battery power, refer to the operating instructions.



20. If the television set does not operate normally by following the operating instructions, unplug this television set from the wall outlet and refer servicing to qualified service personnel. Adjust only those controls that are covered in the operating instructions as improper adjustment of other controls may result in damage and will often require extensive work by a qualified technician to restore the television set to normal operation.



21. When going on a holiday: If your television set is to remain unused for a period of time, turn the television set "OFF" and unplug it from the wall outlet.



IF THE SET DOES NOT OPERATE PROPERLY

22. If you are unable to restore normal operation by following the detailed procedure in your operating instructions, do not attempt any further adjustments. Unplug the set and call your dealer or service technician.



23. Whenever the television set is damaged or fails, or a distinct change in performance indicates a need for service, unplug the set and have it checked by a professional service technician.

24. It is normal for some TV sets to make occasional snapping or popping sounds, particularly when being turned on or off. If the snapping or popping is continuous or frequent, unplug the set and consult your dealer or service technician.



FOR SERVICING AND MODIFICATION

25. Do not use attachments not recommended by the television set manufacturer as they may cause hazards.

26. When replacement parts are required, be sure the service technician has used replacement parts specified by the manufacturer that have the same characteristics as the original part. Unauthorized substitutions may result in fire, electric shock, or other hazards.



27. Upon completion of any service or repairs to the television set, ask the service technician to perform routine safety checks to determine that the television is in safe operating condition.





WARNING

Continuous on-screen displays such as video games, stock market quotations, computer generated graphics, and other fixed (non-moving) patterns can cause permanent damage to projection television receivers. Such "PATTERN BURNS" constitute misuse and are NOT COVERED by your Hitachi Factory Warranty.

When using the Picture-in-Picture function, the sub-picture should not be left permanently in one corner of the screen or a "PATTERN BURN" may develop over a long period of time.

This projection television receiver was intended mainly for the private viewing of programs broadcast by TV stations and cable companies and programs from other video sources. Public viewing may require prior authorization from the broadcaster or owner of the video program.



ACCESSORIES

Check to make sure you have the following accessories before disposing of the packing material.

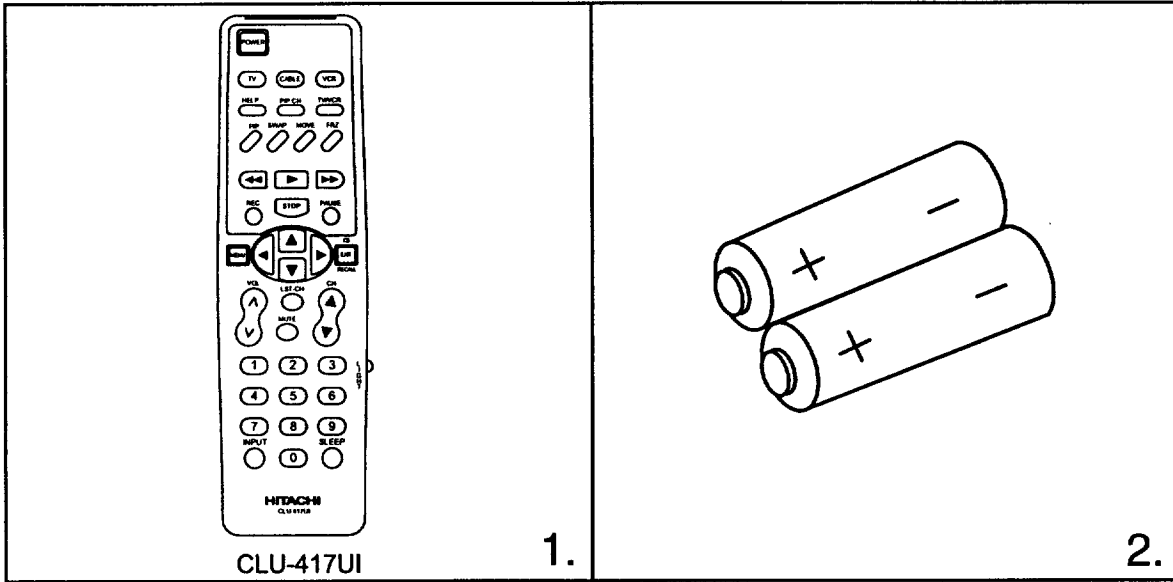

1. Remote Control Unit CLU-417UI (Part No. HL00227).
2. Two "AA" size, 1.5V batteries (For Remote Control Unit).

REMOTE CONTROL BATTERY INSTALLATION AND REPLACEMENT

1. Open the battery cover of the remote transmitter by pushing the notched part of the cover with your fingers.
2. Insert two new "AA" size batteries for the remote. When replacing old batteries, push them towards the springs and lift them out.
3. Match the batteries to the (+) and (-) marks in the battery compartment.
4. Replace the cover.

BOTTOM VIEW

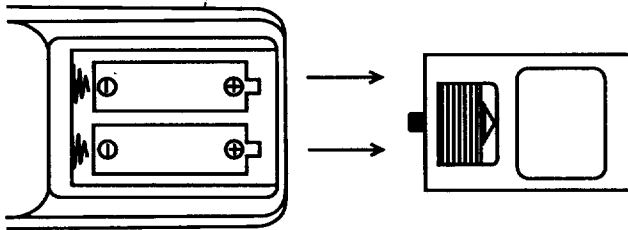

HOW TO SET UP YOUR NEW HITACHI PROJECTION TV



ANTENNA

Unless your TV is connected to a cable TV system or to a centralized antenna system, a good outdoor color TV antenna is recommended for best performance. However, if you are located in an exceptionally good signal area that is free from interference and multiple image ghosts, an indoor antenna may be sufficient.

LOCATION

Select an area where sunlight or bright indoor illumination will not fall directly on the picture screen. Also, be sure that the location selected allows a free flow of air to and from the perforated back cover of the set.

To avoid cabinet warping, cabinet color changes, and increased chance of set failure, do not place the TV where temperatures can become excessively hot. For example, in direct sunlight or near a heating appliance, etc.

VIEWING

The major benefit of the HITACHI Projection Television is its large viewing screen. To see this large screen at its best, test various locations in the room to find the best spot for viewing. The drawings give several suggestions.

The best picture is seen by sitting directly in front of the TV and about 10 to 18 feet from the screen. Picture brightness decreases as the viewer moves to the left and right of the receiver.

During daylight hours, reflections from outside light may appear on the screen. If so, drapes or screens can be used to reduce the reflection or the TV can be located in a different section of the room.

If the TV's audio output will be connected to a Hi-Fi system's external speakers, the best audio performance will be obtained by placing the speakers equidistant from each side of the receiver cabinet and as close as possible to the height of the picture screen center. For best stereo separation, place the external speakers at least 4 feet from the side of the TV, place the surround speakers to the side or behind the viewing area. Differences in room sizes and acoustical environments will require some experimentation with speaker placement for best performance.

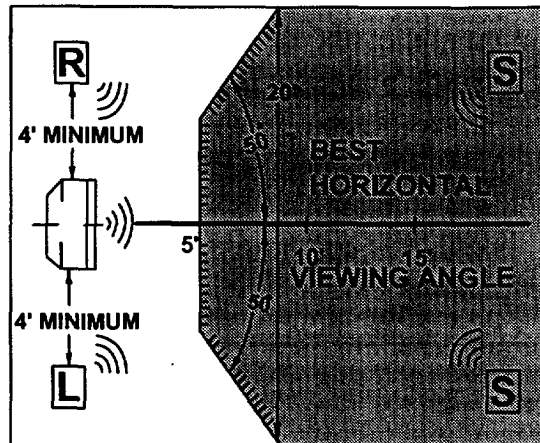
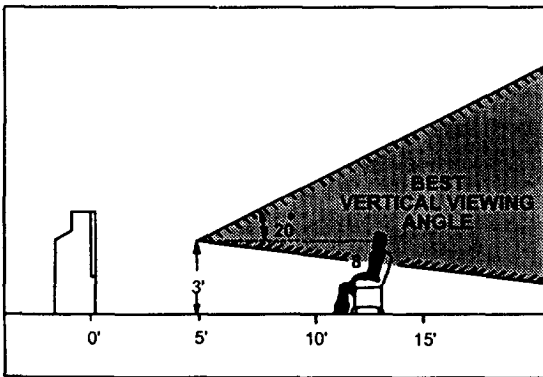

CAUTION: The magnetic field of external speakers may cause the picture to distort if the speakers are placed too close to the television. Move the speakers away from the TV until there is no picture distortion.



HOOK-UP CABLES AND CONNECTORS

Most video/audio connections between components can be made with shielded video and audio cables that have phono connectors. For best performance, video cables should use 75-Ohm coaxial shielded wire. Cables can be purchased from most stores that sell audio/video products. Below are illustrations and names of common connectors. Before purchasing any cables, be sure of the output and input connector types required by the various components. Also make sure the cables are the correct length.

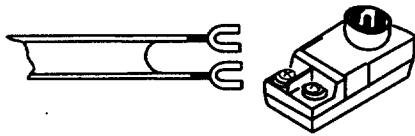

300-Ohm Twin Lead Connector

This outdoor antenna cable must be connected to an antenna adapter (300-Ohm to 75-Ohm).



"F" Type 75-Ohm Coaxial Antenna Connector

For connecting RF signals (antenna or cable TV) to the antenna jack on the television.



Phono Connector

Used on all standard video and audio cables which connect to inputs and outputs located on the Television's rear jack panel and front control panel.



S-Video (Super Video) Connector

This connector is used on camcorders, VCR's and laser disc players with an S-Video feature in place of the standard video cable to produce a high quality picture.

ANTENNA CONNECTIONS TO REAR JACK PANEL

VHF (75-Ohm) antenna/CATV (cable TV)

When using a 75-Ohm coaxial cable system, connect the outdoor antenna or CATV coaxial cable to the ANT A (75 Ohm) terminal. If you have a second antenna or cable TV system, connect the coaxial cable to the ANT B terminal.

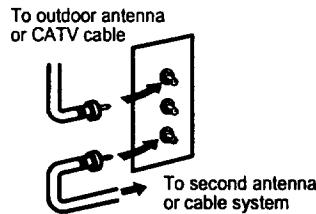

VHF (300-Ohm) antenna/UHF antenna

When using a 300-Ohm twin lead from an outdoor antenna, connect the VHF or UHF antenna leads to screws of the VHF or UHF adapter. Plug the adapter into the antenna terminal on the TV.

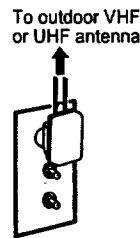

When both VHF and UHF antennas are connected

Attach an optional antenna cable mixer to the TV antenna terminal, and connect the cables to the antenna mixer. Consult your dealer or service store for the antenna mixer.

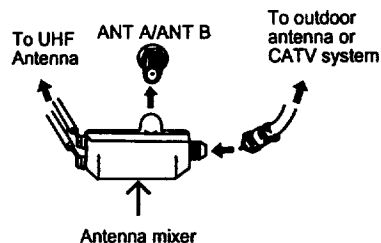

FRONT PANEL CONTROLS



FRONT VIEW

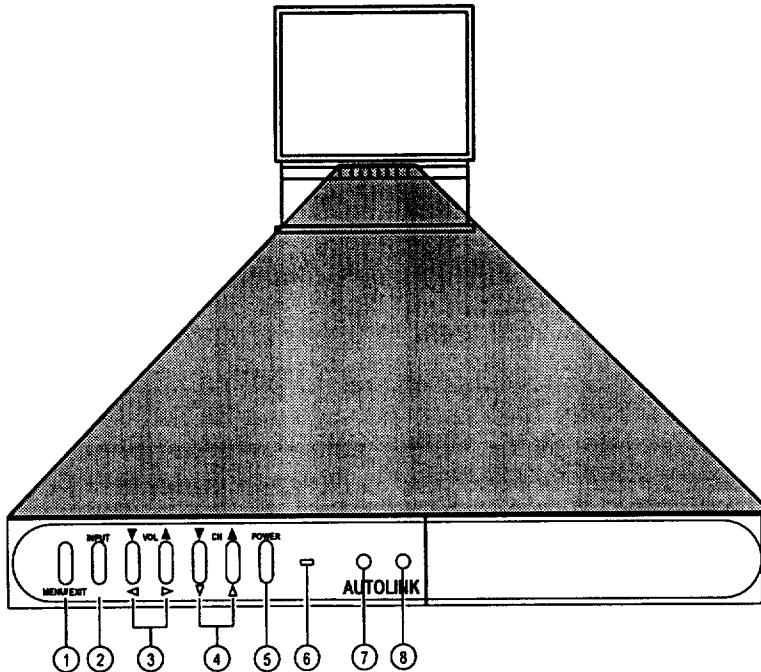

- ① **MENU/EXIT button**
This button allows you to enter the MENU mode without using the remote. This makes it possible to set TV features to your preference, without using the remote. This button also serves as the EXIT button when in MENU mode.
 - ② **INPUT selector**
Press this button to select the current antenna source, VIDEO: 1, 2, or alternate antenna source. Your selection is shown in the top right corner of the screen.
 - ③ **VOLUME level**
Press these buttons for your desired sound level. The volume level will be displayed on the TV screen. These buttons also serve as the cursor left and right buttons when in MENU mode.
 - ④ **CHANNEL selector**
Press these buttons until the desired channel appears in the top right corner of the TV screen. These buttons also serve as the cursor down and up buttons when in MENU mode.
 - ⑤ **POWER button**
Press this button to turn the TV on or off.
 - ⑥ **POWER light**
You will see a red light when the TV is turned on.
- NOTE:** Your HITACHI TV will appear to be turned "OFF" if there is no video input when VIDEO: 1 or 2 is selected. Check the Power Light to make sure the TV is off when not in use.
- ⑦ **AI (Artificial Intelligence) sensor**
This Artificial Intelligence sensor will make automatic picture adjustments depending on the amount of light in the room to give the best picture. (See page 45.)
 - ⑧ **REMOTE CONTROL sensor**
Point your Remote at this area when selecting channels, adjusting volume, etc.



REAR PANEL JACKS

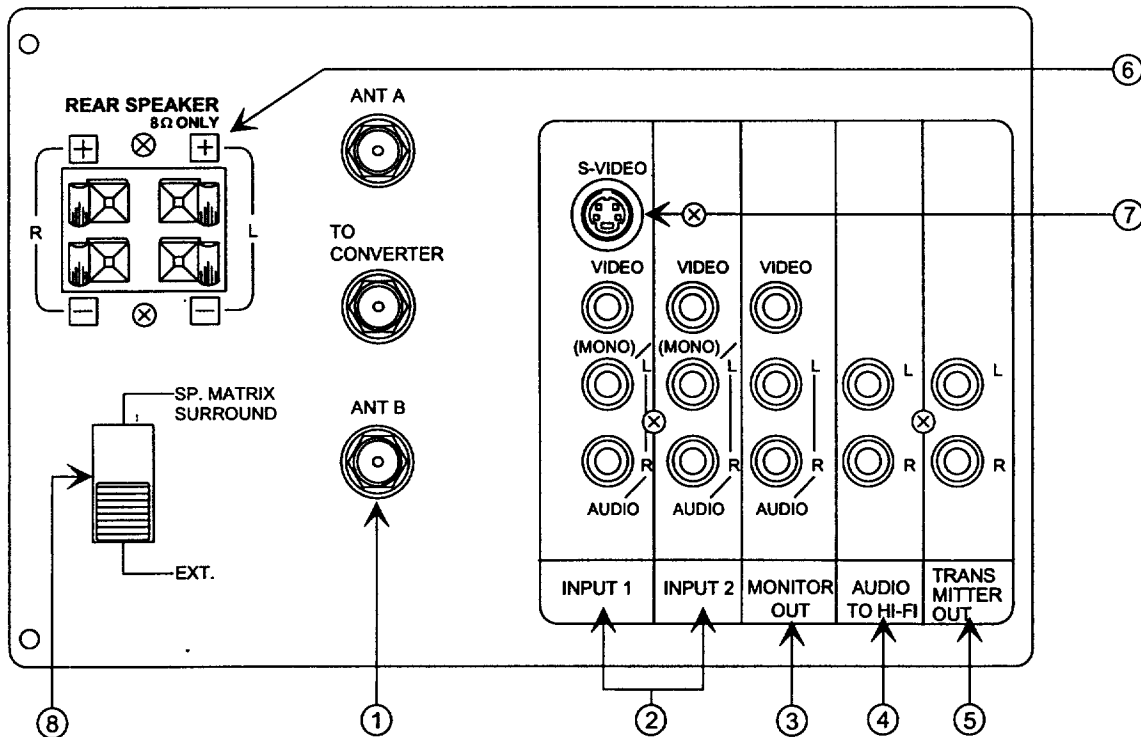

1 Antenna Input/Output

The remote control allows you to switch between two separate 75-Ohm RF antenna inputs, ANT A and ANT B. ANT A input can be displayed as a Main Picture or Sub-Picture. ANT B can only be displayed as a Main Picture. (ANT B cannot be displayed as a PIP sub-picture.) The antenna output labeled "TO CONVERTER" allows the ANT A connection to pass directly to a different source such as a cable box.

2 Audio/Video Inputs 1, 2

The "INPUT" button will step through each video source and antenna source input each time it is pressed. Use the audio and video inputs to connect external devices, such as VCR's, camcorders, laser disc players, etc. (If you have mono sound, insert the audio cable into the left channel jack.)

3 Monitor Out

These jacks provide fixed audio and video signals which are used for recording.

4 Audio to Hi-Fi

These jacks provide variable audio output to a separate stereo system amplifier. With this connection, the audio to the stereo can be controlled by the television's main volume.

5 Transmitter Out

These jacks provide variable audio output to a set of wireless speakers. They can also be used for another stereo system amplifier. With this connection, the audio can be controlled by the television's remote control.

6 Rear Speaker Terminals

These terminals are used to connect external speakers, which are used for the surround sound feature. The volume level is controlled by the remote control main volume buttons. Use speakers with 8 Ohm impedance only.

7 S-Video

Input 1 provides S-Video (Super Video) jacks for connecting equipment with S-Video output capability.

8 Speaker Matrix Surround Switch

Use this switch to choose between the surround and external speaker features. See page 13 for Audio System Setup. The TV's internal speakers will be switched off when "EXT." is selected.

REAR PANEL CONNECTIONS

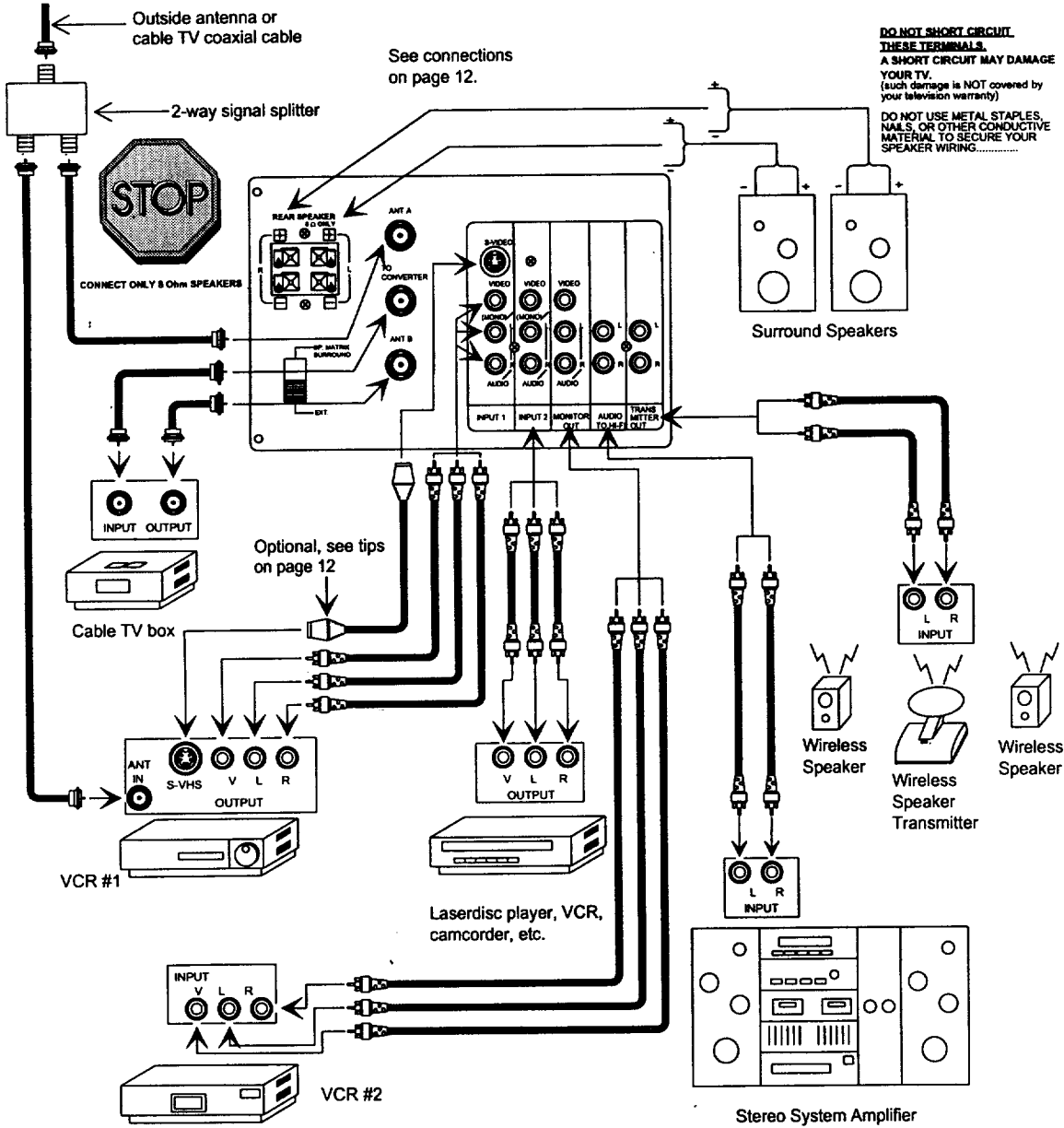

Typical full feature set-up. Follow connections that pertain to your personal entertainment system.



REAR SPEAKER TERMINAL CONNECTIONS

Connect after turning the power to the TV OFF.

Press the Right Speaker red button and insert the positive (+) lead wire into the hole next to the button. Once the wire is in place, pull the red button back to original position and the wire is locked into place. In the same manner, press the Right Speaker black button and insert the negative(-) lead wire. Repeat this procedure for the Left Speaker.



CAUTION: Do not short speaker terminals, (do not connect a wire directly across any two terminals). This could cause damage to your audio outputs or damage your TV in other ways.

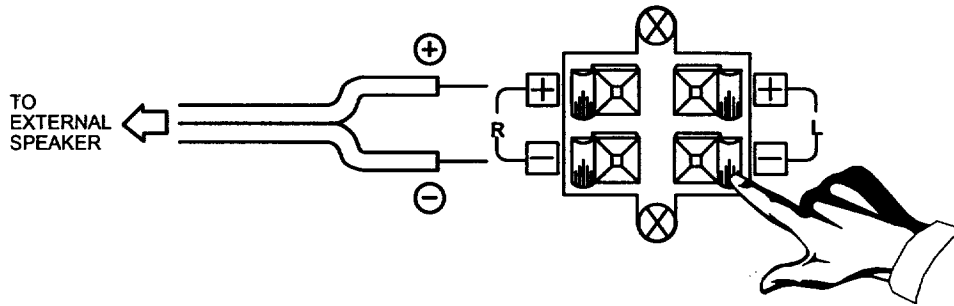

CAUTION: Do not connect speakers simultaneously to the REAR SPEAKER terminal of the Projection TV and an external amplifier. This could damage both the TV and the speakers. Your TV was designed to use 8 Ohm speakers only. Any other type may degrade the audio performance of your entertainment system.

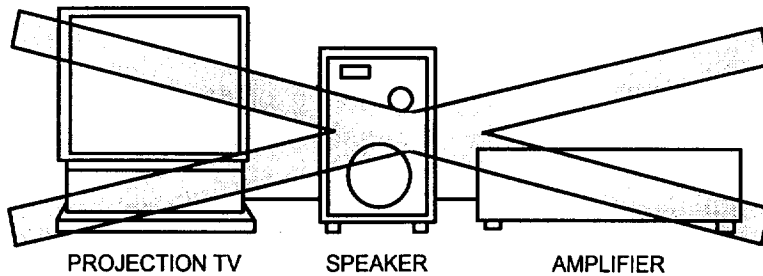

PROJECTION TV

SPEAKER

AMPLIFIER

TIPS ON REAR PANEL CONNECTIONS

The S-Video connection is provided for high performance laser discs, VCR's etc., that have this feature. Use this connection in place of the standard video connection if your device has this feature.

If your device has only one audio output (mono sound), connect it to the left audio jack on the TV.

Refer to the operating guide of your other electronic equipment for additional information on connecting your hook-up cables.

A single VCR can be used for VCR #1 and VCR #2, but note that a VCR cannot record its own video or line output (INPUT: 1 in the example on page 11.) Refer to your VCR operating guide for more information on "line" input-output connections.

AUDIO SYSTEM SETUP



Match the numbers below to the diagram for speaker placement and refer to the table for the different surround sound requirements.

- ① The television's internal speakers.
- ② These speakers are connected to a separate audio amplifier. Use the "AUDIO TO HI-FI" output on the TV.
- ③ These speakers are connected to the Rear Speaker 8 Ohm output on the TV.
- ④ These speakers are controlled by a wireless speaker transmitter. Use the "TRANSMITTER OUT" output on the TV.

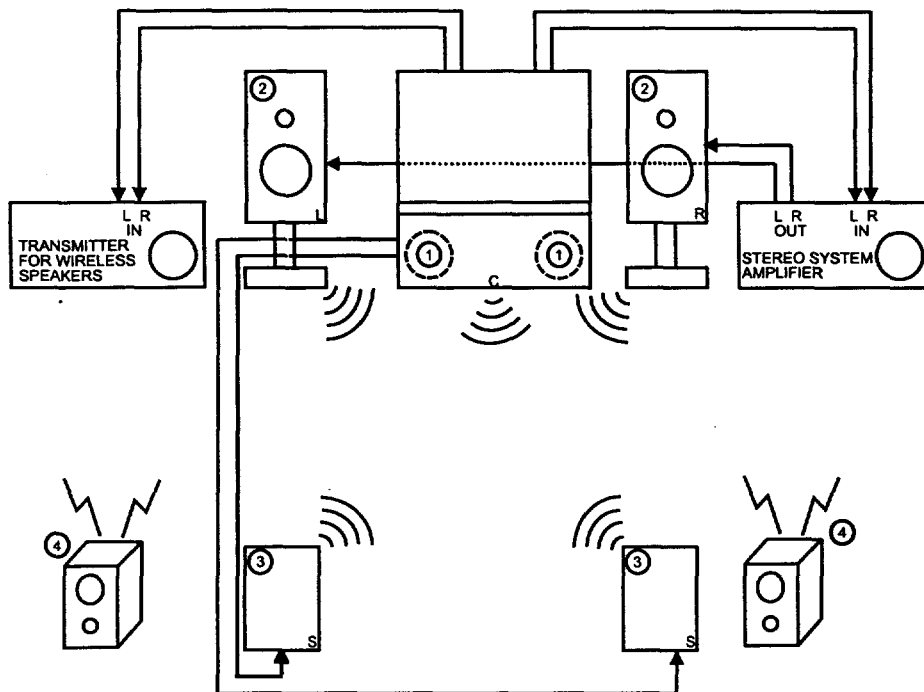

SURROUND FEATURE	SURROUND SWITCH*	REQUIRED CONNECTION	OPTIONAL CONNECTION	EFFECT
OFF	Sp. Matrix Surround	①	② ④	Receive Mono and Stereo sound
MATRIX	Sp. Matrix Surround	① ③	② ④	Receive Movie Theater-like sound.
EXTERNAL SPEAKERS	EXT.	②	③ ④	This feature turns off the TV's internal speakers.

* See page 10 for location of Surround Switch.



THE GENIUS REMOTE CONTROL (CLU-417UI)

In addition to controlling all the functions on your HITACHI Color TV, the new remote is designed to operate different types of VCR's and CATV (Cable TV)/Satellite converters with one touch. Basic operation keys are grouped together in one area.

To operate your TV, point the remote at the remote sensor of the TV and press the TV button on the remote. The remote will now control your TV.

To operate your VCR, point the remote at the remote sensor of the VCR, and press the VCR button on the remote. The remote will now control your VCR. (See page 22 for instructions on how to program the remote to control your VCR.)

To operate your Cable/Satellite Box, point the remote at the remote sensor of the cable/satellite box and press the CABLE button on the remote. The remote will now control your cable/satellite box. (See page 23 for instructions on how to program the remote to control your cable/satellite box.)

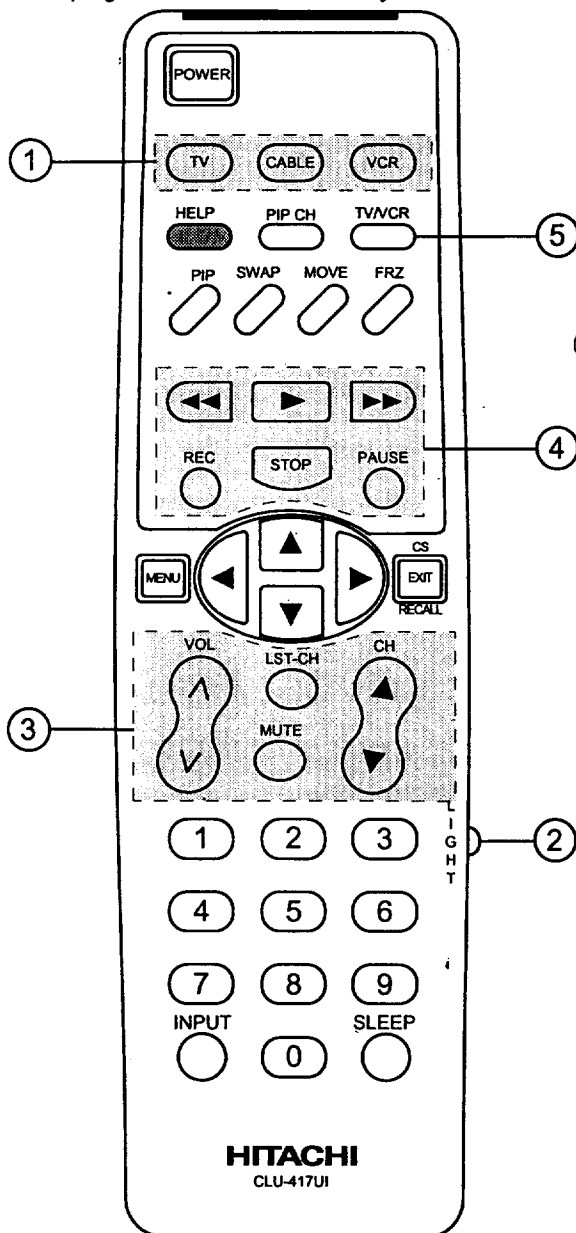

① These buttons allow the remote to control your TV, VCR, or Cable Box depending on which mode is chosen, as explained above.

②, ③ **LIGHT BUTTON**
When you are in a dark room, press this button on the side of the remote to light up the buttons shown in ③. The light will stay on for about 8 seconds if the light button is not pressed again. These buttons will not appear to light if the room is too bright.

④ **PRECODED VCR BUTTONS**
These buttons always transmit the chosen pre-coded VCR codes.

⑤ **TV/VCR BUTTON**
When the remote is in the TV or VCR mode, this is the TV/VCR button. When the remote is in the CABLE mode, this is the A/B button.

HOW TO USE THE GENIUS REMOTE TO CONTROL YOUR TV



1 TV POWER button

Press this button to turn the TV set on or off.
If a Special Event Reminder is set, it will be displayed when the TV is first turned on.
(See page 50.)

2 EXIT/RECALL/COMMERCIAL SKIP button

Press this button when no menu is displayed when you want to check the channel being received, or if it has stereo (ST) or second audio program (SAP).

You can also check the time, CHANNEL ID, and if the SLEEP TIME has been set.
(See pages 18, 33, and 35.)

When in MENU mode, this button will exit all On Screen Displays.

Press this button twice quickly, when no menu is displayed, to enable the COMMERCIAL SKIP function. This will tune the TV to the last channel viewed and after 30 seconds, tune back to the original channel.

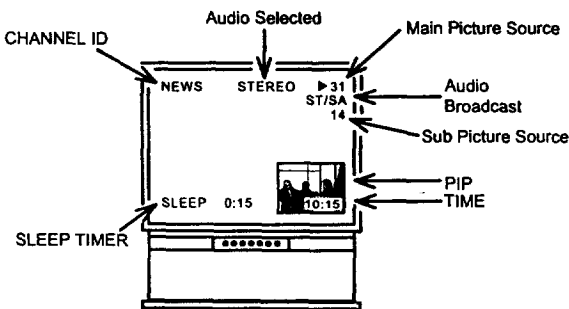

If a video input is used:

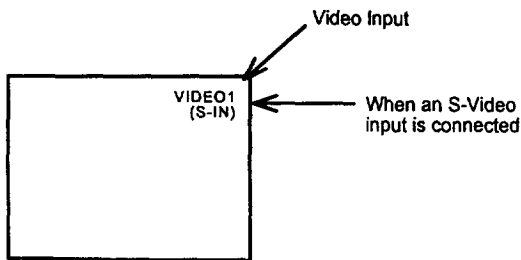

You can also use the RECALL button to quickly clear many of the other on-screen displays.

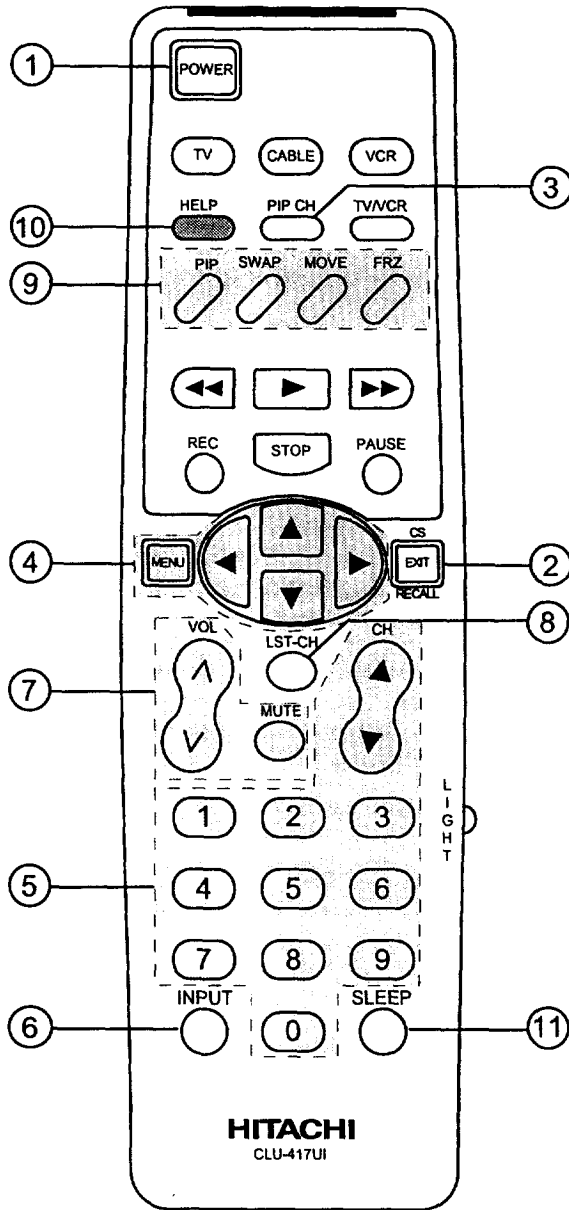

HOW TO USE THE GENIUS REMOTE TO CONTROL YOUR TV

- 3 PIP CH button**
Use the PIP CH button to select between main picture and sub-picture tuning. An arrow next to the channel number will indicate which channel is being controlled.
- 4 MENU, CURSOR buttons**
All the On-Screen Display features can be set or adjusted by using these buttons.
The "MENU" button will start the On-Screen Display.
The "CURSOR" buttons will highlight functions or adjust and set different features.
- 5 CHANNEL SELECTOR buttons**
"CHANNEL SELECTOR" buttons are used to set Family Favorites, Channel Memory, etc..
Enter two or three numbers to select channels. Enter "0" first for channels 1 to 9. For channels 100 and above, press the "1" button, wait until another dash appears next to the channel display on your TV, then enter the remaining two numbers using the number buttons.
Channel selection may also be performed by pressing CH up (▲) or down (▼).
You may also use these buttons for QUICK LIST. Press and hold the CH up (▲) or down (▼) button and a window will appear, allowing you to choose the channel you wish to tune. Release the CH (▲) or (▼) button when the channel you wish to tune is highlighted, and the TV will tune to that channel.

NOTE: The TV may not receive some channels if you are not in the correct SIGNAL SOURCE mode. (See page 29.)

- 6 INPUT button**
The INPUT button will select between both antenna signals and the two sets of video input jacks each time the button is pressed. If the Picture-in-Picture is on, the INPUT button will select between the two sets of video input jacks and both antenna sources when main channel is chosen with the PIP CH button. If the sub-picture is chosen, the INPUT button will select between the two sets of video input jacks and the ANT A antenna source (ANT B source cannot be displayed as a PIP Sub-Picture.)

NOTE: When ANT A is selected, the channel number in the upper right corner of the screen is in green. When ANT B is selected, the channel number is in yellow.

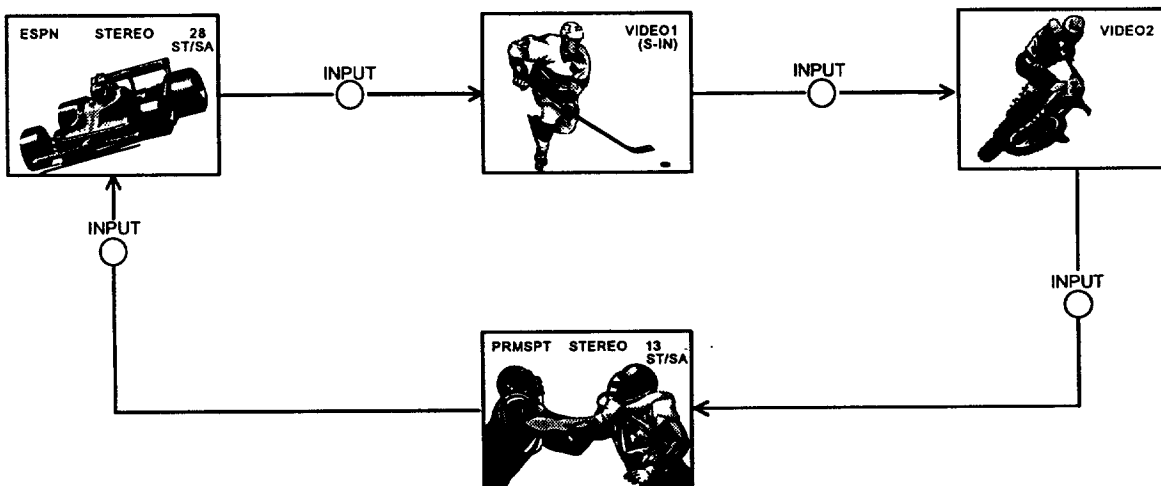

HOW TO USE THE GENIUS REMOTE TO CONTROL YOUR TV



7 VOLUME, MUTE buttons

Press the "VOLUME" up (▲) or down (▼) button until you obtain the desired sound level.

To turn the sound off instantly to answer the telephone, etc., press the "MUTE" button. Press the "MUTE" button again or press the "VOLUME" up (▲) button to restore the sound.

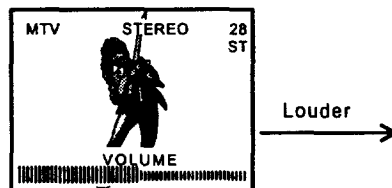

Closed Caption will appear when TV is muted, regardless of CLOSED CAPTIONED on/off.



8 LAST CHANNEL (LST-CH) button

Use this button to select between the last two channels viewed. (Good for watching two sporting events, etc.)

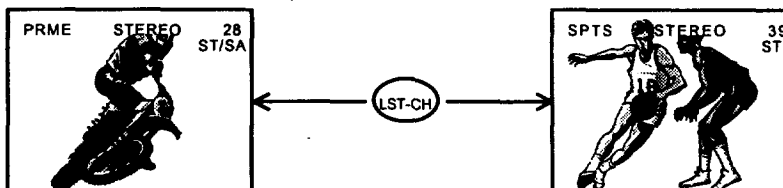

9 PICTURE-IN-PICTURE

See separate section on page 19 for a description.



HOW TO USE THE GENIUS REMOTE TO CONTROL YOUR TV

10 HELP button

Press this button when a menu is displayed to view HELP text, which gives a description of the displayed menu.

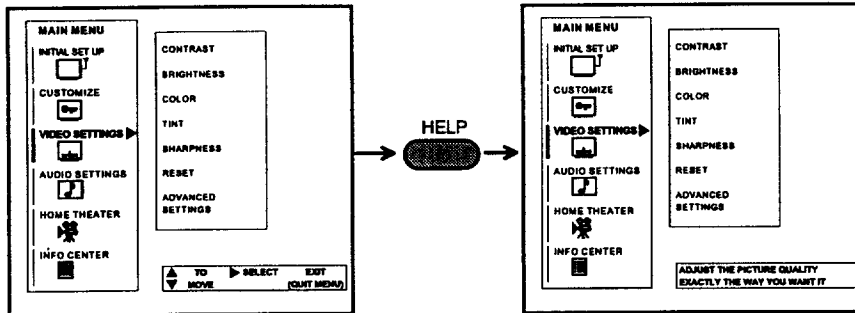

11 SLEEP button

Press this button to display the sleep timer in the lower left corner of the screen. Every subsequent press of this button will add 15 minutes to this timer, up to a maximum of 3 hours. Once set, use RECALL when you want to view time remaining. If the SLEEP button is pressed while the timer is set, it will reset to the original condition.

PICTURE-IN-PICTURE (PIP)



Your Hitachi Projection TV incorporates Dual Tuner technology designed to give you improved viewing enjoyment. This Dual Tuner feature allows you to view antenna inputs on both MAIN and PIP sub-pictures simultaneously, with separate tuning control for each. The Dual Tuner can operate with only one input (ANT A only) or two inputs (ANT A and ANT B).

ANT A input can be viewed as both main picture and sub-picture, simultaneously. ANT B can only be viewed as a Main Picture. To select between Main Picture and PIP sub-picture tuning, press the PIP CH button on the remote. The arrow next to the channel display will move with every press of the PIP CH button. When the arrow is next to the top channel display, channel tuning is for the Main Picture. When the arrow is next to the lower channel display, channel tuning is for the PIP sub-picture. This method of picture tuning is the same for one antenna input (ANT A only) and two antenna inputs (ANT A and ANT B).

The Picture-in-Picture feature is convenient when you want to watch more than one program at the same time. You can watch a TV program while viewing other programs from the ANT A source or any of the video inputs.

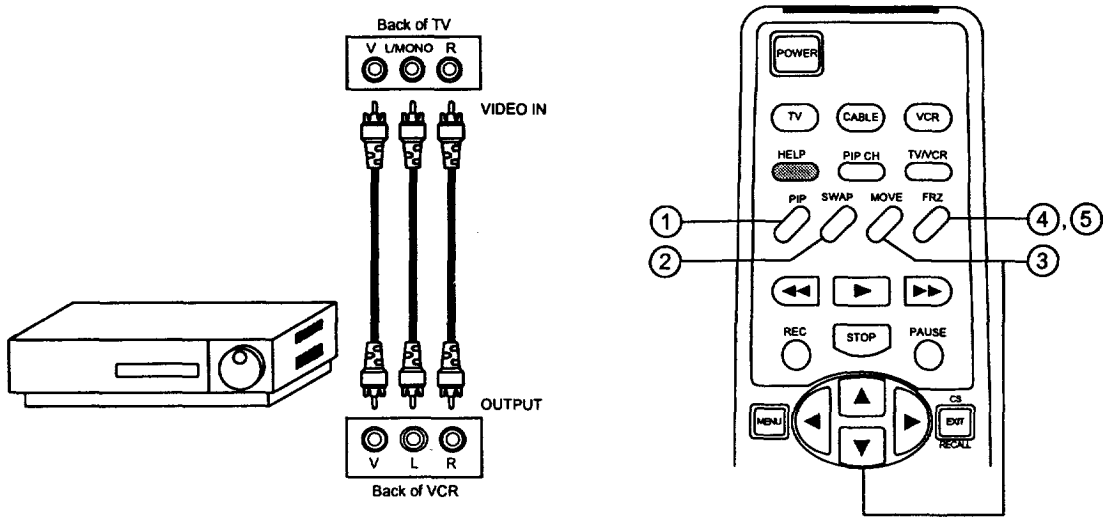

① PIP button

Press the "PIP" button and a screen appears which allows you to use CURSOR ▲, ▼ to select which type of PIP you wish to view.

SINGLE MODE PIP

Press the "PIP" button a second time and a sub-picture appears in one corner of the screen. Press the button again to reduce the size of the sub-picture. Press the "PIP" button a fourth time to remove the sub-picture from the screen. Use the "PIP CH" button to select between Main and Sub-Picture tuning control (indicated by arrow next to channel number.) Press the INPUT button when sub-picture channel tuning is being controlled, to change between VIDEO: 1, VIDEO: 2, and ANT A antenna source. (ANT B source cannot be viewed as a sub-picture.)

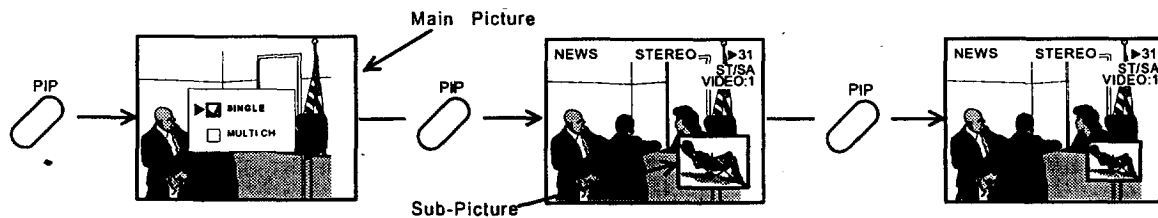

NOTE: Since ANT B source cannot be viewed as a sub-picture, only single PIP mode is possible when ANT B is selected as the Main Channel.



PICTURE-IN-PICTURE (PIP)

PICTURE-IN-PICTURE CONT.

MULTI CH PIP

Press the "PIP" button a second time to begin Multi-Channel PIP. This feature will automatically scan through all active channels (those set in memory) and display them as PIP sub-pictures, along the right edge of the screen. Press the "PIP" button a third time to remove the sub-pictures from the screen.



- NOTE:**
1. If no buttons are pressed when in MULTI-CHANNEL PIP mode, autoscanning will continuously scan.
 2. If a channel is tuned during this MULTI-CHANNEL scanning, sub-pictures will be removed from the screen.

② SWAP button

If you wish to switch what is being shown on the main picture to the sub-picture, press the "SWAP" button.

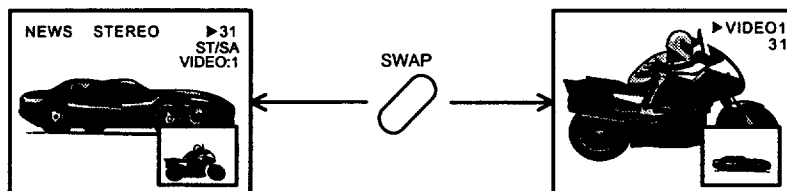

- NOTE:** The SWAP button will only operate when SINGLE PIP mode is chosen. The SWAP function will not operate if ANT B input is set as the main channel (ANT B input cannot be displayed as a sub-picture).

③ MOVE button

To move the sub-picture to another corner, press the "MOVE" button. The sub-picture moves one step counter-clockwise every time the "MOVE" button is pressed. (Example below illustrates the "MOVE" operation for initial shipping conditions. If you have customized a PIP position, the "MOVE" operation may differ slightly from this example.)

It is also possible to customize one PIP position. To do this, simply use the remote control CURSOR buttons while the sub-picture is displayed, to shift the sub-picture to a position you prefer.

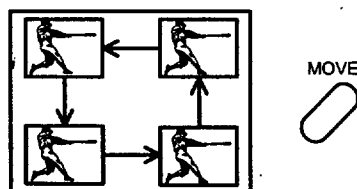

- NOTE:** The MOVE and CUSTOMIZING PIP position functions will only operate when SINGLE PIP mode is chosen.

PICTURE-IN-PICTURE (PIP)



④ FREEZE (FRZ) button (With PIP ON)

If you wish to freeze the sub-picture, press the "FRZ" button. This is convenient when trying to write down the address for a mail order company, recording statistics for a sporting event, etc. To return the picture to motion, press the button again.

NOTE: The FREEZE function will only operate when SINGLE PIP mode is chosen.

⑤ FREEZE (FRZ) button (With PIP OFF)

Press the "FRZ" button without a sub-picture and a screen appears which allows you to use CURSOR ▲, ▼ to select which type of FREEZE mode you wish to view.

SINGLE FREEZE

Press the "FRZ" button a second time to freeze one frame of the picture you are currently viewing. Press this button again or "PIP" to return to normal viewing.



STROBE FREEZE

Press the "FRZ" button a second time to freeze four frames of the picture you are currently viewing. Press this button again or "PIP" to return to normal viewing. This feature is useful for viewing a moving picture that has many details, for example, a close play in a sporting event or golf swing.



CAUTION: A pattern burn may develop if the sub-picture is left in the same corner permanently. If the PIP feature is used frequently, occasionally shift the sub-picture to a different corner. You may also vary its position using the CURSOR buttons.

- NOTE:**
1. Only sound from the main picture can be heard, unless you choose sub-picture audio from HOME THEATER-WIRELESS SOUND mode and use the "TRANSMITTER OUT" outputs on the rear panel. (See page 49.)
 2. Each freeze frame is delayed about 0.1 (1/10) second.



USING THE GENIUS REMOTE TO CONTROL VCR FUNCTIONS

Operating the pre-coded function for your VCR.

This remote is designed to operate different types of VCR's. You must first program the remote to match the remote system of your VCR. (Refer to page 24.)

1. Turn ON your VCR.
2. Aim the remote control at the front of your VCR.
3. While holding down the VCR button on the remote, enter the 2 digit preset code that matches your VCR as shown on page 24. The remote will turn off your VCR when the correct 2 digit preset code is entered. When this occurs, the remote control is programmed for your VCR. If the VCR does not turn off after 5 seconds, try a different 2 digit preset code.
4. The remote will now control your VCR.

NOTES:

1. If your VCR cannot be operated after performing the above procedures, this means that your VCR's code has not been precoded into the remote.
2. In the unlikely event that your VCR cannot be operated after performing the above procedures, please consult your VCR operating guide.
3. The remote control will remember the codes you have programmed in until the batteries are removed from the remote control. After replacing the batteries repeat the entire programming procedure stated above.
4. If your VCR does not have a power function, the remote will issue the CHANNEL UP function.
5. The MENU button will act as the VCR MENU button for HITACHI VCR's.
6. The EXIT button will act as your VCR ENTER button if required.
7. The INPUT button will act as your VCR +100 button if required.

- ① **VCR button**
This button allows the remote to control your VCR by setting it to VCR mode.
- ② **PRECODED VCR buttons**
These buttons transmit the chosen precoded VCR codes.
- ③ **EXCLUSIVE TV buttons**
These buttons are for operating the TV.

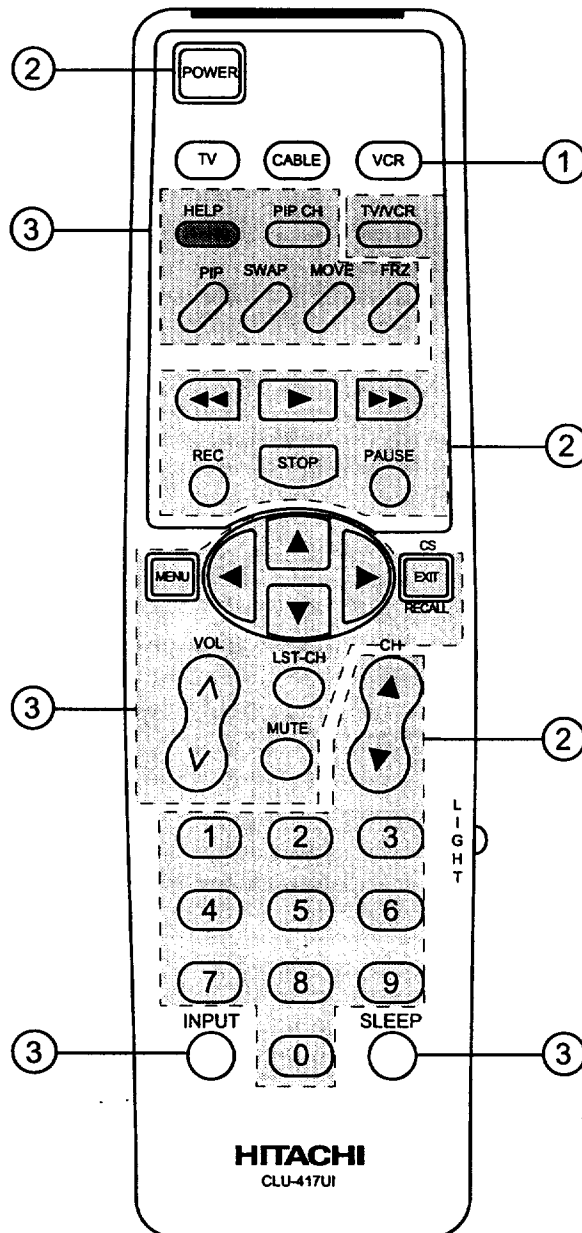

USING THE GENIUS REMOTE TO CONTROL CABLE/SATELLITE BOX FUNCTIONS



Operating the pre-coded function for your cable/satellite box.

This remote is designed to operate different types of cable boxes and Digital Satellite Systems. You must first program the remote to match the remote system in your cable/satellite box. (Refer to page 24.)

1. Turn ON your cable/satellite box.
2. Aim the remote control at the front of your cable/satellite box.
3. While holding down the CABLE button on the remote, enter the 2 digit preset code that matches your cable/satellite box as shown on page 24. The remote will turn off your cable/satellite box when the correct 2 digit preset code is entered. When this occurs, the remote control is programmed for your cable/satellite box. If the cable/satellite box does not turn off after 5 seconds, try another 2 digit preset code.
4. The remote will now control your cable/satellite box.

NOTES:

1. If your cable/satellite box cannot be operated after performing the above procedures, this means that your cable/satellite box code has not been pre-coded into the remote.
2. In the unlikely event that your cable/satellite box cannot be operated after performing the above procedures, please consult your cable/satellite box operating guide.
3. The remote control will remember the codes you have programmed in until the batteries are removed from the remote control. After replacing the batteries repeat the entire programming procedure stated above.
4. If your cable/satellite box does not have a power function, the remote will issue the CHANNEL UP function.
5. The EXIT button will act as the cable/satellite box ENTER button if required
6. The INPUT button will act as your cable/satellite box +100 button if required.

- ① **CABLE button**
This button allows the remote to control your cable box by setting it to CABLE mode.
- ② **PRECODED CABLE/SATELLITE BOX buttons**
These buttons transmit the chosen pre-coded CABLE/Satellite codes.
- ③ **EXCLUSIVE TV buttons**
These buttons are for operating the TV.

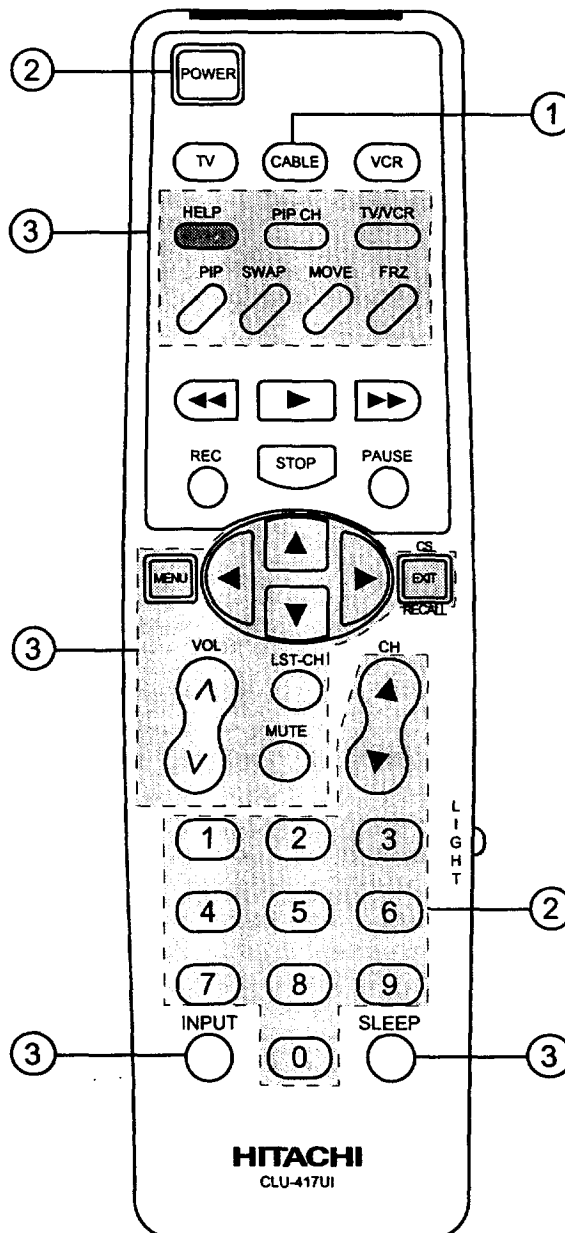



CABLE AND VCR CODES

CABLE BRAND	CODES	SATELLITE BRAND	CODES	VCR BRAND	CODES
ABC	.01, 03, 05, 06, 09, 11, 12, 14, 30	General Instrument	.61	(cont.)	
Antronix	.44	Jerrold	.61, 62	MGN Technology	.48
Archer	.28, 40, 44	Primestar	.61, 62	Minolta	.15, 31
Belcor	.31	RCA	.60	Mitsubishi	.16, 23, 26, 36, 49
Cable Star	.31	Sony	.63	Motorola	.09, 20
Century	.40			MTC	.00, 48
Citizen	.40	TELEVISION BRAND	CODES	Multitech	.00, 27
Colour Voice	.19, 25	Hitachi	.00	NEC	.11, 13, 14, 26, 30
Comtronics	.29, 34	Megatron	.00	Nikko	.10
Contec	.15			Noblex	.48
Dae Ryung	.06	VCR BRAND	CODES	Olympus	.09, 47
Eastern	.02	Adventura	.00	Optimus	.10, 20, 30
Electricord	.37	Aiko	.50	Orion	.51
Everquest	.13	Aiwa	.00	Panasonic	.09, 35, 46, 47, 53
Focus	.57	Akai	.14, 23, 49	Penney	.09, 10, 11, 13, 15, 21, 48
Garrard	.40	American High	.09	Pentax	.15, 24, 31
GC Electronics	.31, 44	Asha	.48	Philco	.09
Gemini	.13, 32, 36, 46	Audiovox	.10	Philips	.09, 28, 32
General Instrument	.09, 51	Beaumarck	.48	Pilot	.10
GoldStar	.29, 39	Bell & Howell	.30	Pioneer	.26
Hamlin	.08, 16, 27, 49, 50	Brandt	.38	Portland	.05
Hitachi	.09	Broksonic	.33, 37, 43, 51, 52	Protec	.27
Hytex	.05	Calix	.10	Pulsar	.12
Jasco	.40	Canon	.09	Quarter	.18
Jerrold	.03, 09, 10, 12, 13, 30, 51	Capehart	.05	Quartz	.18
Macom	.26	Carver	.28	Quasar	.09
Magnavox	.21	CCE	.27, 50	Radio Shack	.00, 10
Memorex	.00	Citizen	.10, 50	Radix	.10
Movie Time	.35, 37, 42	Colt	.27	Randex	.10
NSC	.35, 36, 42	Craig	.10, 19, 27, 48	RCA	.15, 22, 24, 31, 34, 39
Oak	.05, 15, 47	Curtis Mathes	.09, 14, 22	Realistic	.00, 09, 10, 18, 19, 20, 25, 30, 48
Panasonic	.00, 17, 38	Cybernex	.48	Ricoh	.08
Paragon	.00	Daewoo	.03, 05, 17, 29, 50	Runco	.12
Philips	.19, 21, 22, 23, 24, 25, 40, 46, 54	Daytron	.05	Samsung	.17, 48
Pioneer	.18, 39, 65	Dynatech	.00	Sanky	.12, 20
Popular Mechanics	.57	Electrohome	.10	Sansui	.14, 26
Pulsar	.00	Electroponic	.10	Sanyo	.18, 19, 30, 48
RCA	.17	Emerex	.06	Scott	.16, 17, 33, 37, 43, 44
Realistic	.44	Emerson	.00, 01, 10, 16, 23, 33, 37, 40, 41, 43, 44, 50, 51, 52	Sears	.09, 10, 15, 18, 19, 21, 25, 30, 31
Recoton	.57	Fisher	.19, 21, 25, 30	Sharp	.20
Regal	.16, 49, 50, 53	Fuji	.07, 09	Shintom	.27
Regency	.02	Funai	.00	Shogun	.48
Rembrandt	.09, 36	Garrard	.00	Singer	.27
Runco	.00	GE	.09, 22, 24, 39	Sony	.06, 07, 08, 09
Samsung	.29, 39	Goldstar	.04, 10, 11	STS	.15
Scientific Atlanta	.04, 06, 14, 52	Gradiente	.00	Sylvania	.00, 09, 16, 28, 32
Signal	.13, 29	Harley Davidson	.00	Symphonic	.00
Signature	.09	Harman/Kardon	.11	Tatung	.14
SL Marx	.29	Harwood	.27	Teac	.00, 14
Sprucer	.17, 55	Headquarter	.18	Technics	.09, 35
Starcom	.03, 13, 30	HI-Q	.19	Teknika	.00, 09, 10
Stargate	.13, 29	Hitachi	.14, 15, 24, 31	Telefunken	.38
Starquest	.13	Jensen	.14	TMK	.40, 48
Starsight	.58, 59	JVC	.02, 14, 26	Toshiba	.16, 17, 25, 44
Sylvania	.01	KEC	.10, 50	Totevision	.10, 48
Televue	.29	Kenwood	.11, 14, 26	Unitech	.48
Texscan	.01	KLH	.27	Vector	.17
Tocom	.10, 11, 33	Kodak	.9, 10	Vector Research	.11, 13
Toshiba	.00	Lloyd	.00	Video Concepts	.13, 17, 23
Tusa	.13	Lloyd's	.40	Videosonic	.48
TV86	.35	Logik	.27	Wards	.00, 09, 15, 19, 20, 22, 27, 34, 44, 48
Unika	.40, 44	LXI	.10	XR-1000	.00, 09, 27
United Artists	.05	Magnavox	.09, 12, 28, 32, 34	Yamaha	.11
United Cable	.03	Magnin	.48	Zenith	.07, 08, 12
Universal	.28, 31, 37, 40, 43, 44	Marantz	.09, 28		
Videoway	.48	Marta	.10		
Viewstar	.21, 34, 35, 45	Matsushita	.09		
Zenith	.00, 64	MEI	.09		
Zentek	.57	Memorex	.00, 09, 10, 12, 18, 19, 20, 30, 48		
		MGA	.16, 23		

ULTRATEC OSD



1. Press MENU on the remote control to display the different features on your HITACHI Projection TV.
2. Press the CURSOR buttons to highlight a different feature.
3. Press EXIT on the remote control to quickly exit from a menu.
4. Press HELP on the remote control when a menu is displayed, and text will appear giving a description of that menu.

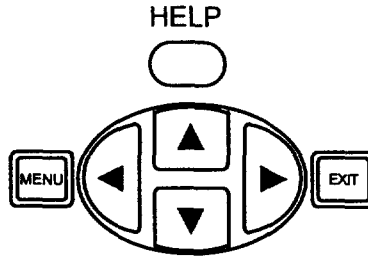

This part of the screen shows what selections are available.

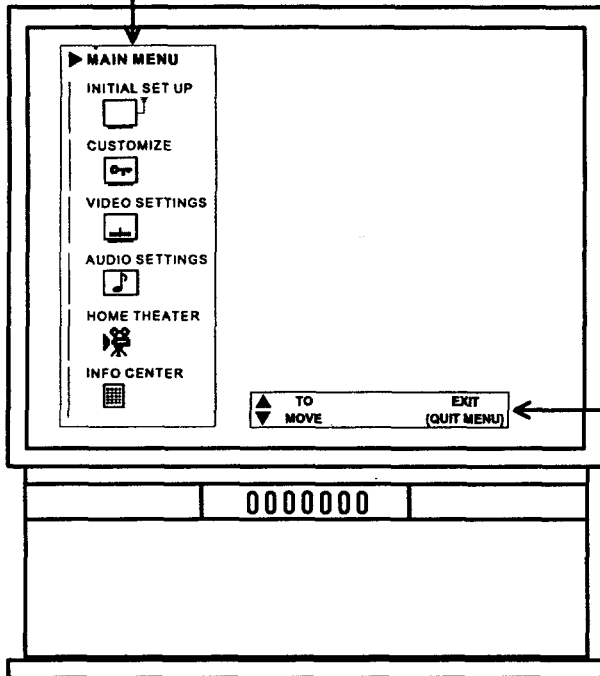

This part of the screen shows which remote control buttons to use.



ULTRATEC OSD

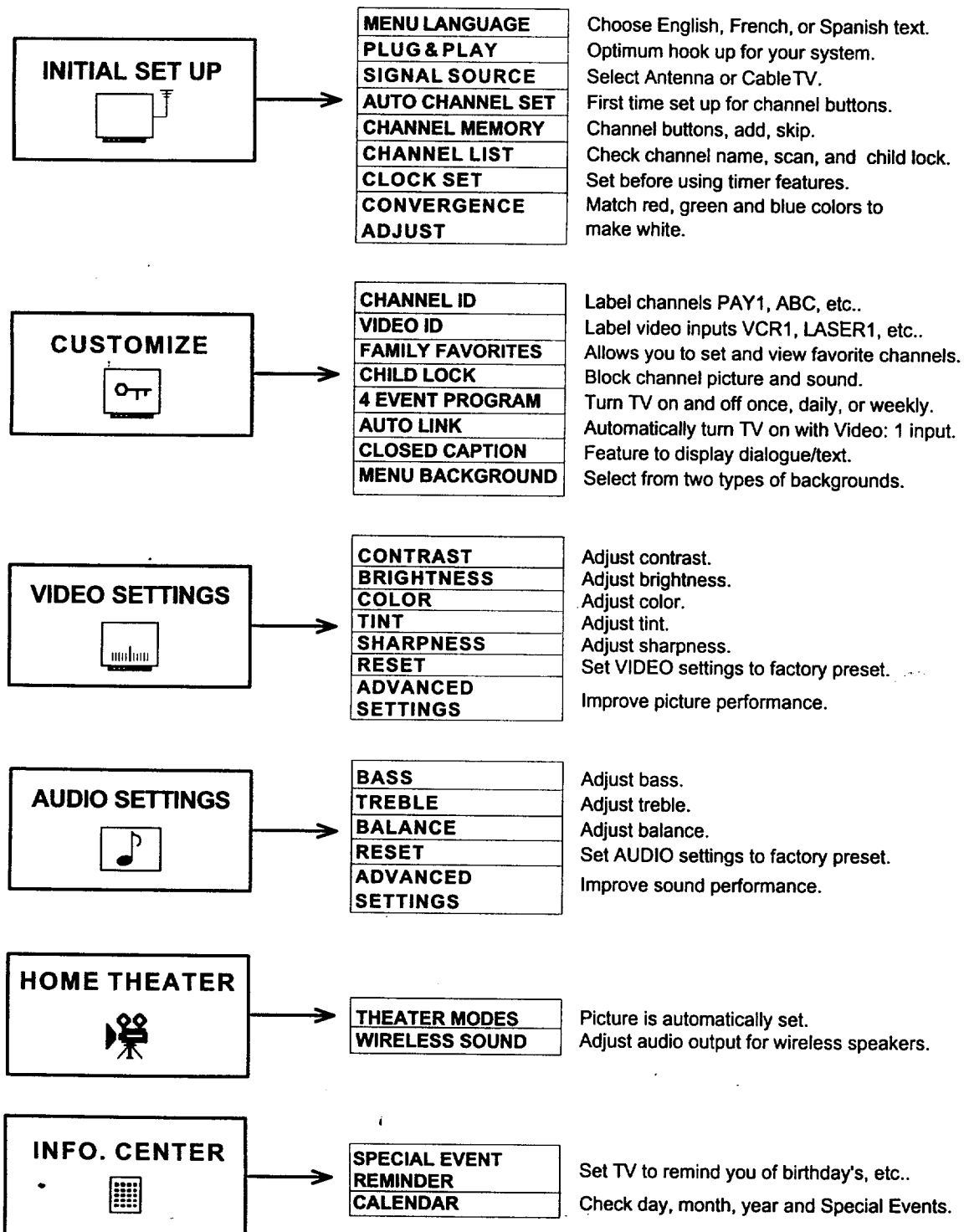

INITIAL SETUP



Select INITIAL SETUP when setting your TV up for the first time. Use the CURSOR ▲, ▼ buttons on the remote to highlight the function desired.

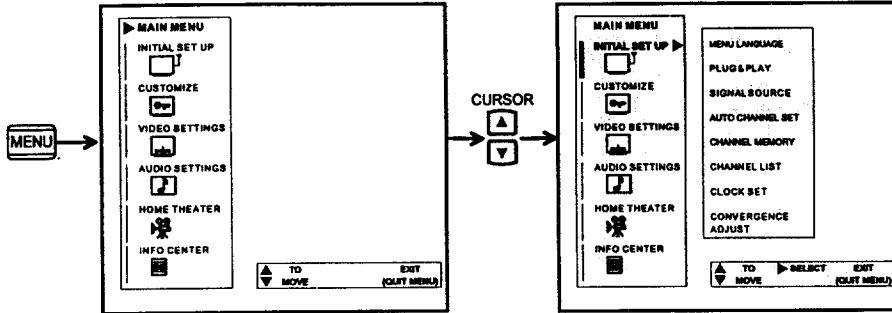

NOTE: To see an autodemonstration of the on-screen display with HELP text displayed, press and hold the POWER button on the TV set for approximately 5 seconds. Press the POWER button on the TV again to end the autodemonstration.

MENU LANGUAGE

This feature will allow you to select any one of 3 different languages for all on screen displays.

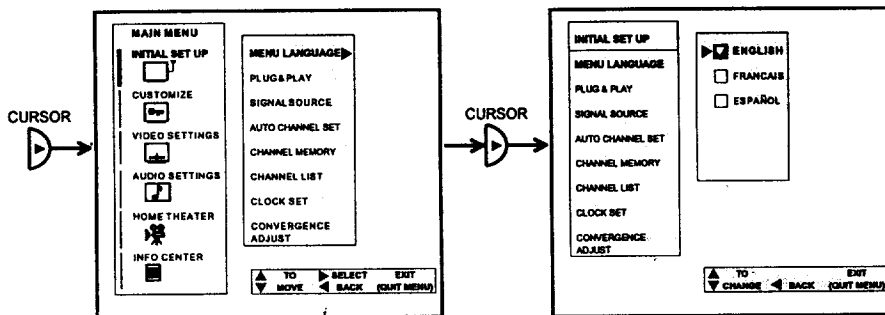

Use CURSOR ▲ or ▼ to select the MENU LANGUAGE of your choice.

Press EXIT to quit menu or CURSOR ◀ to return to previous menu.



INITIAL SETUP

PLUG & PLAY

This graphic guide function will help you to properly set up your TV or Home Theater System. Simply answer two questions and a graphic will be displayed, showing you the optimum setup for your personalized system.

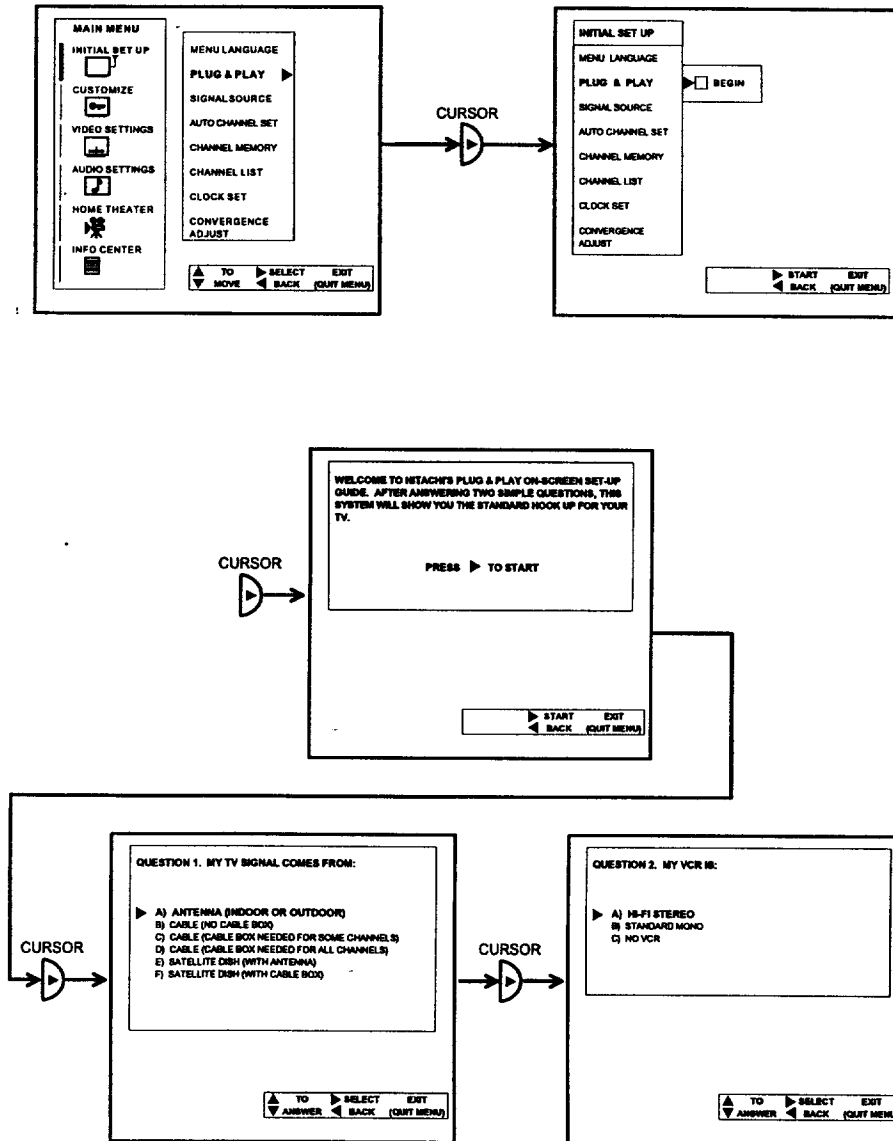

Press CURSOR ▲ or ▼ to highlight the correct answers to both questions.
 Press CURSOR ► to display the graphic guide.
 Press EXIT to quit menu or CURSOR ► to begin AUTO CHANNEL SET. (See page 30.)

INITIAL SETUP



SIGNAL SOURCE

Select ANTENNA if you are using an indoor or outdoor antenna. Select CATV if you have cable TV.

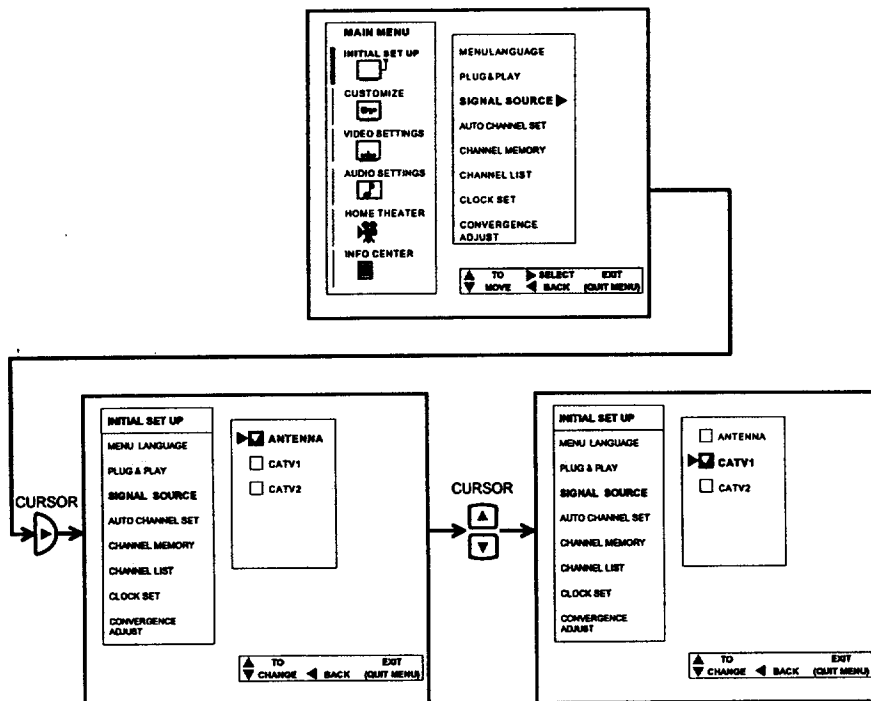

Press CURSOR ▲ or ▼ to highlight and select the correct SIGNAL SOURCE mode. Press EXIT to quit MENU or CURSOR ◀ to return to previous menu.

RECEPTION BAND		
AIR	CATV 1 OR CATV 2	
	CATV CHANNEL	Indicated on the screen
VHF 2 ~ 13ch UHF 14 ~ 69ch	VHF 2 ~ 13	2 ~ 13
	Mid band A ~ I	14 ~ 22
	A-5 ~ A-1	95 ~ 99
	Super Band J ~ W	23 ~ 36
	Hyper band W + 1 ~ W + 28	37 ~ 64
	Ultra band W + 29 ~ W + 84	65 ~ 125

Reception channels for each mode are shown at the left.

Refer to your cable or TV guide for channel identification standards.

If certain CATV channels are poor or not possible in CATV1 mode, set SIGNAL SOURCE to CATV2.



INITIAL SETUP

AUTO CHANNEL SET

This feature will automatically store active TV channels in CHANNEL MEMORY. This will allow you to skip over unused channels when using the CHANNEL UP (▲) or DOWN (▼) buttons.

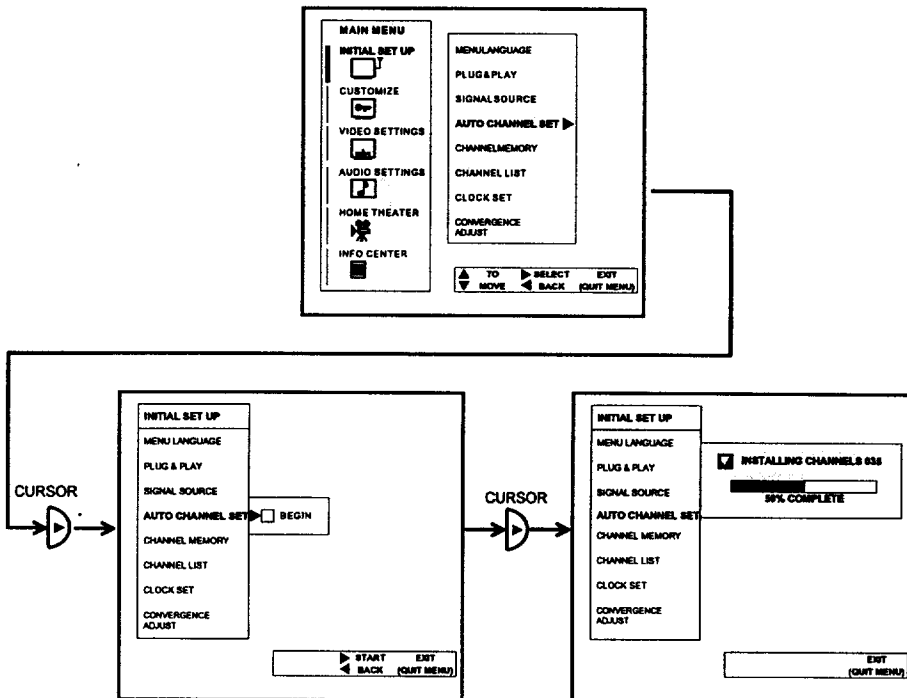

If the EXIT button is pressed while the AUTO CHANNEL SET function is engaged, programming will stop. If two antennas are connected, switch antenna inputs with the INPUT button and repeat AUTO CHANNEL SET for the second antenna input.

Remember to select the correct SIGNAL SOURCE mode before using AUTO CHANNEL SET for the second antenna input.

See CHANNEL MEMORY to add or erase additional channels.

INITIAL SETUP



CHANNEL MEMORY

Use this function after AUTO CHANNEL SET to add or erase additional channels to the remote control CHANNEL ▲ or ▼ buttons.

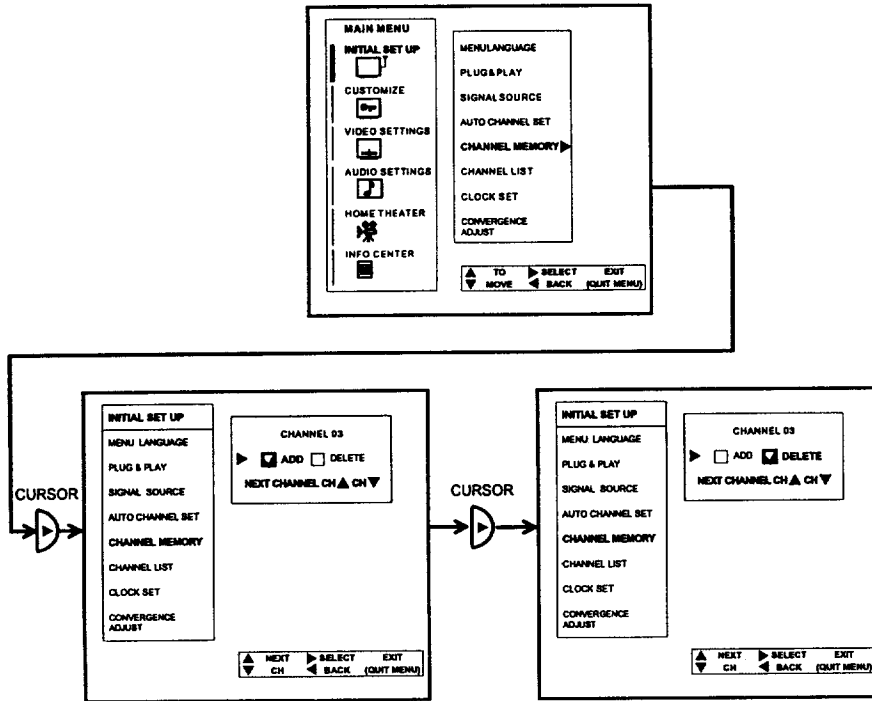

Add or erase additional channels while still in CHANNEL MEMORY using CURSOR ▲ or ▼, CHANNEL ▲ or ▼, and number buttons and then add or erase using the CURSOR ► button.

Press EXIT to quit menu or CURSOR ◀ to return to previous menu.



INITIAL SETUP

CHANNEL LIST

This function allows you to review which channels are labeled in CHANNEL ID (NAME), which have been added to CHANNEL MEMORY (SCAN), and which are protected by CHILD LOCK (LOCK).

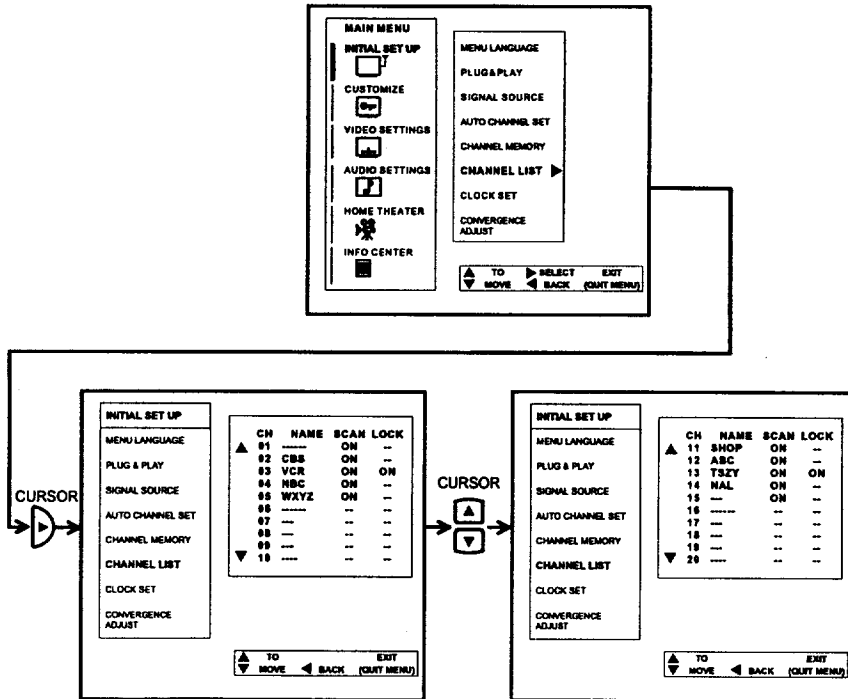

Press CURSOR ▲ or ▼ to review more channels.
Press EXIT to quit menu or CURSOR ◀ to return to previous menu.

INITIAL SETUP



CLOCK SET

The time must be set before you can use 4 EVENT PROGRAM, SPECIAL EVENT REMINDER, or CALENDAR.

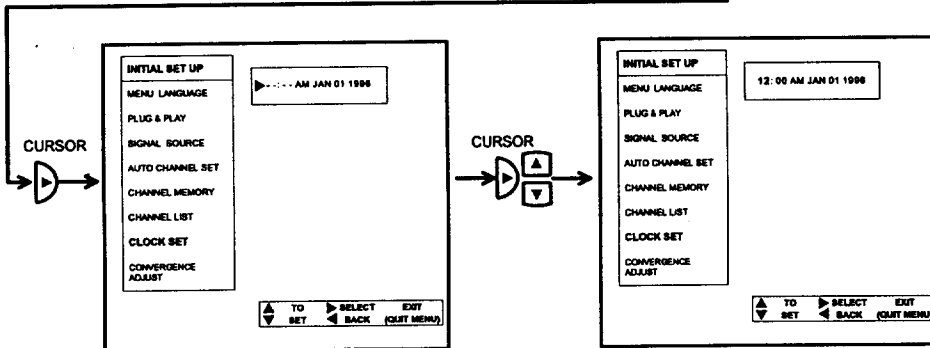
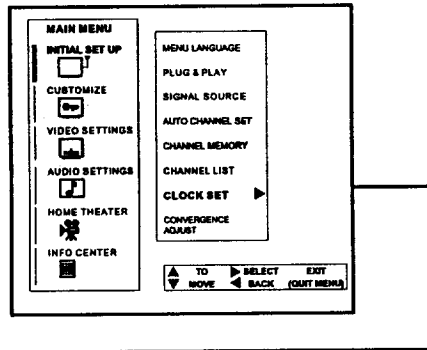

Use CURSOR ▲ or ▼ buttons to set the time, date, and year.
Press CURSOR ► to change position.
Press EXIT to quit menu or CURSOR ◀ to return to previous menu.



INITIAL SETUP

CONVERGENCE ADJUST

Your projection TV has three color projection tubes: one for red, one for green, one for blue. When mixed together in the proper proportion, the output of these three color tubes can produce any color. To produce these colors, however, the beams must be precisely aligned over each other so that the colors can be mixed. The process of aligning these picture beams is called "convergence".

Over a period of time, the picture tubes can drift out of alignment due to normal bumps and vibrations or moving the TV. If you move your TV, or if, after a time, you notice color rings or halos around objects in the picture, you may want to converge (align) the colors.

To simplify convergence, the following feature allows you to display a test pattern of horizontal and vertical lines on the screen. Properly converged, the lines appear white, which is actually a combination of the outputs of the three color tubes. The output of the green tube is stationary. The outputs of the red and blue tubes can be adjusted. When properly aligned, the outputs of all three tubes should be directly over each other to produce the white lines.

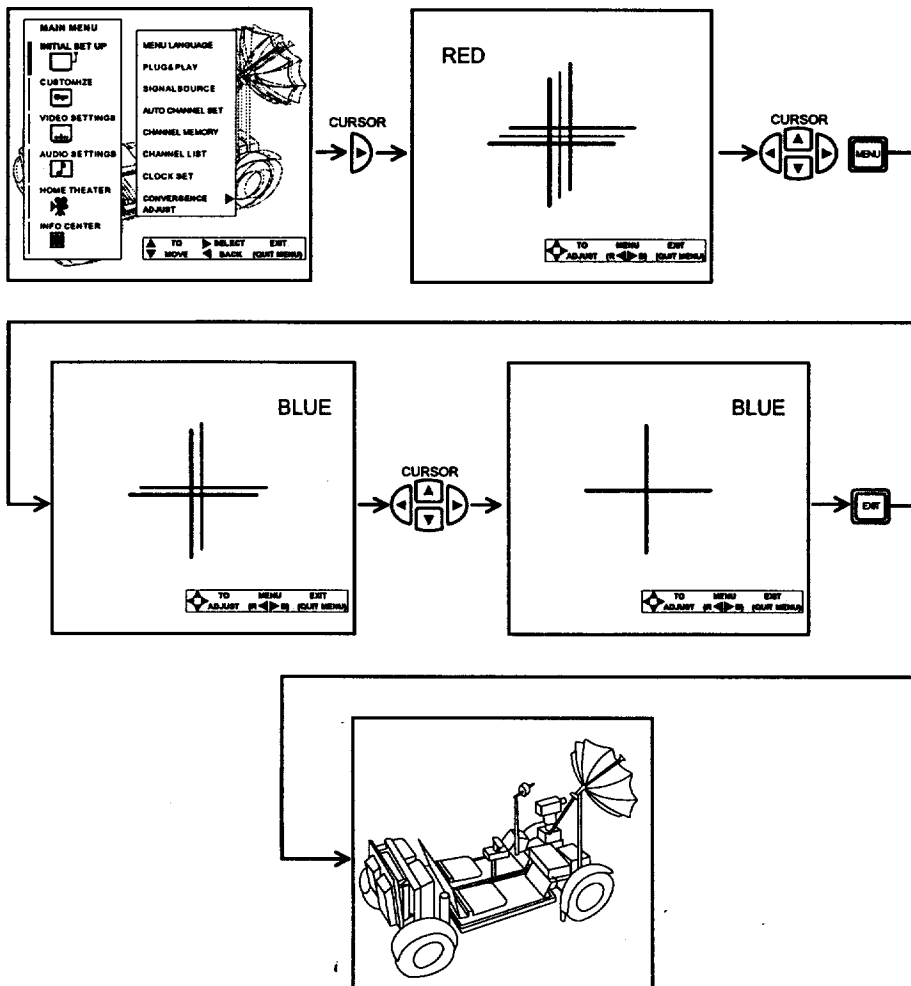

Press the CURSOR ▲ or ▼ to move the color displayed up or down
Press CURSOR ◀ or ▶ to move the color displayed left or right.
Press MENU to change the color.
Press EXIT to quit menu.

NOTE: Please use the EXIT button on your remote to quit this menu. To quit this menu without a remote, turn the TV off.

CUSTOMIZE



CUSTOMIZE

This selection contains advanced features which will make TV viewing easier and more enjoyable.

CHANNEL ID

Use this feature to give up to 20 channels a name when ANTENNA signal source is selected and up to 60 channels a name when CATV1 signal source is selected.

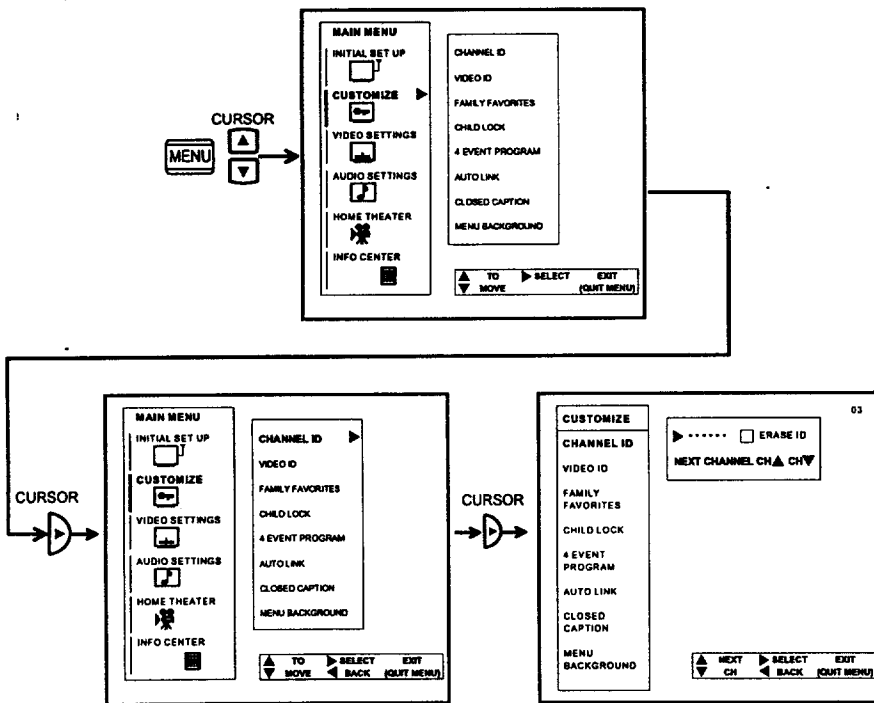

- Press CURSOR ▲ or ▼ to select letters.
- Press CURSOR ► to change character position.
- Press CURSOR ▲ or ▼, CHANNEL ▲ or ▼, and the number buttons to select and label additional channels. The CHANNEL ID will now appear in the top left corner of the screen.
- Press EXIT to quit menu or CURSOR ◀ to return to previous menu.

The (*) represents a blank space.
 Select ERASE ID to erase a CHANNEL ID.

NOTE: If ANT A and ANT B are in the same SIGNAL SOURCE mode (see page 29), the CHANNEL ID for both antenna inputs will be the same.
 CHANNEL ID will be displayed only when channel is displayed as main picture.



CUSTOMIZE

VIDEO ID

Use this feature to give a name to any of the 2 video inputs.

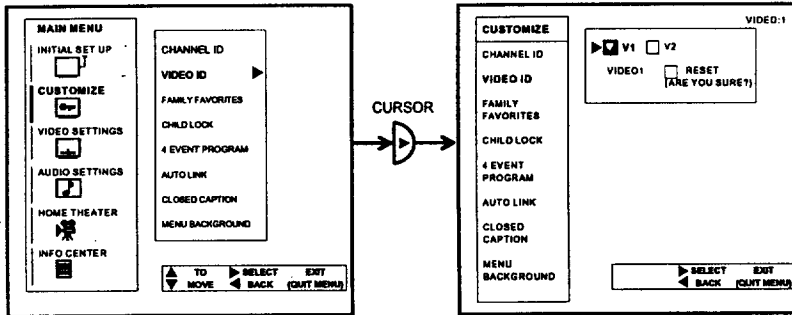

- Press CURSOR ► to select the video input to be renamed.
- Press CURSOR ▲ or ▼ to select letters.
- Press CURSOR ► to change position.
- Press EXIT to quit menu or CURSOR ◀ to return to previous menu.

The (*) represents a blank space.
Select RESET to set VIDEO ID to original condition.

NOTE: VIDEO ID will be displayed only when VIDEO input is displayed as main picture.

CUSTOMIZE



FAMILY FAVORITES (MENU)

This function allows you to group your favorite channels into 6 personalized categories that you can rename. A total of 24 channels can be stored in the FAMILY FAVORITES function.

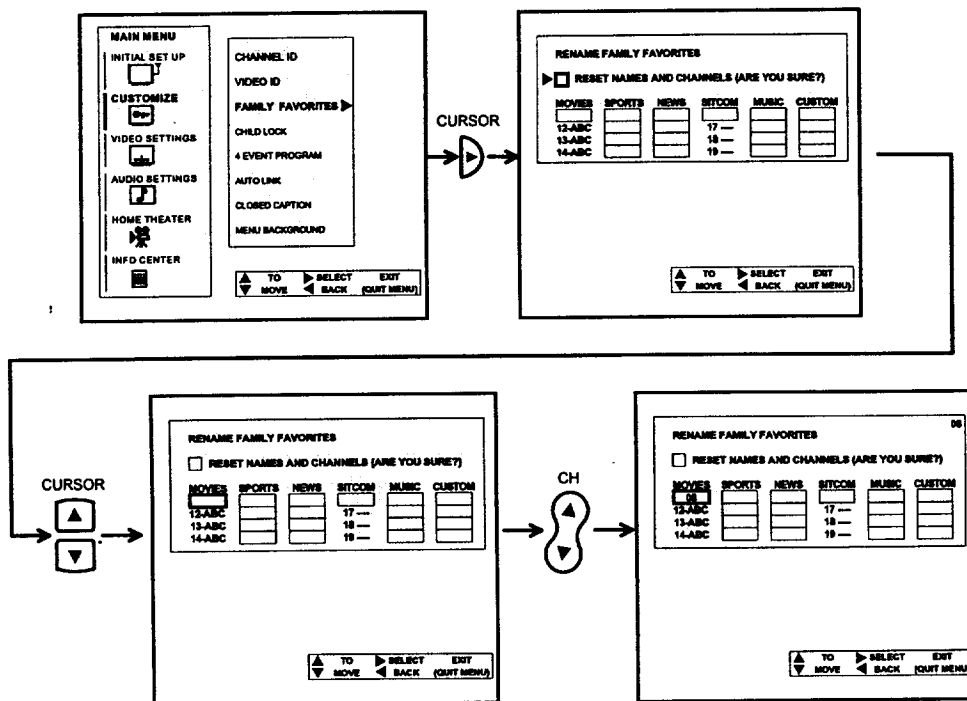

To rename the categories, use CURSOR buttons to highlight the category you would like to rename. Use CURSOR ▲ or ▼ to change a letter and CURSOR ► to select the next character to change.

To reset categories and channels back to original factory preset, select RESET then press CURSOR ►.

To enter a channel into a category, highlight a box below the category title.

Press CHANNEL ▲ or ▼ or the number buttons to enter the desired channel. Repeat until category has been set with your favorite channels. The channel to be added is displayed in the top right corner of the screen.

Enter channel 00 to erase a favorite channel.

NOTE: This function cannot be accessed when ANT B is the main channel.



CUSTOMIZE

FAMILY FAVORITES (OPERATION)

Use this function to display FAMILY FAVORITES selections as sub-pictures or to tune the main picture to a desired favorite channel.

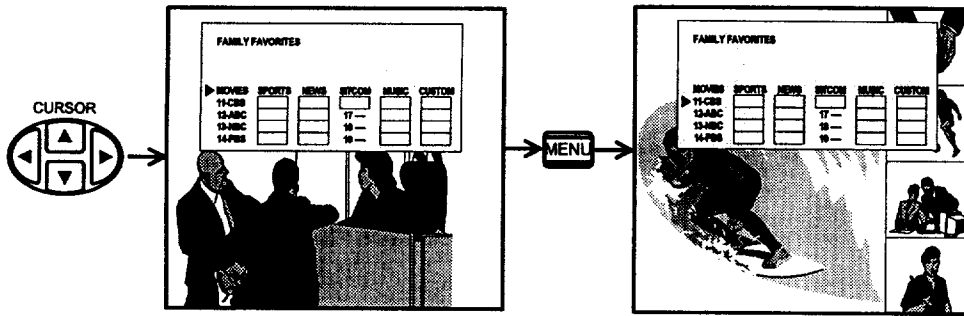

Press any CURSOR button.

Select a category heading using CURSOR ◀ or ▶.

Press MENU and the category will be displayed as sub-pictures at the right edge of the screen. This is useful for previewing a category.

Use the CURSOR buttons to highlight a favorite channel and the TV will automatically tune to that channel.

Press EXIT to remove FAMILY FAVORITES OSD from the screen.

NOTE: If a category has some blank channel entries, these channels will appear as black sub-pictures.

CUSTOMIZE



CHILD LOCK

This function will block out the picture and sound of the selected channel or video input. It can also be used to keep the TV from being viewed for a scheduled amount of time that you set.

The code to enter CHILD LOCK is a four digit key number. The factory preset code is 0000. Use CURSOR ▲ or ▼ or the number keys to select number and CURSOR ► to change position.

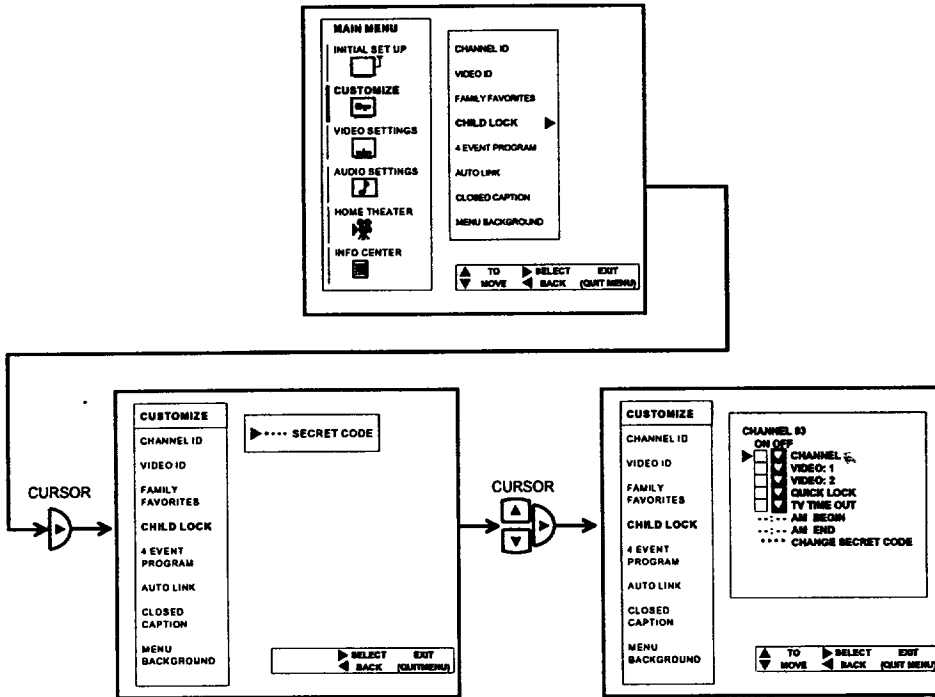

Use CURSOR ▲ or ▼ to highlight function and CURSOR ► to set ON or OFF.

When CHANNEL is turned on, the picture and sound for the chosen channel will be blocked out.

When VIDEO: 1 or 2 is turned on, the picture and sound for the chosen video input will be blocked out (To lock a Video input, you must be tuned to the input you wish to lock).

When QUICK LOCK is turned on, the picture and sound for channels 3, 4 and all Video inputs will be blocked out.

When TV TIME OUT is turned on, you can set the BEGIN and END times and the TV cannot be viewed during that time period.

To change the key number, select CHANGE SECRET CODE. Enter a new four digit key number you prefer.

If you forget your key number, use the factory code 7777 to erase your key number. This will reset the key number back to the factory preset 0000.

NOTE: If ANT A and ANT B are in the same SIGNAL SOURCE mode (see page 29), when a channel is locked, it is locked on both antenna inputs.
 — When using TV TIME OUT make sure the clock is set (see page 33).



CUSTOMIZE

4 EVENT PROG.

This function will automatically turn the TV on and off, one time only, every day or once a week.

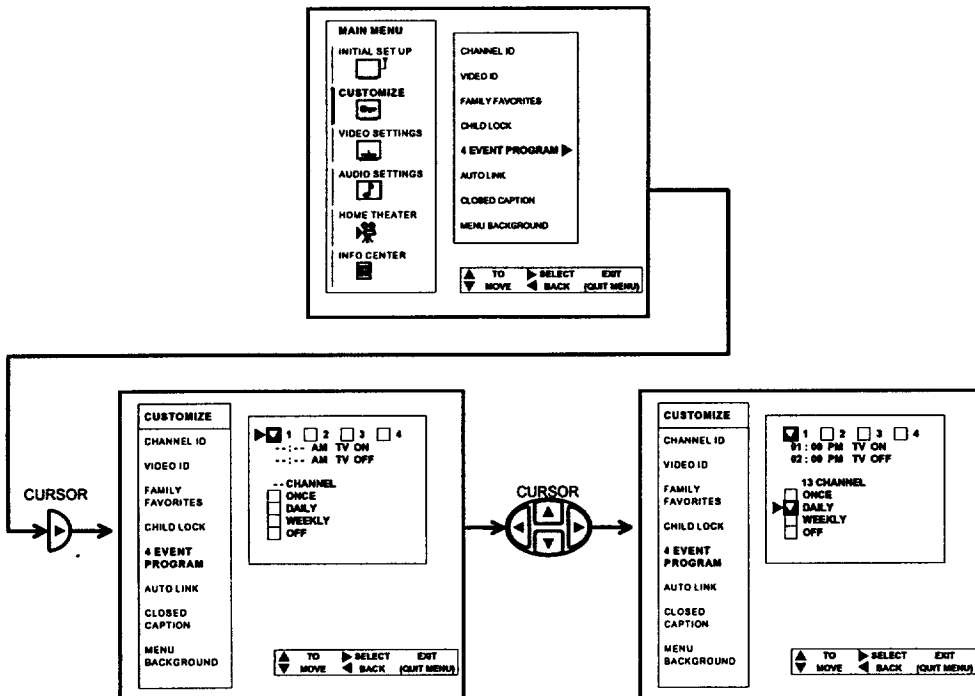

Press CURSOR ► to select PROGRAM 1, 2, 3 or 4.
 Press CURSOR ▲ or ▼ to select the time the TV will turn on and off.
 Use CURSOR ► to change position.
 Press CURSOR ▲ or ▼ to highlight then CURSOR ► to select MODE: ONCE (one time only) or MODE: DAILY (TV will turn on/off at the same time every day), or MODE: WEEKLY (TV will turn on/off at same time every week).
 Press CURSOR ▲ or ▼, CHANNEL ▲ or ▼, or number buttons to set the channel the TV will tune to when it automatically turns on.

NOTE: The OFF Timer will only activate if the TV was turned on or tuned with the ON timer and no channel selection was made after this time. If you change the channel after the ON Timer has been activated, the OFF Timer will deactivate.
 If no remote control button is pressed after ON timer is activated, the TV will automatically turn off after 3 hours.

CAUTION: Do not use your TV as a deterrent when away from home by using the ON and OFF TIMERS. For safety, the TV should be turned off when you are away from home.

CUSTOMIZE



AUTO LINK

Use this function to automatically turn the TV on and tune to VIDEO: 1, when it detects a VIDEO: 1 input.

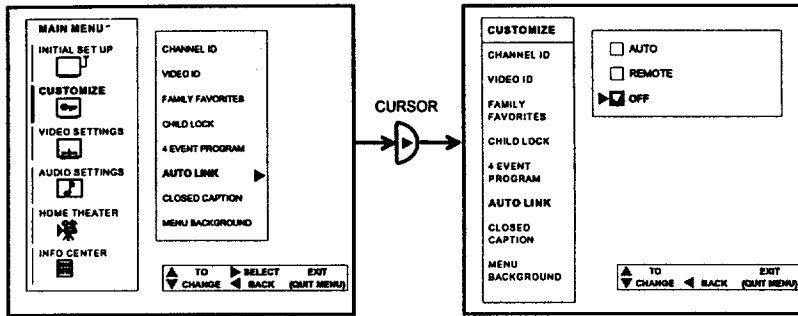

Use CURSOR ▲ or ▼ to change AUTO LINK setting.

When AUTO is selected, the TV will turn on and tune to VIDEO: 1 automatically, when a VIDEO: 1 input is detected. This is convenient when you want to watch a movie with your VCR or Laser Disc Player.

When REMOTE is selected, the TV will turn on and tune to VIDEO: 1 automatically, when a VIDEO: 1 input is detected and the VCR play button on your remote control is pressed. This is convenient when you want to record a movie with your VCR and watch it later.

Select OFF to disable this function.
Press EXIT to quit menu or CURSOR ◀ to return to previous menu.



CUSTOMIZE

CLOSED CAPTION

Closed captions are the dialogue, narration, and/or sound effects of a television program or home video which are displayed on the TV screen. Your local TV program guide denotes these programs as or .

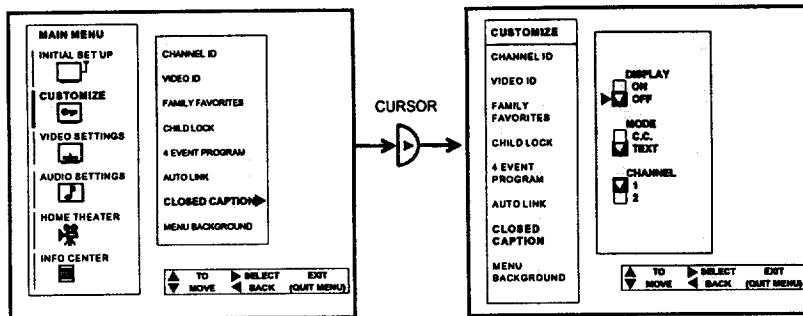

DISPLAY: ON/OFF will turn the display on or off.

MODE: C.C. (Closed Caption) is for the program you are viewing.

MODE: TEXT is for additional information such as news reports or a TV program guide. This information covers the entire screen and viewing the TV program is not possible. TEXT may not be available with every program.

CHANNEL: 1 is used for the primary language (usually English).

CHANNEL: 2 is sometimes used for a second language (may vary by region).

Use CURSOR ▲ or ▼ to highlight the function to change; press CURSOR ► to change the function. Press EXIT to quit menu or CURSOR ◀ to return to previous menu.

NOTE: If you do not have sound, make sure MUTE is not set. CCD will display when "MUTE" is pressed, whether CCD is in the "ON" or "OFF" mode.

CUSTOMIZE



MENU BACKGROUND This function allows you to choose from 2 MENU BACKGROUNDS.

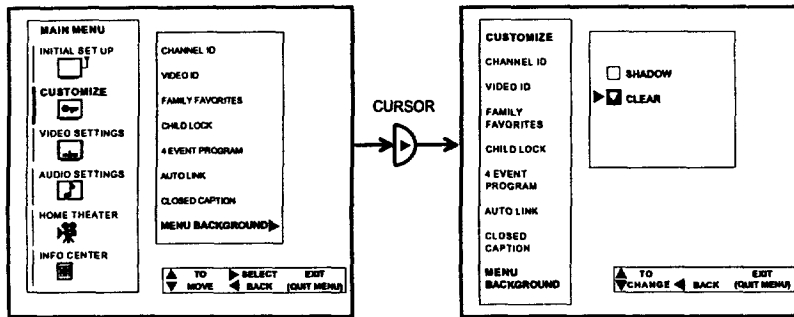

Use CURSOR ▲ or ▼ to change MENU BACKGROUND setting.
Select SHADOW and a light background is visible. Select CLEAR and no background is visible.
Press EXIT to quit menu or CURSOR ◀ to return to previous menu.



VIDEO SETTINGS

VIDEO SETTINGS

Select VIDEO SETTINGS to adjust picture settings and improve picture quality.

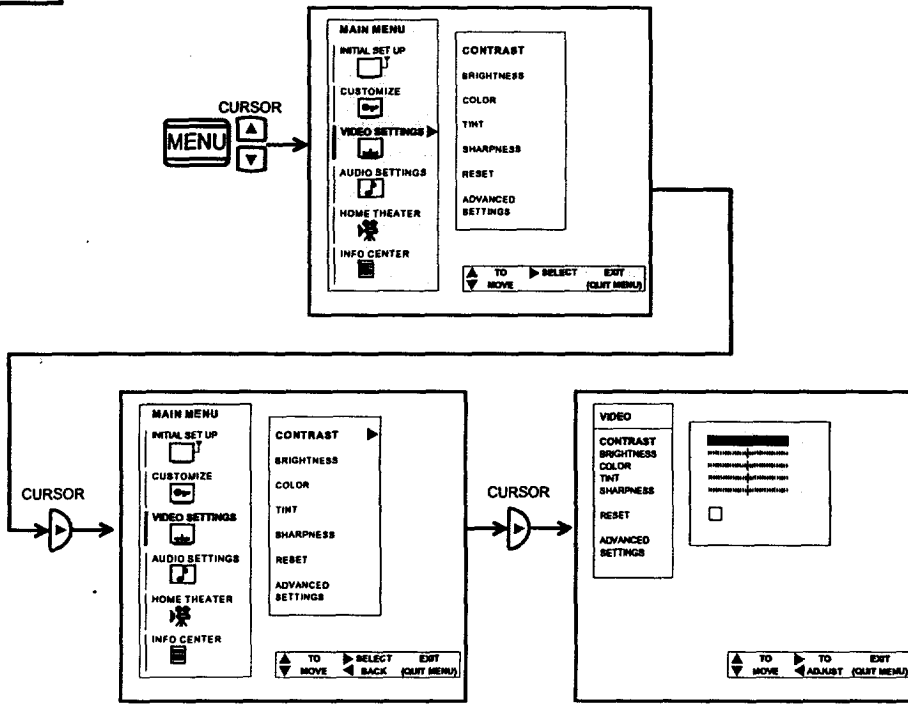

Use the CURSOR ▲ or ▼ to highlight the function to be adjusted.

Press CURSOR ◀ or ▶ to adjust the function.

Use CURSOR ▲ or ▼ to highlight RESET or ADVANCED SETTINGS, then CURSOR ◀ to return to previous menu. Press EXIT to quit menu.

NOTE: If CONTRAST is selected, you are adjusting CONTRAST. The additional menu items BRIGHTNESS, COLOR, TINT, and SHARPNESS can be selected and adjusted in the same manner.

CONTRAST

Use this function to change the contrast between black and white levels in the picture. This adjustment will only affect the picture when PICTURE SETTINGS AI is OFF. (See page 45.)

BRIGHTNESS

Use this function to adjust overall picture brightness.

COLOR

Use this function to adjust the level of color in the picture.

TINT

Use this function to adjust flesh tones so they appear natural.

SHARPNESS

Use this function to adjust the amount of fine detail in the picture.

—RESET

When RESET is selected, press CURSOR ▶ to return video adjustments to factory preset conditions.

VIDEO SETTINGS



ADVANCED SETTINGS

Your HITACHI TV has an AI (Artificial Intelligence) function which will automatically adjust picture settings to produce the highest quality picture possible. When AI is highlighted, use CURSOR ► to turn the AI on or off.

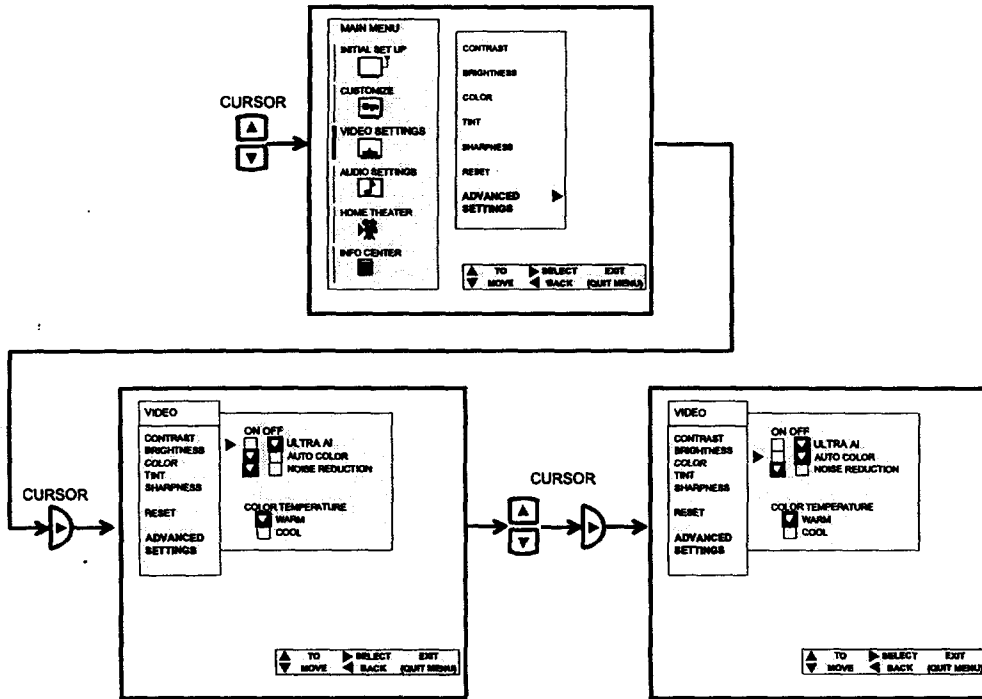

Use CURSOR ▲ or ▼ to select function.
Use CURSOR ► to change the function setting.
Press EXIT to quit menu or CURSOR ◀ to return to previous menu.

AI (ARTIFICIAL INTELLIGENCE)

When the AI function is on, the TV's internal computer will perform the following:

1. Automatically monitor and adjust contrast depending on room lighting (sensor is located in the front panel) to produce a more natural picture.
2. Automatically monitor and adjust color levels and maintain natural flesh tones.
3. Automatically compensate for weak or strong TV signals to produce a clear picture.

Turn the AI function off to control other PREFERENCE SETTINGS.

AUTO COLOR

The AUTO COLOR function automatically monitors and adjusts the color to maintain constant color levels even after a program or channel changes. It also maintains natural flesh tones while preserving fidelity of background colors. For best picture performance leave the AUTO COLOR function on.

NOISE REDUCTION

The NOISE REDUCTION function automatically reduces conspicuous noise in the picture without degrading picture quality.

COLOR TEMPERATURE

Set this to WARM for hotter colors with more red, or set to COOL for less intense colors with more blue.



AUDIO SETTINGS



Select AUDIO SETTINGS to adjust the TV to your preference and to improve the sound quality.

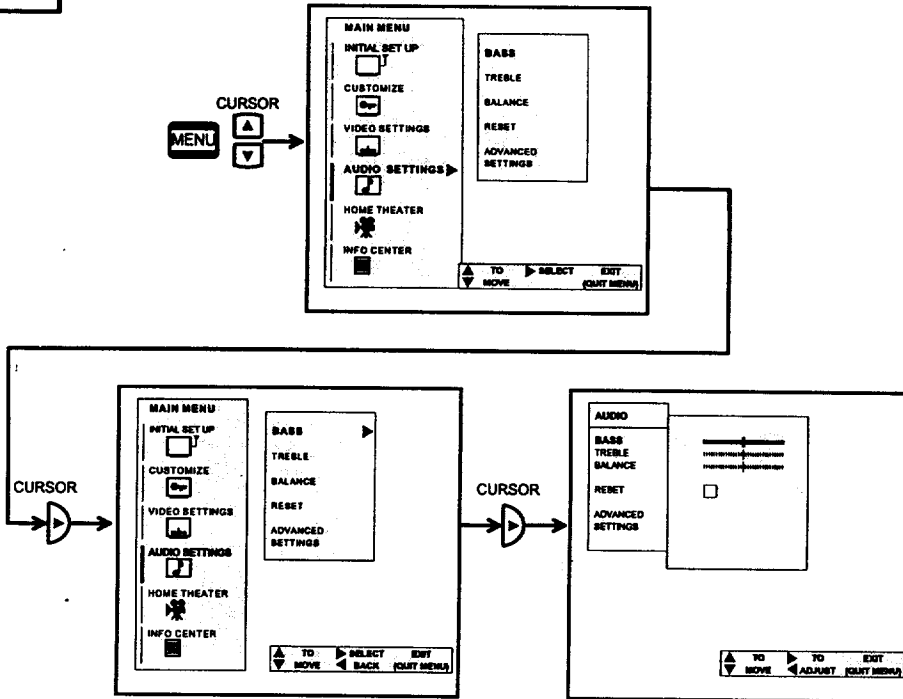

Use CURSOR ▲ or ▼ to highlight the function to be adjusted.
 Press CURSOR ◀ or ▶ to adjust the function.
 Use CURSOR ▲ or ▼ to highlight RESET or ADVANCED SETTINGS, then CURSOR ◀ to return to previous menu.
 Press EXIT to quit menu.

NOTE: If BASS is selected you are adjusting BASS. The additional menu items TREBLE and BALANCE can be selected and adjusted in the same manner.

BASS

This function controls the low frequency audio to all speakers.

TREBLE

This function controls the high frequency audio to all speakers.

BALANCE

This function will control the left to right balance of the TV internal speakers, the AUDIO TO HI FI output, the TRANSMITTER OUT output, and the Surround Speakers.

RESET

When RESET is selected, press CURSOR ▶ to return audio adjustments to factory preset conditions.

AUDIO SETTINGS



ADVANCED SETTINGS

Use **ADVANCED SETTINGS** to improve the sound performance of your TV depending on listening conditions.

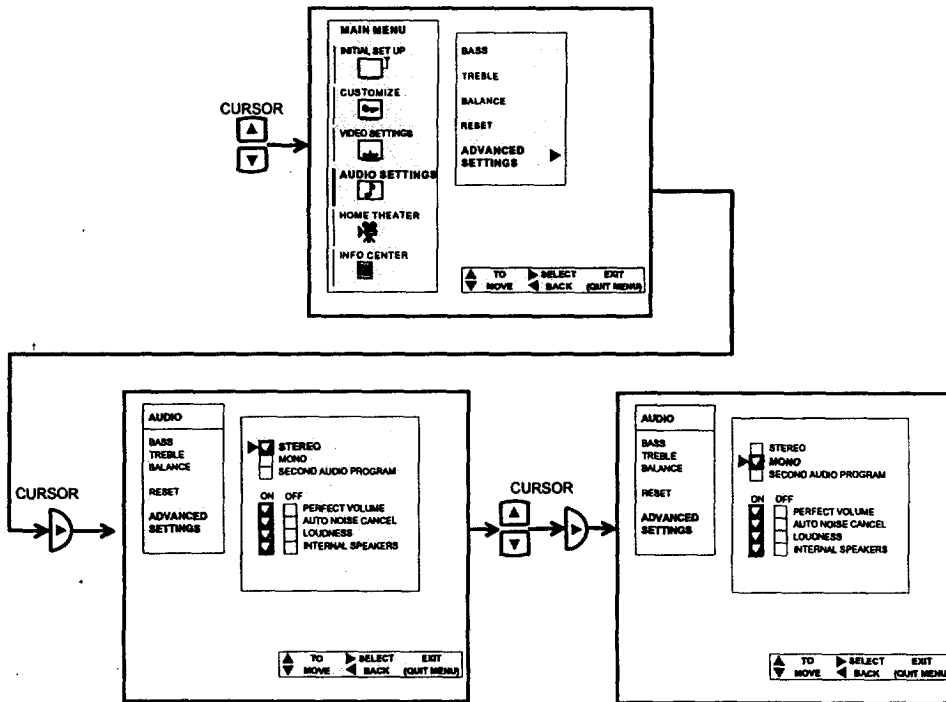

Press **CURSOR** ▲ or ▼ to highlight a function.
 Press **CURSOR** ► to change the function setting.
 Press **EXIT** to quit menu or **CURSOR** ◀ to return to previous menu.

MTS MODE

(Multi-Channel Television Sound) will allow you to select **STEREO** (a stereo broadcast), **SAP** (second audio program) which may be a secondary language, weather report, etc. or **MONO** (monaural sound) used when receiving a weak stereo broadcast.

The sources received will be displayed below the channel number. The source you select will be displayed to the left of the channel number. See example below for each selection when both stereo and second audio are received (monaural is always received).

STEREO SELECTED



SAP SELECTED



MONO SELECTED



PERFECT VOLUME

This function will automatically adjust volume so each channel has the same average volume level.

AUTO NOISE CANCEL

This function eliminates the noise in between stations. If a channel is tuned and is noisy, this function will automatically eliminate the audio for that channel.

LOUDNESS

This function will improve the quality of both low and high frequency sounds when listening at low volume levels.

INT. SPEAKERS

This function is useful when first setting up the external speakers, or if you prefer to use only speakers from a separate stereo system.



HOME THEATER

HOME THEATER



Use this function to choose Picture settings for a true HOME THEATER experience.

THEATER MODES

Use this function to choose from automatic picture settings to optimize your TV's performance.

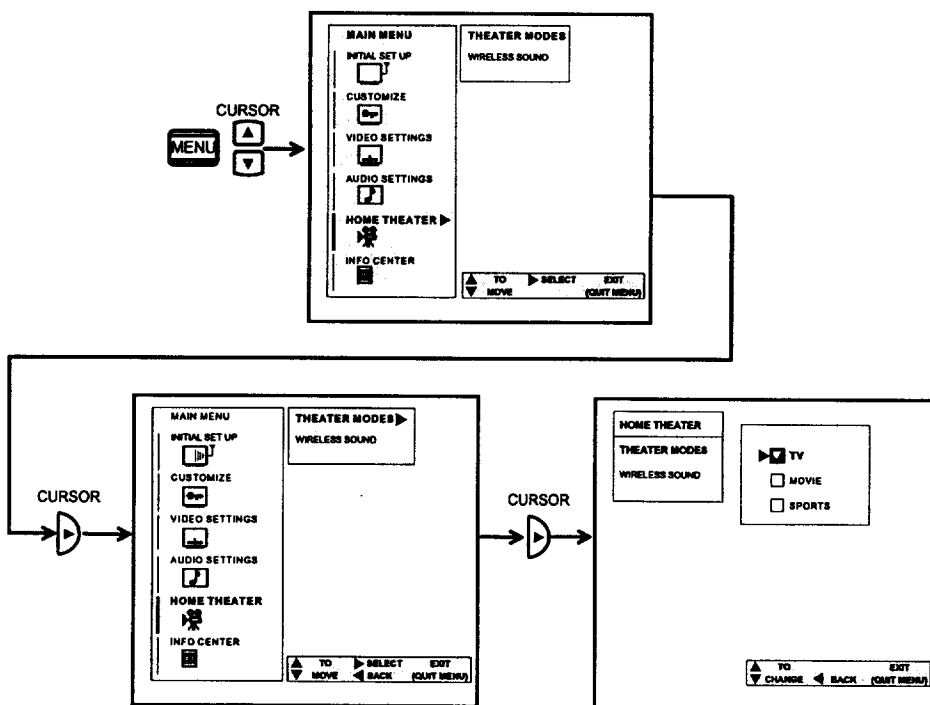

Use CURSOR ▲ or ▼ or the HOME THEATER button on your remote control to change THEATER MODES settings. Select TV mode to set AI to your preference.

When MOVIE mode is chosen, AI is automatically set to ON.

When SPORTS mode is chosen, AI is automatically set to ON. (AI is automatically made brighter by increasing Contrast, to improve Sports viewing.)

Press EXIT to quit menu or CURSOR ◀ to return to previous menu.

HOME THEATER



WIRELESS SOUND

This feature allows you to choose between 2 possible variable audio outputs for a separate set of wireless speakers or another stereo amplifier. The audio output may be either MAIN TV AUDIO or SUB PICTURE AUDIO.

This feature also allows you to turn the internal speakers on or off, when MAIN TV AUDIO is chosen. You can also adjust PIP volume if you have chosen SUB PICTURE AUDIO as your variable audio output.

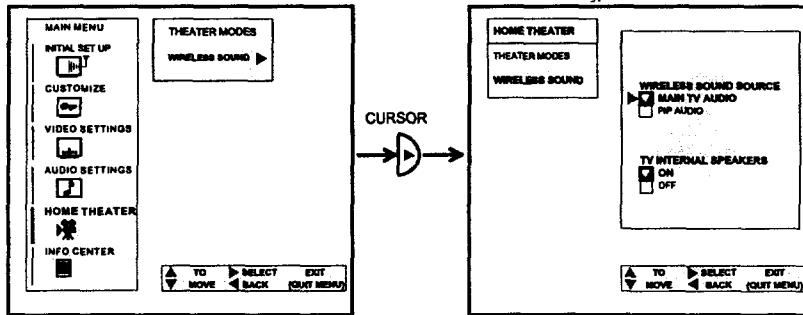

Press CURSOR ▲ or ▼ to highlight a function.

Press CURSOR ► to select the function.

Press EXIT to quit menu or CURSOR ◀ to return to previous menu.

MAIN TV AUDIO

When set to MAIN TV AUDIO mode, your wireless speakers will play the same audio program as played on your TV. When set to this mode, you may choose to turn the television's internal speakers on or off. Also, the volume of your wireless speakers will be controlled by the TV volume control.

SUB PICTURE AUDIO

When set to SUB PICTURE AUDIO mode, your wireless speakers will play the PIP sub-picture audio program. The volume of your wireless speakers will now be controlled by the PIP VOL. control, which may be varied from 00 (min.) to 32 (max.). If no sub-picture is displayed, the wireless speakers will play the main channel audio program with the volume being controlled by the TV volume control.



INFO CENTER

INFO. CENTER

This function allows your TV to assist you with your busy day to day schedule.

SPECIAL EVENT REMINDER

Use this function to set up to 6 special events into memory. These events can then be viewed in CALENDAR mode.

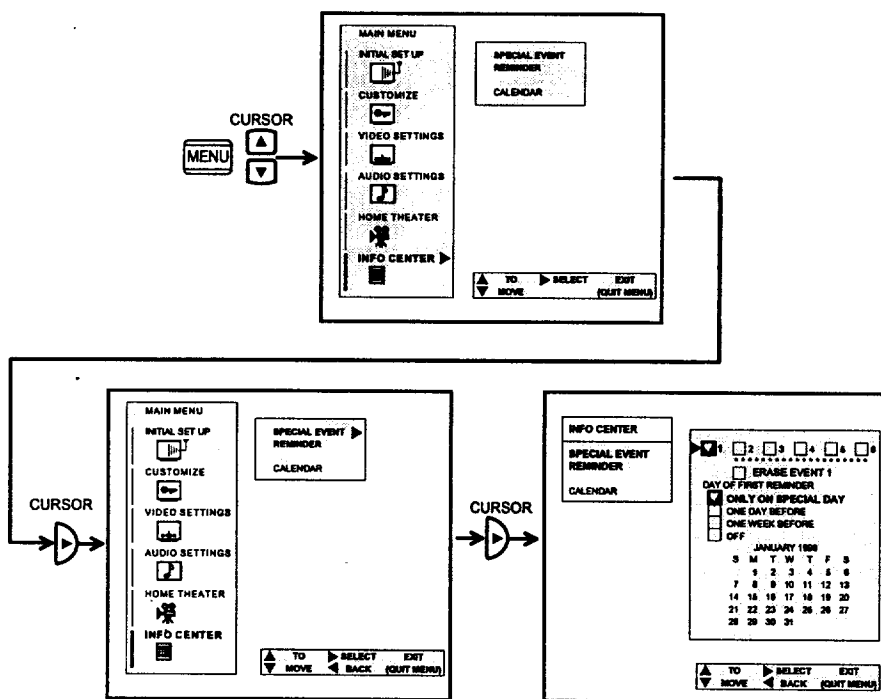

Press CURSOR ► to select EVENT 1 to 6.
 Press CURSOR ▲ or ▼ to select a letter.
 Press CURSOR ► to change position.

To erase Special Event, select ERASE EVENT then press CURSOR ►.
 Highlight the day of first reminder using CURSOR buttons, then press CURSOR ► to select.
 Select date of reminder using CURSOR buttons.

To exit date set mode but remain in SPECIAL EVENT REMINDER menu, press the MENU button.
 Press EXIT to quit menu or CURSOR ◀ to return to previous menu.

NOTE: Special events set into memory will appear as blinking green dates in CALENDAR mode. At the selected time, the message will appear in CALENDAR mode.
 When the TV is turned on, the SPECIAL EVENT REMINDER message will automatically appear at the selected time.
 Each special event message can be a maximum of 20 characters long.

INFO CENTER



CALENDAR

Use this function to check the day, month, and year.

Dates programmed in SPECIAL EVENT REMINDER will appear blinking and special event message will be displayed.

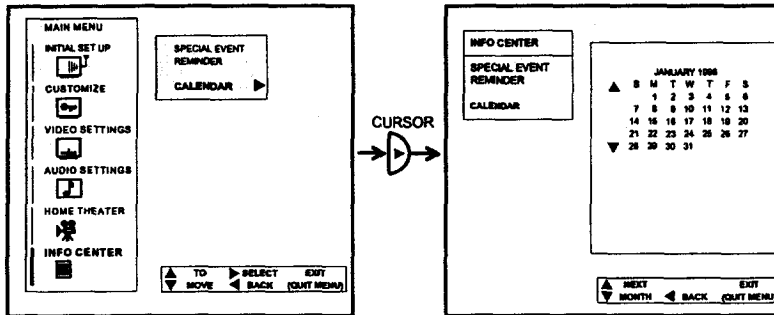

Press CURSOR ▲ or ▼ to change the month.

Press EXIT to quit menu or CURSOR ◀ to return to previous menu.

NOTE: Dates of SPECIAL EVENT REMINDER will appear blinking. Special event message will be displayed only if current date is within the Day Of First Reminder Specifications as chosen in SPECIAL EVENT REMINDER. (See page 50.)
CALENDAR will appear blinking when a Special Event message is set.



CARE OF YOUR HITACHI PROJECTION TV AND YOUR REMOTE CONTROL

DO

Dust the screen and cabinet with a soft cloth.

Clean the screen with a soft cloth moistened in warm water. Dry with a soft cloth (A mild soap may be used if the screen is extremely dirty).

Place your TV and remote control away from extreme heat, humidity and extremely dusty places.

Remove the plug from the wall outlet if your television will not be used for a long period of time, for instance, when you go on vacation.

DO NOT

Do not clean your screen or cabinet with strong cleaners, polishes, or chemically treated cloth.

Do not place rubber or vinyl products or cellophane tape on your set.

Do not touch the screen too often.

Do not subject the remote control to shocks such as dropping it on the floor, etc. Physical damage to the precision parts may result.





Avoid placing the remote control in a high humidity place or getting it wet. Don't leave it on or near a heater. Excessive heat or moisture may cause the unit to cease operation.

When the batteries run down, remote control operation will become erratic or possibly stop altogether. Replace the old batteries with two fresh "AA" size batteries.

Exposure of the viewing screen to prolonged direct sunlight or heat may cause the screen to permanently warp, resulting in a distorted picture.

RECEPTION PROBLEMS



	<ul style="list-style-type: none">• IGNITION NOISE: Black spots or horizontal streaks may appear, picture may flutter or drift. Usually caused by interference from automobile ignition systems, neon lamps, electrical drills, and other electrical appliances.
	<ul style="list-style-type: none">• GHOSTS: Ghosts are caused by the television signal following two paths. One is the direct path and the other is reflected from tall buildings, hills or some other objects. Changing the direction or position of the antenna may improve reception. Ghosting may also be caused by defects in the antenna system such as unshielded leads or connecting several sets to the same antenna without using multiple antenna couplers.
	<ul style="list-style-type: none">• SNOW: If your receiver is located in the fringe area of a television station where the signal is weak, your picture may be marred by the appearance of small dots. When the signal is extremely weak, it may be necessary to install a special antenna to improve the picture.
	<ul style="list-style-type: none">• RADIO FREQUENCY INTERFERENCE The interference produces moving ripples or diagonal streaks, and in some cases, causes loss of contrast in the picture.



CHECK HERE BEFORE CALLING FOR SERVICE

SYMPTOMS	CHECK THESE ITEMS AND TRY THESE ADJUSTMENTS											
	Be sure external connector is correct	Be sure power cord is plugged in	Be sure TV is switched "ON"	Try another channel (station trouble)	Check antenna connections (back of TV)	Check antenna for broken lead-in wire	Check for local interference	Adjust Contrast control	Adjust Brightness control	Adjust Color control	Adjust Tint control	Adjust Volume control
No Picture, no sound	●	●	●	●	●	●						
Sound OK, picture poor	●			●	●	●	●	●				
Picture OK, sound poor	●			●	●	●	●					●
Picture blurred	●			●	●	●	●					
Lines or streaks in picture				●	●	●	●					
Poor reception on some channels				●	●	●	●					
Picture rolls vertically				●			●					
No color	●			●	●	●	●			●		
Poor color	●			●	●	●	●			●	●	

This Projection Television incorporates advanced power surge protection technology designed to protect against component or circuit damage due to internal voltage or power surges.

IF YOUR SET SHOULD APPEAR TO HAVE A LOSS OF POWER, PLEASE FOLLOW THIS PROCEDURE:

- 1) Push the power switch (ON/OFF switch) once.
- 2) If there is still no power, wait 30 seconds and push the power switch again.
- 3) If there is still no power, unplug the power cord from the wall. Wait thirty seconds and plug the power cord back in. Push the power switch again.

This protective technology should provide for years of lasting entertainment from your Projection Television.

SPECIFICATIONS



Features:

- Superfine Picture Quality
 - 800 Line Horizontal Resolution
- Pure Green and Red Filter Lenses
- Artificial Intelligence System
- Remote (Controls many VCR brands and Cable/Satellite equipment)
- High Definition On-Screen Display (UltraTEC)
- Full set of Input Jacks, including S-Video
- Closed Caption Decoder
- High Resolution Picture-In-Picture with Freeze
- Tuned Port Bass Reflex Speakers
- Digital Convergence
- Dual Antenna Inputs
- Auto Link

Inputs:

- Power InputAC 120V, 60Hz
- Power Consumption (operating)
 - 50FX18B/19K163W
 - 55FX20B163W
- Power Consumption (Maximum)
 - 50FX18B/19K216W
 - 55FX20B216W
- Antenna input impedance75 Ohm
- Channel coverage181 ch.
 - VHF-Band2 ~ 13
 - UHF-Band14 ~ 69
 - CATV Mid BandA-5 ~ A-1
 -A-1
 - Super BandJ-W
 - Hyper BandW+1 - W+28
 - Ultra BandW+29 - W+84
- Video1.0Vp-p, 75 Ohm
- S-Video
- Luminance (Y)1.0Vp-p, 75 Ohm
- Chrominance (C)0.286Vp-p, 75 Ohm
- Audio input level47k Ohm
- Average input level470mVrms
- Maximum input level940mVrms

Outputs:

- Video1.0Vp-p, 75Ohm
- Audio (fixed)470mVrms, 1k Ohm

Dimensions:

	50FX18B/19K	55FX20B
• Height (in.)	51 ¹³ / ₁₆	54 ⁹ / ₁₆
• Width (in.)	43 ³ / ₁₆	47 ¹ / ₈
• Depth (in.)	23 ¹ / ₈	26 ⁹ / ₁₆
• Weight (lbs.)	230	267

NOTE: Due to improvements, specifications in this operating guide are subject to change without notice.



HITACHI

*Service
hotline*

To locate an authorized
HITACHI service facility
in the continental
U.S.A. and Canada,

DIAL TOLL FREE

7 days a week, 24 hours a day

800 HITACHI

1-800-448-2244

Hitachi Home Electronics (America), Inc.

Hitachi has made every effort to assure you hours of trouble free operation from your unit. However, should you require service, a network of Hitachi Authorized Service Facilities has been established in all 50 states and Puerto Rico. Each facility will provide you with convenient and expedient assistance. Our service "Hotline" operator will direct you to the Hitachi Authorized Service Facility nearest you. Just present proof of purchase and/or delivery receipts to the Hitachi Authorized Service Facility, and service will be rendered in accordance with the terms of the limited warranty as stated on your warranty card or operating guide.

Should you have any questions regarding in-warranty service, operation or technical assistance, please contact:

Hitachi Home Electronics (America), Inc.
3890 Steve Reynolds Blvd.
Norcross, GA 30093
Tel: 770-279-5600

Hitachi Sales Corporation of Hawaii
3219 Koapaka St.
Honolulu, HI 96819
Tel: 808-839-3621

For TV's purchased in Canada only, please contact one of the Hitachi offices below, should you have any questions regarding service, operation or technical assistance.

MONTREAL
9425 Trans Canada
Saint-Laurent, Quebec
H4S 1V3

TORONTO
6740 Campobello Road
Mississauga, Ontario
L5N 2L8

VANCOUVER
54 Humber Place, Annacia Industrial Estate
New Westminster, B.C.
V3M 6A6

Tel: (514) 956-9882
Fax: (514) 956-9761

Tel: (905) 821-4545
Fax: (905) 826-6627

Tel: (604) 526-8566
Fx: (604) 526-8127

USEFUL INFO



Accessories	6	Mono Sound	12, 47
AI (Artificial Intelligence)	9, 45	Move	21
Antenna	7, 8, 10, 16	Mute	15, 17, 42
Audio to Hi-Fi	10	PIP (Picture-in-Picture)	15, 19
Audio Settings		PIP CH Button	15, 16, 19
Advanced Settings	47	Phono Connector	8
Bass	46	Picture Cautions	5
Balance	46	Power	
Reset	46	Light	9
Treble	46	Button	9, 15
Audio System Setup	11, 13	Quick List	16
Battery Replacement	6, 52	Rear Speaker Connections	10, 12, 13
Cable Box Codes	23, 24	Recall	15
Cable Button	15, 17, 23, 24	Reception	
Cables, Hook up	8	Band	29
Care for your TV and Remote	52	Problems	53
CATV	4, 8, 29	Remote Control	
Channel	9, 16	Cable Box Functions	23
Commercial Skip	15	Sensor	9, 14
Connections		TV Functions	15
Antenna	4, 8	VCR Functions	22
Rear Panel	11	Reset	44, 46
Cursor	9, 15, 16, 25	S-Video	8, 10, 12
Customize		Safety Tips	2, 3, 4
Auto Link	41	SA, SAP	15, 47
Channel ID	35	Service Hotline	56
Child Lock	39	Service	4, 56
Closed Caption	42	Sleep	15, 18
Family Favorites	37, 38	Specifications	55
4 Event Program	40	Surround Switch	10
Menu Background	43	Swap	21
Video ID	36	Twin Lead Connector	8
Dual Tuner	10, 19	UHF/VHF	8, 29
Exit Button	9, 15, 25	UltraTEC OSD	25
F-Connector	8	VCR Codes	22, 24
Freeze	21	Video Settings	
Front Panel Controls	9	Advanced Settings	45
Home Theater		Brightness	44
Theater Modes	48	Color	44
Wireless Sound	49	Contrast	44
Important Safeguards	2, 3, 4	Reset	44
Info Center		Sharpness	44
Calendar	51	Tint	44
Special Event Reminder	50	Volume	9, 15, 17
Initial Setup			
Auto Channel Set	30		
Channel List	32		
Channel Memory	31		
Clock Set	33		
Convergence Adjust	34		
Menu Language	27		
Plug & Play	28		
Signal Source	29		
Input Button	9, 10, 16, 19		
Jacks			
Rear panel	10		
Light Button	14		
Location, Viewing	3, 7, 52		
LST-CH	15, 17		
Menu	9, 15, 16, 25		



NOTES



HITACHI