

Color Rear Video Projector

Operating Instructions _____

EN

Manual de instrucciones _____

ES

***KP-41T65
KP-48S65
KP-53S65
KP-61S65***

WARNING

To prevent fire or shock hazard, do not expose the unit to rain or moisture.

CAUTION
RISK OF ELECTRIC SHOCK
DO NOT OPEN

ATTENTION
RISQUE DE CHOC ELECTRIQUE,
NE PAS OUVRIR



PRECAUCION
RIESGO DE CHOQUE ELECTRICO
NO ABRIR



CAUTION : TO REDUCE THE RISK OF ELECTRIC SHOCK,

- DO NOT REMOVE COVER (OR BACK).

NO USER-SERVICEABLE PARTS INSIDE.

REFER SERVICING TO QUALIFIED SERVICE PERSONNEL.



This symbol is intended to alert the user to the presence of uninsulated "dangerous voltage" within the product's enclosure that may be of sufficient magnitude to constitute a risk of electric shock to persons.



This symbol is intended to alert the user to the presence of important operating and maintenance (servicing) instructions in the literature accompanying the appliance.

CAUTION

To prevent electric shock, do not use this polarized AC plug with an extension cord, receptacle or other outlet unless the blades can be fully inserted to prevent blade exposure.

CAUTION

When using TV games, computers, and similar products with your projection TV, keep the brightness and contrast functions at low settings. If a fixed (non-moving) pattern is left on the screen for long periods of time at a high brightness or contrast setting, the image can be permanently imprinted onto the screen. These types of imprints are not covered by your warranty because they are the result of misuse.

Note on Caption Vision

This television receiver provides display of television closed captioning in accordance with §15.119 of the FCC rules.

2-EN

Note on CATV system installer

This reminder is provided to call the CATV system installer's attention to Article 820-40 of the NEC that provides guidelines for proper grounding and, in particular, specifies that the cable ground shall be connected to the grounding system of the building, as close to the point of cable entry as practical.

Use of this television receiver for other than private viewing of programs broadcast on UHF or VHF or transmitted by cable companies for the use of the general public may require authorization from the broadcaster, cable company and/or program owner.

Note on convergence adjustment

Before you use your projection TV, make sure to adjust convergence. For the procedure, see page 14.

NOTIFICATION

This equipment has been tested and found to comply with the limits for a Class B digital device pursuant to Part 15 of the FCC Rules. These limits are designed to provide reasonable protection against harmful interference in a residential installation. This equipment generates, uses, and can radiate radio frequency energy and, if not installed and used in accordance with the instructions, may cause harmful interference with radio communications. However, there is no guarantee that interference will not occur in a particular installation. If this equipment does cause harmful interference to radio or television reception, which can be determined by turning the equipment off and on, the user is encouraged to try to correct the interference by one or more of the following measures:

- Reorient or relocate the receiving antennas
- Increase the separation between the equipment and receiver.
- Connect the equipment into an outlet on a circuit different from that to which the receiver is connected.
- Consult the dealer or an experienced radio/TV technician for help.

You are cautioned that any changes or modifications not expressly approved in this manual could void your authority to operate this equipment.

This document is for the remote control RM-Y136A.
MODELS: KP-41T65/48S65/53S65/61S65.

Please keep this notice with the instruction manual.



As an ENERGY STAR Partner, Sony Corporation has determined that this product meets the ENERGY STAR guidelines for energy efficiency.

Owner's Record

The model and serial numbers are located at the rear of the projection TV. Record these numbers in the spaces provided below. Refer to them whenever you call upon your Sony dealer regarding this product.

Model No. _____

Serial No. _____

Table of contents

- 4 Welcome!
- 4 Precautions

Getting Started

- 5 Step 1: Installing the projection TV
- 6 Step 2: Hookup
- 13 Step 3: Setting up the remote control
- 14 Step 4: Setting up the projection TV automatically (AUTO SET UP)
- 18 Changing the menu language

Operations

- 19 Watching the TV
- 21 Watching two programs at one time—PIP
- 22 Freezing the picture (FREEZE)
- 23 Adjusting the picture (VIDEO)
- 24 Adjusting the color temperature (TRINITONE)
- 24 Selecting the video mode (VIDEO)
- 25 Adjusting the sound (AUDIO)
- 26 Using audio effect (SURROUND)
- 27 Selecting stereo or bilingual programs (MTS)
- 27 Setting the speaker switch (SPEAKER)
- 28 Setting audio out (AUDIO OUT)
- 29 Setting daylight saving time (DAYLIGHT SAVING)
- 29 Setting the clock (CURRENT TIME SET)
- 30 Setting the timer to turn the projection TV on and off (ON/OFF TIMER)
- 31 Customizing the channel names (CHANNEL CAPTION)
- 32 Blocking out a channel (CHANNEL BLOCK)
- 32 Setting your favorite channels (FAVORITE CHANNEL)
- 33 Setting video labels (VIDEO LABEL)
- 34 Setting Caption Vision (CAPTION VISION)
- 35 Operating video equipment
- 37 Operating a cable box or DBS receiver

EN

Additional Information

- 38 Troubleshooting
- 39 Specifications
- 40 Index to parts and controls

- 42 **Index**

The captions in parentheses indicate menu names.

Welcome!

Thank you for purchasing the Sony Color Rear Video Projection TV. Here are some of the features you will enjoy with your projection TV:

- On-screen menus that let you set the picture quality, sound, and other settings.
- Two tuner Picture-in-Picture (PIP) that allows you to watch another TV channel, video or cable image as a window picture.
- Surround mode that simulates the sound quality of a concert hall or movie theater.
- SAVA SPEAKER option of the AUDIO menu that lets you take advantage of the Sony SAVA series speaker system's surround sound and super woofer mode when you connect it to the projection TV.

About this manual

The instructions in this manual are for models KP-41T65, KP-48S65, KP-53S65, and KP-61S65. Before you start reading this manual, please check your model number, located at the rear of the projection TV.

Model KP-53S65 is used for illustration purposes in this manual. Any differences in operation are clearly indicated in the text, for example "*KP-61S65 only.*"

The differences in specifications are indicated in the text.

Instructions in this manual are based on use of the remote control. You can also use the controls on the projection TV if they have the same name as those on the remote control.

Precautions

This projection TV operates on extremely high voltage. To prevent fire or electric shock, please follow the precautions below.

Safety

- Operate the projection TV only on 120 V AC.
- One blade of the plug is wider than the other for safety purposes and will fit into the power outlet only one way. If you are unable to insert the plug fully into the outlet, contact your dealer.
- Should any liquid or solid object fall into the cabinet, unplug the projection TV and have it checked by qualified personnel before operating it further.
- Unplug the projection TV from the wall outlet if you are not going to use it for several days or more. To disconnect the cord, pull it out by the plug. Never pull the cord itself.

For details concerning safety precautions, see the supplied leaflet "IMPORTANT SAFEGUARDS."

Note on cleaning

Clean the cabinet of the projection TV with a dry soft cloth. To remove dust from the screen, wipe it gently with a soft cloth using vertical strokes only. Stubborn stains may be removed with a cloth slightly dampened with solution of mild soap and warm water. Never use strong solvents such as thinner or benzine for cleaning. If the picture becomes dark after using the projection TV for a long period of time, it may be necessary to clean the inside of the projection TV. Consult qualified service personnel.

Installing

- To prevent internal heat build-up, do not block the ventilation openings.
- Do not install the projection TV in a hot or humid place, or in a place subject to excessive dust or mechanical vibration.
- Avoid operating the projection TV at temperatures below 5°C (41°F).
- If the projection TV is transported directly from a cold to a warm location, or if the room temperature has changed suddenly, the picture may be blurred or show poor color. This is because moisture has condensed on the mirror or lenses inside. If this happens, let the moisture evaporate before using the projection TV.
- To obtain the best picture, do not expose the screen to direct illumination or direct sunlight. It is recommended to use spot lighting directed down from the ceiling or to cover the windows that face the screen with opaque drapery. It is desirable to install the projection TV in a room where the floor and walls are not of reflecting material. If necessary, cover them with dark carpeting or wall paper.

Step 1: Installing the projection TV

For the best picture quality, install the projection TV within the areas shown below.

Optimum viewing area (Horizontal)

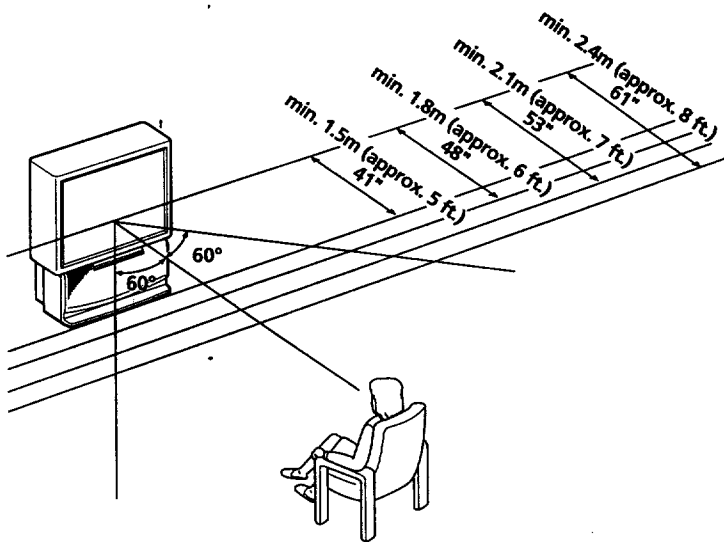

Optimum viewing area (Vertical)

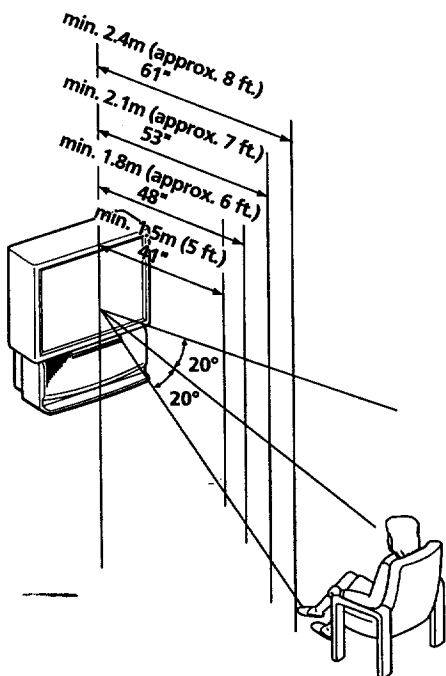

Carrying your projection TV

■ KP-41T65I48S65I53S65 only

Be sure to grasp the areas indicated when carrying the projection TV, and to use more than two people.

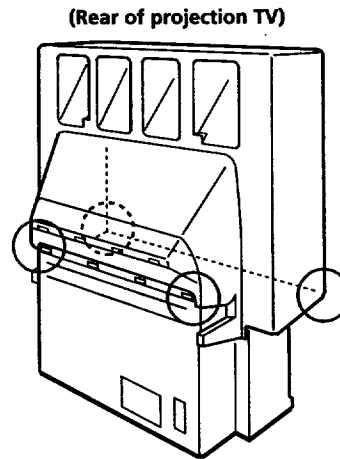

■ KP-61S65 only

Carry your projection TV by the casters.

EN

Preparing for your projection TV

Before you use your projection TV, adjust convergence. For the procedure, see "Step 4: Setting up the projection TV automatically (AUTO SET UP)" on page 14.

Step 2: Hookup

Although you can use either an indoor or outdoor antenna with your projection TV, we recommend that you connect an outdoor antenna or a cable TV system to get better picture quality.

Connecting an antenna

Connect your antenna cable to the VHF/UHF antenna terminal. If you cannot connect your antenna cable directly to the terminal, follow one of the instructions below depending on your cable type.

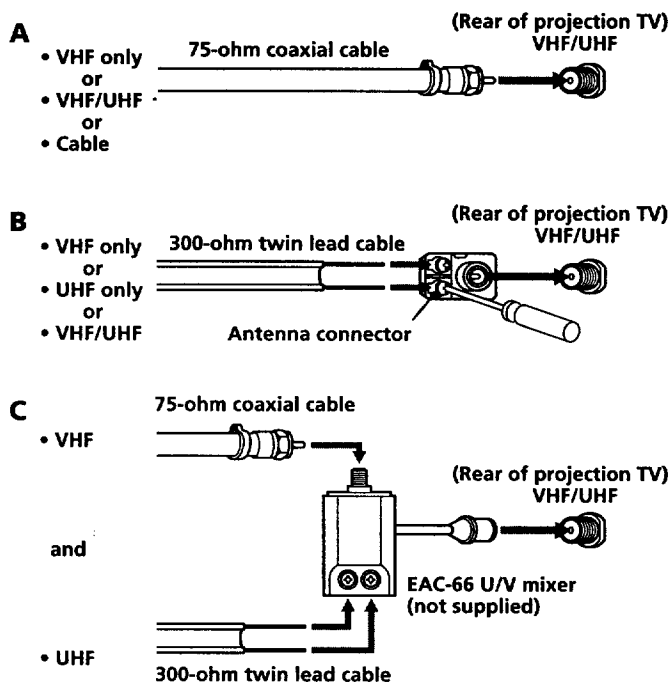

Notes

- Most VHF/UHF combination antennas have a signal splitter. Remove the splitter before attaching the appropriate connector.
- If you use the U/V mixer, snow and noise may appear in the picture when viewing cable TV channels over 37.

Connecting an antenna/cable TV system without a VCR

To cable or antenna

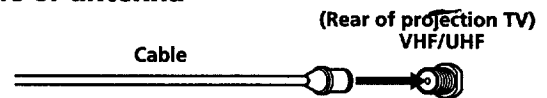

To cable box

If your cable company requires you to connect a cable box, make the connection as follows:

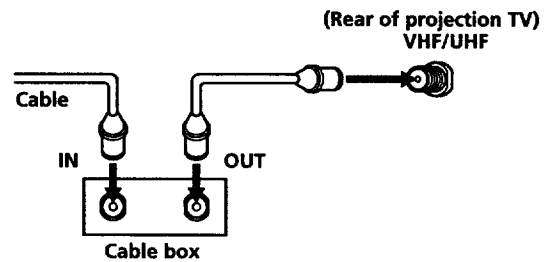

To cable box and cable

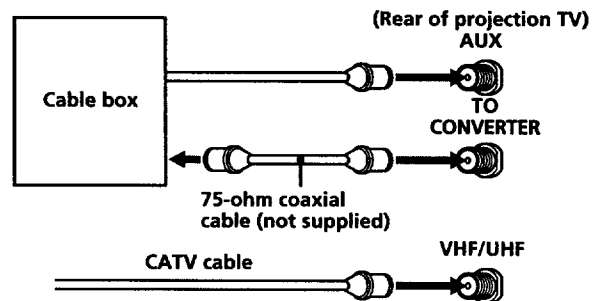

Pay cable TV systems use scrambled or encoded signals requiring a cable box* in addition to the normal cable connection.

* The cable box will be supplied by the cable company.

Note

- You cannot watch the signal through an AUX connector as a window picture.

To cable and antenna

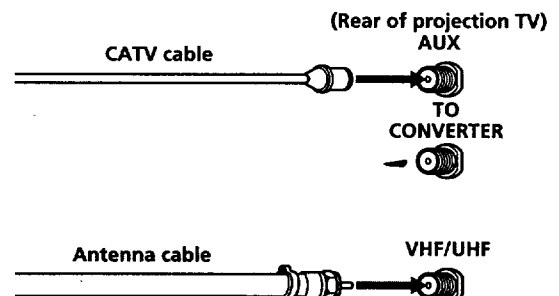

Note

- Do not connect anything to the TO CONVERTER connector in this case.

Connecting an antenna/cable TV system with a VCR

For details on connection, see your VCR instruction manual.

Before making the connection, disconnect the AC power cords of the equipment to be connected.

To a conventional VCR

Notes

- To connect a monaural VCR, connect the audio output of the VCR to AUDIO-L (MONO) of VIDEO 1/2/3 IN on the projection TV.

After making these connections, you will be able to do the following:

- View the playback of video tapes
- Record one TV program while viewing another program
- Watch two TV programs at once using PIP

Without a cable box

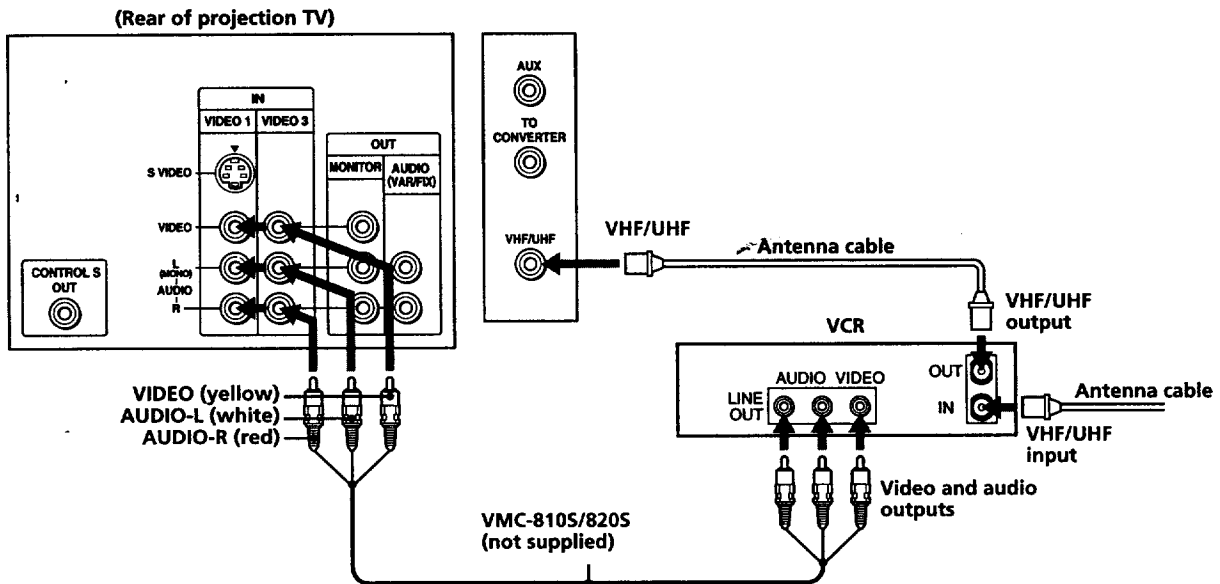

With a cable box

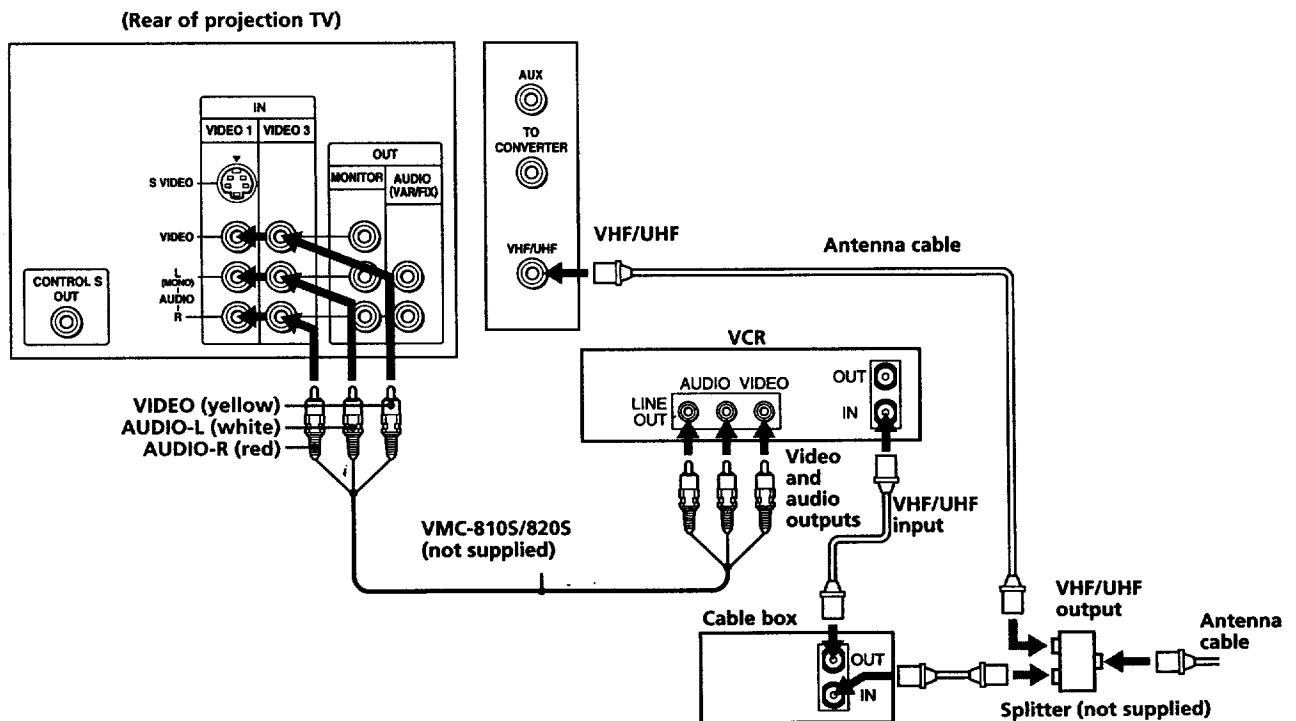

EN

To an S video equipped VCR

If your VCR has an S VIDEO output connector, make the following connections.

Whenever you connect the cable to the S VIDEO input connector, the projection TV automatically receives S video signals.

Without a cable box

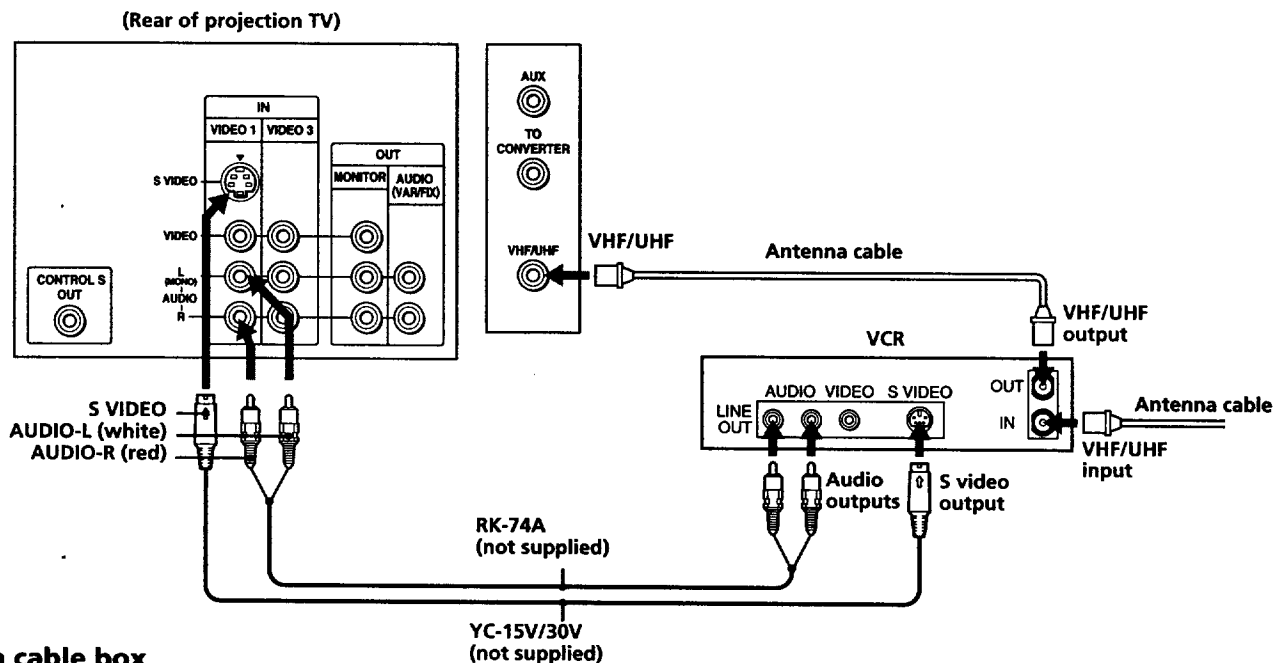

With a cable box

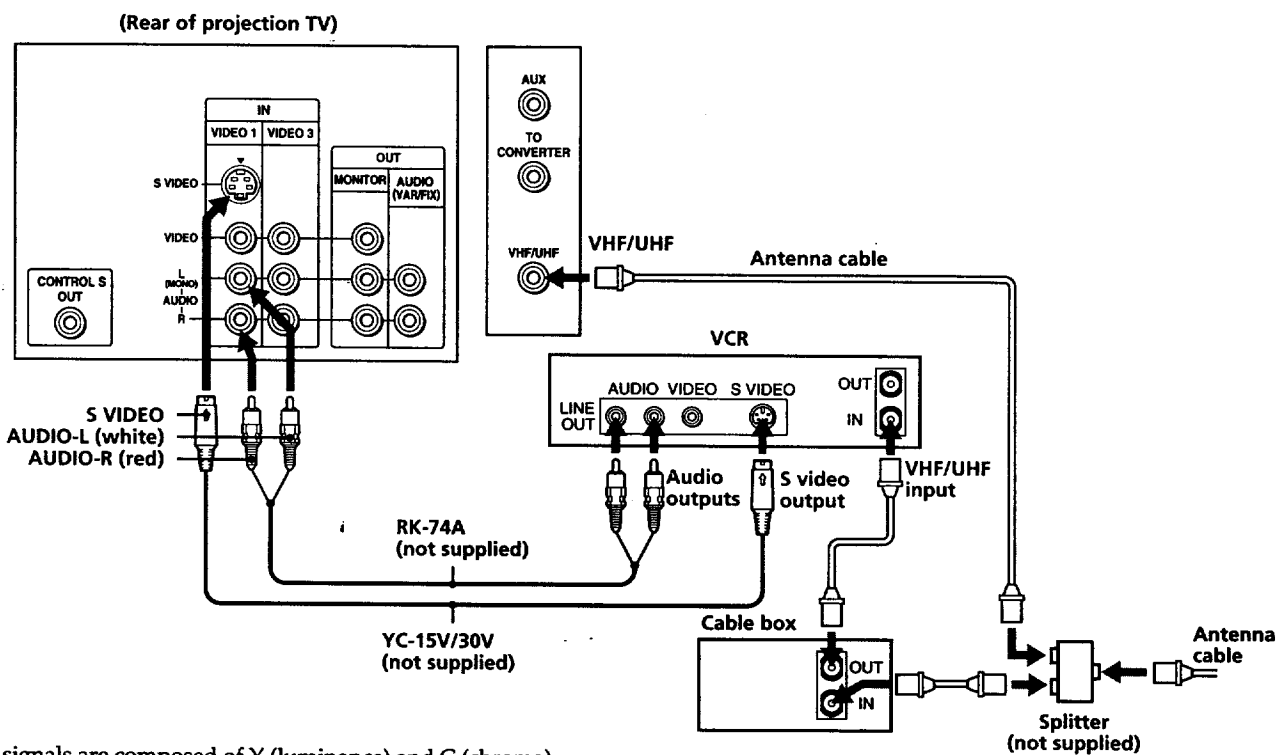

Note

- Video signals are composed of Y (luminance) and C (chroma) signals. The S connection sends the two signals separately preventing degradation, and gives better picture quality compared to conventional connections.

Connecting a DBS receiver

For details on connection, see the instruction manual of the DBS (Digital Broadcasting Satellites) receiver.

To a projection TV

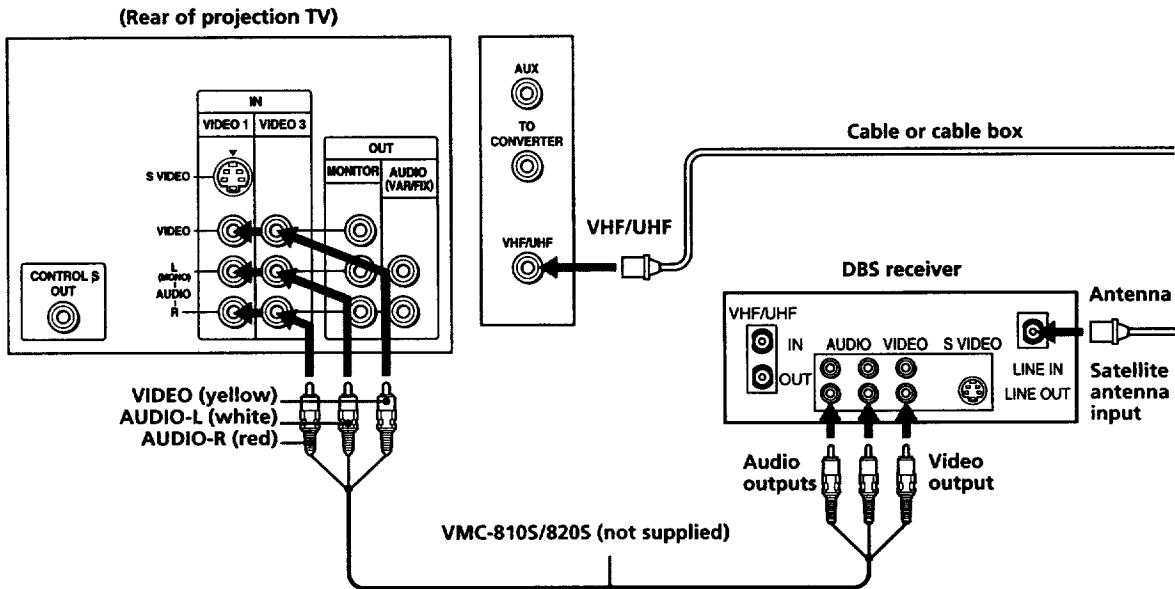

Note

- You can use the S VIDEO connector or the composite video connector for the video connection.

To a projection TV and VCR

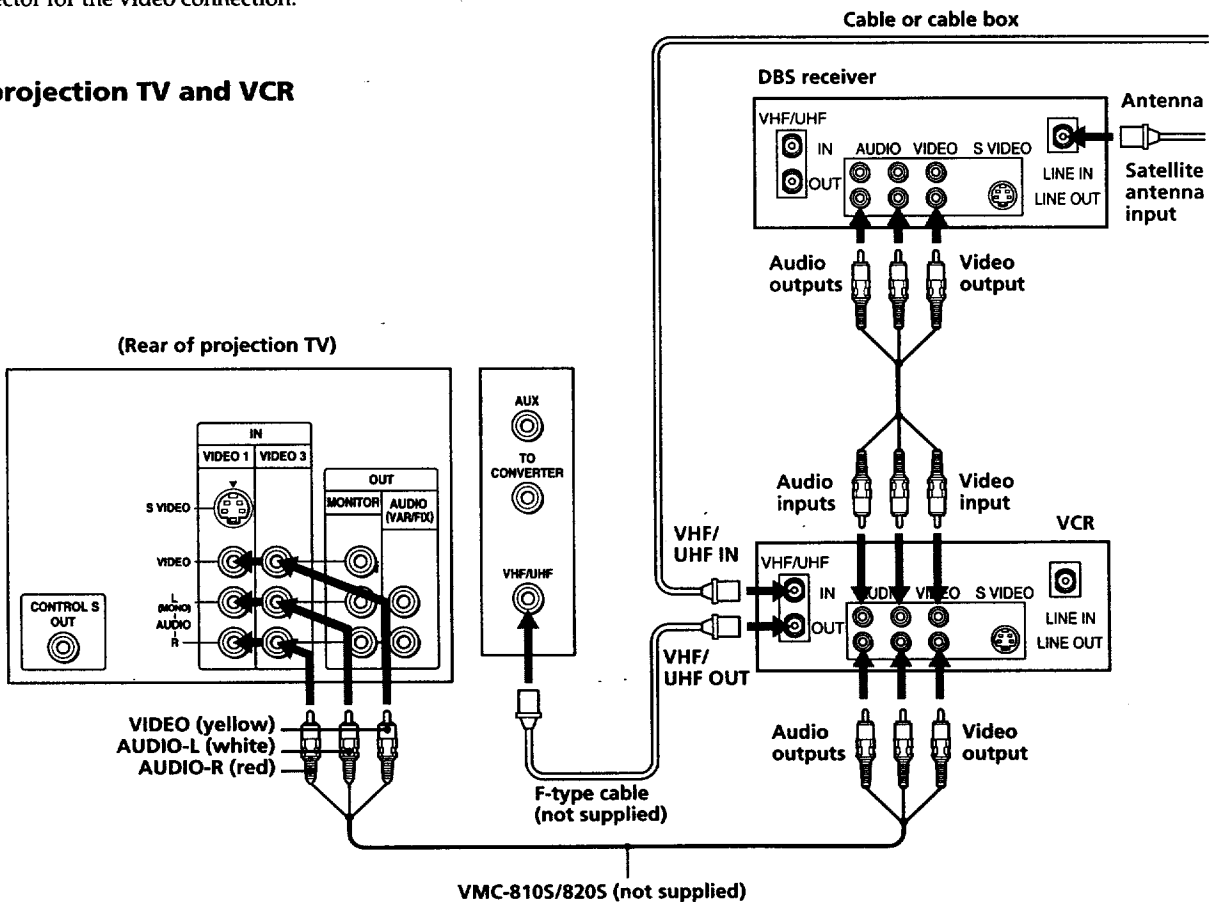

EN

Connecting a camcorder

Use this connection to view a camcorder picture.

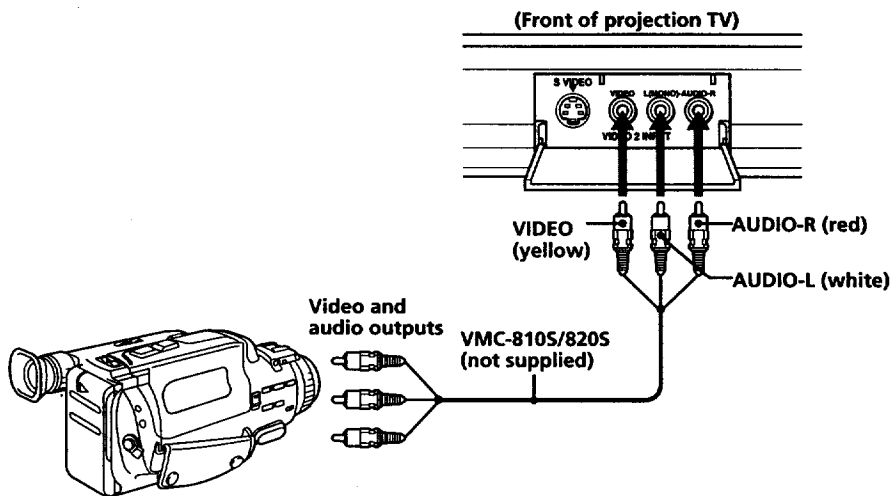

Note

- To connect a monaural camcorder, connect the audio output of the camcorder to AUDIO-L (MONO) of VIDEO 2 INPUT on the projection TV.

Connecting an audio system

When connecting audio equipment, see page 28 for more information.

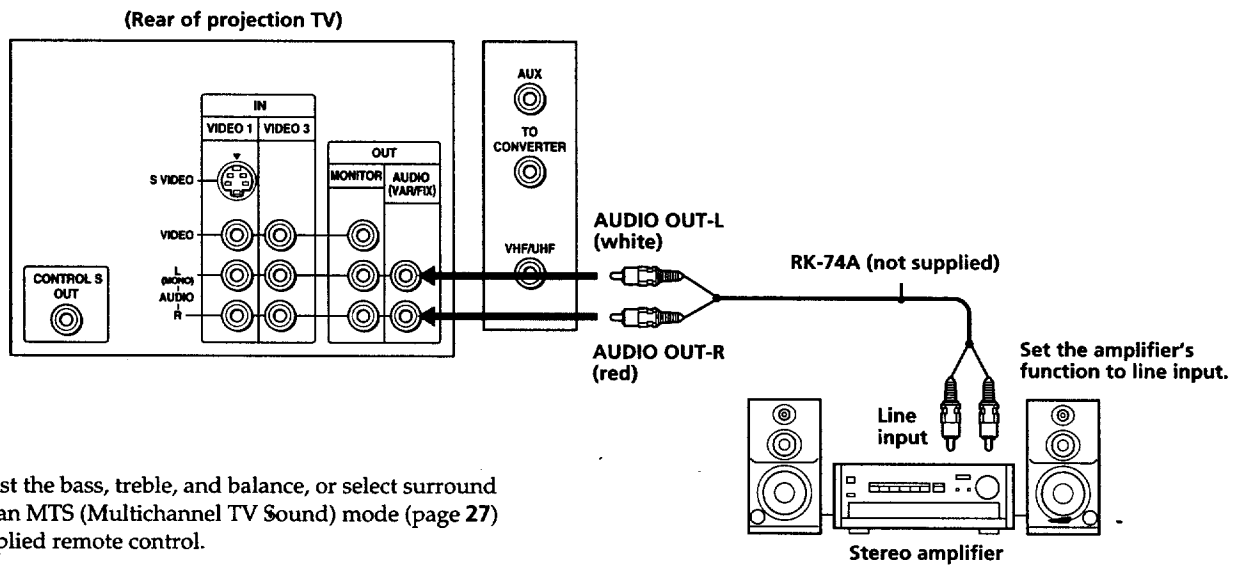

Note

- You can adjust the bass, treble, and balance, or select surround (page 26) or an MTS (Multichannel TV Sound) mode (page 27) with the supplied remote control.

Connecting two VCRs for tape editing using MONITOR OUT

You can record input images displayed on the screen. This type of connection should be used only when you connect from the line input of one VCR, and from the line output of a second VCR.

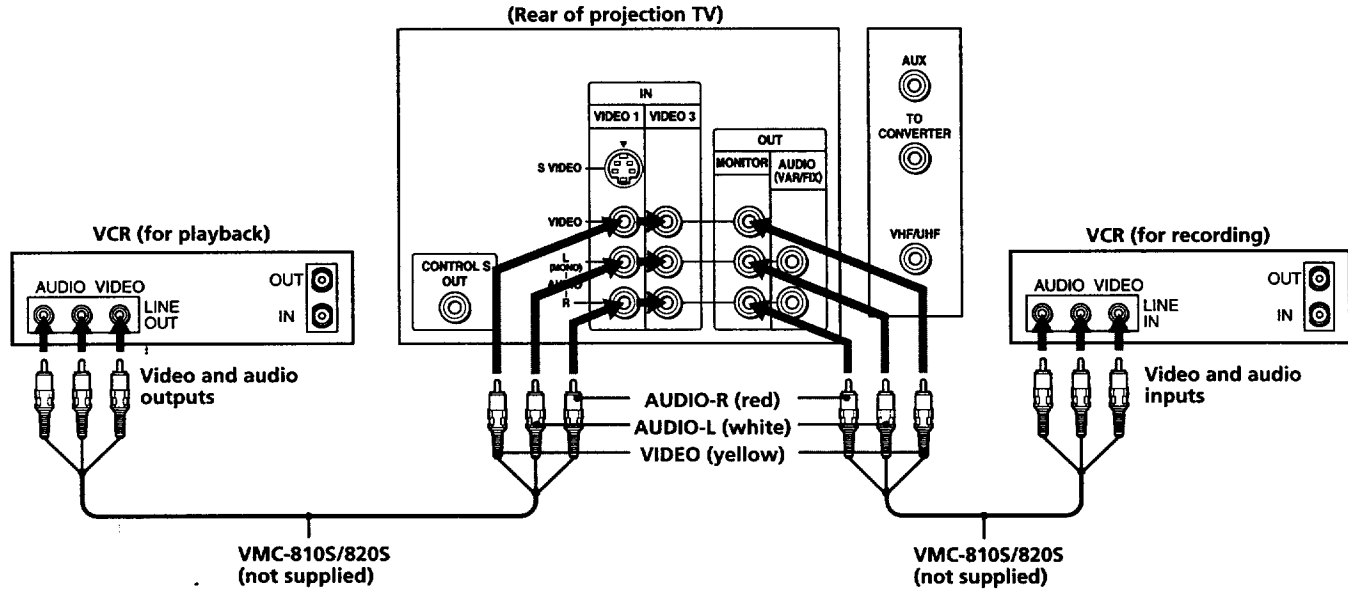

EN

Notes

- Do not change the input signal while editing through MONITOR OUT, or the output signal will also change.
- You can use the S video jack to connect a VCR for playback and the composite video connector to connect a VCR for recording.
- When connecting a single VCR to the projection TV, do not connect the MONITOR OUT to the VCR's line input, while at the same time connecting from the projection TV's VIDEO IN connectors to the VCR's line output, as shown below.

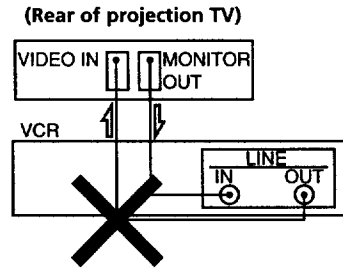

Connecting a Sony SAVA series speaker system

If you have a Sony SAVA series speaker system, connect your speakers to the AUDIO (VAR/FIX) OUT jacks on the rear of the projection TV with the audio cable supplied with the speakers. You can take advantage of the speakers' Dolby Pro Logic* surround system and super woofer mode, and control them with the supplied remote control. When connecting a Sony SAVA series speaker system, see page 27 for more information.

* Manufactured under license from Dolby Laboratories Licensing Corporation. Additionally licensed under Canadian patent number 1,037,877. "Dolby," the double-D symbol  and "Pro Logic" are trademarks of Dolby Laboratories Licensing Corporation.

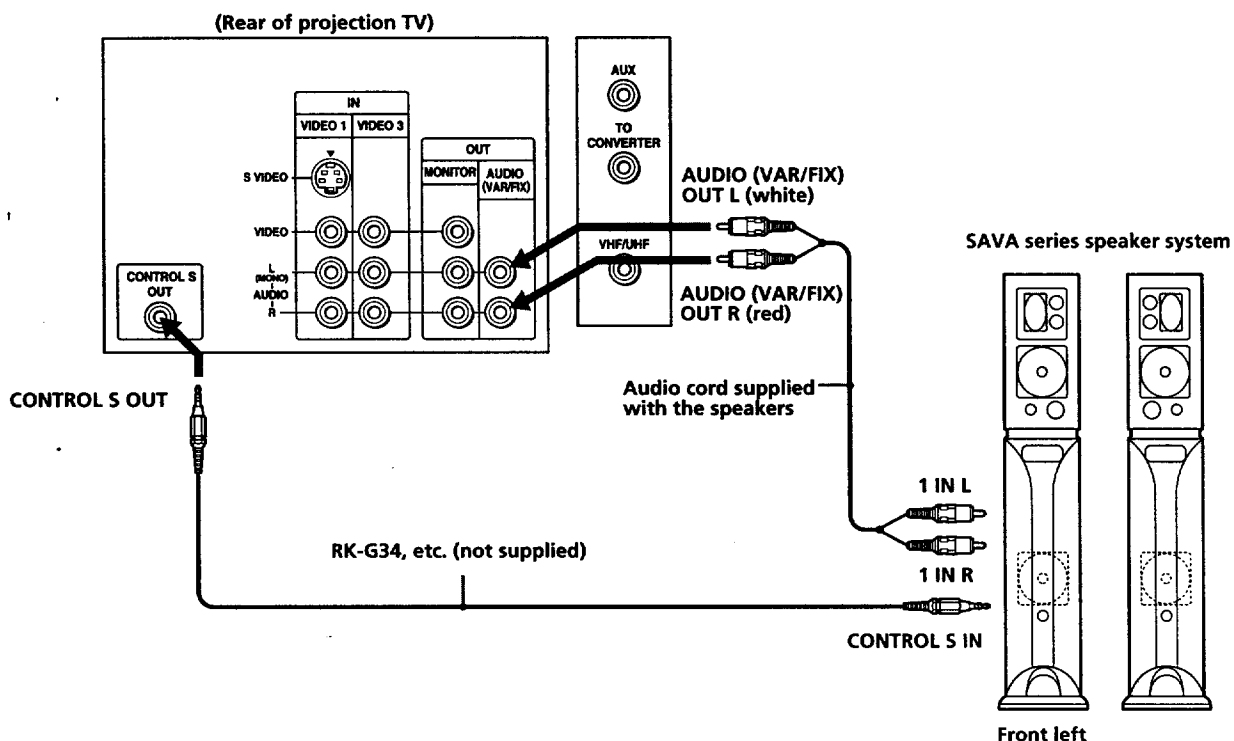

Step 3: Setting up the remote control

Inserting batteries

Insert two size AA (R6) batteries (supplied) by matching the + and - on the battery to the diagram inside the battery compartment.

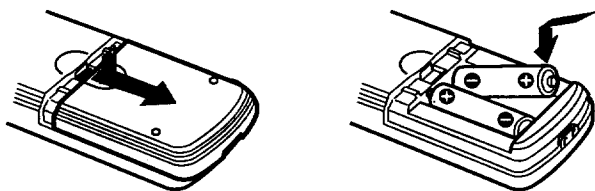

Notes

- Under normal conditions, batteries will last up to six months. If the remote control does not operate properly or the indicators of the buttons on the remote control do not light up, the batteries may be worn out. When replacing batteries, replace both of them with new ones.
- Do not mix old batteries with new ones or mix different types of batteries together.
- If the electrolyte inside the battery should leak, wipe the contaminated area of the battery compartment with a cloth and replace the old batteries with new ones. To prevent the electrolyte from leaking, remove the batteries when you don't plan to use the remote control for a long period of time.
- Do not handle the remote control roughly. Do not drop it, step on it, or let it get wet.
- Do not place the remote control in direct sunlight, near a heater, or where the humidity is high.

Getting to know buttons on the remote control

Names of buttons on the remote control are indicated in different colors to represent the available functions.

Button color

Transparent TV/VCR/DBS/Cable box function (light up) buttons. Press the appropriate function button first to change the remote control's function.

Green Buttons relevant to power operations.

Label color

White TV/VCR/DBS/Cable box operation buttons.

Yellow PIP operation buttons.

Blue DBS operation buttons.

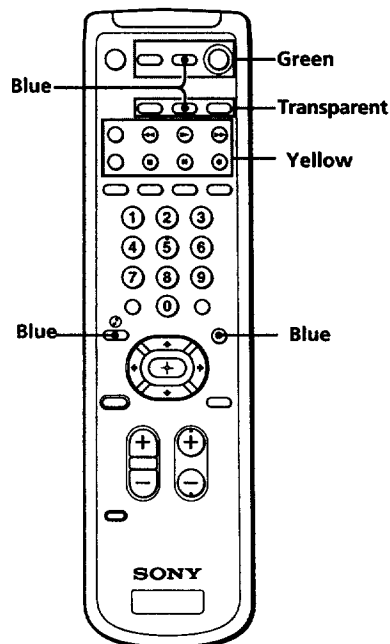

EN

Step 4: Setting up the projection TV automatically

(AUTO SET UP)

You can set up your projection TV easily by using the AUTO SET UP feature. It presets all the receivable channels, adjusts the convergence and changes the on-screen menu language. To set up the projection TV manually, see "Adjusting convergence" (page 16), "Setting cable TV on or off" (page 17), "Presetting channels" (page 18) and "Changing the menu language" (page 18).

If the projection TV is set to a video input, you cannot perform AUTO SET UP. Press TV/VIDEO so that a channel number appears.

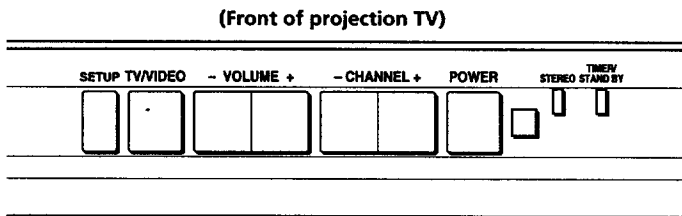

Before you start using AUTO SET UP, be sure to connect the antenna or cable to the projection TV (see page 6).

1 Press POWER to turn the projection TV on.



2 Press SETUP on the front of the projection TV.

AUTO SET UP screen appears.

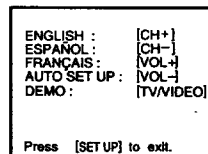

3 Press CHANNEL +/- or VOLUME + to select the on-screen menu language.

If you prefer Spanish or French to English, you can change the on-screen menu language.

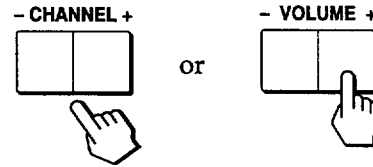

All of the menus will be set to the factory preset condition in the selected language.

4 Press VOLUME - to start AUTO SET UP.

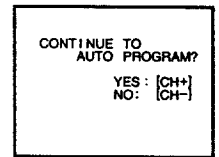
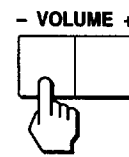

5 Press CHANNEL + to preset channels.

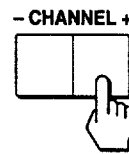

"AUTO PROGRAM" appears on the screen and the TV starts scanning and presetting channels automatically. When all the receivable channels are stored, "AUTO PROGRAM" disappears and the following menu appears. If the projection TV receives cable TV channels, CABLE is set to ON automatically.

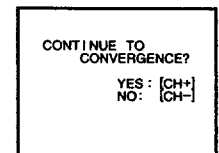

To exit AUTO PROGRAM

Press any button.

6 Adjust convergence.

(1) Press CHANNEL +.

The CONVERGENCE adjustment screen appears.

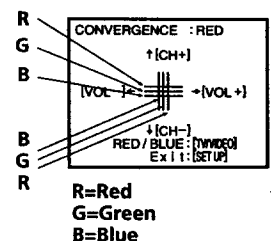
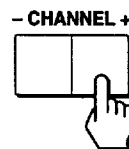

(2) Press TV/VIDEO to select RED or BLUE.

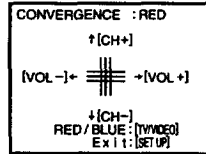

(3) Using CHANNEL +/- or VOLUME +/-, move the line until it converges with the center green line.

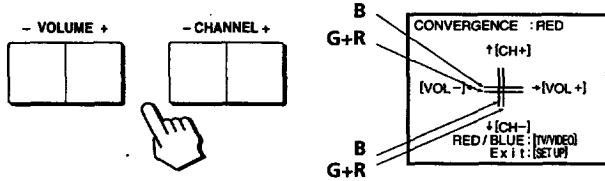

To move horizontal line up/down, press CHANNEL +/-!
To move vertical line right/left, press VOLUME +/-.

(4) Repeat steps (2) and (3) to adjust the other lines until all three lines converge and are seen as a white cross.

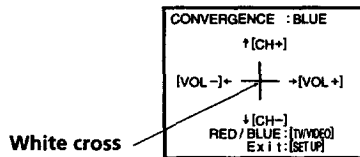

Note

- Using the AUX connector, press TV (black-button) first and make sure that "AUX" is displayed beside the channel number on the screen. Then follow the steps 2 to 6 above to perform AUTO SET UP.

To preview the main functions (DEMO)

Press TV/VIDEO on the projection TV in step 4. The functions and menus are displayed one by one.

To exit DEMO

Press any button.

Erasing or adding channels

After AUTO SET UP, you can erase unnecessary channels or add the channels you want. Preset channels during the day rather than late at night, when some channels may not be broadcasting.

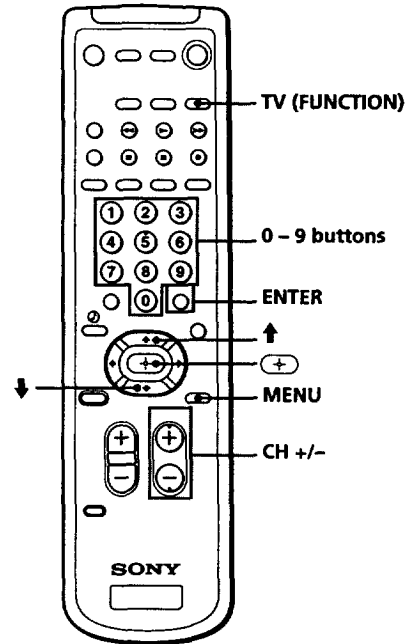

EN

1 Press TV (FUNCTION).

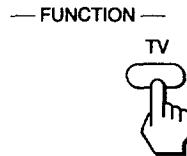

2 Press MENU.

The main menu appears.



3 Press ↑ or ↓ to select [MENU], and press (+).

The SET UP menu appears.

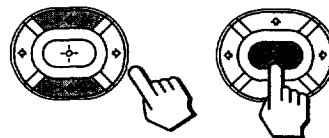

4 Press ↑ or ↓ to select CHANNEL ERASE/ADD, and press (+).

The CHANNEL ERASE/ADD menu appears.

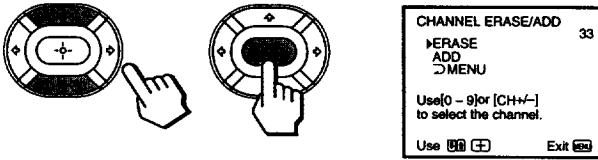

6 To erase and/or add other channels, repeat step 5.

7 Press MENU to return to the original screen.



Notes

- If you erase or add a VHF or UHF channel, the cable TV channel with the same number is also erased or added, and vice versa.
- Erasing and adding channels is also available for the AUX input.

5 Erase and/or add channels:

To erase an unwanted channel

- (1) Make sure the cursor (▶) is beside ERASE.
- (2) Press CH +/- or the 0-9 buttons to select the channel you want to erase, and press ENTER.

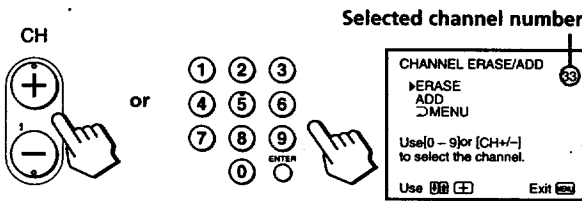

- (3) Press (+).
The "-" indication appears beside the channel number, showing that the channel is erased from the preset memory.



To add a channel that you want

- (1) Press ↑ or ↓ to move the cursor (▶) to ADD.
- (2) Press the 0-9 buttons to select the channel you want to add, and press ENTER.

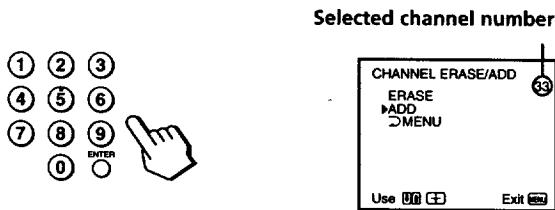

- (3) Press (+).
The "+" indication appears beside the channel number, showing that the channel is added to the preset memory.



Adjusting convergence (CONVERGENCE)

The projection tube image appears on the screen in three layers (red, green and blue). If they do not converge, the color is poor and the picture blurs. To correct this, adjust convergence.

You do not have to do this procedure if you perform AUTO SET UP (page 14). Do this procedure only when you want to adjust it manually.

1 Press MENU.

2 Press ↑ or ↓ to select (CONV), and press (+).

3 Press ↑ or ↓ to select CONVERGENCE, and press (+).

The CONVERGENCE adjustment screen appears.

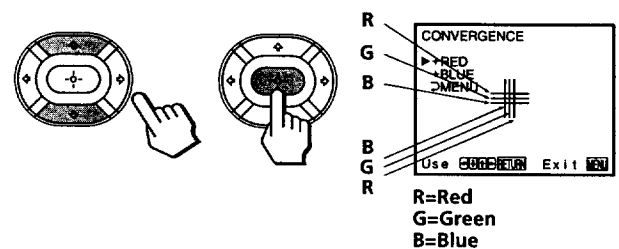

- 4** Press \uparrow , \leftarrow , \downarrow , or \rightarrow to move the cursor (\blacktriangleright) to the symbol showing the line you want to adjust, and press \odot .

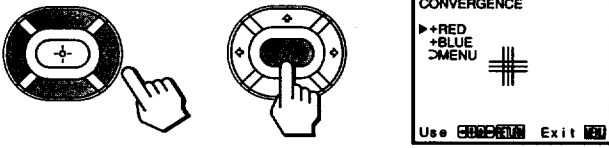

+RED : Red vertical and horizontal line (left/right/up/down adjustment)
 +BLUE : Blue vertical and horizontal line (left/right/up/down adjustment)

- 5** Press \uparrow , \leftarrow , \downarrow , or \rightarrow to move the line until it converges with the center green line, and press \odot .

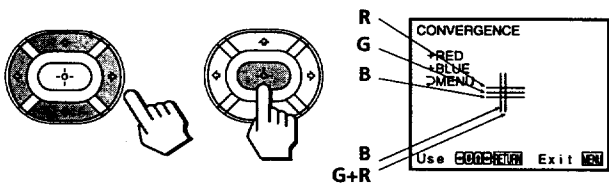

To move	Press
Up	\uparrow
Down	\downarrow
Right	\rightarrow
Left	\leftarrow

- 6** Repeat steps 4 and 5 to adjust the other lines until all three lines converge and are seen as a white cross.
- 7** Press MENU to return to the original screen.

Setting cable TV on or off

If you have connected the projection TV to a cable TV system, set CABLE to ON (the factory setting). If not, set CABLE to OFF.

You do not have to do this procedure if you perform AUTO SET UP (page 14). Do this procedure only when you want to set it manually.

- 1 Press MENU.**
- 2 Press \uparrow or \downarrow to select SET UP , and press \odot .**
- 3 Set CABLE to ON or OFF:**
 - Press \uparrow or \downarrow to move the cursor (\blacktriangleright) to CABLE, and press \odot .
 - Press \uparrow or \downarrow to select ON or OFF, and press \odot .

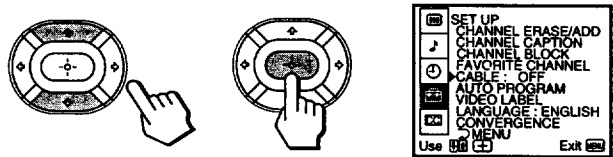

- 4 Press MENU to return to the original screen.**



Note

- If CABLE appears in gray, the projection TV is set to a video input and you cannot select CABLE. Press TV (black button) so that a channel number appears.

Presetting channels

You can preset TV channels easily by using the AUTO PROGRAM feature.

You do not have to do this procedure if you perform AUTO SET UP (page 14). Do this procedure only when you want to set it manually.

- 1 Press **MENU**.
- 2 Press **↑** or **↓** to select , and press .
- 3 Press **↑** or **↓** to select **AUTO PROGRAM**, and press .

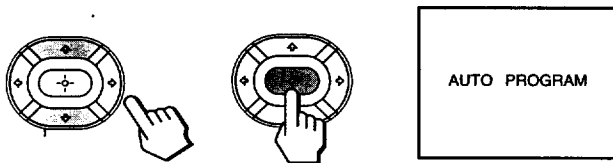

"AUTO PROGRAM" appears on the screen and the projection TV starts scanning and presetting channels automatically. When all the receivable channels are stored, "AUTO PROGRAM" disappears and the lowest numbered channel is displayed.

- 4 Press **MENU** to return to the original screen.

To exit AUTO PROGRAM

Press any button.



Notes

- If the AUTO PROGRAM menu appears in gray, the projection TV is set to a video input and you cannot select AUTO PROGRAM. Press ANT so that a channel number appears.
- Presetting channels is also available for the AUX input.

Changing the menu language

If you prefer Spanish or French to English, you can change the menu language.

You do not have to do this procedure if you select the language during AUTO SET UP (page 14). Do this procedure only when you want to set it manually.

- 1 Press **MENU**.
- 2 Press **↑** or **↓** to select , and press .
- 3 Press **↑** or **↓** to select **LANGUAGE**, and press .

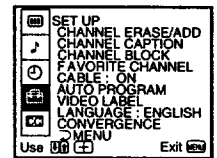
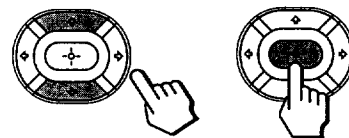

- 4 Press **↑** or **↓** to select your favorite language, "ENGLISH", "ESPAÑOL," or "FRANÇAIS" and press .

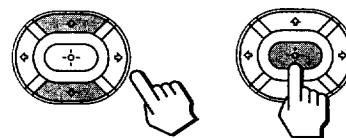

- 5 Press **MENU** to return to the original screen.

Note

- Certain parts of the Spanish or French menus remain in English.

Watching the TV

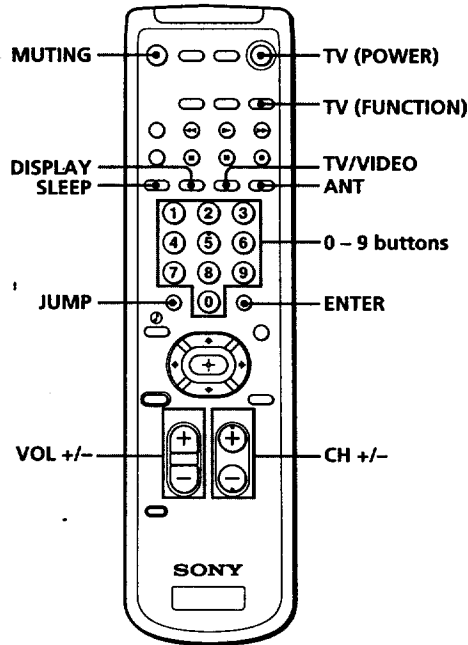

1 Press TV (POWER) to turn on the projection TV.

The TIMER/STANDBY indicator flashes until the picture appears.



If "VIDEO" appears on the screen, press ANT so that a channel number appears.

2 Press TV (FUNCTION).

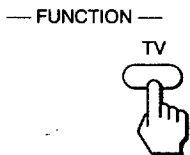

Once you press TV (FUNCTION), the projection TV function is set unless another function button is pressed.

3 Select the channel you want:

To select a channel directly

Press the 0 - 9 buttons, and press ENTER. For example, to select channel 10, press 1, 0 and ENTER.

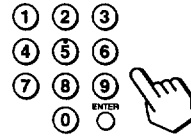

To scan through channels

Press CH +/- until the channel you want appears.

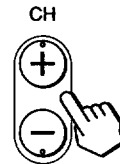

The channel can also be selected without pressing ENTER.

4 Press VOL +/- to adjust the volume.

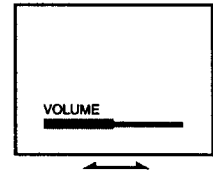
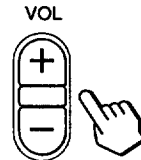

EN

Switching quickly between two channels

You can use the JUMP button to switch or "jump" back and forth between two channels.

Press JUMP.



Pressing JUMP again switches the channel back to the one you selected last.

Note

- You cannot jump to channels you scanned through using the CH +/- buttons.

Muting the sound

Press MUTING.

"MUTING" appears on the screen.



To restore the sound, press MUTING again, or press VOL +.

Watching two programs at one time — PIP

The Picture-in-Picture (PIP) feature allows you to watch both the main picture and a window picture simultaneously.

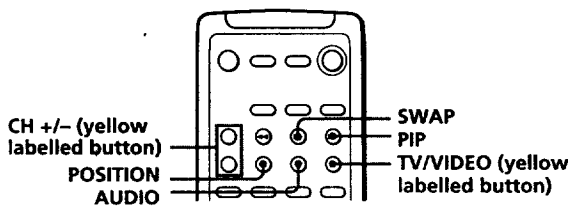

Use the yellow labelled buttons for PIP operations.

Displaying a window picture

Press PIP.

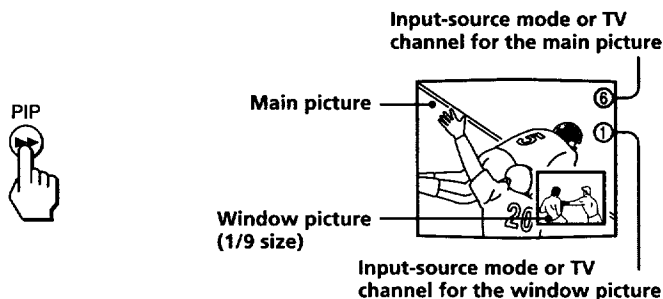

Press PIP again to display a smaller window picture.

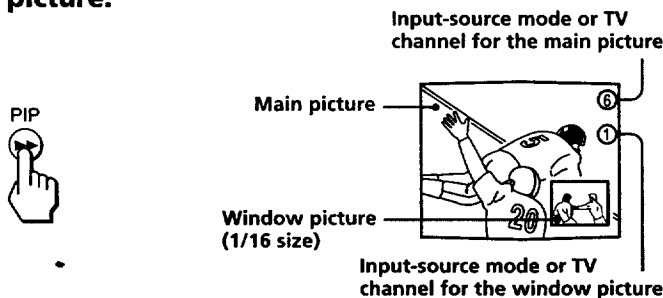

To remove the window picture, press PIP again.

Note

- The window picture may be affected by the condition of the main picture.

Changing the window picture input mode

Press TV/VIDEO (yellow labelled button) to select the input mode.

Each time you press TV/VIDEO (yellow labelled button), "TV", "VIDEO 1", "VIDEO 2", and "VIDEO 3" appear in sequence.

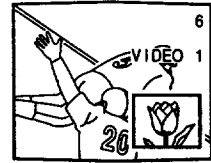

A window picture will appear in the same input mode as the last time you used PIP.

Note

- If you connect your VCR without a cable box, your PIP input source is a VCR. If you connect your VCR with a cable box, your PIP input source is a VCR or cable box.

Listening to the sound of the window picture

Press AUDIO.

The display appears next to the PIP channel number for a few seconds, indicating that the window picture sound is being received.

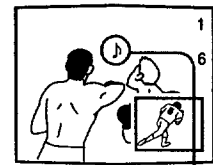

The sound of the window picture is received.

To restore the main picture sound, press AUDIO again. The display moves to the main picture channel number.

Changing TV channels in the window picture

Press CH +/- (yellow labelled button).

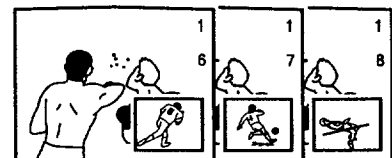
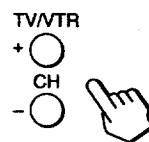

Changing the position of the window picture

Press POSITION.

Each time you press POSITION, the window picture will move counterclockwise on the screen.



Swapping the main and window pictures

Press SWAP.

Each time you press SWAP, the images and sound from the main and window pictures switch places with another.

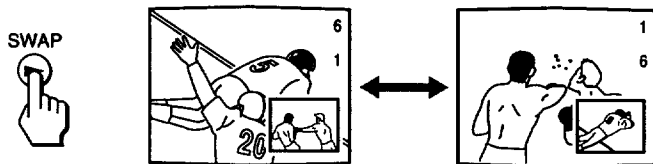

Note

- The channels being received through the AUX connector cannot be displayed as a window picture.

Freezing the picture (FREEZE)

The FREEZE feature is useful when you want to write down an information such as a recipe from a cooking program, a displayed address, or a phone number. The frozen picture changes as follows depending on whether the PIP function is used or not.

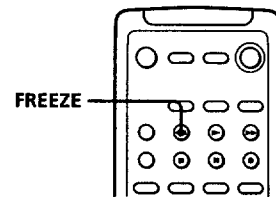

Press FREEZE.



When the PIP function is not being used

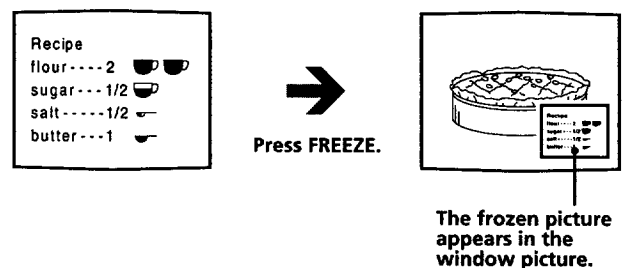

To remove the frozen window picture, press FREEZE again.

When the PIP function is being used

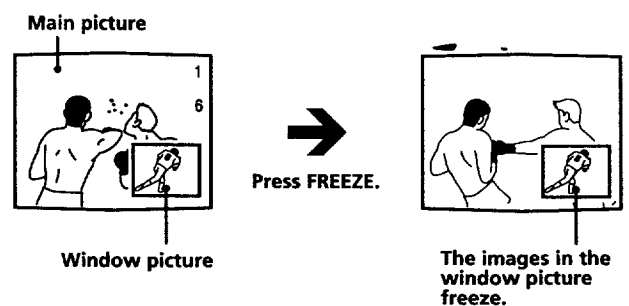

To cancel the frozen window picture, press FREEZE again.

Adjusting the picture (VIDEO)

When watching TV programs, you can adjust the picture to suit your taste. You can adjust the picture of video input(s) as well.

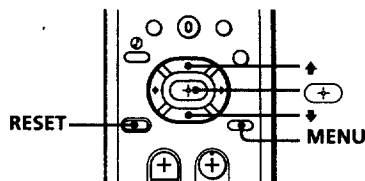

1 Press MENU.

2 Press ↑ or ↓ to select , and press .

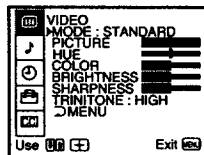
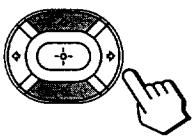

3 Select the item you want to adjust.

For example:

(1) To adjust the brightness, press ↑ or ↓ to move the cursor (▶) to BRIGHTNESS.

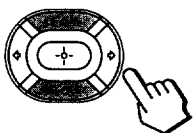

(2) Press .



4 Adjust the selected item:

(1) Press ↑, ↓, ←, or → to adjust the item.

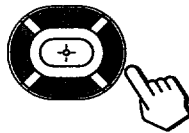

(2) Press .

The new setting appears in the VIDEO menu.



For details on each item, see "Description of adjustable items" below.

5 To adjust other items, repeat steps 3 and 4.

6 Press MENU to return to the original screen.

EN

Description of adjustable items

Item	Press ↑ or ↓ to	Press → or ← to
PICTURE	Decrease picture contrast and give soft color.	Increase picture contrast and give vivid color.
HUE	Make picture tones become purplish.	Make picture tones become greenish.
COLOR	Decrease color intensity.	Increase color intensity.
BRIGHTNESS	Darken the picture.	Brighten the picture.
SHARPNESS	Soften the picture.	Sharpen the picture.

To restore the factory settings

Press RESET after displaying and selecting the VIDEO menu.

All of the settings are restored to the factory settings.

Adjusting the color temperature (TRINITONE)

The TRINITONE feature controls the color temperature, permitting white balance preference adjustment without affecting skin tones.

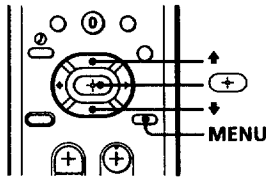

- 1 Press **MENU**.
- 2 Press **↑** or **↓** to select **III** and press **+**.
- 3 Press **↑** or **↓** to select **TRINITONE** and press **+**.

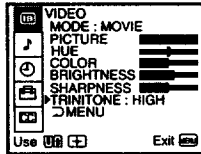
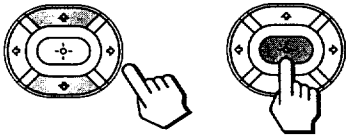

- 4 Press **↑** or **↓** to select **NTSC STD**, **MEDIUM**, or **HIGH** and press **+**.

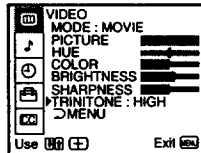
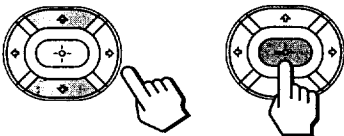

Choose	To
HIGH	a cool (bluish) white.
MEDIUM	a neutral white.
NTSC STD	a warm (reddish) white.

Selecting the video mode (VIDEO)

The video mode feature allows you to choose three different modes of picture settings. Choose the one that best suits the type of program that you want to watch.

- 1 Press **MENU**.
- 2 Press **↑** or **↓** to select **III**, and press **+**.
- 3 Press **↑** or **↓** to select **MODE**, and press **+**.
- 4 Press **↑** or **↓** to select **STANDARD**, **MOVIE**, or **SPORTS** mode, and press **+**.

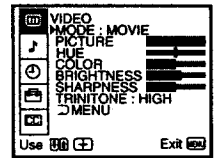
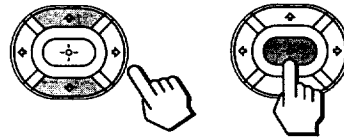

Choose	To
STANDARD	Receive a standard picture.
MOVIE	Receive a finely detailed picture.
SPORTS	Receive a vivid, bright picture.

- 5 Press **MENU** to return to the original screen.

Note

- The settings for these modes can be adjusted in the VIDEO menu.

Adjusting the sound (AUDIO)

You can adjust the quality of the TV sound to suit your taste. You can adjust the sound of the video input(s) as well.

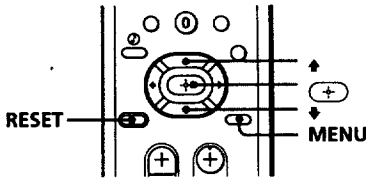

1 Press MENU.

2 Press ↑ or ↓ to select , and press (+).

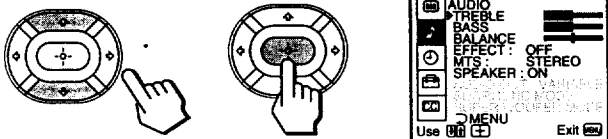

3 Select the item you want to adjust.

For example:

(1) To adjust bass, press ↑ or ↓ to move the cursor (▶) to BASS.



(2) Press (+).



4 Adjust the selected item:

(1) Press ↑, ←, ↓, or → to adjust the item.

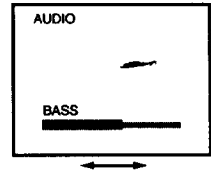
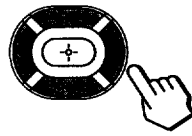

(2) Press (+).

The new setting appears in the AUDIO menu.



For details on each item, see "Description of adjustable items" below.

5 To adjust other items, repeat steps 3 and 4.

6 Press MENU to return to the original screen.

EN

Description of adjustable items

Item	Press ↓ or ← to	Press ↑ or → to
TREBLE	Decrease the treble response.	Increase the treble response.
BASS	Decrease the bass response.	Increase the bass response.
BALANCE	Emphasize the left speaker's volume.	Emphasize the right speaker's volume.

To restore the factory settings

Press RESET after displaying and selecting the AUDIO menu.

All of the settings are restored to the factory settings.

Note

- When SPEAKER (page 27) is OFF and AUDIO OUT (page 28) is in the FIXED condition, the volume, TREBLE, BASS, and BALANCE cannot be adjusted.

Using audio effect (SURROUND)

The audio effect (SURROUND) feature simulates sound reproduction with the atmosphere of a movie theater or a concert hall. Audio effect is only effective for stereo programs.

Using the (audio effect) button

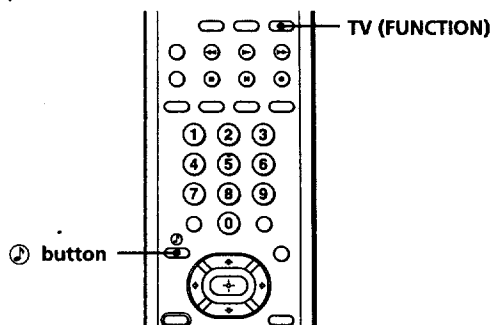

1 Press TV (FUNCTION).

2 Press .

Each time you press the  button, the display changes as follows:

SURROUND → SURROUND OFF

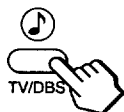

Using the menu to set audio effect

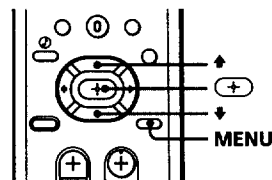

1 Press MENU.

2 Press ↑ or ↓ to select , and press .

3 Press ↑ or ↓ to select EFFECT, and press .

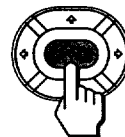
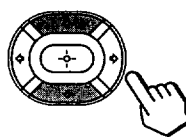

4 Press ↑ or ↓ to select the audio effect mode, and press .

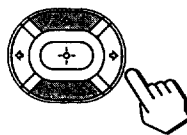

5 Press MENU to return to the original screen.

Selecting stereo or bilingual programs (MTS)

(MTS)

The Multichannel TV Sound (MTS) feature allows you to enjoy stereo sound or Second Audio Programs (SAP) of your choice. The initial setting is stereo sound (STEREO).

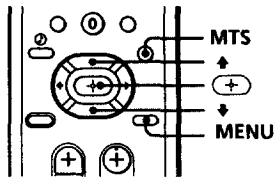

Press MTS repeatedly to select STEREO, SAP, or MONO.

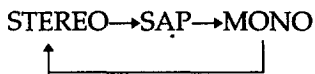

Choose	To
STEREO	Listen to stereo sound. The STEREO indicator on the projection TV lights up when a stereo broadcast is received.
SAP	Listen to bilingual programs. There is no sound when the SAP signal is not broadcasting.
MONO	Listen to monaural sound. Reduce noise during stereo broadcasts.

Note

- Stereo and SAP sounds are subject to program sources.

To set MTS using the menu

- 1 Press MENU.
- 2 Press \uparrow or \downarrow to select \mathbb{J} , and press \odot .
- 3 Press \uparrow or \downarrow to select MTS, and press \odot .
- 4 Press \uparrow or \downarrow to select STEREO, SAP, or MONO.
- 5 Press MENU to return to the original screen.

Setting the speaker switch (SPEAKER)

You may switch off the projection TV speakers when, for example, you want to listen to the sound through a stereo system.

If you connect the Sony SAVA series speaker system to the AUDIO (VAR/FIX) OUT connectors, you can take advantage of the speakers' surround sound and super woofer mode. After making the connections (page 12), set SPEAKER to SAVA SPEAKER, then adjust SURROUND MODE or SUPER WOOFER MODE.

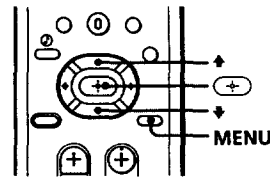

EN

- 1 Press MENU.
- 2 Press \uparrow or \downarrow to select \mathbb{J} , and press \odot .
- 3 Press \uparrow or \downarrow to select SPEAKER, and press \odot .

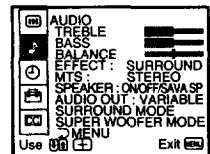
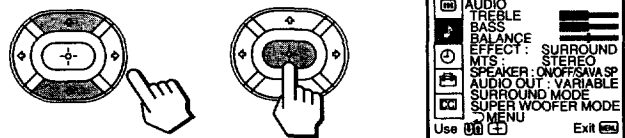

- 4 Press \uparrow or \downarrow to select ON, OFF, or SAVA SP, and press \odot .

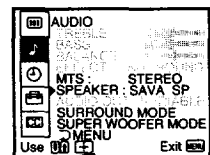
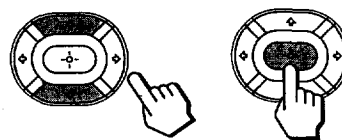

- 5 Press MENU to return to the original screen.

Choose	To
ON	Listen to the sound from the projection TV.
OFF	Turn off the projection TV speaker sound and listen to the projection TV's sound solely through the audio system speakers.
SAVA SP	Turn off the projection TV speaker sound and listen to the projection TV's sound through the Sony SAVA series speaker system. You can adjust volume, muting, surround modes, and super woofer mode with the remote control supplied with the projection TV.

Setting audio out (AUDIO OUT)

You can change AUDIO OUT to VARIABLE or FIXED when SPEAKER is set to OFF. AUDIO OUT is variable when SPEAKER is set to ON.

To select surround sound or super woofer mode of the SAVA speaker system

After setting SPEAKER to SAVA SP, follow the procedure below.

Press **↑** or **↓** to select **SURROUND MODE** or **SUPER WOOFER MODE**, and press **⊕**.

For details on each option, refer to the operating instructions of the speaker system.

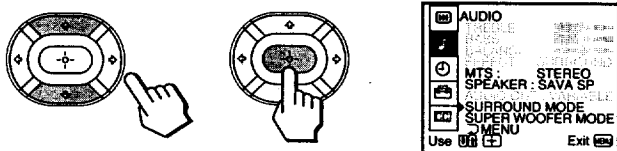

Note

- This feature is only for Sony SAVA speaker system with an operation capability for KP-41T65, KP-48S65, KP-53S65, and KP-61S65.

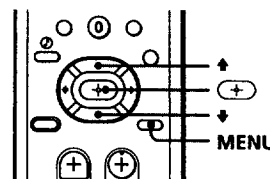

- Press **MENU**.
- Press **↑** or **↓** to select **♪**, and press **⊕**.
- Press **↑** or **↓** to select **AUDIO OUT**, and press **⊕**.

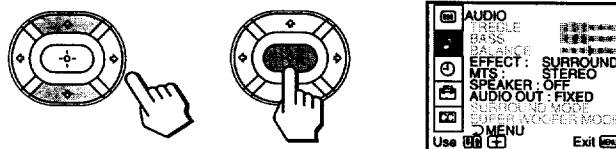

- Press **↑** or **↓** to select **VARIABLE** or **FIXED**, and press **⊕**.

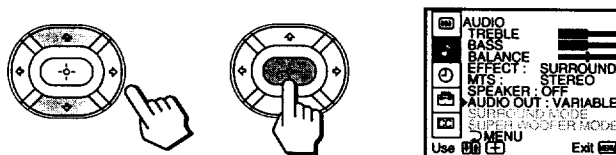

VARIABLE: Sound output varied according to the projection TV settings. You can adjust the volume, bass, treble, and balance.

FIXED: Sound output is always fixed to a certain level. The volume, bass, treble, and balance are also fixed to the factory settings.

- Press **MENU** to return to the original screen.

Note

- If **AUDIO OUT** appears in gray, set **SPEAKER** to **OFF**.

Setting daylight saving time (DAYLIGHT SAVING)

If your area uses daylight saving time, change DAYLIGHT SAVING setting depending on the season, before setting the current time.

Daylight saving start

- After the first Sunday in April, set DAYLIGHT SAVING to YES. Current time setting (right column) automatically moves one hour ahead.

Daylight saving end

- After the last Sunday in October, set DAYLIGHT SAVING to NO. Current time setting automatically moves one hour back.

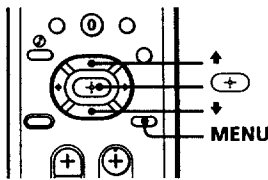

1 Press MENU.

2 Press ↑ or ↓ to select ☉, and press ⏏.

3 Press ↑ or ↓ to select DAYLIGHT SAVING, and press ⏏.

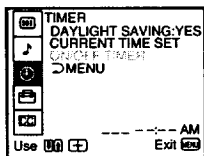
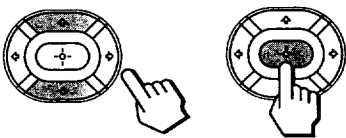

4 Press ↑ or ↓ to select YES or NO, and press ⏏.

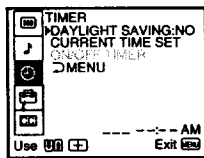
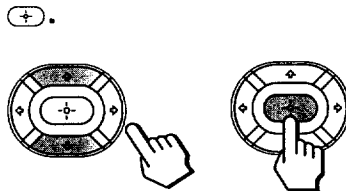

Choose To

YES	Set for daylight saving start.
NO	Set for daylight saving end.

5 Press MENU to return to the original screen.

Setting the clock (CURRENT TIME SET)

Setting the clock enables you to turn the projection TV on and off with the timer. Make sure to set daylight saving time first.

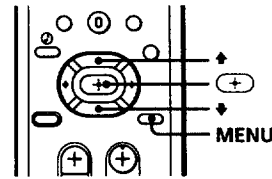

1 Press MENU.

2 Press ↑ or ↓ to select ☉, and press ⏏.

3 Press ↑ or ↓ to select CURRENT TIME SET, and press ⏏.

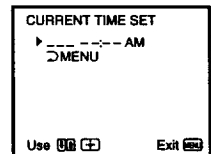
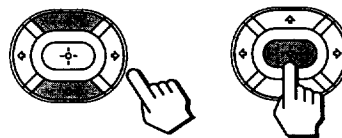

4 Make sure the cursor (▶) is to the left of "--:-- AM," and press ⏏.

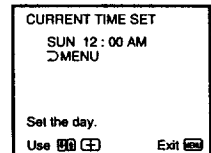
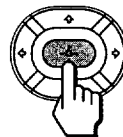

5 Set the current day of the week and time.

(1) Press ↑ or ↓ to set the day of the week, and press ⏏.

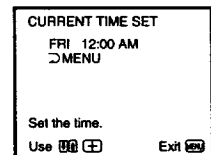
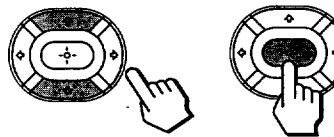

(2) Set the hour and minutes in the same way as in step (1). When you press ⏏ after setting the minutes, the clock starts.

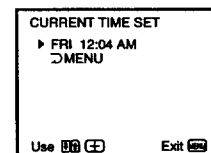
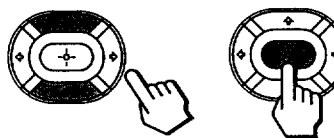

6 Press MENU to return to the original screen.

EN

Setting the timer to turn the projection TV on and off (ON/OFF TIMER)

You can set the projection TV to turn on and off at the times you specify. Make sure the clock is set correctly. If it is not, set the clock first (page 29).

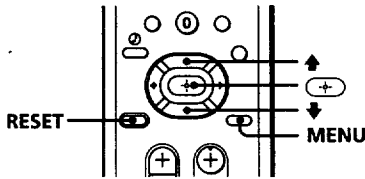

1 Press MENU.

2 Press ↑ or ↓ to select ☉, and press (+).

3 Press ↑ or ↓ to select ON/OFF TIMER, and press (+).

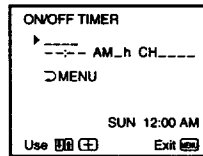
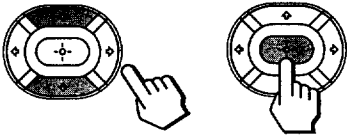

4 Press (+) and enter the ON/OFF TIMER setting.

(1) Press ↑ or ↓ to set the day(s), and press (+).

Each time you press ↑ or ↓, the days cycle as follows:

EVERY SUN-SAT → EVERY MON-FRI → SUNDAY → ... → SATURDAY → EVERY SUNDAY → ... → EVERY SATURDAY

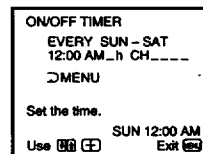
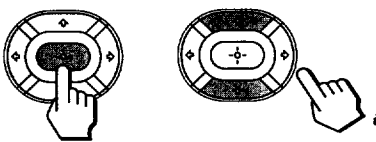

(2) Press ↑ or ↓ to set the time (hour then minutes) that you want to turn on the projection TV, and press (+).

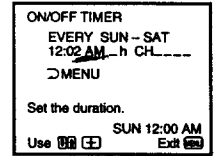
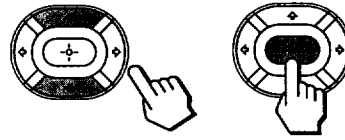

(3) Press ↑ or ↓ to set the time duration, and press (+).

Each time you press ↑, the time duration increases by one hour up to a maximum of six hours.

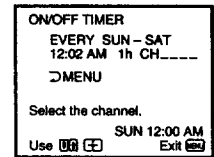
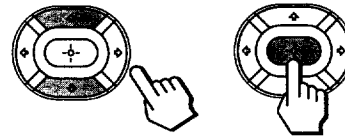

(4) Press ↑ or ↓ to select the channel, and press (+).

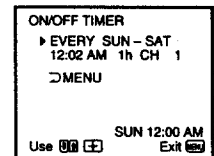
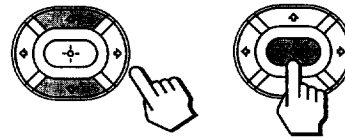

The TIMER indicator on the projection TV lights up.

5 To set the other program, press (+), and repeat step 4.

6 Press MENU to return to the original screen.

One minute before the projection TV turns off, the message "TV will turn off soon." is displayed on the screen.

To cancel the timer

In step 3 or 4, press RESET.

Note

- If you unplug the projection TV or a power interruption occurs, the ON/OFF TIMER setting will be erased. Reset the current time, then set the timer.

Customizing the channel names (CHANNEL CAPTION)

You can add a caption for up to 12 channels. This feature allows you to easily identify which channel you are watching. You can make your own caption.

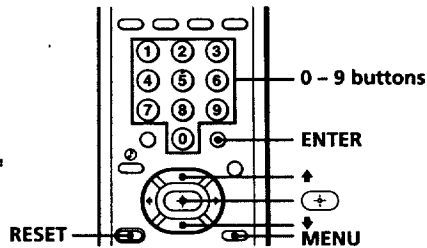

1 Press MENU.

2 Press ↑ or ↓ to select , and press (+).

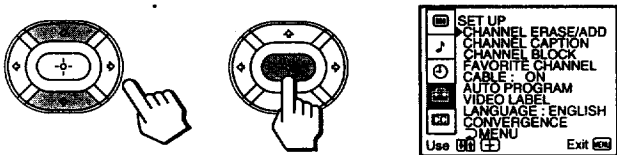

3 Press ↑ or ↓ to select CHANNEL CAPTION, and press (+).

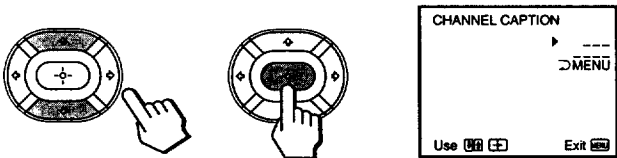

4 Press (+) and press ↑ or ↓ to select the channel that you want to caption, and press (+).

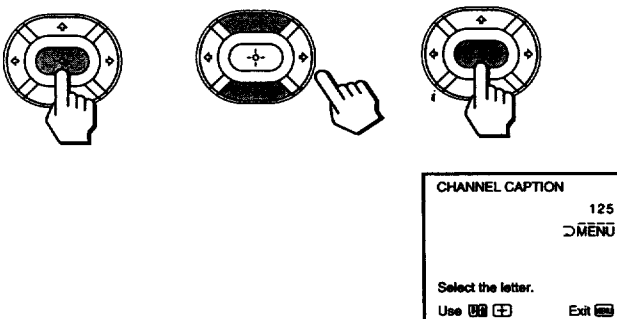

5 Enter the letters (up to four) to caption the channel:

(1) Press ↑ or ↓ to select the first letter.

Each time you press ↑ or ↓, the letter changes as follows:

0...9 ↔ A...Z ↔ &, /, _ (blank space)

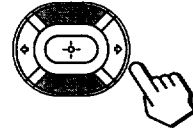

(2) Press (+).

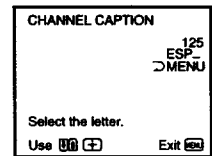

(3) Repeat steps (1) and (2) to select the remaining letters, and press (+).

6 Repeat steps 4 and 5 to caption other channels.

7 Press MENU to return to the original screen.

After you customize the channel, the channel caption appears green.

To erase a caption

In step 5, press RESET.

Notes

- If the CHANNEL CAPTION menu appears in gray, the projection TV is set to a video input, and you cannot select CHANNEL CAPTION. Press TV (black button) so that a channel number appears.
- If more than 90 seconds elapse after you press a button, the menu disappears automatically.
- The channel caption feature is not available for the AUX input.

EN

Blocking out a channel (CHANNEL BLOCK)

The channel block feature allows you to prevent children from watching unsuitable programs. You can block out two channels.

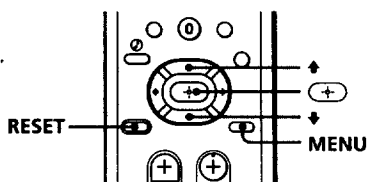

- 1 Press MENU.
- 2 Press ↑ or ↓ to select , and press (+).
- 3 Press ↑ or ↓ to select CHANNEL BLOCK, and press (+).

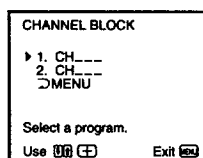
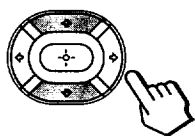

- 4 Press ↑ or ↓ to select program 1 or 2, and press (+).

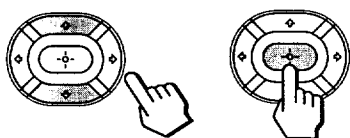

- 5 Press ↑ or ↓ to select the channel which you want to block out, and press (+).

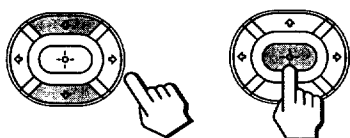

- 6 Press MENU to return to the original screen.

When you select the blocked channel, the message "BLOCKED" appears on the screen.

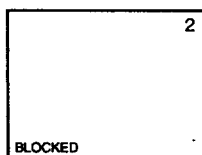

To cancel a CHANNEL BLOCK setting

In step 4 or 5, press RESET.

Note

- Once you use CHANNEL BLOCK, Caption Vision and XDS of the blocked channel and the selected channel output from MONITOR OUT are also blocked out.

Setting your favorite channels (FAVORITE CHANNEL)

The favorite channel feature allows your projection TV to memorize your favorite channels easily.

If you set to AUTO, the last five channels you selected with the 0 – 9 buttons are automatically set as your favorite channels. If you want to input your own selection of channels, set to MANUAL.

Setting your favorite channels

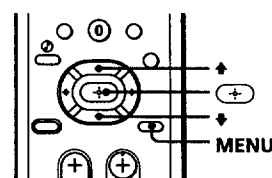

- 1 Press MENU.
- 2 Press ↑ or ↓ to select , and press (+).
- 3 Press ↑ or ↓ to select FAVORITE CHANNEL, and press (+).

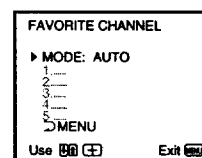
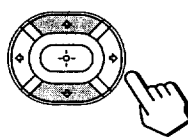

- 4 Press (+) and press ↑ or ↓ to select AUTO or MANUAL, and press (+).

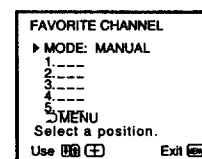
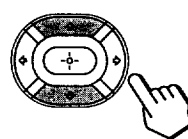

If you select AUTO, skip steps 5 and 6.

The last five channels you selected with the 0 – 9 buttons are automatically set as your favorite channels.

If you select MANUAL, the favorite channel numbers become white, indicating that favorite channels can be entered.

- 5** Press **↑** or **↓** to select a favorite channel number, and press **+**.

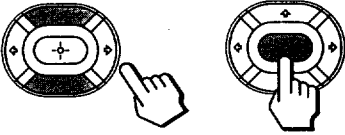

- 6** Press **↑** or **↓** to select the channel that you want to set as your favorite channel, and press **+**.

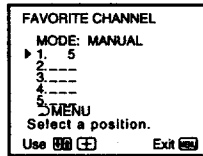
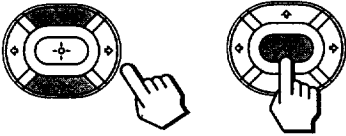

- 7** Press **MENU** to return to the original screen.

Notes

- If the FAVORITE CHANNEL menu appears in gray, the projection TV is set to a video input and you cannot select FAVORITE CHANNEL.
- If more than 90 seconds elapse after you press another button, the menu disappears automatically.
- The favorite channel feature is not available for the AUX input.

Selecting your favorite channel

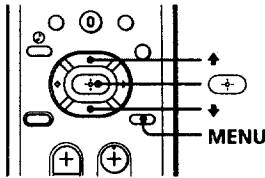

- 1** Press **+**.

The FAVORITE CHANNEL menu appears.

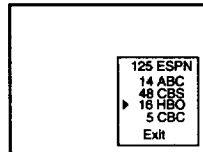

- 2** Press **↑** or **↓** to select the favorite channel you want to watch, and press **+**.

The selected channel appears on the screen.

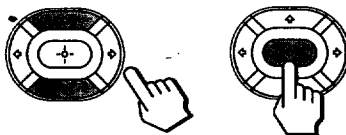

To cancel the FAVORITE CHANNEL menu

Press **↑** or **↓** to select "Exit," and press **+**.

Setting video labels (VIDEO LABEL)

The video label feature allows you to label each input mode so that you can easily identify the connected equipment. For example, you can label VIDEO 1 as VHS.

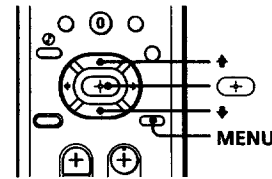

- 1** Press **MENU**.

- 2** Press **↑** or **↓** to select **VIDEO LABEL**, and press **+**.

- 3** Press **↑** or **↓** to select **VIDEO 1**, and press **+**.

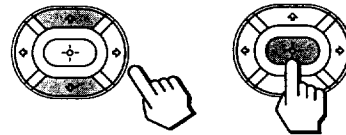

- 4** Press **↑** or **↓** to select the input mode you want to label, and press **+**.

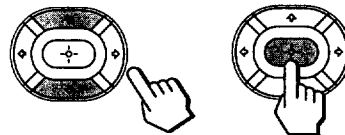

- 5** Press **↑** or **↓** to select the label, and press **+**.

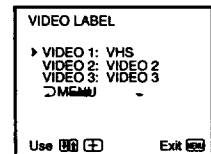
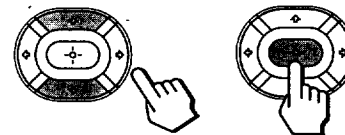

Each time you press \uparrow or \downarrow , the label changes as follows:

VIDEO 1

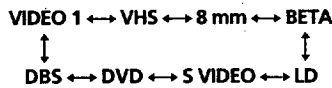

VIDEO 2

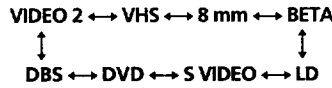

VIDEO 3

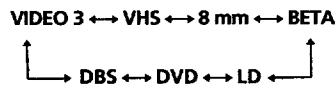

6 Repeat steps 4 and 5 to label other input modes.

Note

- If more than 90 seconds elapse before you press another button, the menu disappears automatically.

Setting Caption Vision (CAPTION VISION)

Some programs are broadcast with Caption Vision. To display Caption Vision, select either CC1, CC2, CC3, CC4, TEXT1, TEXT2, TEXT3, or TEXT4 from the menu. CC1, CC2, CC3, or CC4 shows you on-screen version of the dialogue or sound effects of a program. (The mode should be set to CC1 for most programs.) TEXT1, TEXT2, TEXT3, or TEXT4 shows you on-screen information presented using either half or the whole screen. It is not usually related to the program.

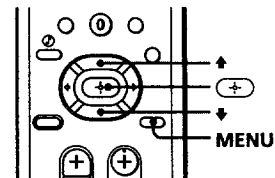

1 Press MENU.

2 Press \uparrow or \downarrow to select CC , and press + .

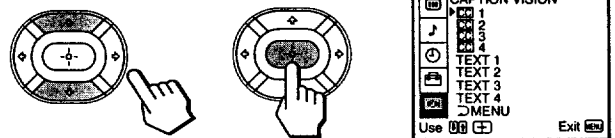

3 Press \uparrow or \downarrow to select the caption type, and press + .

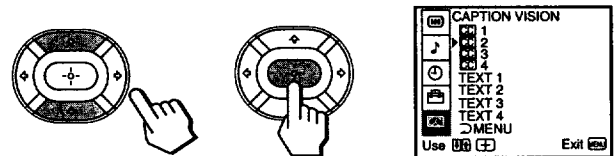

4 Press MENU to return to the original screen.

To display Caption Vision

Press DISPLAY. (See page 20 for details.)

Notes

- Poor reception of TV programs can cause errors in Caption Vision and XDS. Captions may appear with a white box or other errors instead of a certain word.
- XDS, Caption Vision, and the status display cannot be used at the same time.
- For details on XDS, see page 20.

Operating video equipment

You can use the supplied remote control to operate Sony or non-Sony video equipment that has an infrared remote sensor. For this operation, set the manufacturer's code number.

Setting the manufacturer's code

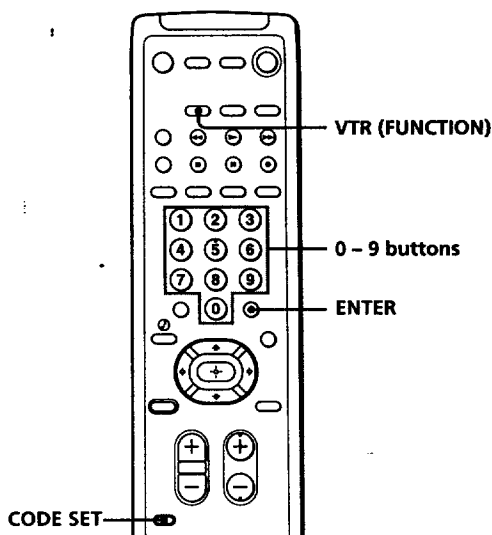

Press the **CODE SET**, **VTR (FUNCTION)**, and **0 - 9** buttons to enter the manufacturer's code number (see the chart on page 35-36), then press **ENTER**.

For example, to operate a Sony 8 mm VCR, press **CODE SET**, **VTR (FUNCTION)**, **3**, **0**, **2**, and **ENTER**.

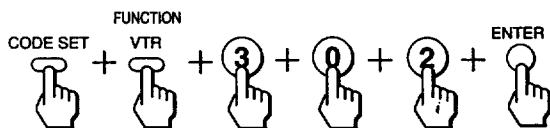

VCR manufacturer code numbers

Manufacturer	Code number
Sony	301, 302, 303
Aiwa	338
Audio Dynamic	314, 337
Bell & Howell (M. Wards)	330, 343
Brocsonic	319
Canon	309, 308
Citizen	332
Craig	315, 302, 332
Curtis Mathis	304, 338, 309
Daewoo	341, 312, 309
DBX	314, 336, 337
Dimensia	304
Emerson	319, 320, 316, 317, 318
Fisher	330, 334, 335, 333
Funai	338
General Electric	329, 304, 309
Goldstar	332
Hitachi	306, 304, 305
Instant Replay	309, 308
JC Penny	309, 305, 304, 330, 314, 336, 337
JVC	314, 336, 337
Kenwood	314, 336, 332, 337
LXI (Sears)	332, 305, 333, 334, 330, 335
Magnavox	308, 309
Marantz	314, 336, 337
Marta	332
Memorex	309, 335
Minolta	305, 304
Mitsubishi/MGA	323, 324, 325, 326
Multitech	325, 338, 321
NEC	314, 336, 337
Olympic	309, 308
Panasonic	308, 309, 306, 307
Pentax	305, 304
Philco	308, 309
Philips	308, 309
Pioneer	308
Quasar	308, 309
RCA/PROSCAN	304, 305, 308, 309, 311, 312, 313
Realistic	309, 330, 328, 335, 324, 338
Sansui	314
Singer	315
Samsung	322, 313, 321
Sanyo	330, 335
Scott	312, 313, 321, 335, 323, 324, 325, 326
Sharp	327, 328
Shintom	315
Signature 2000 (M. Wards)	338, 327
Sylvania	308, 309, 338
Symphonic	338
Tashiro	332
Tatung	314, 336, 337
Teac	314, 336, 338, 337
Technics	309, 308
Toshiba	312, 311
Wards	327, 328, 335, 331, 332
Yamaha	330, 314, 336, 337
Zenith	331

EN

MDP manufacturer code numbers

Manufacturer	Code number
Sony	701
Kenwood	707
Magnavox	703
Marantz	702
Mitsubishi	702
Panasonic	704
Philips	703
Pioneer	702
RCA	702
Sanyo	706
Sharp	705
Yamaha	703

Notes

- If more than one code number is listed, try entering them one by one, until you come to the correct code for your equipment.
- In some rare cases, you may not be able to operate your non-Sony video equipment with the supplied remote control. This is because your equipment may use a code that is not included with this remote control. In this case, please use the equipment's own remote control unit.
- The code numbers for Sony equipment are assigned at the factory as follows:

VHS VCR	301 (preset code for the supplied remote control)
8 mm VCR	302
Beta, ED Beta VCRs	303
- Whenever you remove the batteries — to replace them, for example — if too much time is taken, the code number may revert to the factory setting and must be reset.

Operating video equipment

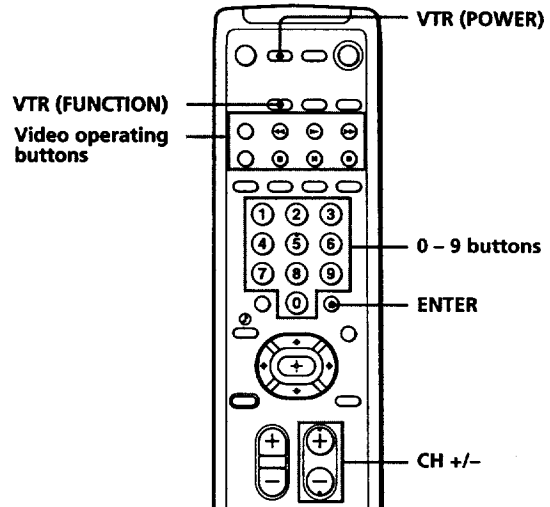

Use the video operating buttons on the remote control to operate the video equipment. Press VTR (FUNCTION) before operating the video equipment.

Operating a VCR	Buttons on the remote control
To turn on or off	Press VTR (POWER).
To select a channel directly	Press the 0-9 buttons.
To change channels	Press CH +/-.
To record	Press ► while pressing ●. First release ►, then release ●.
To play	Press ►.
To stop	Press ■.
To fast forward	Press ►►.
To rewind the tape	Press ◀◀.
To pause	Press .
	To resume normal playback, press again.
To search the picture forward or backward	Press ►► or ◀◀ during playback. To resume normal playback, release the button.
To change input mode	Press TV/VTR.

Operating an MDP	Buttons on the remote control
To turn on or off	Press VTR (POWER).
To play	Press ►.
To stop	Press ■.
To pause	Press .
	To resume normal playback, press again.
To search the picture forward or backward	Keep pressing ►► or ◀◀ during playback. To resume normal playback, release the button.
To search the chapter forward and backward	Press CH +/-.

Note

- If the video equipment does not have a certain function, the corresponding button on this remote control will not operate.

Operating a cable box or DBS receiver

You can program the supplied remote control to operate a cable box or DBS receiver. Follow the procedures below to set the manufacturer's code number in the remote control.

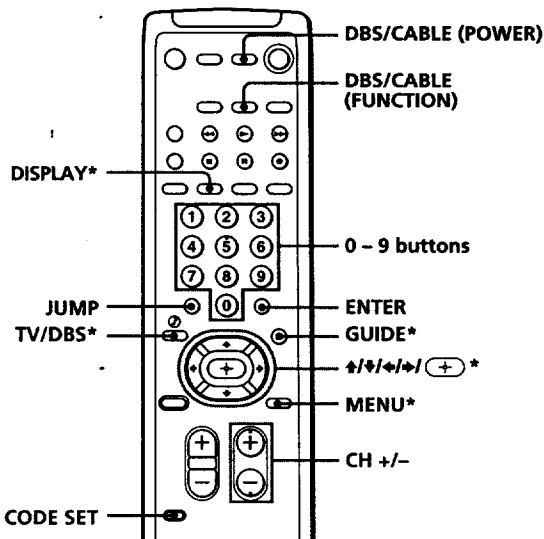

* The TV/DBS, GUIDE, DISPLAY, $\uparrow/\downarrow/\leftarrow/\rightarrow$, and MENU buttons can be used only with a DBS receiver.

1 Turn off the equipment you want to set up, and press DBS/CABLE (FUNCTION).

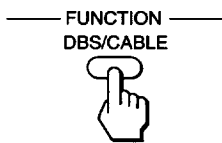

2 Press the CODE SET, DBS/CABLE (FUNCTION), and 0 - 9 buttons to enter the manufacturer's code number (see the chart on the right column), then press ENTER. For example, to program your remote control to operate a Sony DBS receiver, press CODE SET, DBS/CABLE (FUNCTION), 8, 0, 1, and ENTER.

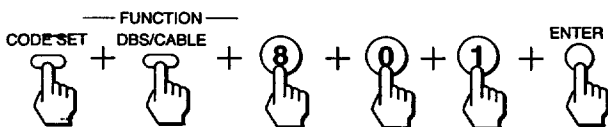

3 Press DBS/CABLE (POWER) to turn on the cable box or DBS receiver.

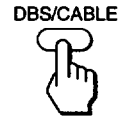

4 Use the cable box/DBS control buttons to check if the code number works.

For example, to operate a cable box or DBS receiver, you can use the DBS/CABLE (POWER), JUMP, CH +/-, 0 - 9 and ENTER buttons.

Note

- If the cable box or DBS receiver does not have a certain function, the corresponding button on this remote control will not operate.

To operate the projection TV

Press TV (FUNCTION). Then use the projection TV control buttons to control the projection TV.

For more details on operating the cable box or DBS receiver

Refer to the operating instructions that come with the equipment.

EN

If the remote control doesn't work

- First, try repeating the setup procedures using the other codes listed for your equipment.

Manufacturer code numbers (cable box)

Manufacturer	Code number
Hamlin/Regal	222, 223, 224, 225, 226
Jerrold/G. I.	201, 202, 203, 204, 205, 206, 207, 208, 218
Oak	227, 228, 229
Panasonic	219, 220, 221
Pioneer	214, 215
Scientific Atlanta	209, 210, 211
Tocom	216, 217
Zenith	212, 213

Manufacturer code numbers (DBS receiver)

Manufacturer	Code number
Sony	801 (preset code for the supplied remote control)
RCA	802

Notes

- If more than one code number is listed, try entering them one by one until you come to the correct code for your equipment.
- If you enter a new code number, the code number you previously entered at that setting is erased.
- In some rare cases, your equipment may use a code that is not provided with this remote control and you may not be able to operate your equipment with the supplied remote control. In this case, use the equipment's own remote control unit.
- Whenever you remove the batteries — to replace them, for example — if too much time is taken, the code numbers may revert to the factory setting and must be reset.

Troubleshooting

If the problem persists after trying the methods below, contact your nearest Sony dealer.

No picture (screen not lit), no sound

- ➔ Make sure the power cord is connected securely.
- ➔ Operate with the buttons on the projection TV.
- ➔ Insert the batteries in the remote control with the correct polarity.
- ➔ Replace the batteries with new ones if they are weak.
- ➔ Check to see if the TV/VIDEO setting is correct: when watching TV, set to TV, and when watching video tapes, set to VIDEO1, 2, or 3.
- ➔ Try another channel. It could be station trouble.
- ➔ Perform AUTO SET UP again using the SETUP button to return to the factory preset condition. (page 14)

Poor or no picture (screen lit), good sound

- ➔ Adjust PICTURE in the VIDEO menu. (page 23)
- ➔ Adjust BRIGHTNESS in the VIDEO menu. (page 23)
- ➔ Adjust convergence. (page 16)
- ➔ Check antenna/cable connections. (page 6)
- ➔ Perform AUTO SET UP again using the SETUP button to return to the factory preset condition. (page 14)
- ➔ Remove objects from the front of the projection TV.

Good picture, no sound

- ➔ Press MUTING so that "MUTING" disappears from the screen. (page 19)
- ➔ Check the MTS setting in the AUDIO menu. (page 27)
- ➔ Make sure SPEAKER is set to ON in the AUDIO menu. (page 27)
- ➔ Perform AUTO SET UP again using the SETUP button to return to the factory preset condition. (page 14)

No color

- ➔ Adjust the COLOR in the VIDEO menu. (page 23)
- ➔ Confirm that black and white program is not being broadcast.
- ➔ Perform AUTO SET UP again using the SETUP button to return to the factory preset condition. (page 14)

Only snow and noise appear on the screen

- ➔ Check the CABLE setting in the SET UP menu. (page 17)
- ➔ Check the antenna/cable connections. (page 6)
- ➔ Make sure the channel is broadcasting programs.
- ➔ Press ANT to change the input mode. (page 20)

Dotted lines or stripes

- ➔ Adjust the antenna.
- ➔ Move the projection TV away from noise sources such as cars, neon signs, and hair-dryers.

Double images or ghosts

- ➔ Use a highly directional outdoor antenna or a cable (when the problem is caused by reflections from nearby mountains or tall buildings).

Cannot operate menu

- ➔ If the item you want to choose appears in gray, you cannot select it. Press TV/VIDEO correctly.
- ➔ Check the CABLE setting in the SET UP menu. (page 17)

Cannot receive upper channels (UHF) when using an antenna

- ➔ Make sure CABLE is OFF in the SET UP menu. (page 17)
- ➔ Use AUTO PROGRAM to add receivable channels that are not presently in projection TV memory. (pages 14, 18)

Cannot receive any channels when using cable TV

- ➔ Make sure CABLE is ON in the SET UP menu. (page 17)
- ➔ Use AUTO PROGRAM to add receivable channels that are not presently in projection TV memory. (pages 14, 18)

Remote control does not operate

- ➔ Batteries could be weak. Replace the batteries. (page 13)
- ➔ Make sure the projection TV's power cord is connected securely to the wall outlet.
- ➔ Press TV (FUNCTION) when operating your projection TV.
- ➔ Are fluorescent lights too close to the projection TV? Move them at least 3-4 feet away from the projection TV.

Cannot gain enough volume when using a cable box

- ➔ Increase the volume at the cable box. Then press TV (FUNCTION) and adjust the projection TV's volume.

The projection TV needs to be cleaned

- ➔ Clean the projection TV with a soft dry cloth. Never use strong solvents such as thinner or benzene, which might damage the finish of the cabinet.

Specifications

- Projection system** 3 picture tubes, 3 lenses, horizontal in-line system
- Picture tube** 7 inch high-brightness monochrome tubes (6.3 raster size), with optical coupling and liquid cooling system
- Projection lenses** High performance, large-diameter hybrid lens F1.1

Screen size (measured diagonally)

KP-41T65	41 inches
KP-48S65	48 inches
KP-53S65	53 inches
KP-61S65	61 inches

- Television system** American TV standards
- Channel coverage** VHF: 2 – 13 / UHF: 14 – 69 / CATV: 1 – 125
- Antenna** 75 ohm external antenna terminal for VHF/UHF

- Inputs/output**
- VIDEO IN 1
VIDEO IN 2 (VIDEO 2 INPUT)
S VIDEO (4-pin mini DIN):
Y: 1 Vp-p, 75-ohms unbalanced, sync negative
C: 0.286 Vp-p (Burst signal) 75 ohms
VIDEO (phono jack): 1 Vp-p, 75-ohms unbalanced, sync negative
AUDIO (phono jacks): 500 mVrms (100% modulation) Impedance : 47 kilohms
- VIDEO IN 3
VIDEO (phono jacks): 1 Vp-p, 75-ohms unbalanced, sync negative
AUDIO (phono jacks): 500 mVrms (100% modulation) Impedance: 47 kilohms

MONITOR OUT

- VIDEO (phono jack): 1 Vp-p, 75-ohms unbalanced, sync negative
AUDIO (phono jacks): 500 mVrms (100% modulation), Impedance: 5 kilohms
AUDIO OUT (phono jacks): 500 mVrms (100% modulation) Impedance: 5 kilohms

- Speaker** Full range speaker 100 mm (3.9 inches) diameter

- Speaker output** 12 W × 2

- Power requirement** 120 V, 60 Hz

- Power consumption** 165 W
Standby mode: 2.5 W

	Dimensions(W/H/D)	Mass
KP-41T65	951 × 1,022 × 602 mm (37 1/2 × 40 1/4 × 23 3/4 inches)	55 kg (121 lbs 4 oz)
KP-48S65	1,106 × 1,337 × 571 mm (43 5/8 × 52 5/8 × 22 1/2 inches)	67 kg (147 lbs 11 oz)
KP-53S65	1,218 × 1,413 × 614 mm (48 × 55 5/8 × 24 1/4 inches)	69 kg (152 lbs 1 oz)
KP-61S65	1,338 × 1,506 × 642 mm (52 3/4 × 59 3/8 × 25 3/8 inches)	122 kg (268 lbs 15 oz)

EN

Supplied accessories

- Remote control RM-Y136A (1)
Size AA (R6) battery (2)

Optional accessories

- U/V mixer EAC-66
Connecting cables RK-74A, VMC-810S/820S, YC-15V/30V, VMC-720M
Stand SU-41T2 (For KP-41T65)
High-contrast protective screen
SCN-48X2 (For KP-48S65)
SCN-53X2 (For KP-53S65)
SCN-61X2 (For KP-61S65)

Design and specifications are subject to change without notice.

Index to parts and controls

This section briefly describes the buttons and controls on the projection TV and on the Remote control. For more information, refer to the pages next to each description.

Projection TV — Front

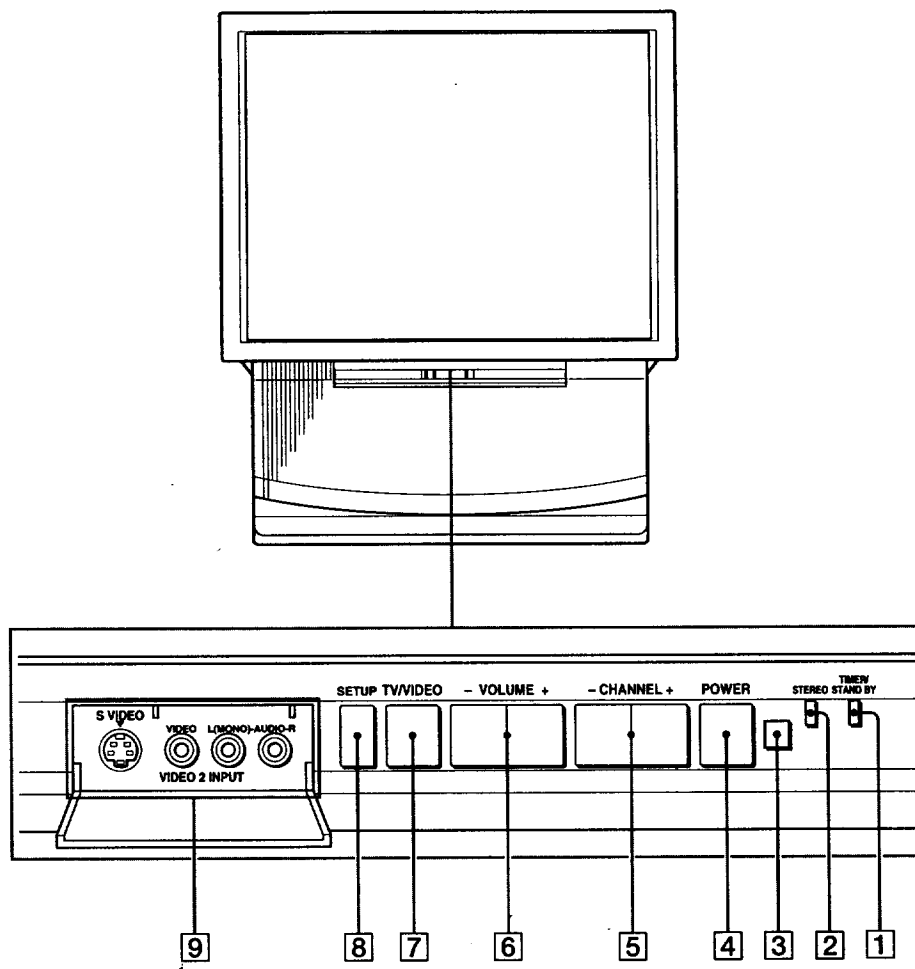

- | | |
|---|--|
| 1 TIMER/STANDBY indicator (pages 19, 30) | 6 VOLUME +/- buttons (page 14) |
| 2 STEREO indicator (page 27) | 7 TV/VIDEO button (page 14, 15) |
| 3 Remote sensor | 8 SETUP button (page 14) |
| 4 POWER switch (page 14) | 9 S VIDEO/VIDEO 2 INPUT (VIDEO/AUDIO L(MONO)/R) jacks (page 10) |
| 5 CHANNEL +/- buttons (page 14) | |

Remote control

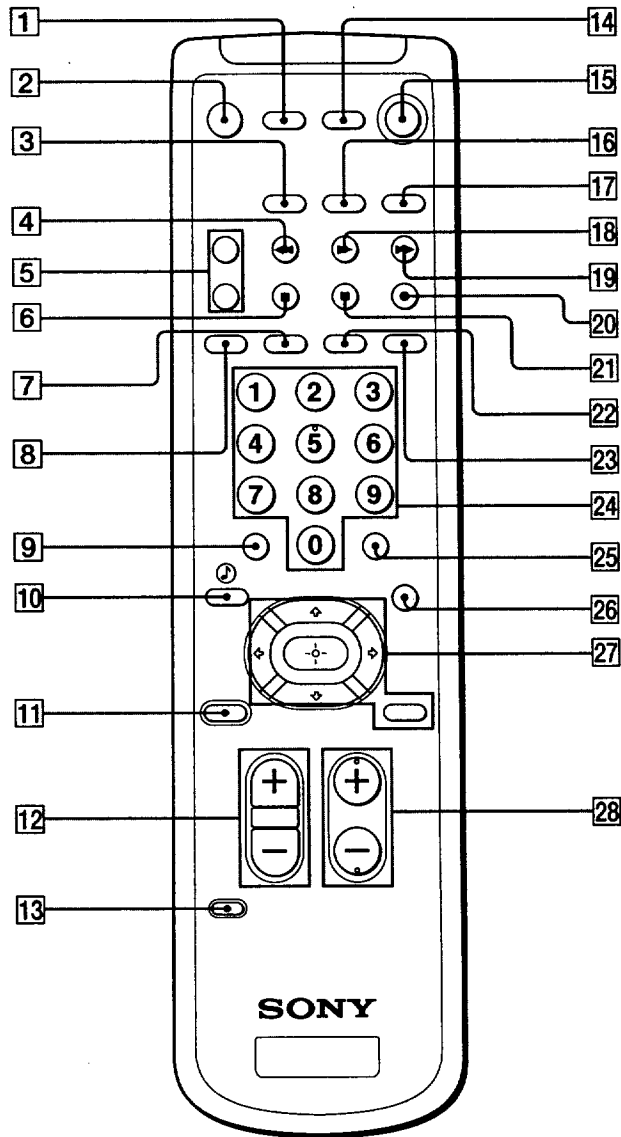

EN

- | | |
|--|--|
| 1 VTR (POWER) switch (page 36) | 17 TV (FUNCTION) button (pages 15, 19) |
| 2 MUTING button (page 19) | 18 SWAP button (page 22) |
| 3 VTR (FUNCTION) button (page 35) | 19 PIP button (page 21) |
| 4 FREEZE button (page 22) | 20 TV/VIDEO button (yellow labelled button) (page 21) |
| 5 TV/VTR CH +/- buttons (Yellow labelled button) (page 21) | 21 AUDIO button (page 21) |
| 6 POSITION button (page 22) | 22 TV/VIDEO button (page 20) |
| 7 DISPLAY button (page 20) | 23 ANT button (page 20) |
| 8 SLEEP button (page 20) | 24 0 - 9 buttons (page 16) |
| 9 JUMP button (page 19) | 25 ENTER button (page 16) |
| 10 FV/DBS \odot button (page 26, 37) | 26 MTS/GUIDE button (page 27, 37) |
| 11 RESET button (page 23) | 27 Menu operation buttons (page 15) |
| 12 VOL (volume) +/- buttons (page 19) | MENU button |
| 13 CODE SET button (page 35) | $\blacktriangle/\blacktriangleleft/\blacktriangledown/\blacktriangleright$ buttons |
| 14 DBS/CABLE (POWER) switch (page 37) | \oplus button |
| 15 TV (POWER) switch (page 19) | 28 CH (channel) +/- buttons (pages 16, 19) |
| 16 DBS/CABLE (FUNCTION) button (page 37) | |

Index

Adjusting
 the convergence 16
 the picture 23
 the sound 25

Antenna 6

Audio effect  26

Audio out 28

Auto program 18

Auto set up 14

Battery 13

Cable box 6

Cable TV 17

Caption Vision 34

Changing the menu language 18

Channel block 32

Channel caption 31

Current time set 29

Daylight saving time 29

DBS 9, 37

DEMO 15

Erase/Add 15

Favorite channel 32

Hookup
 with a DBS receiver 9
 with a VCR 7
 with an antenna 6
 with an audio system 10
 without a VCR 6

Language 18

MTS (Multichannel TV Sound) 27

On/off timer 30

PIP (Picture-in-Picture) 21

Presetting channels 18

Remote control 13

SAP (Second Audio Program) 27

SAVA speaker 12, 28

Setting
 daylight saving time 29
 the clock 29

Sleep timer 20

Speaker 27

STEREO indicator 27

Super woofer mode 28

Surround 26

Surround mode 28

TEXT 34

TIMER/STANDBY indicator 19, 30

Video label 33

Video mode 24

Watching
 TV 19
 video tapes 20

XDS 20

Names of controls

 buttons 15

 button 15

0-9 buttons 16, 19

ANT button 20

AUDIO button 21

AUDIO (VAR/FIX) OUT jacks 12

AUX antenna terminal 6

CHANNEL +/- buttons 14

CH (channel) +/- buttons 16, 19

CODE SET button 35

CONTROL S OUT jack 12

CONVERTER antenna terminal 6

DBS/CABLE (FUNCTION) button 37

DBS/CABLE (POWER) switch 37

DISPLAY button 20

ENTER button 16

FREEZE button 22

JUMP button 19

MENU button 15

MONITOR OUT jacks 11

MTS/GUIDE button 27, 37

MUTING button 19

PIP button 21

POSITION button 22

POWER switch 14

RESET button 23

SETUP button 14

S VIDEO input jack 8

S VIDEO/VIDEO 2 INPUT (VIDEO/AUDIO L (MONO)/R) jacks 10

SLEEP button 20

SWAP button 22

TV/DBS  button 26, 37

TV (FUNCTION) button 15, 19

TV (POWER) switch 19

TV/VIDEO button 14, 15

TV/VIDEO button (yellow labelled button) 21

TV/VTR CH +/- buttons (yellow labelled button) 21

VHF/UHF antenna terminal 6

VIDEO 1 IN jacks 7

VIDEO 3 IN jacks 7

VOLUME +/- buttons 14

VOL (volume) +/- buttons 19

VTR (FUNCTION) button 35

VTR (POWER) switch 36