

AV Control Stereo Receiver

SA-AX920

SA-AX720

Operating Instructions



The photographs show SA-AX920.

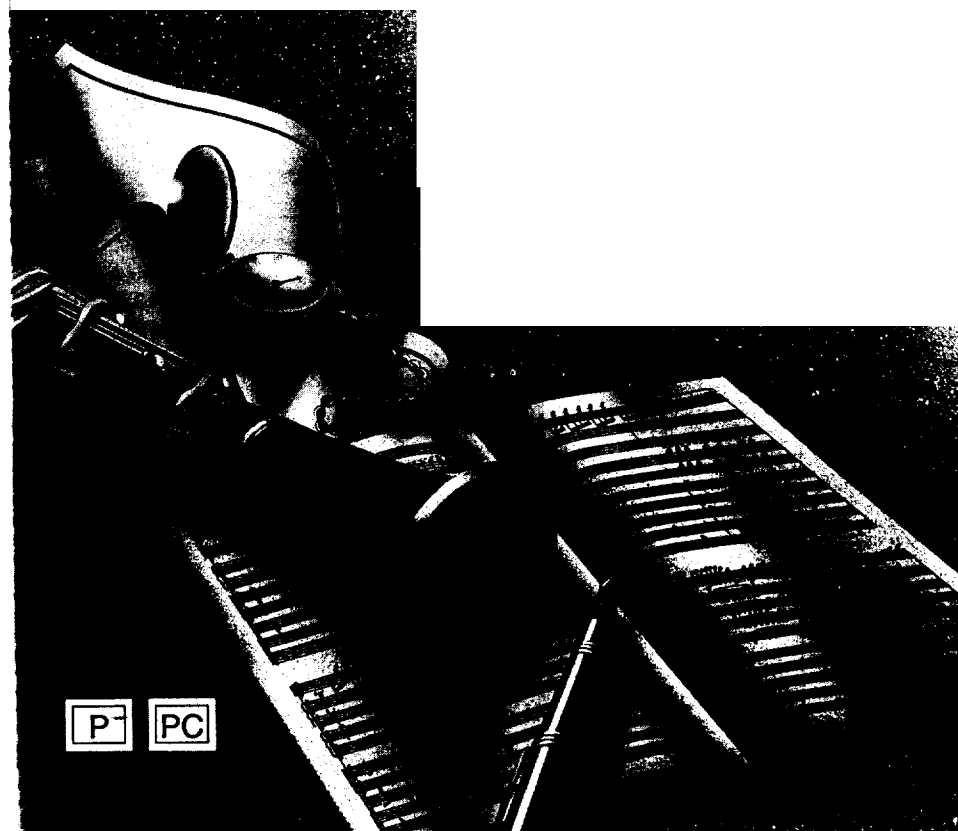

Dear Customer

Thank you for purchasing this Technics product. For optimum performance and safety, please read these instructions carefully.

These operating instructions are applicable to models SA-AX920 and SA-AX720, however, are intended primarily for model SA-AX920.

Table of contents

Precautions	3
Supplied accessories	4
Listening caution	4
Concerning the remote control	5
Front panel controls	6
Equipment connections	7
Antenna connections	10
Speaker connections	12
<hr/>	
Basic operations	16
To adjust the tone quality.....	18
To adjust the sound balance.....	18
To mute the sound level.....	18
To listen through headphones.....	18
To compensate when the volume is low SA-AX920 only	19
When using the VCR 2 terminals (front side) SA-AX920 only	19
Listening to radio broadcasts	20
Sequential tuning.....	20
Direct tuning.....	21
Preset tuning.....	22
Enjoying sound with DOLBY PRO LOGIC	25
Setting the center mode and adjusting speaker output level.....	25
Adjusting the delay time.....	27
Enjoying SURROUND or 3 STEREO.....	28
Enjoying sound with SFC	29
Adjusting field of sound.....	30
Enjoying sound with 6 channel discrete	32
Making a recording	33
Recording on a tape deck.....	33
Recording on a VCR.....	33
About the HELP function	34
<hr/>	
Product service	34
Troubleshooting guide	35
Technical specifications	Back cover

CAUTION

Do not place a tape deck or CD player on top of this unit. Heat radiated from the top of this unit may cause damage to the tape or CD software.

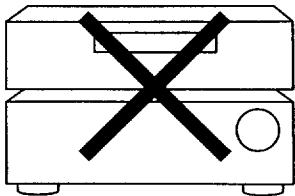

NO

User memo:

DATE OF PURCHASE _____
 DEALER NAME _____
 DEALER ADDRESS _____

 TELEPHONE NUMBER _____

The model number and serial number of this product can be found on either the back or the bottom of the unit. Please note them in the space provided below and keep for future reference.
 MODEL NUMBER
 SERIAL NUMBER

THE FOLLOWING APPLIES ONLY IN THE U.S.A.

CAUTION:
 Any unauthorized changes or modifications to this equipment would void the user's authority to operate this device.

WARNING:
 TO REDUCE THE RISK OF FIRE, ELECTRIC SHOCK OR PRODUCT DAMAGE, DO NOT EXPOSE THIS APPLIANCE TO RAIN, SPLASHING, DRIPPING OR MOISTURE.

CAUTION:
 TO PREVENT ELECTRIC SHOCK MATCH WIDE BLADE OF PLUG TO WIDE SLOT, FULLY INSERT.

CAUTION

RISK OF ELECTRIC SHOCK
DO NOT OPEN

TO REDUCE THE RISK OF ELECTRIC SHOCK, DO NOT REMOVE SCREWS. NO USER-SERVICEABLE PARTS INSIDE. REFER SERVICING TO QUALIFIED SERVICE PERSONNEL.

The lightning flash with arrowhead symbol, within an equilateral triangle, is intended to alert the user to the presence of uninsulated "dangerous voltage" within the product's enclosure that may be of sufficient magnitude to constitute a risk of electric shock to persons.

The exclamation point within an equilateral triangle is intended to alert the user to the presence of important operating and maintenance (servicing) instructions in the literature accompanying the appliance.

Precautions

Before using this unit please read these operating instructions carefully. Take special care to follow the warnings indicated on the unit itself as well as the safety suggestions listed below. Afterwards keep them handy for future reference.

Safety

1. **Power Source** – The unit should be connected to power supply only of the type described in the operating instructions or as marked on the unit.
2. **Polarization** – If the unit is equipped with a polarized AC power plug (a plug having one blade wider than the other), that plug will fit into the AC outlet only one way. This is a safety feature. If you are unable to insert the plug fully into the outlet, try reversing the plug. If the plug should still fail to fit, contact your electrician to replace your obsolete outlet. Do not defeat the safety purpose of the polarized plug.
3. **Power Cord Protection** – AC power supply cords should be routed so that they are not likely to be walked on or pinched by items placed upon or against them. Never take hold of the plug or cord if your hand is wet, and always grasp the plug body when connecting or disconnecting it.
4. **Nonuse Periods** – When the unit is not used, turn the power off. When left unused for a long period of time, the unit should be unplugged from the household AC outlet.

Installation

Environment

1. **Outdoor Antenna Grounding** -- If an outside antenna is connected to the receiver, be sure the antenna system is grounded so as to provide some protection against voltage surges and built-up static charges. Section 810 of the National Electrical Code, ANSI/NFPA No. 70-1990, provides information with respect to proper grounding of the mast and supporting structure, grounding of the lead-in wire to an antenna discharge unit, size of grounding conductors, location of antenna-discharge unit, connection to grounding electrodes, and requirements for the grounding electrode. See figure below.

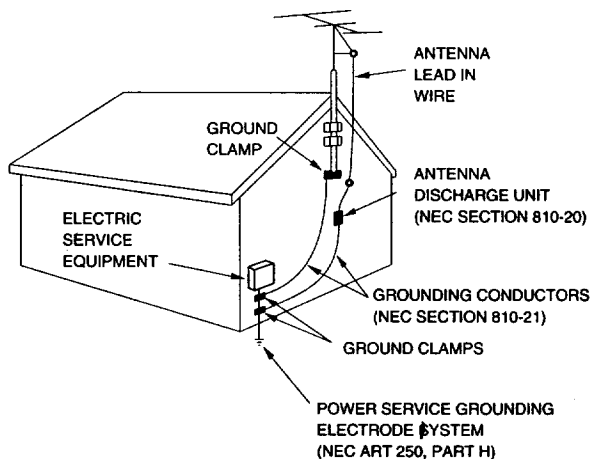

NEC-NATIONAL ELECTRICAL CODE

2. **Water and Moisture** – Do not use this unit near water—for example, near a bathtub, washbowl, swimming pool, or the like. Damp basements should also be avoided.
3. **Heat** – The unit should be situated away from heat sources such as radiators and the like. It also should not be placed in temperatures less than 5°C (41°F) or greater than 35°C (95°F).

Placement

1. **Ventilation** – The unit should be situated so that its location or position does not interfere with its proper ventilation. Allow 10 cm (4") clearance from the rear of the unit.
2. **Foreign Material** – Care should be taken so that objects do not fall into and liquids are not spilled into the unit. Do not subject this unit to excessive smoke, dust, mechanical vibration, or shock.
3. **Magnetism** – The unit should be situated away from equipment or devices that generate strong magnetic fields.
4. **Stacking** -- Do not place heavy objects, other than system components, on top of the unit.
5. **Surface** – Place the unit on a flat, level surface.
6. **Carts and Stands** – The unit should be used only with a cart or stand that is recommended by the manufacturer. The unit and cart combination should be moved with care. Quick stops, excessive force, and uneven surfaces may cause the unit and cart combination to overturn.
7. **Wall or Ceiling Mounting** – The unit should not be mounted to a wall or ceiling, unless specified in this operating instructions.



Maintenance

Clean the cabinet, panel and controls with a soft cloth lightly moistened with mild detergent solution. Do not use any type of abrasive pad, scouring powder or solvent such as alcohol or benzine.

Service

1. **Damage Requiring Service** – The unit should be serviced by qualified service personnel when:
 - (a) The AC power supply cord or the plug has been damaged; or
 - (b) Objects have fallen or liquid has been spilled into the unit; or
 - (c) The unit has been exposed to rain; or
 - (d) The unit does not appear to operate normally or exhibits a marked change in performance; or
 - (e) The unit has been dropped, or the enclosure damaged.
2. **Servicing** – The user should not attempt to service the unit beyond that described in the operating instructions. All other servicing should be referred to an authorized service personnel. (Only for U.S.A.)
Call 1-800-211-7262 for the address of an authorized factory servicenter.

Supplied accessories

- Ⓐ AC power supply cord (SJA172).....1 pc.
- Ⓑ AM loop antenna set (RSA0010)
 - AM loop antenna1 pc.
 - AM loop antenna holder1 pc.
 - Screw1 pc.
- Ⓒ FM indoor antenna (RSA0006).....1 pc.
- Ⓓ Batteries2 pcs.
- Ⓔ Remote control transmitter1 pc.

Use numbers indicated in parentheses when asking for replacement parts.

(Only for U.S.A.)

To order accessories call PASC Accessory Dept. 1-800-211-7262.

Listening caution



Selecting fine audio equipment such as the unit you've just purchased is only the start of your musical enjoyment. Now it's time to consider how you can maximize the fun and excitement your equipment offers. This manufacturer and the Electronic Industries Association's Consumer Electronics Group want you to get the most out of your equipment by playing it at a safe level. One that lets the sound come through loud and clear without annoying blaring or distortion-and, most importantly, without affecting your sensitive hearing.

We recommend you to avoid prolonged exposure to excessive noise.

Sound can be deceiving. Over time your hearing "comfort level" adapts to higher volumes of sound. So what sounds "normal" can actually be loud and harmful to your hearing.

Guard against this by setting your equipment at a safe level BEFORE your hearing adapts.

To establish a safe level:

- Start your volume control at a low setting.
- Slowly increase the sound until you can hear it comfortably and clearly, and without distortion.

Once you have established a comfortable sound level:

- Set the dial and leave it there.

Taking a minute to do this now will help to prevent hearing damage or loss in the future. After all, we want you listening for a lifetime.

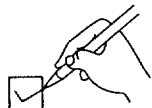

Please check and identify the supplied accessories.

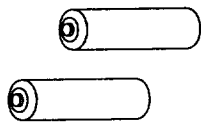
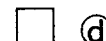
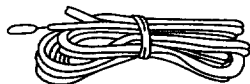
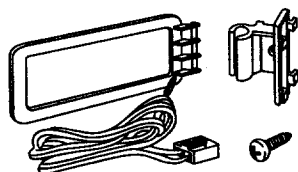
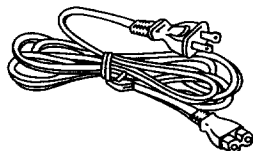

For SA-AX920

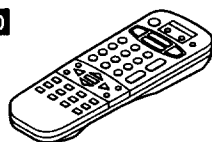

(RAK-SA937MK)

For SA-AX720



(EUR646463)

A

For SA-AX920

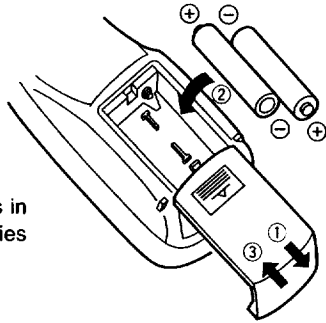

Insert the batteries in the correct polarities (+, -).

For SA-AX720

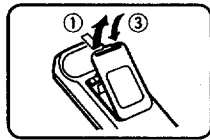

Insert the batteries in the correct polarities (+, -).

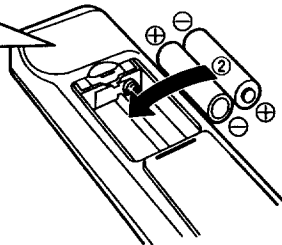

B

Remote control signal sensor

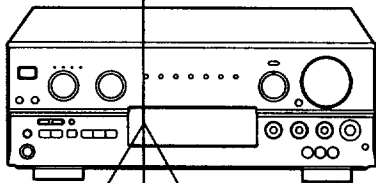

Transmission window

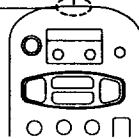

Avoid any obstacles

About 7 meters (23 feet) in front of the signal sensor. (The actual range will depend on the angle at which the remote control is used.)

Battery installation

A

- Thoroughly clean the battery compartment before inserting new batteries.
- Do not mix old and new batteries, or batteries of different types (carbon and alkaline, etc.).
- If you will not use the remote control for a long period of time, remove the batteries and store them in a cool, dark place.
- Do not use rechargeable type batteries.
- Do not attempt to recharge alkaline or carbon batteries.
- Always remove old, weak or worn-out batteries promptly and dispose of them properly.
- Never subject batteries to excessive heat or flame; do not attempt to disassemble them; and be sure they are not short-circuited.
- If the leaking electrolyte comes into contact with skin or clothes, flush with water immediately.

When you need to replace these batteries

Use two R6/LR6, AA, UM-3 batteries.

Method for use

B

Note

Be sure the transmission window and the signal sensor are free from dust. Excessive dust might effect performance.

The operation may not be correct if direct sunlight or other strong light source strikes the signal sensor of this unit. If there is a problem, place the unit away from the light source.

Before use

Front panel controls

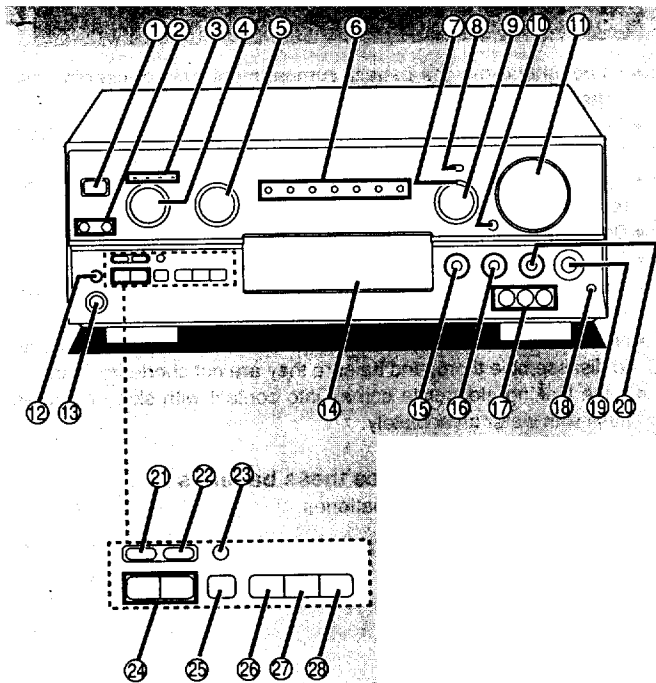

- ① Power "STANDBY /ON" switch (POWER, STANDBY /ON)
Press to switch the unit from on to standby mode or vice versa. In standby mode, the unit is still consuming a small amount of power.
- ② Speaker select buttons (SPEAKERS A, B)
- ③ Dolby Pro Logic mode/SFC indicator
- ④ Dolby Pro Logic mode/SFC selector
- ⑤ SFC mode selector (MODE)
- ⑥ Input indicator
- ⑦ DVD 6ch input indicator
- ⑧ DVD 6ch input select button (DVD 6CH INPUT)
- ⑨ Input selector (INPUT SELECTOR)
- ⑩ Muting button (MUTING)
- ⑪ Volume control (VOLUME)
- ⑫ Help/reset button (-HELP -RESET)
- ⑬ Headphones jack (PHONES)
- ⑭ Display
- ⑮ Bass control (BASS)
- ⑯ Treble control (TREBLE)
- ⑰ **SA-AX920 only**
VCR 2 input terminals (VCR 2)
- ⑱ **SA-AX920 only**
VCR 2, TV/DSS input select button
(VCR 2, TV/DSS)
- ⑲ **SA-AX920 only**
Subwoofer level control (SUBWOOFER LEVEL)
- ⑳ Balance control (BALANCE)
- ㉑ Delay time adjust button (DELAY TIME)
- ㉒ Center mode select button (CENTER MODE)
- ㉓ **SA-AX920 only**
Loudness ON/OFF button (LOUDNESS)
- ㉔ Tuning buttons (TUNING)
- ㉕ Radio station presetting button (PRESET)
- ㉖ Band select button (BAND)
- ㉗ FM mode select button (FM MODE)
- ㉘ Memory button (MEMORY)

Equipment connections

Make sure that the power supply for all components has been turned off before making any connections.

To connect equipment, refer to the appropriate operating instructions.

Note

Do not place books, etc., on the top of this unit or block the heat radiation vents in any way.

Connecting audio equipment

Stereo connection cable (not included)

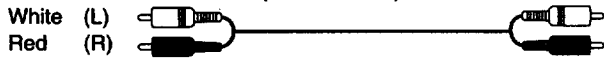

CD changer (or CD player)
(not included)

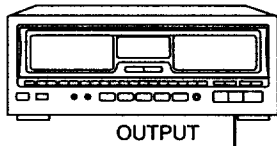

OUTPUT

"SWITCHED" AC outlets

Power to the outlet is controlled by the power switch of this unit. Audio equipment rated up to TOTAL 80 W can be connected here.

For SA-AX720

There is only one AC outlet.

The cooling fan operates at high power output levels only.

Only for turntable with ground terminal

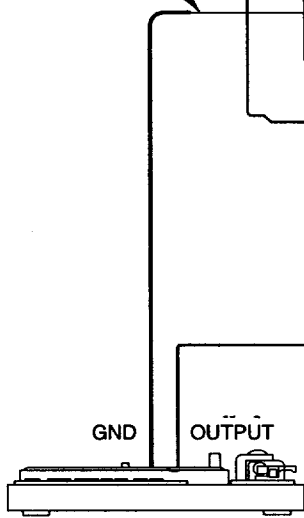

Turntable (not included)

PLAY (OUT) REC (IN)

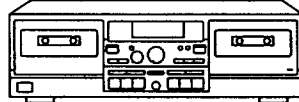

Tape deck (not included)

AC INL



Household AC outlet
(AC 120 V/60 Hz)

AC power supply cord
(included)

Connect this cord only after all other cables and cords are connected.

Connecting video equipment

Stereo connection cable (not included)



Video connection cable (not included)



Laser disc player (not included)

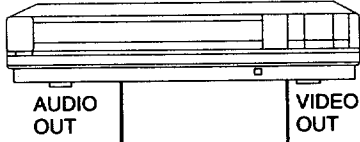

TV (not included)

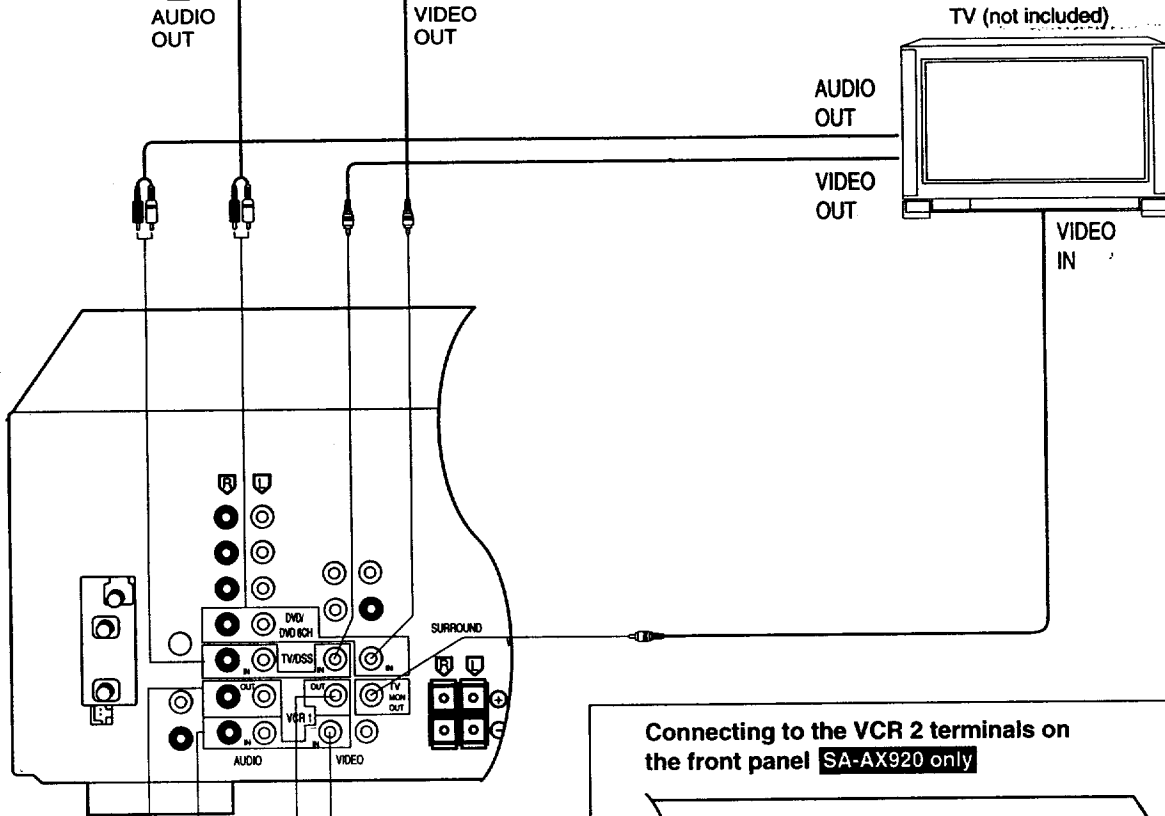
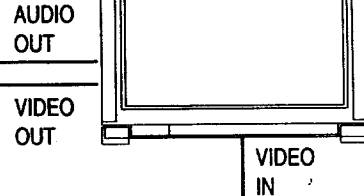

AUDIO IN AUDIO OUT VIDEO IN VIDEO OUT

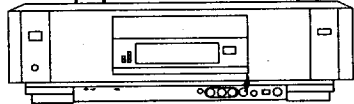

VCR (not included)

Connecting to the VCR 2 terminals on the front panel SA-AX920 only

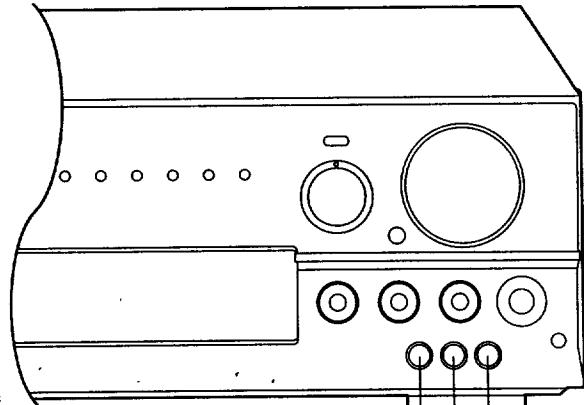

(VIDEO)(L) (R)

Camcorder, etc. (not included)

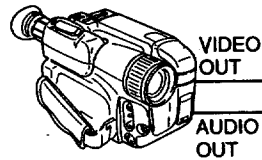

For SA-AX720

The "VCR 1" terminals shown in the illustration corresponds respectively to the "VCR" terminals on SA-AX720.

Before use

Connecting a DVD player

Stereo connecting cable (not included)



Monaural connection cable (not included)



Video connection cable (not included)

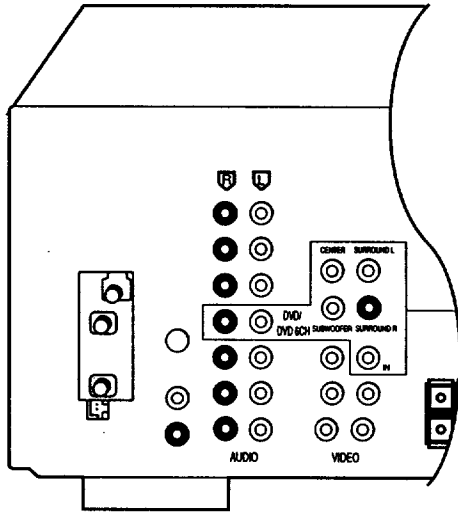

Connecting a DVD player with 6 channel discrete output

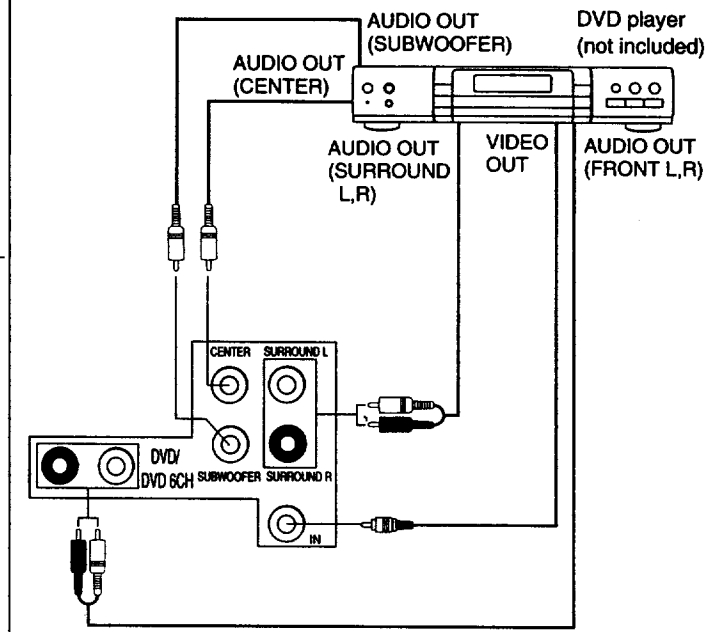

Connecting a DVD player with 2 channel output

DVD player (not included)

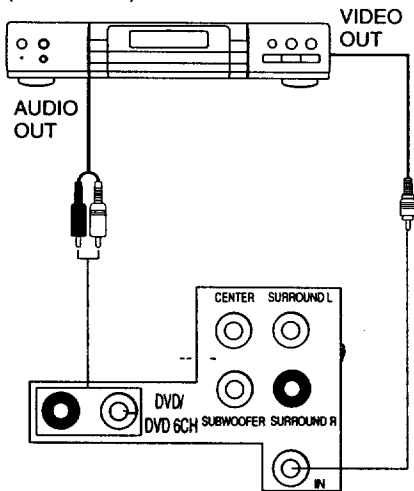

You can enjoy 6 channel discrete sound by making the below connections.

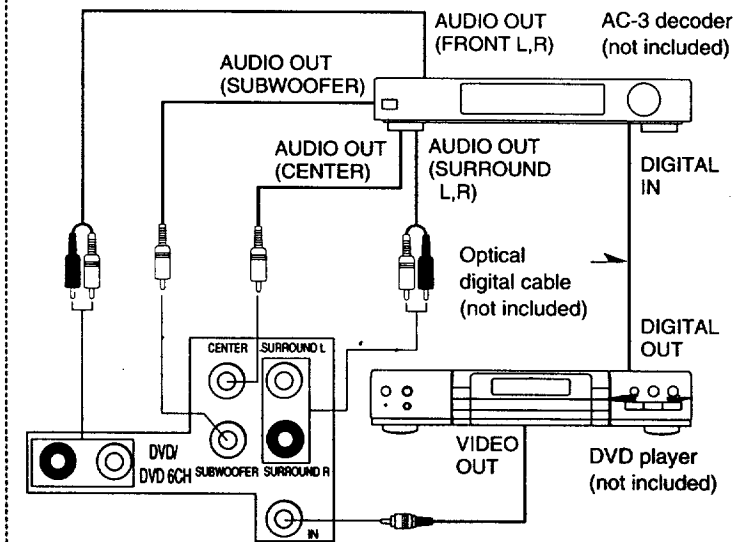

Before use

Antenna connections

FM indoor antenna (included) **A**

This antenna is normally sufficient for reception of FM broadcasts.
Attach to a wall (using tape) facing in the direction of best reception.

For best reception
An FM outdoor antenna is recommended.

AM loop antenna (included) **B**

This antenna is normally sufficient for reception of AM broadcasts.

Fit the AM loop antenna holder (included) onto the rear panel of this unit and then attach the AM loop antenna to the AM loop antenna holder (facing in the direction of best reception).

Pay attention to the following points when mounting the antenna.

- Do not mount it close to power cords, speaker wires or metal surfaces (Doing so will result in noise).
- Do not mount it close to a tape deck. When the tape deck is being used, chirping or beeping sounds may result.

When mounting the antenna to a column, a wall or rack **C**

Mount the antenna so that the hinge is vertical.

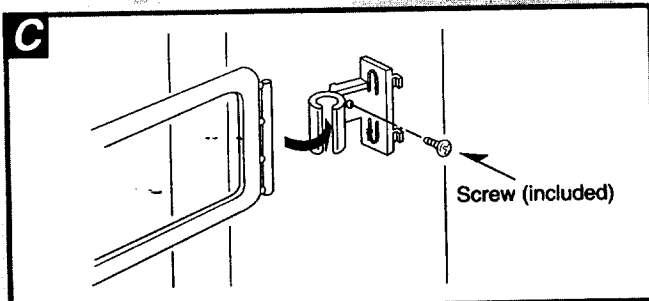
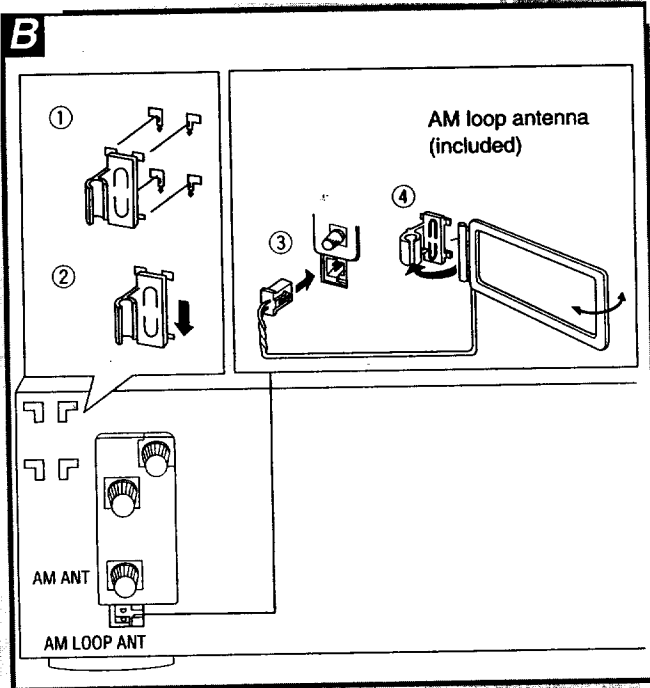
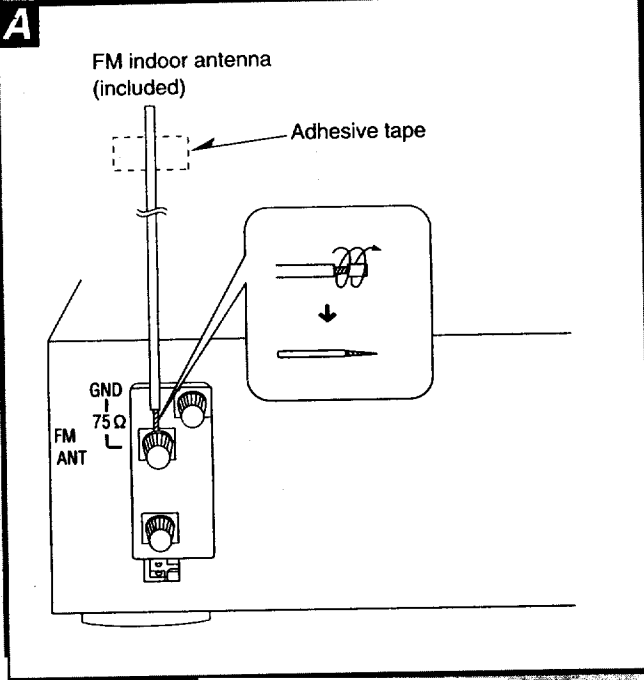

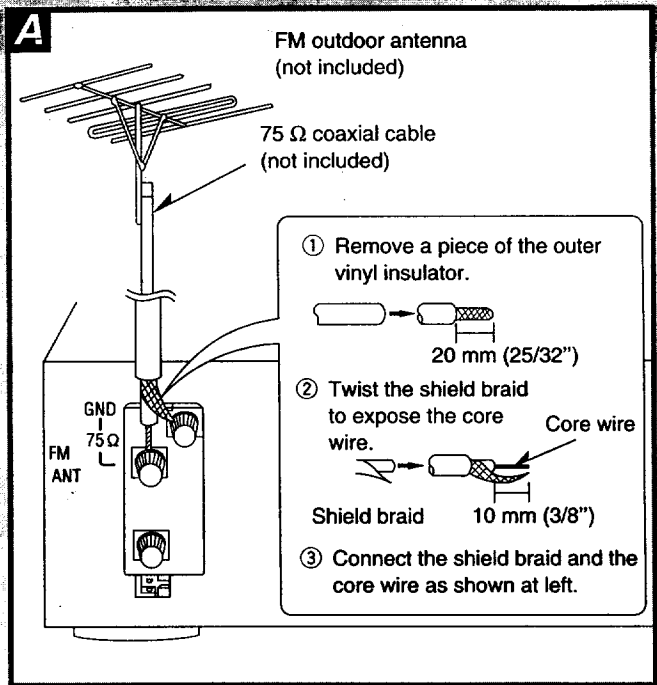

FM outdoor antenna (not included) **A**

An outdoor antenna should be used when using this unit in mountainous areas or in spaces enclosed by reinforced concrete where the FM indoor antenna (included) does not provide satisfactory reception. Disconnect the FM indoor antenna if an FM outdoor antenna is installed.

Note
An outdoor antenna should be installed by a qualified technician only.

AM outdoor antenna (not included) **B**

An outdoor antenna should be used when using this unit in mountainous areas or in spaces enclosed by reinforced concrete where the AM loop antenna (included) does not provide satisfactory reception.

Stretch 5–12 m (16–40 ft.) of vinyl-covered wire horizontally across a window frame or other convenient location, keeping it as high as possible from the ground.

When the unit is not in use, disconnect the outdoor antenna to prevent possible damage that may be caused by lightning. Never use an outdoor antenna during an electrical storm.

Note
Be sure to connect the AM loop antenna even when an outdoor antenna is used.

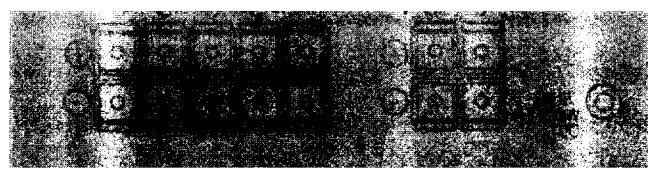
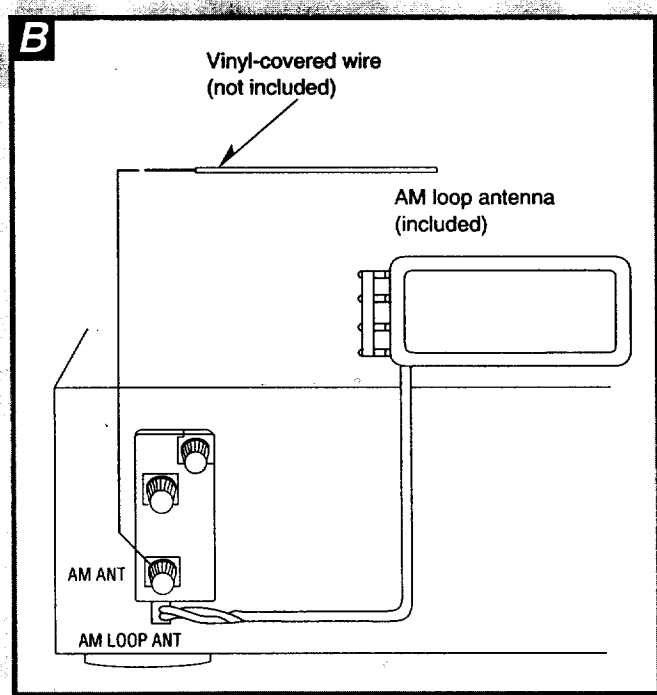

Before use

Placement of speakers

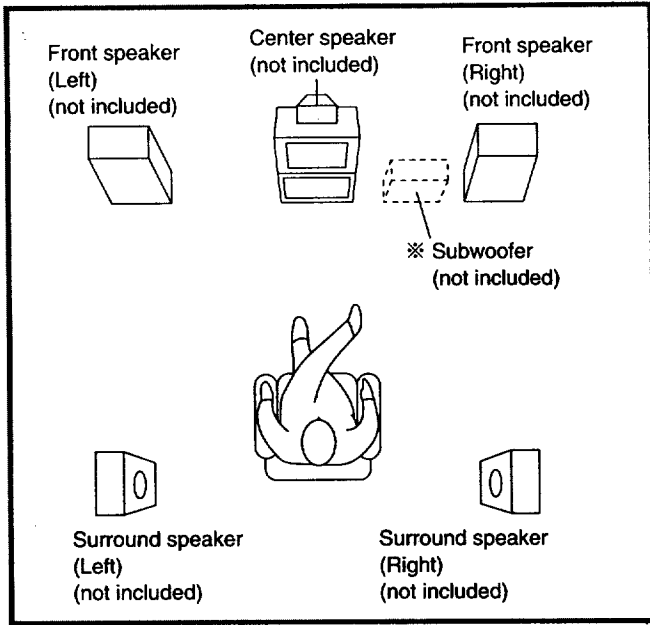

For front speakers

Place the front left/right speakers at both the left and right sides of the TV at seated ear height so that there is good coherency between the picture and sound.

For center speaker

Place the center speaker underneath or above the center of the TV. Aim the speaker such that it is pointed at the seating area.

For surround speakers

Place the surround speakers on the side of or slightly behind the listener, and about one meter higher than ear level.

For subwoofer

The subwoofer can be placed in any position as long as it is at a reasonable distance from the TV.

Note that some experimentation in placement of the subwoofer can yield the smoothest low frequency performance. Placement near a corner can increase the apparent output level, but can result in unnatural bass.

Connecting speakers

SA-AX920

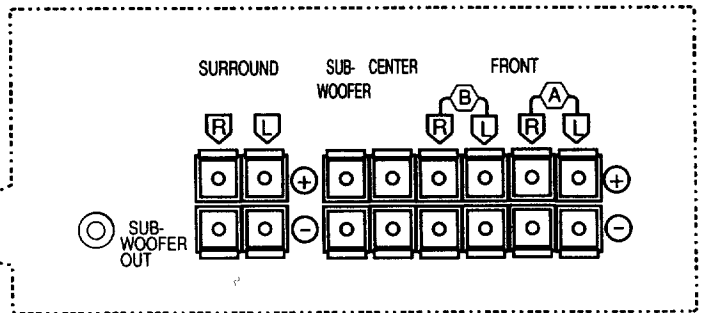
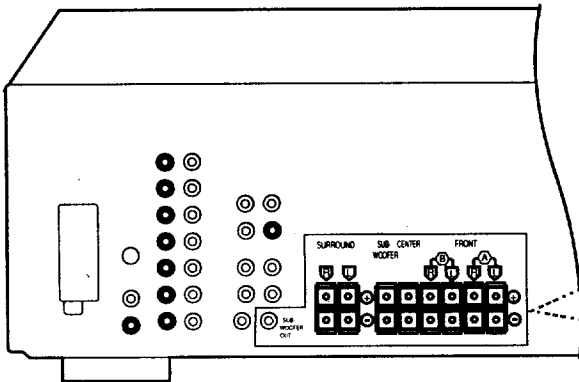

SA-AX720

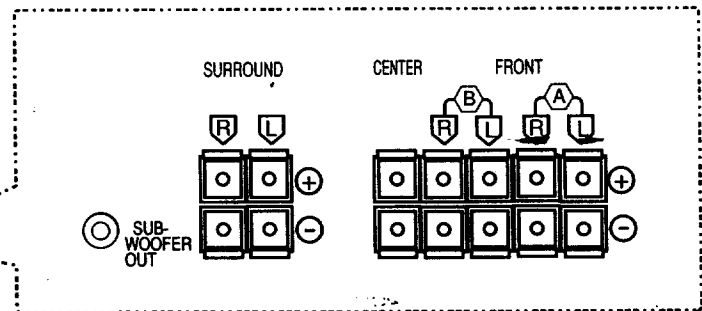
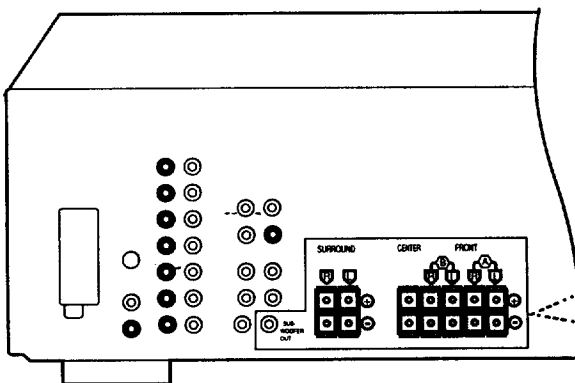

Before use

Note

Other connections are possible depending on the speaker system you have. For details, see the operating instructions that came with your speaker system.

Speaker cable
(not included)



Connecting the speaker cable

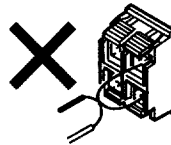
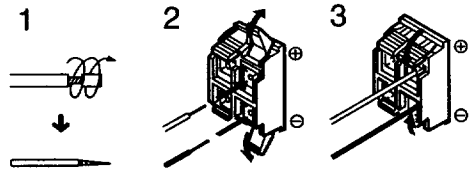

Note

To prevent damage to circuitry, never short-circuit positive (+) and negative (-) speaker wires.

Front speakers

To connect to the "A" terminals

Front speaker
(Right)
(not included)

Front speaker
(Left)
(not included)

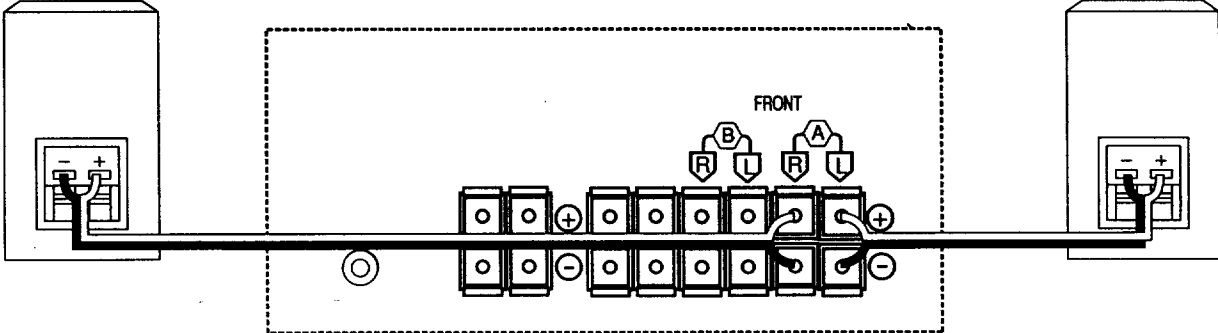

To connect to the "B" terminals

For connection to a second pair of speakers.

Front speaker
(Right)
(not included)

Front speaker
(Left)
(not included)

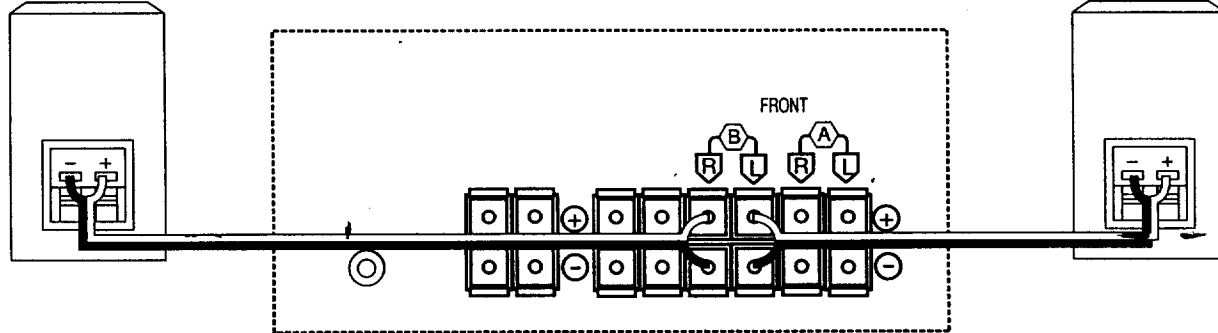

Speaker impedance:

For SA-AX920

A or B: 4-8 Ω
A and B: 8 Ω

For SA-AX720

A or B: 8 Ω
A and B: 8 Ω

Surround speakers

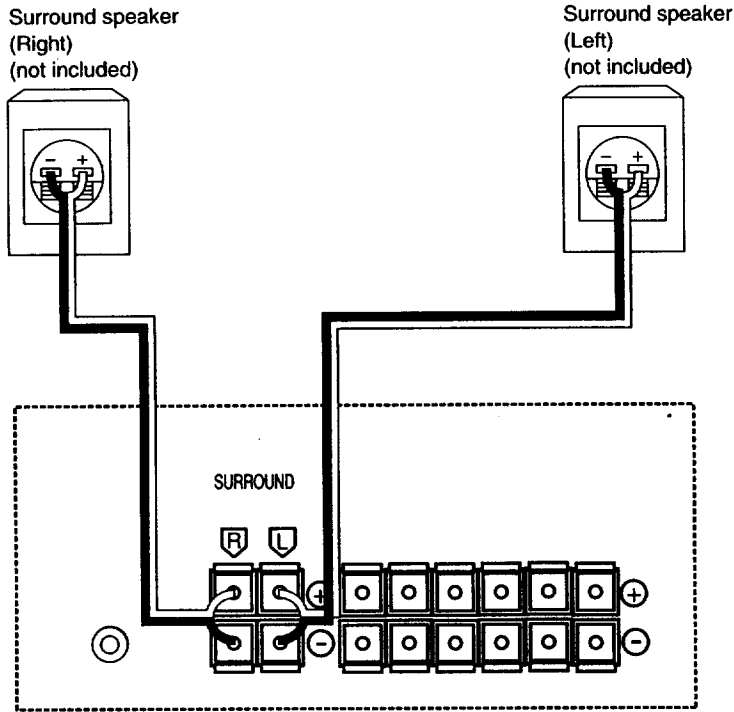

Note

1. Before sound can be heard, both surround speakers must be connected.
2. Do not connect the surround speakers to the front speaker terminals. The surround speakers may be damaged if connected to the front terminals.

Speaker impedance: 8 Ω

Center speaker

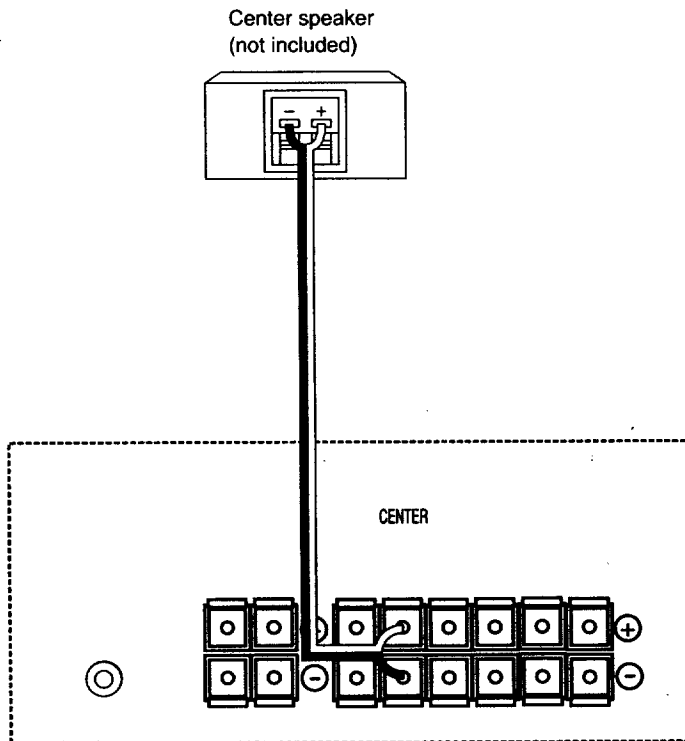

Speaker impedance: 8 Ω

Before use

Subwoofer

To connect a subwoofer which has a built-in amplifier

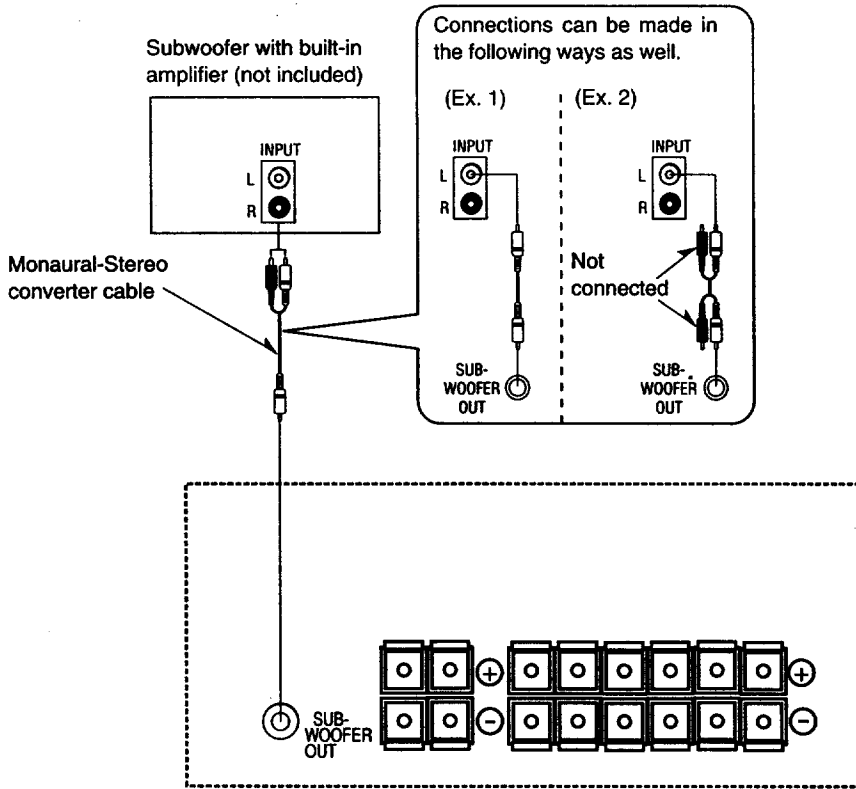

To connect a subwoofer which does not have a built-in amplifier **SA-AX920 only**

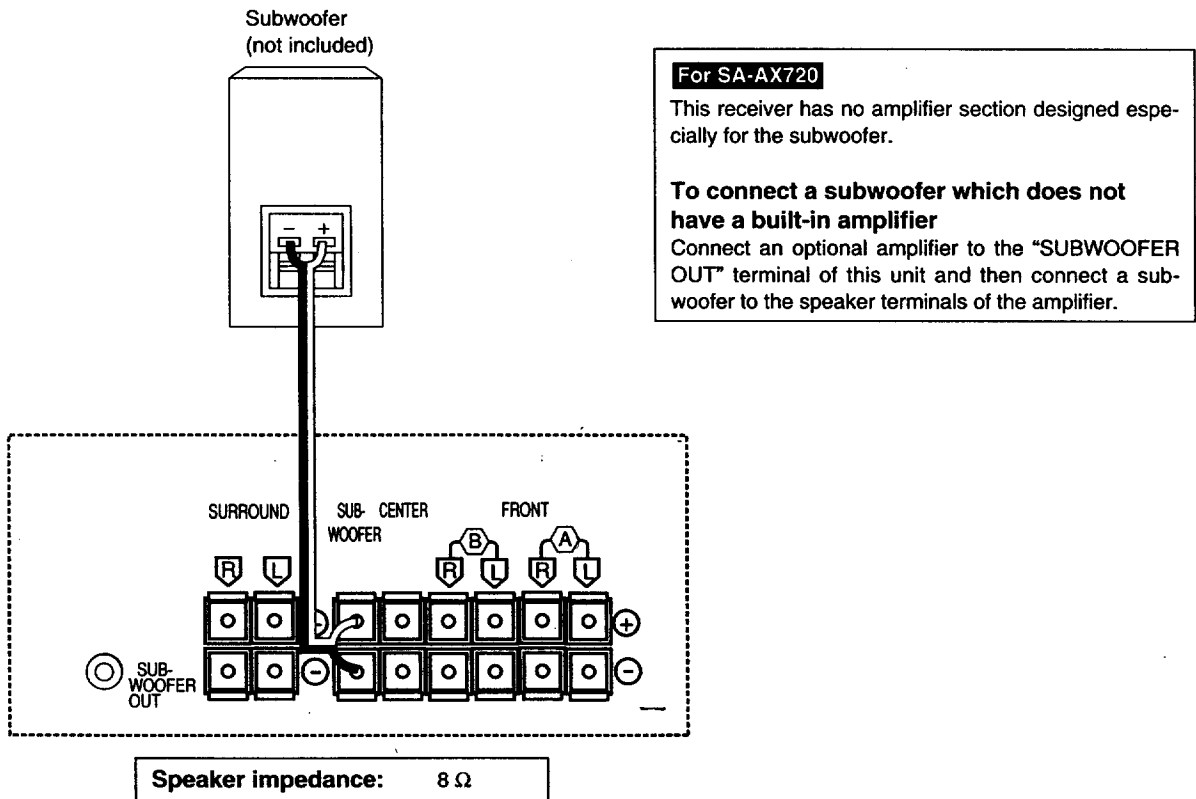

Before operation, set VOLUME to the "MIN" position.

- 1** Press **POWER**.
- 2** Press **A** and/or **B** to select the speaker system(s) to be used.

A and B refer to the speaker terminals at the rear of the unit.

If the button is pressed once more, the indicator will switch off and no sound will be heard from the speakers.

- 3** Turn **INPUT SELECTOR** to select and start the desired source.

(Refer to the appropriate operating instructions for details.)

The indicator which corresponds to the selected input source will illuminate.

VCR 1: To watch video tapes (VCR 1)

TV/DSS/VCR 2: To watch TV, DSS or video tapes (VCR 2)

DVD: To watch DVD

TAPE: To listen to cassette tapes

CD: To listen to compact discs

TUNER: To listen to radio broadcasts

PHONO: To listen to phono discs

For SA-AX720

The "VCR 1" and "TV/DSS/VCR 2" selectors correspond respectively to the "VCR" and "TV/DSS" selectors.

If a Dolby Pro Logic or SFC mode has been selected

After displaying the selected source, the display will then change to show the Dolby Pro Logic or SFC mode.

If the source chosen was TUNER then the display will change again to show the frequency.

The indicator (Ⓜ) which corresponds to the selected mode will light up.

Note

To watch a video (or DVD) or the TV, set the TV to either the TV mode or VIDEO mode as indicated below.

- **To enjoy videos (or DVD)**

Set it to VIDEO mode.

- **To watch TV**

Set it to TV mode.

For your reference

If you are using VCR and you select TAPE, CD, TUNER, or PHONO, the picture will remain on the screen.

- 4** Turn **VOLUME** to adjust the volume level.

SA-AX920 only

If using a subwoofer, adjust its volume with SUBWOOFER LEVEL.

If the subwoofer isn't being used, be sure to set SUBWOOFER LEVEL to MIN.

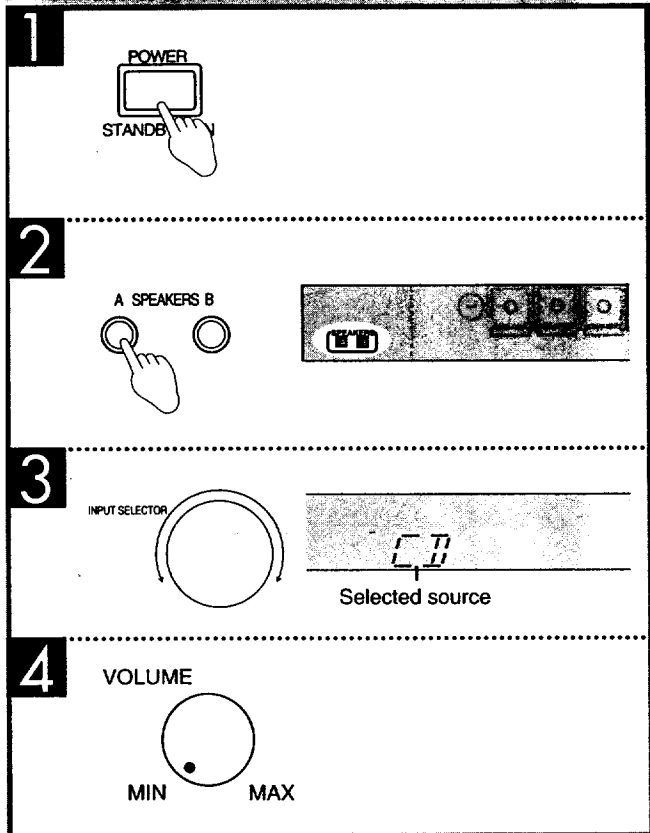
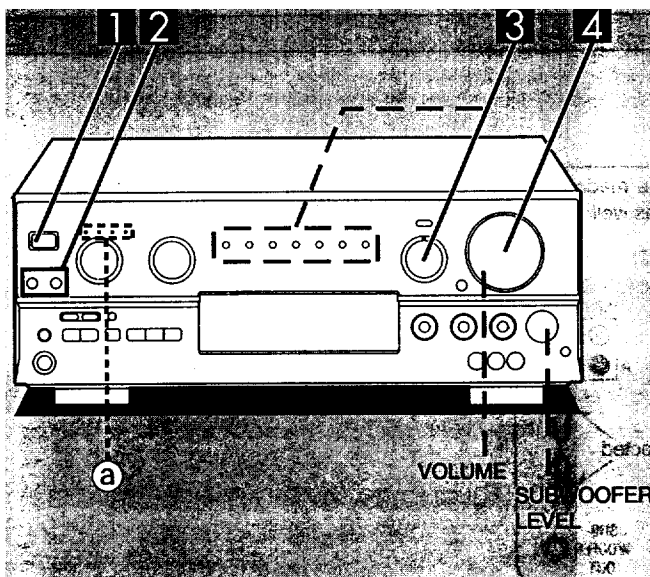

When using speakers under 8 Ω **A**

Press A or B until LOW IMP lights up on the display.

If even one of the speakers being used has an impedance under 8 Ω, press and hold down either button A or button B for 4 seconds or more to set the impedance on the main unit to LOW.

(Press and hold down once again for 4 seconds or more to turn it off.)

Note that When this indicator is illuminated, speakers A and B cannot both be used at the same time.

To change a speaker:

e.g. To use speaker B press A (the **A** indicator goes out), and then press B to activate speaker B.

After listening is finished

Be sure to reduce the volume level, and switch the power to the standby condition by pressing POWER.

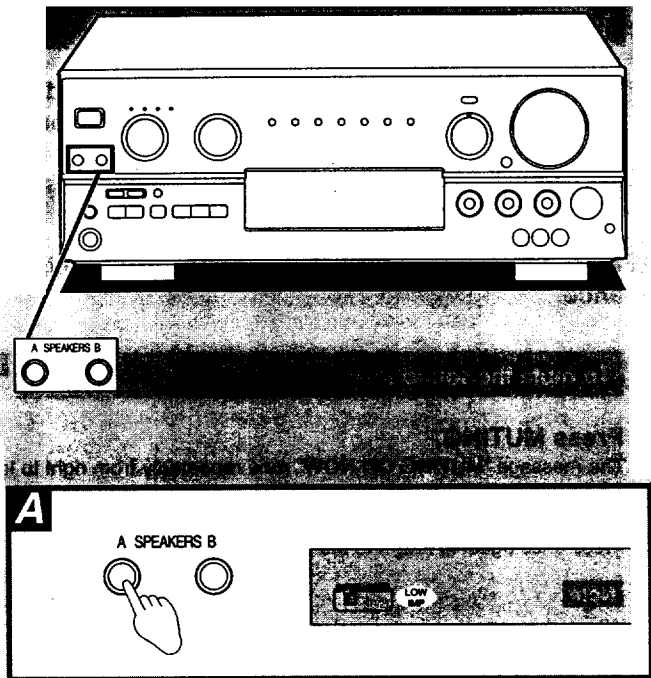

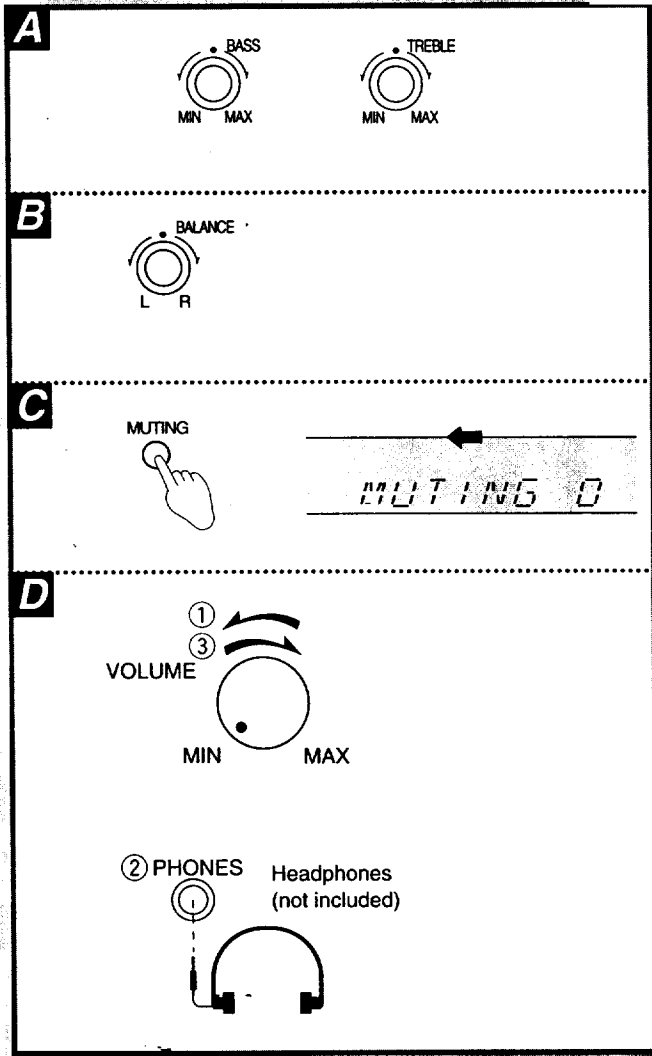
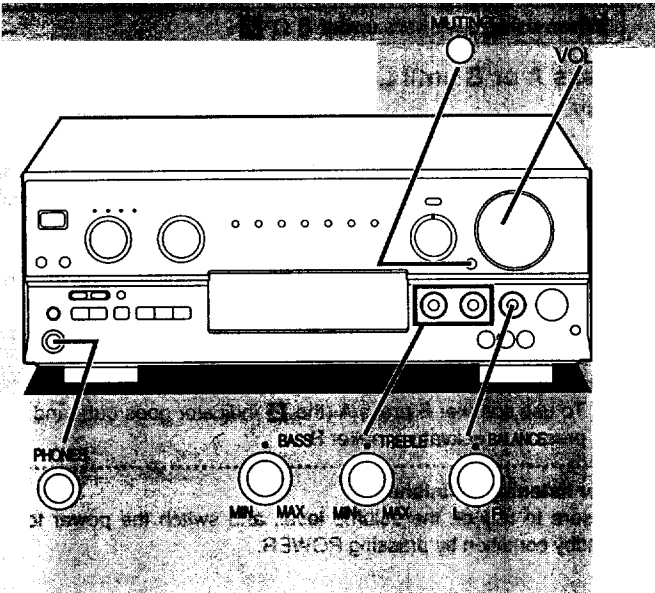

To adjust the tone quality A

Turn **BASS** to adjust the low frequency sound.
Turn **TREBLE** to adjust the high frequency sound.

To adjust the sound balance B

Turn **BALANCE** to adjust the left/right sound balance.

To mute the sound level C

Press MUTING.

The message "MUTING ON NOW" runs repeatedly from right to left across the display as long as the muting function is on.

Press once again to return to the previous volume level.

Note

When the receiver is turned off, the muting operation will be automatically cancelled.

To listen through headphones D

- ① Use **VOLUME** to reduce the volume level.
- ② Connect the headphones.
Plug type: 6.3 mm (1/4 in.) stereo
- ③ Use **VOLUME** to adjust the volume level.

If you do not want sound from the speakers, press **SPEAKERS** button(s) and check the speaker indicator(s) goes out.

For SA-AX720

If a subwoofer is connected to your system, turn off the power to it (or the subwoofer amp you are using) or lower the volume to the minimum level.

For SA-AX920

If a subwoofer is connected to your system, silence it by turning the **SUBWOOFER LEVEL** control on the receiver to **MIN**.

Note

Avoid listening for prolonged periods of time to prevent hearing damage.

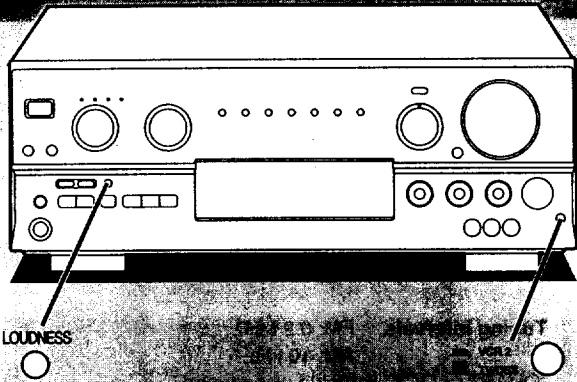

To compensate when the volume is low A
SA-AX920 only

This button balances low volume sounds by boosting bass sound pressure.

Press LOUDNESS.

The message "ON" will appear on the display for 2 seconds. When "ON", "▶" will light up in the display.

To return to the previous condition, press once again.

The message "OFF" will appear on the display for 2 seconds, then "▶" turns off.

When using the VCR 2 terminals (front side) B
SA-AX920 only

This button can be used only when TV/DSS/VCR 2 is selected as the input source.

The VCR 2, TV/DSS input select button works for both TV/DSS input and input from the source connected to the front side "VCR 2" terminals. (See page 8.)

Set "■ VCR 2" or "■ TV/DSS" position.

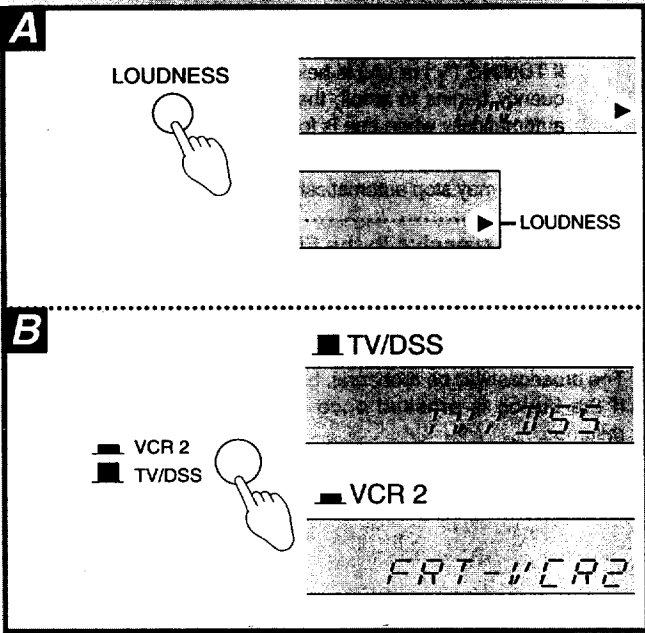

Sequential tuning

Use the tuning buttons to tune-in radio stations.

- 1** Turn **INPUT SELECTOR** to select **TUNER**.
- 2** Press **BAND** to select "FM" or "AM".
- 3** Press **TUNING** (∨) or (∧) to tune to the desired frequency.

Tuning intervals FM: 0.2 MHz
 AM: 10 kHz

"QUARTZ LOCK" lights up when tuned.

"STEREO" lights up when an FM stereo broadcast is received.

To make an automatic search for stations

If **TUNING** (∨) or (∧) is held down for an instant until the frequency begins to scroll, the broadcast stations are tuned in automatically when one is found.

Note

Tuning may stop automatically if any jamming is encountered.

If noise is excessive in the FM stereo mode

Press **FM MODE**.

(The "STEREO" indicator will go out, and the "MONO" indicator will light up.)

The broadcast will be monaural, but noise will be reduced.

If the button is pressed once more, the stereo mode will be resumed.

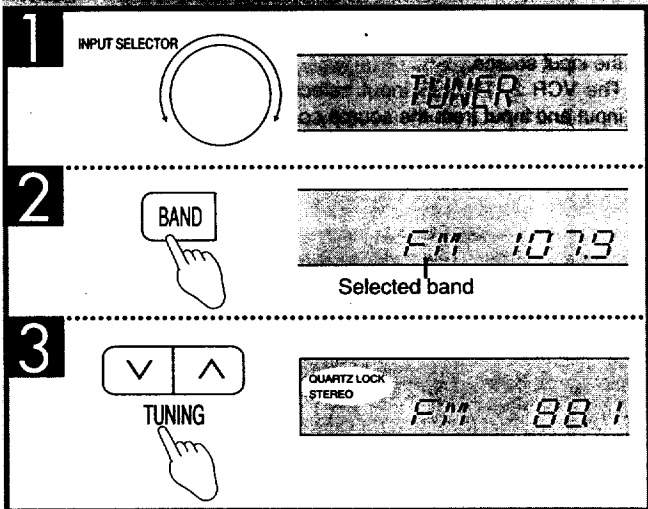
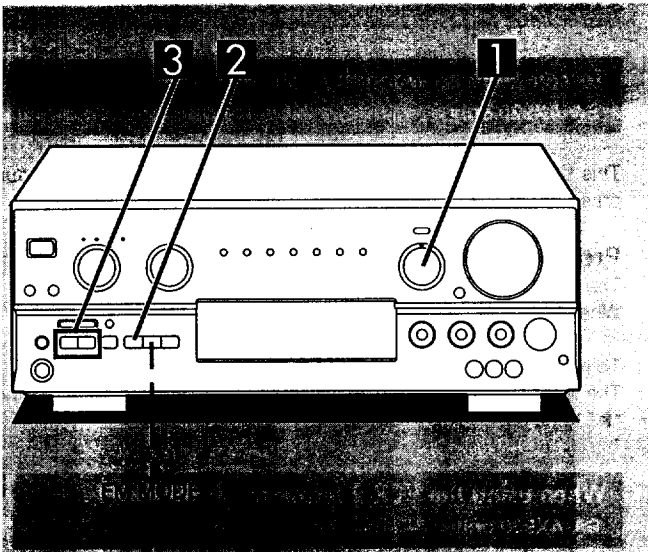

Direct tuning

(Only available from the remote control.)

Specify the frequency using the numeric buttons on the remote control transmitter to directly tune to the desired station.

- 1** Press **TUNER/BAND**.
This will set the remote control to operate the tuner. The selector on the receiver will change to TUNER. Each time the button is pressed, the band will change, FM \rightleftharpoons AM
- 2** Press **DIRECT TUNING/DISC ENTER**.
- 3** Press the appropriate numeric buttons to enter the frequency, while cursor display is flashing.

Tuning intervals FM: 0.1 MHz
 AM: 10 kHz

If the desired FM frequency is 107.9 MHz, press

[1] → [0] → [7] → [9]

If the frequency has been input correctly, the displayed frequency will blink once.

Note

1. If no button is pressed while the cursor display is flashing, the display will return to the frequency which is currently being received. To re-specify the frequency, repeat the procedure from step 2.
2. If the frequency has not been input correctly, "ERROR" will be displayed. In this case, re-enter the frequency.

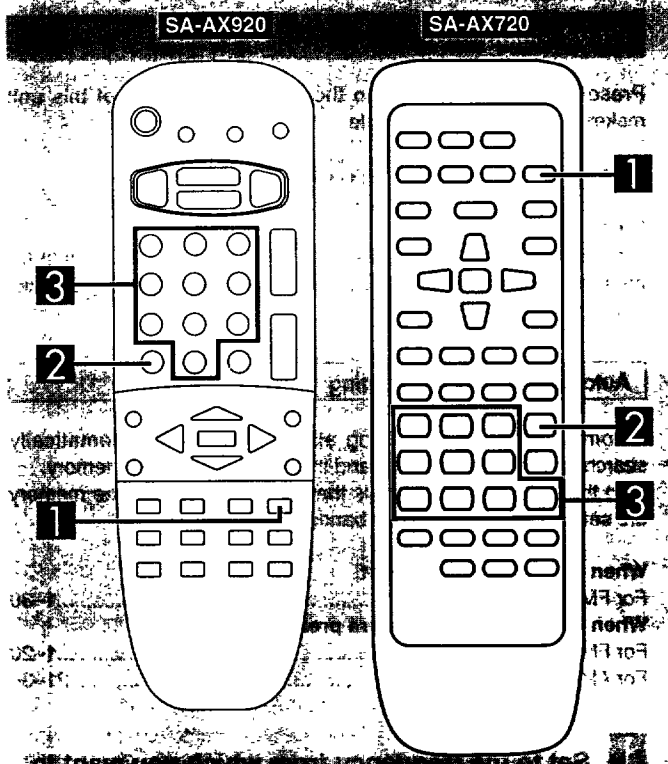

1

SA-AX920

SA-AX720

Selected band

2

SA-AX920

SA-AX720

(approx. 10 seconds)

3

SA-AX920

SA-AX720

Preset tuning

Presetting radio stations into the memory channels of this unit makes selecting stations simple.

A total of 30 FM and AM stations can be preset.

Please remember this

If a new broadcast station is preset into a channel, the setting for the broadcast station which was previously entered in that channel will be automatically erased.

Automatic memory presetting

Automatic memory presetting allows this unit to automatically search for broadcast stations and then preset them into memory. With this method, the channels that can be preset into the memory are set as follows for different bands (FM or AM).

- When FM stations are preset,**
For FM stations.....1-30
- When FM and AM stations are preset,**
For FM stations.....1-20
For AM stations.....21-30

- 1 Set to the frequency from which you want to start automatic memory presetting.**
(See page 20-21.),
- 2 Press MEMORY until the frequency begins to change.**
(Automatic memory presetting will start.)
During automatic memory presetting, the memory indicator will flash while the frequency scrolls.

To stop, press MEMORY once again.

When a broadcast station is preset **A**

The memory indicator and the preset channel number will be displayed for approximately 1 second.

When presetting is completed

The last broadcast station to be preset will be displayed.

Note

Frequencies may not be preset correctly in cases where the broadcast waves are too strong or too weak. In such cases, carry out presetting manually. (See page 23.)

Operation

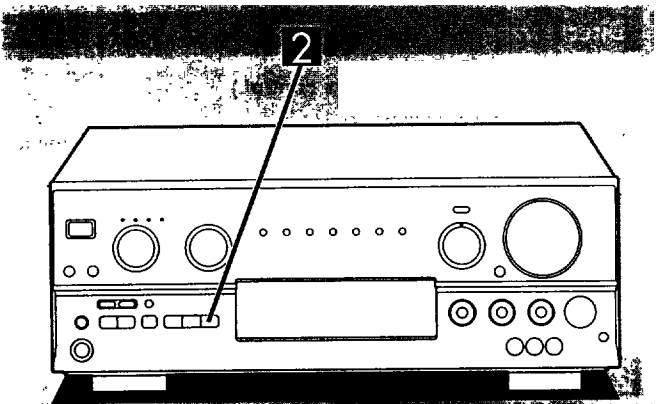

of and...
si valqab...

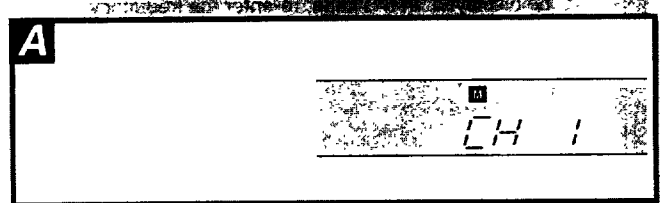
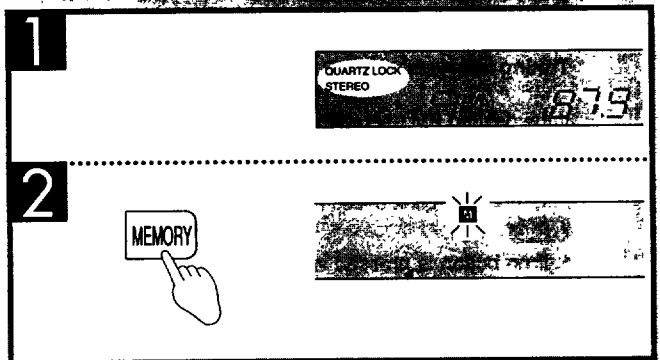

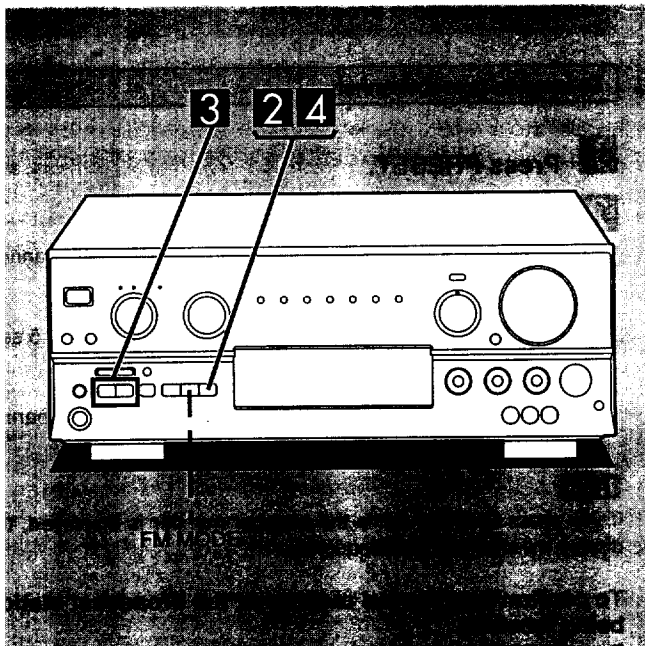

Manual memory presetting

The desired stations can be preset into the desired channels by the user.

- 1 Set to the desired frequency.**
(See page 20–21.)

If interference or static is keeping you from enjoying an FM station, press FM MODE and change to monaural. You can preset the memory in monaural just as in stereo.

- 2 Press MEMORY.**
To cancel the memory function, press MEMORY again.

- 3 Press TUNING (V) or (^) to select the desired channel.**
Holding the buttons down lets you scroll through channels faster.

- 4 Press MEMORY.**
The channel will blink on the display.

To continue presetting
Repeat steps 1 through 4.

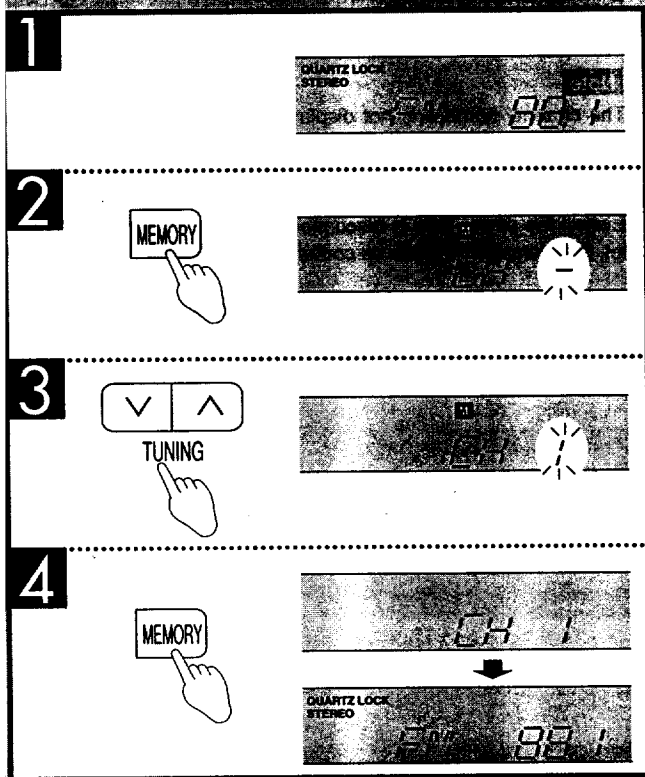

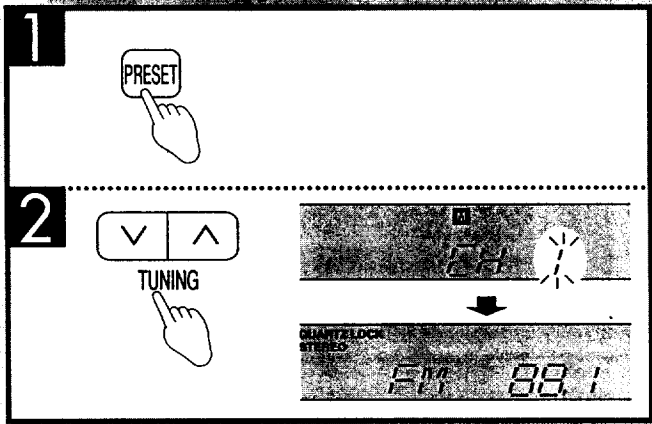
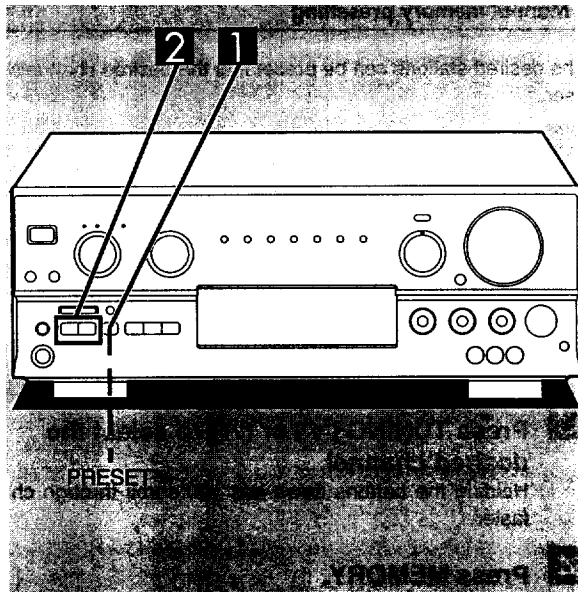

To listen to preset channels

- 1** Press PRESET.
- 2** Press TUNING (∇) or (▲).
Holding down the buttons lets you scroll through channels faster.

The channel number will be changed for approximately 5 seconds. Select the desired channel number during that time. After 5 seconds, the display will change from the channel number to the frequency.

Note

If you press PRESET while the channel number is displayed, the display will change to the frequency.

To confirm the channel number of the broadcast station being received

Press PRESET.
(The channel number will be displayed for approximately 5 second.)

Note

The channel number is not displayed if you change the reception frequency or FM mode setting.

For your reference

Even if the power cord is disconnected from the household AC outlet, the memory will retain its contents for approximately one month.

If frequency presettings are accidentally erased

Program the presettings once again. The power cord should remain connected for one hour or more for the memory back-up to be effective.

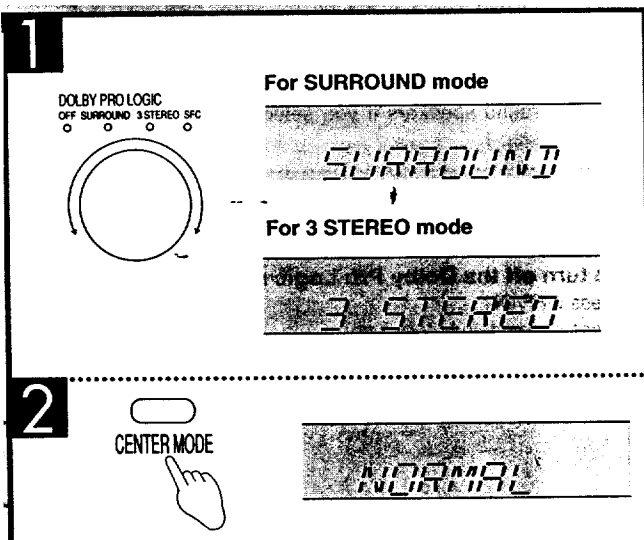
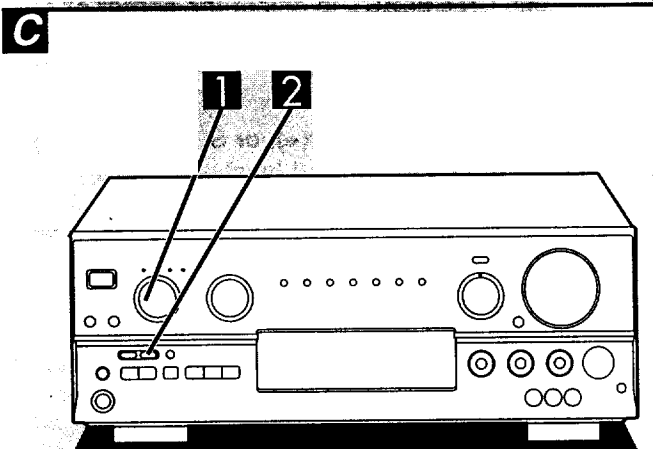
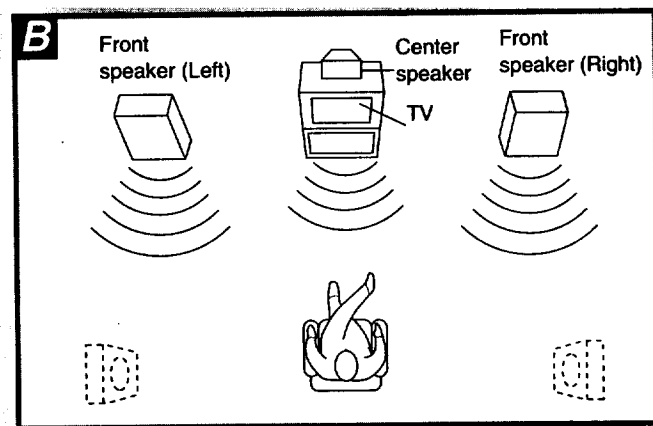
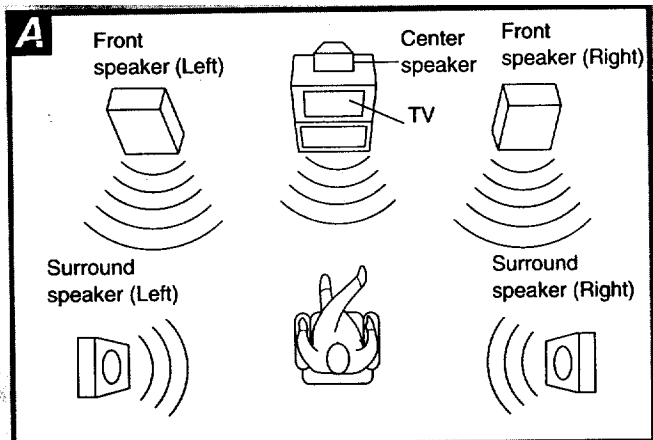

Dolby Pro Logic lets you enjoy movie software (video tapes and DVDs) in your own home with the same powerful stereophonic effect found in movie theaters. This unit has two Dolby Pro Logic modes: SURROUND and 3 STEREO.

SURROUND A

By reproducing the feeling of depth and movement of sound, video software or compact discs recorded with Dolby Surround provide the listener with a feeling of presence like that of a movie theater.

3 STEREO B

You can enjoy audio/video sources with clear sound, more presence and a good feeling of orientation. 3 STEREO can be used with stereo sources not encoded with DOLBY SURROUND.

Setting the center mode and adjusting speaker output level C

- Note**
- When ready to adjust speaker output level, situate yourself where you would normally be listening.
 - First turn ON the speakers with the SPEAKERS A or B button on the receiver.
 - If the front speaker volume is unbalanced, adjust the balance with the BALANCE control.

1 Turn the selector to select SURROUND mode.

- Note**
- Select 3 STEREO if surround speakers have not been connected.

2 Press CENTER MODE to select the correct center mode.

When the button is pressed, the current center mode is displayed. Pressing it again changes the center mode.

- NORMAL**
When the center speaker is smaller than the front speakers.
- WIDEBAND**
When the center speaker is the same size as or larger than the front speakers.
- PHANTOM SURROUND mode only**
When no center speaker is connected.

- Note**
- In the PHANTOM mode, the sound which would have been sent to the center speaker will be divided equally between both the left and right front speakers.

(Continued on next page)

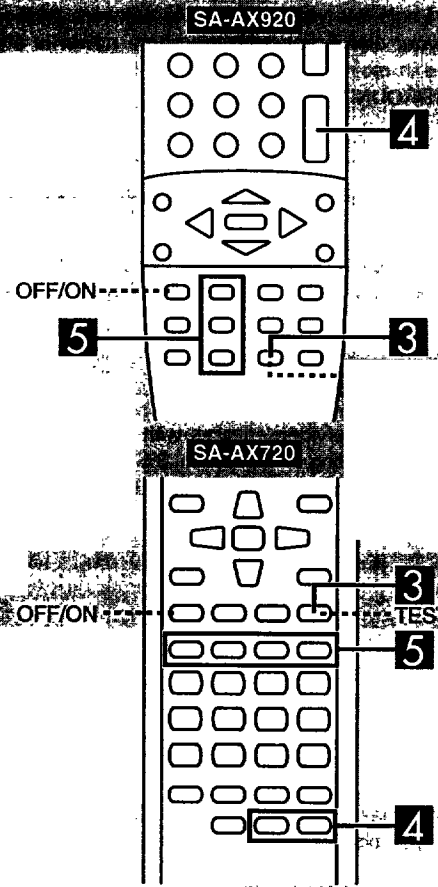

3 by remote control only

Press TEST to output a test signal.

The speaker outputting the test signal is displayed while the test is running.

- L : Front speaker (Left)
- C : Center speaker
- R : Front speaker (Right)
- S : Surround speakers

For SURROUND mode

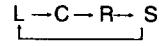

In the PHANTOM mode, the center speaker is OFF, so there is no center test signal and "C" is not displayed.

For 3 STEREO mode

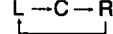

4 by remote control

Press VOL (-) or (+) to set the volume level normally used for enjoying the source.

The following steps are for setting the output level of the front speakers and the center/surround speakers to the same listening level.

5 by remote control only

For SA-AX920

Press CH SELECT to select the center or surround speakers, and press LEVEL (+) or (-) to adjust the output level.

For SA-AX720

Press CENTER (-) or (+), or SURROUND (-) or (+) to adjust the output level.

Adjust the output level of each speaker from the listening position until they are all identical.

- : Decrease the output level.
- +: Increase the output level.

Output level can be varied within a range of -12 dB to +12 dB with front speaker output level serving as the zero point.

Note

1. During step 5 above the test signal sequence is interrupted and the signal will only come from the selected speaker. The sequence will resume when adjustments are stopped.
2. Remember you cannot adjust the output level of the surround speakers if you selected the 3 STEREO mode in step 1.

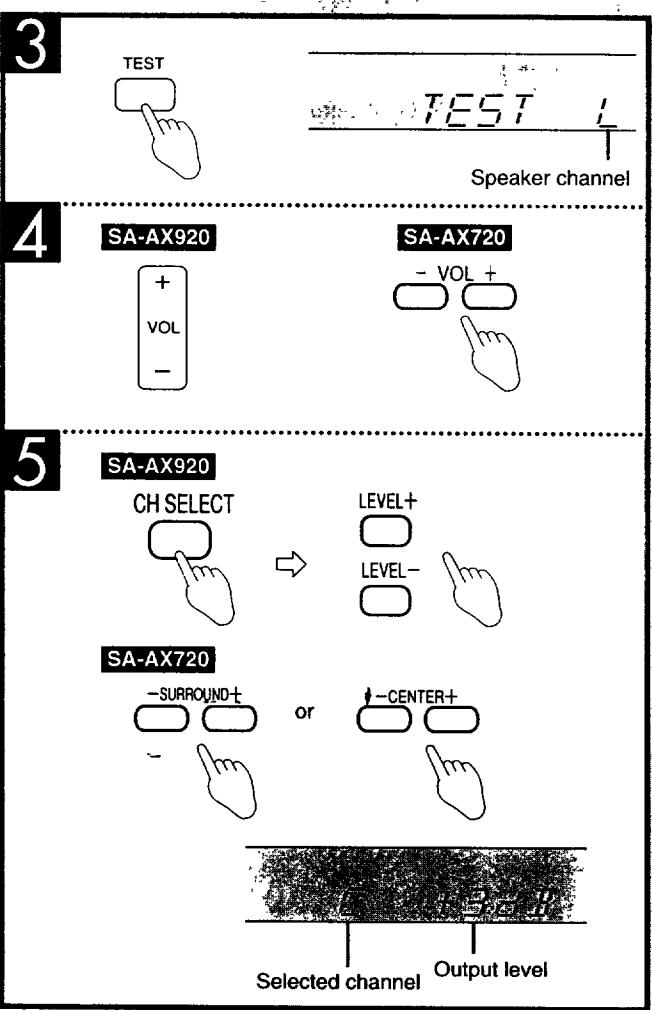

To stop the test signal

Press TEST.

To turn off the Dolby Pro Logic systems

Press OFF/ON.
Press once again to turn it on.

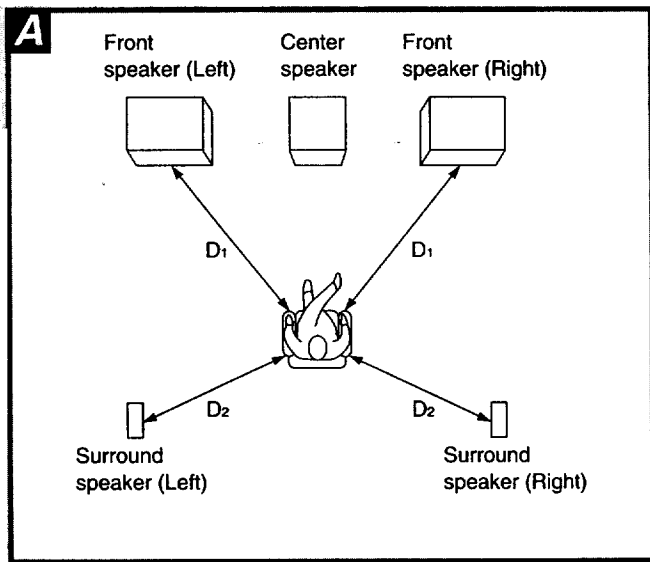
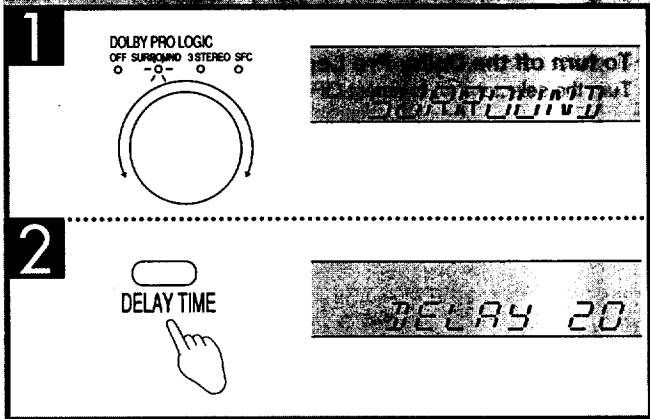
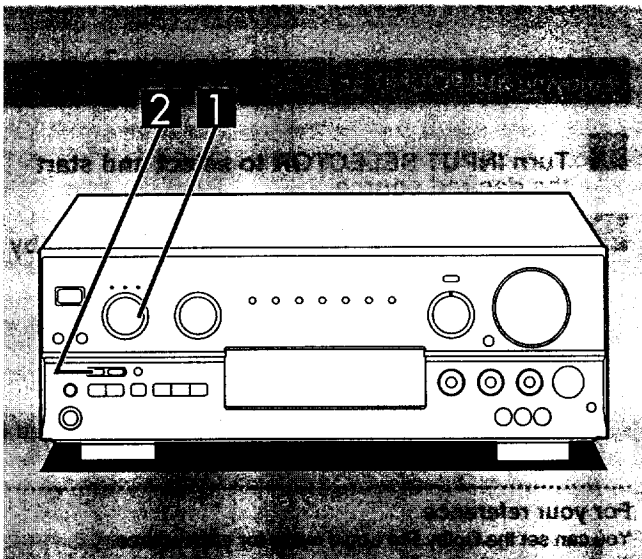

Enjoying sound with DOLBY PRO LOGIC

Adjusting the delay time

When enjoying with SURROUND only

Adjust the sound from the surround speakers until the proper effect is produced.

1 Turn the selector to select the SURROUND mode.

2 Press DELAY TIME to set the time.
 When the button is pressed, the current delay time is displayed.
 Pressing it again changes the delay time.
 Each time the button is pressed, the delay time will increase by 5 ms within a range of 15 ms to 30 ms.

The standard setting is 20 ms.

To calculate the delay time **A**

- D₁: Distance from front speakers
- D₂: Distance from surround speakers
- If D₁ is equal to or less than D₂
 Set to 15ms.
- If D₂ is less than D₁
 Start at 15ms and increase by 5 ms for every 1.5 m (5 feet) of difference between D₁ and D₂.

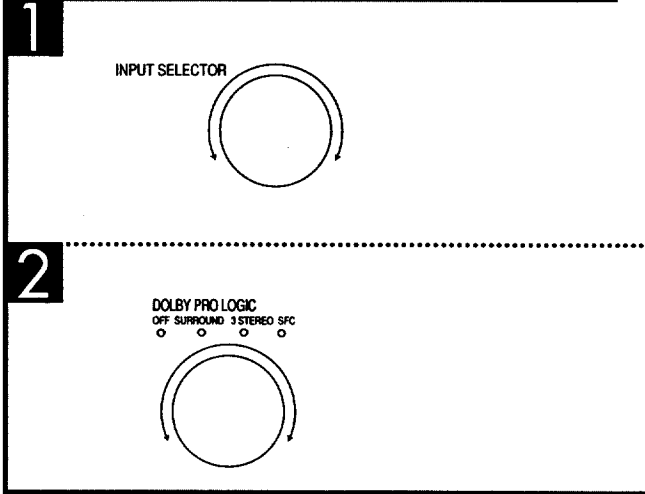
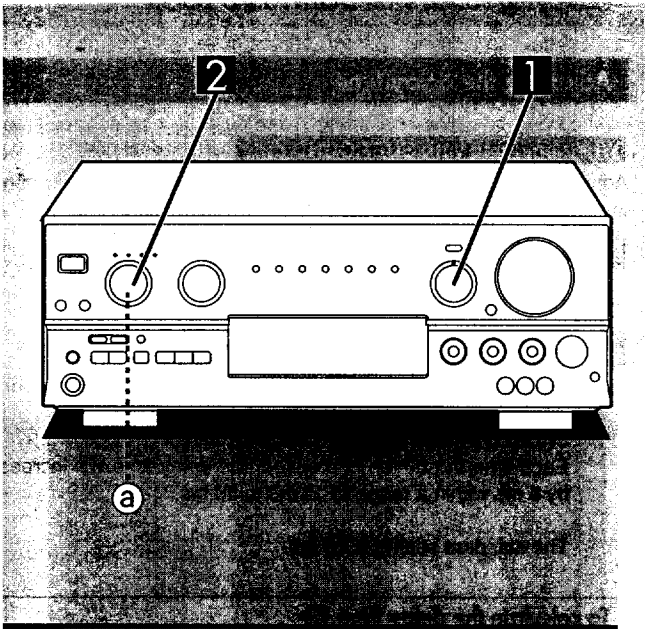

Enjoying SURROUND or 3 STEREO

- 1** Turn **INPUT SELECTOR** to select and start the desired source.
- 2** Turn the selector to select the desired **Dolby Pro Logic mode**.
The selected mode will be displayed.
The indicator which corresponds to the selected mode will illuminate.

Note

When employing SURROUND, use software recorded in Dolby Surround.

For your reference

You can set the Dolby Pro Logic mode for each source. Each source will retain the selected mode.

To turn off the Dolby Pro Logic systems

Turn the selector (ⓐ) to select OFF.

Manufactured under license from Dolby Laboratories Licensing Corporation.
 DOLBY, the double-D symbol  and "PRO LOGIC" are trademarks of Dolby Laboratories Licensing Corporation.

SFC is the abbreviation of Sound Field Control. The SFC function gives presence and spread thereby enhancing and enriching the music or movie. Read the following explanations in order to better understand how to make your selection.

HALL

This mode imparts a reflection and spread which will make you feel as if you are in a large concert hall.

CLUB

Like a jazz club, this mode provides an exciting and intimate atmosphere. It simulates the sound field of a relatively small room having a low ceiling and hard reflective surfaces, for a "live" sound with enhanced presence to bring the performers up close.

LIVE

Primarily for vocal pieces, this mode adds gloss to the vocals and you'll feel as though you were hearing a live stage performance.

THEATER

You can clearly perceive the directions and source of the movie. Real ambience of sound can also be recreated naturally using this mode.

THEATER mode can be used with stereo sources not encoded with DOLBY SURROUND.

Note

When using Dolby Surround encoded materials, select DOLBY PRO LOGIC SURROUND.

SIMULATED (SIM SURR)

Choose this mode if little or no sound will be heard from the surround speakers.

You can feel as if you were in a more expanded space adding to the actual sound from the source.

This mode also adds effect to monaural sources by outputting sound from surround speakers.

Note

You can adjust center speaker volume only in the theater mode. The center speaker is not used in the hall, and simulated modes.

1 Turn INPUT SELECTOR to select and start the desired source.

2 Turn the selector to select SFC.

3 Turn MODE to select the desired SFC mode.

Note

The SFC mode can also be selected by directly turning MODE in step 2 instead of selecting SFC.

For your reference

You can set the SFC mode for each source. Each source will retain the selected mode.

To turn off the SFC function

Turn the selector (a) to select OFF.

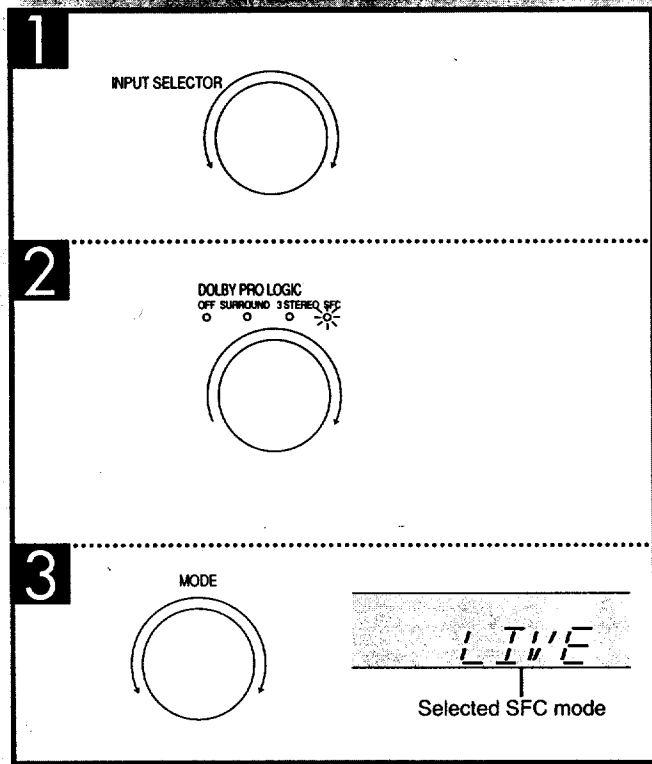
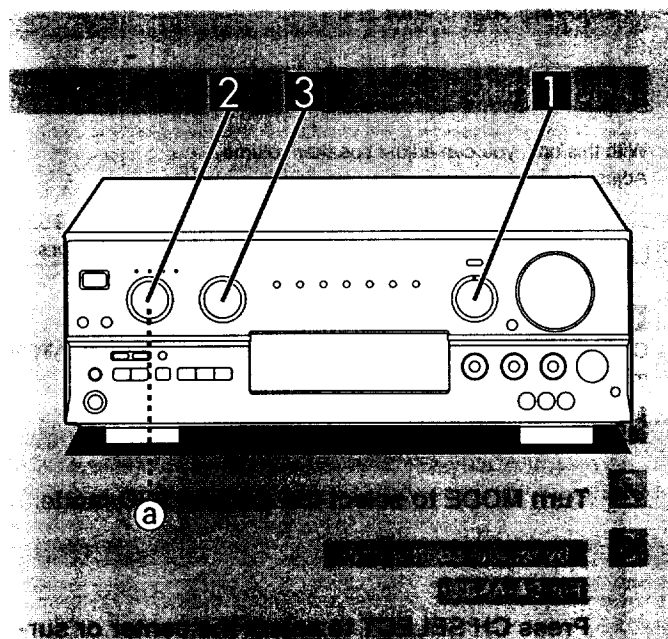

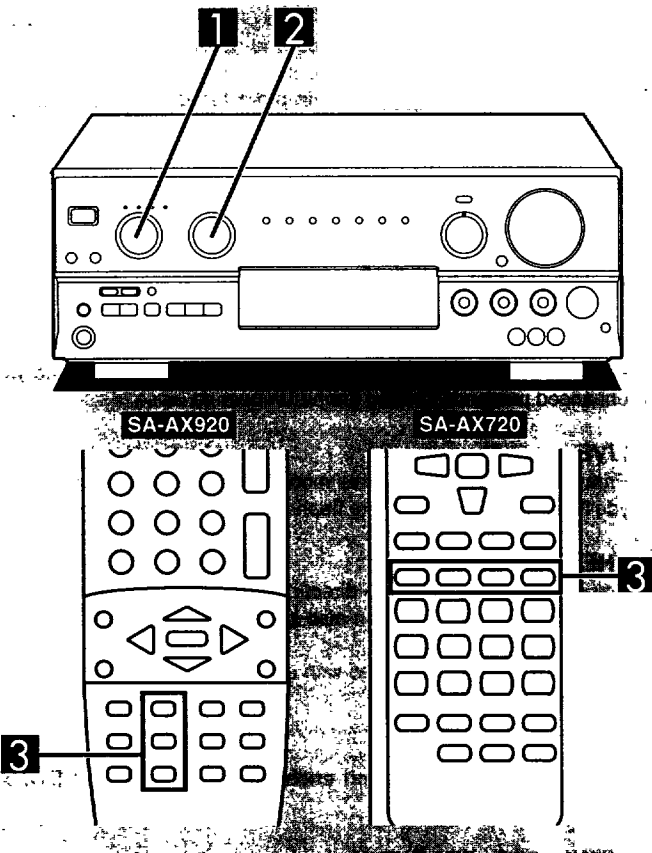

Adjusting field of sound

With this unit, you can adjust speaker volume.
Adjust the field of sound while listening to a source.

To adjust the volume of the center and surround speakers

Note

Center speaker volume can be adjusted only in the THEATER mode.

- 1 Turn the selector to select SFC.
- 2 Turn MODE to select the desired SFC mode.

3 by remote control only

For SA-AX920

Press CH SELECT to select the center or surround speakers, and press LEVEL (+) or (-) to adjust the output level.

For SA-AX720

Press CENTER (-) or (+), or SURROUND (-) or (+) to adjust the output level.

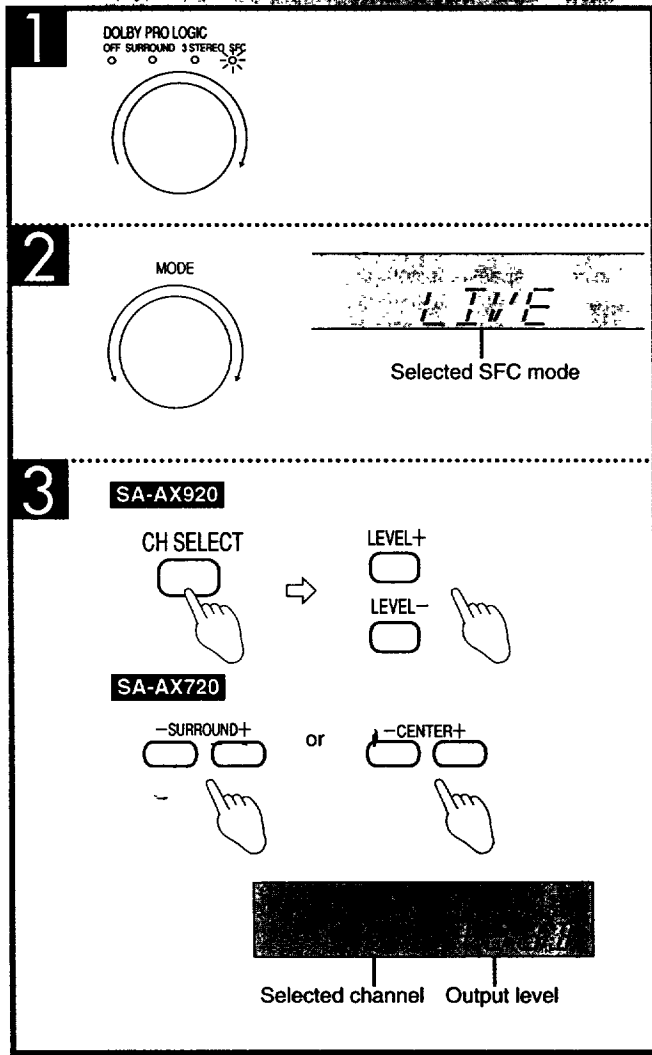

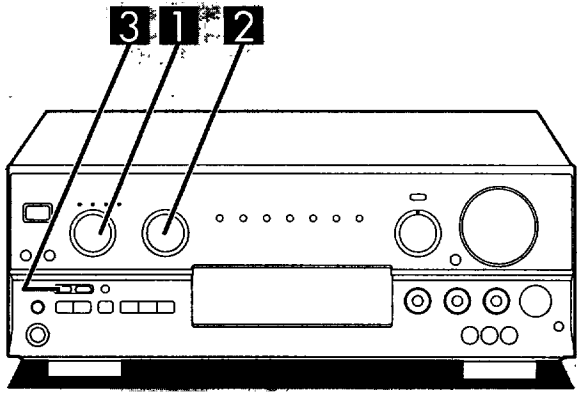

To adjust the delay time

- 1** Turn the selector to select SFC.
- 2** Turn MODE to select the desired SFC mode.
- 3** Press DELAY TIME to set the time.

When the button is pressed, the current delay time is displayed. Pressing it again changes the delay time.

Each time the button is pressed, the delay time will change.

The delay time increments are different depending on the SFC mode. Select a delay time setting to accommodate to your individual needs.

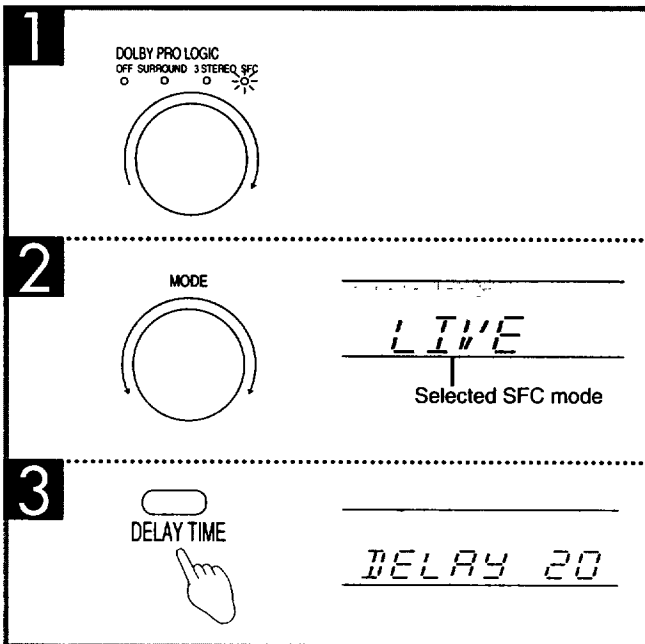

SFC modes	Available delay time setting (ms)
HALL	40, 50, 20, 25, 30
CLUB	15, 20, 25, 30, 0
LIVE	50, 15, 20, 30, 40
THEATER	20, 25, 30, 40, 15
SIMULATED	15, 20, 25, 30, 40

Enjoying sound with 6 channel discrete

This receiver can playback 6 channel discrete sound. It has terminals for connecting to component with 6 channel discrete output, such as a DVD player.

6 channel discrete output makes playback sound more real by adding depth, movement, position and other characteristics to the field of sound.

It will make you feel as if you were at the movie theater when in your own home.

To enjoy 6 channel discrete output sound

You have to connect a DVD player or other component that has 6 channel discrete output capabilities.

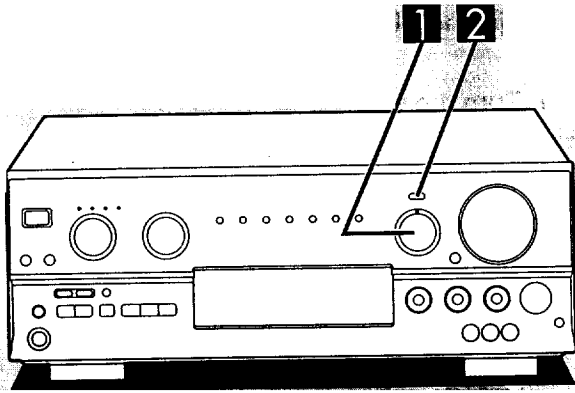

1 Turn **INPUT SELECTOR** to select **DVD**.

2 Press **DVD 6CH INPUT** to select **DVD 6CH**.
Changes as follows, each time the button is pressed.

- DVD 6CH ⇄ DVD (2CH)

If you press this button while another source (CD, PHONO, etc.) is selected, the receiver switches the source to DVD and engages the DVD 6CH INPUT mode.

3 Start the desired source.

Follow your equipment's operating instructions.

Note

You cannot select Dolby Pro Logic or any of the SFC modes while in the DVD 6CH INPUT mode. If you try, the message "NOT POSSIBLE IN 6CH DISCRETE INPUT" will appear on the display.

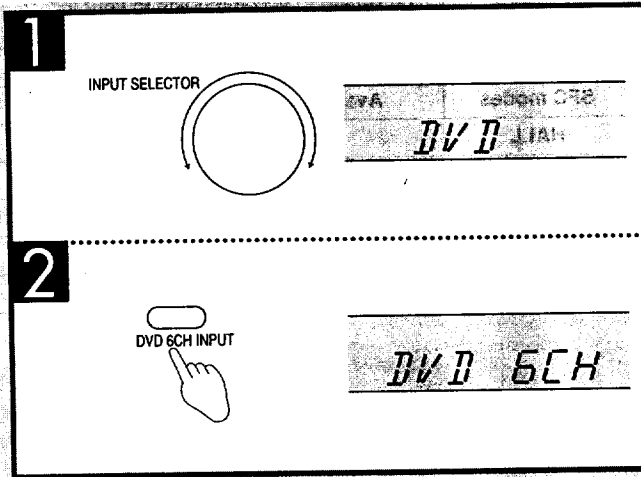

Making a recording

Note

When you select DVD 6CH INPUT mode, only sound from the front left and right speakers is recorded.

To record all 6 channels

Set the playback mode on your DVD player or decoder to 2 channel (stereo) mode.

For details, see the instruction manual that came with the connected equipment.

Recording on a tape deck

Before recording, prepare the tape deck for recording (recording level adjustment, etc.).

See the tape deck's operating instructions for details.

1 Turn INPUT SELECTOR to select the source to be recorded.

Any source can be selected except TAPE.

2 SA-AX920 only

(only if you select TV/DSS/VCR 2 in the above step)

Set " **VCR 2**" or " **TV/DSS**" position.

3 Begin recording on the tape deck.

Follow your tape deck's operating instructions.

4 Begin the source to be recorded.

Follow your equipment's operating instructions.

Recording on a VCR

Before recording, prepare the VCR 1 (VCR) for recording (recording level adjustment, input selector setting, etc.).

See the VCR's operating instructions for details.

1 Turn INPUT SELECTOR to select the source to be recorded.

Any source can be selected except VCR 1 (VCR) and TAPE.

Note

Recording from the tape deck is not possible.

2 SA-AX920 only

(only if you select TV/DSS/VCR 2 in the above step)

Set " **VCR 2**" or " **TV/DSS**" position.

3 Begin recording on the VCR.

Follow your VCR's operating instructions.

4 Begin the source to be recorded.

Follow your equipment's operating instructions.

For your reference SA-AX920 only

There are VCR 2 terminals at the front of this unit.

It is easier to carry out dubbing from a camcorder if it is connected to the front terminals.

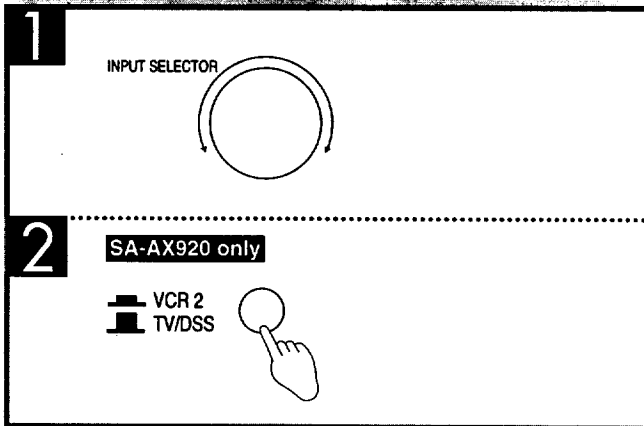
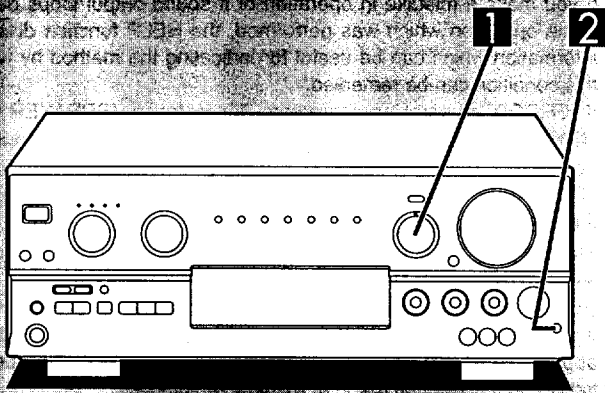
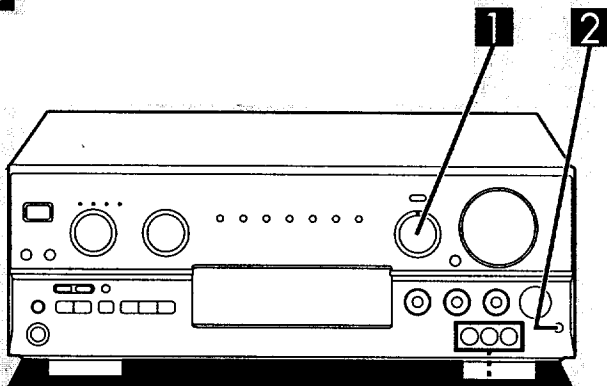
A**B**

VCR 2 terminals

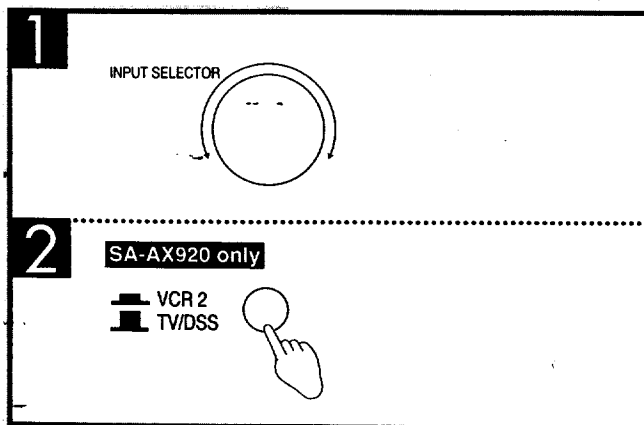

About the HELP function

If you make a mistake in operation or if sound output stops due to some operation which was performed, the HELP function displays information which can be useful for indicating the method by which this condition can be remedied.

If "ERROR" or scrolling characters (for instance, "SPEAKER OFF NOW") appear on the display during operation, carry out the following operation.

Press -HELP.

The method for remedying this situation will be displayed.

For your reference

If the above button is pressed for 2 seconds or more until "RESET" appears on the display, the operation settings for the unit will be initialized to the settings made at the time of shipment.

However, any broadcasting stations which have been preset into memory will not be erased at this time.

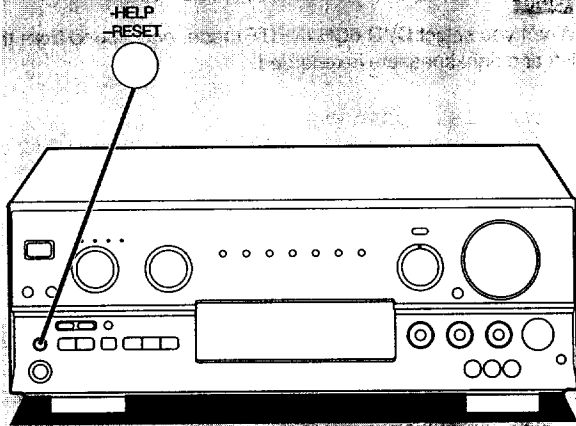

Product service

Do not attempt to remove the cover(s) or repair the unit yourself.

Refer servicing to qualified personnel only.

Product information

For product service, product information or assistance in product operation, refer to the servicenter directory.

Troubleshooting guide

Before requesting service for this unit, check the chart below for a possible cause of the problem you are experiencing. Some simple checks or a minor adjustment on your part may eliminate the problem and restore proper operation.

If you are in doubt about some of the check points, or if the remedies indicated in the chart do not solve the problem, refer to the directory of Authorized Service Centers (enclosed with this unit) to locate a convenient service center, or consult your Technics dealer for instructions.

(In U.S.A. consult PASC Authorized Servicenters for detailed instructions or call 1-800-211-7262 for the address of an authorized factory servicenter.)

Reference pages indicated in black circles. (For example: ⑧)

Problem	Probable cause(s)	Suggested remedy
While listening to FM broadcasts		
An unusual hissing noise is heard when listening to the broadcast in stereo, but not heard when listening monaurally.	A slight noise may be heard because the method used for modulation of FM stereo broadcasts is different than that used for monaural broadcasts.	<ul style="list-style-type: none"> • Try reducing the treble sound by using the treble control. (⑧) • Try changing the location, height and/or direction of the antenna. (⑧ ⑨) • If an indoor antenna is being used, change to an outdoor antenna. (⑩) • Try using an antenna with more elements.
Noise is excessive in both stereo and monaural broadcasts.	Poor location and/or direction of the antenna. Transmitting station is too far away.	
The FM stereo indicator or the quartz lock indicator flickers, without completely illuminating.	Poor location and/or direction of the antenna. Transmitting station is too far away.	<ul style="list-style-type: none"> • Try changing the location, height and/or direction of the antenna. (⑧ ⑨) • If an indoor antenna is being used, change to an outdoor antenna. (⑩) • Try using an antenna with more elements.
Excessive distortion in the sound of stereo broadcasts.	Nearby building or mountain.	

While listening to AM broadcasts		
An unusual "beat" sound is heard.	Unit is being used at the same time as the television set.	• Turn off the television set, or use this unit farther away from it.
	Interference from adjacent broadcast signal.	• Try reducing the treble sound by using the treble control. (⑧)
A low-pitched "hum" sound is heard when the station is tuned.	The AM loop antenna connection wires are too close to the power cord.	• Place the antenna connection wires and the power cord farther apart.
	The power supply frequency from the power cord is modulated and heard from the speakers.	• Install a special outdoor antenna. (⑩)
A strange hissing noise is produced continuously or intermittently.	Caused by the "discharge phenomenon" and the "oscillation phenomenon" of electric appliances (such as fluorescent lights, TV, small series-type motors, rectification equipment, etc.).	• Try placing this unit farther away from such equipment.

Common Problems		
Power will not switch ON.	The power cord plug is not completely inserted.	• Confirm that the power cord plug is connected completely.
No sound is heard.	The speaker indicator(s) is(are) turned off.	• Turn on the speaker indicator(s). (⑩)
	The muting function is ON.	• Press the muting button. (⑩)
	Connections to the speaker systems or external equipment are incomplete or incorrect.	• Check that all wires and cables are correctly connected. (⑦-⑨, ⑪-⑬)
	The incorrect input source has been selected.	• Check that the correct source is selected. (⑭)
Sound stops during a performance, or no sound is heard when the power is switched ON. (The word "OVERLOAD" appears on the display.)	The protection circuitry has functioned because the positive and negative speaker connection wires have "shorted," speaker systems with an impedance less than the indicated rated impedance of this unit have been used or are under severe use, such as through excessive volume, excessive power or being in an excessively hot environment.	<ul style="list-style-type: none"> • Switch off the power, and after determining and correcting the cause, switch on the power once again. • Use a speaker system of the proper impedance rating. (⑭-⑮)

■ AMPLIFIER SECTION

Rated minimum sine wave RMS power output
 20 Hz–20 kHz both channels driven
 0.05% total harmonic distortion
 100 W per channel (8 Ω)

1 kHz continuous power output both channels driven
 0.05% total harmonic distortion 105 W per channel (8 Ω)

Total harmonic distortion
 rated power at 20 Hz–20 kHz 0.05% (8 Ω)
 half power at 1 kHz 0.03% (8 Ω)

Power output at the Dolby Pro Logic operation
 0.9% at 1 kHz,
 Front 2×100 W (8 Ω)
 Center 100 W (8 Ω)
 Surround 2×100 W (8 Ω)
 Subwoofer [SA-AX920 only] 100 W (8 Ω)

Low frequency damping factor 30 (8 Ω)

Load impedance
 Front
 [SA-AX920]
 A or B 4–8 Ω
 A and B 8 Ω
 [SA-AX720]
 A or B 8 Ω
 A and B 8 Ω
 Center 8 Ω
 Surround 8 Ω
 Subwoofer [SA-AX920 only] 8 Ω

Dynamic headroom 2 dB (8 Ω)

Frequency response
 PHONO RIAA standard curve ± 0.8 dB
 [SA-AX920] CD, TAPE, DVD, VCR 1, TV/DSS/VCR 2
 10 Hz–70 kHz, ±3 dB
 [SA-AX720] CD, TAPE, DVD, VCR, TV/DSS
 10 Hz–70 kHz, ±3 dB

Input sensitivity
 PHONO 0.4 mV (3 mV, IHF'66)
 [SA-AX920] CD, TAPE, DVD, VCR 1, TV/DSS/VCR 2
 27 mV (200 mV, IHF'66)
 [SA-AX720] CD, TAPE, DVD, VCR, TV/DSS
 27 mV (200 mV, IHF'66)

S/N (IHF A)
 PHONO 70 dB (80 dB, IHF'66)
 [SA-AX920] CD, TAPE, DVD, VCR 1, TV/DSS/VCR 2
 75 dB (85 dB, IHF'66)
 [SA-AX720] CD, TAPE, DVD, VCR, TV/DSS
 75 dB (85 dB, IHF'66)

Input impedance
 PHONO 47 kΩ
 [SA-AX920] CD, TAPE, DVD, VCR 1, TV/DSS/VCR 2
 22 kΩ
 [SA-AX720] CD, TAPE, DVD, VCR, TV/DSS
 22 kΩ

Tone controls
 BASS 50 Hz, +10 to –10 dB
 TREBLE 20 kHz, +10 to –10 dB

Loudness control (volume at –30 dB) [SA-AX920 only]
 50 Hz, +9 dB

Subwoofer frequency response 7–100 Hz, ±3 dB

■ FM TUNER SECTION

Frequency range 87.9–107.9 MHz

Sensitivity 11.2 dBf (2 μV, IHF '58)

50 dB quieting sensitivity
 MONO 18.3 dBf (4.5 μV, IHF '58)
 STEREO 38.3 dBf (45 μV, IHF '58)

Total harmonic distortion
 MONO 0.2%
 STEREO 0.3%

S/N
 MONO 73 dB
 STEREO 67 dB

Frequency response 20 Hz–15 kHz, +1 dB, –2 dB

Alternate channel selectivity 65 dB

Capture ratio 1.5 dB

Image rejection at 98 MHz 40 dB

Spurious response rejection at 98 MHz 75 dB

AM suppression 50 dB

Stereo separation
 1 kHz 40 dB
 10 kHz 30 dB

Antenna terminal 75 Ω (unbalanced)

■ AM TUNER SECTION

Frequency range 530–1710 kHz

Sensitivity 20 μV, 330 μV/m

Selectivity 55 dB

IF rejection at 1000 kHz 50 dB

■ VIDEO SECTION

Output voltage at 1 V input (unbalanced) 1 ±0.1 Vp-p

Maximum input voltage 1.5 Vp-p

Input/output impedance 75 Ω

■ GENERAL

Power supply AC 120 V, 60 Hz

Power consumption
 [SA-AX920] 350 W
 (In standby condition: 2 W)
 [SA-AX720] 290 W
 (In standby condition: 2 W)

Dimensions (W×H×D)
 430×158×312 mm
 (16-15/16"×6-7/32"×12-9/32")

Weight
 [SA-AX920] 9.8 kg (21.8 lb.)
 [SA-AX720] 9.3 kg (20.7 lb.)

Notes:

- Specifications are subject to change without notice. Weight and dimensions are approximate.
- Total harmonic distortion is measured by the digital spectrum analyzer.

Panasonic Consumer Electronics Company, Division of Matsushita Electric Corporation of America
 One Panasonic Way Secaucus, New Jersey 07094

Panasonic Sales Company, Division of Matsushita Electric of Puerto Rico, Inc. ("PSC")
 Ave. 65 de Infantería. Km. 9.5 San Gabriel Industrial Park, Carolina, Puerto Rico 00985

Panasonic Canada Inc.
 5770 Ambler Drive, Mississauga, Ontario L4W 2T3



RQT4208-P

H1197V0