



ith

Wait... new Zenith
Entertainment Machine
Models
RA211
VRA4
VRA

thanks for
closing zenith

LIBRARY
Received
Copied
Entered
LIBRARY HANDS
9-21-98
9-21-98
9804051

zenith|entertainment machines

RECORD YOUR MODEL NUMBER
(Now, while you can see it)

The model and serial number of your new VCR are located on the back of the VCR cabinet. For your future convenience, we suggest that you record these numbers here:

MODEL NO. _____

SERIAL NO. _____

SAFETY TIPS:

Refer to the "Safety Tips" leaflet that came with your product for Important Safety Instructions.



WARNING:

TO REDUCE THE RISK OF ELECTRIC SHOCK DO NOT REMOVE COVER (OR BACK). NO USER SERVICEABLE PARTS INSIDE. REFER SERVICING TO QUALIFIED SERVICE PERSONNEL.



The lightning flash with arrowhead symbol, within an equilateral triangle, is intended to alert the user to the presence of uninsulated "dangerous voltage" within the product's enclosure that may be of sufficient magnitude to constitute a risk of electric shock to persons.



The exclamation point within an equilateral triangle is intended to alert the user to the presence of important operating and maintenance (servicing) instructions in the literature accompanying the appliance.

WARNING:

TO PREVENT FIRE OR SHOCK HAZARDS, DO NOT EXPOSE THIS PRODUCT TO RAIN OR MOISTURE.

POWER CORD POLARIZATION:

CAUTION: To Prevent Electric Shock, match wide blade of plug to wide slot, fully insert.

ATTENTION: Pour éviter les chocs électriques, introduire la lame la plus large de la fiche dans la borne correspondante de la prise et pousser jusqu'au fond.

NOTE TO CABLE/TV INSTALLER:

This reminder is provided to call the cable TV system installer's attention to Article 820-40 of the National Electric Code (U.S.A.). The code provides guidelines for proper grounding and, in particular, specifies that the cable ground shall be connected to the grounding system of the building, as close to the point of the cable entry as practical.

REGULATORY INFORMATION:

This equipment has been tested and found to comply with the limits for a Class B digital device, pursuant to Part 15 of the FCC Rules. These limits are designed to provide reasonable protection against harmful interference when the equipment is operated in a residential installation. This equipment generates, uses and can radiate radio frequency energy and, if not installed and used in accordance with the instruction manual, may cause harmful interference to radio communications. However, there is no guarantee that interference will not occur in a particular installation. If this equipment does cause harmful interference to radio or television reception, which can be determined by turning the equipment off and on, the user is encouraged to try to correct the interference by one or more of the following measures:

- Reorient or relocate the receiving antenna.
- Increase the separation between the equipment and receiver.
- Connect the equipment into an outlet on a circuit different from that to which the receiver is connected.
- Consult the dealer or an experienced radio/TV technician for help.

CAUTION:

Do not attempt to modify this product in any way without written authorization from Zenith Electronics Corporation. Unauthorized modification could void the user's authority to operate this product.

This class B digital apparatus meets all requirements of the Canadian Interference-Causing Equipment Regulations.

"Ce appareil numérique de la class b respecte toutes les exigences du Règlement sur le matériel brouilleur du Canada."

VCR Features Chart

This page shows the features of your VCR and the differences between the models

FEATURES	VRA211	VRA411	VRA421
SpeakEZ Function	X	X	X
2-Heads	X	N/A	N/A
4-Heads (Special Video Effects)	N/A	X	X
Full Load/Quick Start	X	X	X
Auto Head Cleaner	X	X	X
Audio System	Monaural	Monaural	MTS Hi-Fi Stereo
Audio/Video (A/V) Jacks	Monaural	Monaural	Stereo
Remote Control SC411	X	X	X
Auto/Manual Band Select	X	X	X
Auto/Manual Channel Search	X	X	X
Channel Capability (CATV & TV)	181	181	181
Record Speeds SP/EP	X	X	X
Playback Speeds SP/LP/EP	X	X	X
Auto Playback System	X	X	X
Auto/Manual Digital Tracking	X	X	X
Instant Recording	X	X	X
Timer-Controlled Recording	X	X	X
Auto Playback Tape Speed Adjust	X	X	X
Forward/Reverse Slow-Motion Video (4-head VCR)	N/A	X Variable 1/10 to 1/32	X Variable 1/10 to 1/32
Pause/Still Video	Noise	Clear	Clear
Real-Time Tape Counter	X	X	X
Speed Search	X	X	X
CM Skip	X	X	X
English/Spanish/French Menus	X	X	X
1-Year, 8-Event Timer	X	X	X
LED Front Panel Indicator	X	X	X
Auto Daylight Saving Time	X	X	X
Hook-up Cable (VCR to TV)	X	X	X

1. Model VRA421 is used for the description, operation, and details provided in this operating guide.
2. VCR design and specifications are subject to change without prior notice.

X = Feature is provided N/A = Feature is Not Available

Required connections for your VCR

Connections for your VCR

Connections Without a Cable Box

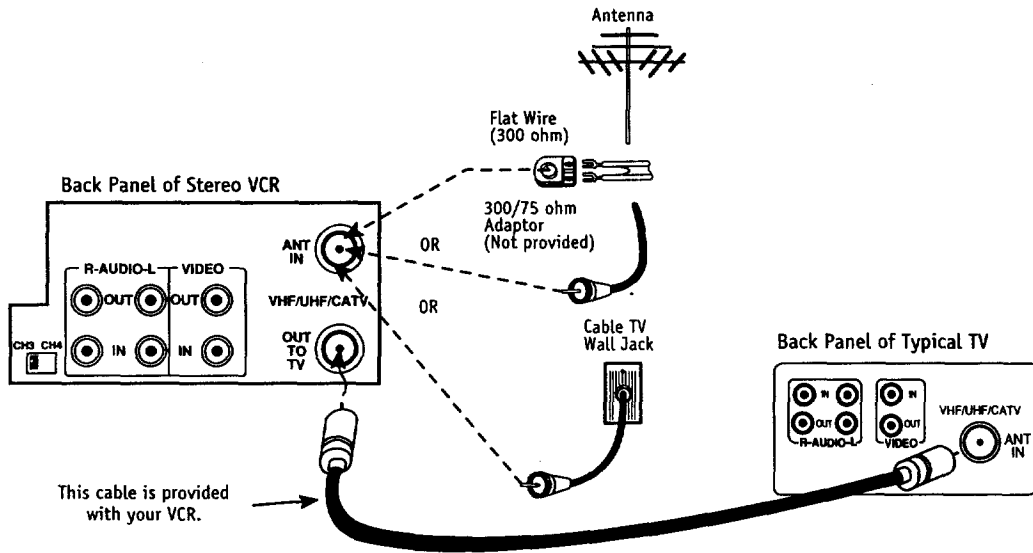

This cable is provided with your VCR.



Turn off power or unplug VCR before making any connections.

Connections With a Cable Box

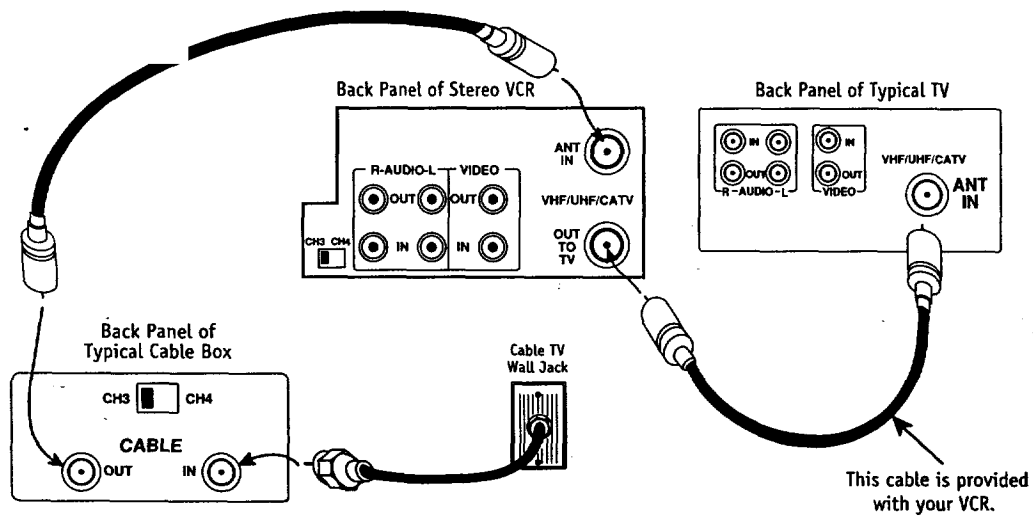

This cable is provided with your VCR.



Turn off power or unplug VCR before making any connections.

Connections for your VCR

Optional connections for your VCR

Audio/Video (A/V) Connections to TV

Use A/V connections for a better picture.

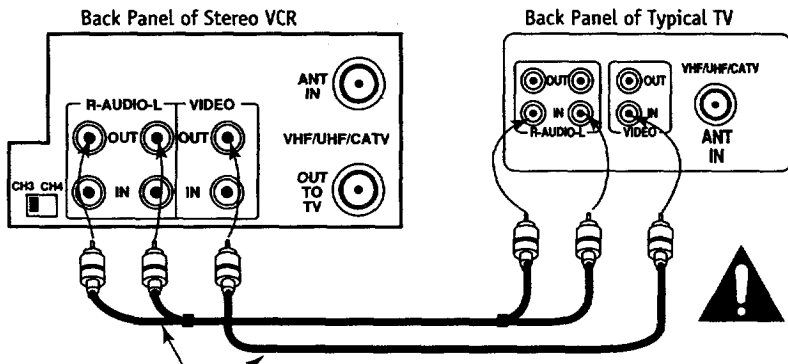

Turn off power or unplug VCR before making any connections.

A/V cable is not provided with VCR.

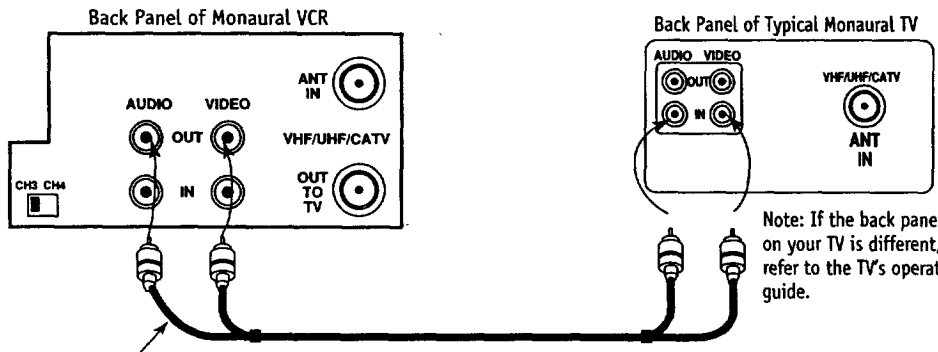

Note: If the back panel on your TV is different, refer to the TV's operating guide.

A/V cable is not provided with VCR.

Accessory Audio/Video (A/V) Connections to VCR

Accessory Component: Another VCR, Camcorder, Video Camera, Satellite Receiver, Laser Disc Player

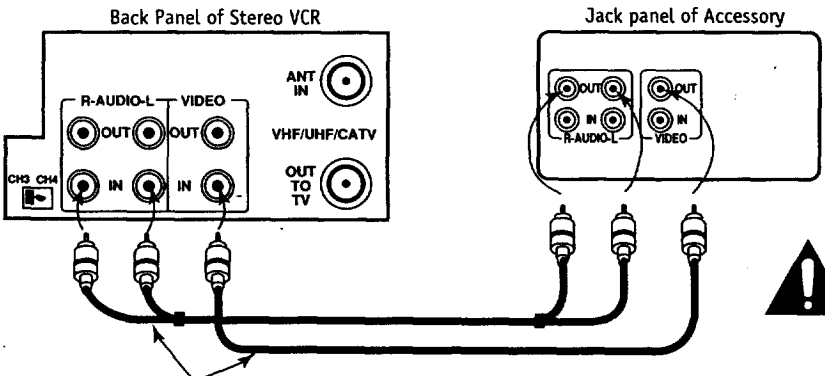

Turn off power or unplug VCR before making any connections.

A/V cable is not provided with VCR.

Things you must do before you can operate your VCR

Before you operate your VCR

CLOCK MENU
 AUTO DAYLIGHT SAVING: ON OFF
 MANUAL CLOCK SET:
 Press number keys
 QUIT = exit

CLOCK

PROGRAM
 MONTH :
 DAY :
 START :
 STOP :
 CHANNEL :
 SPEED :
 REPEAT :
 (1-9) to select program
 ENTER to adjust program

TIMER

SETUP MENU
 AUTO PROGRAM:
 CH. ADD/DEL:
 SOURCE:
 ON-SCREEN DISPLAY:
 LANGUAGE SELECT:
 Press number keys
 QUIT = exit

SETUP

AUDIO MENU
 SpeakeZ: ON OFF
 PLAYBACK:
 RECORD:
 Press number keys
 then ENTER QUIT = exit

AUDIO

Press NUMBER (1, 2, 3, 4) button

SpeakeZ
 CLOCK : 1
 TIMER : 2
 SETUP : 3
 AUDIO : 4
 Press number keys
 QUIT = exit

MAIN MENU

Note:
 Audio menu's PLAYBACK and RECORD options are available only with stereo VCRs.

1

Connect the Power

(Required) Plug your VCR into an unswitched 120 Vac, 60 Hz household power outlet. Turn on the VCR by pressing the POWER on the remote or on the VCR's front panel.



Do not plug the VCR into a switched power outlet. Otherwise, when the power is switched off, the VCR turns off. You may then have to reset the time and date, and reprogram operational features.

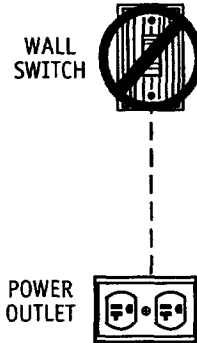

2

Set Position of the CH3/CH4 Switch

(Required) The CH3/CH4 switch on the VCR's back panel determines which channel the VCR uses to send video signals to your TV. The TV must be tuned to the same channel you set with the CH3/CH4 switch to see tape playback and status displays from the VCR. To determine which video channel provides the best picture for your system, try the switch in CH3 position and tune your TV to channel 3; then try the CH4 position and tune your TV to channel 4.

TYPICAL ZENITH VCR

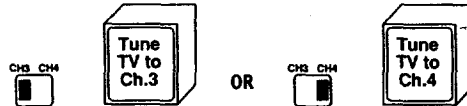

For a test display, press TV/VCR on remote repeatedly until the VCR indicator appears in the VCR's front panel display. Press MENU on the remote to see the main menu.

Before you operate your VCR

How to Access Menus

1. Press MENU to see Main Menu.
2. Press NUMBER (1, 2, 3, or 4) to see desired sub menu to be used.
3. Press NUMBER to choose desired option to be changed.
4. Press QUIT to exit menu, or wait a few minutes and the VCR returns to normal operation.

Things you must do before you can operate your VCR

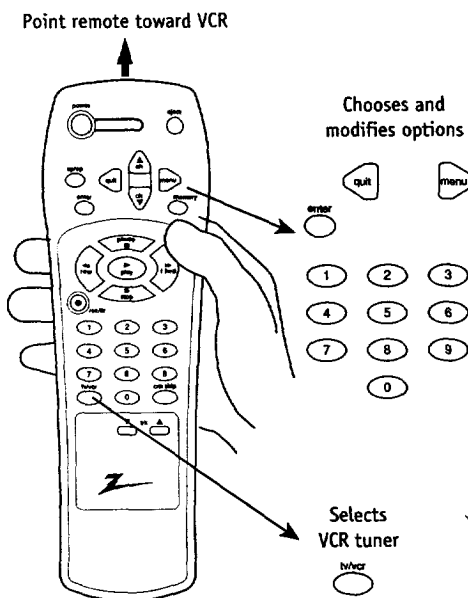

3

Select SpeakEZ Function (On/Off)

A voice tells you how to use the features in the menus if SpeakEZ is ON. (ON is recommended.)
See the AUDIO Menu for details.



SpeakEZ only functions with ENGLISH.

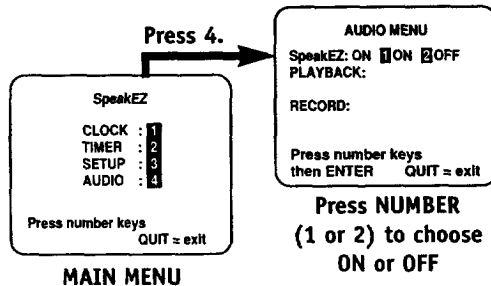

4

Select Language for VCR Menus/Displays

(Optional) Select English, Spanish, or French for VCR menus and status displays. See the LANGUAGE SELECT option on the SETUP menu for details.

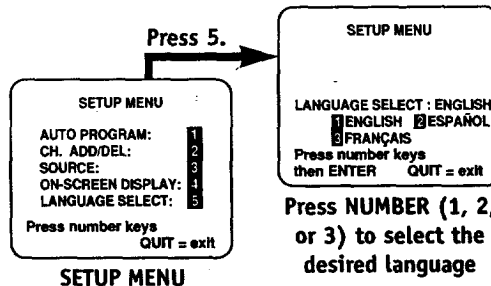

Some things you must do and others you may want to do before you can operate your VCR

Before you operate your VCR

5

Set Date and Time for Clock (Required) Set the clock in the VCR to the current date and time. See CLOCK Menu for details.



You must set the clock before you can use any timer-controlled VCR features, for example, TIMER recordings.

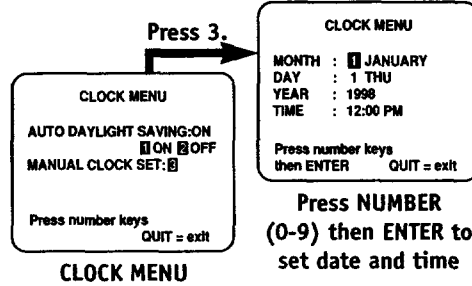

6

Select Source for VCR (Optional) Set the source of the VCR for the type of program signal you have connected to the ANT IN jack on the back of the VCR. Choose TV if you have an antenna connected to the VCR. Choose CATV if you have a cable system (with or without a cable box) connected to the VCR. Choose AUX if you have an accessory Audio/Video (A/V) connected to the VCR.

See SOURCE option on SETUP menu for details.

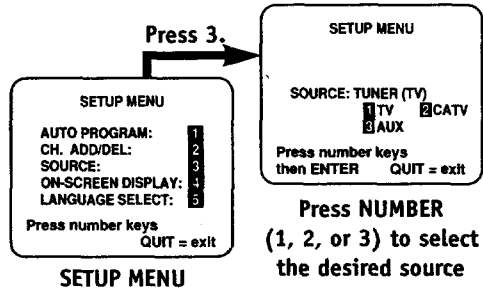

7

Use Auto Program to Find Channels (Required) Use AUTO PROGRAM to find active channels in your broadcast area. AUTO PROGRAM stores the active channels that you can access by using the Channel Up/Down arrows. See AUTO PROGRAM on the SETUP Menu for details.

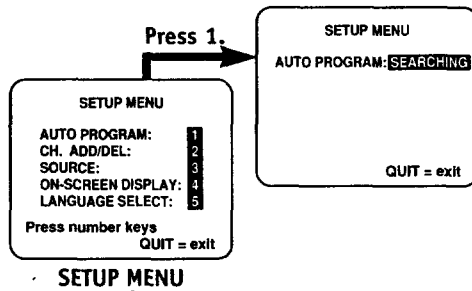

8

Use CH. ADD/DEL to Create Favorite Channels (Optional) Use CH. ADD/DEL to change the list of active channels found when using AUTO PROGRAM, so you can list your favorites. See CH.ADD/DEL on the SETUP Menu for details.

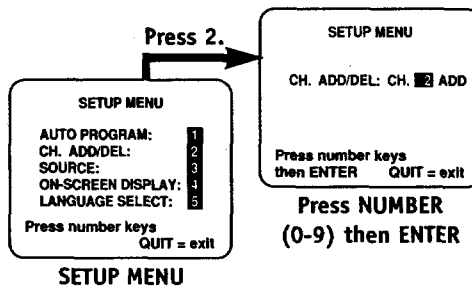

Before you operate your VCR

9

Select Other Menu Options

You may not want to have the clock in your VCR adjusted automatically for Daylight Saving Time. Refer to Clock Menu for details.

Things you may want to do before you operate your VCR.

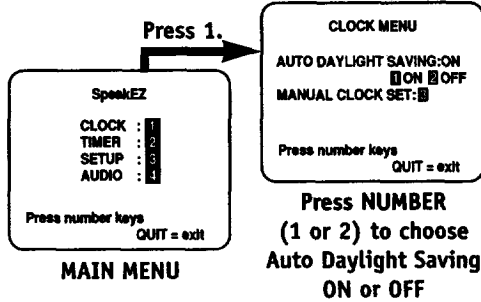

Show or hide the VCR status on your screen by using the ON-SCREEN DISPLAY option on the SETUP menu. We recommend keeping this option ON. See the SETUP menu for details.

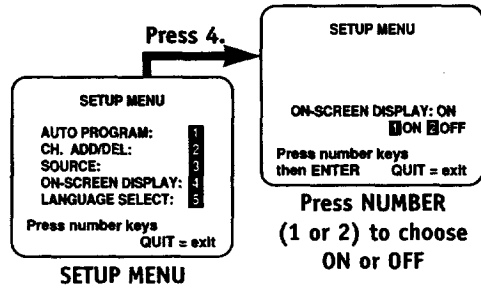

If you have a stereo VCR, select the audio format (HI-FI or NORMAL) to use when you play a tape. We recommend setting this option to HI-FI. See the PLAYBACK MODE option on the AUDIO Menu for details.

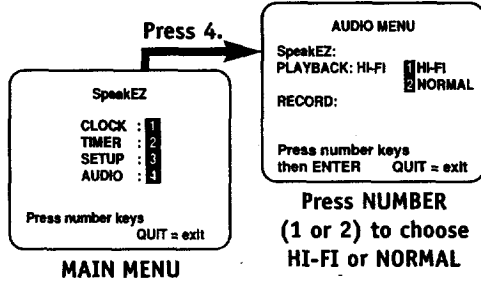

If you have a stereo VCR, select the audio format (STEREO, MONO or SAP) to use when recording. We recommend using STEREO. See the RECORD MODE option on the AUDIO Menu for details.

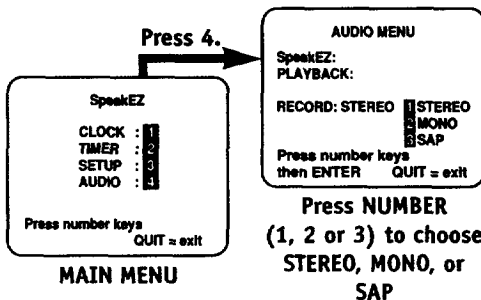

Front Panel Diagram

Descriptions of items you need to know to operate your VCR.

Front Panel Controls

These controls perform basic VCR operations. The Remote performs basic as well as advanced VCR operations.

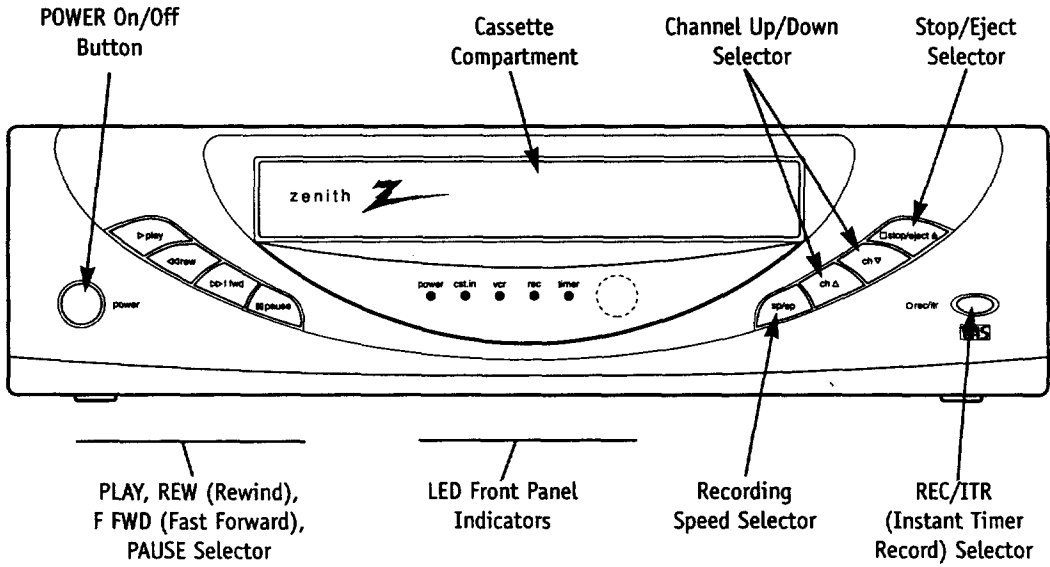

LED Front Panel Indicators

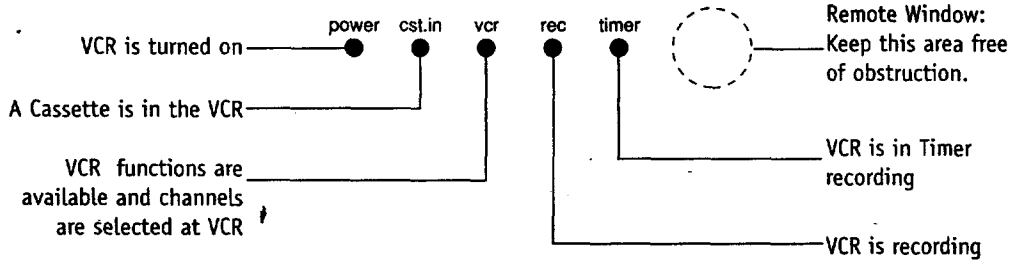

VCR Status Displays

On-Screen displays tell you the status of the tape inserted and VCR functions.

Current mode of operation (STOP, PAUSE, RECORD, PLAY, etc.) and audio format of tape, where Play=HI-FI or NORMAL(No display)

Tape Speed
 EP=Extended Play
 LP=Long Play
 SP=Standard Play

Current date, day, and time

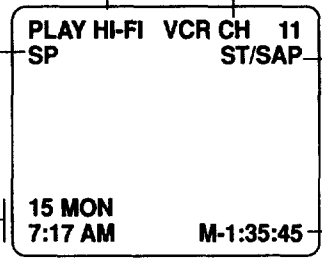

Current CH (Channel) selected by using tuner in VCR

Audio format of signal received by VCR tuner: STEREO, MONO or ST/SAP

Typical VCR Status Display on TV

Real-time tape counter
 M = Counter Memory is active
 - = Tape is rewound past index mark.
 1:35:45 = Length of tape (in time)
 1 = 1 hour
 35 = 35 minutes
 45 = 45 seconds

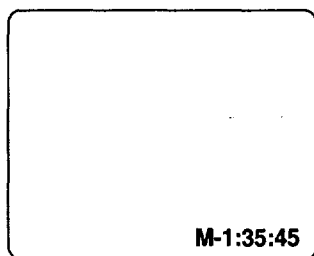

Tape Counter Position

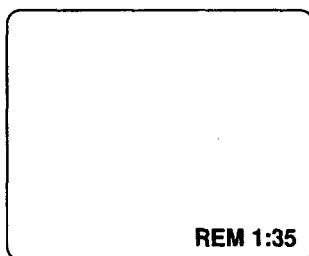

Tape Time Remaining

VCR Status Display

The VCR Status Display appears on the TV when a VCR function starts, like when you change a channel or select a different VCR mode. For example, pressing STOP while the VCR is in PLAY mode shows STOP in the display. Press ENTER on the remote at any time (except Special Effect Playback mode; SLOW, STILL etc.) to see the Status Display.

Note:

If the VCR Status Display does not appear on the TV screen, check the ON-SCREEN DISPLAY option on the SETUP menu. Select ON to see the display. See "VCR Menu Operations" section for details.

VCR Status Display Options

When the Status Display appears, press ENTER repeatedly to see abbreviated displays, as follows:

1. Press ENTER to see Status Display.
2. Press ENTER a second time to show only the tape counter position.
3. Press ENTER a third time to show only the tape time remaining.
4. Press ENTER repeatedly until all displays are removed.

The Buttons on Your Remote

A quick list of all the buttons on your remote control and what they do.

CH (▼/▲) — Changes favorite channel list. Also selects AUX A/V input channel.

CM SKIP — Fast forwards picture search through 30 seconds of recording.

EJECT — Ejects the tape in the VCR.

ENTER — Programs menu options and shows VCR display.

F FWD (Fast Forward) — Advances tape rapidly.

MEMORY — Returns real-time tape counter to zero (M 0:00:00).

MENU — Shows main menu.

Numbers — Chooses channels and enters programming information.

PAUSE — Pauses tape temporarily during playback or record.

PLAY — Begins tape playback.

POWER — Turns VCR On and Off. Also turns VCR Timer Off and On, if programmed.

QUIT — Exits menu system.

REC/ITR — Begins tape recording.

REW — Rewinds tape to the beginning.

SP/EP — Chooses tape recording speed.

STOP — Cancels playback or record modes.

TRACKING (▼/▲) — Adjusts tape playback tracking.

TV/VCR — Switches source of TV picture between TV channel and VCR channel selection. VCR functions are available in VCR mode.

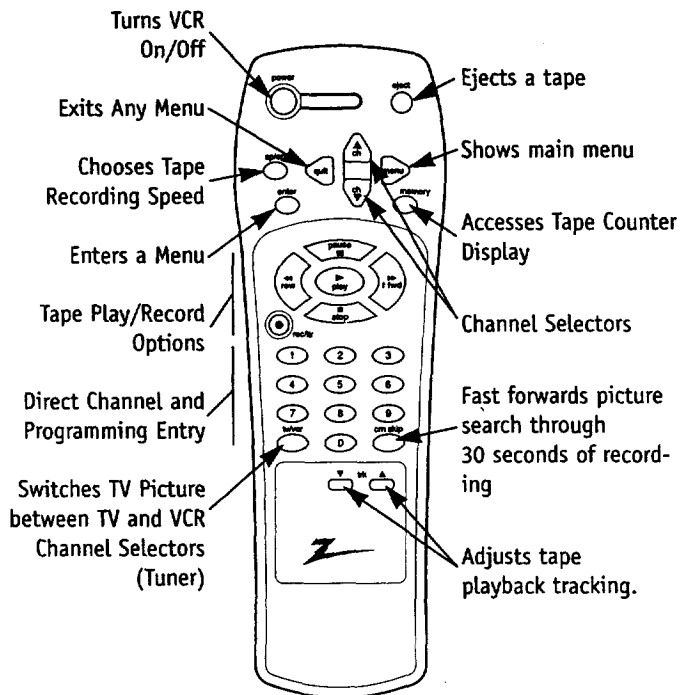

Installing Batteries

Be sure to install the batteries provided with this remote. Match positive (+) and negative (-) with markings shown in battery compartment.

Note: All VCR operations and menu options can be accessed by using the remote control.

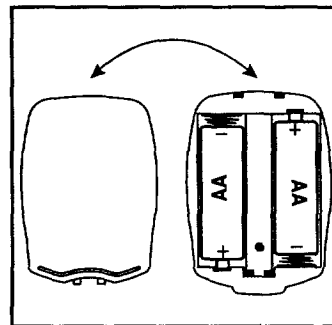

Main Menu

Introducing you to the Main Menu selections

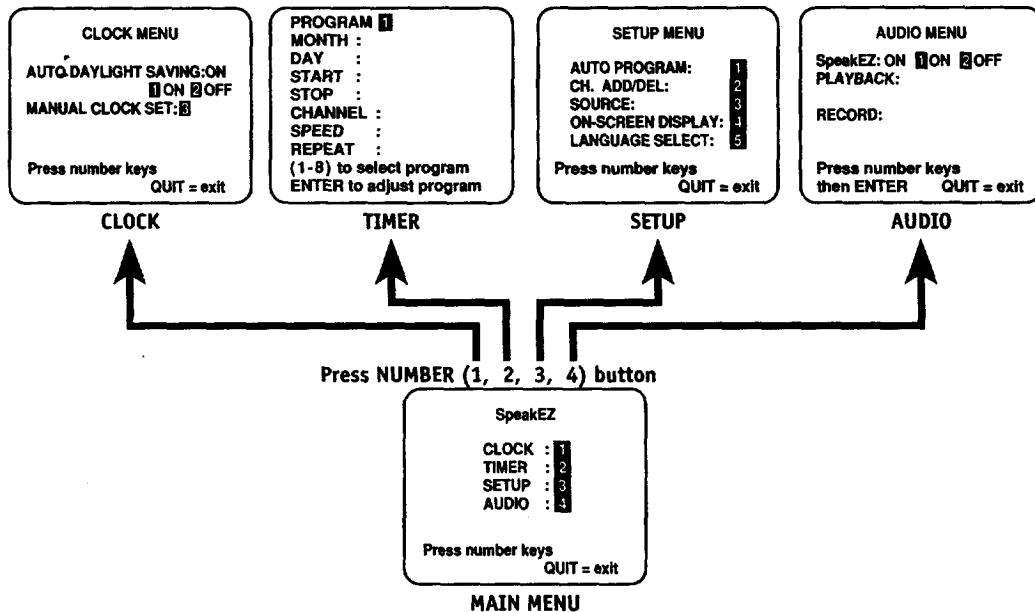

How to Access Menus

Menu operation is easy—just follow the instructions shown at the bottom of the menu.

1. Press MENU to see main menu.
2. Press NUMBER (1, 2, 3, or 4) to see desired sub menu to be used.
3. Press NUMBER to choose desired option to be changed.
4. Press QUIT to exit menu, or wait a few minutes and the VCR returns to normal operation.

Point remote toward VCR

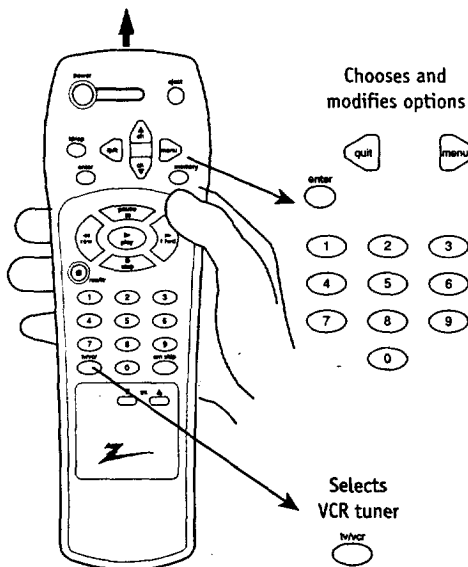

Note:

Perform menu operations with the VCR and TV on, and tune the TV to channel 3 or 4. The VCR must also be in the VCR mode of operation. Press TV/VCR repeatedly until VCR indicator appears in the front panel.

The Clock Menu sets the clock in VCR to the current time.

Clock Menu

How to Access Auto Daylight Saving

This VCR can adjust the clock automatically for Daylight Saving Time.

1. Press MENU to see Main Menu.
2. Press 1 to see Clock Menu on the Main Menu.
3. Press 1 to choose ON on the Clock Menu.

Note:

We recommend that you set the clock using the MANUAL method the first time you use your VCR. See MANUAL option for details.

```

CLOCK MENU
AUTO DAYLIGHT SAVING:ON
                     [1] ON [2] OFF
MANUAL CLOCK SET:[3]
Press number keys
                     QUIT = exit
  
```

Manual Clock Set

The CLOCK Menu sets the clock in the VCR to the current date and time.

Notes:

The clock must be set before you can record by using the TIMER menu.

You may have to reset the clock if a power outage lasts for more than 3 seconds.

```

CLOCK MENU
MONTH : [1] JANUARY
DAY   : 1 THU
YEAR  : 1998
TIME  : 12:00 PM
Press number keys
then ENTER   QUIT = exit
  
```

Typical CLOCK Menu with date and time settings

How to Set Clock

1. Press MENU to see Main Menu.
2. Press 1 to see clock options.
3. Press 3 to adjust your options.
4. Press the NUMBER (0-9) then ENTER to specify current date and time.
5. Press QUIT to exit the menu system.

Timer Menu

You can specify eight different events to be recorded in a one-year period.

The **TIMER** Menu tells the VCR when to record a program on a day and at a time you specify

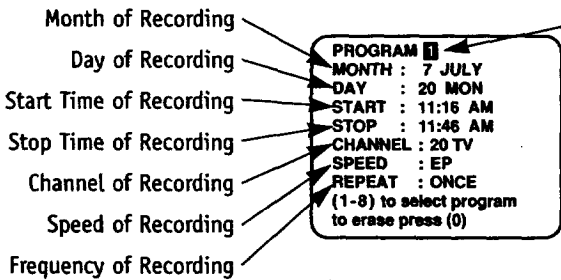
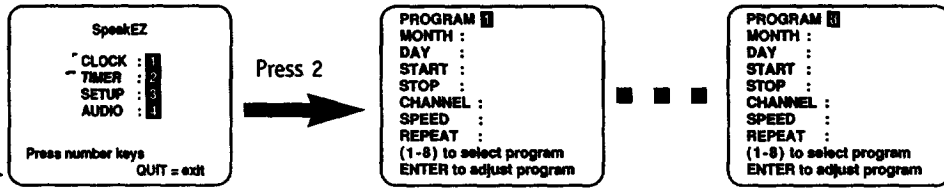

Program Number
When highlighted, press NUMBER (1-8) to choose program Number.

REPEAT OPTIONS
ONCE — Records once.
WEEKLY — Records once each week.
DAILY — Records one time each day, Monday - Friday.

CHANNEL OPTIONS
To select an AUX channel, select the next highest or lowest channel programmed in the VCR with the CHANNEL Up/Down arrows.

SPEED OPTIONS (SP or EP)
The SP mode determines how much tape is left and switches speed from SP to EP, if necessary, to complete recording the program. There will be some picture and sound distortion at the point of the speed change.

How to Use Timer

1. Choose **TIMER** menu as described in "How to Access Menus."
2. Press NUMBER(0-9) then **ENTER** to set the timer.
3. Press **QUIT** to exit the menu system.

Note:

Set the VCR in **TIMER** mode by pressing **POWER** to turn off the VCR. The **TIMER** indicator appears in the front panel of the VCR.



You cannot operate the VCR manually while it is recording. Pressing **POWER** stops the recording.

To Erase a Program

1. Choose **TIMER** menu as described in "How to Access Menus."
2. Press NUMBER(1-8) to select desired **PROGRAM** to be erased.
3. Press 0 to erase the program.
4. Press **QUIT** to exit the menu system.

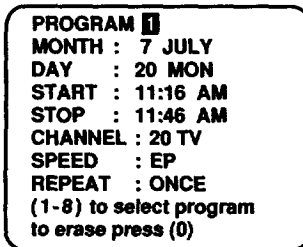

Press 0 to erase program

Setup Menu

The SETUP Menu customizes the VCR's operation for your particular needs.

Choose SETUP Menu as described in "How to Access Menus."

SETUP MENU

AUTO PROGRAM: 1
 CH. ADD/DEL: 2
 SOURCE: 3
 ON-SCREEN DISPLAY: 4
 LANGUAGE SELECT: 5

Press number keys
 QUIT = exit

AUTO PROGRAM	Finds all active channels and stores them in the VCR's memory for access by Channel Up/Down. Press 1 to begin search.
CH. ADD/DEL	Edits the channels found by AUTO PROGRAM. Use number keys followed by ENTER to select the channel to be edited (e.g., to ADD channel 3, press 3 then ENTER). Press ENTER to ADD or DEL (Delete) channels to create your own list of favorite channels.
SOURCE	Selects TV, CATV, or AUX as the source of the program to watch or record. Choose TV if you have an antenna connected to the VCR. Choose CATV if you have a cable system (with or without a cable box) connected to the VCR. Choose AUX if you want to see the program from accessory equipment, such as a camcorder, connected to the Audio/Video (A/V) IN jacks on the VCR.
ON-SCREEN DISPLAY	Selects whether or not you see VCR Status Displays on the TV.
LANGUAGE SELECT	Selects English, Spanish or French for VCR menus and displays on the TV.

Audio Menu

The AUDIO Menu indicates the audio format used when recording or playing a tape. Choose AUDIO Menu as described in "How to Access Menus."

Press **ENTER** (and repeat) to choose items in the menu (some models).

AUDIO MENU

SpeakeZ: ON ON OFF

PLAYBACK:

RECORD:

Press number keys then **ENTER** **QUIT = exit**

AUDIO Menu's **PLAYBACK** and **RECORD** options are available only with stereo VCRs.

SpeakeZ	Turns SpeakeZ ON or OFF. A voice tells you how to use the features you select in the menus if SpeakeZ is ON. (ON is recommended.)
PLAYBACK	Selects HI-FI or NORMAL for tape playback. HI-FI (High Fidelity) provides stereo sound, if present on the tape, to the left and right VCR AUDIO output jacks on the back of the VCR. NORMAL provides monaural sound, regardless of the audio format present on the tape.
RECORD	Select the STEREO, MONO, or SAP for recording a program. STEREO records sound from the left and right audio tracks in stereophonic format. MONO (Monaural) records sound in monaural format even if the program is in stereo. SAP records the Second Audio Program (SAP) track, if present, in addition to the stereo audio tracks. SAP usually contains audio in another language.

Watching TV Through the VCR

This page shows a typical video system and explains how to select channels.

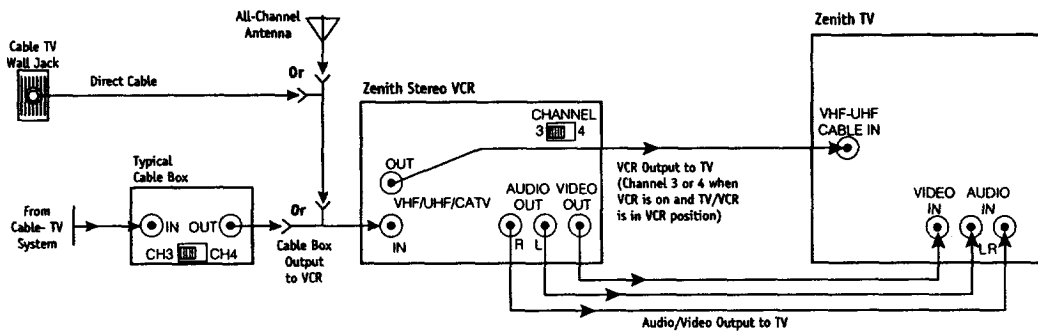

Selecting Channels when the VCR is OFF

1. Turn TV on.
2. Select channel you'd like to watch at the TV. If you have a cable box, select channel 3 or 4 at the TV. Selects cable box channels at the cable box.

Selecting Channels at the TV when VCR is ON

1. Turn TV and VCR on.
2. Place VCR in TV mode by pressing TV/VCR on the remote repeatedly until the VCR indicator disappears from the VCR front panel.
3. Select channel you'd like to watch at the TV. If you have a cable box, select channel 3 or 4 at the TV. Select cable box channels at the cable box.

Selecting Channels at the VCR when VCR is ON

1. Turn TV and VCR on.
2. Place VCR in VCR mode by pressing TV/VCR on remote repeatedly until the VCR indicator appears in the VCR front panel.
3. Select channels 3 or 4 at the TV. If you have connected your VCR to the TV's A/V input jacks, select the A/V source at the TV for a better picture.
4. Select the channel you'd like to watch at the VCR. If you have a cable box, select channel 3 or 4 at the VCR. Select cable box channels at the cable box.

Camcorder Connected to VCR

This page describes how to connect a camcorder to your VCR.

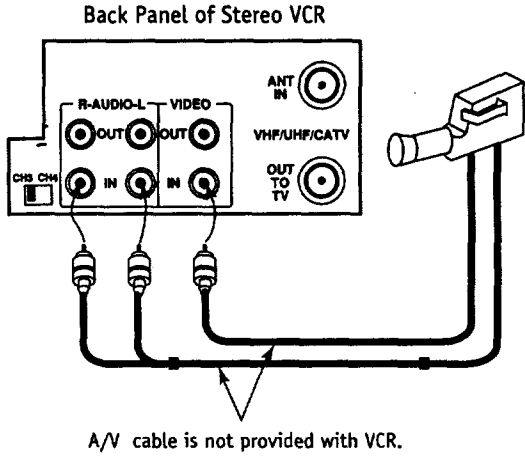

! Turn off power or unplug VCR before making any connections.

Select AUX for Viewing an Audio/Video source like a Camcorder

1. With TV and VCR on, place VCR in VCR mode by pressing TV/VCR on the remote (and repeat) until the VCR indicator appears in the VCR's front panel.
2. Select channel 3 (or 4) on the TV. Note: If your TV has A/V jacks, you may get a better picture if you connect your VCR there. (Then, select the A/V source on the TV.)
3. At the VCR, Channel Down lower than the lowest channel (or Channel Up above the highest) to select "AUX" Or, you may - Choose the SETUP menu as described in "How to Access Menus." Press 3 for the SETUP menu's SOURCE item. Press 3 for AUX, then ENTER. (Press QUIT to exit.)

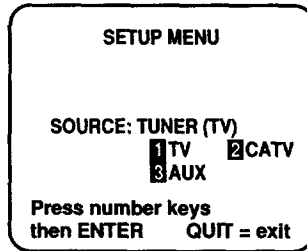

Press 3 to select AUX

Items in the Menu

SOURCE	Shows the program source—TV, CATV, or AUX—selected for the VCR to receive
TUNER	The VCR is using its Tuner to receive programs from an antenna or cable.
TV	Selects programs for the VCR from a rooftop-type antenna.
CATV	Selects programs for the VCR from Cable TV.
AUX	Selects programs for the VCR from the R-AUDIO-L—VIDEO IN jacks (where you may have connected your camcorder).

This page explains the basics of playing tapes in your VCR.

Playing Tapes

Automatic Playback (No Safety Tab)

1. Tape playback begins automatically, if the safety tab is removed from the cassette case. For example, most rental movies have no safety tab. Simply insert the prerecorded VHS cassette into the VCR. Power turns on and playback begins.
2. Select the channel 3 or 4 at the TV. Or, select the TV's AUX (Auxiliary) source to see the picture, if you are using the A/V jacks.

Manual Playback (Has Safety Tab)

1. Press POWER to turn VCR on.
2. Insert a prerecorded VHS cassette into the VCR.
3. Press PLAY to begin playback.
4. Select the channel 3 or 4 at the TV. Or, select the TV's AUX (Auxiliary) source to see the picture, if you are using the A/V jacks.

Unloading the Cassette from the VCR

1. Press STOP if the tape is playing.
2. Press STOP/EJECT at the VCR until the cassette is ejected.

Note:

This VCR records only in SP and EP speeds. Your VCR sets the playback speed automatically to the speed used to record the tape.



VCR's Controls

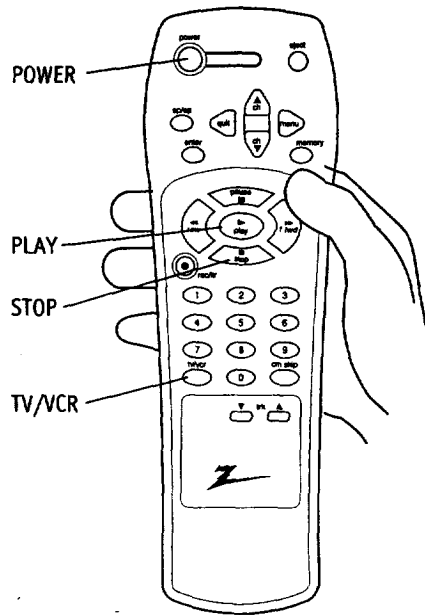
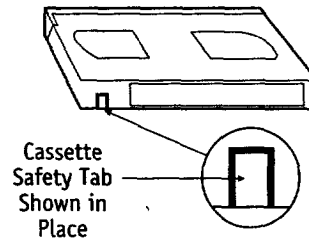

(Continued on next page)

VHS Cassette Playback/Record Times			
Cassette Length	SP (Standard Play)	LP (Long Play)	EP (Extended Play)
T-30	30 Minutes	1 Hour	1 Hour, 30 Minutes
T-60	1 Hour	2 Hours	3 Hours
T-120	2 Hours	4 Hours	6 Hours
T-160	2 Hours, 40 Minutes	5 Hours, 20 Minutes	8 Hours

Playing Tapes

This page explains how to use the remote to play tapes on your VCR.

Auto/Manual Tracking Adjustment

Your VCR adjusts tracking automatically when you play a tape. If the tape was recorded on a different VCR, streaks (video noise) may appear. While the tape is playing, press TRACKING (▼/▲) to adjust the tracking manually.

Real-Time Tape Counter

Press ENTER twice to keep the tape counter on the TV screen. Press ENTER repeatedly to remove all displays. The counter resets to 0:00:00 when you insert a cassette or when a tape is rewound to its beginning.

Pause/Forward/Reverse Slow-Motion Video

(While in play mode) Press PAUSE for still video. Press PAUSE again, and follow on-screen instructions for Forward or Reverse slow motion. Press F FWD or REW to control slow speed during slow motion. Press PLAY to resume normal tape playing.

Note: When the reverse slow mode continues for more than 30 seconds, the VCR will automatically change to play mode.

Tape Rewind and Fast Forward

(While in Stop mode) Press and release REW or F FWD (Fast Forward), as desired. Press STOP when tape reaches desired location.

Reverse/Forward Search

(While in Play mode) Press and release REW or F FWD, as desired. Press PLAY to resume normal tape playing.

CM Skip (Commercial Skip)

(While in play mode) Pressing CM SKIP on the remote skips commercials or other program material. Pressing 1, 2, 3, or 4 times skips 30, 60, 90, or 120 seconds, respectively. CM SKIP skips a full 120 seconds of commercials in a few seconds, then resumes normal playback.

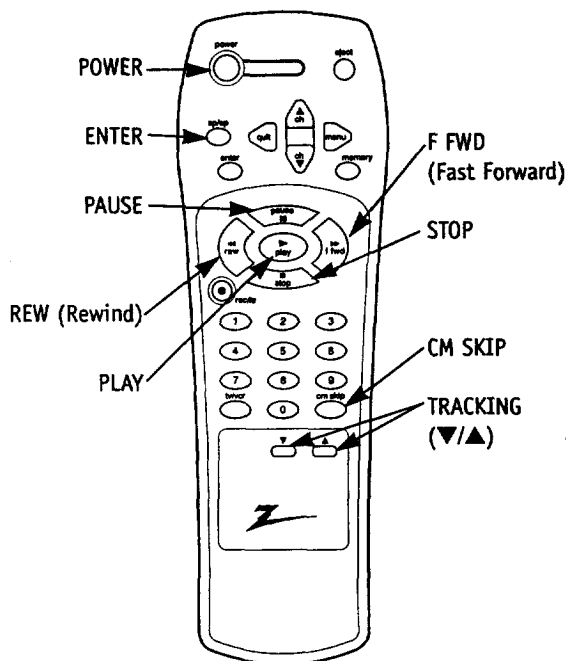

Recording what you are watching on TV.

Instant Recording

Options You Can Use While Recording

Instant recording lets you record until you reach the end of tape or you press STOP to stop recording.

1. Turn TV and VCR on.
2. Place VCR in VCR mode by pressing TV/VCR on the remote repeatedly until the VCR indicator appears in the VCR front panel.
3. Select channel 3 or 4 at the TV. If you have connected your VCR to the TV's A/V input jacks, select the A/V source at the TV for a better picture.
4. Select the channel to be watched and recorded at the VCR. If you have a cable box, select the cable box output channel (usually 3 or 4) at the VCR. Select cable box channels at the cable box.
5. Insert a VHS cassette tape into the VCR.
6. Press SP/EP to select recording speed, if desired. Recording speed is always SP, unless you select EP.
7. Press REC/ITR until recording begins. REC indicator appears in the VCR front panel. Recording continues until you reach the end of the tape, or until you press STOP to stop recording.

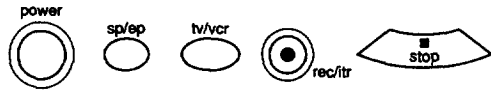

Remote's Controls



VCR's Controls

Instant Recording (until end of tape)	Instant Timer Recording (Preset recording times)
PAUSE - Momentarily Pauses recording. Press PAUSE again to resume recording.	STOP or STOP/EJECT - Stops and exits recording mode.
STOP or STOP/EJECT - Stops and exits recording mode.	

Instant Recording

Recording using preset time periods.

Preset Time Periods for ITR Recording.

Note:

Preset recording time counts down until the recording time is over.

Instant (attended) Timer Recording (ITR) lets you record where you record for a specific preset time period, instead of recording until the end of tape is reached. For example, you can record a 30-minute show using the preset time period.

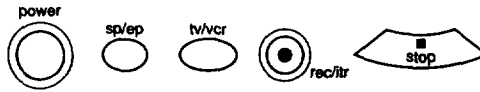

Remote's Controls



VCR's Controls

1 Turn TV and VCR on.

2 Place VCR in VCR mode by pressing TV/VCR on the remote repeatedly until the VCR indicator appears in the VCR front panel.

3 Select channel 3 or 4 at the TV. If you have connected your VCR to the TV's A/V input jacks, select the A/V source at the TV for a better picture.

4 Select the channel to be watched and recorded at the VCR. If you have a cable box, select the cable box output channel (usually 3 or 4) at the VCR. Select cable box channels at the cable box.

5 Insert a VHS cassette tape into the VCR.

6 Press SP/EP to select recording speed, if desired. Recording speed is always SP, unless you select EP.

7 Press REC/ITR until recording begins. The REC indicator appears in the VCR front panel. Recording continues until you reach the end of the tape, or until you press STOP to stop recording.

8 Press REC/ITR repeatedly to select a preset recording time period. Each subsequent press of REC/ITR increases the recording time by 30 minutes until you reach a maximum of 4 hours.

Presses of REC/ITR	Display	Preset Time For Recording
1 (Press)	Current Time	Until end of tape
2	0:30	30 minutes
3	1:00	1 hours
4	1:30	1 hour and 30 minutes
5	2:00	2 hours
.	.	.
9	4:00	4 hours
10	No display	normal recording

Note: The SP mode determines how much tape is left and switches speed from SP to EP, if necessary, to complete recording the program. There will be some picture and sound distortion at the point of the speed change.

Recording one show while watching another.

Instant Recording

Note:

If you have a cable box connected to your VCR, you cannot record one show and watch another.

Choose the show you wish to record using the VCR's channel selector. Choose the show you wish to watch using the TV's channel selector.

- 1** Turn TV and VCR on.
- 2** Place VCR in VCR mode by pressing TV/VCR on the remote repeatedly until the VCR indicator appears in the VCR front panel.
- 3** Select channel 3 or 4 at the TV. If you have connected your VCR to the TV's A/V input jacks, select the A/V source at the TV for a better picture.
- 4** Select the channel to be watched and recorded at the VCR. If you have a cable box, select the cable box output channel (usually 3 or 4) at the VCR. Select cable box channels at the cable box.
- 5** Insert a VHS cassette tape into the VCR.
- 6** Press SP/EP to select recording speed, if desired. Recording speed is always SP, unless you select EP.
- 7** Press REC/ITR until recording begins. REC indicator appears in the VCR front panel. Recording continues until you reach the end of the tape, or until you press STOP to stop recording.
- 8** Place VCR in TV mode by pressing TV/VCR on remote to turn off VCR indicator in the VCR front panel.
- 9** Select the show you wish to watch using the TV's channel selector.

Note:

To return to the show you're recording, select channel 3 or 4 at the TV. Place the VCR in the VCR mode by pressing TV/VCR on the remote to show the VCR indicator in the VCR's front panel.

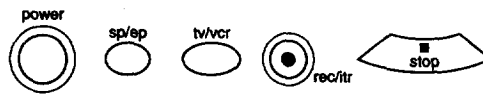

Remote's Controls



VCR's Controls

Options You Can Use While Recording

Instant Recording (until end of tape)
PAUSE - Momentarily pauses recording. Press PAUSE again to resume recording.
STOP or STOP/EJECT - Stops and exits recording mode.

Recording While You're Away

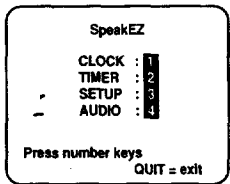

MAIN MENU

Press 2

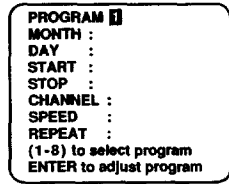

**TIMER MENU
for Program 1**

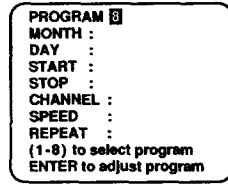

**TIMER MENU
for Program 8**

This page explains how to use the timer so that you can record while you are away.

Timer-controlled recording lets you record shows unattended. Pick a day and time up to one year in advance. The show may be recorded once or on multiple days. You can schedule up to eight different events into the PROGRAM TIMER for recording, as long as no events overlap in the same time period.

VCR Operation with Timer Off or On

VCR POWER	TIMER STATUS	VCR OPERATION
On	Off	Disables timer-controlled recording if an event is Scheduled in the Timer. All other VCR operations can be used as desired.
Off	On (or set)	Enables timer-controlled recording if an event is scheduled in the Timer. You cannot operate the VCR manually while it is in Timer Set mode. If you have scheduled the Timer, you'll be recording at a later time.

- 1** Turn TV and VCR on.
- 2** Place VCR in VCR mode by pressing TV/VCR on the remote repeatedly until the VCR indicator appears in the VCR front panel.
- 3** Select channel 3 or 4 at the TV.
- 4** Insert a VHS cassette tape into the VCR.
- 5** Program events to be recorded with the Timer by following the procedure in the TIMER MENU section. If you have a cable box, select channel 3 or 4 (or the VCR) as the channel to be recorded. Keep your cable box on when using the Timer to record.
- 6** Enable the Timer by pressing POWER to turn off the VCR. The TIMER indicator appears in the VCR front panel to indicate the VCR is in the TIMER recording mode.

Some quick and easy tips to fixing problems yourself.

Troubleshooting

Before Calling for Service

Please refer to this chart before calling for service. First, turn on the TV and VCR. Select appropriate input for the TV to receive the video signal from the VCR. You will probably use the Antenna In connection to the TV. Select channel 3 or 4 at the TV. Place the VCR in the VCR mode by pressing TV/VCR on the remote repeatedly until VCR indicator appears in the VCR front panel. If you have a cable box, turn it on and select channel 3 or 4 at the VCR.

Operating Problems		
Observed Condition	Possible Cause	Probable Solution
No power to the VCR.	Power cord is not connected.	Connect power cord.
Remote does not function.	Batteries are weak.	Replace with new batteries.
	You are too far away from the VCR.	Move closer to the VCR.
	Remote may be at an awkward angle.	Avoid holding the remote at sharp angle.
No picture appears on TV screen from any VCR function.	Source for TV is not selected properly.	Set INPUT source on TV to Audio/Video In, or tune TV to Channel 3 or 4, as appropriate.
	TV/VCR mode for VCR is set to TV.	Press TV/VCR on remote repeatedly to choose VCR mode. VCR indicator appears in VCR front panel.
VCR features do not function. VCR does not respond to remote functions or VCR keys.	VCR is locked up	Disconnect VCR power cord for three (3) seconds. Reset clock and other features as necessary.

Playing Tapes (Playback) Problems		
Observed Condition	Possible Cause	Probable Solution
Tape will not rewind or fast forward.	Tape is fully rewound or is at its end.	No action necessary.
Mechanical sound is audible during playback.	Note: This is normal operating sound from internal mechanisms.	No action necessary.
Tape playback does not appear on TV screen.	Source for TV is not selected properly.	Set Input source on TV to Audio/Video In, or tune TV to Channel 3 or 4, as appropriate.
	TV/VCR mode for VCR is set to TV.	Press TV/VCR repeatedly to choose VCR mode. VCR indicator appears in VCR front panel.
Video "noise" (horizontal streaks) appear during normal tape playing.	Tape is a rental or was recorded on another VCR.	Use TRACKING (▼/▲) for manual tracking adjustment while tape is playing.
	Tape heads are dirty.	Clean video heads.
VCR Status Display flickers when using STILL video during tape playback.	Tape tracking needs to be adjusted while in slow-motion playback.	From STILL video mode, enable slow-motion playback. Use TRACKING (▼/▲) to adjust tracking for best picture. Return to PLAY mode, then press PAUSE for STILL video.

Troubleshooting

Some quick and easy tips to fixing problems yourself.

Channel Tuning Problems		
Observed Condition	Possible Cause	Probable Solution
Some channels are skipped over when using Channel Up/Down.	Those channels were deleted with the CH. ADD/DEL option.	Use CH. ADD/DEL to restore channels. See SETUP Menu for details.
Picture and sound are weak or missing.	Antenna or cables are loose.	Tighten connections or replace cable.
	Wrong SOURCE option is being used.	Try all SOURCE options. See SETUP menu for details.

Recording Problems		
Observed Condition	Possible Cause	Probable Solution
Camcorder image is not shown.	Camcorder is off.	Turn camcorder on and operate properly.
Camcorder image via A/V input to VCR is not shown on TV screen.	VCR SOURCE is not set to AUX.	Use Channel Up/Down to select AUX A/V input channel.
Timer recording is not possible.	Clock in VCR is not set to correct time.	Set clock to correct time. See CLOCK menu.
	VCR is on which disables timer.	Turn VCR off to enable timer. TIMER indicator appears in the VCR front panel.
	Timer has been programmed incorrectly.	Reprogram Timer. See TIMER menu.
	TIMER indicator does not appear after programming timer.	Reprogram Timer and turn VCR off to enable timer.
TIMER indicator appears after VCR is turned off.	VCR is in Timer Recording mode.	This is normal indication that the VCR is in TIMER mode. If needed, disable TIMER by turning VCR on.

Stereo Audio Record and/or Playback Problems		
Observed Condition	Possible Cause	Probable Solution
Stereo is not present.	TV is not Stereo-compatible.	No action is possible.
	Program is not in stereo format.	No action is possible.
	VCR A/V Out jacks are not connected to TV A/V In jacks.	Make A/V connections. Stereo is available only via A/V output from VCR.
	VCR Audio/Video Out is not selected for viewing at the TV.	Select AUX or A/V source as TV input.
	VCR AUDIO RECORD mode is set to SAP or MONAURAL.	Set VCR AUDIO RECORD mode to Stereo. See AUDIO Menu.

Some quick and easy tips to fixing problems yourself.

Troubleshooting

Moisture Condensation	
Moisture condensation can occur:	In locations where moisture condensation may occur:
<ul style="list-style-type: none"> • When the video recorder is moved from a cold place to a warm place. • Under extremely humid conditions 	<ul style="list-style-type: none"> • Keep the power cord plugged into an AC outlet and POWER On. This will help prevent condensation. • When condensation has occurred, wait a few hours for the VCR to dry before using it.

Magnetic Field from Other Equipment

Keep the VCR and videotapes away from strong magnetic fields, such as those produced by a vacuum cleaner, refrigerator, or air conditioner.

Video Head Cleaning

Your VCR automatically cleans the heads as it is used. However, after long periods of use, your video heads may become clogged with accumulated dirt, causing distortion. When this occurs, use a do-it-yourself wet-type head cleaning cassette available from your Zenith dealer.

Caution:

Do not use a dry-type head cleaning system. It may seriously damage the VCR and cassettes used in the VCR. Snow, streaking in picture, and horizontal pulling indicate the need for professional video head cleaning. See your Zenith approved service center for cleaning.

Cabinet Cleaning

Clean the outside surfaces of the VCR with a soft lint-free cloth as required. Use care not to scratch the VCR during cleaning.

Index

Find what you want quickly.

FEATURE	PAGE
Audio Menu	17
Auto Channel Search	8, 16
Connections	4-5, 19
Ch. Add/Del.	8, 16
Clock Set	8, 14
Features Chart	3
Front Panel Diagram	10
Instant Recording	22-24
Language Menu	16
Main Menu	13
Maintenance	28
Playing Tapes	20-21
Remote Control	12
Safety Information	2
Setup Menu	16
SpeakeZ Function	7
Timer Menu	15
Timer-Controlled Recording	25
Troubleshooting	26-28
VCR Status Displays	11
Warranty	32
Watching TV	18

Recommended Audio/Video Accessories

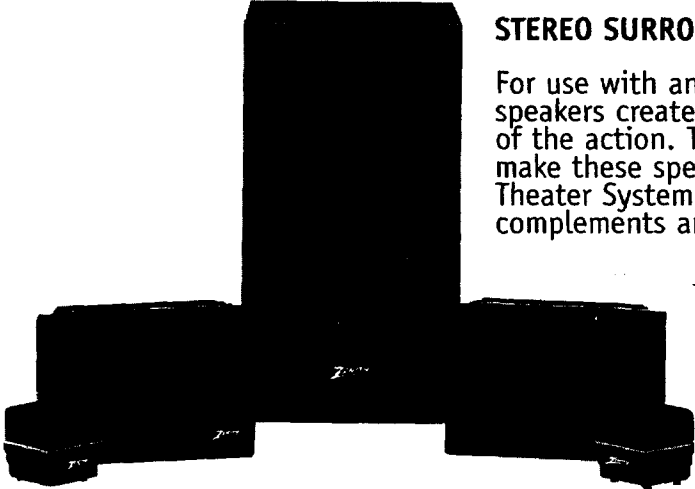

STEREO SURROUND SOUND SPEAKERS

For use with any Surround Sound compatible TV. These speakers create a sound so real, it's as if you were part of the action. The convenient, space-saving shelf design make these speakers an ideal addition to any Home Theater System. The contemporary black finish complements any room.

CV5000 ONLY \$224.95 PLUS \$17.95 SHIPPING & HANDLING

REPLACEMENT REMOTE

Broken or lost remote? Perhaps you would just like the convenience of having a second remote on hand. Order your replacement remote control direct from Zenith! To ensure that you receive the correct remote, have your television's model number ready when you call.

ONLY \$39.95 PLUS \$4.95 SHIPPING & HANDLING

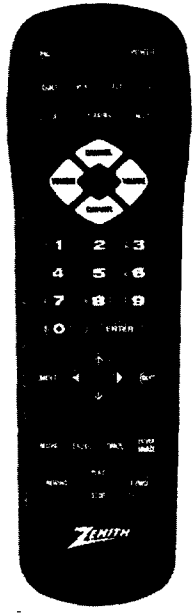

**ORDER TODAY!
CALL TOLL-FREE
1.800.255.6790**

zenith



Use Your Visa or MasterCard to Order
PLEASE ALLOW 3-4 WEEKS FOR DELIVERY

Notes

Use this page
to makes
notes.

Your Zenith Limited Warranty

VIDEO CASSETTE RECORDER OR PLAYER

Welcome into the Zenith family! We believe that you will be pleased with your new Zenith Entertainment Machine. Please read this warranty carefully, it is a "LIMITED WARRANTY" as defined under Federal Law. This warranty gives you specific legal rights, and you may also have other rights that vary from state to state within the U.S.A.

ZENITH'S RESPONSIBILITY

- Service Labor** During a period of 90 days from effective warranty date, Zenith will provide service labor by a Zenith authorized service center when needed as determined by Zenith, as a result of manufacturing defects.
- Parts** New or remanufactured replacements for factory-defective parts will be supplied by a Zenith authorized service center for one year from effective warranty date. Such replacement parts are warranted for the remaining portion of the original warranty period.
- Not Covered** This warranty covers manufacturing defects and does not cover installation, adjustment of customer controls in the home, installation or repair of home antenna systems, cable converters or cable company-supplied equipment; it also does not cover damage due to misuse, abuse, negligence, acts of God or other causes beyond the control of Zenith. Any alteration of the product after manufacture voids this warranty in its entirety.

OWNER'S RESPONSIBILITY

- Effective Warranty Date** Warranty begins on the date of original consumer purchase. For your convenience, keep the dealer's dated bill of sale or a delivery ticket as evidence of the purchase date.
- Operating Guide** Read your Operating Guide carefully so that you will understand the operation of your set and how to adjust the customer controls.
- Carry-In Service** The video product must be taken to a U.S. or Canadian Zenith authorized service center for warranty service and must be picked up by the owner.
- TV Set Performance** It is the owner's responsibility to maintain the TV receiver with which the video product is used, and the associated antenna system, in proper operating condition..
- Important** Product Registration—Please fill out and mail your Product Registration Card. It is imperative that Zenith know how to reach you promptly if we should discover a safety problem that could affect you.
- Warranty Service** For warranty service information, contact any Zenith authorized service center. Parts and service labor that are Zenith's responsibility (see above) will be provided without charge. Other service is at the owner's expense. If you have any problem in obtaining satisfactory warranty service, call or write the Zenith Response Center. You must provide the model number, serial number and date of purchase or date of original installation. Before you ask for warranty service, read "Maintenance And Troubleshooting" in your operating guide. You might avoid a service call.

THIS WARRANTY IS IN LIEU OF ANY OTHER WARRANTY, EXPRESS OR IMPLIED, INCLUDING WITHOUT LIMITATION, ANY WARRANTY OF MERCHANTABILITY OR FITNESS FOR A PARTICULAR PURPOSE, AND ZENITH SHALL NOT BE LIABLE FOR ANY CONSEQUENTIAL, INDIRECT, OR INCIDENTAL DAMAGES OF ANY KIND, INCLUDING LOST REVENUES OR PROFITS IN CONNECTION WITH THE PRODUCT.

**Zenith Electronics Corporation
Customer Service Department
1000 Milwaukee Avenue
Glenview, Illinois 60025-2493
Telephone: (847) 391-8752
Mon-Fri, 8:00 a.m. - 4:30 p.m. Central Time**