

# Panasonic

Multi Function  
Plain Paper FAX

## KX-F1050

Model No. **KX-F1070**

# OPERATING INSTRUCTIONS

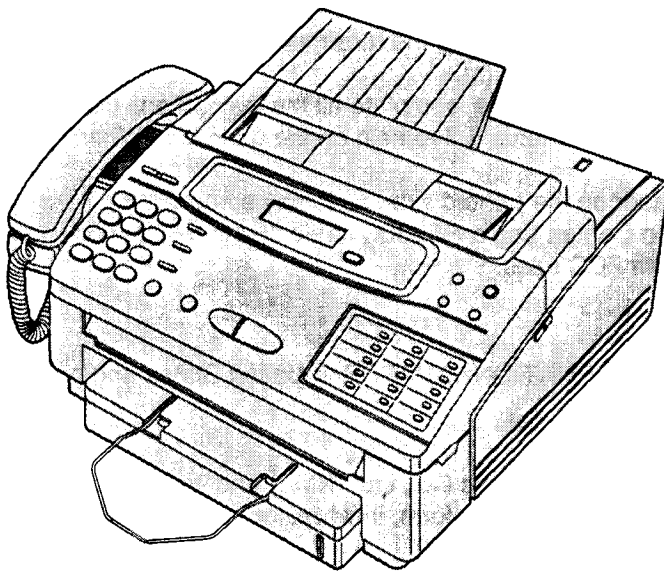

Please read these Operating Instructions before using the unit and save for future reference.

**FOR OPERATION ASSISTANCE,  
CALL 1-800-HELP-FAX**

- This product is designed for use in the United States of America, and may not operate in other countries. (See page 71 for more details.)
- Este producto ha sido diseñado para su uso en los Estados Unidos de América, y puede no funcionar correctamente en otros países. (Consulte la página 71 para tener más detalles.)

## Contents

---

Installation and Connection . . . . .	p. 6
Initial Preparation . . . . .	p. 14
Basic Operations . . . . .	p. 19
Advanced Operations . . . . .	p. 27
Troubleshooting and Routine Care . . . . .	p. 55
General Information . . . . .	p. 67

PFQX1052ZA

*Thank you for purchasing the Panasonic Plain Paper Facsimile.*

## Things you should keep records of

Attach your sales receipt here

### For your future reference

Date of purchase \_\_\_\_\_

Serial No. \_\_\_\_\_

(found on the rear of the unit)

Dealer's name and address \_\_\_\_\_

Dealer's telephone number \_\_\_\_\_

### Caution:

- The Telephone Protection Act of 1991 requires the following information to be clearly stated either at the top or bottom margin of the first message when transmitting messages via telephone facsimile;
  - Date and time of transmission,
  - Identification of the business, entity or person(s) sending the facsimile, and
  - Telephone number of the business, entity or person(s).To program this information into your facsimile machine, complete all the instructions on pages 14-16.
- Note that the images of copied or received documents will remain on the used film. When disposing of the used film, use discretion.
- Do not rub the printed side or use an eraser on the printed side, as it may smear.
- When using the Panasonic Multi Function Center, use a RS232C cable that is five feet or shorter for reliable data communications and compliance with FCC rules.

### Trademarks

Hammermill® is registered trademarks of INTERNATIONAL PAPER in United States and/or other countries.

### Copyright:

This manual is copyrighted by Kyushu Matsushita Electric Co., Ltd. (KME) and its licensee. Under the copyright laws, this manual may not be reproduced in any form, in whole or part, without the prior written consent of KME and its licensee.

© 1996 Kyushu Matsushita Electric Co., Ltd. All Rights Reserved.

## Using attached user guides

The unit performs the following functions; plain paper facsimile, copier, scanner, PC Fax, telephone and printer. To use this unit efficiently, we recommend you read the instructions below in the following order.

### Quick start guide

This guide summarizes installation and basic operations. To connect the KX-F1050/KX-F1070 to your computer, see the PC Connections and Installation for Multi Function Center section.

### Operating Instructions

This manual describes installation, initial preparation, how to use a facsimile, copy and telephone, troubleshooting, routine care and general information.

# Important safety instructions

When using this product, basic safety precautions should always be followed to reduce the risk of fire, electric shock, and injury to persons, including the following:

1. Read and understand all instructions.
  2. Follow all warnings and instructions marked on this product.
  3. Unplug this product from wall outlets before cleaning. Do not use liquid or aerosol cleaners. Use a damp cloth for cleaning.
  4. Do not use this product near water, for example, near a bath tub, wash bowl, kitchen sink, or laundry tub, in a wet basement, or near a swimming pool.
  5. Do not place this product on an unstable cart, stand or table. The product may fall, causing serious damage to the product.
  6. Slots and openings in the cabinet and the back or bottom are provided for ventilation, to protect it from overheating, these openings must not be blocked or covered. The openings should never be blocked by placing the product on the bed, sofa rug, or other similar surface. This product should never be placed near or over a radiator or heat register. This product should not be placed in a built-in installation unless proper ventilation is provided.
  7. This product should be operated only from the type of power source indicated on the marking label. If you are not sure of the type of power supply to your home, consult your dealer or local power company.
  8. This product is equipped with a three wire grounding type plug, a plug having a third (grounding) pin. This plug will only fit into a grounding type power outlet. This is a safety feature. If you are unable to insert the plug into the outlet, contact your electrician to replace your obsolete outlet. Do not defeat the safety purpose of the grounding type plug.
  9. Do not allow anything to rest on the power cord. Do not locate this product where the cord will be abused by people walking on it.
  10. Do not overload wall outlets and extension cords as this can result in the risk of fire or electric shock.
  11. Never push objects of any kind into this product through cabinet slots as they may touch dangerous voltage points or short out parts that could result in a risk of fire or electric shock. Never spill liquid of any kind on the product.
  12. To reduce the risk of electric shock, do not disassemble this product, but take it to a qualified serviceman when some service or repair work is required. Opening or removing covers may expose you to dangerous voltage or other risks.
- Incorrect reassembly can cause electric shock when the appliance is subsequently used.
13. Unplug this product from the wall outlet and refer servicing to qualified service personnel under the following conditions:
    - A. When the power supply cord or plug is damaged or frayed.
    - B. If liquid has been spilled into the product.
    - C. If the product has been exposed to rain or water.
    - D. If the product does not work normally by following the operating instructions. Adjust only those controls, that are covered by the operating instructions because improper adjustment of other controls may result in damage and will often require extensive work by a qualified technician to restore the product to normal operation.
    - E. If the product has been dropped or the cabinet has been damaged.
    - F. If the product exhibits a distinct change in performance.
  14. Avoid using a telephone (other than a cordless type) during an electrical storm. There may be a remote risk of electric shock from lightning.
  15. Do not use the telephone to report a gas leak in the vicinity of the leak.

## SAVE THESE INSTRUCTIONS

### INSTALLATION:

1. Never install telephone wiring during a lightning storm.
2. Never install telephone jacks in wet locations unless the jack is specifically designed for wet locations.
3. Never touch uninsulated telephone wires or terminals unless the telephone line has been disconnected at the network interface.
4. Use caution when installing or modifying telephone lines.

### WARNING:

To prevent the risk of fire or electrical shock, do not expose this product to rain or any type of moisture.

### OTHER INFORMATION

- Keep the unit away from electrical noise-generating devices, such as fluorescent lamps and motors.
- The unit should be kept free from dust, moisture, high temperature, and vibration.
- The unit should not be exposed to direct sunlight.
- Do not place heavy objects on top of this unit.
- Do not damage the power cord.
- Do not touch the plug with wet hands.
- Do not use benzene, thinner, or any abrasive powder, to clean the cabinet. Wipe it with a soft cloth.

# Table of Contents

## Installation and Connection

Included accessories .....	6
Location of controls .....	7
Installing your unit .....	9
Connections .....	13

## Initial Preparation

Setting the date, time, logo and facsimile telephone number .....	14
Adjusting volumes .....	16
Selecting the receive mode .....	17

## Basic Operations

Making voice calls .....	19
Answering voice calls .....	19
Transmitting documents .....	20
Receiving documents .....	22
Making a copy .....	26

## Advanced Operations

### *Automatic dialing*

Storing phone numbers for automatic dialing .....	27
Making voice calls using automatic dialing .....	28
Transmitting documents using automatic dialing .....	28
Electric telephone directory .....	29

### *Telephone*

Voice contact (talking to the caller during or after fax reception or transmission) .....	30
TONE, FLASH and REDIAL/PAUSE buttons .....	31

### *Special sending features*

Polling (retrieving fax documents) .....	32
Delayed transmission (sending a fax at a later time) .....	33
Sending documents overseas .....	34
Reserving transmission during fax reception .....	34
Printing a cover page .....	35

### *Special receiving features*

Remote fax receiving (using an extension phone to receive a fax message) .....	36
Junk mail prohibitor (preventing the reception of unwanted fax documents) .....	37
Receiving with distinctive ring service .....	38
Signaling your pager that you have received a fax document .....	39
Receiving documents in memory .....	40
Receiving oversized documents .....	42
Film/paper save reception .....	43

**Enhanced copy features**

Making an enlarged copy ..... 44  
 Making a reduced copy ..... 45

**Others**

Using an external telephone answering machine ..... 46  
 Changing the logo print position ..... 49  
 Changing the display contrast ..... 49  
 Resetting the advanced features ..... 50  
 Summary of user programmable features ..... 51  
 Printing reports and lists ..... 52

**Troubleshooting and Routine Care**



Error messages on the display ..... 55  
 Before requesting help ..... 56  
 Error codes on your PC when using Multi Function Center software ..... 58  
 If a power failure occurs... ..... 60  
 If a problem occurs during reception ..... 60  
 Clearing a recording paper jam ..... 61  
 Clearing a document jam ..... 63  
 Adjusting the feeder pressure ..... 63  
 Cleaning the inside of the unit ..... 64  
 Replacing the film or film cartridge ..... 65

**General Information**

FCC information ..... 67  
 Limited warranty ..... 68  
 Service center directory ..... 69  
 Information for users ..... 70  
 Accessory order information ..... 70  
 Specifications ..... 71  
 Speed dialer list ..... 73  
 Index ..... 75

# Included accessories

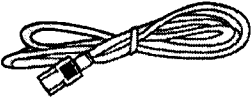
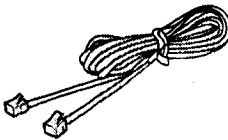
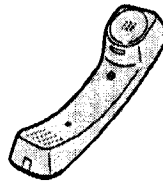
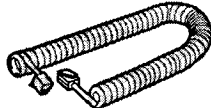
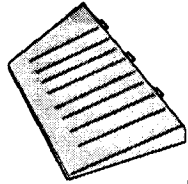
To order, call toll free 1-800-332-5368.

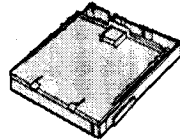
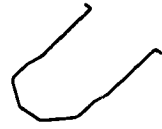
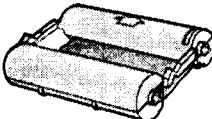
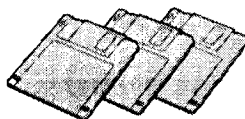
<p>Power cord ..... 1 pc. Part No.PQJA200Z</p>  <p>(p. 13)</p>	<p>Telephone line cord ..... 1 pc. Part No.PQJA59V</p>  <p>(p. 13)</p>	<p>Handset ..... 1 pc. Part No.PQJXD0105Z</p>  <p>(p. 13)</p>	<p>Handset cord ..... 1 pc. Part No.PQJA212M</p>  <p>(p. 13)</p>
<p>Document feeder tray ..... 1 pc. Part No.PQKS10011Y2</p>  <p>(p. 12)</p>	<p>Document stacker ..... 1 pc. Part No.PQZSF1000M</p>  <p>(p. 12)</p>	<p>Paper cassette ..... 1 pc. Cover:Part No.PFKV1002Z1 Tray:Part No.PFZEF1050M</p>  <p>(p. 9)</p> <p>—The paper cassette is pre-installed.</p>	<p>Paper stacker ..... 1 pc. Part No.PFUS1031Z</p>  <p>(p. 10)</p>
<p>Film cartridge ..... 1 pc.</p>  <p>(p. 65, 70)</p> <p>—The included film is 30 meters. —The film cartridge is pre-installed.</p>	<p>Panasonic Multi Function Center Software (Floppy disks) ..... 3 pcs. Part No.PFZXF1050M</p>  <p>(See Quick Start Guide.)</p>		

- If any items are missing or damaged, check with place of purchase.
- The part numbers listed above are subject to change without notice.
- Save the original carton and packing materials for future shipping and transporting of the unit.

## To use this unit with your PC

Prepare a RS232C cable (DB9 Female/DB25 Male).

RS232C (DB9 Female/DB25 Male) serial cables can usually be purchased at any computer store or computer supply store. If you need help finding the correct cable, call 1-800-HELP-FAX.

# Location of controls

## Front view

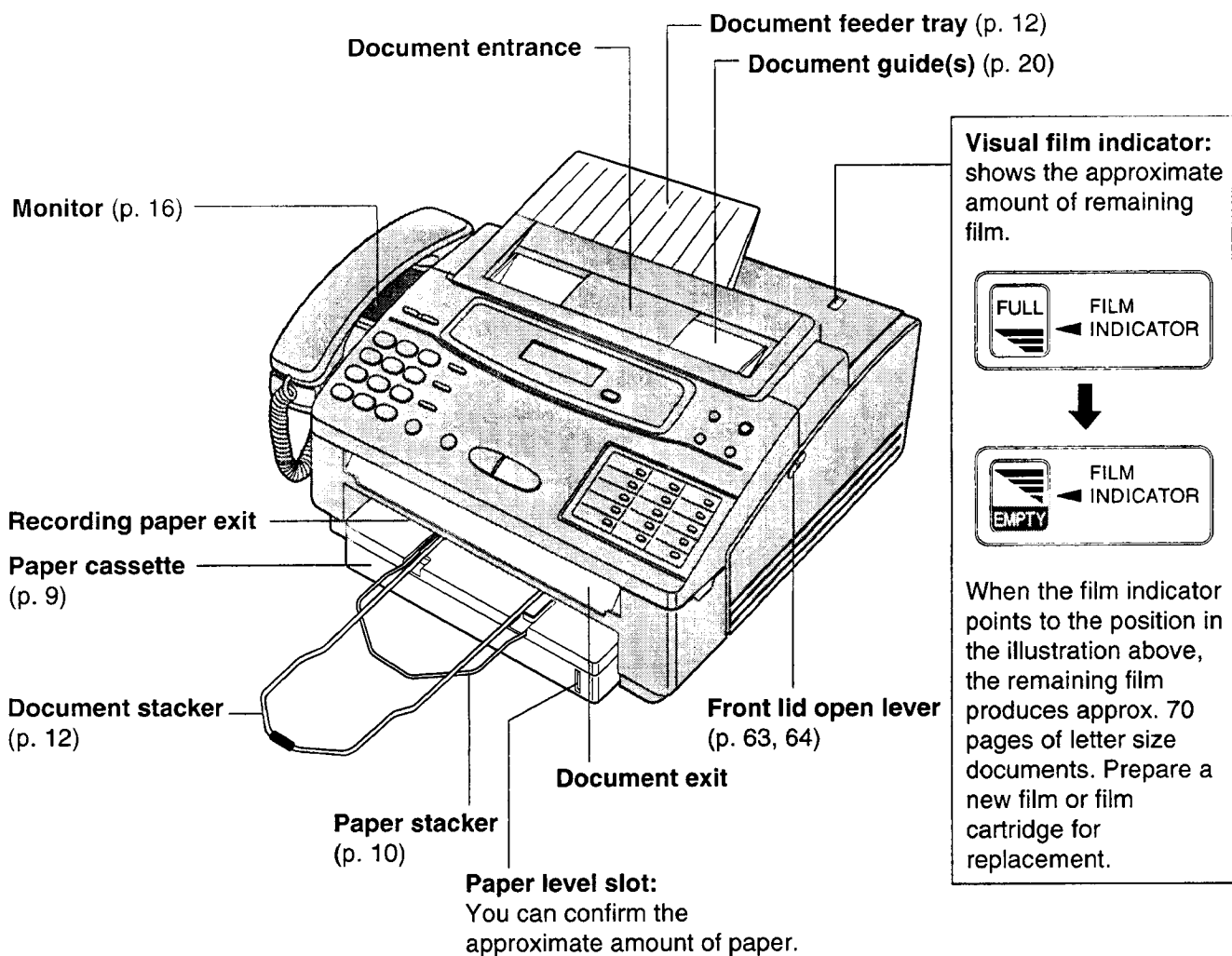

**Note:**

- The visual film indicator will show "FULL" when a new 200 meter (656') film is installed. When the supplied film cartridge, 30 meter roll film (100'), is installed, the indicator will not show "FULL".
- Because the length of the supplied film is 30 meters, it is recommended to purchase an additional 200 meter length film for replacement soon. See page 70.

# Control panel

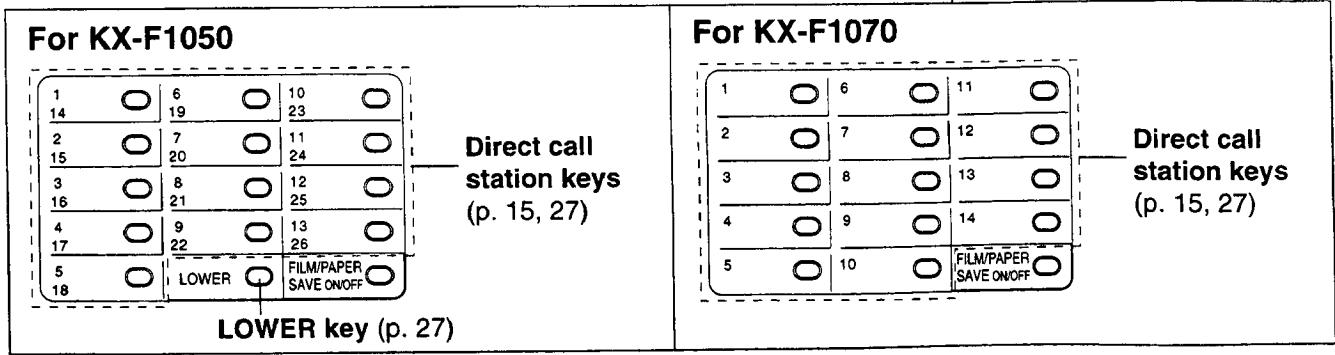
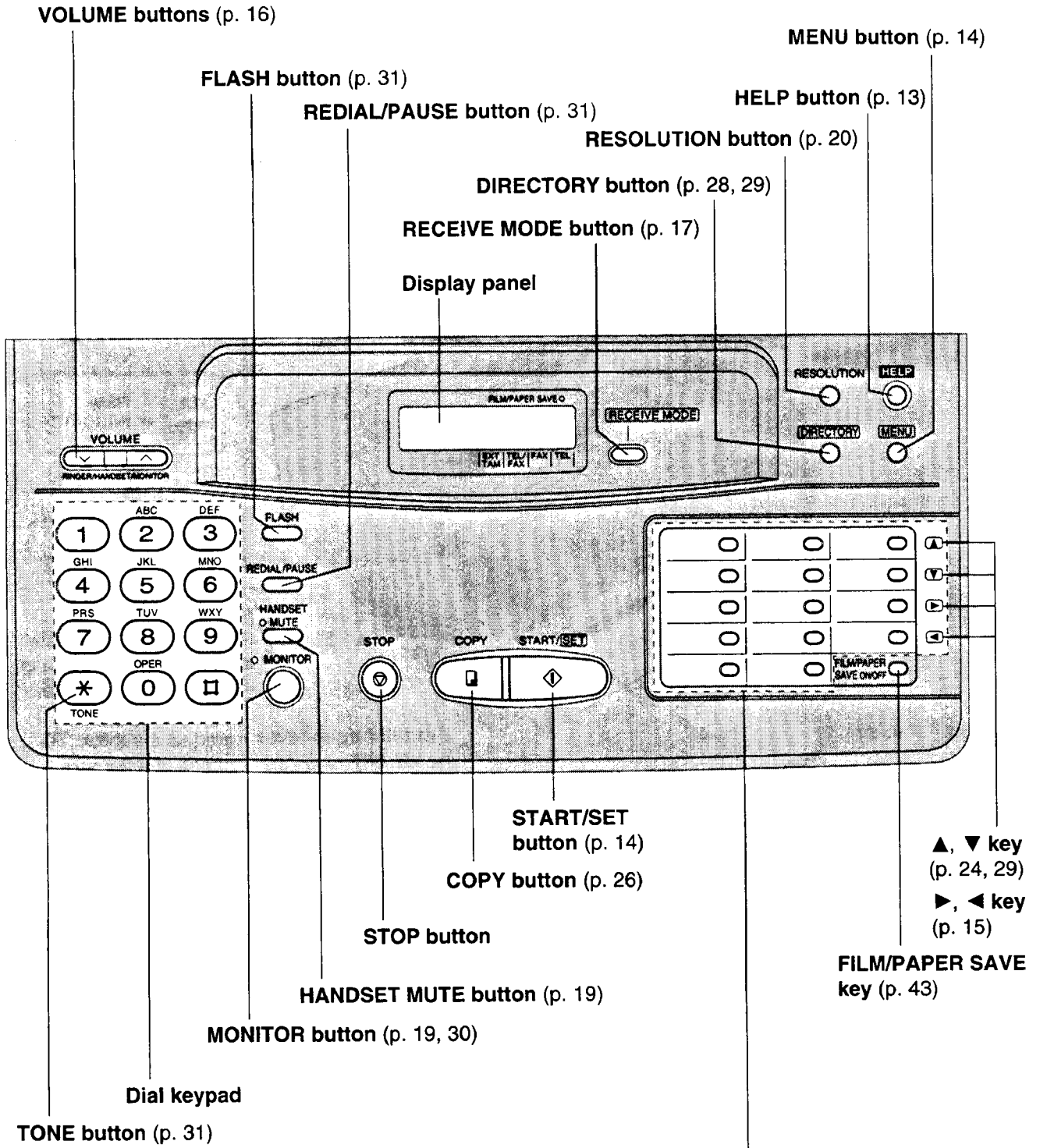



# Installing your unit

## Installing the paper cassette

You can use letter size or legal size paper. The paper cassette can hold up to 250 sheets of 75 g/m<sup>2</sup> (20 lb.) paper. Use 60 to 90 g/m<sup>2</sup> (16 to 24 lb.) paper.

- 1 Remove the paper cassette by (A) slightly lifting and (B) pulling it out of the unit.

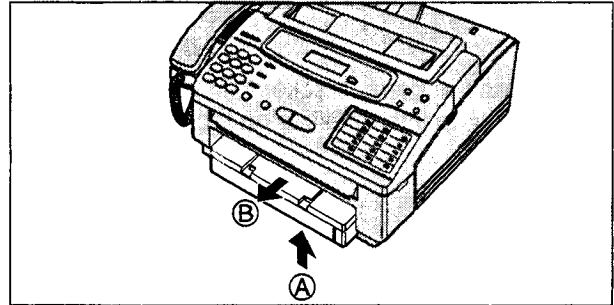

- 2 Remove the paper cassette cover.

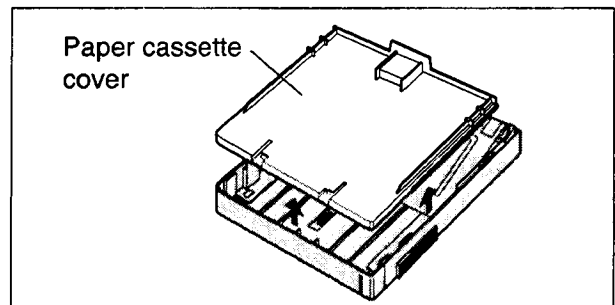

- 3 Press down on the silver plate until it is locked under the tab.

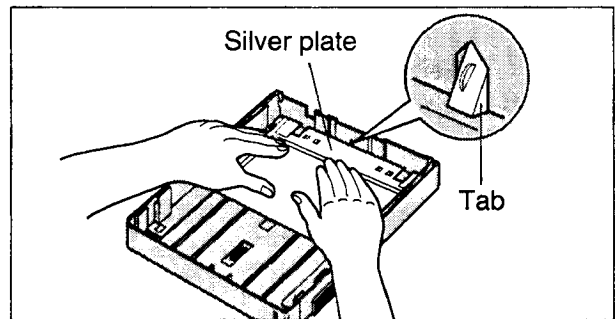

- 4 Fan the stack of paper to avoid a paper jam.

- 5 Insert the paper by aligning the paper edges with the paper level slot side on the paper cassette.

- Most paper has instructions recommending which side to print on. Insert the paper with the print side to be printed facing down.
- The height of the paper should not exceed the limit mark on the paper cassette or it may cause a paper jam.
- When using legal size paper, see page 11.

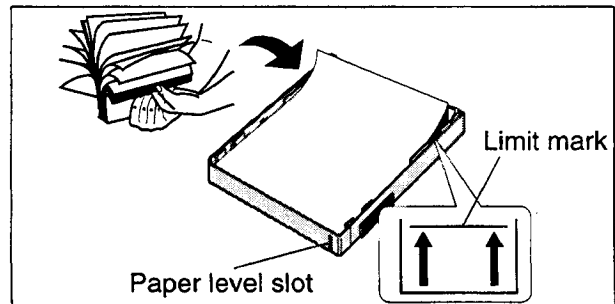

**Note:**

- We recommend to use Hammermill® jet PRINT for clearer printing.

- 6** Push down the opposite edges so they are secured under the clips.

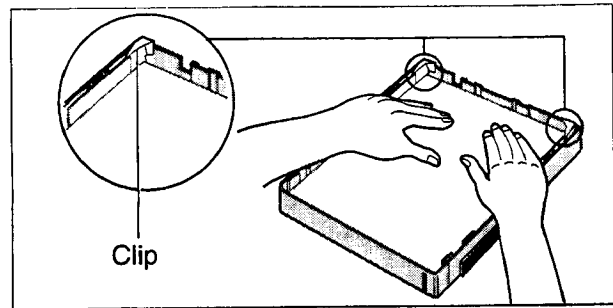
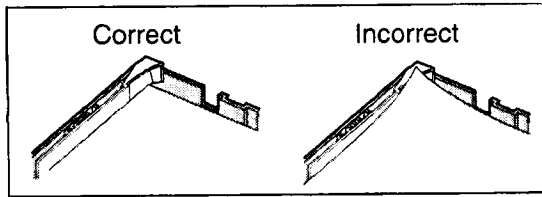

- 7** Insert the paper stacker with the bent side facing up into the slots on the paper cassette cover.

—Check that the stacker ends are inserted properly.

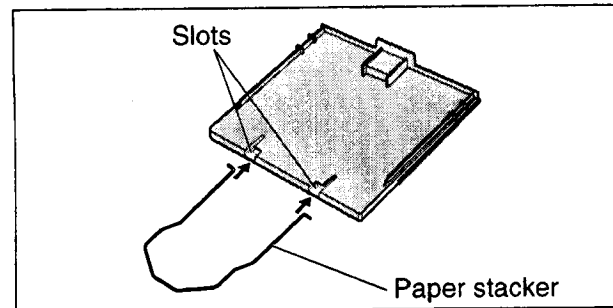

- 8** Close the paper cassette cover by inserting the both tabs on the cover into the appropriate side slots.

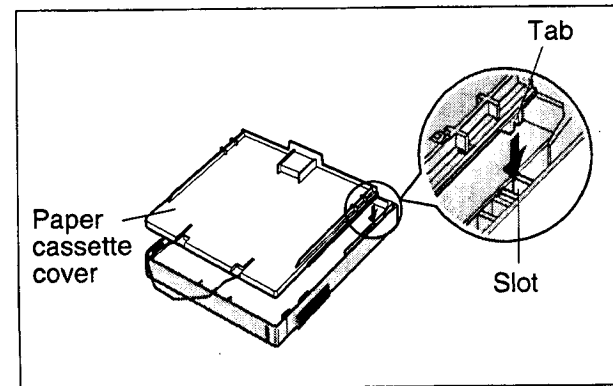

- 9** Insert the paper cassette into the unit until it clicks into place.

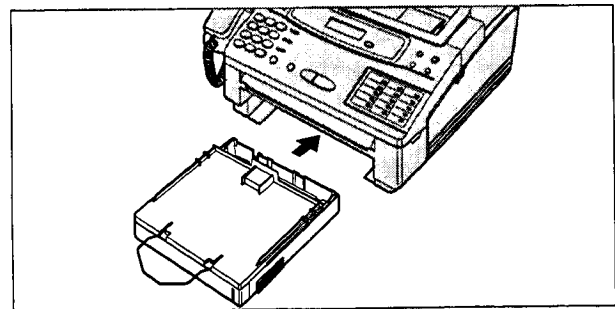

**Caution:**

•Every time the paper cassette is removed from the unit, the silver plate on the paper cassette must be pressed down and locked under the tab. If you insert the paper cassette without locking the silver plate, it may cause a paper jam.

**Note:**

- Do not use different types or thicknesses of paper in the cassette at same time. This may cause a paper jam.
- Avoid extremely smooth or shiny paper that is highly textured. Also avoid paper that is coated, damaged or wrinkled paper with a cotton and/or fiber content that is over 20 %.
- Avoid used paper for double-sided printing.
- Do not use paper printed with this unit for double-sided printing with other copiers or printers, or a paper jam may occur.

## Using legal size paper

- 1 Press the button on the paper cassette to release the tray.

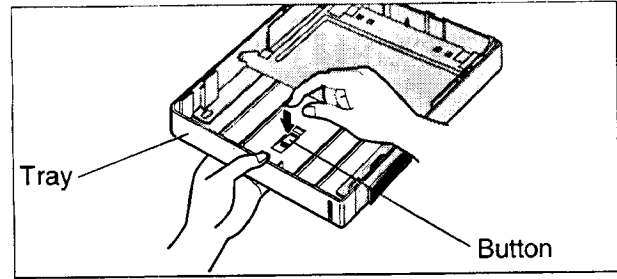

- 2 Slide the tray so that "LGL▶" on the tray aligns with "◀" on the cassette and lock into place.

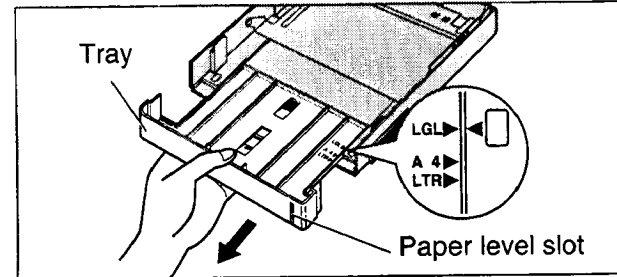

- 3 Insert the paper by aligning the paper edges with the paper level slot on the paper cassette.

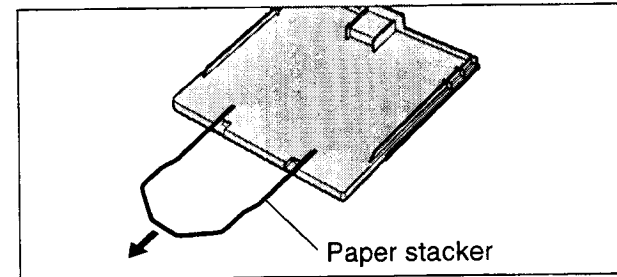

- 5 Close the paper cassette cover by inserting the both tabs on the cover into the appropriate side slots.

—The paper cassette cover does not cover the entire tray.

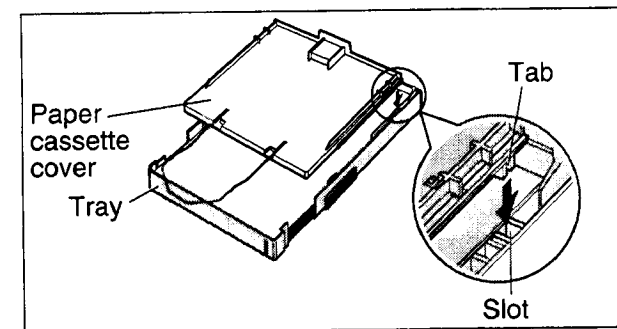

- 6 Insert the paper cassette into the unit using both hands until it clicks into place.

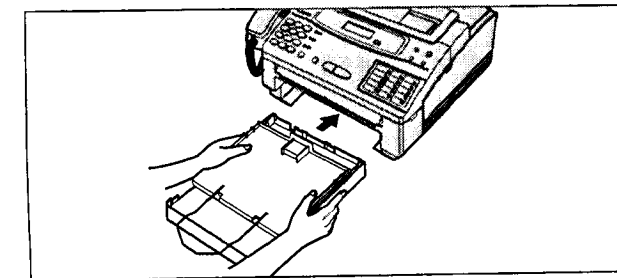

## Installing the document stacker

Insert the document stacker into the unit with the bent side facing up until it clicks into place.

### Helpful hint:

•To extend the document stacker, pull it out of the unit until it clicks into place.

To save space, slide the document stacker into the unit until it clicks into place.

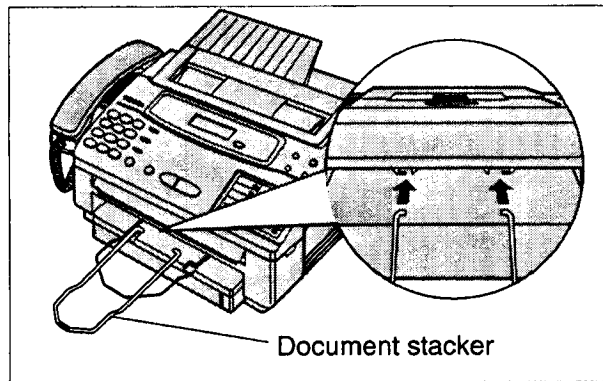

## Installing the document feeder tray

**1** Insert the three tray fins into the slots on the back of the unit (A).

**2** Press the tray down to place it on the two holders (B).

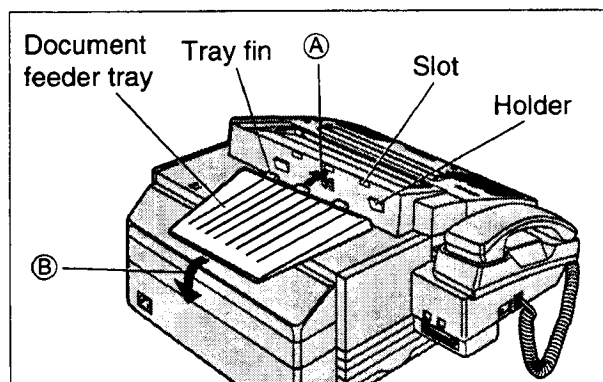

# Connections

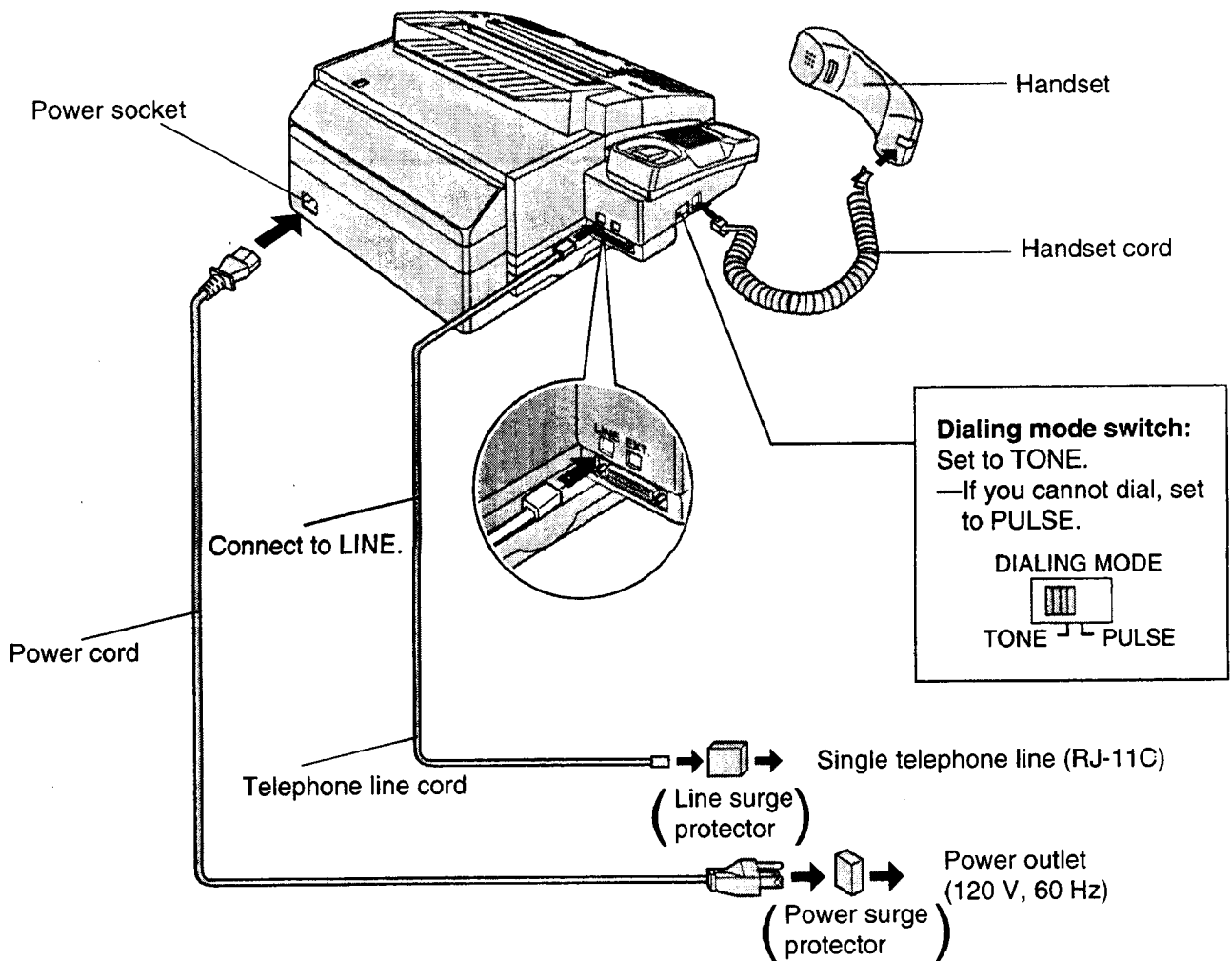

**Note:**

- For additional equipment protection, we recommend the use of a surge protector. The following types are available; TELESPIKE BLOK MODEL TSB (TRIPPE MFG. CO.), SPIKE BLOK MODEL SK6-0 (TRIPPE MFG. CO.), SUPER MAX (PANAMAX) or MP1 (ITW LINX).
- When you operate this product, the power outlet should be near the product and easily accessible.
- The unit will not function during a power failure.
- You can connect an extension phone or a telephone answering machine to the unit after peeling off the tape on the external telephone jack (EXT.). See page 46.
- To connect a RS232C cable (DB9 Female/DB25 Male), see the quick start guide.

**Helpful hint:**

- If assistance is needed, press **HELP**. The unit will print a quick reference.

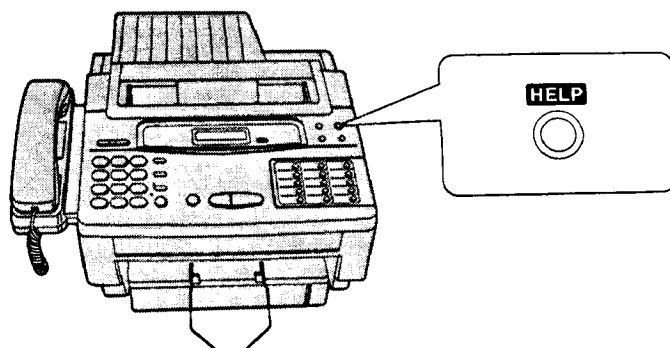

# Setting the date, time, logo and facsimile telephone number

Before using your unit, program the correct date and time, your logo and facsimile telephone number. This information will be printed on the top of each page transmitted from your unit.

## Setting the date and time

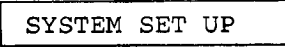
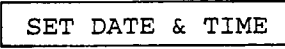
- 1 Press **MENU**.  

- 2 Press **#**, then **01**.  

- 3 Press **START/SET**.
- 4 Enter the correct month/day/year/hour/minute by selecting each 2 digits. Then press **\*** for AM or press **#** for PM.

**Example: Aug. 10 1996, 3:00PM**

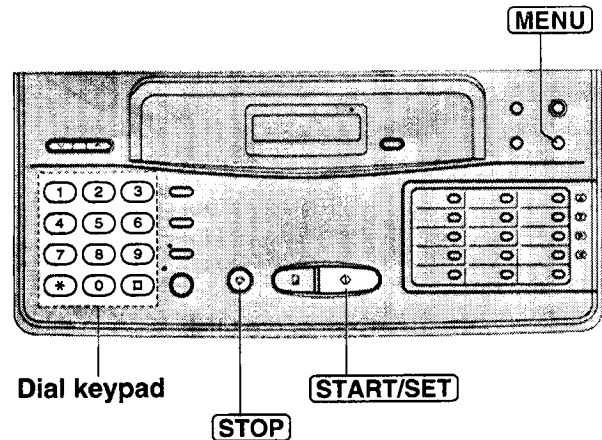
Press **08 10 96 03 00**,  
then press **#** for PM.

- 5 Press **START/SET**.
- 6 Press **MENU**.



### Note:

- When you make a mistake while programming, press **STOP** then make corrections.
- The accuracy of the clock will be approximately  $\pm 60$  seconds a month.

## Setting your logo

Usually the logo is a company, division or personal name in an abbreviated form.

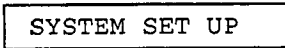
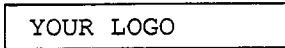
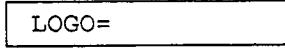
- 1 Press **MENU**.  

- 2 Press **#**, then **02**.  

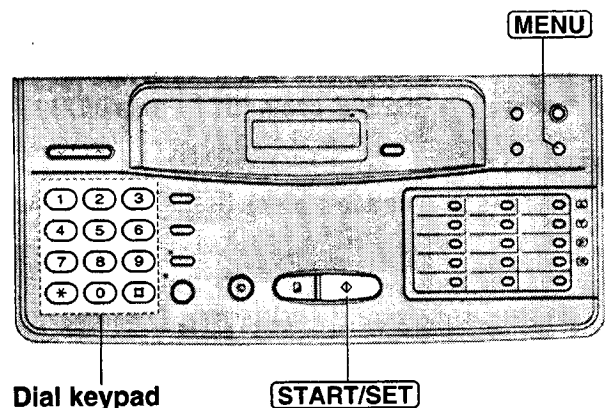
- 3 Press **START/SET**.  

- 4 Enter your logo up to 30 characters. (The preset logo will be cleared.)
  - Refer to the instructions on page 15.

- 5 Press **START/SET**.
- 6 Press **MENU**.



# How to enter characters and symbols

The dial keypad and the direct call stations can be used as character input keys and command keys. Pressing 0-9 and direct call station 1 will alternately select a character as shown below.

Keys	Number of times												
	1	2	3	4	5	6	7	8	9	10	11	12	13
①	1	[	]	{	}	+	-	/	=	,	.	_	'
②	A	B	C	a	b	c	2						
③	D	E	F	d	e	f	3						
④	G	H	I	g	h	i	4						
⑤	J	K	L	j	k	l	5						
⑥	M	N	O	m	n	o	6						
⑦	P	Q	R	S	p	q	r	s	7				
⑧	T	U	V	t	u	v	8						
⑨	W	X	Y	Z	w	x	y	z	9				
⑩	0	(	)	<	>	!	"	#	\$	%	&	¥	
1 <input type="radio"/>	:	;	?		*	@	^	'	→				
2 <input type="radio"/>	INSERT key (Used to insert one character or one space.)												
6 <input type="radio"/>	SPACE key (Used to put a blank space.)												
7 <input type="radio"/>	DELETE key (Used to delete one character.)												
12 <input type="radio"/> for KX-F1050 13 <input type="radio"/> for KX-F1070	▶ key (Used to move the cursor to the right.)												
13 <input type="radio"/> for KX-F1050 14 <input type="radio"/> for KX-F1070	◀ key (Used to move the cursor to the left.)												

Initial Preparation

For example, when entering "Mike" as your logo:

1 Press ⑥.

2 Press ④ six times.

3 Press ⑤ five times.

4 Press ③ five times.

**Note:**

• If you use the same number key continuously to enter the next character, press direct call station 12 (for KX-F1050) or 13 (for KX-F1070) to move the cursor.

**To correct a mistake while programming**

Use direct call stations 12 and 13 (for KX-F1050) or 13 and 14 (for KX-F1070) to move the cursor to the incorrect character, then make the correction.  
OR  
Press STOP to delete the character to the left of the cursor.

**To see the layout of the direct call station keys**

Remove the directory card cover with a pencil or similar object and turn the directory card over.

## Setting your facsimile telephone number

- 1 Press **MENU**.  

SYSTEM SET UP
- 2 Press **#**, then **0 3**.  

YOUR TEL NO.
- 3 Press **START/SET**.  

NO. =
- 4 Enter your facsimile telephone number up to 20 digits.
  - The **#** button inserts a space and the **\*** button a "+".
  - If you make a mistake, return to step 1 and try again.
- 5 Press **START/SET**.
- 6 Press **MENU**.

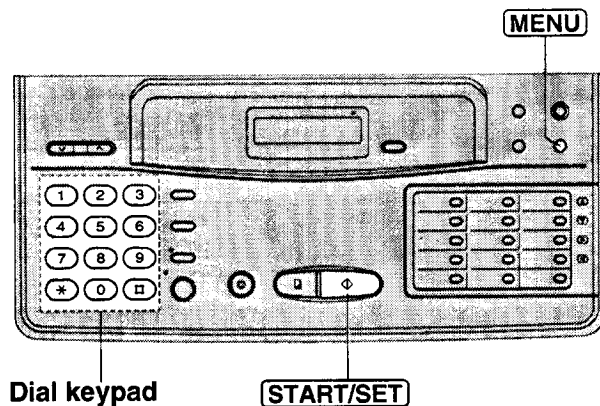

## Adjusting volumes

### ■ Ringer volume

- Press **VOLUME** (v/∧) while the unit is idle.
- 3 levels (high/low/off) are available.

#### To turn the ringer off:

1. Press **VOLUME** (v) repeatedly.
  - The following messages will be shown alternately.

RINGER OFF= OK?

 ↔ 

YES: PRESS SET

2. Press **START/SET**.

#### While the ringer volume is set to off:

The display will show the following message in idle status.

RINGER OFF

When receiving a call, the unit will not ring but will show the following message.

INCOMING CALL

### ■ Handset volume

- Press **VOLUME** (v/∧) while using the handset.
- 3 levels (high/middle/low) are available.

### ■ Monitor volume

- Press **VOLUME** (v/∧) while using the monitor.
- 8 levels (high to low) are available.

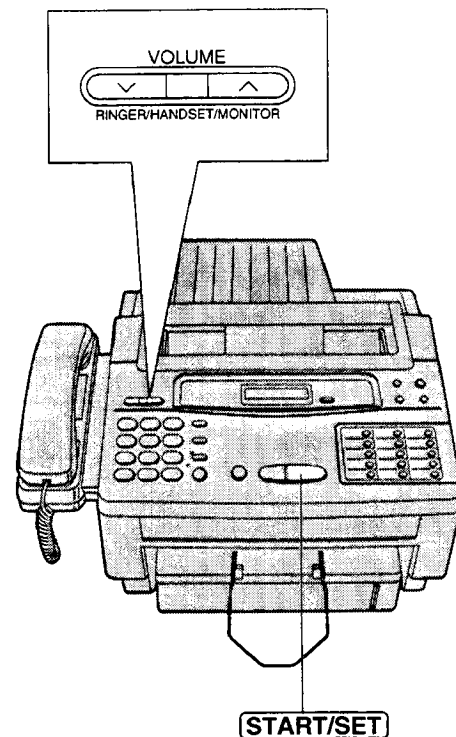



# Selecting the receive mode

## Receiving on KX-F1050/KX-F1070

This unit combines the functions of facsimile and telephone. In addition, this unit provides a TAM (Telephone Answering Machine) interface. To perform these functions, this unit has four types of receive modes; TEL/FAX, FAX, TEL and EXT. TAM.

Select the desired mode by pressing **RECEIVE MODE** repeatedly. The arrow mark in the display shows your selection.

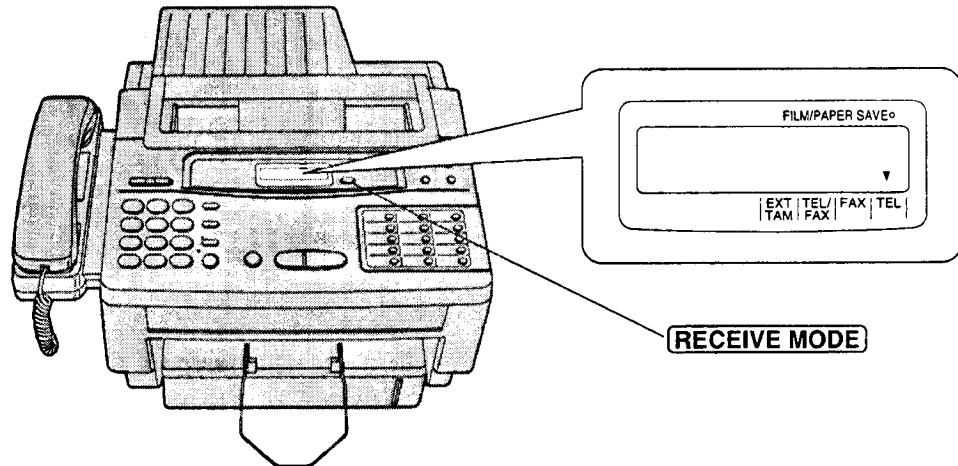

Regardless of the mode that you select, you can always place calls and send faxes. The descriptions below will help you understand how the unit can work for you.

### TEL/FAX mode:

Select this mode when you are near the unit and do not want to hear the unit ring when faxes are received but wish to answer voice calls. The unit will automatically receive fax documents without ringing. For incoming voice calls, the unit will generate a double ring. If you do not answer by the last ring, the unit will switch to the fax mode as a safe guard for missing fax documents. For further details, see page 23.

### FAX mode:

Select this mode when you will be using the unit solely as a fax machine. The unit will automatically answer all calls and generate fax tones to the callers. Callers will hear fax tones and will only be able to transmit faxes. For further details, see page 25.

### TEL mode:

Select this mode when you wish to answer all calls manually. The unit will not automatically answer fax and voice calls. To answer a fax call during a telephone conversation, you can start reception by pressing the START/SET button.

- When no one answers an incoming call by 15 rings, the unit will switch to the fax reception. The receive mode remains the TEL mode.

### EXT. TAM mode:

Select this mode when you connect a telephone answering machine (TAM) to the external telephone (EXT.) jack on your unit. If a voice call is detected, the answering machine will begin recording. If a fax call is detected, the facsimile unit will disconnect the answering machine and receive the fax documents. For further details, see page 46.

- If your external telephone does not have an answering/recording feature, do not select this mode. We recommend that you select the TEL/FAX or TEL mode.

## Receiving on your PC

This feature allows you to operate any kind of reception on the PC.

When the documents are received in the PC, you can confirm the received fax data on the screen. If necessary, you can print out the data.

Pre-selected setting is ON.

To change the setting, proceed as follows.

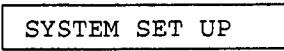
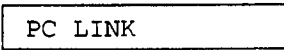
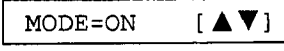
- 1 Press **MENU**.  

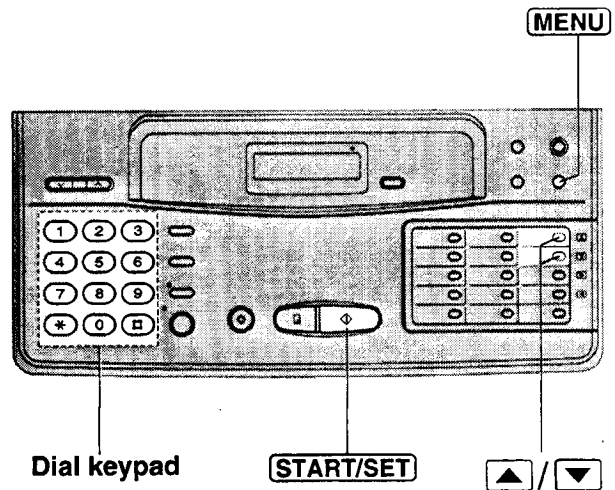
- 2 Press **#**, then **14**.  

- 3 Press **START/SET**.  

- 4 Press **▲** or **▼** to select the desired mode.
- 5 Press **START/SET**.
- 6 Press **MENU**.



### Note:

- For connecting the KX-F1050/KX-F1070 to your PC and the operation of the received fax data on your PC, see the Quick Start Guide.

# Making voice calls

- 1 Press **MONITOR** or lift the handset.
- 2 Dial a phone number.
  - If you misdial, hang up and dial again.
- 3 If using **MONITOR**, when the other party answers, lift the handset and speak into it.
- 4 When finished, hang up the handset.

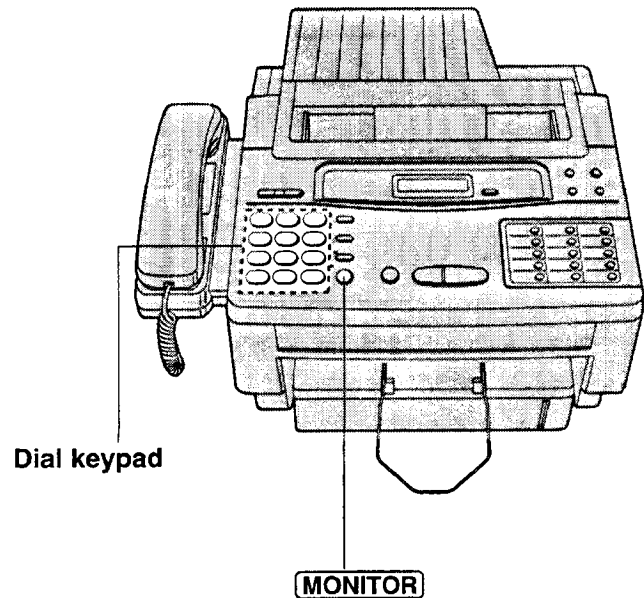

# Answering voice calls

- 1 When the unit rings, lift the handset.
- 2 When finished, hang up the handset.

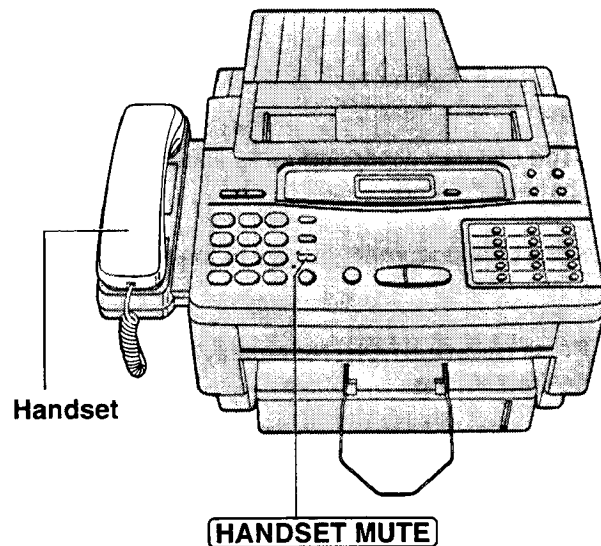

## Voice muting

Using this feature, the other party cannot hear you but you can hear them.

1. Press **HANDSET MUTE** during a telephone conversation.
  - The **HANDSET MUTE** indicator light goes on.
2. To resume the conversation, press **HANDSET MUTE** again.

# Transmitting documents

## Documents you can send

### Minimum size

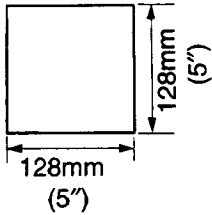

### Maximum size

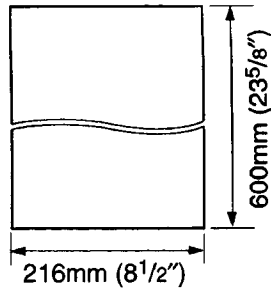

### Effective scanning area

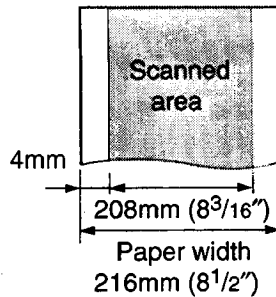

### Document weight

Single sheet:  
45 to 90 g/m<sup>2</sup> (12 to 24 lb.)  
Multiple sheets :  
60 to 75 g/m<sup>2</sup> (16 to 20 lb.)

### Note:

- Remove clips, staples or other similar fastening objects from the document.
- Check that ink, paste or correction fluid on the documents has dried.
- Do not send the following types of documents. Use copies for fax transmission.
  - Chemically treated paper such as carbon or carbonless duplicating paper
  - Electrostatically charged paper
  - Heavily curled, creased or torn paper
  - Paper with a coated surface
  - Paper with a faint image
  - Paper with printing on the opposite side that can be seen through the front (e.g. newspaper)

## Loading documents

**1** Insert the documents **FACE DOWN** until a beep tone is heard.

- The unit can accept up to 15 sheets of paper at a time.

**2** Adjust the document guides to the width of the documents.

**3** Press **RESOLUTION** repeatedly to the desired setting.

- The selected resolution will be shown on the display.

**STANDARD:** For printed or typewritten originals with normal-sized characters.

**FINE:** For originals with small printing.

**SUPER FINE:** For originals with minute printing.

**HALF TONE:** For originals containing photographs, shaded drawings, etc.

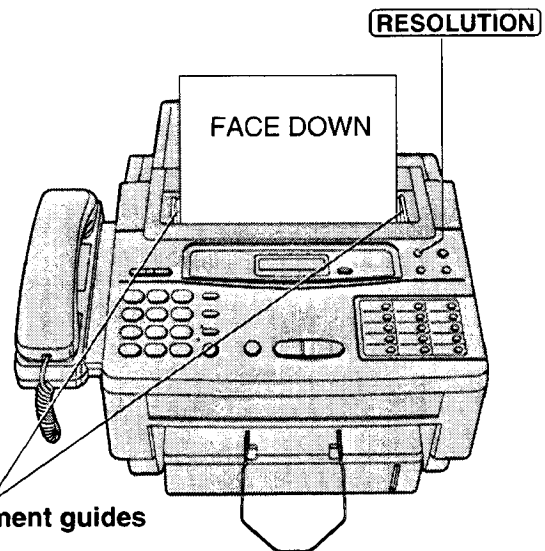

Document guides

The resolution of KX-F1050/KX-F1070 apply to on your PC as follows.

KX-F1050/KX-F1070	Your PC
STANDARD	Text
FINE	
SUPER FINE	Line art
HALF TONE	Photograph

### Note:

- Using the FINE, SUPER FINE or HALF TONE setting will increase transmission time.
- If the resolution setting is changed during page feeding, it will be effective from the next sheet.
- The SUPER FINE resolution only works with other compatible machines.

## Transmitting documents manually

- 1 Insert the documents FACE DOWN until a beep tone is heard.
- 2 Press **MONITOR** or lift the handset.
- 3 Dial a phone number.
  - If you misdial, hang up and dial again.
- 4 When a fax tone is heard, press **START/SET**.
- 5 Replace the handset if using it.

### Note:

- If the other party answers your call, ask them to start receiving a fax, then press your **START/SET** button.
- The unit will automatically end the transmission after the last sheet is transmitted.

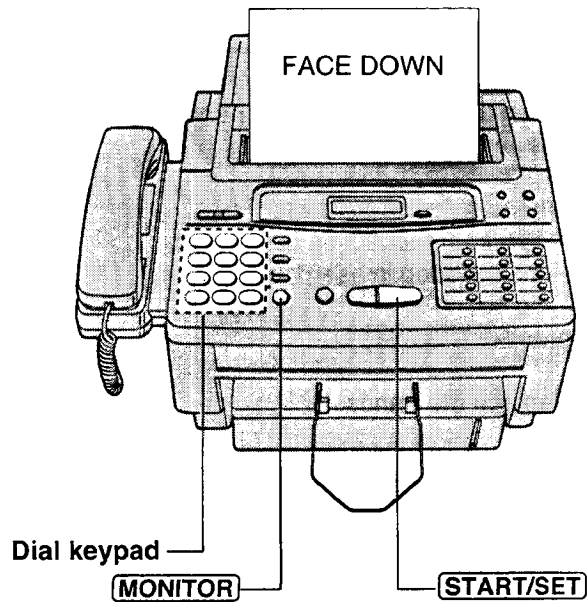

## Transmitting documents with fewer procedures

- 1 Insert the documents FACE DOWN until a beep tone is heard.
- 2 Dial a phone number.
  - If you misdial, press **STOP** and dial again.
- 3 Press **START/SET**.
  - The unit will start to dial and transmit the documents.

### Fax auto redial

If there is no answer or the line is busy, the unit will automatically redial the number up to 5 times.

This feature is available when you transmit documents with fewer procedures, such as automatic dialing (p. 27), delayed transmission (p. 33) and receive polling (p. 32). To cancel redialing, press **STOP**.

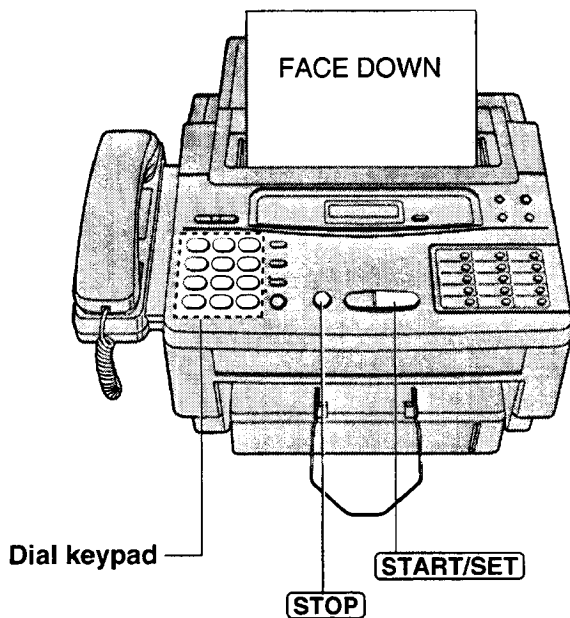

### To stop transmission

Press **STOP**.

### To send 16 or more sheets at a time

Insert the first 15 sheets of the document. Add the extra sheets (up to 15) before the last sheet is fed into the unit.

# Receiving documents

## Manual reception

- 1 When the unit rings, lift the handset to answer the call.
- 2 When:
  - document reception is required,
  - a slow beep is heard, or
  - no sound is heard,press **START/SET**.
- 3 Replace the handset.
  - The unit will start reception.

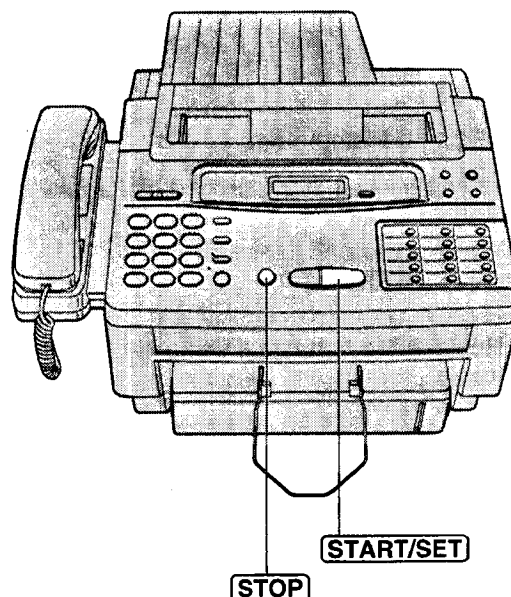

## Automatic reception

Set the unit to the TEL/FAX, FAX, or EXT. TAM mode by pressing **RECEIVE MODE**.

- When a fax call comes in, the unit will automatically activate the fax function to receive documents.

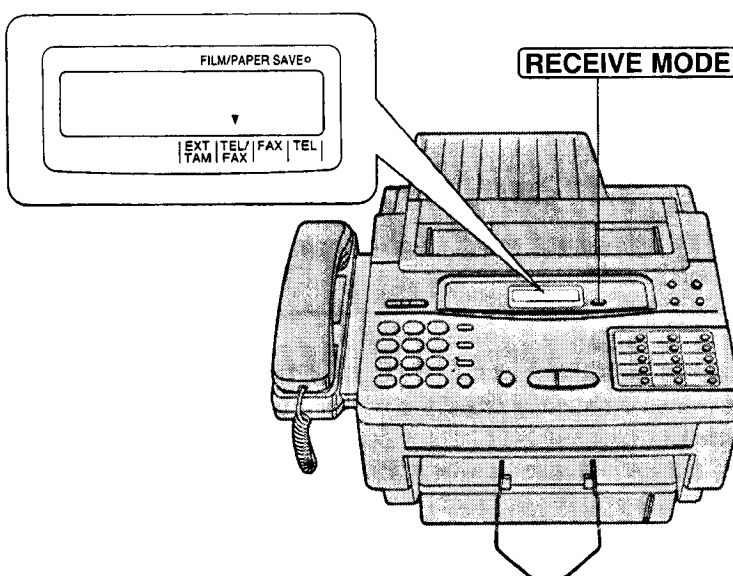

## To stop reception

Press **STOP**.

## Receiving an over-sized document

- When receiving an over-sized document, the unit will divide it into two or more pages when printing out.
- If an appropriate reduction rate (p. 42) is set, the unit can print an over-sized document on one page.

## Receiving in the TEL/FAX mode

Use this mode when you wish to receive voice calls with ring but do not want to hear the unit ring when faxes are received.

When a call is received, the unit will work as follows.

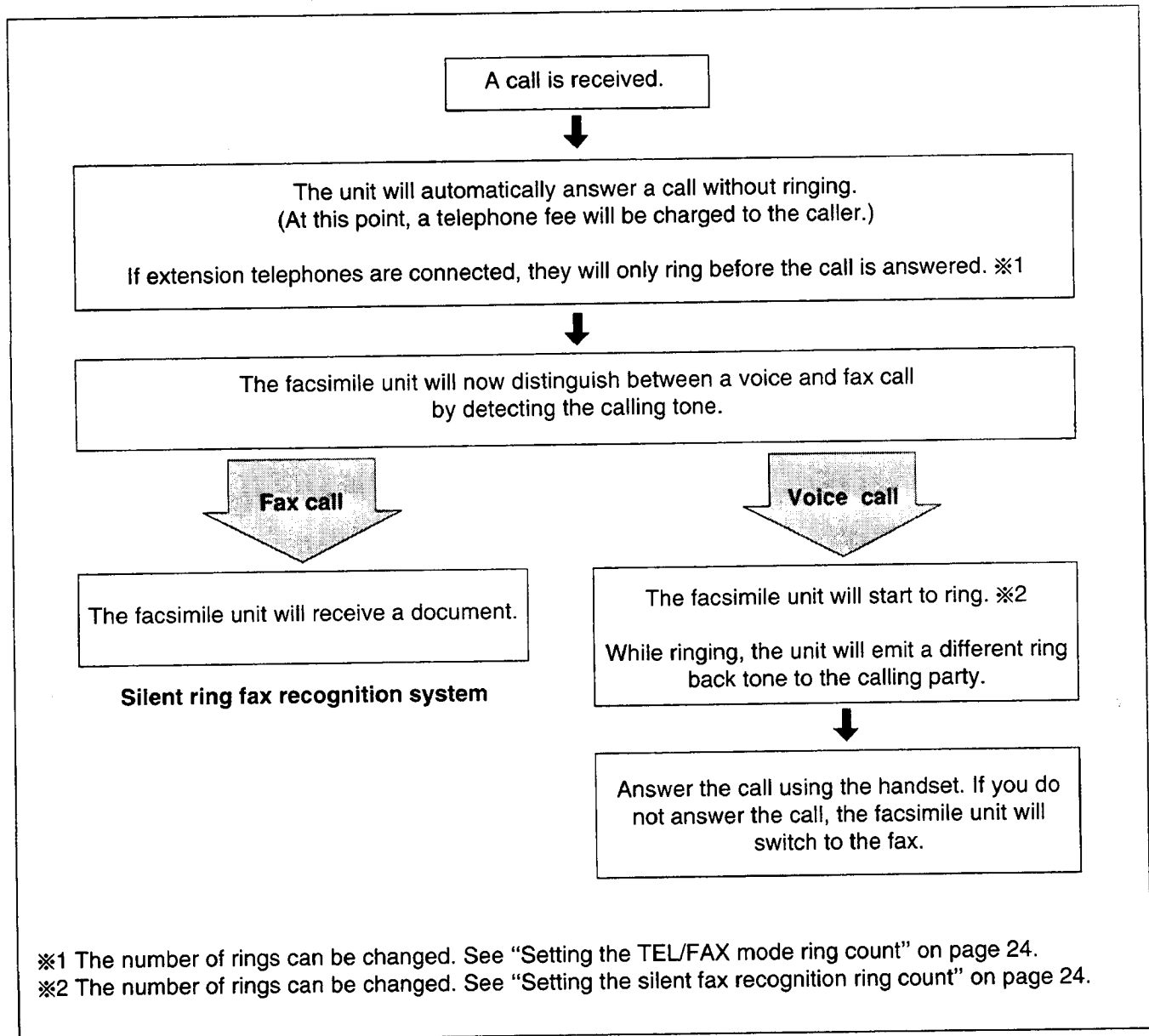



**Note:**

- Some fax messages that are transmitted manually may not send using a calling tone. These calls must be manually received.

## Setting the TEL/FAX mode ring count

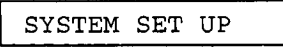
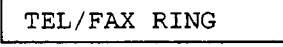
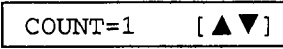

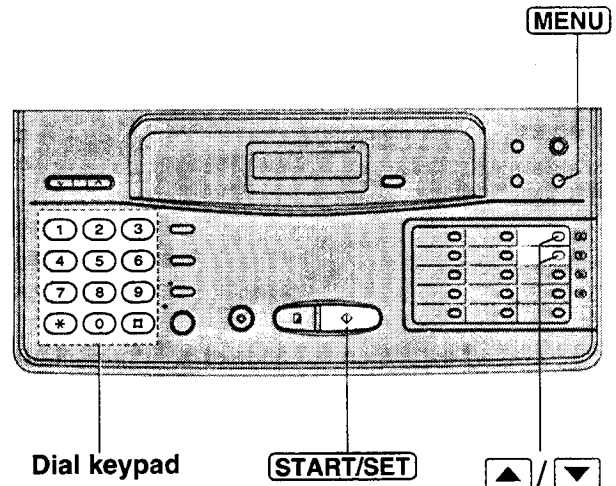

This feature determines the number of rings after which the unit answers a call in the TEL/FAX mode. You can choose from 1 to 4 rings.

- 1 Press **MENU**.  

- 2 Press **#**, then **06**.  

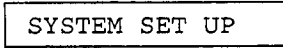
- 3 Press **START/SET**.  

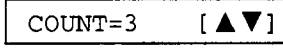
- 4 Press  or  to select the desired number.
- 5 Press **START/SET**.
- 6 Press **MENU**.

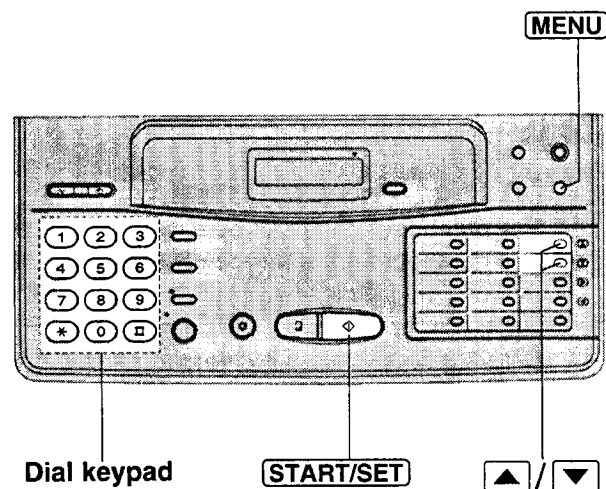

## Setting the silent fax recognition ring count

When a fax call is received in the TEL/FAX mode, the unit will automatically activate the fax function without ringing. If the unit detects a voice call, it will ring. You can choose from 3 to 6 rings.

- 1 Press **MENU**.  

- 2 Press **#**, then press **30**.  

- 3 Press **START/SET**.  

- 4 Press  or  to select the desired number.
- 5 Press **START/SET**.
- 6 Press **MENU**.





## Receiving in the FAX mode



When a call is received, the unit will automatically activate the fax function.

### Setting the FAX mode ring count

This feature determines the number of rings after which the unit answers a call in the FAX mode. You can choose from 1 to 4 rings.

#### Helpful hints:

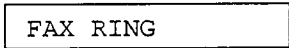
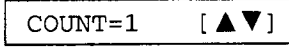
- To be able to answer a call before the unit does, increase the number of rings.
- If you find receiving faxes from machines with an automatic transmission feature difficult, decrease the number of rings.

- 1 Press **MENU**.  

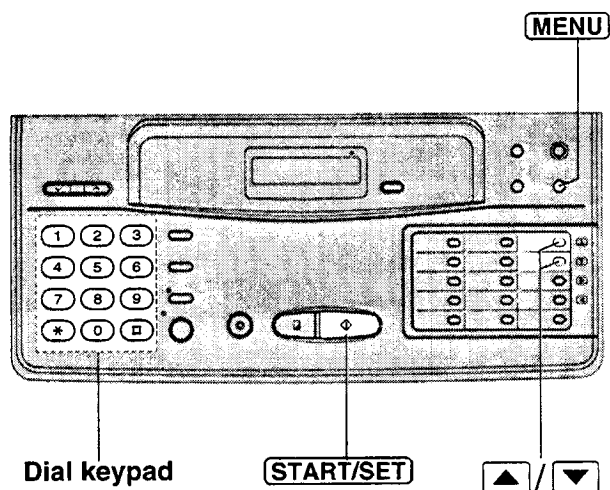
- 2 Press **#**, then press **07**.  

- 3 Press **START/SET**.  

- 4 Press  or  to select the desired number.
- 5 Press **START/SET**.
- 6 Press **MENU**.



# Making a copy

---

Any transmissible document can be copied (p. 20).

**1** Insert the documents (up to 15 sheets)  
FACE DOWN until a beep tone is heard.

**2** Press **COPY**.  
•The unit will start copying.

**Note:**

- When copying, the unit will automatically select FINE resolution if the resolution is set to STANDARD.
- You can select SUPER FINE or HALF TONE resolution (p. 20).
- You can make or receive a voice call while making a copy.

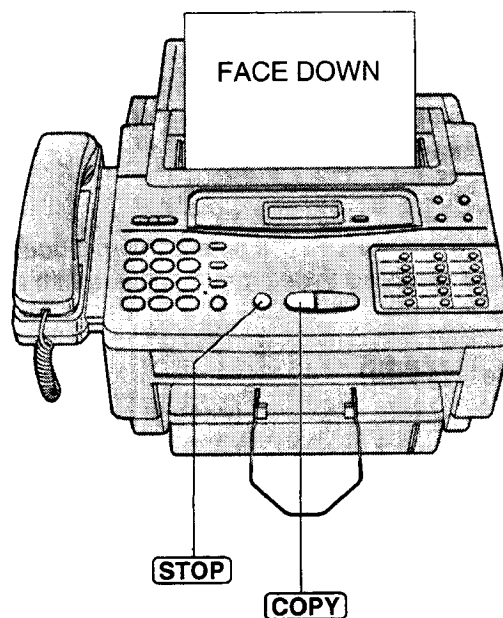

---

## To stop copying

Press **STOP**.

# Storing phone numbers for automatic dialing

The unit's memory allows you to use both one-touch dialing and speed dialing for rapid access to your most frequently dialed numbers.

**One-touch dialing:** Assigned to direct call station keys.

**KX-F1050:** Direct call station no. 1–13 (Upper stations) / 14–26 (Lower stations)

**KX-F1070:** Direct call station no. 1–14

**Speed dialing:** Assigned to 2-digit numbers.

**KX-F1050:** Dialing station no. 00–99

**KX-F1070:** Dialing station no. 00–79

To store the phone numbers in memory, proceed as follows:

- 1 Press **MENU** until the following message is displayed.

STORE TEL NO.

- 2 a: **Programming for one-touch dialing**

■ **KX-F1050**

**For upper stations 1-13**

Press one of the direct call station keys.

**For lower stations 14-26**

Press **LOWER**, then press one of the direct call station keys.

■ **KX-F1070**

Press one of the direct call station keys.

- b: **Programming for speed dialing:**

Press **#**, then press the desired 2-digit number (00-99 for **KX-F1050**) / (00-79 for **KX-F1070**).

- 3 Enter the phone number up to 30 digits in length.

•To enter a hyphen in a phone number, press **HYPHEN** (direct call station 8).

- 4 Press **START/SET**.

NAME=

- 5 Enter the station name, up to 10 characters, by following the instructions on page 15.

- 6 Press **START/SET**.

•To program other stations, repeat steps 2 to 6.

- 7 Press **STOP**.

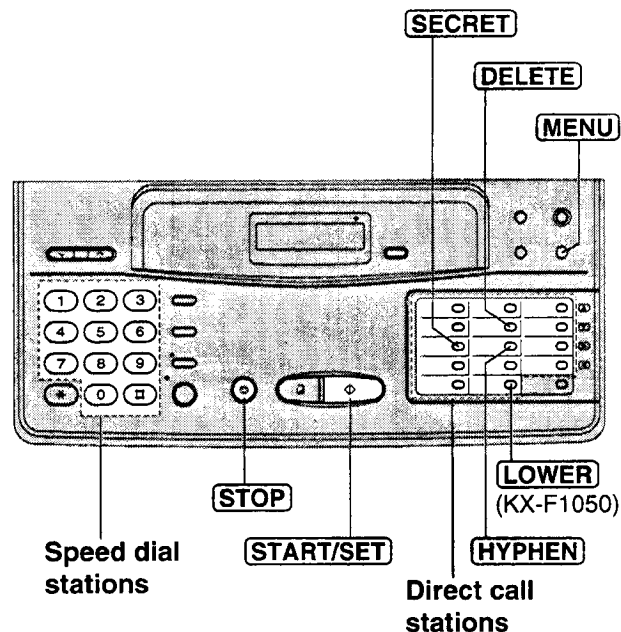

Advanced Operations

**Helpful hint:**

•To confirm stored phone numbers and station names, print a telephone number list (see page 52).

## To keep whole or part of the phone number secret

Press **SECRET** (direct call station 3) before and after the number you wish to keep secret.

- The phone number will not appear on the display and on the telephone number list.
- Pressing **SECRET** once counts as two digits.

## To erase a stored number and station name

Press **STOP** in step 3 to clear the phone number.

Press **DELETE** (direct call station 7) repeatedly in step 5 until all of the characters are erased. Then press **START/SET**.

## Making voice calls using automatic dialing

1 Press **MONITOR** or lift the handset.

2 a: Using one-touch dialing:

■ **KX-F1050**

**For upper stations 1-13**

Press the desired direct call station key.

**For lower stations 14-26**

Press **LOWER**, then press the desired direct call station key.

■ **KX-F1070**

Press the desired direct call station key.

b: Using speed dialing:

Press **DIRECTORY**, then press **#** and the desired 2-digit number (**00-99** for **KX-F1050**) / (**00-79** for **KX-F1070**).

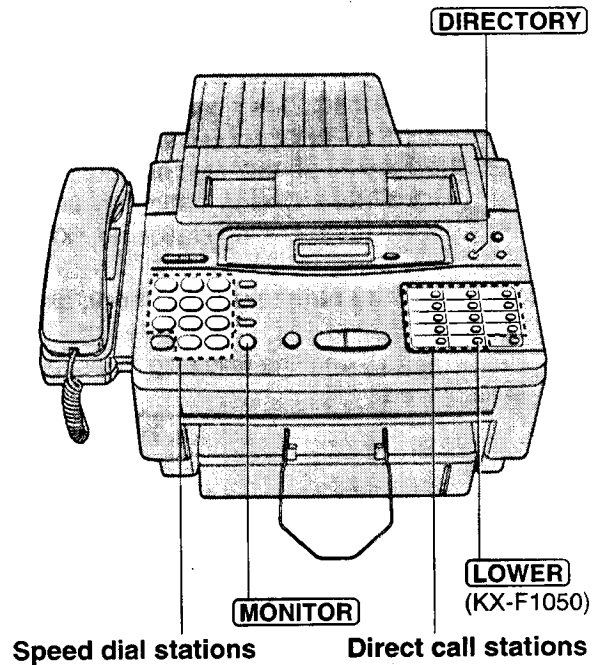

## Transmitting documents using automatic dialing

1 Insert the documents **FACE DOWN**.

2 a: Using one-touch dialing:

■ **KX-F1050**

**For upper stations 1-13**

Press the desired direct call station key.

**For lower stations 14-26**

Press **LOWER**, then press the desired direct call station key.

■ **KX-F1070**

Press the desired direct call station key.

b: Using speed dialing:

Press **DIRECTORY**, then press **#** and the desired 2-digit number (**00-99** for **KX-F1050**) / (**00-79** for **KX-F1070**).

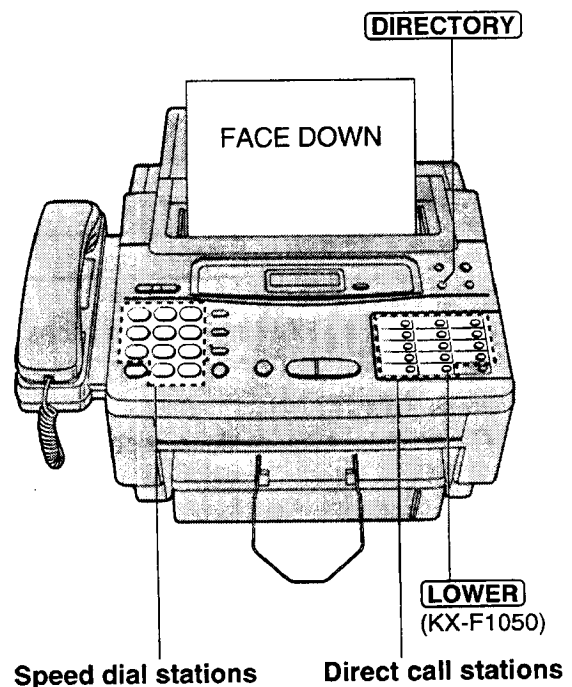

# Electronic telephone directory

The station names stored in memory are automatically registered into the electronic telephone directory in alphabetical order. You can make a fax or voice call by selecting the desired station name on the display.

If you wish to send a fax, insert the documents into the document feeder first.

1 Press **DIRECTORY**.

SELECT INDEX

2 Press the dial key in which the first initial of the station name is assigned (see the index table below).

**Example:** To search a name with the initial "N":

Press **6** repeatedly until the first station name with initial "N" is displayed. Press **▼** until the desired name is displayed.

or

Press **▲** or **▼** repeatedly until the desired name is displayed.

3 Press **START/SET**.

- The unit will start dialing.
- If a document is fed into the unit, the unit will start transmission.

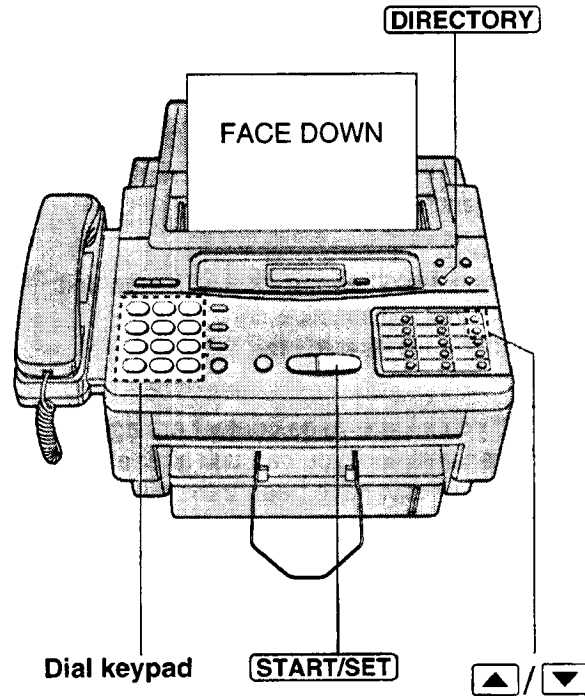

Dial key	Index	Dial key	Index
1	1	7	P, Q, R, S, 7
2	A, B, C, 2	8	T, U, V, 8
3	D, E, F, 3	9	W, X, Y, Z, 9
4	G, H, I, 4	0	0
5	J, K, L, 5	*	Other symbols
6	M, N, O, 6	#	(Used for speed dialing)

## Voice contact

(talking to the caller during or after fax reception or transmission)

You can have a conversation with the same call after the fax message is completed. This will save the extra expense and time of making another call.

**This feature works only when the other party's unit is equipped with a voice contact feature.**

### Initiating voice contact

- 1 Press **MONITOR** while transmitting or receiving documents.

VOICE STANDBY

- Your unit will call the other party with a distinctive ring.

- 2 When the other party answers, the unit will emit a distinctive ring.  
Lift the handset to start talking.

- If you initiate voice contact during transmission, you can talk after all the documents have been transmitted.
- If you initiate voice contact during reception, you can talk after the current page of the document is received.
- You can initiate voice contact by lifting the handset during transmission or reception.
- If other party does not answer, the line will be automatically disconnected.

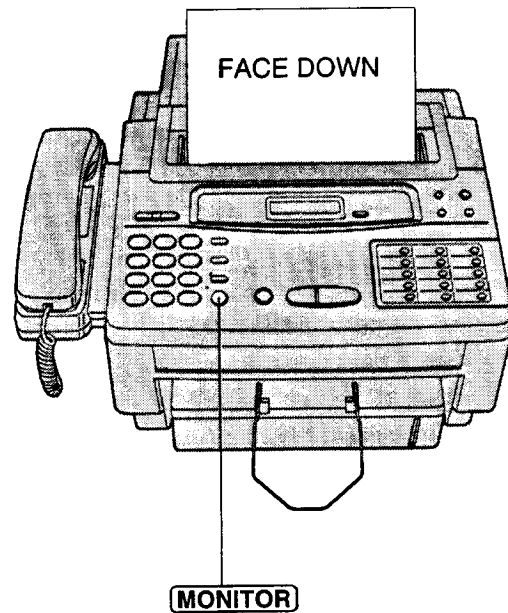

### Receiving a request for voice contact

If the other party initiates voice contact, your unit will emit a distinctive ring after transmission or reception is completed.

When the distinctive ring is heard, lift the handset, then start talking.

**Note:**

- If you do not answer within 10 seconds of hearing the distinctive ring, the line will be automatically disconnected.

# TONE, FLASH and REDIAL/PAUSE buttons

## TONE button

The TONE (\*) button is used for rotary pulse dial services, and allows you to temporarily change from pulse to tone mode during a dialing operation. When you hang up, the unit will automatically return to pulse mode.

## FLASH button

The FLASH button functions as the hookswitch on a regular phone. If you misdial or dial another phone number, press the FLASH button firmly.

The FLASH button also allows you to use special features of the host exchange (if connected) or local telephone company services such as call waiting. For further details, contact your local telephone company.

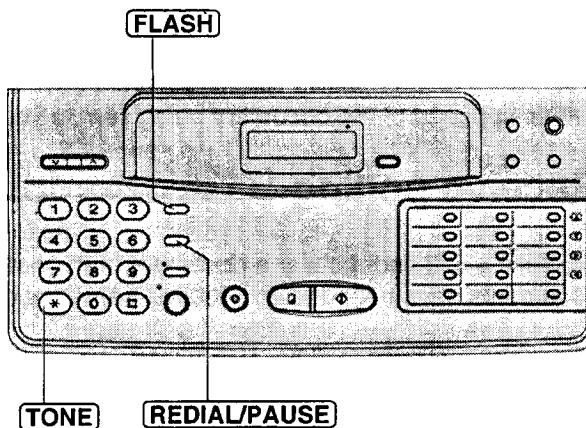

### Note:

- TONE, FLASH and PAUSE can be stored into a phone number for automatic dialing.

## Entering pauses

If the REDIAL/PAUSE button is pressed during dialing, a pause will be inserted.

**Example-1:** When your unit is connected to a host exchange, insert a pause to get an outside line.

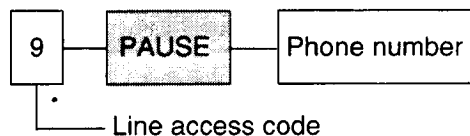

**Example-2:** If transmission errors occur when making an overseas transmission, add two pauses at the end of the phone number.

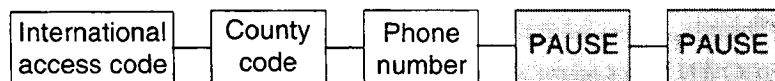

## Redialing the last number dialed

If the REDIAL/PAUSE button is pressed immediately after a dial tone is obtained, the last number dialed will be redialed.

1. Lift the handset or press **MONITOR**.
2. Press **REDIAL/PAUSE**.

- If the line is busy when using the monitor, the unit will automatically redial the number up to 14 times.

# Polling

## (retrieving fax documents)

The polling feature allows you to retrieve a document from another compatible machine where you pay for the call as opposed to the document being sent to you, thereby saving the other party call charges.

## Receive polling

To place a call and recover a document from another machine, follow the steps below. Make sure that no documents have been fed into your unit and that the other party's machine is ready for your call.

- 1 Press **MENU** until the following is displayed.

POLLING

- 2 Press **START/SET**.

NO. =

- 3 Enter the phone number by using one-touch dialing, speed dialing, full number dialing or the electronic telephone directory (see page 29).

- 4 Press **START/SET**.

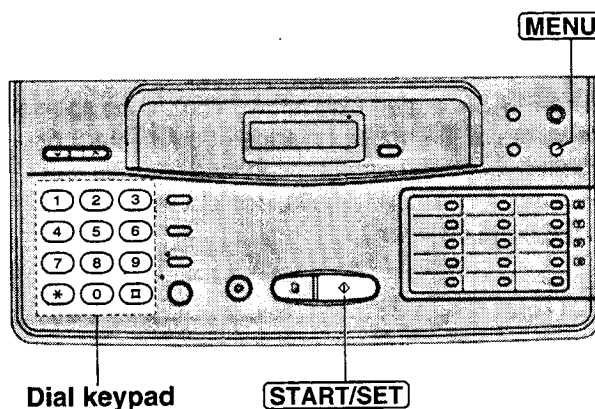

## Transmit polling

A document stored in your unit can be recovered by another party's machine. To let other machines retrieve documents loaded on your unit, proceed as follows. This feature is available in the **EXT.TAM**, **TEL/FAX** or **FAX** mode (see page 17).

- 1 Press **RECEIVE MODE** to select the EXT. TAM, TEL/FAX or FAX mode.

- 2 Insert the documents FACE DOWN.

- 3 Press **MENU** until the following is displayed.

POLLED

- 4 Press **START/SET**.

MODE=OFF [▲▼]

- 5 Press ▲ or ▼ to select "ON".

MODE=ON [▲▼]

•If this feature is not required, select "OFF".

- 6 Press **START/SET**.

POLLED ON

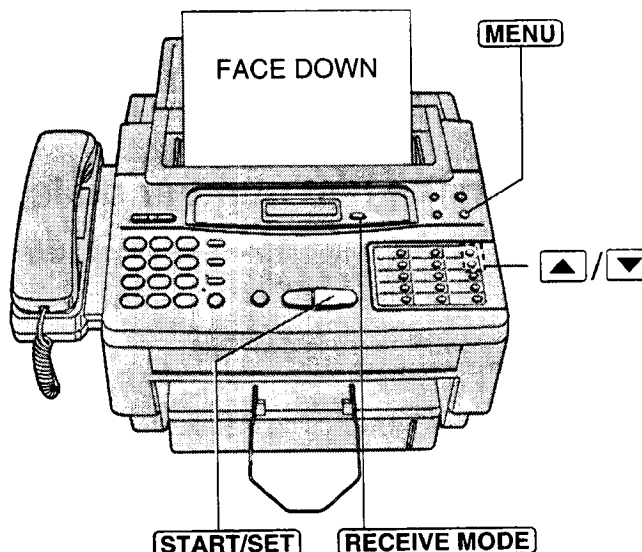

### Note:

- When delayed transmission (p. 33) is set to ON, this feature is not available.
- After the transmit polling is performed, this feature will automatically turn off.

## To cancel the transmit polling

Press **STOP**.



# Delayed transmission

(sending a fax at a later time)

Using a built-in clock, this unit can send documents automatically at a specific time. This allows you to take advantage of low-cost calling hours offered by your telephone company. The delayed transmission can be reserved to take place up to 24 hours.

- 1 Insert the documents FACE DOWN.
- 2 Press **MENU**.  

SYSTEM SET UP
- 3 Press **#**, then press **2 5**.  

DELAYED XMT
- 4 Press **START/SET**.  

MODE=OFF [▲▼]
- 5 Press **▲** or **▼** to select "ON".  

MODE=ON [▲▼]
- 6 Press **START/SET**.  

NO. =
- 7 Enter the phone number by using one-touch dialing, speed dialing, full number dialing or the electronic telephone directory.
- 8 Press **START/SET**.  

TIME=12:00AM
- 9 Enter the transmission start time.  

**Example: 11:00PM**  
 Press **1100**, then press **#** to select PM.  
 To select AM, press **\***.
- 10 Press **START/SET**.
- 11 Press **MENU**.
  - When the programmed time has come, the unit will automatically start transmission.

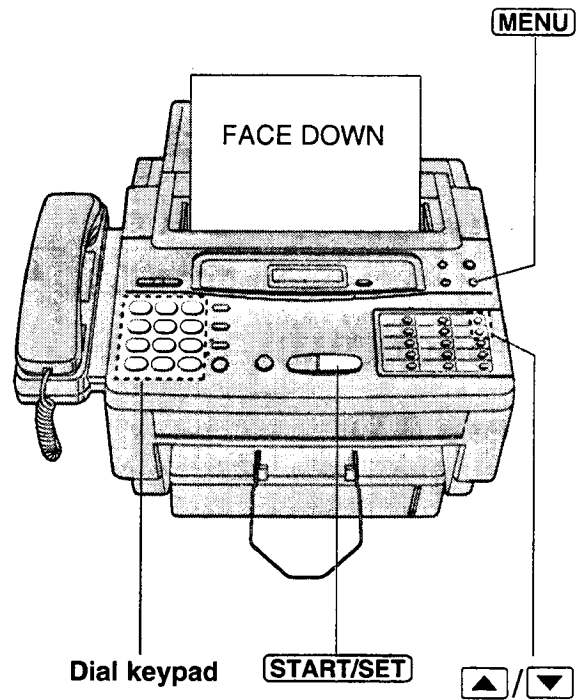

- Note:**
- You can receive, transmit and copy documents while delayed transmission is set.
  - If the programmed start time has passed during a power failure, delayed transmission will be attempted after power is restored.
  - When transmit polling (see page 32) is ON, delayed transmission is not available.

## To cancel the delayed transmission

Press **STOP**.

## Sending documents overseas

You may experience difficulty in transmitting documents overseas.

This feature makes sending documents easier as the transmission speed is slowed down. Before starting transmission, follow the steps below.

- 1 Press **MENU**.  
SYSTEM SET UP
- 2 Press **#**, then **23**.  
OVERSEAS MODE
- 3 Press **START/SET**.  
MODE=OFF [▲▼]
- 4 Press **▲** or **▼** to select "ON".  
MODE=ON [▲▼]
- 5 Press **START/SET**.
- 6 Press **MENU**.

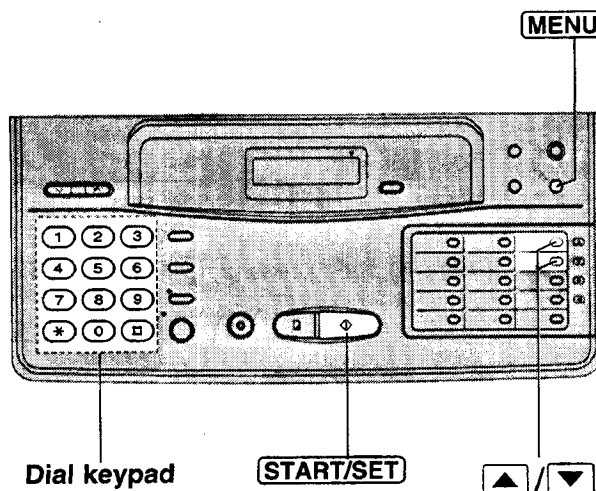

### Note:

- After transmission, this feature will be turned off automatically.

## Reserving transmission during fax reception

While the unit is receiving documents, you can reserve your fax transmission to another station. The unit will automatically transmit documents after fax reception is complete.

- 1 Insert the documents **FACE DOWN** during fax reception.
- 2 Enter the phone number by using one-touch dialing, speed dialing, full number dialing or the electronic telephone directory (p. 29).
- 3 Press **START/SET**.  
XMT RSV. ON

### To cancel the reservation

Remove the documents from the document feeder tray.

—When the fax reception is complete, the unit will show the following message.

CHECK DOCUMENT

Press **STOP** to clear the message.

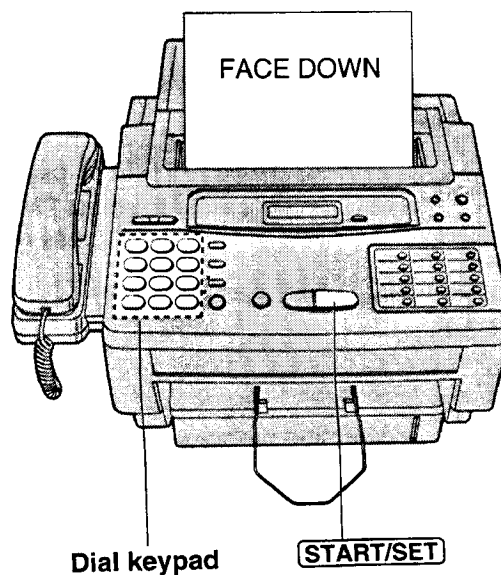

# Printing a cover page

The unit can print a cover page to attach to documents you send.

## Sample of a cover page

[FAX COVER PAGE]

TO : \_\_\_\_\_ DATE : \_\_\_\_\_  
          NAME : \_\_\_\_\_  
          FAX NO. : \_\_\_\_\_

FROM : \_\_\_\_\_  
          NAME : \_\_\_\_\_  
          FAX NO. : \_\_\_\_\_

Number of pages : \_\_\_\_\_ (including cover page)

Subject / Notes : \_\_\_\_\_

To print a cover page, proceed as follows:

1 Press **MENU** until the following is displayed.

PRINT LIST

2 Press **#**, then **7**.

FAX COVER PAGE

3 Press **START/SET** to start printing.

PRINTING

4 Press **MENU**.

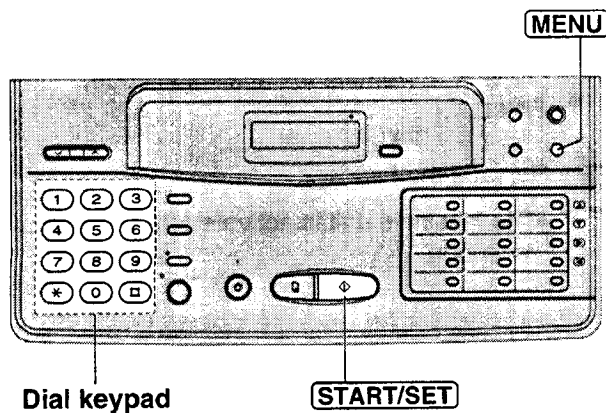

Advanced  
Operations

# Remote fax receiving

## (using an extension phone to receive a fax message)

If you have an extension phone on the same line, it is possible to receive a manual fax message. Using the extension phone, dial the remote fax activation code.

This saves you from going to the facsimile unit and pressing **START/SET**.

### Important:

- To activate this feature, use a touch tone telephone as the extension phone and enter the remote fax activation code **FIRMLY**.
- The remote fax activation code is set to “\* \*” as a pre-selected setting.

## Receiving using an extension phone

- 1 When a call is received, lift the handset of the extension phone.
- 2 When:
  - document reception is required,
  - a slow beep is heard, or
  - no sound is heard,press \* \* (remote fax activation code) **FIRMLY**.
- 3 Replace the handset.
  - The facsimile unit is activated for reception.

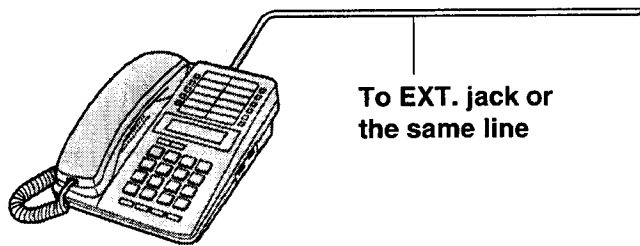

Extension phone

## Changing the remote fax activation code

This code can be from 2 to 4 digits in length using numbers 0 through 9 and the character \* . This code should not be set to “0000”.

- 1 Press **MENU**.  
SYSTEM SET UP
- 2 Press **#**, then **4****1**.  
REMOTE FAX ACT.
- 3 Press **START/SET**.  
CODE= \* \*
- 4 Enter the new code number.
- 5 Press **START/SET**.
- 6 Press **MENU**.

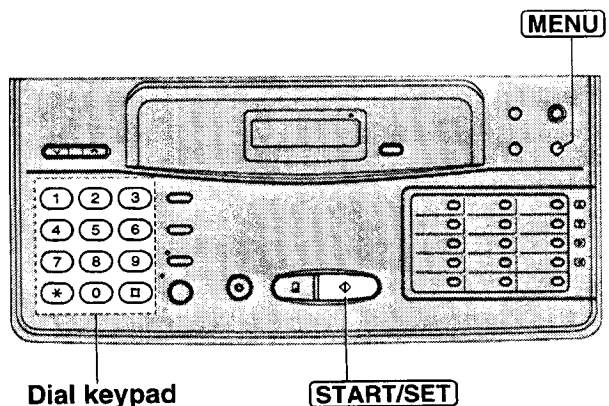

### Note:

- Some special telephone company services will require you to enter a service access code. If you subscribe to such services, whole or part of the remote fax activation code must be different from the service access code.

# Junk mail prohibitor

## (preventing the reception of unwanted fax documents)

This feature prevents reception from facsimile machines whose phone numbers are not stored in automatic dialing.

### Important:

- This feature is available when the unit is in the EXT. TAM, TEL/FAX or FAX mode.
- This feature does not work when:
  - manual reception is performed, or
  - the other party does not program their facsimile/telephone number correctly.
- If you wish to receive documents from unauthorized machines, inform your junk mail prohibitor ID to callers, and ask them to transmit the documents manually.
- The junk mail prohibitor ID must be different from the first 2 digits of the remote TAM activation ID (p. 47). e.g. If the remote TAM activation ID is "321", do not use "32" as a junk mail prohibitor ID.

## Setting the junk mail prohibitor

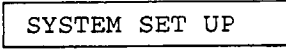
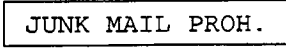
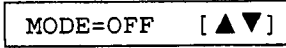
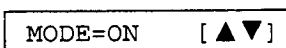
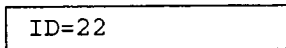
- 1 Press **MENU**.  

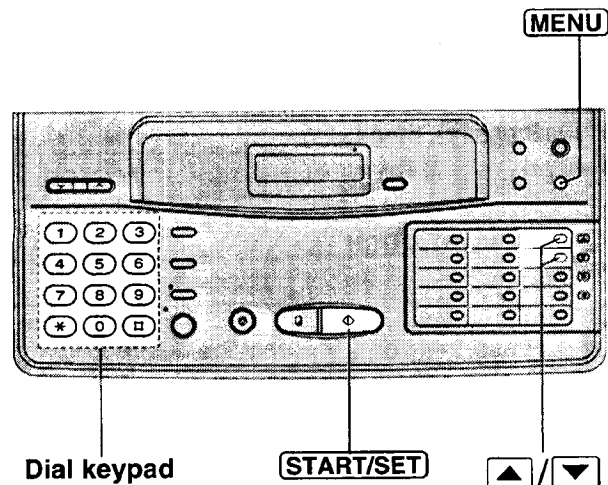
- 2 Press **#**, then **2****4**.  

- 3 Press **START/SET**.  

- 4 Press **▲** or **▼** to select "ON".  

  - If this feature is not required, select "OFF".
- 5 Press **START/SET**.  

- 6 To change the junk mail prohibitor ID, enter the desired 2-digit number.
  - 0, # and \* cannot be used.
- 7 Press **START/SET**.
- 8 Press **MENU**.



## Transmitting documents to your unit with the prohibitor ID

Even if the junk mail prohibitor feature is activated, a designated caller will be able to transmit documents. Give your junk mail prohibitor ID to all of your designated callers, and advise them of the following steps. This operation is available only in the TEL/FAX or EXT. TAM mode.

1. Call your unit from a touch tone telephone.
2. Dial the prohibitor ID while the greeting message is playing or a different ring back tone is heard.
3. Listen for a fax tone and start transmission.

# Receiving with distinctive ring service

This feature can only be used by those who subscribe to a distinctive ring pattern service from their telephone company. For more information on the availability of this service, please contact your telephone company before setting this feature to ON.

The distinctive ring service gives you up to 3 phone numbers on a single telephone line, each having a different ringing pattern.

When you use one of the phone numbers as a facsimile telephone number, program the ringing pattern assigned for fax into your unit. When the unit detects a call matching the selected distinctive ringing pattern, the unit will activate depending on the receive mode setting.

To use this feature properly, set the unit to the TEL/FAX or EXT. TAM mode (if an answering machine is used).

## Setting the distinctive ringing pattern

Program the ring pattern assigned for fax. Ringing patterns that can be programmed are;

- A:** Standard ring (One long ring)
- B:** Double ring (Two short rings)
- C:** Triple ring (Short-long-short rings)
- D:** Other triple ring (Short-short-long rings)
- OFF:** Turns off the ring pattern detection feature (pre-selected setting)

- 1 Press **MENU**.  
SYSTEM SET UP
- 2 Press **#**, then **31**.  
RING DETECTION
- 3 Press **START/SET**.  
MODE=OFF [▲▼]
- 4 Press **▲** or **▼** until the desired ringing pattern appears.
- 5 Press **START/SET**.
- 6 Press **MENU**.

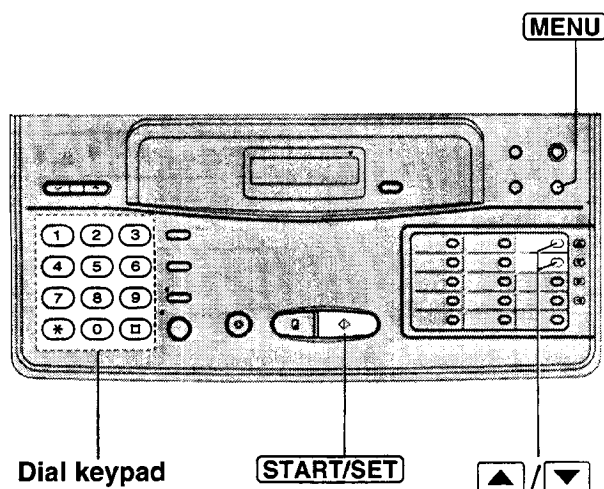

## How the unit will answer in each receive mode

- **TEL/FAX mode:** –When a distinctive ringing pattern that matches your selection is detected, the unit will automatically answer the line and activate the fax function to receive documents.  
–If other ringing patterns are received, the unit will ring until you pick up the phone.
- **EXT. TAM mode:** –When a distinctive ringing pattern that matches your selection is detected, the unit will automatically answer the line and activate the fax function to receive documents.  
–If other ringing patterns are received, the unit and the answering machine will activate depending on the call.
- **TEL mode:** In this mode, you have to answer all calls manually.
- **FAX mode:** In this mode, the unit will answer all calls and activate the fax function.

### Note:

- The unit automatically answers a distinctive ring call after the second ring. To change the number of rings, change the FAX mode ring count (p. 25) after setting the ringing pattern.

# Signaling your pager that you have received a fax document

This feature allows your unit to call your pager automatically each time your unit receives a fax message.

1 Press **MENU**.  
SYSTEM SET UP

2 Press **#**, then **70**.  
FAX PAGER

3 Press **START/SET**.  
MODE=OFF [▲▼]

4 Press **▲** or **▼** to select "ON".  
MODE=ON [▲▼]

•If this feature is not required, select "OFF".

5 Press **START/SET**.  
NO. =

6 Enter your pager phone number.  
If necessary, press **REDIAL/PAUSE** twice.  
Contact your pager company regarding the proper pause time.

If your pager has the ability to display phone numbers, enter the number that you wish to appear in the display.  
Press **#** if required by your pager company.

7 Press **START/SET**.

8 Press **MENU**.

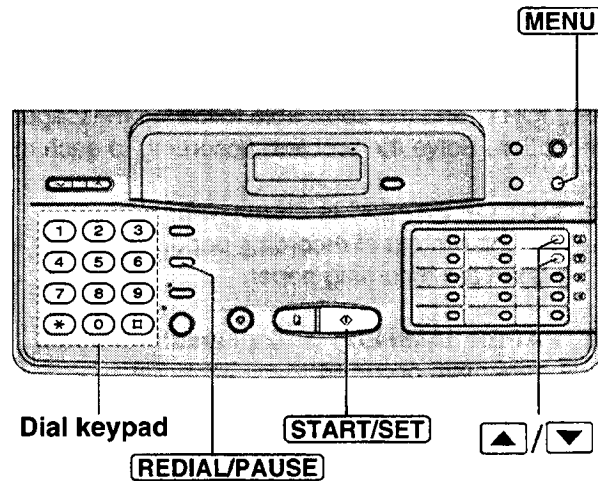

## Note:

•You may enter a total of 30 digits and/or pauses in step 6.

## Receiving documents in memory

The unit will temporarily store incoming fax documents in memory when:

- the recording paper or film runs out,
- a paper jam occurs,
- the film cartridge is not installed properly, or
- the top cover is open.

## Printing documents from memory

When documents are received in memory, the unit will alert you with beep tones and alternately show "FAX IN MEMORY" and the applicable following message(s) on the display which explain(s) the reason for memory reception. Solve the problem according to each message in order to print the stored documents.

■ **"OUT OF PAPER" is displayed:**

The unit ran out of recording paper.  
→Load the recording paper.

■ **"PAPER JAMMED" is displayed:**

A paper jam occurred.  
→Remove the jammed paper (p. 61).

■ **"CHECK CASSETTE" is displayed:**

The recording paper is jammed near the paper cassette.  
→Clear the jammed paper (p. 62).

■ **"FILM EMPTY" is displayed:**

Film is empty.  
→Replace the film or film cartridge with a new one (p. 65).

■ **"CHECK FILM" is displayed:**

The film cartridge is not inserted in the unit.  
→Insert the film cartridge.

■ **"CHECK COVER" is displayed:**

The top cover is open.  
→Close the top cover.

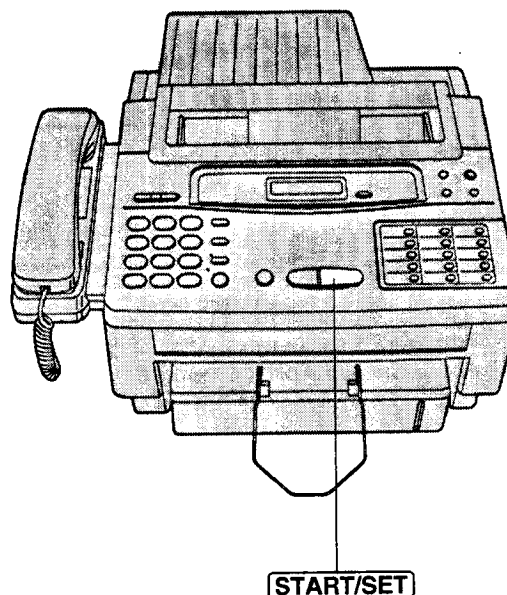

**Note:**

- For memory capacity specifications when storing documents, see page 71. If memory becomes full during reception, the unit will stop receiving documents and the display will show the following message.

MEMORY FULL

Print the stored documents to clear the memory.

- If the memory reception alert is set to OFF, the unit will not beep when documents are received in memory (p. 42).



## Setting the memory reception alert

When received documents are stored into memory, the unit will alert you with beep tones. If you hear slow beeps, clear the printing problem or supply paper to print the stored documents. The beep sound will stop.

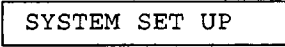
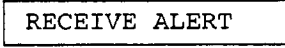
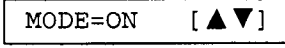
- 1 Press **MENU**.  

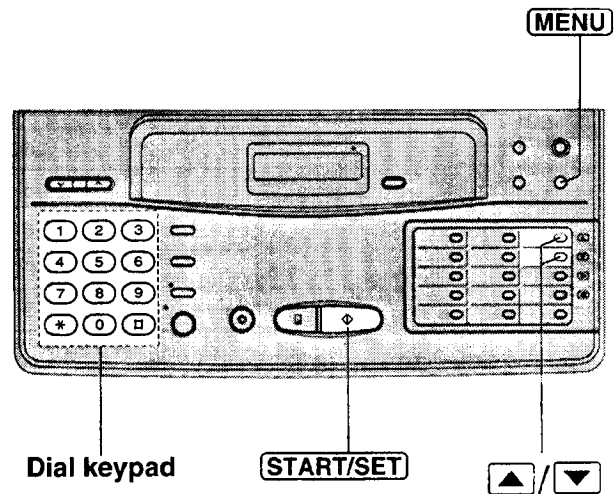
- 2 Press **#**, then **44**.  

- 3 Press **START/SET**.  

- 4 Press **▲** or **▼** to select the desired mode.
- 5 Press **START/SET**.
- 6 Press **MENU**.



# Receiving oversized documents

When the size of the documents sent by the other party is as large as or larger than the recording paper, the unit can reduce each page of the document and print it out on the recording paper at a suitable reduction rate. The reduction rate is determined by a combination of the size of the recording paper and received document.

## ■ Recommended reduction rate:

Mode	Size of recording paper	Size of received document
OFF	Legal	Letter, A4
92% (pre-selected)	Letter	Letter
	Legal	Legal
86%	Letter	A4
72%	Letter	Legal

Letter = 216 × 279 mm (8<sup>1</sup>/<sub>2</sub>" × 11")

Legal = 216 × 356 mm (8<sup>1</sup>/<sub>2</sub>" × 14")

A4 = 210 × 297 mm (8<sup>1</sup>/<sub>4</sub>" × 11<sup>11</sup>/<sub>16</sub>" ) [may not be available in the United States.]

To program a reduction rate, proceed as follows.

- 1 Press **MENU**.  

SYSTEM SET UP
- 2 Press **#**, then **36**.  

RX REDUCTION
- 3 Press **START/SET**.  

MODE=92% [▲▼]
- 4 Press **▲** or **▼** to select the desired mode.
- 5 Press **START/SET**.
- 6 Press **MENU**.

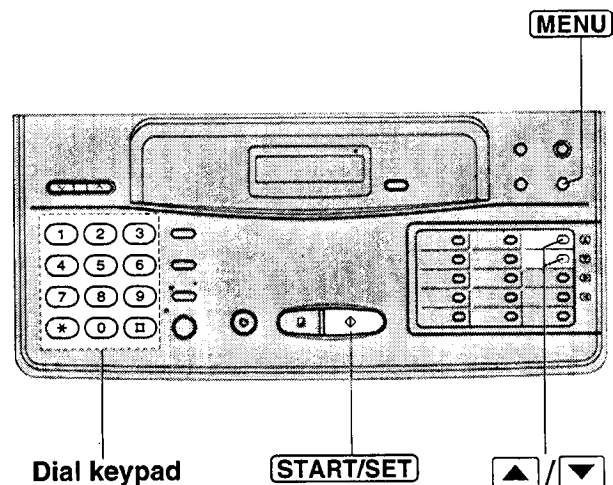

## Note:

- This feature is not available when the film/paper save reception feature is set to ON (p. 43).
- Documents received by facsimile frequently have a heading on the top of each page which contains the sender's name/phone number. This increases the length of each page. Therefore, it is recommended to use the reduction mode.
- If the appropriate reduction rate is not programmed, the over-sized document will be divided.

# Film/paper save reception

Use this feature if you wish to save film and recording paper when receiving two or more faxed pages. When this feature is set, the unit will reduce the received document to half its length and print two pages of the document on one page. A boundary will be printed out between the document.

## Sample of paper save print:

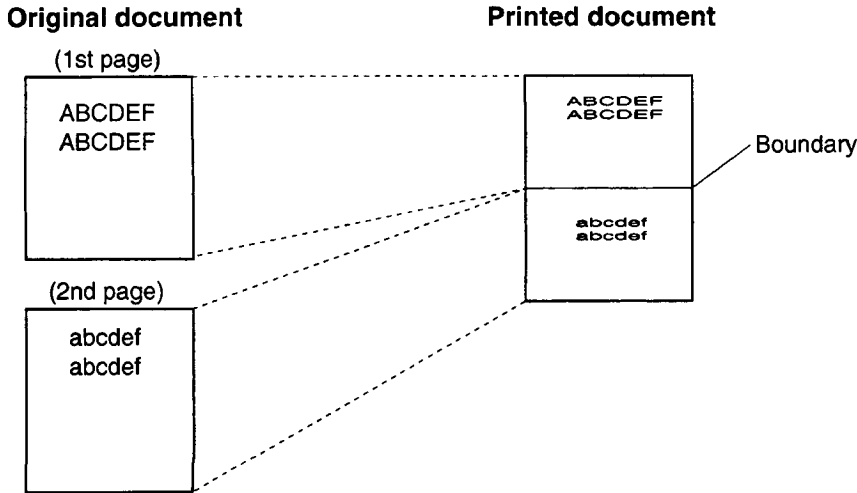

## Setting the film/paper save function

- 1 Press **FILM/PAPER SAVE**.
  - The following messages will be alternately displayed.

PAPER SAVE=ON?  
YES: PRESS SET

- 2 Press **START/SET**.
  - The arrow mark will be displayed.

FILM/PAPER SAVE  
▲  
|EXT|TEL|FAX|TEL|  
|TAM|FAX|

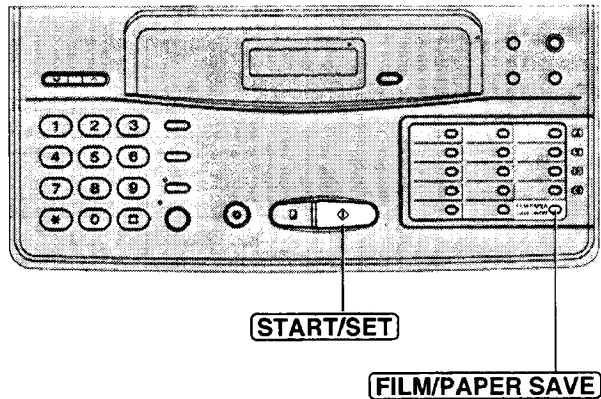

### Note:

- This feature will not work when the other party sends a document in fine resolution or another nonstandard resolution.
- When a reduced document is longer than the recording paper, it will be printed on two pages. The continuation will be printed on next page and there may be wasted space. In this case, paper and film will not be saved.
- When original documents are longer than legal size (356mm in length), the unit will not print the next page of the document on the same page.
- Paper and film will not be saved for a one page document and the last page of odd numbered documents.

## To deactivate this feature

- 1 Press **FILM/PAPER SAVE**.
  - The following messages will be alternately displayed.

PAPER SAVE=OFF?  
YES: PRESS SET

- 2 Press **START/SET**.

# Making an enlarged copy

Use this feature to enlarge a document to twice the length of the paper that is being used in the paper cassette. This feature is used to reverse the film/paper save function (see page 43).

## Sample of enlarged copy:

When you wish to enlarge the top half of the document:

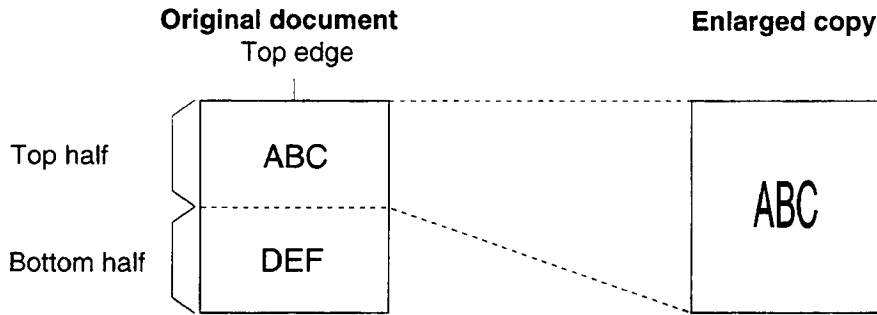

Insert the document into the unit from the top edge side FACE DOWN.

## To make an enlarged copy:

1 Insert the documents FACE DOWN.

2 Press **MENU**.

SYSTEM SET UP

3 Press **#**, then **3****4**.

EXTENSION COPY

4 Press **COPY**.

COPYING

•The unit will start making a copy.

5 After making a copy, press **MENU**.

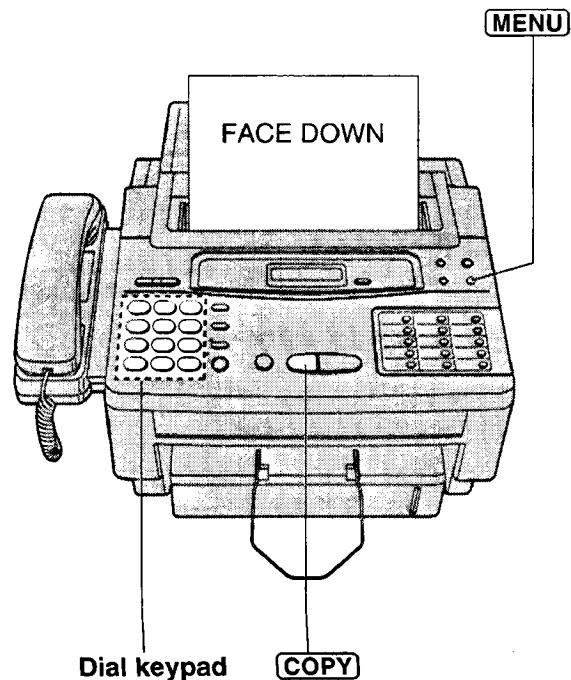

## Note:

- FINE, SUPER FINE or HALF TONE resolution cannot be used.
- To make an enlarged copy of the whole page whose length is as long as, or shorter than your installed paper:  
First insert the top half of the original document into the feeder tray and copy. Then turn the original around and insert the bottom half of the document into the feeder tray and copy.

# Making a reduced copy

When you copy documents that are longer than the recording paper, the unit can reduce the original document and print it on one page by programming a suitable reduction rate. The reduction rate is determined by a combination of the size of recording paper and original document.

## ■ Recommended reduction rate:

Mode	Size of recording paper	Size of original document
<b>OFF</b> (pre-selected)	Letter	Letter
	Legal	Letter, A4, Legal
<b>92%</b>	Letter	A4
<b>72%</b>	Letter	Legal

Letter = 216 × 279 mm (8<sup>1</sup>/<sub>2</sub>" × 11")

Legal = 216 × 356 mm (8<sup>1</sup>/<sub>2</sub>" × 14")

A4 = 210 × 297 mm (8<sup>1</sup>/<sub>4</sub>" × 11<sup>11</sup>/<sub>16</sub>" ) [may not be available in the United States.]

To program a reduction rate, proceed as follows.

- 1 Press **MENU**.  

SYSTEM SET UP
- 2 Press **#**, then **3** **5**.  

COPY REDUCTION
- 3 Press **START/SET**.  

MODE=OFF [▲▼]
- 4 Press **▲** or **▼** to select the desired mode.
- 5 Press **START/SET**.
- 6 Press **MENU**.

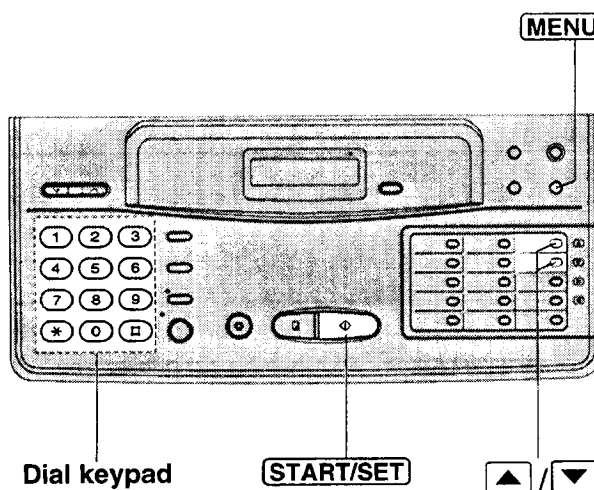

Advanced Operations

### Note:

- If the appropriate reduction rate is not programmed the document may be divided and the top of the second sheet will be deleted.

# Using an external telephone answering machine

This unit can be connected to an external telephone answering machine (TAM). When the EXT. TAM mode is selected, incoming voice messages will be recorded on the telephone answering machine and fax messages will be received by the facsimile unit.

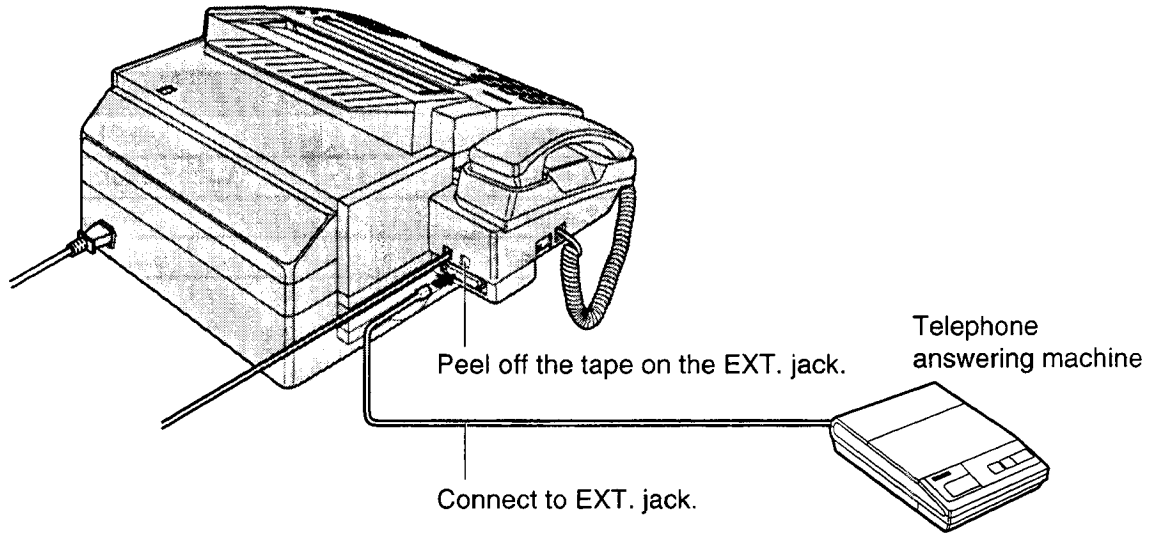

When the EXT. TAM mode is selected, incoming voice messages will be recorded on the telephone answering machine and fax messages will be received by the facsimile unit.

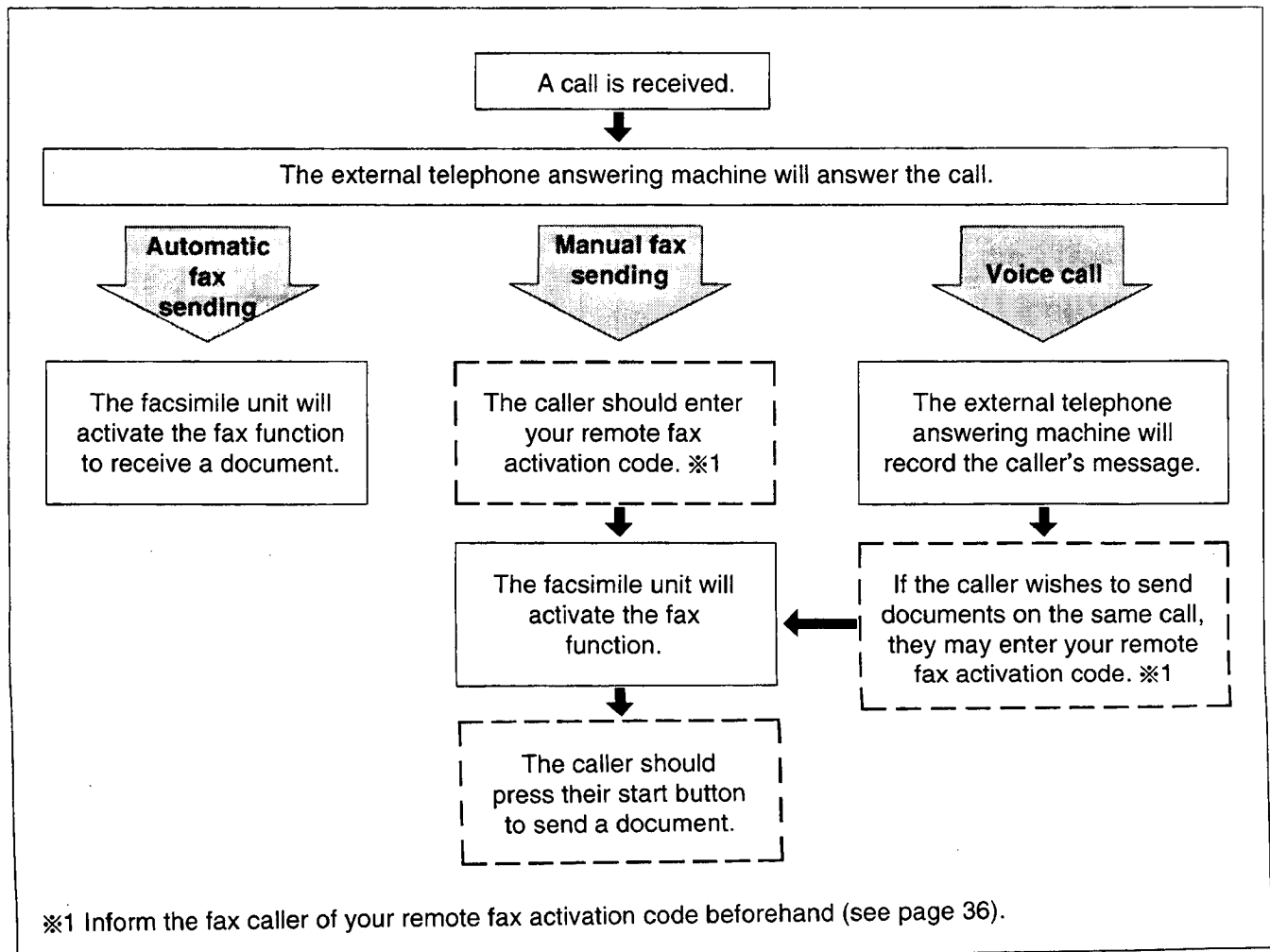

## Setting up the answering machine

1. Connect the telephone answering machine to the EXT. jack.
2. Set the number of rings on the telephone answering machine to less than 4.
3. Record a greeting message referring to the example below.

*"This is (your name, business and/or telephone number). We are unable to answer the phone right now. Please leave a message after the long beep. To send a fax, enter my remote fax activation code and start transmission. Thank you."*

### Notice for recording a greeting message:

- Do not pause for more than 4 seconds in the message.
- Your message can be 8 to 16 seconds long. We recommend you to keep it around 10 seconds in length.
- Inform the fax caller of your remote fax activation code beforehand (p. 36).

## Receiving voice and fax messages

### Setting the remote TAM activation ID

If your answering machine is equipped with a remote operation feature, set the same access code on the facsimile unit as programmed on the answering machine. This code can be from 1 to 5 digits in length.

#### Important:

- This code should be different from the remote fax activation code (see page 36) and the junk mail prohibitor ID (p. 37).

- 1 Press **MENU**.

SYSTEM SET UP

- 2 Press **#**, then press **11**.

REMOTE TAM ACT.

- 3 Press **START/SET**.

MODE=OFF [▲▼]

- 4 Press **▲** or **▼** to select "ON".

MODE=ON [▲▼]

- 5 Press **START/SET**.

ID=11

- The display will show the pre-selected ID.

- 6 Enter the new ID number using the dial keypad.

- 7 Press **START/SET**.

- 8 Press **MENU**.

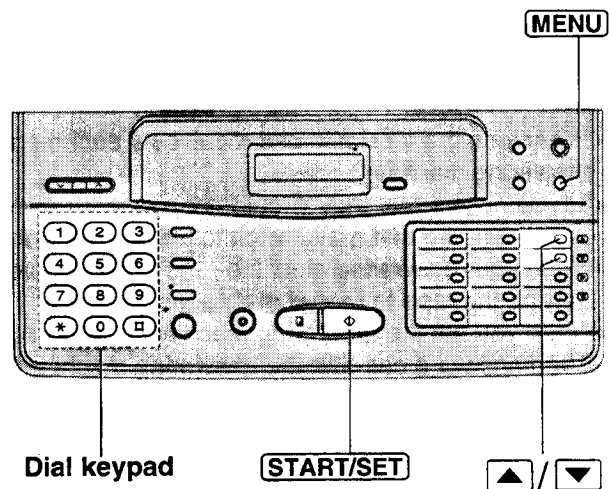





## Setting the silent detection

This feature allows the facsimile unit to activate the fax function automatically when a silent pause longer than 4 seconds is detected in the EXT. TAM mode.

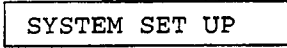
### Helpful hints:

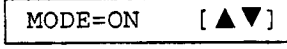
- If you wish to receive documents from stations that do not send a calling tone after dialing, activate this feature.
- If you use a single cassette tape to give a greeting message and to record incoming messages, deactivate this feature.

- 1 Press **MENU**.  

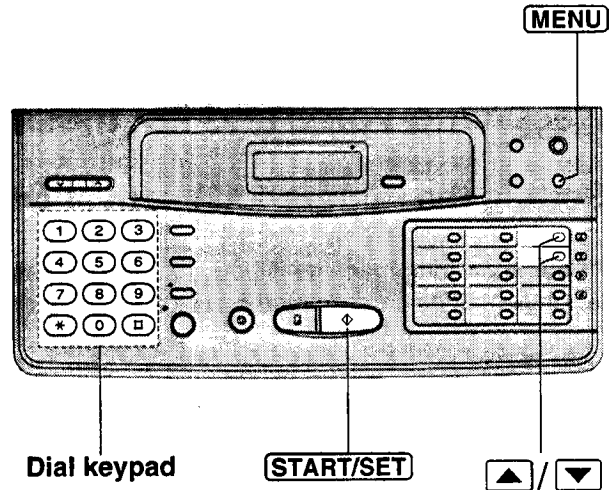
- 2 Press **#**, then press **38**.  

- 3 Press **START/SET**.  

- 4 Press  or  to select the desired mode.
- 5 Press **START/SET**.
- 6 Press **MENU**.



## Notice when using with an answering machine

- Every time the facsimile unit receives a document, a silent pause or a fax tone may be recorded on the answering machine.
- Advise callers that they should not pause for over 4 seconds while recording their voice messages. Otherwise, the unit may switch to the fax function.
- When your answering machine runs out of recording tape, your unit may not be able to receive a document. Rewind the tape to record messages.
- When you set the answering machine to give only a greeting message, fax reception may not be available.
- If you answer a call with the answering machine and pause for over 4 seconds, the unit may switch to the fax mode and you may not be able to talk with the other party. To continue the conversation, press **STOP** on the facsimile unit.
- When the answering machine does not answer a call after 5 rings, the fax function will be activated.
- Set the receive mode of the facsimile unit to the TEL mode under the following conditions:
  - when you wish to set the number of rings on the answering machine to more than 5, or
  - when you wish to use auto transfer functions (transfer, pager alert, etc.) on the answering machine.Note that automatic fax sending cannot be received automatically in the TEL mode.



## Changing the logo print position

The logo, telephone number, date, time and page number will be printed on the transmitted document from your unit in the following manner.

**OUT:** Outside of the transmitted document's paper size (pre-selected setting).

**IN:** Inside of the transmitted document's paper size.

To change the setting, proceed as follows.

- 1 Press **MENU**.  
SYSTEM SET UP
- 2 Press **#**, then **21**.  
LOGO POSITION
- 3 Press **START/SET**.  
MODE=OUT [▲▼]
- 4 Press ▲ or ▼ to select the desired setting.
- 5 Press **START/SET**.
- 6 Press **MENU**.

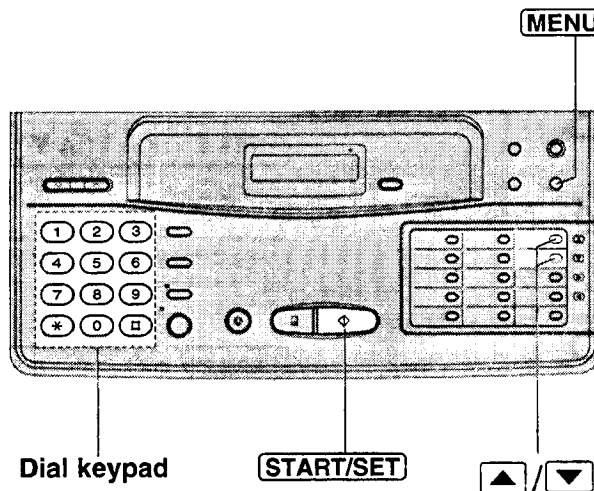

## Changing the display contrast

Use this feature to adjust the brightness of the display.

The following choices are available.

**NORMAL:** (Pre-selected setting)

**LIGHT:** Used when the display contrast is too dark.

**DARKER:** Used when the display contrast is too light.

- 1 Press **MENU**.  
SYSTEM SET UP
- 2 Press **#**, then **39**.  
LCD CONTRAST
- 3 Press **START/SET**.  
MODE=NORMAL [▲▼]
- 4 Press ▲ or ▼ to select the desired setting.
- 5 Press **START/SET**.
- 6 Press **MENU**.

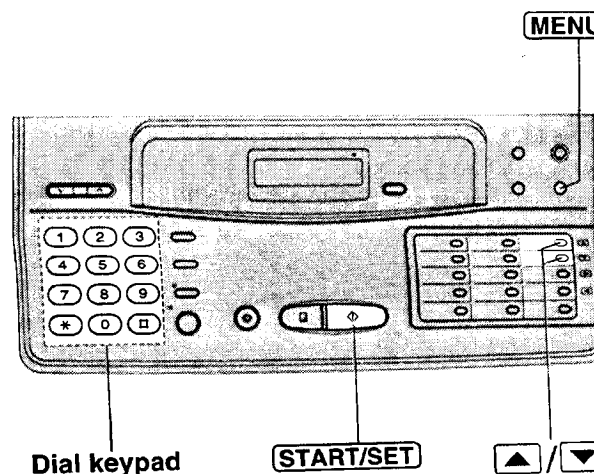

# Resetting the advanced features

Use this feature to return the advanced features (p. 51) to their pre-selected settings.

1 Press **MENU**.  
SYSTEM SET UP

2 Press **#**, then **80**.  
SET DEFAULT

3 Press **START/SET**.  
RESET=NO [▲▼]

4 Press **▲** or **▼** to select "YES".  
RESET=YES [▲▼]

5 Press **START/SET**.  
RESET OK?

•If this feature is not required, press **STOP**.

6 Press **START/SET** again for confirmation.  
RESET COMPLETED

7 Press **MENU**.

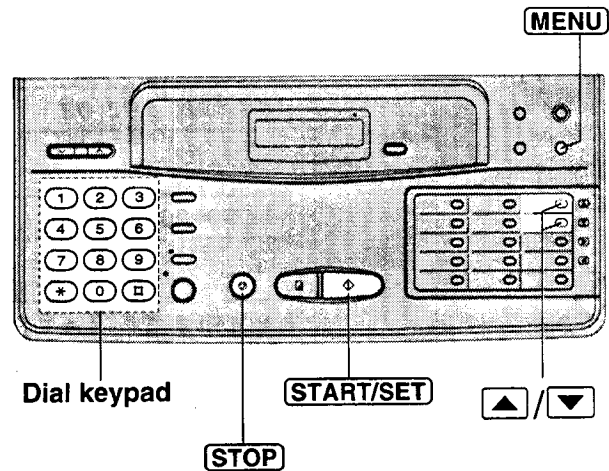

# Summary of user programmable features --- ---

## Basic features

Code	Feature	Selection	Initial setting	Page
#01	SET DATE & TIME	mm/dd/yy hh:mm	(Jan./01/96 12:00 AM)	14
#02	YOUR LOGO			14
#03	YOUR TELEPHONE NUMBER			16
#04	PRINT TRANSMISSION REPORT	ERROR, ON, OFF	OFF	53
#06	TEL/FAX DELAYED RING	1, 2, 3, 4 rings	1 ring	24
#07	FAX RING COUNT	1, 2, 3, 4 rings	1 ring	25
#11	REMOTE TAM ACTIVATION	ON, OFF	OFF/ID=11	36
#14	PC LINK	ON, OFF	ON	18

## Advanced features

Code	Feature	Selection	Initial setting	Page
#21	LOGO POSITION	OUT, IN	OUT	49
#22	JOURNAL AUTO PRINT	ON, OFF	ON	53
#23	OVERSEAS MODE	ON, OFF	OFF	34
#24	JUNK MAIL PROHIBITOR	ON, OFF	OFF/ID=22	37
#25	DELAYED TRANSMISSION	ON, OFF	OFF	33
#30	SILENT FAX RECOGNITION RING	3, 4, 5, 6 rings	3 rings	24
#31	RING DETECTION	OFF, A, B, C, D	OFF	38
#34	EXTENSION COPY			44
#35	COPY REDUCTION	92%, 72%, OFF	OFF	45
#36	RX REDUCTION	92%, 86%, 72%, OFF	92%	42
#38	SILENT DETECTION	ON, OFF	ON	48
#39	LCD CONTRAST	NORMAL, LIGHT, DARKER	NORMAL	49
#41	REMOTE FAX ACTIVATION CODE		* *	36
#44	RECEIVE ALERT	ON, OFF	ON	41
#70	FAX PAGER	ON, OFF	OFF	39
#80	SET DEFAULT	YES, NO	NO	50

# Printing reports and lists

You can print out the following reports/lists from your unit.

**Feature list**—provides you with the current settings of the basic and advanced programming features (p. 51).

**Telephone number list**—provides you with phone numbers and their station names which are stored in automatic dialing. Phone number codes are shown below.

P: A pause has been entered.  
F: A flash has been entered.

[ ]: A secret phone number has been entered.  
(The telephone number is not printed.)

**Journal report**—keeps records of fax transmissions and receptions. This report will be printed automatically after every 35 fax communications, but can be printed manually. You can change the setting of the journal auto print feature (p. 53).

**Print test list**—allows you to check the print quality of your unit. If the test print has a dirty pattern or blurred points or lines, clean the thermal head (p. 64).

**Transmission report**—provides you with a printed record of the fax transmission result (p. 53).

## How to print each report/list

- 1 Press **MENU** until the following is displayed.

PRINT LIST

- 2 For the feature list, press **#**, then **1**.

SETUP LIST

For the telephone number list, press **#**, then **3**.

TEL NO. LIST

For the journal report, press **#**, then **4**.

JOURNAL REPORT

For the printer test list, press **#**, then **5**.

PRINTER TEST

- 3 Press **START/SET** to start printing.

PRINTING

•To interrupt printing, press **STOP**.

- 4 After printing, press **MENU**.

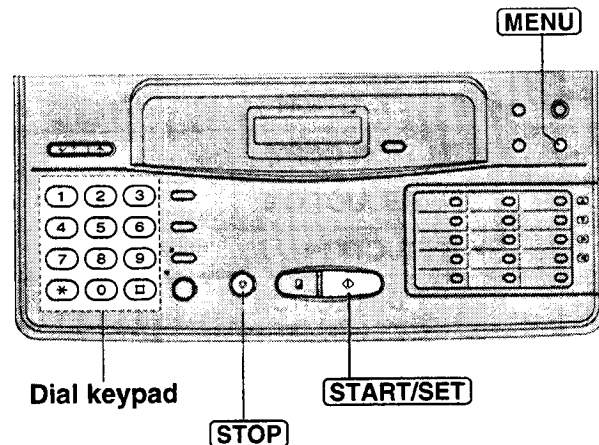

## Setting the transmission report printing

One of the following choices is available.

**ERROR:** The transmission report will print out only when fax transmission fails.

**ON:** The report will always print out, indicating whether fax transmission is successful or not.

**OFF:** The report will not print (pre-selected setting).

- 1 Press **MENU**.  
SYSTEM SET UP
- 2 Press **#**, then **04**.  
TX-REPORT MODE
- 3 Press **START/SET**.  
MODE=OFF [▲▼]
- 4 Press **▲** or **▼** to select the desired mode.
- 5 Press **START/SET**.
- 6 Press **MENU**.

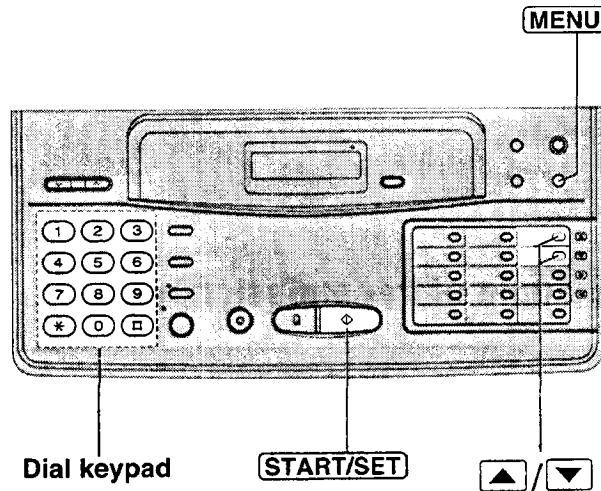

## Setting journal auto print

The unit will automatically print a journal report after every 35 fax communications. After printing, the journal report will still remain in memory and the oldest communication will be erased when a new communication occurs.

When this feature is deactivated, the unit will store the records of the last 35 fax communications, but the unit will not print the journal report automatically.

- 1 Press **MENU**.  
SYSTEM SET UP
- 2 Press **#**, then **22**.  
AUTO JOURNAL
- 3 Press **START/SET**.  
MODE=ON [▲▼]
- 4 Press **▲** or **▼** to select the desired mode.
- 5 Press **START/SET**.
- 6 Press **MENU**.

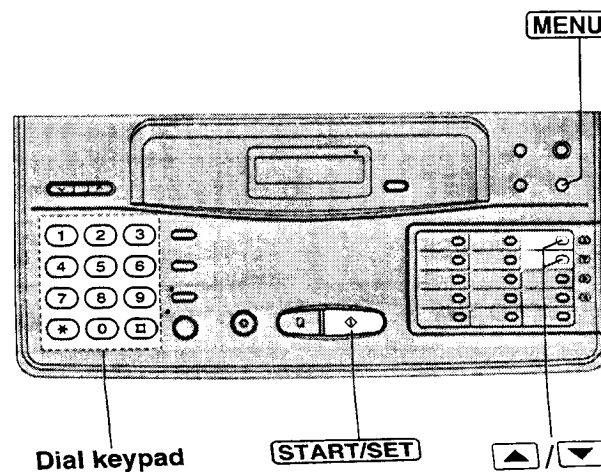

## Sample of journal report

<b>JOURNAL</b>							
Jan. 25 1996 05:22PM							
NO.	OTHER FACSIMILE	START TIME	USAGE TIME	MODE	PAGES	RESULT	*CODE
01	1234567	Jan. 21 02:14PM	00'25	TX	01	OK	
02	9998765	Jan. 21 02:17PM	00'38	TX	02	OK	
03	<< G3 >>	Jan. 21 02:18PM	00'28	RX	01	OK	
04	555556677	Jan. 22 10:35AM	00'58	TX	03	COMMUNICATION ERROR	(43)
05	+987 123		01'50	RX	05	OK	
06					01	OK	

Communication result (see below.)

Error code (for service personnel use only)

## Sample of transmission report

<b>XMT REPORT</b>							
Jan. 20 1996 01:19PM							
NO.	OTHER FACSIMILE	START TIME	USAGE TIME	MODE	PAGES	RESULT	*CODE
01	COMPANY ABC	Jan. 20 01:18PM	00'51	TX	00	COMMUNICATION ERROR	(43)

## Communication result on the report

When a problem has occurred, one of the following messages will be printed on the transmission and journal reports.

PRINTED MESSAGE	MEANING
COMMUNICATION ERROR	A transmission or reception error occurred. Try again or check with the other party.
DOCUMENT JAMMED	A document is jammed. Remove the jammed document (p. 63).
JUNKMAIL PROH. REJECT	The junk mail prohibitor of your unit rejected fax reception.
MEMORY FULL	The document was not received due to memory full.
NO DOCUMENT	The document was not fed into the unit properly. Try again.
NO RESPONSE	The receiving unit was busy or ran out of recording paper. Try again.
PRESSED THE STOP KEY	The STOP button was pressed and fax communication was cancelled.
OK	Fax communication was successful.

# Error messages on the display

If the unit detects a problem, one of the following messages will appear on the display.

ERROR MESSAGE	CAUSE & REMEDY
CALL SERVICE	•There is something wrong with the unit. Contact our service personnel (p. 69).
CHECK CASSETTE	•The recording paper is jammed near the paper cassette. Clear the jammed paper (p. 61).
CHECK COVER	•The top cover is open. Close it.
CHECK DOCUMENT	•The document is not fed into the unit properly. Reinsert the document. If misfeeding occurs frequently, clean the document feeder rollers inside the unit (p. 64). If the problem remains, adjust the feeder pressure (p. 63).
CHECK FILM	•The film is not inserted in the cartridge correctly. Reinsert it correctly by referring to step 8 on page 66.
CHECK MEMORY	•Memory (phone numbers, parameters, etc.) has been erased. Re-program.
FAX IN MEMORY	•The unit has a document(s) in memory. See the other message's instructions to print out the document(s). See page 40.
FILM EMPTY	•Film is empty. Replace the film or film cartridge with a new one (p. 65).
LOADING FILM	•The blue leader of the film was not wound properly or the unit is out of film. Wait for a while.
MEMORY FULL	•The memory is full of received documents due to a lack of recording paper, a recording paper jam, etc. Install paper or clear the jammed paper.
NO RESPONSE	•The receiving unit is busy or ran out of recording paper. Try again.
OUT OF PAPER	•The unit ran out of recording paper. Install paper (p. 9).
PAPER JAMMED	•The recording paper jam occurred near the head unit. Clear the jammed paper (p. 61).
PC FAIL OR BUSY	•The fax function cannot be operated on the PC. The RS232C cable is not connected correctly, or the software is not running on the PC.
POLLING ERROR	•The other fax machine does not have a polling feature. Check with the other party.
REDIAL TIME OUT	•The receiving unit is busy or ran out of recording paper. Try again.
REMOVE DOCUMENT	•The document is jammed. Remove the jammed document (p. 63). •Attempted to transmit a document longer than 600 mm (23 <sup>5</sup> / <sub>8</sub> "). Press the STOP button and remove the document (p. 63). Divide the document into two or more sheets and try again.
TRANSMIT ERROR	•A transmission error occurred. Try again.
UNIT OVERHEATED	•The unit is too hot. Let the unit cool down.

# Before requesting help

## General

PROBLEM	CAUSE & REMEDY
I cannot make and receive calls.	<ul style="list-style-type: none"> <li>•The power cord or telephone line cord is not connected. Check the connection (p. 13).</li> </ul>
I cannot make calls.	<ul style="list-style-type: none"> <li>•The dialing mode setting is wrong. Check the selector (p. 13).</li> </ul>
The unit does not work.	<ul style="list-style-type: none"> <li>•Disconnect the unit from the telephone line and connect to a known working phone. If the working phone operates properly, call your service center to have the unit repaired. If the working phone does not operate properly, contact your telephone company.</li> </ul>
The unit does not ring.	<ul style="list-style-type: none"> <li>•The ringer volume is set to OFF. Adjust to a suitable level (p. 16).</li> </ul>
The REDIAL/PAUSE button does not function properly.	<ul style="list-style-type: none"> <li>•If this button is pressed during dialing, a pause will be inserted. If this button is pressed immediately after obtaining a dial tone, the last number dialed will be redialed.</li> </ul>
During programming, I cannot enter the activation code or the prohibitor ID.	<ul style="list-style-type: none"> <li>•Whole or part of the number is the same as another code or ID. Change the number (p. 36, 37 and 47).</li> </ul>

## Fax Transmission

PROBLEM	CAUSE & REMEDY
The other party complains that letters on their received document are distorted.	<ul style="list-style-type: none"> <li>•If your line has special telephone services such as call waiting, the service may have been activated during fax transmission. Connect the unit to a line that does not have such services.</li> <li>•An extension telephone that is connected to the same line is off hook. Hang up and try again.</li> </ul>
The other party complains that dirty patterns or black lines appear on their received documents.	<ul style="list-style-type: none"> <li>•The glass or rollers are dirty. Clean them (p. 64).</li> </ul>
I cannot make an international fax call.	<ul style="list-style-type: none"> <li>•Use the overseas transmission mode (p. 34).</li> <li>•Add two pauses at the end of the phone number (p. 31).</li> </ul>

## Fax Reception

PROBLEM	CAUSE & REMEDY
I cannot receive documents automatically.	<ul style="list-style-type: none"> <li>•The receive mode is set to TEL. Set to TEL/FAX or FAX (or EXT. TAM).</li> <li>•The time to answer the call may be too long. Decrease the number of rings (p. 24 and 25).</li> <li>•The junk mail prohibitor is set to ON (p. 37).</li> </ul>



PROBLEM	CAUSE & REMEDY
Recording image is faint.	<ul style="list-style-type: none"> <li>•The sender transmitted a faint document. Request them to transmit a clearer copy of the document.</li> <li>•The thermal head is dirty. Clean it (p. 64).</li> </ul>
A blank sheet is ejected after the received documents are printed out.	<ul style="list-style-type: none"> <li>•The receiving reduction rate is not programmed correctly. Program the proper reduction rate (p. 42).</li> </ul>

### Operation in EXT. TAM mode

PROBLEM	CAUSE & REMEDY
I cannot receive documents automatically.	<ul style="list-style-type: none"> <li>•Your greeting message is too long. Shorten it (up to 10 seconds).</li> <li>•There are too many rings on the answering machine. Set the number of rings to less than 3.</li> <li>•The silent detection feature is deactivated. Activate this feature (p. 48).</li> </ul>
I cannot receive voice messages.	<ul style="list-style-type: none"> <li>•Check that the answering machine is turned on and connected to the facsimile unit properly (p. 46).</li> <li>•Set the number of rings on the answering machine to less than 3.</li> </ul>
I cannot retrieve voice messages on the answering machine from a remote location.	<ul style="list-style-type: none"> <li>•The remote access code on your answering machine is the same as the remote fax activation code or the junk mail prohibitor ID on the facsimile unit. Set a different number for each code/ID.</li> <li>•Your remote TAM activation code is not programmed correctly. Program the same code as on the answering machine (p. 47).</li> </ul>
The greeting message on your answering machine is interrupted and the caller cannot leave a voice message.	<ul style="list-style-type: none"> <li>•The silent pause in the greeting message is too long. Shorten it to less than 4 seconds.</li> </ul>
I pressed the remote access code to access the answering machine remotely, but the line was disconnected.	<ul style="list-style-type: none"> <li>•The code may include “#” which is used for certain features offered by telephone companies. Change the code on the answering machine so that it does not include “#”. Then program the same code into the facsimile unit (p. 47).</li> </ul>

### Copying

PROBLEM	CAUSE & REMEDY
Dirty patterns or black lines appear on the copied documents.	<ul style="list-style-type: none"> <li>•The glass or rollers are dirty. Clean them (p. 64).</li> </ul>
The copied image is distorted.	<ul style="list-style-type: none"> <li>•The thermal head is dirty. Clean it (p. 64).</li> </ul>
The document is not copied properly.	<ul style="list-style-type: none"> <li>•The film is not inserted correctly. Insert it correctly (p. 65).</li> </ul>
A paper jam occurs during copying.	<ul style="list-style-type: none"> <li>•The film is not inserted correctly. Insert it correctly (p. 65).</li> </ul>

# Error codes on your PC when using Multi Function Center software

If an error occurred when functioning the printer or scanner using Multi Function Center software on your PC, the error code is shown in the 8 digits on the Status Log window as follows.

The meaning of each digit of the error code is different according to the function you are using. If an error occurred using the printer function, see below. In case of using the scanner function, see page 59.

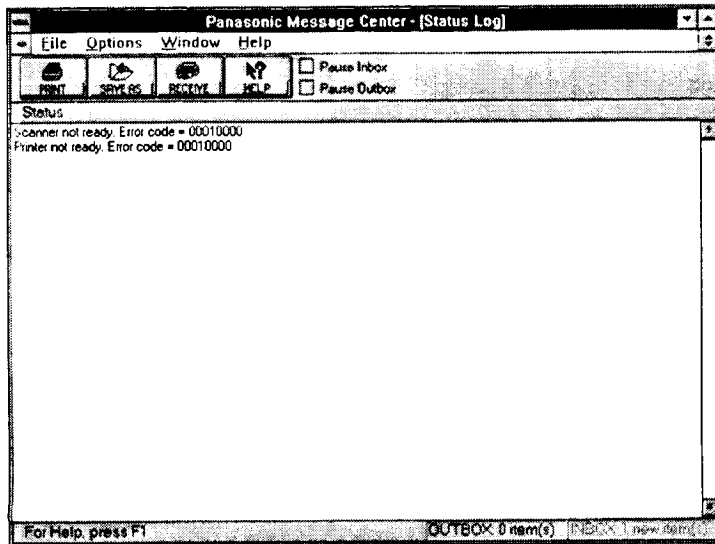

## ■ Error code in the status of “Printer not ready.”:



### Paper:

When this digit is “1”, the unit ran out of paper. Install paper.

### Paper jam near the paper cassette:

When this digit is “1”, the recording paper is jammed near the paper cassette. Clear the jammed paper (p. 62).

### Paper jam near the head unit:

When this digit is “1”, the recording paper jam occurred near the head unit. Clear the jammed paper (p. 61).

### Cover open:

When this digit is “1”, the top cover is open. Close it

### Film:

When this digit is “1”, film is empty or the film is not inserted in the cartridge correctly. Replace the film or film cartridge with a new one (p. 65) or reinsert the film correctly by referring to step 8 on page 66.

### Unit overheat:

When this digit is “1”, the unit is overheated. Leave it to cool down.

■ Error code in the status of “Scanner not ready.”:



**Document feed:**  
When this digit is “1”, the document is not fed into the unit properly. Reinsert the document.

**Document jam:**  
When this digit is “1”, the document is jammed. Remove the jammed document (p. 63).

**Cover open:**  
When this digit is “1”, the top cover is open. Close it.

**For example:**

There are one or some “1” in 8 digits of an error code.  
See the instructions of the digit in which “1” is shown and solve the problem.

e.g. When “Scanner not ready. Error code = 00010000” is displayed on the Status Log window:



In this case, see the instructions of the digit in which “1” is shown on the Error code in the status of “Scanner not ready.” on this page. The problem is the top cover is open. Close the top cover.

When “Printer not ready. Error code” is displayed on the Status Log window, see the instructions of the digit in which “1” is shown on the Error code in the status of “Printer not ready.” on page 58.

## If a power failure occurs... --- ---

When a power failure occurs, note the following:

- Transmission and reception will be interrupted. Check the transaction by printing a journal report.
- If fax documents are stored in memory, they will be lost. When power is restored, a power-down report will be printed out stating the contents in memory that have been cleared.
- If delayed transmission is set and the programmed start time has passed during a power failure, the transmission will be attempted soon after power is restored.
- If an external telephone/telephone answering machine is connected to the unit, you can use it during a power failure.

## Power-down report ---

The power-down report will be automatically printed out after power is restored.  
The report will not be printed out when there are no documents stored in memory.

### Sample of the power-down report

<u>POWER DOWN REPORT</u>				
POWER DOWN AT:Jan. 05 1996 04:30AM				
RESTARTED AT:Jan. 05 1996 04:31AM				
<< WARNING >>				
CONTENTS HAVE BEEN CLEARED DUE TO POWER DOWN.				
FOR ADDITIONAL INFORMATION, PLEASE SEE THE JOURNAL REPORT.				
NO.	OTHER FACSIMILE	MODE	PAGES	FUNCTION
01	0987654321	RX	01	MEMORY RECEIVE

## If a problem occurs during reception --- ---

If a problem occurs during reception, the unit will stop printing. When the problem is resolved, the unit will print a print error report to let you know which page of data was cleared. If there is a continuation of the documents, the unit will print from the next page.

### Sample of the print error report

<u>PRINT ERROR REPORT</u>					
Jan. 01 1996 02:46AM					
<< WARNING >>					
CONTENTS HAVE BEEN CLEARED WITHOUT PRINTING OUT.					
NO.	OTHER FACSIMILE	START TIME	USAGE TIME	MODE	PAGE
01	092 431 2111	Jan. 01 02:39AM	03'17	RX	01

Cleared page

# Clearing a recording paper jam

If the unit does not eject any recording paper during reception or copying or printing, the recording paper has jammed and the display will show one of the following two messages. Remove the jammed paper following the displayed message.

PAPER JAMMED

A recording paper jammed near the head unit. See below.

CHECK CASSETTE

A recording paper jammed near the paper cassette. See page 62.

## When paper has jammed near the head unit

- 1 Open the top cover.
- 2 Press both green buttons marked "PUSH" and lift up the head unit.

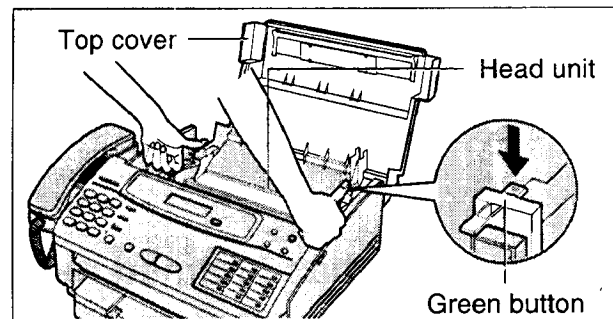

- 3 Remove the film cartridge.
- 4 Remove the paper cassette by (A) slightly lifting and (B) pulling it out of the unit.

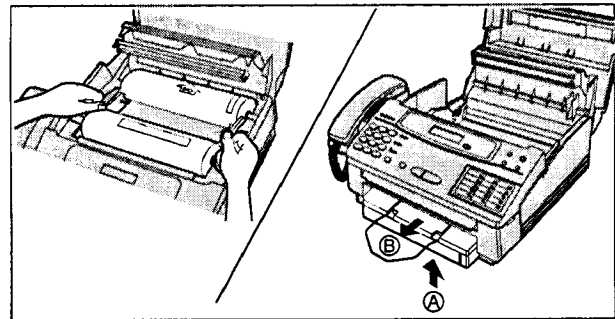

- 5 Remove the jammed recording paper.
  - If the jammed paper cannot be removed as shown in the left illustration, then remove it as shown below:

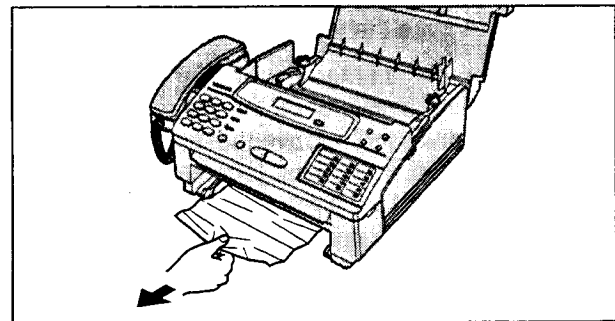
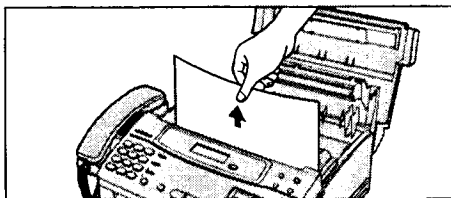

- 6 Place the "BACK" side of the cartridge into the unit by inserting the side pins of the green gears into the green holders. Then lower the front of the cartridge into place.
  - If the film is slack, tighten it by winding the gears.

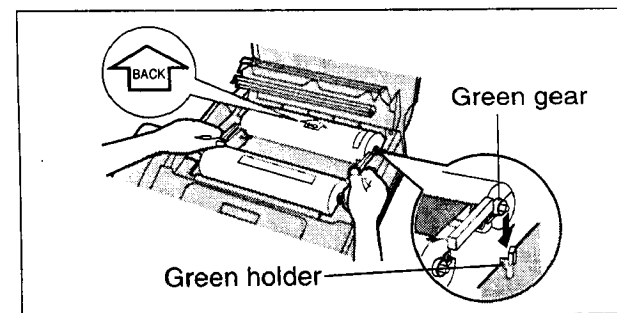

7 Press the head unit down firmly until it clicks into place.

8 Close the top cover securely by pushing down on both sides.

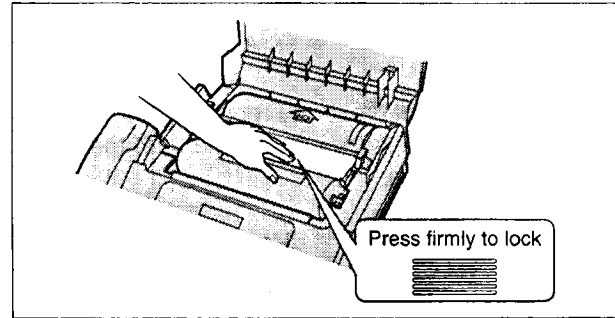

9 Open the paper cassette cover, remove the paper, press down the silver plate until it is locked under the tab and insert the paper into the paper cassette (see steps 2-6 on pages 9 and 10 for details).

10 Insert the paper cassette into the unit until it clicks into place.

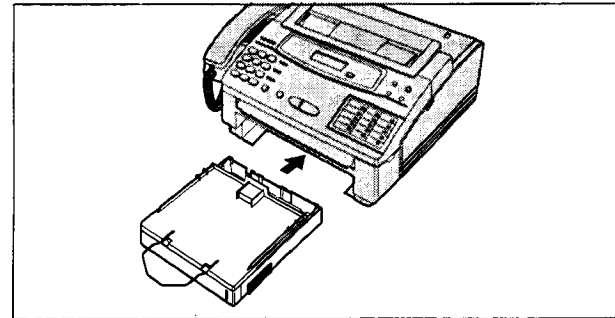

## When paper has jammed near the paper cassette

1 Remove the paper cassette by (A) slightly lifting and (B) pulling it out of the unit.

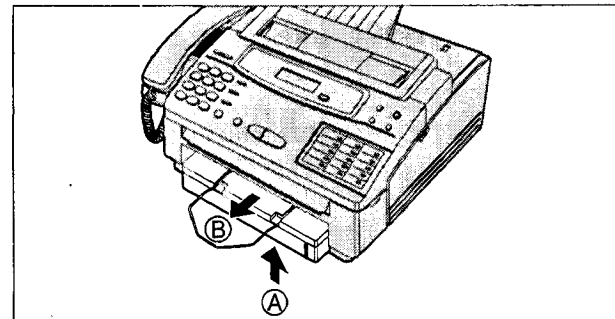

2 Reach into the paper cassette opening and remove the jammed recording paper.

- When the jammed paper cannot be removed easily, open the top cover, head unit, and remove the jammed paper. Do not pull the jammed paper forcibly, or torn pieces of paper may remain in the unit.

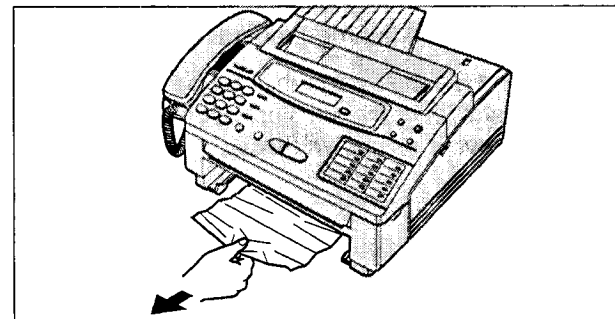

3 Open the paper cassette cover, remove the paper, press down on the silver plate until it is locked under the tab and insert the paper into the paper cassette (see steps 2-6 on pages 9 and 10 for details).

4 Insert the paper cassette into the unit until it clicks into place.

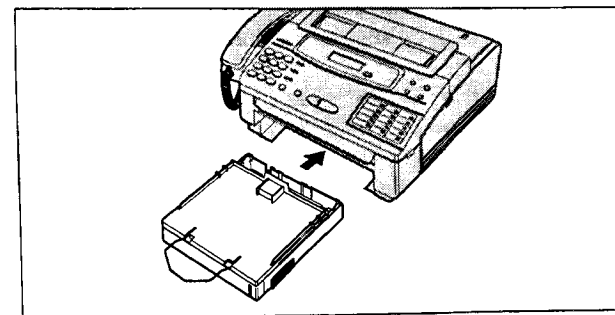

## Clearing a document jam

If the unit does not release the original document during feeding, remove the document as follows.

- 1 Slide the front lid open lever toward the front to open the front lid.
- 2 Remove the jammed document carefully.
- 3 Close the front lid securely by pushing down on both sides.

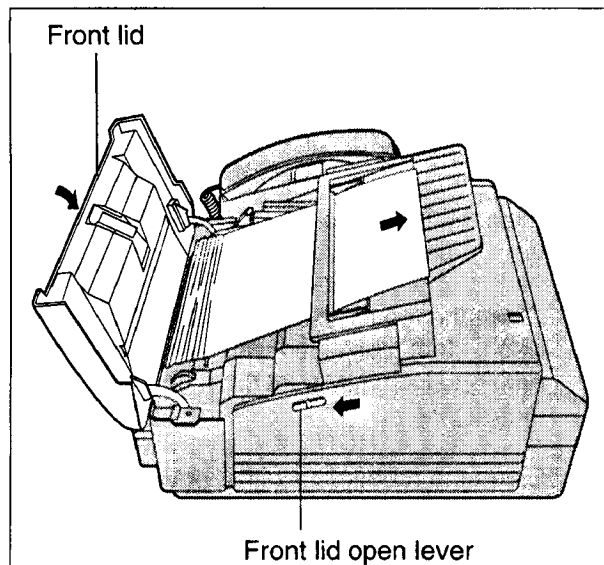

## Adjusting the feeder pressure

If misfeeding of documents, such as no feeding or multiple feeding, occurs frequently, adjust the feeder pressure by following the steps below.

- 1 Slide the front lid open lever toward the front to open the front lid.
- 2 Shift the position of the lever by using an instrument with a pointed end, like a clip or ball-point pen.  
  
Position A: Select this when documents do not feed.  
Position B: Standard position (pre-selected)  
Position C: Select this when documents multiple feed.
- 3 Close the front lid securely by pushing down on both sides.

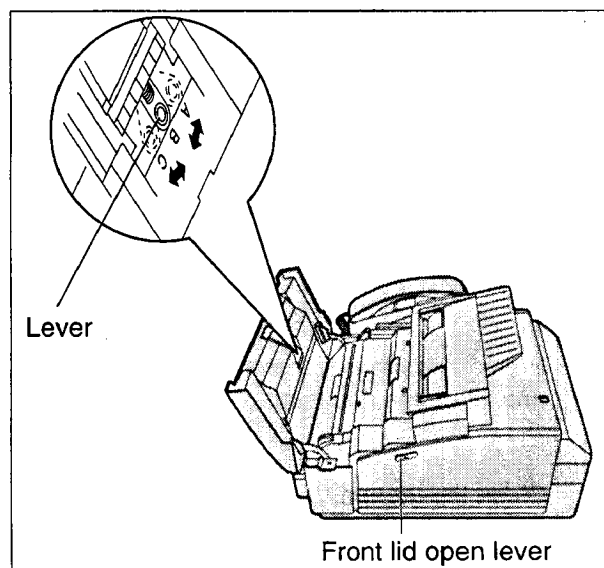

# Cleaning the inside of the unit

## Cleaning the document feeder unit

If misfeeding occurs frequently or dirty patterns or black bands appear on a copied, transmitted or printed document, clean the feeder rollers, sub roller, rubber flap, white plate and glass.

- 1 Disconnect the power cord and the telephone line cord.
- 2 Slide the front lid open lever toward the front to open the front lid.
- 3 Clean the feeder rollers and sub roller with a cloth moistened with isopropyl rubbing alcohol, and let them dry thoroughly.
- 4 Clean the rubber flap with a cotton swab moistened with isopropyl rubbing alcohol, and let it dry thoroughly.
- 5 Clean the white plate and the glass with a soft dry cloth.
- 6 Close the lid securely by pushing down on both sides.
- 7 Connect the power cord and telephone line cord.

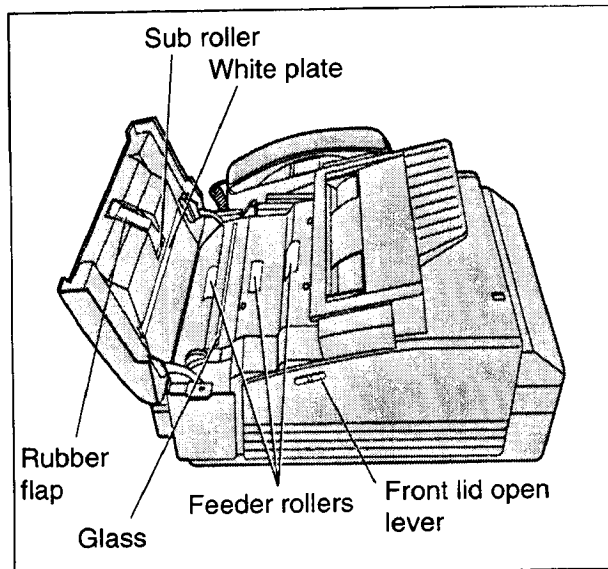

## Cleaning the thermal head

If dirty patterns or black bands appear on a copied or received document, clean the thermal head.

- 1 Disconnect the power cord and the telephone line cord.
- 2 Open the top cover.
- 3 Press both green buttons marked "PUSH" and lift up the head unit.
- 4 Clean the thermal head with a cloth moistened with isopropyl rubbing alcohol, and let it dry thoroughly.
- 5 Press the head unit down firmly until it clicks into place.
- 6 Close the top cover securely by pushing down on both sides.
- 7 Connect the power cord and telephone line cord.

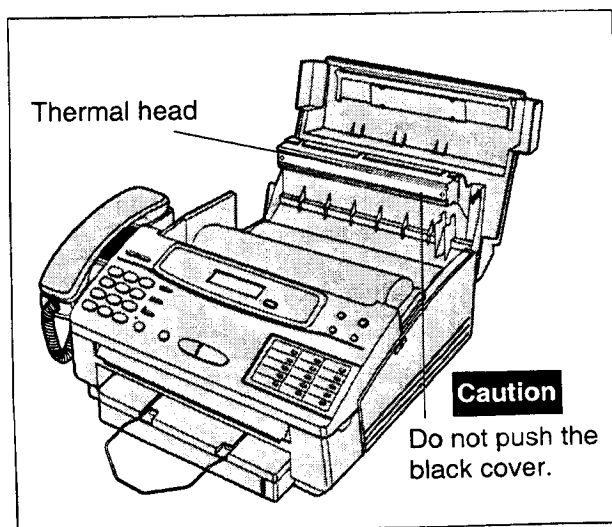

### Caution:

- To prevent a malfunction due to static electricity, do not use a dry cloth and do not touch the thermal head directly with your finger.



# Replacing the film or film cartridge

When the unit detects the end of the film, the following message will be displayed.

FILM EMPTY

Replace the film or film cartridge with a new one. To order replacement parts, see page 70.

- 1 Open the top cover.
- 2 Press both green buttons marked "PUSH" and lift up the head unit.

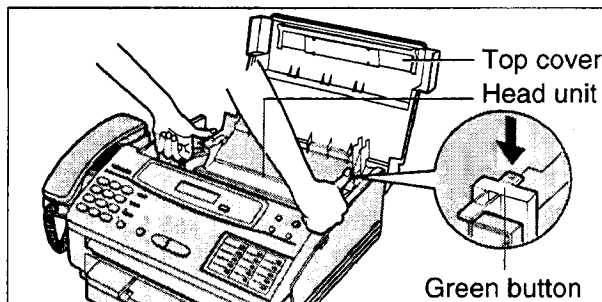

- 3 Remove the film cartridge.
  - If you have purchased a film cartridge (Model no. KX-FA132) for replacement, skip to step 11.
  - To replace only the film, go to step 4.

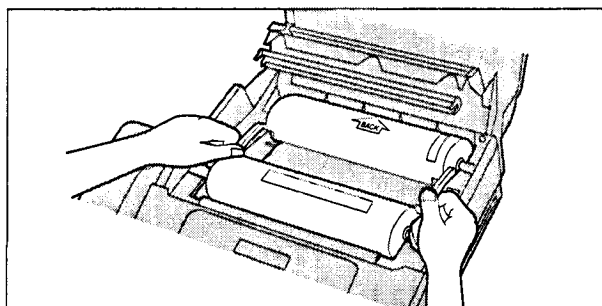

- 4 Turn over the cartridge so that the "PULL TAB" mark is facing up.
- 5 Unlock the four tabs of the cartridge, open the cover of the cartridge and remove the used film.

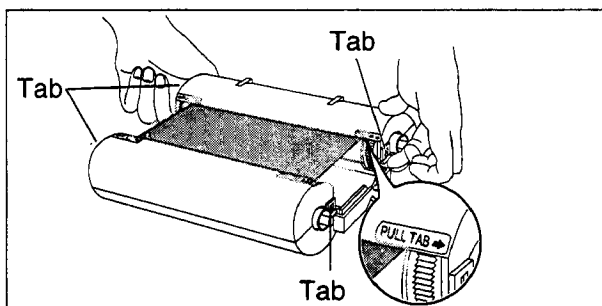

- 6 Remove the four gears from the used film cores by pulling them out.

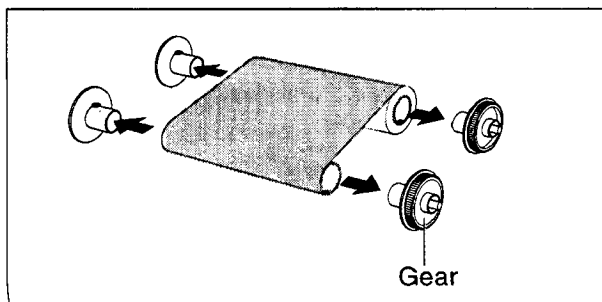

- 7 Insert the four gears into the new film cores so that the guide tab of each gear fits into the slot of the film core.

### Caution:

- The film is not reusable. You can order a new film for replacement through your nearest Panasonic dealer.

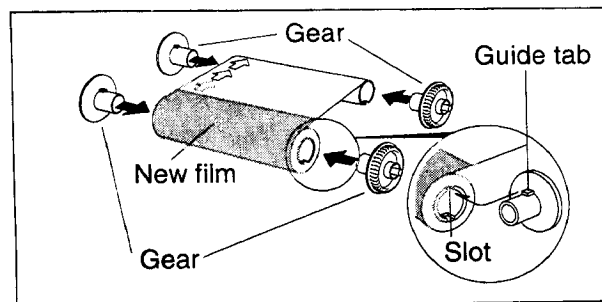

Troubleshooting  
and Routine Care

- 8** Insert the film into the cartridge so that the arrow on the open cartridge points in the same direction as the arrows on the film.
- If you insert a film which is partially used, insert the unused spool of the film in the "FILM SUPPLY" mark side of the cartridge.

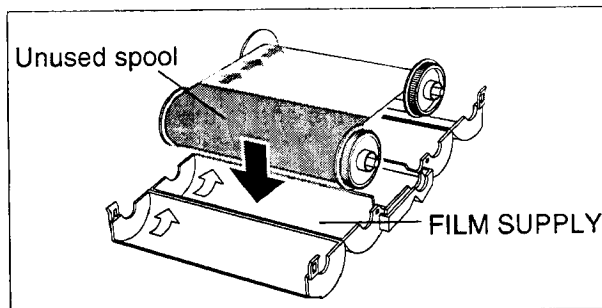
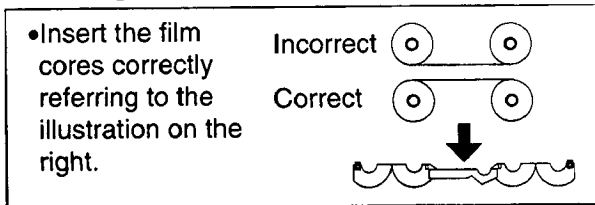

- 9** Roll the blue leader of the film by winding the core gears until the leader is no longer visible.

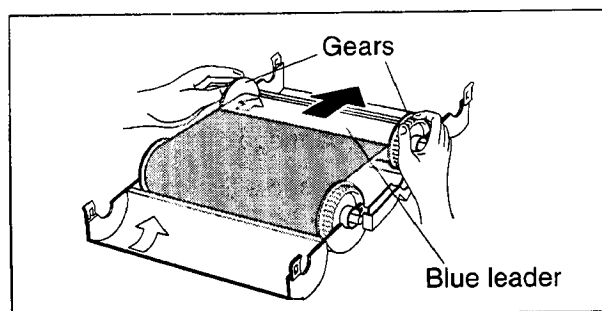

- 10** Close the covers of the cartridge by locking the four tabs.

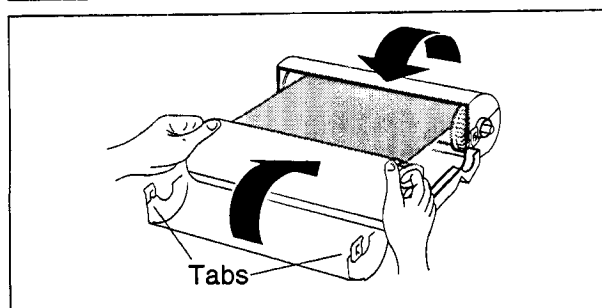

- 11** Turn over the cartridge and referring to the illustration on the left, place the "BACK" side of the cartridge into the unit by inserting the side pins of the green gears into the green holders. Then lower the front of the cartridge into place.

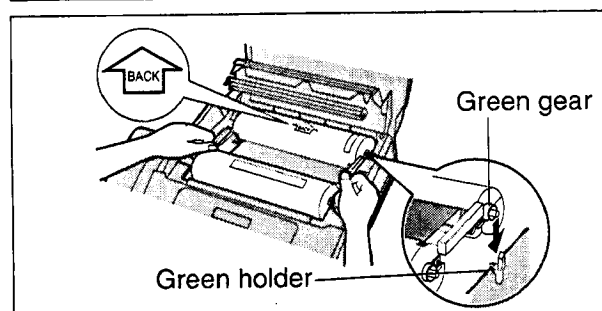

- 12** Press the head unit down firmly until it clicks into place.

- 13** Close the top cover securely by pushing down on both sides.
- If the blue leader of the film is not wound completely, the unit will automatically advance it and the following message will be displayed.

LOADING FILM

- If the following message is displayed, the film is not correctly inserted in the cartridge.

CHECK FILM

- Reinsert it correctly by referring to step 8 above.

# FCC information

---

If required by the telephone company, inform them of the following.

- FCC Registration No. :  
(found on the rear side of the unit)
- Ringer Equivalence No.:  
(found on the rear side of the unit)
- The particular telephone line to which the equipment is connected.

This unit must not be connected to a coin operated line. If you are on a party line, check with your local telephone company.

## **Ringer Equivalence Number (REN):**

This REN is useful in determining the quantity of devices you may connect to your telephone line and still have all of those devices ring when your telephone number is called. In most but not all areas, the sum of the REN's of all devices connected to one line should not exceed five (5.0). To be certain of the number of devices you may connect to your line, as determined by the REN, you should contact your local telephone company to determine the maximum REN for your calling area.

In the event that terminal equipment causes harm to the telephone network, the telephone company should notify the customer, if possible, that service may be stopped. However, where prior notice is impractical, the company may temporarily cease service providing that they:

- a) Promptly notify the customer.
- b) Give the customer an opportunity to correct the problem with their equipment.
- c) Inform the customer of the right to bring a complaint to the Federal Communication Commission pursuant to procedures set out in FCC Rules and Regulations Subpart E of Part 68.

The Telephone Company may make changes in its communications facilities, equipment operations, or procedures where such action is reasonably required in the operation of its business and is not inconsistent with the rules and regulations in FCC Part 68. If such changes can be reasonably expected to render any customer terminal equipment incompatible with telephone company communications facilities, or require modification or

alteration of such terminal equipment, or otherwise materially affect its use or performance, the customer shall be given adequate notice in writing, to allow the customer an opportunity to maintain uninterrupted service.

## **CAUTION:**

Any changes or modifications not expressly approved by the party responsible for compliance could void the user's authority to operate this device.

When programming emergency numbers and/or making test calls to emergency numbers:

1. Remain on the line and briefly explain to the dispatcher the reason for the call before hanging up.
2. Perform such activities in the off-peak hours; such as early morning or late evenings.

This telephone provides magnetic coupling to hearing aids.

## **NOTE:**

This equipment has been tested and found to comply with the limits for a Class B digital device, pursuant to Part 15 of the FCC Rules. These limits are designed to provide reasonable protection against harmful interference in a residential installation. This equipment generates, uses, and can radiate radio frequency energy and, if not installed and used in accordance with the instructions, may cause harmful interference to radio communications. However, there is no guarantee that interference will not occur in a particular installation. If this equipment does cause harmful interference to radio or television reception, which can be determined by turning the equipment off and on, the user is encouraged to try to correct the interference by one or more of the following measures:

- Reorient or relocate the receiving antenna.
- Increase the separation between the equipment and receiver.
- Connect the equipment into an outlet on a circuit different from that to which the receiver is connected.
- Consult the dealer or an experienced radio/TV technician for help.

Matsushita Consumer Electronics Company,  
Division of Matsushita Electric Corporation of America  
One Panasonic Way, Secaucus,  
New Jersey 07094

Panasonic Sales Company ("PSC")  
Division of Matsushita Electric of  
Puerto Rico, Inc.  
Ave. 65 de Infantería, Km. 9.5, San Gabriel  
Industrial Park, Carolina, Puerto Rico 00985

## PANASONIC Facsimile Products Limited Warranty

Matsushita Consumer Electronics Company or Panasonic Sales Company (collectively referred to as "the warrantor") will repair this product with new or refurbished parts, free of charge, in the USA or Puerto Rico for one (1) year from the date of original purchase in the event of a defect in materials or workmanship.

**Batteries** (when applicable)—New rechargeable batteries in exchange for defective rechargeable batteries for ten (10) days from the date of original purchase. Non-rechargeable batteries are not warranted.

Carry-in or mail-in service in the USA or Puerto Rico can be obtained during the warranty period by contacting a Matsushita Services Company (MSC) Factory Servicenter listed in the Servicenter Directory. Or call, toll free, 1-800-HELP FAX (1-800-435-7329) to locate a MSC Factory Servicenter. Carry-in or mail-in service in Puerto Rico can be obtained during the warranty period by calling the local telephone number in the Servicenter Directory.

This warranty is extended only to the original purchaser. A purchase receipt or other proof of date of original purchase will be required before warranty service is rendered.

This warranty only covers failures due to defects in materials and workmanship which occur during normal use and (when applicable) does not cover the print and ink cartridge, the toner cartridge and drum unit or the film cartridge. The warranty does not cover damages which occurred in shipment, or failures which are caused by products not supplied by the warrantor, or failures which result from accident, misuse, abuse, neglect, mishandling, faulty installation, misapplication, set-up adjustments, improper operation or maintenance, alteration, modification, line power surge, improper voltage supply, lightning damage, signal reception problems, commercial use such as hotel, office, restaurant, or other business or rental use of product, or serviced by anyone other than a MSC Factory Servicenter or a MSC authorized Servicenter, or damage that is attributable to acts of God.

### **LIMITS AND EXCLUSIONS**

There are no express warranties except as listed above.

THE WARRANTOR SHALL NOT BE LIABLE FOR INCIDENTAL OR CONSEQUENTIAL DAMAGES RESULTING FROM THE USE OF THIS PRODUCT, OR ARISING OUT OF ANY BREACH OF THIS WARRANTY. ALL EXPRESS AND IMPLIED WARRANTIES, INCLUDING THE WARRANTIES OF MERCHANTABILITY, ARE LIMITED TO THE APPLICABLE WARRANTY PERIOD SET FORTH ABOVE.

Some states do not allow the exclusion or limitation of incidental or consequential damages, or limitations on how long an implied warranty lasts, so the above exclusions or limitations may not apply to you.

This warranty gives you specific legal rights and you may also have other rights which vary from state to state. If a problem with this product develops during or after the warranty period, you may contact your dealer or Servicenter. If the problem is not handled to your satisfaction, then write to the Customer Satisfaction Center at the company address indicated above.

# Service center directory

## OPERATION ASSISTANCE • FAX ADVANTAGE PROGRAM

DIAL TOLL FREE: 1-800-HELP-FAX (9:00am - 8:00pm Monday - Friday, EST)

## PRODUCT INFORMATION • LITERATURE REQUESTS • DEALER LOCATIONS

Customer Satisfaction Center 2F-3, One Panasonic Way, Secaucus, NJ 07094 (Headquarters)  
201-348-9090 (9:00am-8:00pm Monday-Friday, EST)

## ACCESSORY PURCHASES

1-800-332-5368 (Consumer orders only)

**Matsushita Services Company** Accessory Order Office, 20421-84th Avenue South Kent, WA 98032  
(6:00am-6:00pm Monday-Friday, 6:00am-10:30am Saturday, PST)  
(Visa, Mastercard, Discover card, American Express, Check)

## AUTHORIZED SERVICENTERS

### CALIFORNIA

6550 Katella Avenue  
Cypress, CA 90630  
Phone (714) 373-7425  
Fax (714) 894-8534

800 Dubuque Avenue  
S. San Francisco,  
CA 94080  
Phone (415) 871-6373  
Fax (415) 871-6840

20201 Sherman Way  
Suite 102  
Canoga Park, CA 91306  
Phone (818) 709-1775  
Fax (818) 709-2165

3878 Ruffin Road  
Suite A  
San Diego, CA 92123  
Phone (619) 560-9200  
Fax (619) 560-1831

### COLORADO

1640 South Abilene Suite D  
Aurora, CO 80012  
Phone (303) 752-2024  
Fax (303) 752-0610

### FLORIDA

3700 North 29th Avenue  
Suite 102  
Hollywood, FL 33020  
Phone (954) 925-2880  
Fax (954) 925-5224

4710 Eisenhower  
Boulevard Suite A1  
Tampa, FL 33634  
Phone (813) 884-4746  
Fax (813) 886-4564

### GEORGIA

8655 Rosewell Road  
Suite 100  
Atlanta, GA 30350  
Phone (770) 518-6301  
Fax (770) 518-6306

### HAWAII

99-859 Iwaiwa Street  
Aiea, Hawaii 96701  
Phone (808) 488-1996  
Fax (808) 486-4369

### ILLINOIS

\*1703 North Randall Road  
Elgin, IL 60123  
"12:30 to 4:30, Mon-Fri"  
Phone (847) 468-5464  
Fax (847) 468-5465

9060 Golf Road  
Niles, IL 60714  
Phone (847) 608-1010  
Fax (847) 299-1710

### MARYLAND

Sulphur Springs  
Business Park  
1638 Sulphur Springs Road  
Baltimore, MD 21227  
Phone (410) 242-2607  
Fax (410) 247-3047

### MASSACHUSETTS

60 Glacier Drive, Suite G  
Westwood, MA 02090  
Phone (617) 329-4280  
Fax (617) 329-0586

\*pick-up/drop-off only

### MICHIGAN

37048 Van Dyke Avenue  
Sterling Heights, MI 48312  
Phone (810) 939-2060  
Fax (810) 939-2638

### MINNESOTA

7850-12th Avenue South  
Airport Business Center  
Bloomington, MN 55425  
Phone (612) 854-8624  
Fax (612) 854-2089

### OHIO

2236 Waycross Road  
Cincinnati, OH 45240  
Phone (513) 851-4180  
Fax (513) 851-8443

### PENNSYLVANIA

2221 Cabot Boulevard West  
Suite B  
Langhorne, PA 19047  
Phone (215) 741-0661  
Fax (215) 741-0521

Chartiers Valley  
Shopping Center  
1025 Washington Pike  
Bridgeville, PA 15017  
Phone (412) 257-4522  
Fax (412) 257-4650

### TENNESSEE

919-8th Avenue South  
Nashville, TN 37203  
Phone (615) 244-4434  
Fax (615) 244-6713

### TEXAS

7482 Harwin Drive  
Houston, TX 77036  
Phone (713) 781-1528  
Fax (713) 781-0643

13615 Welch Road Suite 101  
Farmers Branch, TX 75244  
Phone (214) 385-1975  
Fax (214) 960-7626

### WASHINGTON

20425-84th Avenue South  
Kent, WA 98032  
Phone (206) 872-7922  
Fax (206) 872-0918

### Service in Puerto Rico

**Matsushita Electric  
of Puerto Rico, Inc.  
Panasonic Sales Company/  
Factory Servicer**

Ave. 65 de Infanteria, Km. 9.5  
San Gabriel Industrial Park  
Carolina, Puerto Rico 00985  
Phone (809) 750-4300  
Fax (809) 768-2910

## REPAIR INQUIRIES

## Regional Customer Care Department

### EAST (PCE)

2221 Cabot Boulevard West  
Suite A  
Langhorne, PA 19047  
Phone (215) 741-0676  
Fax (215) 750-6492

#### Covers:

CT, DE, ME, MD, MA, NH,  
NJ, NY, PA, RI, VT, VA, DC,  
WV

### EAST (PCE)

1225 Northbrook Parkway  
Suite 2-390  
Suwanee, GA 30174  
Phone (404) 338-6860  
Fax (404) 338-6548

#### Covers:

AL, FL, GA, MS, NC, SC, TN

### CENTRAL (PCC)

1707 North Randall Road  
Elgin, IL 60123  
Phone (847) 468-5530  
Fax (847) 468-5528

#### Covers:

AR, IL, IN, IA, KS, KY, LA,  
MI, MN, MO, NE, ND, OK,  
SD, TX, WI, OH

### WEST (PCW)

6550 Katella Avenue  
Cypress, CA 90630  
Phone (714) 373-7440  
Fax (714) 373-7447

#### Covers:

AK, AZ, CA, CO, ID, MT, NV,  
NM, OR, UT, WA, WY, HI

## PARTS DISTRIBUTION LOCATIONS

To locate parts distributors in your area (within the USA)  
DIAL TOLL FREE 1-800-545-2672 (24 hours a day, 7 days a week)

(960712)

## Information for users

---

---

### For product service

- Service centers are listed on page 69.
- Call toll free 1-800-545-2672 for the location of an authorized service center.

### When you ship the product

- Carefully pack your unit, preferably in the original carton.
- Attach a letter, detailing the symptom or problem, to the outside of the carton.
- Send the unit to an authorized service center, prepaid and adequately insured.
- Do not send your unit to the Matsushita Consumer Electronics Company or to any executive or regional sales offices. These locations do not repair consumer products.

## Accessory order information

---

---

Use the following for replacement. For accessory order, call toll free 1-800-332-5368.  
Problems will occur if other brands of films are used.

Model No.	Description	Comment
KX-FA132	Film cartridge	1 cartridge & 1 film: 216 mm × 200 m (8 $\frac{1}{2}$ " × 656') roll
KX-FA133	Replacement film (1 set)	216 mm × 200 m (8 $\frac{1}{2}$ " × 656') roll
KX-FA134	Replacement film (2 sets)	216 mm × 200 m (8 $\frac{1}{2}$ " × 656') roll

# Specifications

## ■ General

1. Applicable Lines:	Public Switched Telephone Network
2. Document Size:	Max. 216 mm (8 $\frac{1}{2}$ " ) in width Max. 600 mm (23 $\frac{5}{8}$ " ) in length
3. Effective Scanning Width:	208 mm (8 $\frac{3}{16}$ " )
4. Recording Paper Size:	Letter: 216 × 279 mm (8 $\frac{1}{2}$ " × 11" ) Legal: 216 × 356 mm (8 $\frac{1}{2}$ " × 14" )
5. Effective Printing Width:	208 mm (8 $\frac{3}{16}$ " )
6. Transmission Time:	Approx. 15 sec./page* (Original mode) Approx. 30 sec./page (G3 Normal mode)
7. Memory Capacity:	Approx. 28 pages of document memory**
8. Fax Auto Redial:	Up to 5 times
9. Telephone Auto Redial:	Up to 14 times
10. Scanning Density:	Horizontal: 8 pels/mm (203 pels/inch) Vertical: 3.85 lines/mm (98 lines/inch) — Standard Mode 7.7 lines/mm (196 lines/inch) — Fine/Halftone Mode 15.4 lines/mm (392 lines/inch) — Superfine Mode
11. Halftone Level:	64-level
12. Scanner Type:	CCD Image Sensor
13. Printer Type:	Thermal Transfer
14. Data Compression System:	Modified Huffman (MH), Modified READ (MR)
15. Modem Speed:	9600/7200/4800/2400 bps; Automatic Fallback
16. Operating Environment:	5 – 35 °C (41 – 95 °F), 20 – 80 % RH (Relative Humidity)
17. Dimensions (H×W×D):	237 × 420 × 389 mm (9 $\frac{5}{16}$ " × 16 $\frac{9}{16}$ " × 15 $\frac{5}{16}$ " )
18. Mass (Weight):	Approx. 8.2 kg (18 lb.)
19. Power Consumption:	Transmission: Approx. 17 W / Reception: Approx. 40 W Copy: Approx. 50 W / Standby: Approx. 5 W Maximum: Approx. 140 W
20. Power Supply:	120 V AC, 60 Hz (This unit will not function at 50 Hz.)

\*Transmission speed depends upon the contents of the pages, resolution, telephone line conditions and capability of receiving unit. 15 second speed based upon CCITT No.1 Test Chart.

\*\*350 KB memory. Actual number of pages depends upon the contents of the pages and the resolution. 28 page capacity based upon CCITT No.1 Test Chart.

CCITT No. 1 Test Chart

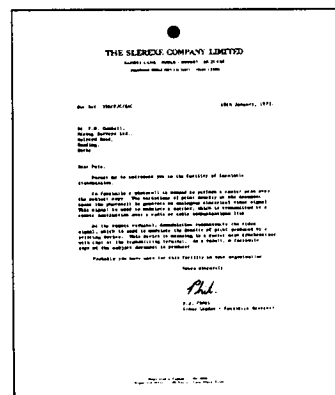

### Note:

- Any details given in these instructions are subject to change without notice.
- The picture and illustrations in these instructions may vary slightly from the actual product.

## ■ Interface pin

The signals are assigned to the interface pins of the KX-F1050/KX-F1070 as follows.

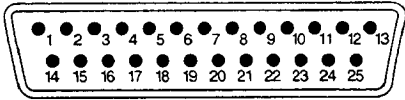

Item	Signal Name	Pin No. D-SUB 25 pin	Signal Direction	Function
Transmitted data	TD	2	DTE→DCE	Used for transmitted data.
Received data	RD	3	DTE←DCE	Used for received data.
Request to send	RTS	4	DTE→DCE	Signal for data transmission request from your PC (DTE) to the modem (DCE). Also used for flow control.
Clear to send	CTS	5	DTE←DCE	Signal for the modem to permit data transmission from your PC (DTE) to the modem (DCE). Also used for flow control.
Data set ready	DSR	6	DTE←DCE	Signal which shows the status when the modem is available for transmission and reception.
Signal GND	SG	7	DTE↔DCE	Signal ground.
Carrier detect	CD	8	DTE←DCE	Carrier detect signal.
Data terminal ready	DTR	20	DTE→DCE	Signal which shows the status when your PC is available for communication.
Ring indicator	RI	22	DTE←DCE	Sends the signal according to the request signal.
GND	FG	1	DTE↔DCE	Frame ground.



# Speed dialer list

Station No.	Name/Phone No.	Station No.	Name/Phone No.	Station No.	Name/Phone No.
00		35		70	
01		36		71	
02		37		72	
03		38		73	
04		39		74	
05		40		75	
06		41		76	
07		42		77	
08		43		78	
09		44		79	
10		45		80	
11		46		81	
12		47		82	
13		48		83	
14		49		84	
15		50		85	
16		51		86	
17		52		87	
18		53		88	
19		54		89	
20		55		90	
21		56		91	
22		57		92	
23		58		93	
24		59		94	
25		60		95	
26		61		96	
27		62		97	
28		63		98	
29		64		99	
30		65			
31		66			
32		67			
33		68			
34		69			

Station numbers 00 to 99 are available for KX-F1050, and 00 to 79 for KX-F1070.

# Speed dialer list

Station No.	Name/Phone No.	Station No.	Name/Phone No.	Station No.	Name/Phone No.
00		35		70	
01		36		71	
02		37		72	
03		38		73	
04		39		74	
05		40		75	
06		41		76	
07		42		77	
08		43		78	
09		44		79	
10		45		80	
11		46		81	
12		47		82	
13		48		83	
14		49		84	
15		50		85	
16		51		86	
17		52		87	
18		53		88	
19		54		89	
20		55		90	
21		56		91	
22		57		92	
23		58		93	
24		59		94	
25		60		95	
26		61		96	
27		62		97	
28		63		98	
29		64		99	
30		65			
31		66			
32		67			
33		68			
34		69			

Station numbers 00 to 99 are available for KX-F1050, and 00 to 79 for KX-F1070.

# Index

---

<b>A</b>	Automatic dialing .....	27, 28	<b>O</b>	One-touch dialing .....	27, 28
				Overseas transmission mode .....	34
<b>C</b>	Cleaning .....	64	<b>P</b>	Pager alert .....	39
	COPY button .....	26		PAUSE button .....	31
	Copy reduction mode .....	45		Polling .....	32
<b>D</b>	Date and time .....	14	<b>R</b>	RECEIVE MODE button .....	17
	Delayed transmission .....	33		Receiving reduction mode .....	42
	DELETE key .....	15		REDIAL/PAUSE button .....	31
	Dialing mode .....	13		Remote fax activation code .....	36
	Direct call station keys .....	15, 27, 28		Remote TAM activation ID .....	47
	DIRECTORY button .....	28, 29		RESOLUTION button .....	20
	Display contrast .....	49		Ring pattern detection .....	38
<b>E</b>	Electronic telephone directory .....	29		Ringer volume .....	16
	Error messages .....	55	<b>S</b>	SECRET key .....	27
	Extension copy .....	44		Set default .....	50
	EXT. TAM mode .....	17, 46		Silent detection .....	48
<b>F</b>	FAX mode .....	17, 25		Silent fax recognition ring .....	24
	FAX ring count .....	25		SPACE key .....	15
	Feeder pressure .....	63		Speed dialing .....	27, 28
	FILM/PAPER SAVE key .....	43		START/SET button .....	14, 21
	FLASH button .....	31		STOP button .....	21
<b>H</b>	HANDSET MUTE button .....	19	<b>T</b>	TEL mode .....	17
	Handset volume .....	16		Telephone number list .....	52
	HELP button .....	13		TEL/FAX mode .....	17, 23
<b>I</b>	INSERT key .....	15		TEL/FAX ring .....	24
<b>J</b>	Journal auto print .....	53		TONE button .....	31
	Journal report .....	52, 53, 54		Transmission report .....	52, 53, 54
	Junk mail prohibitor .....	37	<b>V</b>	Visual film indicator .....	7
<b>L</b>	Logo position .....	49		Voice contact .....	30
	LOWER key .....	27, 28		VOLUME button .....	16
<b>M</b>	MENU button .....	14, 27, 32, 52	<b>Y</b>	Your facsimile telephone number .....	16
	MONITOR .....	19, 21		Your logo .....	14
	Monitor volume .....	16			

Panasonic  
KX-F1050  
KX-F1070  
Proof of Purchase

## Panasonic FAX ADVANTAGE PROGRAM

**We are proud to present the Panasonic Fax Advantage Program. It's an incredible service program that's full of exciting advantages!**

### Customer Satisfaction

In support of our one-year limited warranty\* (parts and labor) on our current fax product line, Panasonic is proud to offer you the following service options during the limited warranty period:

- 1 If you mail-in or carry-in your fax unit to one of our Regional Servicenters, the product will be repaired and returned to you, or...
- 2 If you call our 1-800-HELPFAX toll-free number, you will receive a refurbished replacement product overnight or on the second business day (delivery depending on the time of your call.)

### Support After The Sale

If you have a problem with your fax, just call our 1-800-HELPFAX toll-free number for friendly support and assistance. We have a highly-qualified team of experts who can diagnose, and most likely solve, your problem over the phone. Approximately 90% of our customers' problems are resolved with just a simple phone call.

The Fax Advantage Program covers the first year of purchase and works like this:

- 1 If you have a problem with your fax, call toll-free 1-800-HELPFAX.
- 2 Talk to one of our experienced technical experts to diagnose (and most likely solve) your problem over the phone.
- 3 Providing that you may be entitled to Panasonic's service under the terms and conditions of the limited warranty\*\*, we will arrange for a reconditioned replacement unit to be shipped to you overnight or second business day delivery, depending on the time of your call. The replacement unit will be completely refurbished, quality-tested by Panasonic technicians, and individually hand-inspected before it is shipped to you. You will keep the replacement unit and send your original unit to us, along with a copy of your receipt.
- 4 This receipt *must be shipped back* with your original unit to Panasonic Company (as per instructions enclosed in your replacement unit's box).

Any unit that is replaced by Panasonic and *not* backed up by a proof of purchase by you will be subject to a minimum \$100.00 charge. Any unit that is replaced, but does not meet the terms and conditions of the limited warranty will be subject to additional charges, as per the program guidelines.

5 Once you receive your replacement unit, pack up your problem unit in the replacement unit's box. UPS will make 3 attempts within 10 days to pick-up your defective unit at no charge to you (should you be entitled to warranty service. If warranty conditions do not apply, you will be charged for all applicable shipping charges). *The product must be properly packaged in the same manner as the replacement unit, utilizing the packing materials provided.* You must make your unit available for UPS pick-up. If your unit is not available for UPS, you will be responsible for shipping unit back at your expense. Damage due to improper or inadequate packing will be charged back to your charge card as an out-of-warranty cost, as per the warranty stipulations.

### Requirements:

6 You must give our technicians a valid credit card number. They will charge your card account to cover any charges that are incurred by failure to send the problem product to Panasonic Company. If your problem unit is not eligible for warranty, you will be charged for the repair of the unit and for any shipping charges associated with this program. If you do not wish to pay out-of-warranty repair costs, you will be responsible for returning the replacement unit to Panasonic and for paying all shipping charges associated with this program including the overnight delivery of replacement product to you, shipment of problem unit to Panasonic, the replacement unit back to Panasonic and the return of your original unit back to you.

#### Acceptable credit cards:

Discover VISA  
Master Card American Express (Optima)

Product that is not returned to Panasonic by 10 business days after shipment of the replacement product, will be charged to your account at Panasonic's Suggested Retail Price (see dealer for details).

Credit status will be verified prior to sending the replacement product.

Proof of Purchase must be included with the returned unit to verify warranty status.

Any parts and labor that are not covered by the limited warranty\* will be charged as a non-warranty repair and billed at Panasonic's current rate for parts and labor.

\*See the warranty stipulations in these instructions.

\*\*Replacement program excludes Puerto Rico and is subject to termination at any time without advance notice.



**Matsushita Consumer Electronics Company, Division of Matsushita Electric Corporation of America**  
One Panasonic Way, Secaucus,  
New Jersey 07094

**Panasonic Sales Company, Division of Matsushita Electric of Puerto Rico, Inc. ("PSC")**  
Ave. 65 de Infantería, Km. 9.5  
San Gabriel Industrial Park, Carolina,  
Puerto Rico 00985