

MAGNAVOX
Smart. Very smart.®

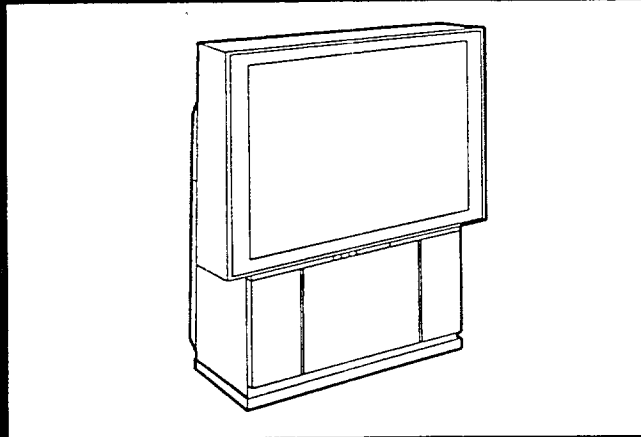

OWNER'S MANUAL

QUESTIONS ABOUT THIS PRODUCT?
CALL OUR INFORMATION CENTER.

800-531-0039

IMPORTANT

Return Your
Warranty Registration Card
Within 10 Days.
See Why Inside.

MAGNAVOX
Smart.Very smart.
**WARRANTY
REGISTRATION
CARD**

Return your Warranty Registration Card today to ensure you receive all the benefits you're entitled to.

Once your MAGNAVOX purchase is registered, you're eligible to receive all the privileges of owning a MAGNAVOX product. So complete and return the Warranty Registration Card enclosed with your purchase at once. And take advantage of these important benefits.

■ Warranty Verification

Registering your product within 10 days confirms your right to maximum protection under the terms and conditions of your MAGNAVOX warranty.

■ Owner Confirmation

Your completed Warranty Registration Card serves as verification of ownership in the event of product theft or loss.

■ Model Registration

Returning your Warranty Registration Card right away guarantees you'll receive all the information and special offers which you qualify for as the owner of your model.

MAGNAVOX
Smart.Very smart.

**Congratulations on your purchase
—and welcome to the "family!"**

Dear MAGNAVOX product owner:

Thank you for your confidence in MAGNAVOX. You've selected one of the best-built, best-backed products available today. And we'll do everything in our power to keep you happy with your purchase for many years to come.

As a member of the MAGNAVOX "family," you're entitled to protection by one of the most comprehensive warranties and outstanding service networks in the industry.

What's more, your purchase guarantees you'll receive all the information and special offers which you qualify for, plus easy access to accessories from our convenient home shopping network.

And most important of all, you can count on our uncompromising commitment to your total satisfaction.

All of this is our way of saying welcome—and thanks for investing in a MAGNAVOX product.

Sincerely,



Robert Minkhorst
President and Chief Executive Officer

P.S. Remember, to get the most from your MAGNAVOX product, you must return your Warranty Registration Card within 10 days. So please mail it to us right now!

HURRY!
Registration
Needed
Within 10
Days.

KNOW THESE SAFETY SYMBOLS.

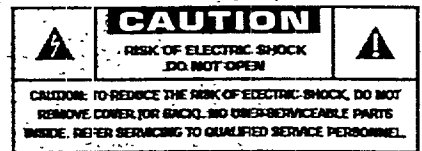

▲ This "bolt of lightning" indicates uninsulated material within your unit may cause an electrical shock. For the safety of everyone in your household, please do not remove product covering.

▲ The "exclamation point" calls attention to features for which you should read the enclosed literature closely to prevent operating and maintenance problems.

WARNING: TO PREVENT FIRE OR SHOCK HAZARD, DO NOT EXPOSE THIS EQUIPMENT TO RAIN OR MOISTURE.

CAUTION: To prevent electric shock, match wide blade of plug to wide slot, and fully insert.

ATTENTION: Pour éviter les chocs électriques, introduire la lame la plus large de la fiche dans la borne correspondante de la prise et pousser jusqu'au fond.

For Customer Use:

Enter below the Serial No. which is located on the rear of the cabinet. Retain this information for future reference.

Model No. _____

Serial No. _____



Getting Started

Warning/Precautions	2-3
Features and Model Information	4
How to Follow your Easy-to-Use Owner's Guide	5
Antenna and Cable TV Connections	6-7
VCR to TV Antenna Connections	7
First Time Set-Up and Use of the TV	8-11
Basic TV and Remote Control Operation	12-13



On-Screen Features

How to Use the On-Screen Feature Controls	14-15
How to Select Picture and Sound Controls	16
◇ Selecting a Picture Source	16
◇ Adjusting Brightness, Picture, Color, Tint, and Sharpness Controls	17
◇ Using the Clearview Control	18
◇ Using the Flesh Correction Control	19
◇ Adjusting Bass, Treble, and Balance Sound Controls	20
◇ Using the Expander Sound Control	20
◇ Setting the TV for Stereo Programs	21
How to Select Advanced Controls	22
◇ Setting the TV Clock	22
◇ Setting the TV for Closed Captioning	23
◇ Using the Sleep Timer Control	24
◇ Using the Time/Channel Reminder Controls	25
◇ Adjusting the Size of Channel/Time Display	26
◇ Setting the TV for Cable or Antenna Signals	27
◇ Adding Channels in Memory (Automatically)	28
◇ Adding Channels in Memory (Manually)	29
◇ Adjusting the TV's Convergence Control	30
◇ Using the TV Speaker On/Off Switch with the Audio Output jacks	31
◇ How to Censor the Viewing of Channels	32-33
◇ Using the TV's Audio/Video Input and Output Jacks	34-36
◇ Surround Sound Speaker Connections	37



Remote Control Operation

Using the Remote (TV/VCR buttons)	38-39
Using Smart Sound or Auto-Volume	40
Using the Channel Guide Control	41
Setting the Personal Preference Control	42-43
Setting the Remote to Work Your VCR	44-45
Setting the Remote to Work Your Cable Converter	46-47
Setting the Remote to Work a VCR or Cable Converter - "Search Method"	48-49



Picture-In-Picture (PIP)

How to Use PIP (Connections)	50-51
How to Use PIP with the TV Remote	52-53
Selecting the Picture Source for PIP	54
Adjusting Picture-in-Picture Color and Tint	55
More PIP Connections (Cable Converter)	56



General Information

Tips if Something Isn't Working	57
Glossary of TV Terms	58
Index	59
RF Switcher Information	59
Warranty	60

The Model and Serial Numbers are found on the back of this TV set. Please record these numbers and purchase date in the space below. Refer to them whenever you ask your dealer about this TV set.

Model No. _____

Serial No. _____

Purchase Date _____

Please attach your sales receipt to this book and keep it for future reference.

**QUESTIONS ABOUT THIS PRODUCT?
CALL OUR INFORMATION CENTER.**

800-531-0039

**WARNING: TO PREVENT FIRE OR SHOCK
HAZARD DO NOT
EXPOSE THIS UNIT TO RAIN OR EXCESSIVE
MOISTURE.**



First Time Set Up which automatically sets the TV for local channels and antenna mode. It even helps you make the necessary connections for the Picture-In-Picture (PIP) feature (see page 8.)

Infrared Remote Control which operates your TV set and a variety of wireless remote control VCRs and Cable TV Converters.

Standard TV broadcast (VHF/UHF) or Cable TV (CATV) channel capability.

Closed Captioning which allows the viewer to read TV program dialogue or voice conversations as on-screen text.

Automatic Programming of channels for quick and easy selection of favorite stations available in your area.

Picture-In-Picture (PIP) which can show a TV program and the direct video output from an accessory (VCR, etc.) onto the TV screen at the same time.

Parental Control for "Censoring" or blanking out channels and Audio/Video Input jack connections to prevent children from watching undesirable programming.

Stereo-Ready TV with built-in audio amplifier and twin speaker system. Receives TV programs in both broadcast stereo sound or (SAP) bilingual broadcast.

On-Screen Features which display helpful information for setting of TV controls (such as color adjustment, timer settings and channel programming).

Audio/Video jacks for direct connections with VCRs (and other accessories) for quality TV picture and sound playback.

Surround Sound external audio speaker connections.

Sleep-Timer which automatically turns the TV OFF at preset time intervals.

As you unpack your TV please note that the following items have been included with your set:

- Owner's Manual
- Warranty Registration Card
- Safety Tip Information Brochure
- Factory Service Address Directory
- Remote Control Transmitter
- Batteries for Remote Control Use
- Accessory Products Information Brochure
- Audio/Video Cables for Direct Input and Output Connections.

Please take a few minutes to complete your registration card. The serial number for the TV is on the back of the set.

Please keep your packing material for any future use.

To ensure that picture screen performance is of the highest quality, please avoid rubbing any object or material on the screen that could scratch or damage its surface.

Refer to the back of this manual for instructions on the cleaning and care of the TV.



The style and design of this Owner's Guide comes from you the customer. We've asked owners, such as yourself, just what it is they would like to see to make our instructions more helpful and easier-to-follow. See below for the results of some of the simple and easy-to-use suggestions that you have given us.

Feature explanations are kept clear, simple and in easy to understand terms. If you do run into a word that's too technical, see the glossary in the back of the book.

BEGIN signs are given to always let you know where and how to start a task or operation.

I Diamond shaped numbers tell you step-by-step how you're to do a task.

STOP signs are shown to tell you when you're through or finished with a task.

Try it out steps are given to let you know if you've completed a task and have done it right.

Large pictures always appear alongside the numbered steps. The same diamond shaped step numbers are repeated in the picture to show you what button to press, what you're supposed to see on the TV, or how best to complete an operation.

Reminder notes are used to fill you in on more operating details for the feature. They can also show you things to check on if you're having difficulty making the feature work.

First let's connect your Antenna or Cable TV signal to your TV. This will be easy since there is only one antenna plug (75Ω) on the back of your TV - and that's where the antenna goes.

BEGIN

1 If your antenna (or CABLE TV signal) has a round cable (75 ohm) with a metal prong (F-connector) on the end, then you're ready to connect it to the TV.



If your antenna has flat twin-lead wire (300ohm), you first need to attach the antenna wires to the screws on an optional (300 to 75 ohm) adapter.

2 Push the round end of the cable (or adapter) onto the ANTENNA plug on the back of the TV. If the round end of the cable connector is threaded, screw it down tight.



Try it out. Press **POWER** to turn the TV ON. Press the **CHANNEL UP** button. You should see local channels flash by.

Remember. Use the **FIRST TIME SETUP** section (page 8) to have the TV automatically set itself for local channels and type of antenna signal.

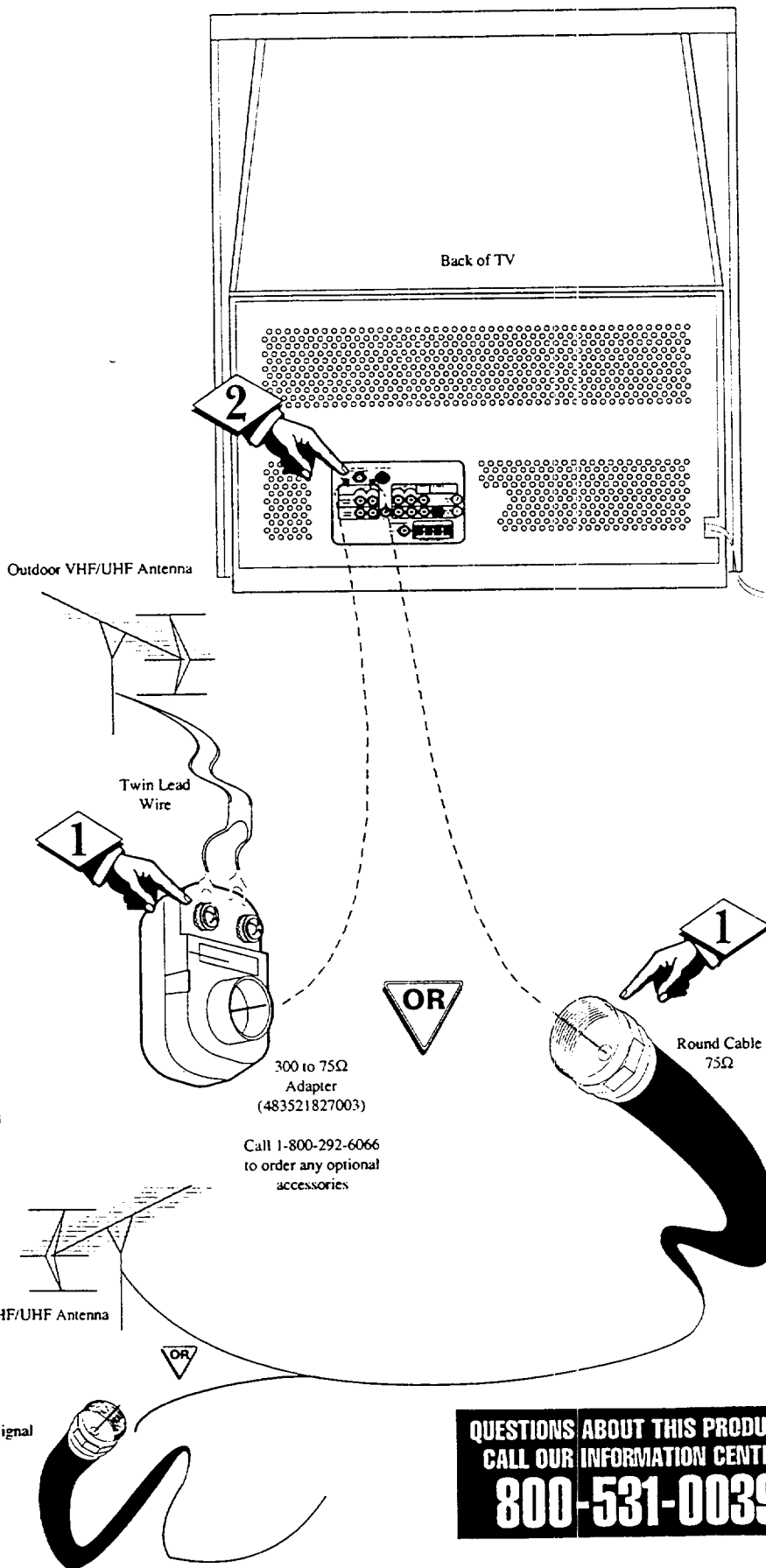

Call 1-800-292-6066 to order any optional accessories

**QUESTIONS ABOUT THIS PRODUCT?
CALL OUR INFORMATION CENTER.
800-531-0039**



Some of you may have two separate antennas. For instance, one antenna is for VHF channels (2-13), and the other antenna is for UHF channels (14-69)

BEGIN

For homes with two separate antennas, you will need an optional "combiner" before you can connect to the TV. See ordering details below.

1 Attach the separate antennas to the correct screws on the combiner.

2 Push the round end of the combiner onto the ANTENNA plug on the rear of the TV.

STOP

To order any optional accessory contact your dealer or call the toll-free accessory ordering number (1-800-292-6066):

- UHF/VHF CombinerSBV1133A01
- 75-300 Ohm AdapterSBV1113A01
- 300-75 Ohm Adapter483521827003

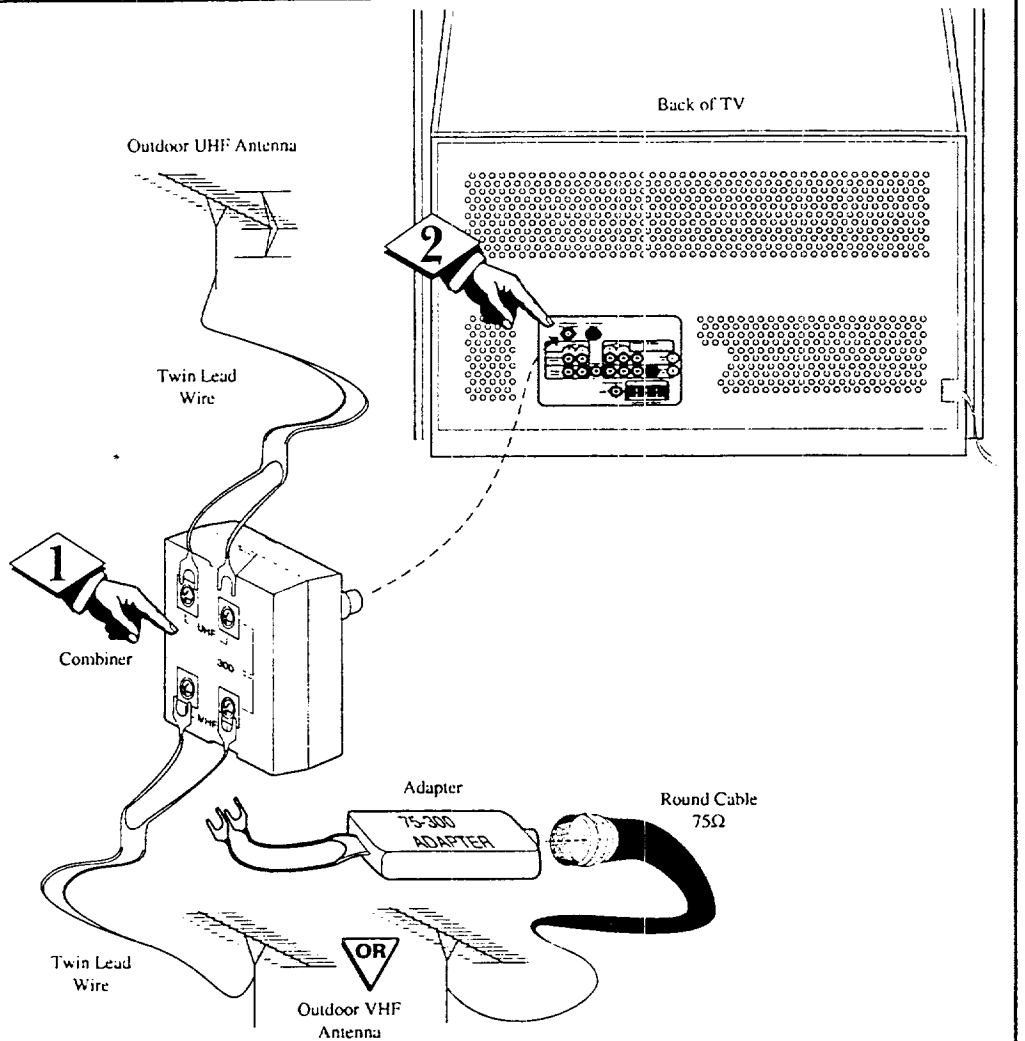

VCR TO TV ANTENNA CONNECTION

To connect a VCR to the TV:

BEGIN

1 Connect your Antenna or Cable TV signal to the IN FROM ANT plug on the back of the VCR.

2 Connect the OUT TO TV plug on the VCR to the Antenna plug on the TV. (Connecting cable supplied with the VCR).

STOP

Remember. To use the Picture-In-Picture (PIP) feature with a VCR more connections will be needed. See pages 10 and 50 for details on how to connect and work with PIP.

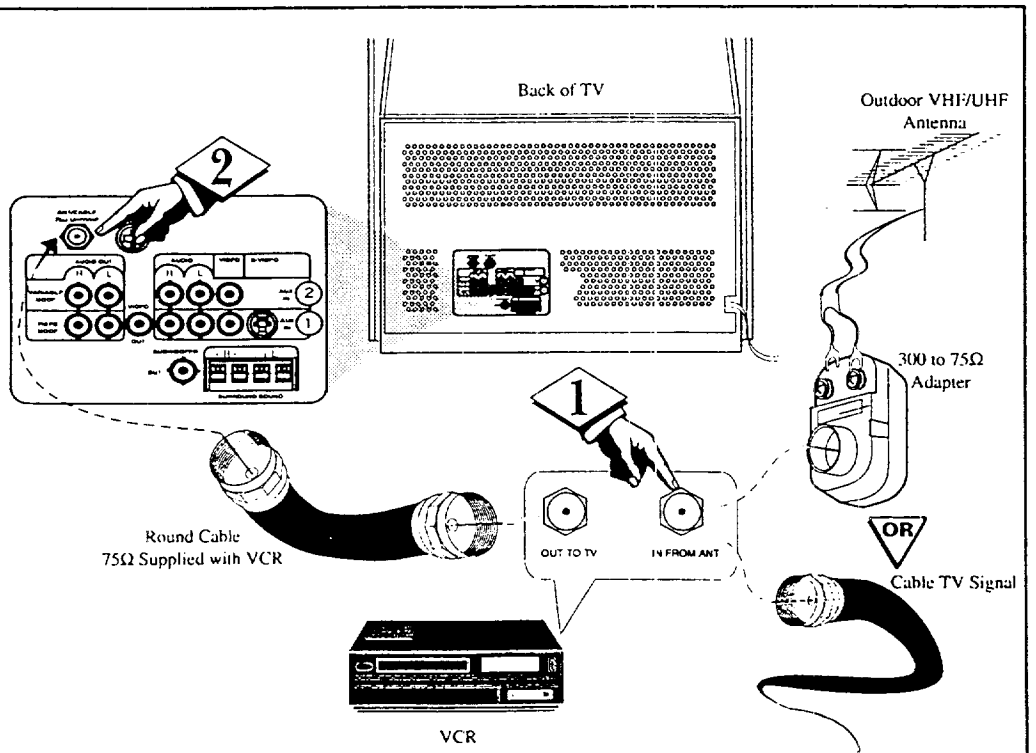

First Time Set Up makes the initial use of your TV easy and automatic. Just follow the steps below and let your TV set itself for local channels and the type of antenna signal you have. You can also set the TV's clock and make connections for the Picture-In-Picture feature with First Time Set Up.

BEGIN

1 Press the **MENU** button on the TV or the remote control.

A TELEVISION ADJUSTMENTS screen appears on the TV. (For more details on "How to Use On-Screen Features" see page 14).

2 Press the **MENU** ∇ button to move the on-screen arrow to **FIRST TIME SETUP**.

3 Press the **MENU** button to select **FIRST TIME SETUP**.

4 Press **MENU** button again to continue with **FIRST TIME SETUP**.

5 Check that your **Antenna** (or **Cable TV**) signal is connected to the rear of the TV. (See page 6 if you need any help).

6 Press **MENU** button to continue.

The TV will begin to automatically set itself:

- First for the type of signal you connected - either Antenna or Cable.
- Then for the TV channels available in your area.

Remember. You may press the **STATUS** button (on the TV or remote) to stop the **FIRST TIME SETUP** at any time.

continue to the next page....

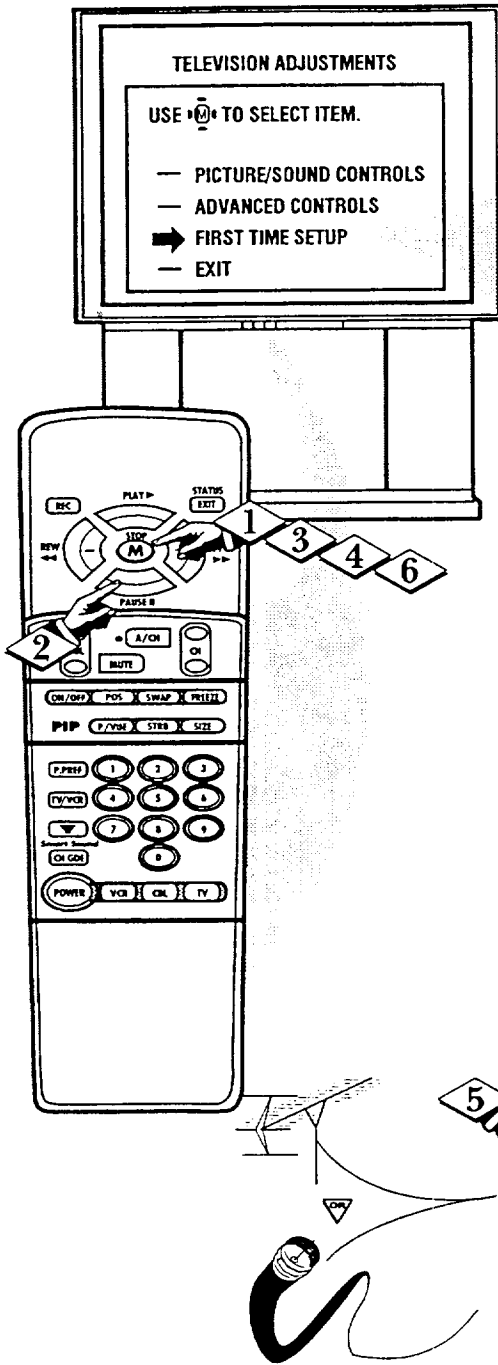

THE FIRST TIME SETUP PROVIDES A SIMPLE METHOD OF ADJUSTING THE MOST IMPORTANT CONTROLS FOR THIS TELEVISION RECEIVER.

PRESS [M] TO CONTINUE

MANY OF THE CURRENT TV CONTROL SETTINGS WILL BE MODIFIED BY CONTINUING WITH FIRST TIME SETUP.

PRESS [STATUS] TO QUIT OR PRESS [M] TO CONTINUE

PLEASE CHECK THAT YOUR ANTENNA OR CABLE IS CONNECTED TO THE PLUG MARKED ANT/CABLE ON THE TV REAR INPUT PANEL.

PRESS [STATUS] TO QUIT OR PRESS [M] TO CONTINUE

* PLEASE WAIT *

SYSTEM IS TESTING FOR CORRECT TUNING MODE.



The Testing and Searching for channels by the TV will last only a few minutes. The TV will even tell you when it is finished and how many channels it has saved.

"SAVED IN MEMORY" channels are the ones you select when you press the CHANNEL▲▼ buttons.

7 Press the MENU button to continue to set the TV clock.

8 Press the MENU ▲▼ buttons to set the time on the TV clock.

Press the MENU (+) or (-) buttons to move between the hours and minutes parts of the clock.

9 Press the MENU button to continue to make connections with a VCR for the Picture-In-Picture (PIP) feature.

 Remember. You will need the VIDEO (yellow) and AUDIO (red/white) cables supplied with your TV to complete the PIP connections with a VCR.

continue to the next page....

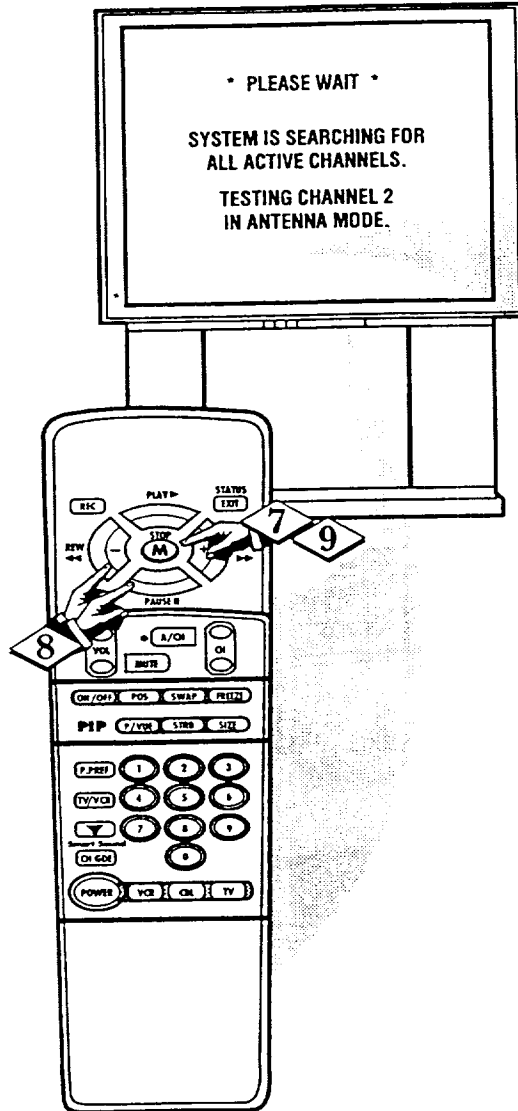

THE SEARCH FOR ACTIVE CHANNELS IS COMPLETE.
17 CHANNELS WERE FOUND AND SAVED IN MEMORY.
PRESS [M] TO CONTINUE

PLEASE CHECK TV CLOCK AND ADJUST IF NECESSARY.
THE TIME IS CURRENTLY SET TO 12:00
USE [L/R] TO ADJUST TIME THEN PRESS [M] TO CONTINUE

THIS TV IS EQUIPPED WITH PICTURE-IN-PICTURE (PIP)
PROPER PIP OPERATION REQUIRES THAT A VCR MUST BE CONNECTED TO THE TV'S VCR/AUX 1 INPUTS USING THE METHOD THAT FOLLOWS
PRESS [M] TO CONTINUE

10 Connect the VIDEO OUT plug on the VCR to the AUX IN1 VIDEO IN plug (yellow) on the TV (see picture.)

The TV will show you when the "CABLE HAS BEEN CONNECTED" to the right plug.

Press MENU button to go on with PIP connections.

11 Connect the AUDIO OUT plugs (Right and Left) on the VCR to the AUX IN1 AUDIO IN (red/white) plugs on the TV.

Again the TV will show you when the "CABLE HAS BEEN CONNECTED" to the right plugs.

Press MENU button to go on.

12 Turn the VCR ON and PLAY a recorded tape.

13 Press MENU button to see PIP. The playback of the VCR tape should show up in the PIP WINDOW.

If the VCR playback doesn't show up in the PIP Window, go back and check your cable connections on the TV and VCR.

14 Press MENU button if you want to find out about the TV's Surround Sound feature.

continue to the next page....

Remember. If you have a single (monaural) Audio Output VCR, "Y" connectors are available to complete your connection. Contact your dealer, or our Parts Information Center, for details.

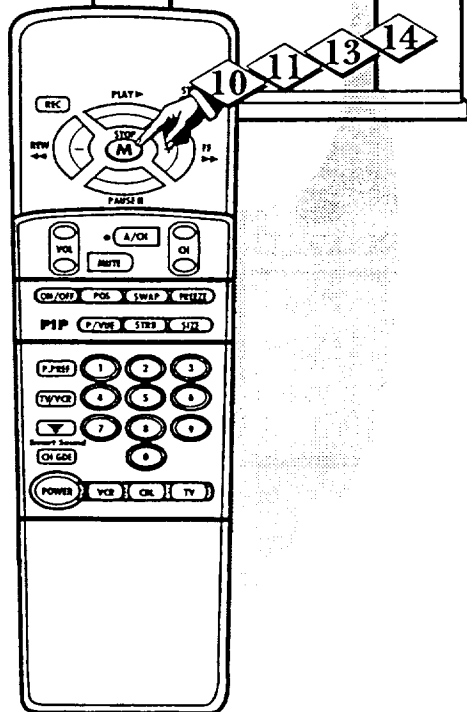
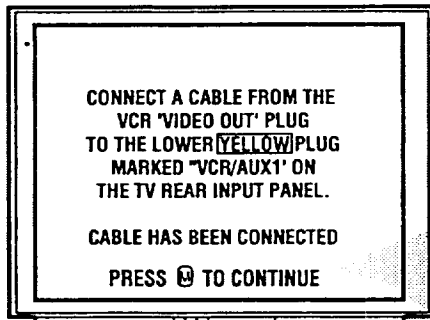
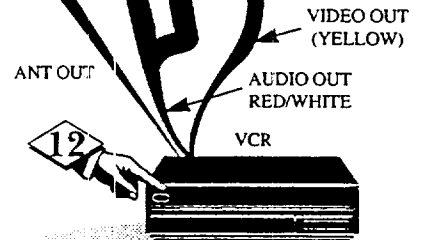
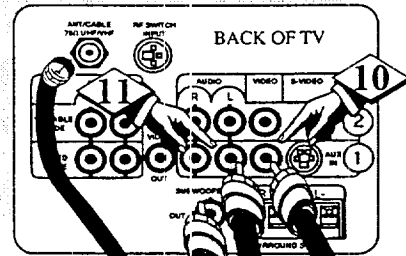

CONNECT THE AUDIO CABLES FROM THE VCR 'AUDIO OUT' PLUGS TO THE LOWER RED AND WHITE PLUGS MARKED 'VCR/AUX1' ON THE TV REAR INPUT PANEL.

CABLE HAS BEEN CONNECTED
PRESS [MENU] TO CONTINUE

PLEASE TURN ON THE VCR, INSERT A RECORDED TAPE, THEN PRESS THE 'PLAY' BUTTON ON THE VCR.

NOW PRESS [MENU] TO VIEW PIP

PIP WINDOW →

IF YOU DO NOT SEE THE VCR PICTURE IN THE PIP WINDOW PLEASE CHECK AGAIN THAT ALL CABLES ARE PROPERLY CONNECTED.

PRESS [MENU] TO CONTINUE



15 The TV first tells you that for Surround Sound to work with the set you will need an additional pair of external speakers (8 ohm, 15 watt minimum).

Press the MENU button to go on.

16 Then the TV asks you to read the Surround Sound section in the Owner's Guide (page 37) after you're finished with First Time Set Up.

Press the MENU button to go on.

17 Press the MENU button again to complete the FIRST TIME SETUP and return to normal TV viewing.

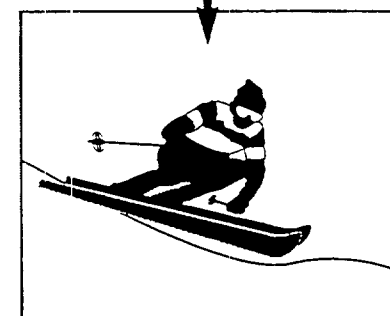
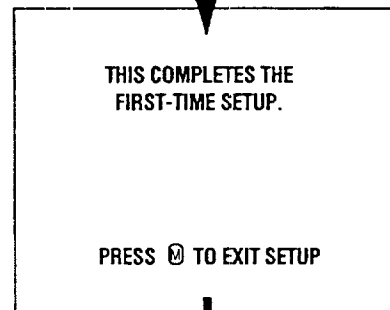
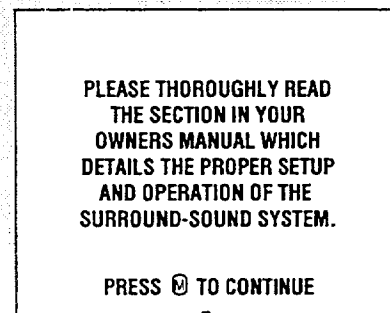
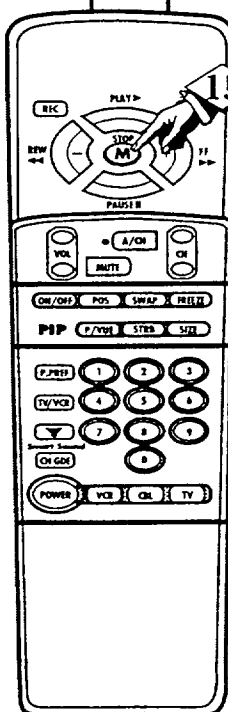
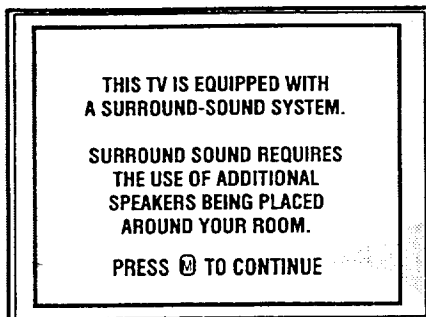

BEGIN

1 Press the **POWER** button to turn the TV ON. (Note: you can press any button on the front of the TV to turn the TV ON).

The tuned channel number will appear briefly when the TV is first turned ON. You can also press the **STATUS** button to see what channel the TV is ON.

2 Press the **VOLUME UP** (▲) or **DOWN** (▼) button to adjust the sound level.

3 Press the **CHANNEL UP** (▲) or **DOWN** (▼) button to select TV channels.

See **FIRST TIME SETUP** (page 8) on how the TV can set itself to select your local channels.

4 Press the TV "System" button on the remote to be sure the remote sends its commands to the TV.

Point the remote control at the remote sensor window on the TV when operating the TV with the remote.

5 Always press two number buttons on the remote when selecting channels. For example: press "0" then "6" for channel "6".



Remember. Certain channel numbers have been added to the TV's memory at the factory. **FIRST TIME SET UP** (page 8) will automatically set the TV for your local channels and the type of antenna signal you have.

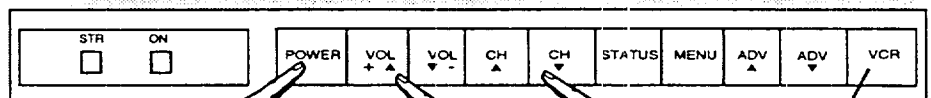
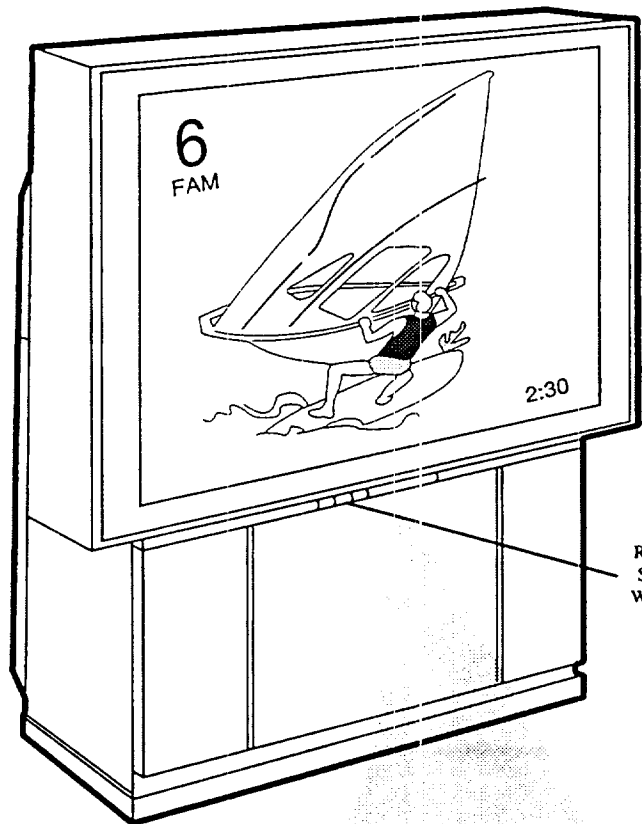

The VCR button is used for Audio/Video accessory connections made at the rear of the TV. See page 34 for details.



To load the supplied batteries into the remote:

BEGIN

- 1 Remove the battery compartment lid on the back of the remote.
- 2 Place the supplied batteries (3-AA) in the remote. Be sure the (+) and (-) ends of the batteries line up correctly (inside of case is marked.)
- 3 Reattach the battery lid.

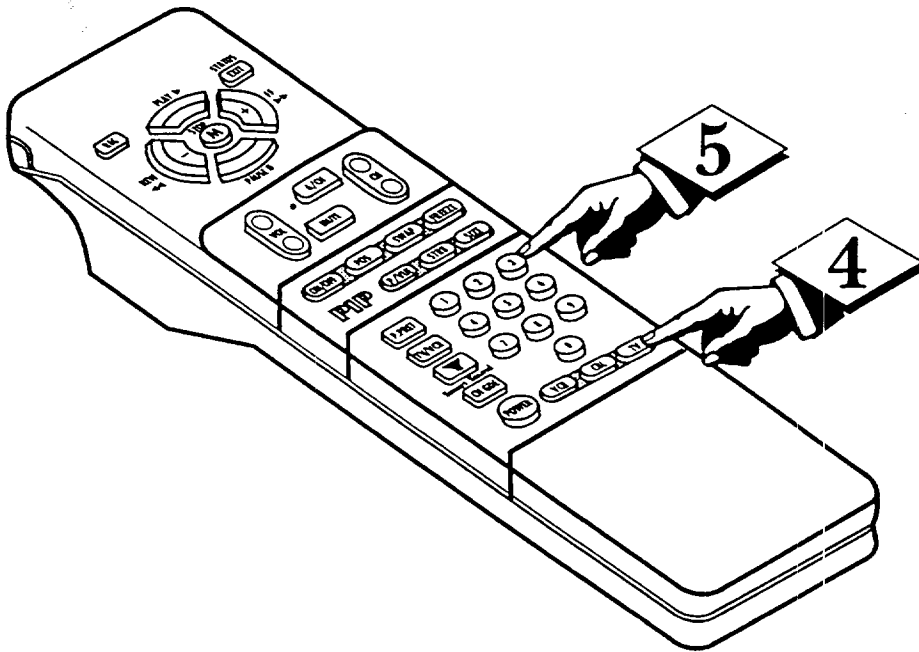
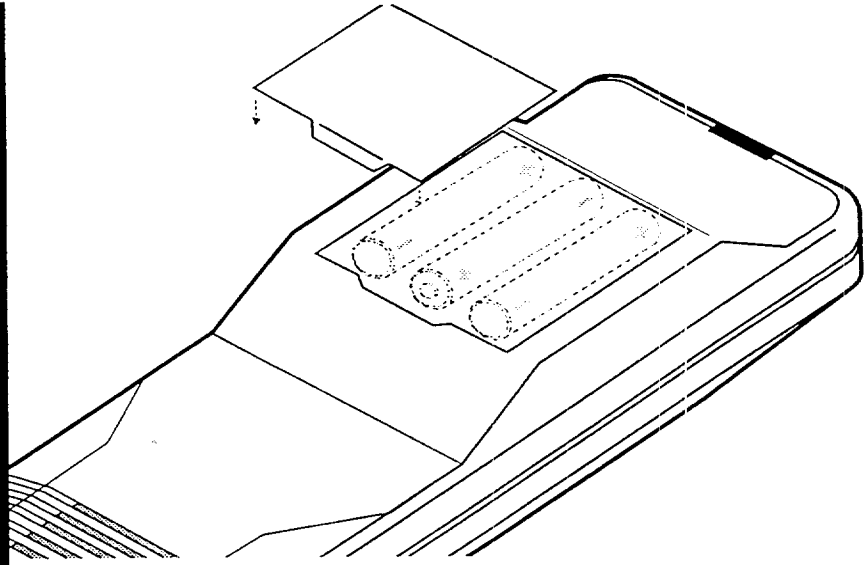

Features for your TV can be adjusted from a MENU screen shown on the TV. A MENU is nothing more than an on-screen list of features. Each MENU item can be adjusted by viewing the screen and pressing a button.

BEGIN

- 1 Press the MENU button on the remote or TV. A list of TV ADJUSTMENT controls appears on the TV screen.
- 2 Press the MENU ▲▼ buttons (on the remote) to move the RED ARROW to the desired TV Adjustments section. (See next page for list of controls).

OR

The ADVANCE (ADV) ▲▼ buttons on the TV can also be used to move the RED ARROW to the desired control.

- 3 Press the MENU button to select the Adjustment control section highlighted with the RED ARROW. A list of individual Adjustment controls appears on the TV screen.
- 4 Press the MENU ▲▼ (or ADV) buttons to move the RED ARROW up or down the list of controls. Then press MENU to select the desired control.

- 5 Press (+) or (-) buttons to adjust the selected on-screen control.

- 6 Press the STATUS button to clear the screen after an adjustment. Use the EXIT control within the MENU to return to normal TV viewing.

STOP

Remember. If an on-screen control disappears from the TV screen and you are not finished working with it, just repress the MENU button until the last selected control shows on the screen.

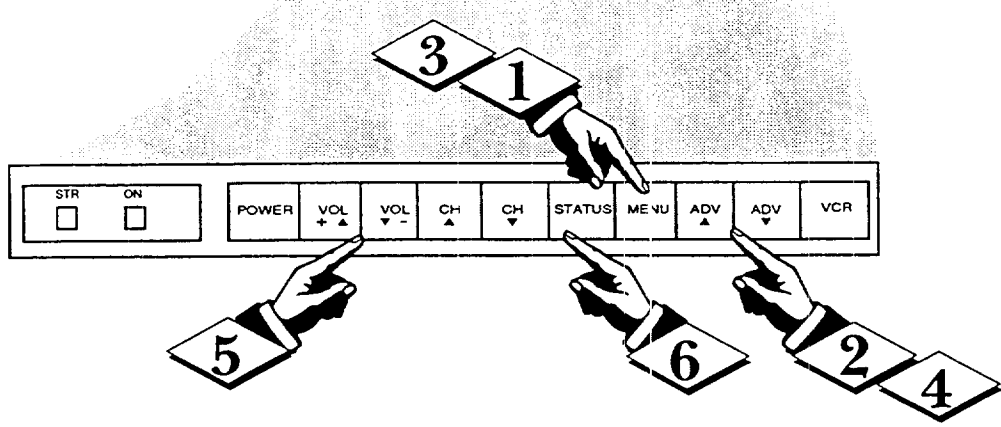
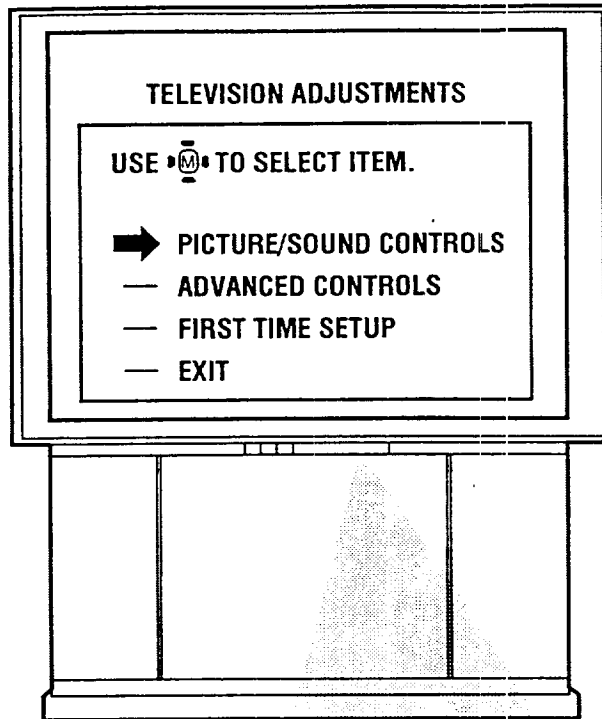

ON THE TELEVISION **OR** ON THE REMOTE

TELEVISION ADJUSTMENTS

USE  TO SELECT ITEM.

-  PICTURE/SOUND CONTROLS
- ADVANCED CONTROLS
- FIRST TIME SETUP
- EXIT

- Press MENU to view Adjustment Controls.
- Press MENU ▲▼ to move Red Arrow to desired controls list.
- Press MENU to select highlighted controls list.

PICTURE / SOUND CONTROLS

- EXIT
- PICTURE SOURCE SELECT
- BRIGHTNESS
- PICTURE
-  COLOR
- TINT
- SHARPNESS

USE  THEN  TO SELECT.

- Press MENU ▲▼ to move up and down list of control items.
- Press MENU to select highlighted control.

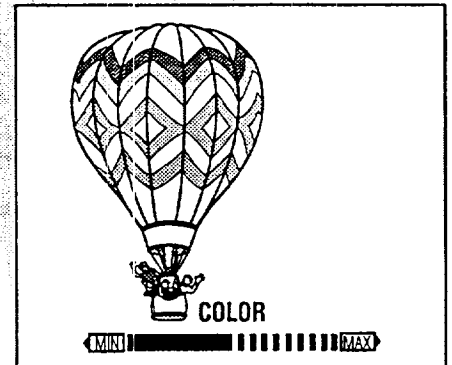

- Press (+) OR (-) buttons to adjust the selected control.

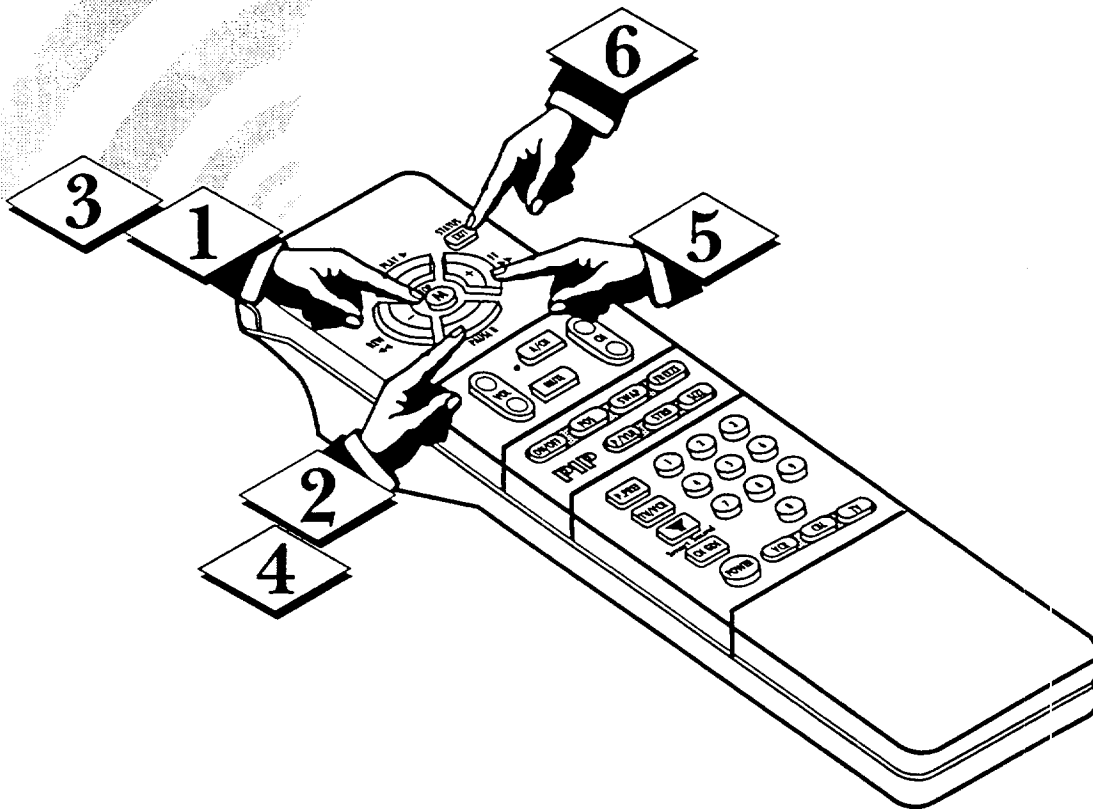

PICTURE/SOUND CONTROL ADJUSTMENTS

TO SELECT PICTURE/SOUND CONTROLS

CONTROLS

BEGIN

- 1 Press MENU button to see TV ADJUSTMENTS screen.
- 2 Press MENU ▲ or ▼ button to move RED ARROW to PICTURE/SOUND controls.
- 3 Press MENU button to select the list of PICTURE/SOUND controls.



Remember, the control with the RED ARROW is ready to be used. Just press the MENU button to select it.

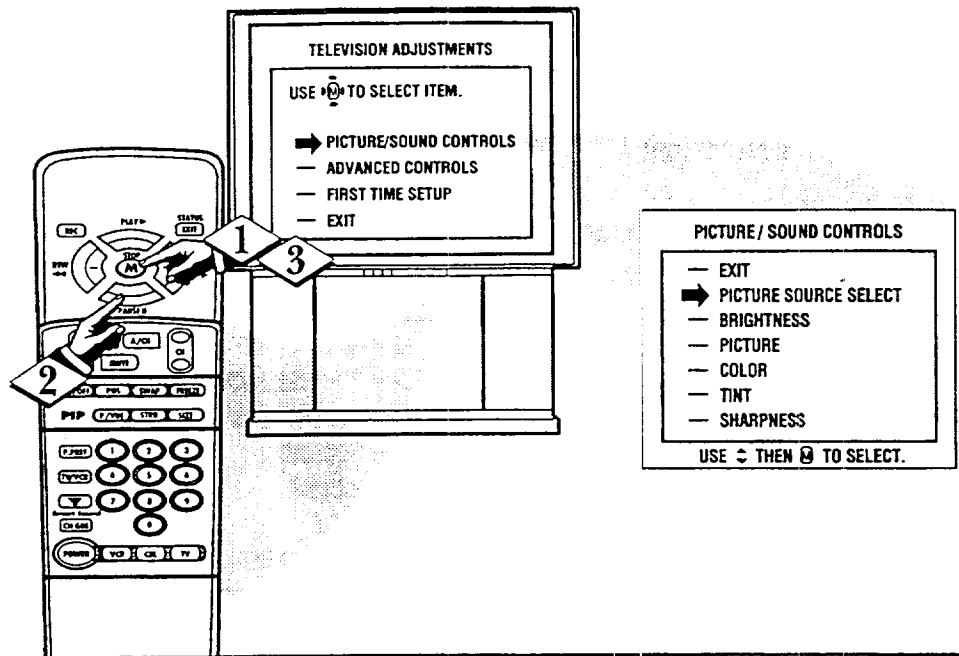

PICTURE SOURCE SELECT

The picture for the TV can come through either the ANTENNA plug or the AUDIO/VIDEO Input jacks (on the rear of the TV). The Picture Source control simply tells the TV which one of these picture sources it is to show on the TV screen.

BEGIN

- 1 Select PICTURE SOURCE SELECT control.
- With the PICTURE/SOUND CONTROLS on screen, move the red arrow with the MENU ▲▼ buttons. Then press MENU button.
- 2 Press the MENU ▲▼ buttons to place the TV in either:
 - ANT/CABLE- for a picture signal coming from the ANTENNA plug on the TV.
 - VCR/AUX1- for a picture signal coming from the AUX IN1 Audio/Video jacks on the TV.
 - AUX2- for a picture signal coming from the AUX IN2 Audio/Video jacks on the TV.
 - 3 Press the STATUS button to clear the screen.

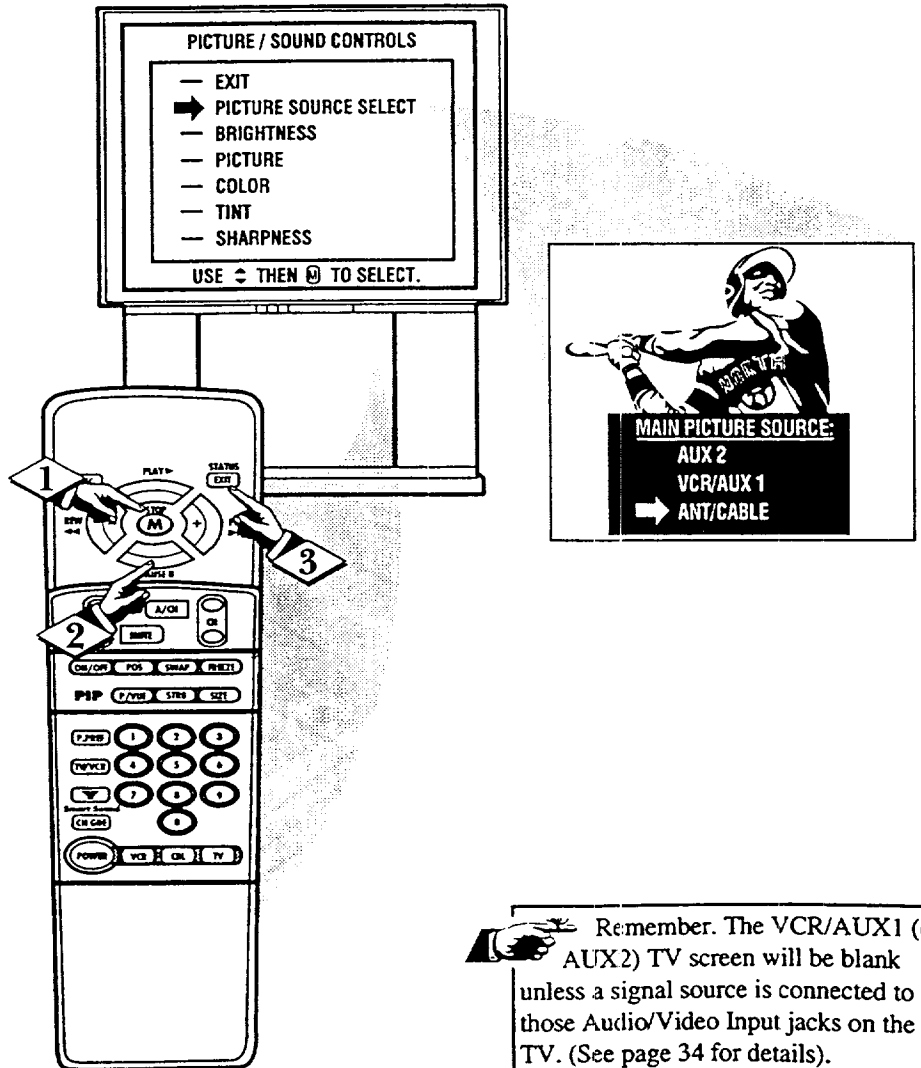

Remember. The VCR/AUX1 (or AUX2) TV screen will be blank unless a signal source is connected to those Audio/Video Input jacks on the TV. (See page 34 for details).

BRIGHTNESS PICTURE COLOR TINT SHARPNESS

To adjust your TV color and picture controls, select a TV channel and follow the steps shown below:

BEGIN

- 1 Select **BRIGHTNESS**, **PICTURE**, **COLOR**, **TINT**, or **SHARPNESS** picture control.

With the **PICTURE/SOUND CONTROLS** on screen, move the red arrow with the **MENU ▲▼** buttons. Then press **MENU** button.

- 2 Press the **(+)** or **(-)** buttons to adjust the selected control.

- 3 Press the **STATUS** button to clear the screen.



Remember. When the bar scale is centered, control settings are at normal mid-range levels.

BRIGHTNESS Press **(-)** or **(+)** until whitest parts of the picture are as bright as you prefer.

PICTURE Press **(-)** or **(+)** until dark parts of the picture show good detail.

COLOR Press **(-)** or **(+)** to add or eliminate color.

TINT Press **(-)** or **(+)** to obtain natural skin tones. (Also see **Flesh Correction** on page 14 for more information).

SHARPNESS Press **(-)** or **(+)** to improve detail in the picture.

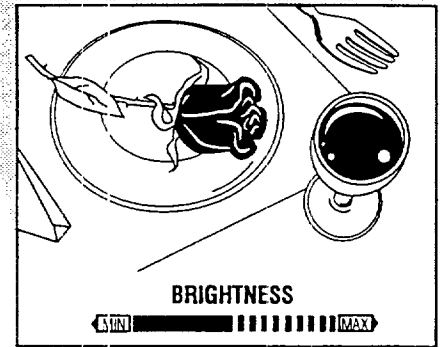
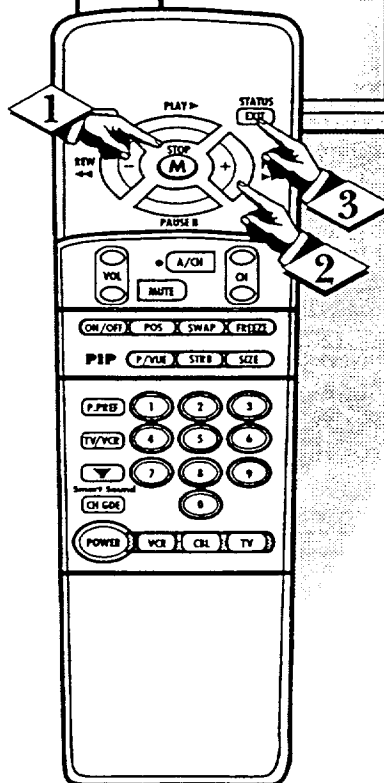
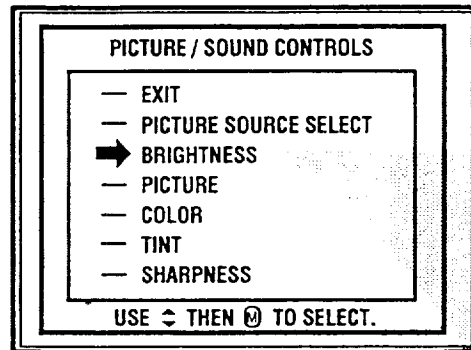

CLEARVIEW

Clearview is a sharpness feature which smoothes out background snow (or picture noise) without losing picture image detail or crispness.

BEGIN

- 1 Select CLEARVIEW control.
- 2 Press the MENU ▲▼ buttons to place the TV in ENHANCED mode.
- 3 Press the STATUS button to clear the screen.

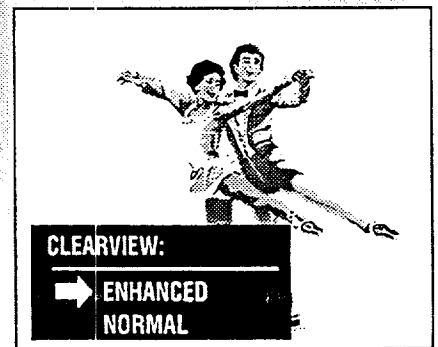
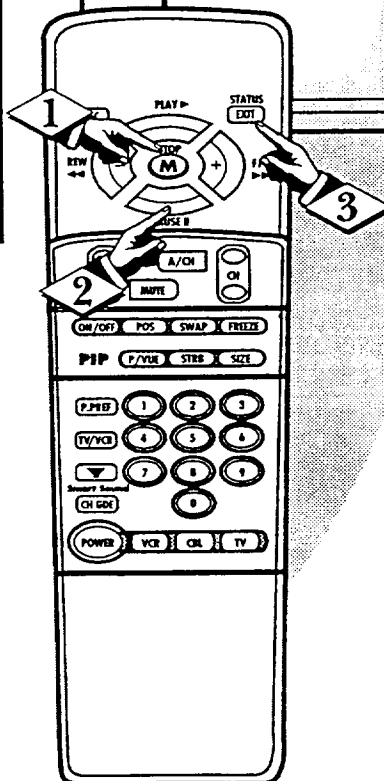
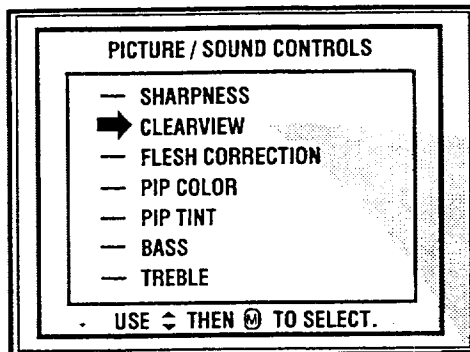

FLESH CORRECTION

Use the *Flesh Correction* control to keep skin tone hues (or facial tint) from varying from TV channel to TV channel.

BEGIN

- 1 Select **FLESH CORRECTION** control.

With the **PICTURE/SOUND CONTROLS** on screen, move the red arrow with the **MENU ▲▼** buttons. Then press **MENU** button.

- 2 Press the **MENU ▲▼** buttons to turn the **FLESH CORRECTION** control ON.

- 3 Press the **STATUS** button to clear the screen.

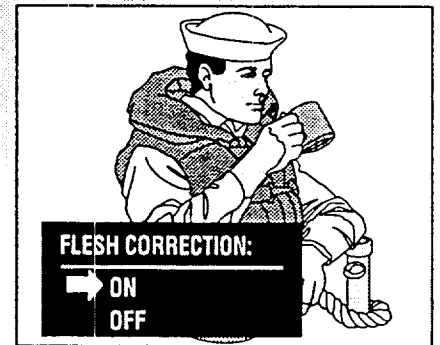
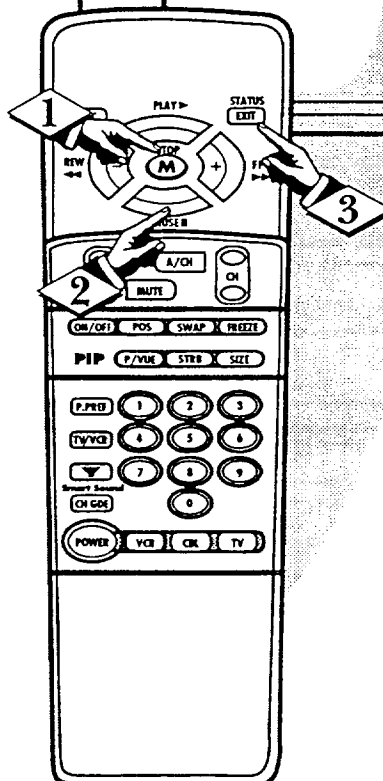
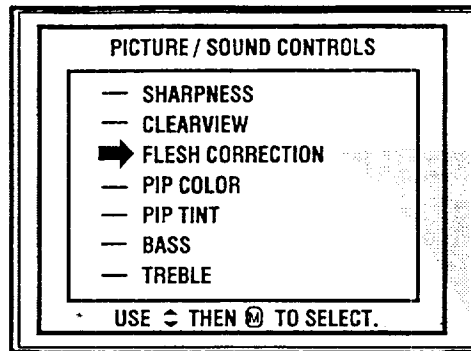

BASS, TREBLE, BALANCE

Your TV also has individual sound adjustment controls. The **BASS** (low frequency), **TREBLE** (high frequency), and **Speaker BALANCE** may all be used to adjust the sound playback of TV programs.

BEGIN

- 1 Select **BASS**, or **TREBLE**, or **BALANCE** sound control.

With the **PICTURE/SOUND CONTROLS** on screen, move the red arrow with the **MENU ▲▼** buttons. Then press **MENU** button.

- 2 Press the **(+)** or **(-)** buttons to adjust the sound control to levels you prefer.

- 3 Press the **STATUS** button to clear the screen.

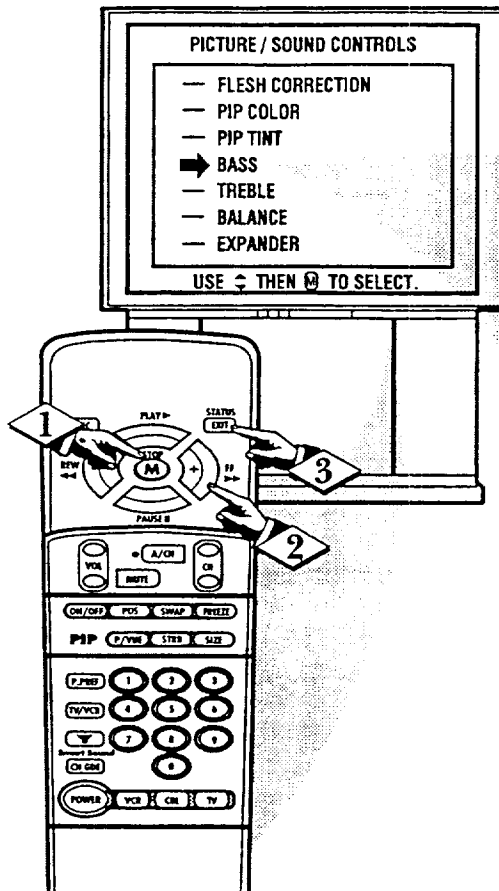

EXPANDER

EXPANDED sound can be used to add greater depth and dimension to both **monaural (MONO)** and **STEREO** TV sound.

BEGIN

- 1 Select **EXPANDER** sound control.

With the **PICTURE/SOUND CONTROLS** on screen, press the **MENU ▲▼** buttons to move the red arrow. Then press **MENU** button.

- 2 Press the **MENU ▲▼** buttons to place the TV in the **EXPANDED** sound mode.

- 3 Press the **STATUS** button to clear the screen.

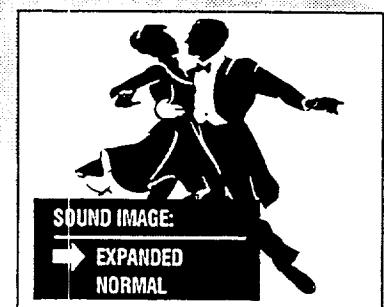
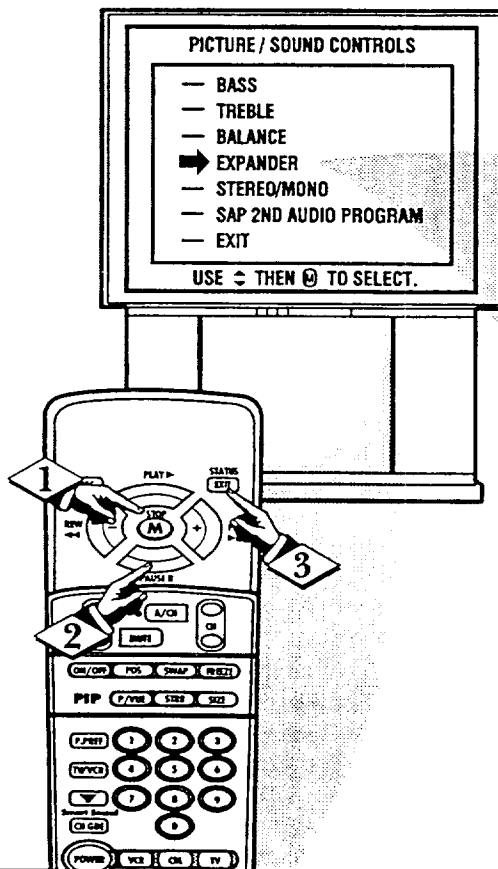

STEREO/MONO

Your TV is able to receive broadcast stereo TV programs. The TV is equipped with an amplifier and twin speaker system through which the stereo sound can be heard.

A RED stereo light (on the front of the TV) will come on when a stereo broadcast is received.

BEGIN

- 1 Select **STEREO** sound control.

With the PICTURE/SOUND CONTROLS on screen, press the MENU ▲▼ buttons to move the red arrow. Then press MENU button.

- 2 Press the MENU ▲▼ buttons to place the TV in the **STEREO** sound mode.

- 3 Press the **STATUS** button to clear the screen.



Remember. If a stereo signal is not available and the TV is placed in the **STEREO** mode, sound coming from the TV will remain monaural (mono).

SECOND (2ND) AUDIO PROGRAM (SAP)

PROGRAM (SAP) is part of the stereo broadcast system. Sent as a third audio channel SAP can be heard apart from the current TV program sound. TV stations are free to use SAP for any number of purposes, but many experts believe it will be used for foreign language translations of TV shows (or for weather and news bulletins.)

Remember. If a SAP signal is not present with a selected program, the SAP option can not be selected. "SAP NOT AVAILABLE" will appear on the TV screen.

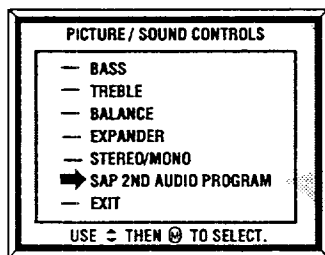
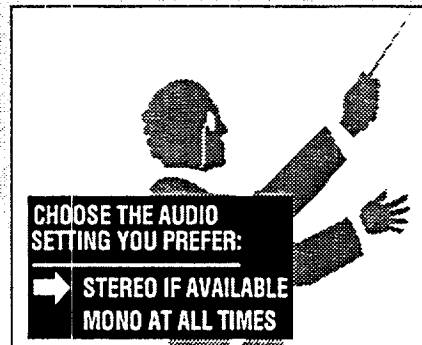
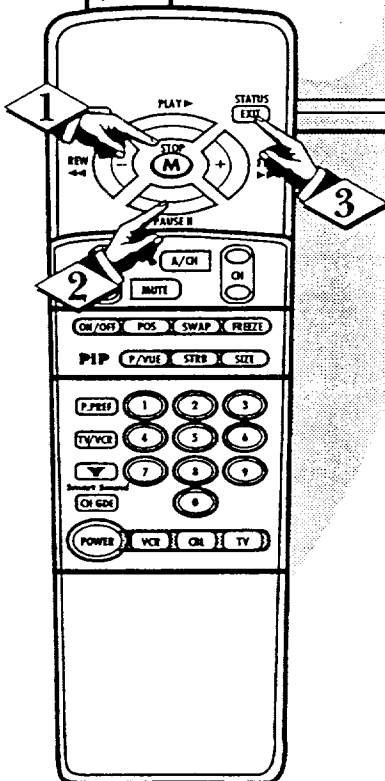
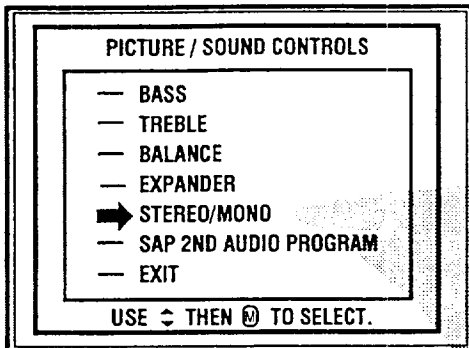

THIS CONTROL SCREEN WILL ONLY APPEAR IF SAP IS AVAILABLE ON THE CURRENT CHANNEL.

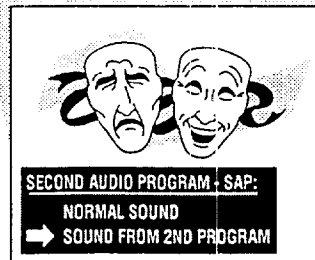

TO SELECT ADVANCED CONTROLS

BEGIN

- 1 Press **MENU** button to see TV ADJUSTMENTS screen.
- 2 Press **MENU ▲** or **▼** button to move RED ARROW to ADVANCED controls.
- 3 Press **MENU** button to select the list of ADVANCED controls.

STOP

Remember, the control with the RED ARROW is ready to be used. Just press the **MENU** button to select it.

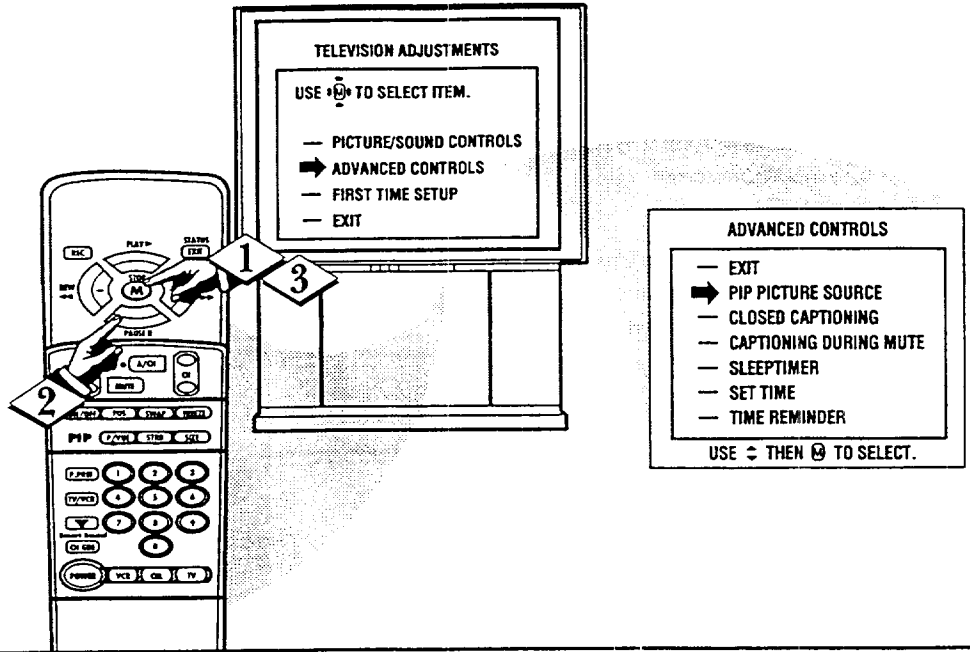

SET TIME

Your TV comes with an on-screen clock. During normal operation the clock appears on the screen with every channel change (and when the **STATUS** button is pressed).

BEGIN

- 1 Select **SET TIME** control.
- With the **ADVANCED CONTROLS** on screen, press the **MENU ▲▼** buttons to move the red arrow. Then press **MENU** button.
- 2 Press the **MENU ▲▼** buttons to set the minutes portion of the clock.
 - 3 Press the **M (+)** or **(-)** buttons to move the selection arrow to the hours portion of the clock.
 - 4 Press the **M ▲▼** buttons to set the hours portion of the clock.
 - 5 Press the **STATUS** button to set the clock in operation and clear the screen.

STOP

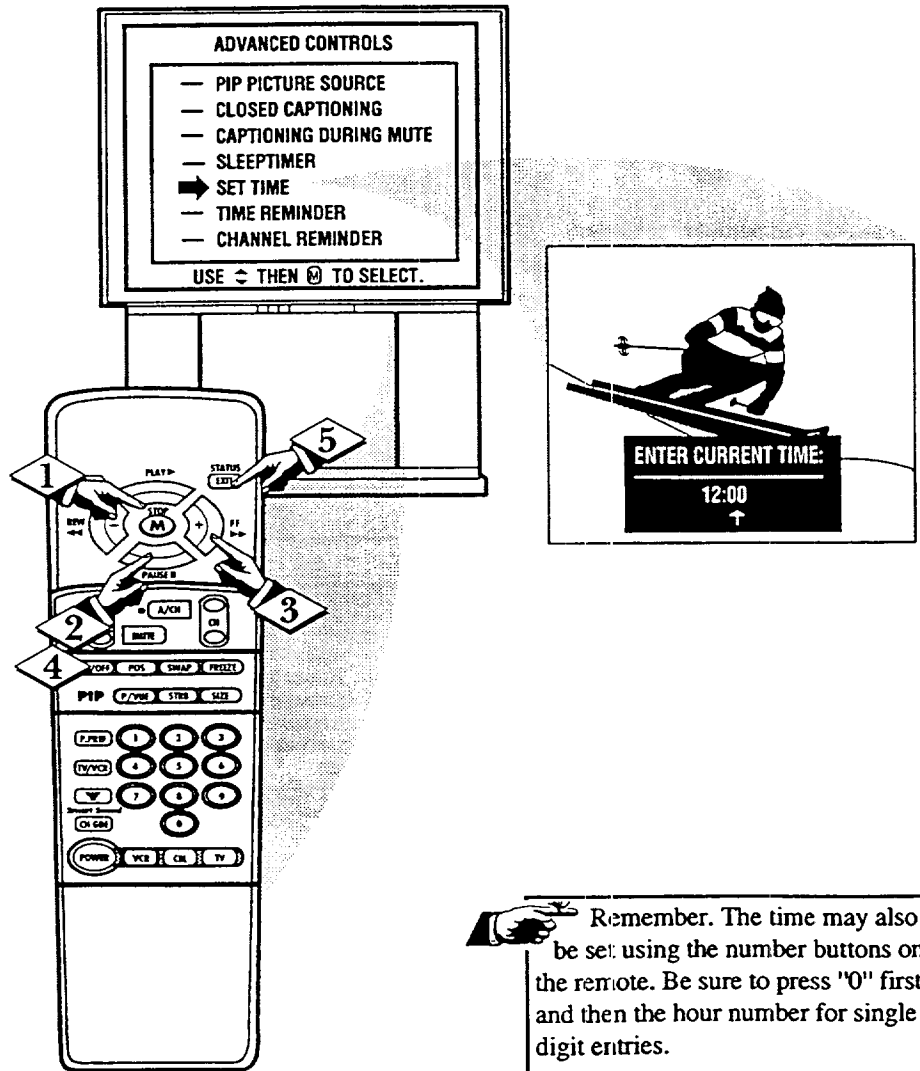

Remember. The time may also be set using the number buttons on the remote. Be sure to press "0" first and then the hour number for single digit entries.

CLOSED CAPTIONING

Closed Captioning (CC) allows you to read the voice content of television programs on the TV screen. Designed to help the hearing impaired this feature uses on-screen "text boxes" to show dialogue and conversations while the TV program is in progress.

BEGIN

- 1 Select **CLOSED CAPTIONING** control.

With the **ADVANCED CONTROLS** on screen, press the **MENU** ▲▼ buttons to move the red arrow. Then press **MENU** button.

- 2 Press the **MENU** ▲▼ buttons to select the desired Closed Caption mode - For Example: **STANDARD**.

STANDARD (CC1) :

dialogue (and descriptions) for the action on the captioned TV program shows on-screen. (See important note on this page.)

SECOND LANGUAGE (CC2) :

foreign language translation of dialogue (and descriptions) for the action on the captioned TV program shows on-screen.

FULL SCREEN TEXT 1 or 2:

often used for channel guide, schedules, or bulletin board information for CC programs.

- 3 After making your Caption mode selection, press the **STATUS** button to clear the TV screen. The selected Closed Caption mode will be active.

To cancel, set the Closed Captioned feature to **OFF** when finished viewing.



Remember. Broadcast stations will often use spelling abbreviations, symbols, dropouts and other grammatical shortcuts in order to keep pace with the on-screen action. These type factors vary upon the source of the captioned text material and do not indicate a need for service on the part of the TV.

NOTE: Not all TV programs and product commercials are made for broadcast with Closed Caption (CC) information included. Neither are all Closed Caption modes (SECOND LANGUAGE, FULL SCREEN TEXT1, etc.) necessarily being used by a broadcast station during the transmission of a closed caption program. Refer to your area's TV program listings for the stations and times of Closed Caption shows.

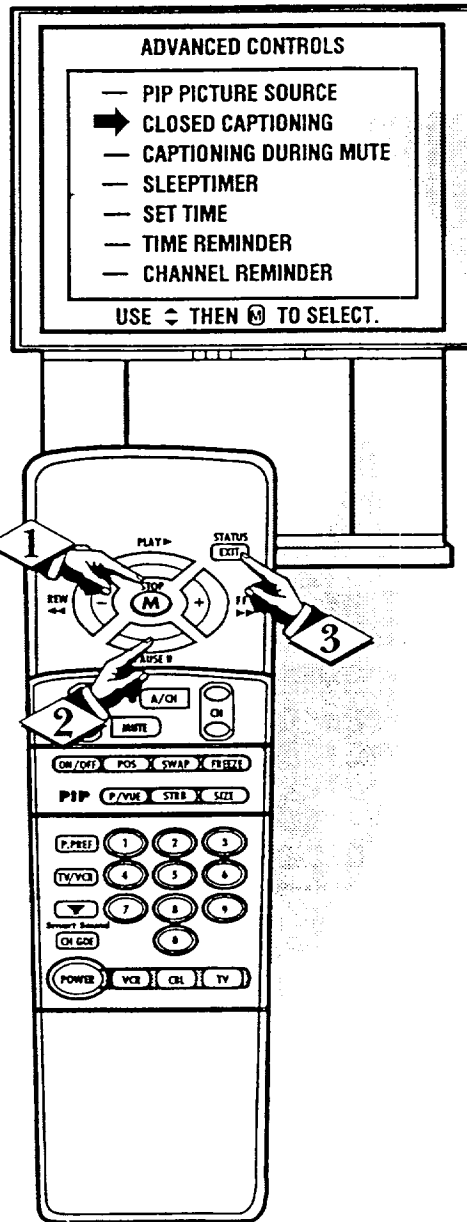

ADVANCED CONTROLS

- PIP PICTURE SOURCE
- ➔ **CLOSED CAPTIONING**
- CAPTIONING DURING MUTE
- SLEEPTIMER
- SET TIME
- TIME REMINDER
- CHANNEL REMINDER

USE ◀ THEN Ⓜ TO SELECT.

NOTE: The **CAPTIONING DURING MUTE** control can be used to set the TV to turn the Closed Caption mode "ON" whenever the **MUTE** button on the remote is pressed.

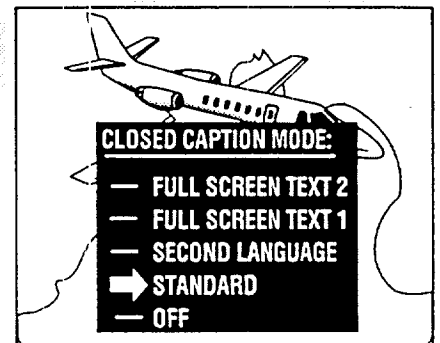

STANDARD mode
Example Type Display

Closed Caption information will usually appear in black and white (although some broadcasters or networks may occasionally use color to highlight or draw attention to certain areas.

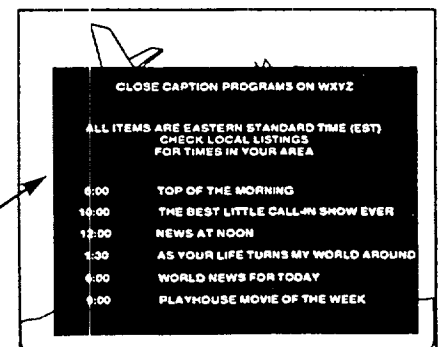

FULL SCREEN TEXT1 & TEXT 2 modes
will block TV screen from viewing

SLEEP TIMER

Have you ever fallen asleep in front of the TV and then have it wake you up at two in the morning with a test pattern screeching in your ears? Well, your TV can save you all that trouble by automatically turning itself off.

BEGIN

1 Select **SLEEP TIMER** control.

With the **ADVANCED CONTROLS** on screen, press the **MENU** \blacktriangle \blacktriangledown buttons to move the red arrow. Then press **MENU** button.

2 Press the **(+)** button repeatedly to select the amount of time before the TV will turn OFF.

The TV can be set to cut itself off anywhere from 15 minutes to 4 hours away.

3 Press the **STATUS** button to clear the screen.



Remember. If you ever want to see how many minutes are left before the TV shuts off, select the **SLEEP TIMER** control display.

If you ever want to stop a **SLEEP TIMER** setting, reset the timer to 0:00. Turning the TV off and then back on also cancels a setting.

A few seconds before the TV is to shut off a message will come on the screen telling you **GOOD NIGHT**.

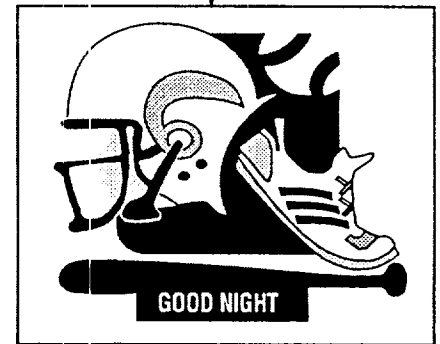
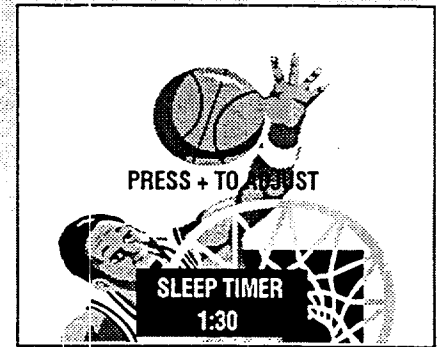
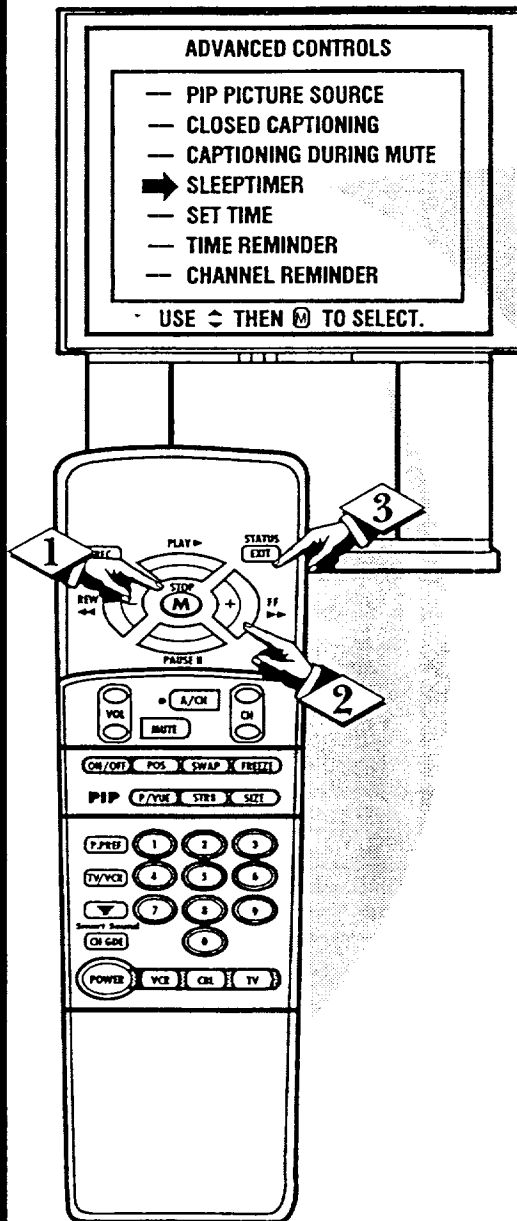

TIME/CHANNEL REMINDER

With the TV Reminder controls ON, the TV automatically shows you the current time and channel every thirty minutes.

BEGIN

- 1 Select TIME or CHANNEL REMINDER control.

With the ADVANCED CONTROLS on screen, press the MENU ▲▼ buttons to move the red arrow. Then press MENU button.

- 2 Press the MENU ▲▼ buttons to turn the Reminder controls ON.

- 3 Press the STATUS button to clear the screen.



Remember. The TIME and CHANNEL Reminders appear on the hour and the half-hour for about five seconds.

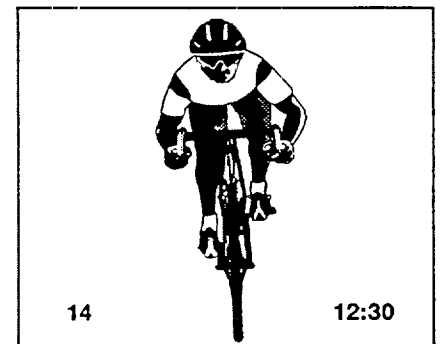
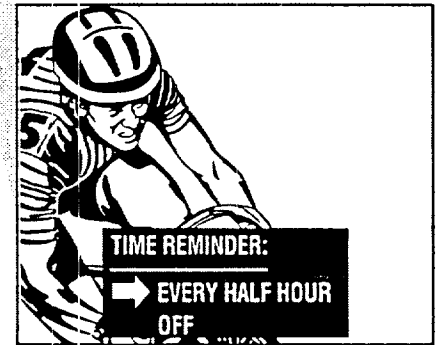
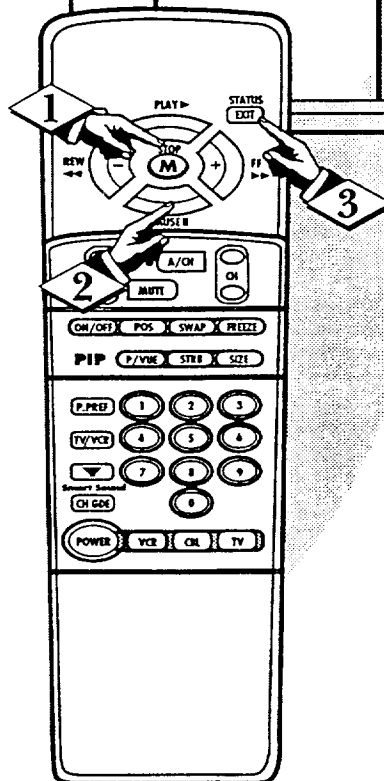
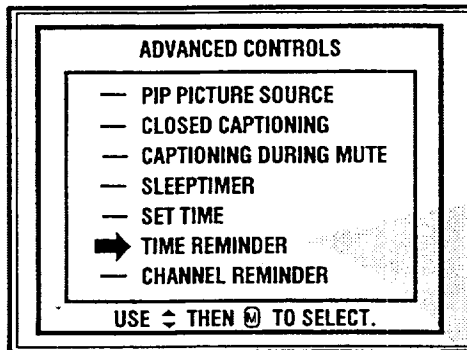

TIME AND CHANNEL REMINDERS DISPLAYED

CHANNEL/TIME DISPLAY SIZE

With the Channel/Time Display control you can change the size and location of the on screen channel and clock information.

BEGIN

- 1 Select CHANNEL/TIME DISPLAY SIZE control.

With the ADVANCED CONTROLS on screen, press the MENU ▲▼ buttons to move the red arrow. Then press MENU button.

- 2 Press the MENU ▲▼ buttons to turn the LARGE or SMALL DISPLAY control ON.

- 3 Press the STATUS button to clear the screen.



Try it out. Press the STATUS or CHANNEL ▲▼ buttons and you should see the Display Size you selected.

Remember. The SMALL SIZE display shows only the channel number, not the time (or clock).

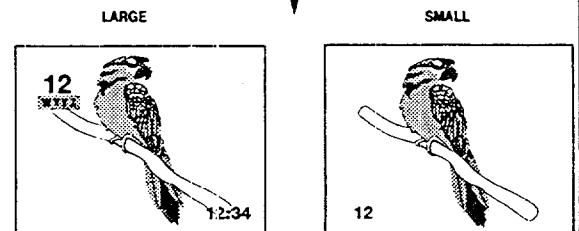
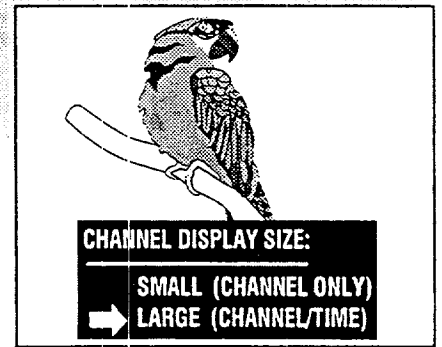
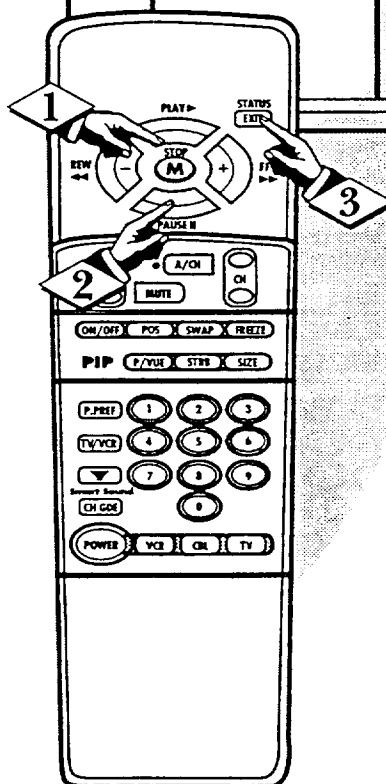
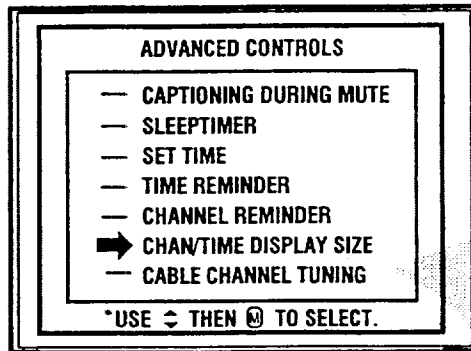

CHANNEL/TIME DISPLAY OPTIONS

CABLE CHANNEL TUNING

If you didn't go through the **FIRST TIME SETUP** (page 8), you need to make sure the TV is set to pick up either Cable TV or Antenna signals. In other words, the TV needs to know if you connected a Cable TV signal or a normal antenna to its **ANTENNA** plug.

BEGIN

- 1 Select **CABLE CHANNEL TUNING** control.

With the **ADVANCED CONTROLS** on screen, press the **MENU ▲▼** buttons to move the red arrow. Then press **MENU** button.

- 2 Press the **MENU ▲▼** buttons to place the TV in either:

CABLE- If you **DO** have Cable TV connected to the TV. Channels 1-125 available.

ANTENNA- If you have an Antenna connected to the TV. Channels 2-69 available.

- 3 Press the **STATUS** button to clear the screen.

STOP

Remember. The **FIRST TIME SETUP** procedure (page 8) does all this for you automatically.

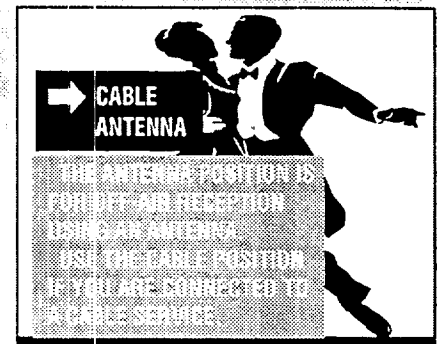
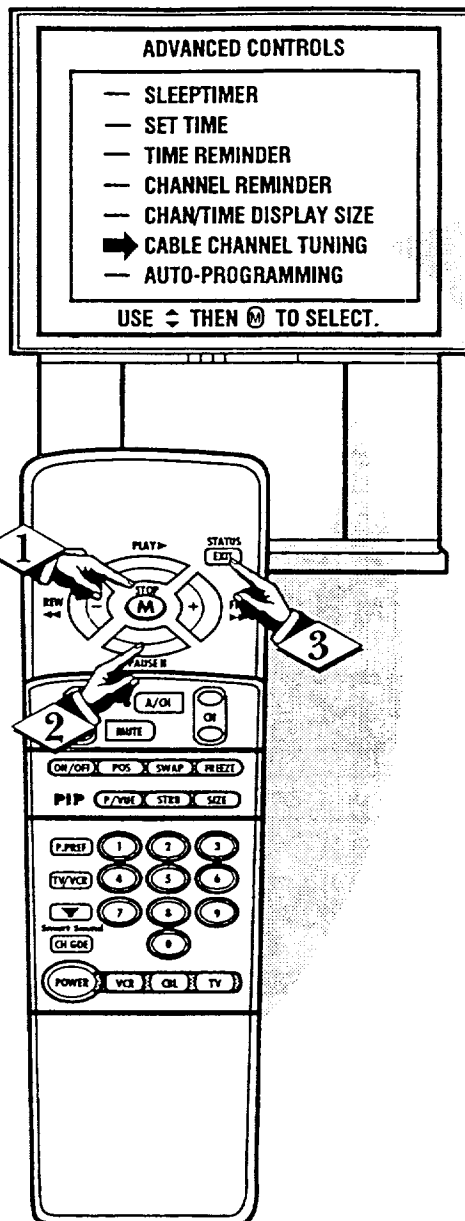

AUTO-PROGRAMMING

Auto-Programming is for adding local area channel numbers into the memory of the TV. This makes it easy for you to select only your area (or Cable TV) channels when the CHANNEL ▲▼ buttons are pressed. If you already went through **FIRST TIME SETUP** (page 8), this task has been completed for you.

BEGIN

1 Select **AUTO PROGRAMMING** control.

With the **ADVANCED CONTROLS** on screen, press the **MENU ▲▼** buttons to move the red arrow. Then press **MENU** button.

2 Press the **MENU ▲▼** buttons to turn **AUTO PROGRAMMING ON**.

The TV shows which channel numbers are "SAVED" as they are added into memory. "AUTO PROGRAMMING COMPLETED" appears when the TV is finished adding channels.

3 Press the **STATUS** button to clear the screen.



Try it out. Press the **CHANNEL ▲▼** buttons and see which channels you can select.

Remember. An Antenna or Cable TV signal must first be connected to your TV so that channels can be saved.

If you want to delete any unwanted channels from the TV's memory, see "ADD/DELETE CHANNELS" on the next page.

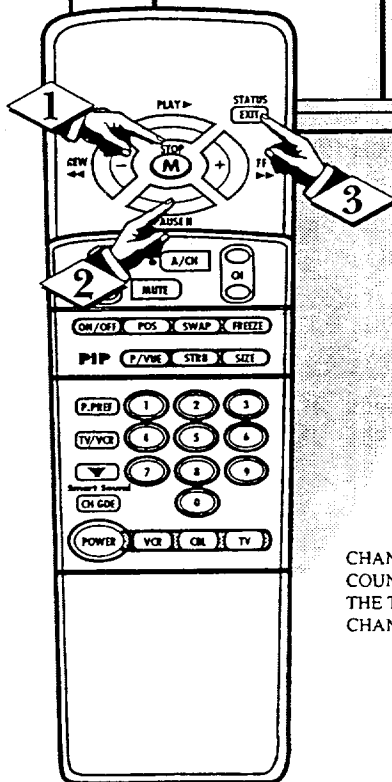
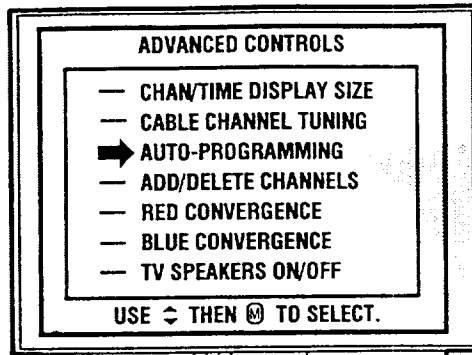

CHANNEL NUMBERS COUNT UPWARD AS THE TV LOOKS FOR CHANNELS TO SAVE.

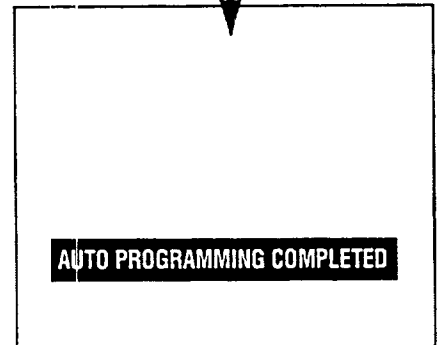
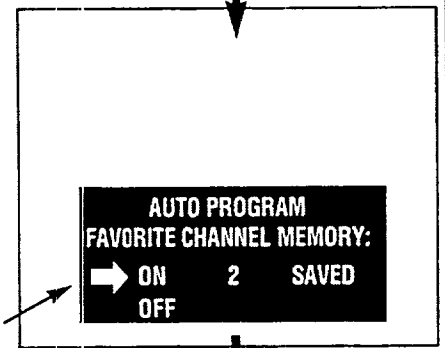
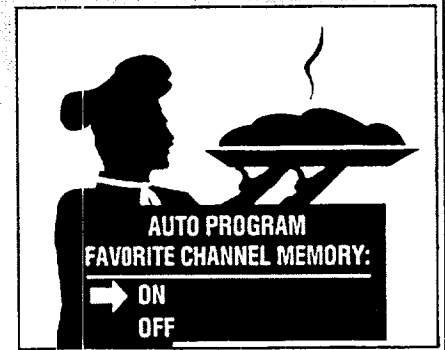

ADD/DELETE CHANNELS

AutoProgramming (see previous page) adds all the channels it can find (on your Antenna or Cable TV system) into the TV's memory. Add/Delete Channels makes it easy for you to add other channels, or drop unwanted channels, from the list of channels in the TV's memory.

BEGIN

- 1 Select ADD/DELETE CHANNELS control.

With the ADVANCED CONTROLS on screen, press the MENU ▲▼ buttons to move the red arrow. Then press MENU button.

- 2 Press the CHANNEL ▲▼ buttons to select the channel you want to add or delete.

You can also use the Channel number buttons on the remote to select channels.

- 3 Press the (+) button to ADD the channel into the TV's memory. Press the (-) button to DELETE the channel from memory.

Repeat steps 2 and 3 for each channel you wish to add or delete.

- 4 Press the STATUS button to clear the screen when through.



 Remember. You can also add the VCR/AUX1 (or AUX2 mode) just like a channel. Then by pressing the CHANNEL ▲▼ buttons the VCR/AUX1 (or AUX2) mode can quickly be selected to use the Audio/Video Input jacks on the rear of the TV (see page 34).

Note: The "VCR/AUX1 and AUX2 modes are located between the lowest and highest channel numbers within the Favorite Channel Memory control screen.

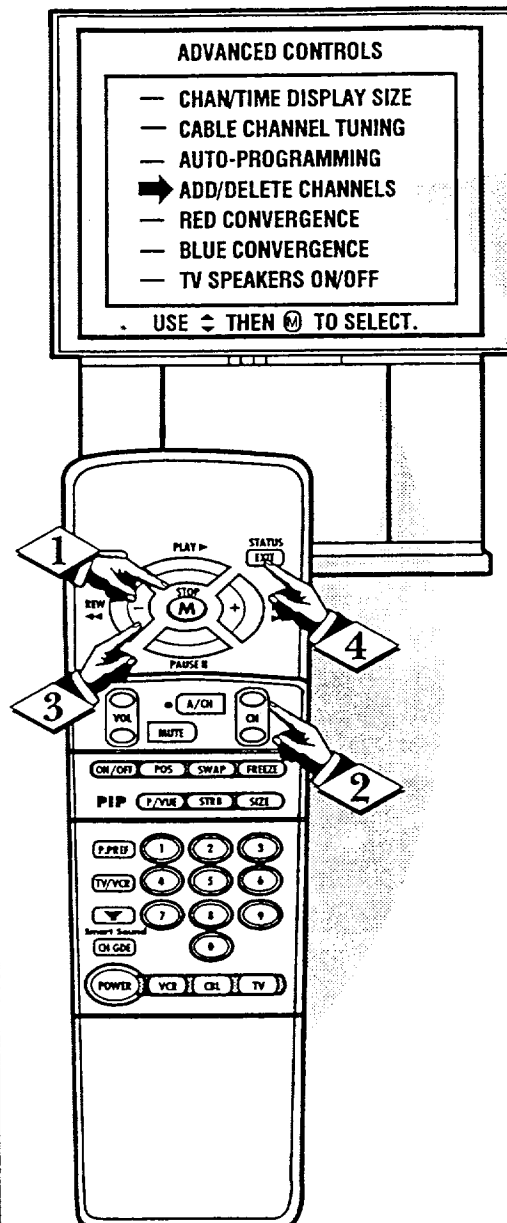

RED/BLUE CONVERGENCE

Convergence is the correct lining up of the red and blue light paths on the TV screen.

NOTE: If no color fringing (see sidebar note) shows, then no Convergence adjustments are necessary for your TV.

BEGIN

- 1 Select RED or BLUE CONVERGENCE control.

With the ADVANCED CONTROLS on screen, press the MENU ▲▼ buttons to move the red arrow. Then press MENU button.

- 2 Press the MENU ▲▼ and (+) (-) buttons to move the red or blue cross directly over the white cross on the TV screen.

The red or blue cross is properly adjusted when it is completely merged with the white cross. (No color appears around the edge of the white cross).

- 3 Press the STATUS button to clear the screen when convergence adjustments are complete.

STOP

Remember. Convergence has been set at the factory for best viewing, but if one or more of the (red or blue) colors appear around the edges of objects (color fringing) follow the steps given in this section.

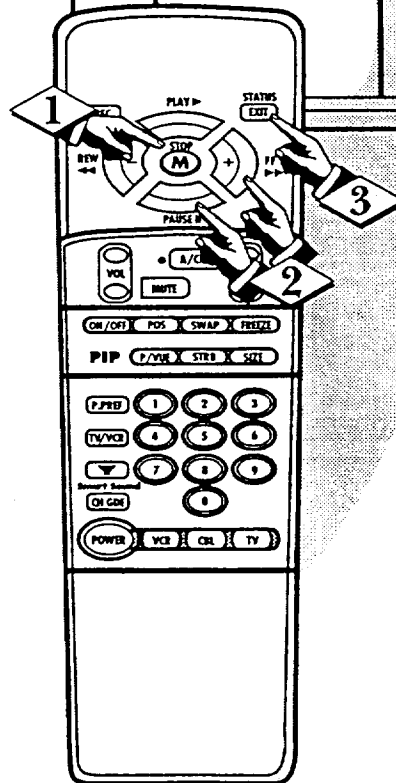
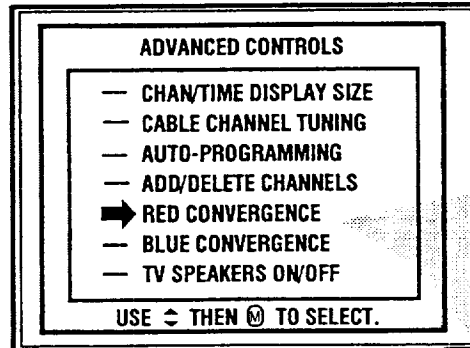

TV SPEAKERS ON/OFF

Would you like to hear TV programs through your audio hi-fi system? The TV's Variable Audio Output jacks and TV Speaker On/Off control work together to offer you this TV sound option.

BEGIN

- 1 Connect the R(ight) and L(eft) VARIABLE MODE Audio Out jacks on the TV to the R and L Audio Input jacks on your amplifier or sound system.

Set the audio system's volume to normal listening level.

- 2 Turn the TV and audio system ON. You can now adjust the sound level coming from the audio system with the Volume ▲▼ buttons on the TV or remote.

- 3 To hear the TV sound from only the audio system speakers, select TV SPEAKERS ON/OFF control.

With the ADVANCED CONTROLS on screen, press the MENU ▲▼ buttons to move the red arrow. Then press MENU button.

- 4 Press the MENU ▲▼ buttons to turn the TV Speakers OFF.

You should now only hear TV sound coming from the audio system speakers.

- 5 Press the STATUS button to clear the screen.

STOP

Remember. The audio system may have to be in AUX(iliary) mode to play sound from the TV.

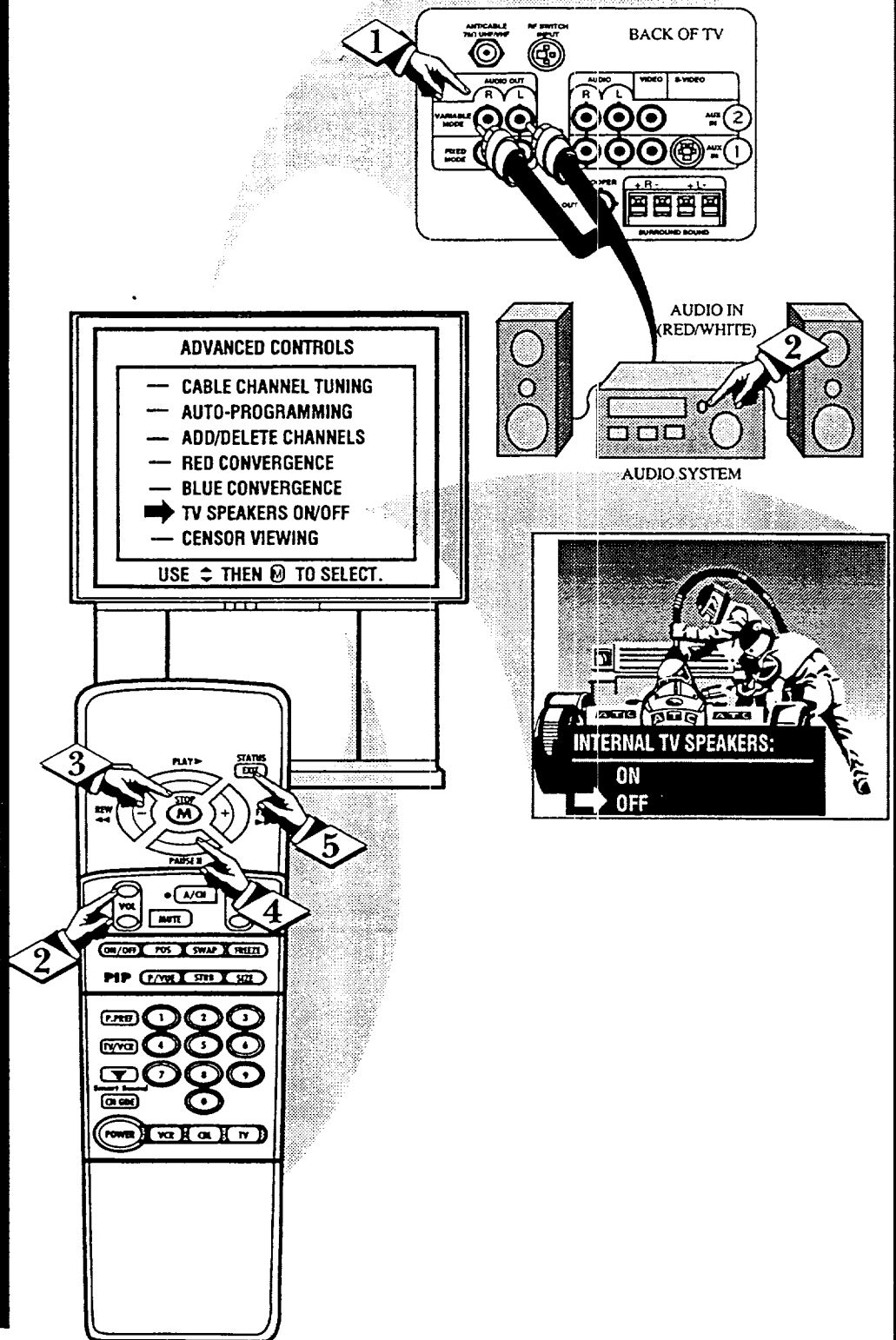

CENSOR VIEWING

Censor Viewing allows parents to block out, or "censor", any channels they think children should not watch. A channel placed under Censor Viewing cannot be viewed until a correct access code is used to unlock the channel for viewing.

First let's set your Censor Code:

BEGIN

- 1 Select the **CHANGE CENSOR CODE** control.

With the **ADVANCED CONTROLS** on screen, press the **MENU** ▲▼ buttons to move the red arrow. Then press **MENU** button.

"ENTER CURRENT CODE" shows on the screen.

- 2 Press 0, 7, 1, 1 on the remote.

"XXXX" shows on the screen as you press the number buttons.

"INCORRECT ACCESS CODE" will also show on the screen.

- 3 Press 0, 7, 1, 1 on the remote again.

"ENTER NEW CODE" shows on the screen.

- 4 Enter a new four digit number code using the remote.

"ACCESS CODE REPROGRAMMED" shows on the screen to let you know the new code has been set.

- 5 Press the **STATUS** button to clear the screen.



Remember. After you set the new Censor Code go on to the next page to see how to place channels under Censor Viewing control.

Parents - it isn't possible to unlock or defeat your Censor Code without changing to a new code number. So if your Code number changes, and you didn't change it yourself, then you will know that someone has altered the code and the blanked out channel has been viewed.

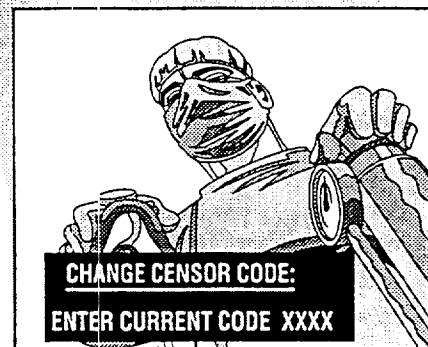
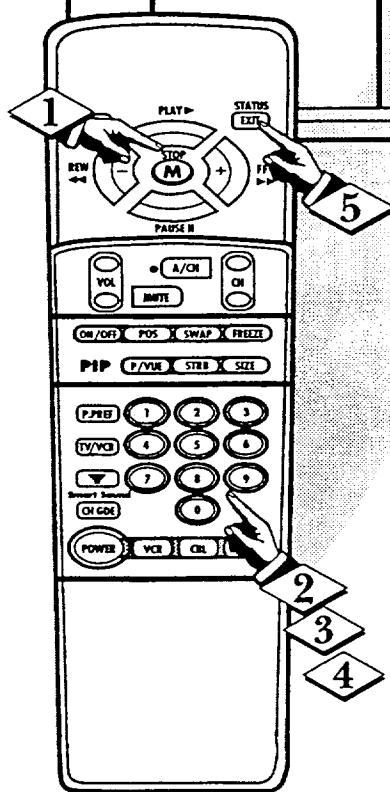
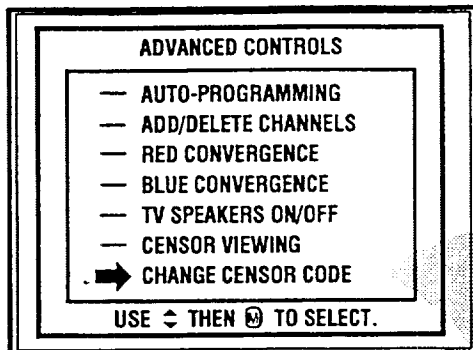

INCORRECT ACCESS CODE

CHANGE CENSOR CODE:
ENTER CURRENT CODE XXXX

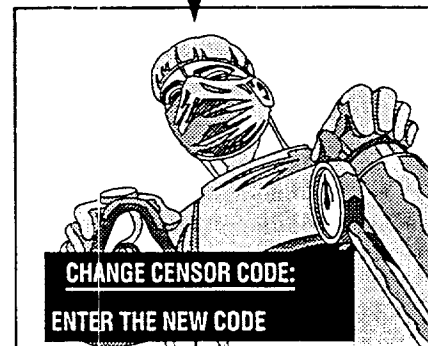

ACCESS CODE REPROGRAMMED

CENSOR VIEWING (CONTINUED)

After your personal Censor Code number has been set (see previous page), you are now ready to select the channels you want to censor or block out.

BEGIN

- 1 Select the CENSOR VIEWING control.

With the ADVANCED CONTROLS on screen, press the MENU ▲▼ buttons to move the red arrow. Then press MENU button.

"ENTER CURRENT CODE" shows on the screen.

- 2 Enter the correct Censor Code number.

- 3 Press Channel ▲▼ or Channel Number buttons to select the channel to be censored.

- 4 Press the (+) button to "BLOCK VIEWING" on the selected channel. Press the (-) button to "ALLOW VIEWING" on a blocked channel. Repeat steps 4 and 5 for any other channels you wish to block out.



Remember. You can also block out the use of the Audio/Video Input jacks on the TV. This stops the viewing of VCR programs which can be shown through the A/V IN jacks. Just select VCR/AUX1 or AUX2 (located between the lowest and highest channel numbers) on the Censor Viewing screen, and select Block Viewing.

Note: To make TV viewing easier all channels (and Audio/Video Input jacks) will be unblocked, once the correct Censor Code number has been entered for one blocked out channel.

When the TV is turned OFF and then back ON again, Censor Viewing is back in place for all channels.

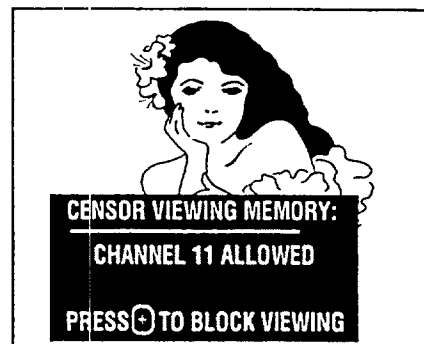
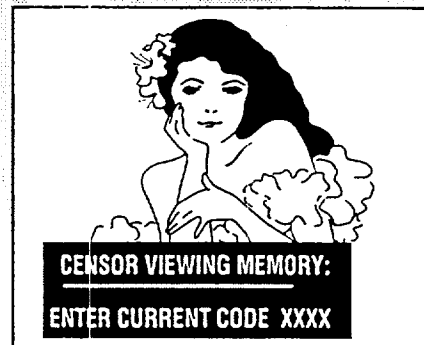
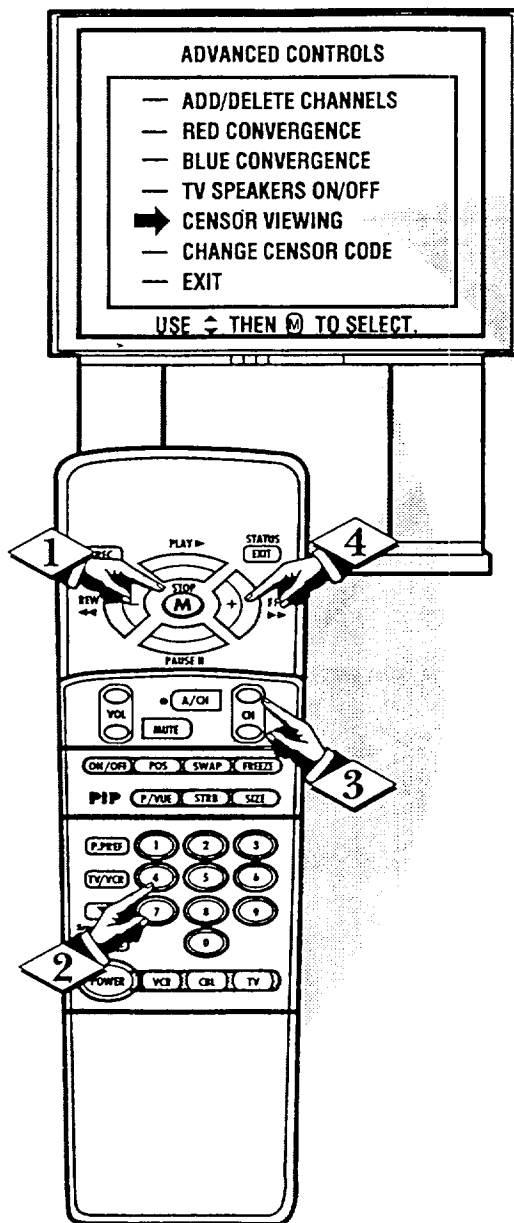

VCR/AUX1 INPUTS

The TV's Audio/Video Input jacks are for direct picture and sound connections between the TV and a VCR (or Video Disc Player, etc.) that has Audio/Video Output jacks.

To view the playback of a VCR tape by using the Audio/Video Input jacks on the TV:

BEGIN

1 Connect the VIDEO OUT jack from the VCR to the VCR/AUX1 VIDEO IN jack on the TV.

2 Connect the AUDIO OUT jacks R(ight) and L(eft) from the VCR to the VCR/AUX1 AUDIO IN jacks on the TV.

3 Select the VCR/AUX1 PICTURE SOURCE control. on the TV. Try any of the three following ways:

An easy way to select VCR/AUX1 is to press the VCR button on the front of the TV.



If you have added VCR/AUX1 to the TV's channel memory (see page 29), press the CHANNEL ▲▼ buttons to select it.



With the PICTURE/SOUND CONTROLS (see page 16), move the red arrow with the MENU ▲▼ buttons to PICTURE SOURCE. Then select VCR/AUX1.

4 Turn the VCR ON and press PLAY to view the tape on the TV.



Remember. Connections and use of the TV's AUX2 Audio/Video Input jacks are the same as for the AUX1 jacks (except "AUX2" is selected as the Picture Source - step 3).

If you have a single (monaural) Audio Output VCR, "Y" connectors are available to complete your connection. Contact your dealer, or our Parts Information Center, for details.

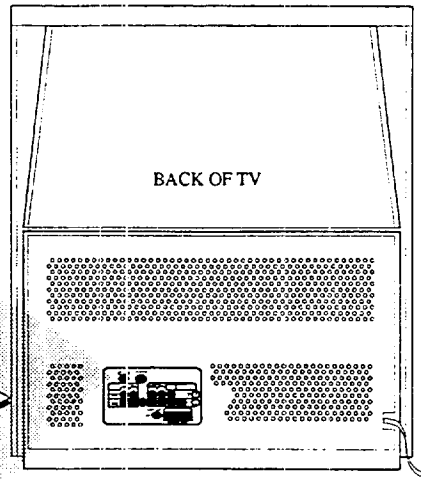
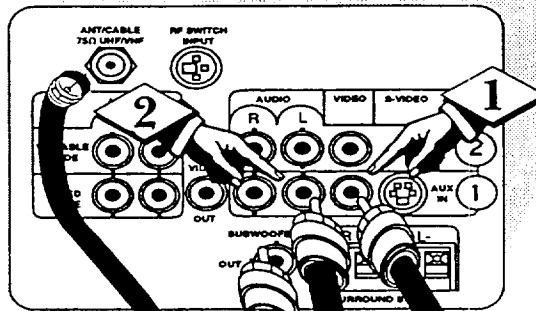

Contact your dealer or Parts Information Center (1-800-292-6066) to order any optional accessories.

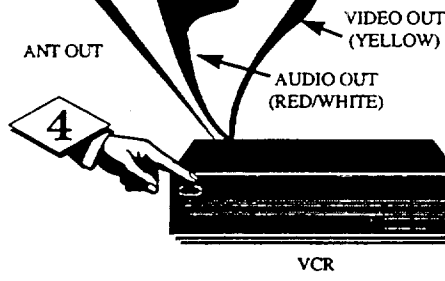

OUTDOOR VHF/UHF ANTENNA



ANT IN



CABLE TV SIGNAL

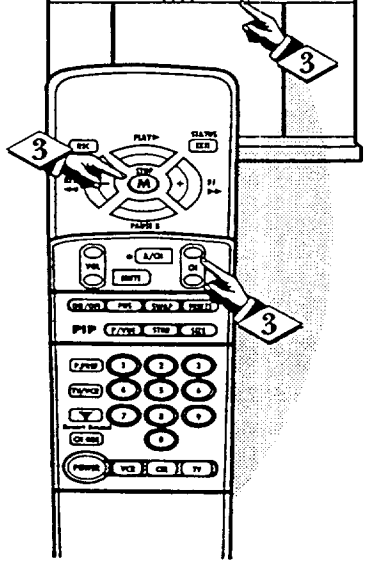
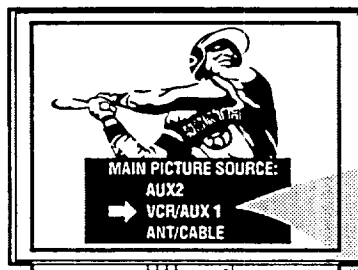

PICTURE AND SOUND FROM PLAYBACK OF VCR TAPE

VCRAUX1 - S-VIDEO INPUTS

The S(uper)-Video connection on the rear of the TV can give you better picture detail and clarity, for the playback of S-VHS VCR tapes or Video Discs, than the normal antenna picture connections.

Note: The VCR (or Video Disc Player) must have a S-VIDEO OUT(put) jack in order for you to complete the connections shown on this page.

BEGIN

1 Connect the S-VIDEO (S-VHS) OUT jack from the VCR to the AUX IN1 S-VIDEO jack on the TV.

2 Connect the AUDIO OUT jacks R(ight) and L(ef) from the VCR to the AUX IN1 jacks on the TV.

3 Select the S-VIDEO 1 PICTURE SOURCE control. Try any of the three following ways:

An easy way to select S VIDEO 1 is to press the VCR button on the front of the TV.



If you have added VCR/AUX1 to the TV's channel memory (see page 29), press the CHANNEL ▲▼ buttons to select S VIDEO 1.



With the PICTURE/SOUND CONTROLS (see page 16), move the red arrow with the MENU ▲▼ buttons to PICTURE SOURCE. Then select S VIDEO 1.

4 Turn the VCR ON and place it in the S-VIDEO (or S-VHS) playback mode. Insert S-VHS cassette tape and playback in a normal manner.



Remember. The S-VIDEO connecting cable will be supplied with the S-VHS VCR (or Video Disc Player).

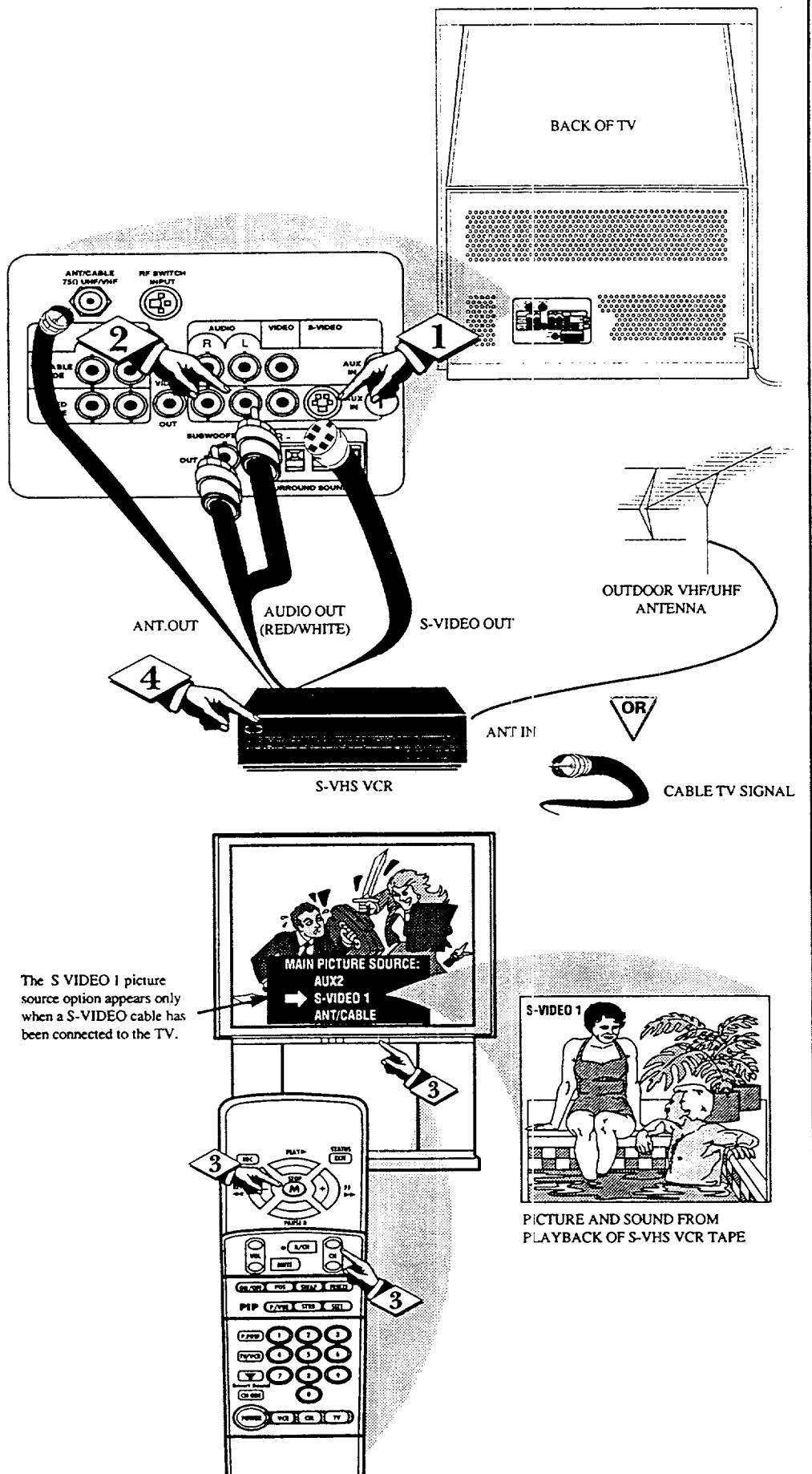

TV AUDIO/VIDEO OUTPUTS

The Audio/Video Output jacks on the TV can be used to record TV programs on VCRs which have Audio/Video Input jacks.

To record TV programs by using the Audio/Video jacks on the TV:

BEGIN

1 Connect the VIDEO OUT jack from the TV to the VIDEO IN jack on the VCR.

2 Connect the FIXED MODE AUDIO OUT jacks R(right) and L(left) from the TV to the AUDIO IN jacks on the VCR.

3 Select the PICTURE SOURCE control on the TV.

With the PICTURE/SOUND CONTROLS on screen, move the red arrow with the MENU ▲▼ buttons to PICTURE SOURCE. Then select "ANT/CABLE".

Select the channel on the TV that you want to record.

4 Turn the VCR ON. Put a cassette tape in the unit and place the VCR in the RECORD mode.

STOP

Remember. If the VCR has an INPUT SELECTOR switch, place it in the LINE or CAMERA position.

Unattended Timer Recordings with a VCR are possible, but not recommended with this connection, since the TV must be left ON for the VCR to record.

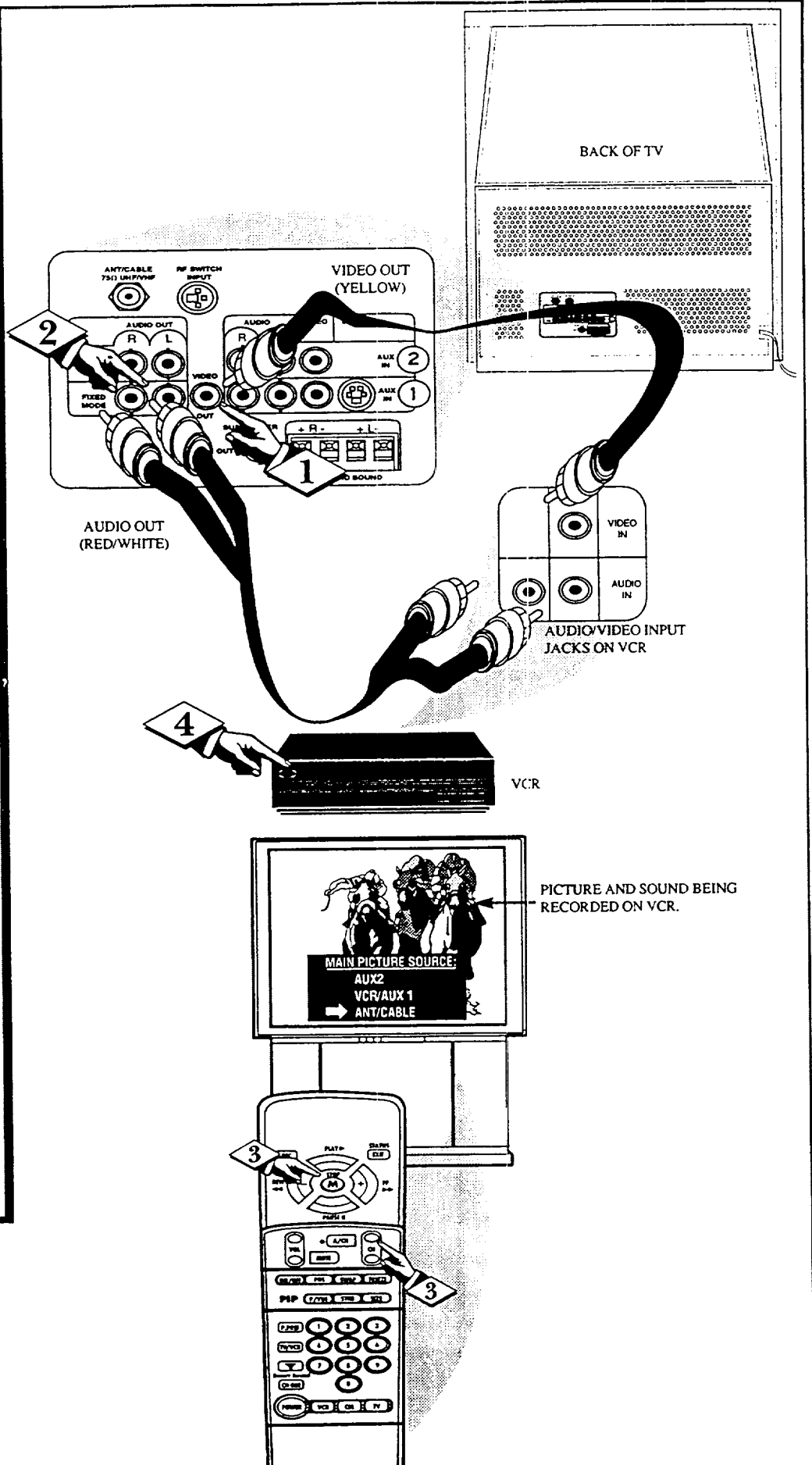

SURROUND SOUND

By adding external speakers to the TV's sound system, you can create the feeling of reflected sound that surrounds you at a movie theater or concert hall.

BEGIN

- 1 Connect both external speakers to the speaker wire terminals on the TV.

Recommended speakers: 8ohm, 15 watt minimum. Be sure the (+) and (-) speaker wires are connected to the correct R(ight) and L(ef) speaker terminals on the TV.

- 2 Place the speakers so the viewing area is between the TV and the rear surround speakers.

- 3 Turn TV ON and place the STEREO/MONO control to STEREO position.

After setup whenever a stereo signal is received the audio will be heard in Surround Sound.

Note: The rear Surround Sound speakers will not be heard at the same volume level as the front TV speakers. It is intended for the rear speakers to give a background noise effect which requires a lower volume level than the TV's front speakers.



Remember. An optional SUBWOOFER "Amplifier - Speaker" can also be connected to the TV. The Subwoofer jack on the TV outputs a low level Bass signal. When this jack is connected to an Amplifier Subwoofer speaker it complements the sound coming from the rear Surround speakers. Contact your dealer for more information if you would be interested in adding such an accessory to your home audio system.

For an added dimension of Surround Sound you may also want to place the TV in the EXPANDED mode (see page 20).

Note: Surround Sound will not work with monaural audio material, or with only one speaker connected.

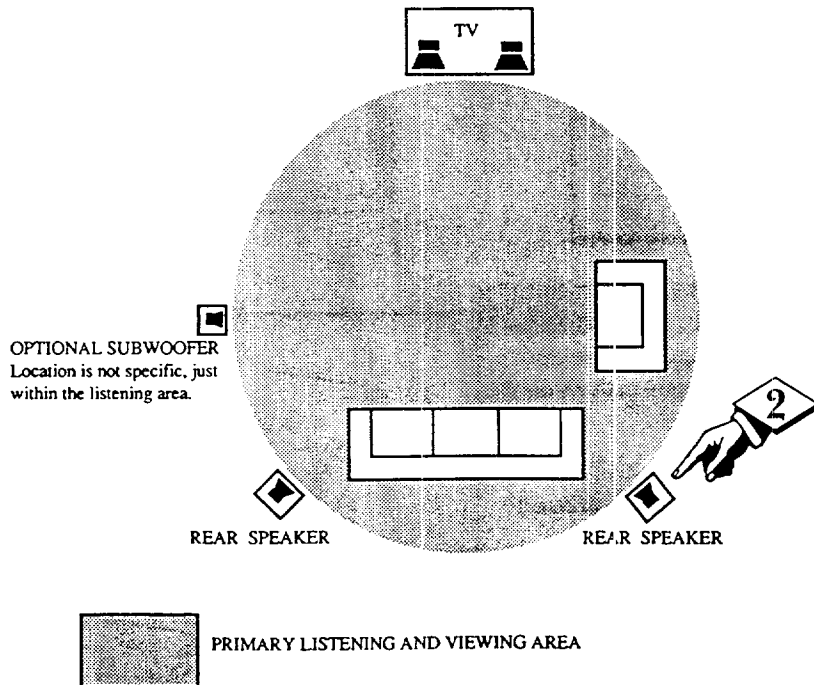
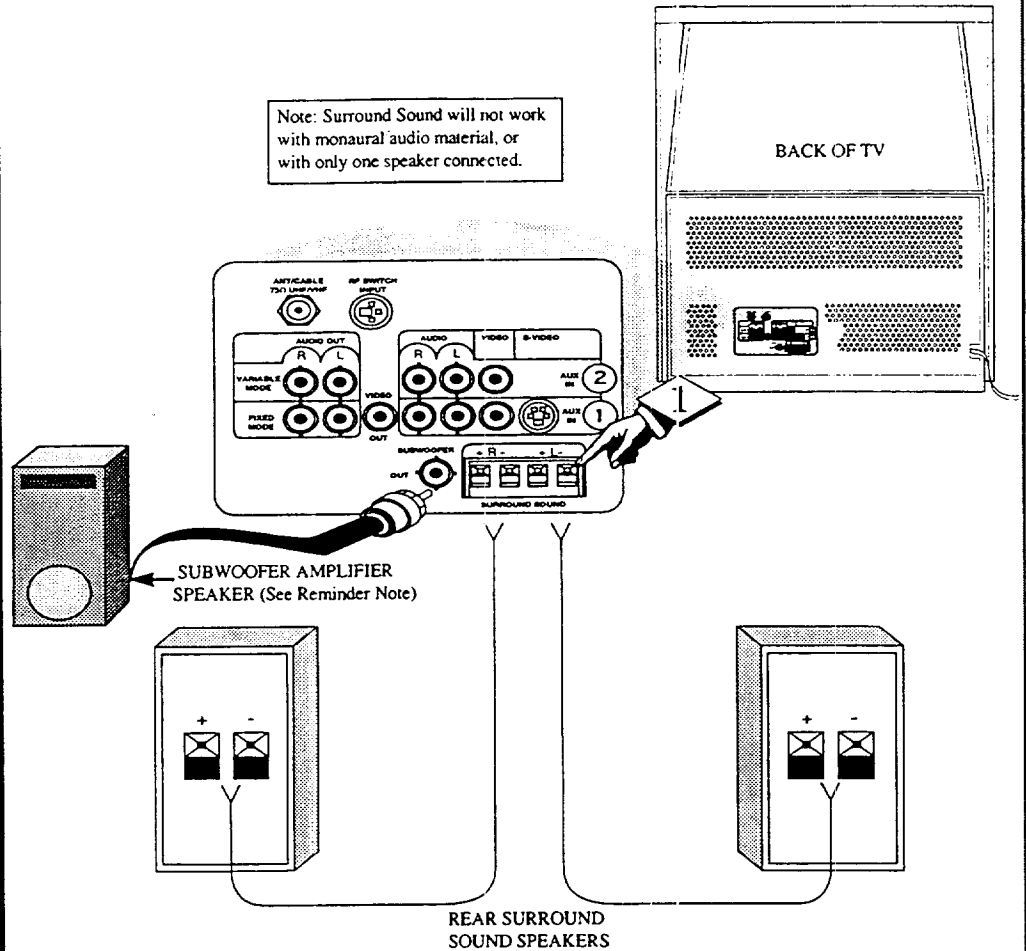

BASIC REMOTE CONTROL OPERATION

After installing the batteries into the remote, press the TV System button to send remote commands to the TV. Point the remote toward the front of the TV (remote sensor window) when pressing buttons.

VCR Buttons

For use of VCR buttons see the "Using the Remote With a VCR".

Menu (▼▲) Buttons

Press the M button to show on-screen feature controls. Press ▲ or ▼ buttons to move forward and backward through the list of on-screen controls.

(-) and (+) Buttons

Press to adjust the selected on-screen feature control.

Volume Button

Press to adjust the TV sound level.

Personal Preference Button

Press to return the TV to specific picture and sound settings you have placed in the TV's memory. Also can be used as an Enter button when sending channel commands to remote controlled cable converters or VCRs.

Smart Sound Button

Press to control TV sound levels. See "Smart Sound/Auto Volume" section for details.

Channel Guide Button

Press to show a list of labelled TV channels from which to select. See "CH GUIDE" section for details.

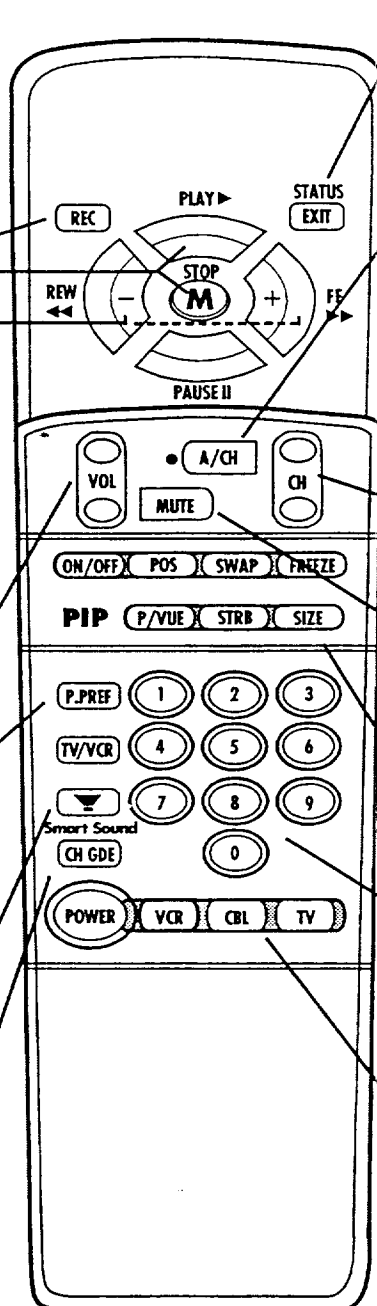

Status/Exit Button

Press to see the current channel number on the TV screen. Also press this button to clear the TV screen after control adjustments.

Alternate Channel Button

Press to select the previously viewed channel.

For example: You are watching channel 4 and change to channel 10 (using the channel number buttons). Press A/CH and your TV will return to channel 4. Press A/CH again and your TV will return to channel 10.

Channel Scan Button

Press to scan up or down through channel numbers.

Mute Button

Press to turn the sound OFF on the TV. Press again to return the sound to its previous level.

PIP Buttons

Press to operate Picture-In-Picture features. See PIP section for details.

Number Buttons

Press the number buttons to select TV channels. Press two number buttons to select single digit channels. For example: to select channel 6...press "0" first and then "6".

TV-VCR-CBL System Buttons

Press to send remote control commands to either the TV, VCRs, or accessory Cable Converters. See the "How to operate VCRs and Cable Converters" section for further details.

IMPORTANT REMINDER NOTE

The remote's TV-VCR-CBL System buttons control how certain buttons on the remote are used.

For example:

With the "TV" System button pressed: the MENU, (M)▲▼, and (+,-) buttons are used to select and adjust on-screen TV features.

With the "VCR" System button pressed: the same buttons on the remote work playback, search, pause, and other VCR features.

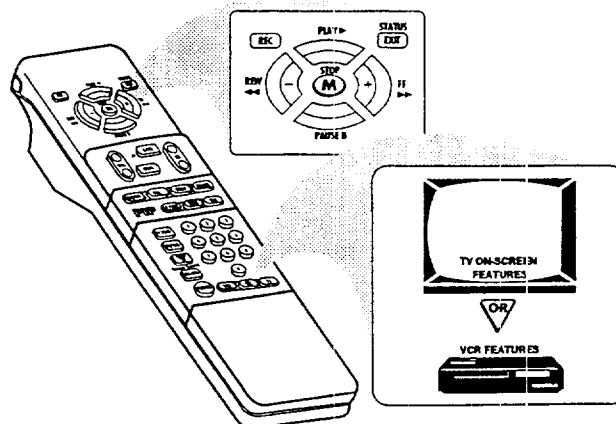



When using the TV remote with a VCR, first make certain it is set to control your VCR (by the REMOTE CODE or SEARCH method - see following section).

1 Press the VCR System button on the remote.

2 Point the top of the remote toward the front of the VCR (remote sensor window) when pressing buttons.

Record Button

Hold the RECORD button down, and then press the PLAY button to begin a VCR recording.

Rewind Button

Press to rewind tapes. For some VCRs you may need to press STOP button first then REWIND. In playback mode, hold button down to view picture moving rapidly in reverse.

Pause Button

Press to temporarily stop the tape during a playback or recording. Press again to release Pause.

TV-VCR Button

Press to the VCR position ("VCR" indicator on the VCR will light) to view the playback of a tape. Press again to place in the TV position ("VCR" indicator on the VCR will go OFF) to view one program while recording another program.

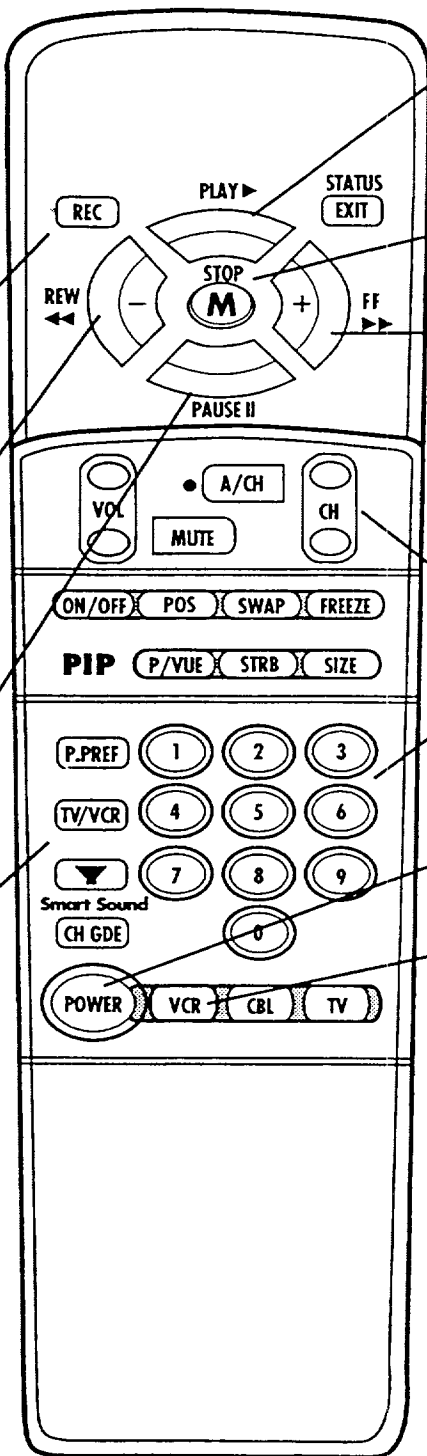

Play Button

Press to playback a tape. Hold down after pressing the RECORD button to start a recording.

Stop Button

Press to stop the tape.

Fast Forward Button

Press to rapidly advance the tape. For some VCRs you may need to press STOP first then FF. In Playback mode hold button down to view the picture moving rapidly in the forward direction.

Channel Scan Buttons

Press to scan up or down through VCR channel numbers.

Number Buttons

Press buttons for direct VCR channel selections.

Power Button

Press to turn the VCR ON and OFF.

VCR System Button

Press to send remote commands to the VCR.

 Remember. The VCR buttons on the remote will not operate your VCR if those features are not already found on your VCR remote control.

Note: All VCR functions (particularly Search, Rewind, Fast Forward, etc.) will operate the same as with the original VCR remote control provided with the VCR.

SMART SOUND AUTO VOLUME

Are you tired of hearing commercials blaring at you even when you've gone into the kitchen or down the hall? The Smart Sound (Auto Volume) control enables you to hear a more consistent, even sound level by reducing the peaks and valleys that can occur during program changes or commercial breaks.

BEGIN

- 1 Press the Smart Sound button on the remote.
- 2 Keep pressing the Smart Sound button to turn the volume level control ON (or OFF.)
- 3 Press the STATUS button to clear the screen.



Remember. Smart Sound works only with the programs coming through the Antenna/Cable input on the rear of the TV. It will not control the sound levels for the Auxiliary (VCR/AUX IN) audio inputs.

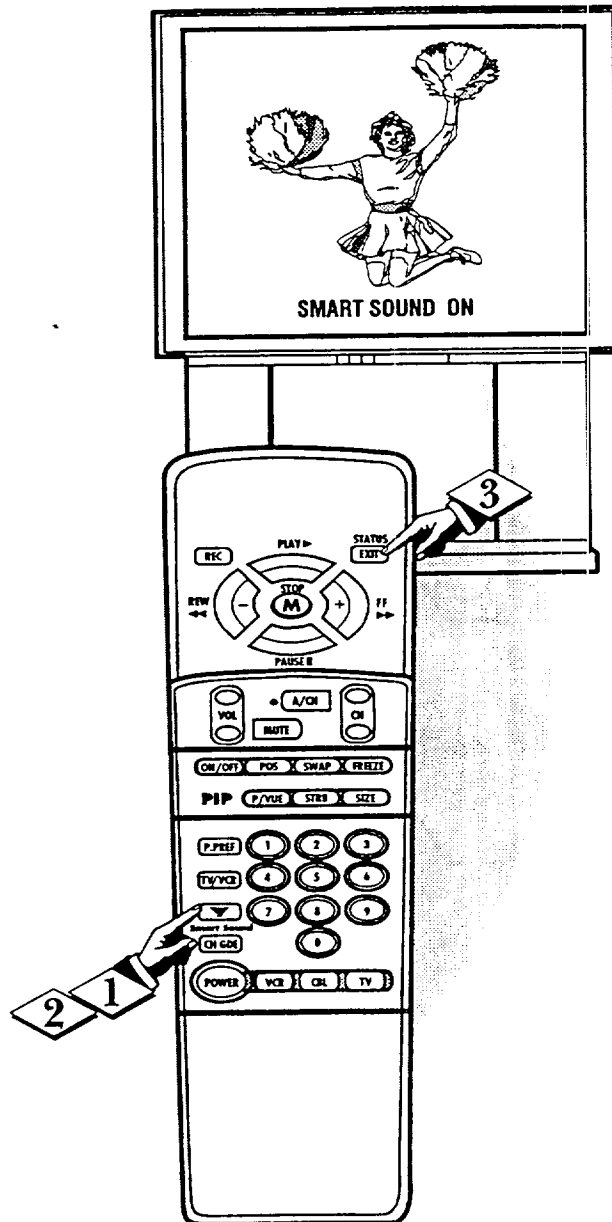

CHANNEL GUIDE

Do you ever have trouble remembering on which channel a particular station or network is located? The Channel Guide is a quick way to view and select channels from a list of Labelled channels.

A Label is a four letter callout you can set to appear with the on screen channel number. Example Label: WXYZ - for a TV station's call letters.

To select channels from the Channel Guide:

BEGIN

- 1 Press the CH GUIDE button on the remote.

A "CHANNEL GUIDE" shows on the screen with channel numbers and labels.

Keep pressing the CH GUIDE button to see what other labelled channels can be selected.

- 2 Press the number buttons on the remote to select the desired labelled channel.

Remember to press "0" first and then the number for single digit channels.

- 3 Press the MENU button to pick a Label for a channel from the "LABEL CHOICE" list, or write a new label for a channel. (See sidebar notes).

- 4 Press the STATUS button to clear the screen.

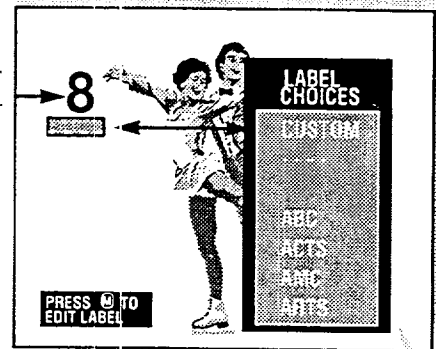
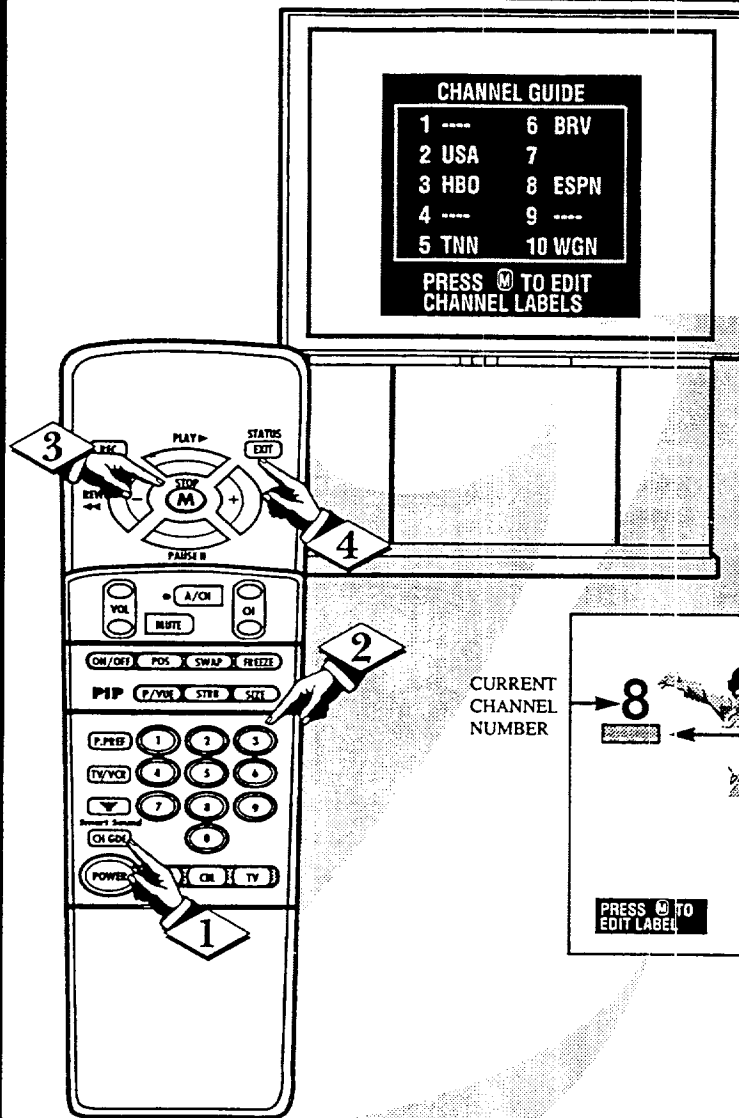

To write your own Label for a Channel:

With the double arrow pointing to "CUSTOM", press the MENU button.

8
WXYZ

A red arrow appears under the first letter space for the channel label.

Press the MENU ▲▼ buttons to pick any of the letters or symbols that are given for your use.

Press the (+) or (-) buttons to move the red arrow to the other letter spaces and repeat.

Press the STATUS button to clear the screen when finished.

To pick a Label from the "LABEL CHOICE" list:

Press the MENU ▲▼ buttons to move the red arrow through the Label Choice list.

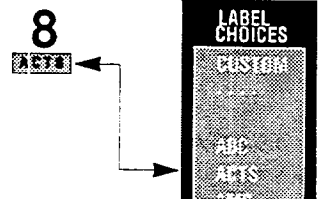

Just stop the arrow on any label you might want to use. The selected label automatically moves under the current channel number.

You can also pick a "blank" space (located above the ABC label) if you don't want any label to appear with the channel.

PERSONAL PREFERENCE

The Personal Preference button on the remote instantly returns the TV to preset channel, picture, and sound level settings you place in the TV's memory.

Five different Personal Preferences can be set so that more than one person can preset the TV for his (or her) preference.

To set Personal Preference:

BEGIN

- 1 Press the Personal Preference (P.PREF.) button on the remote.

"PERSONAL PREFERENCES" shows on the TV screen.

- 2 Press the MENU button to EDIT or setup P. PREF. for your own settings.

- 3 Press the number button on the remote for the P. PREF. you want to set. For example: press 1 for AUX IN - PREF1.

MODIFY PREF1 appears on the screen with a list of picture and sound controls.

- 4 Press the MENU ▲▼ buttons to move the red arrow up and down the list of controls. Press the MENU button to select the control.

Adjust any of the listed controls to the settings you would prefer for level PREF1.

If you want to setup P. PREF. to select a certain channel number for you, use the Picture Source Select control to set the channel.

- 5 After all control settings are finished, press the STATUS button to clear the screen.



continue to next page

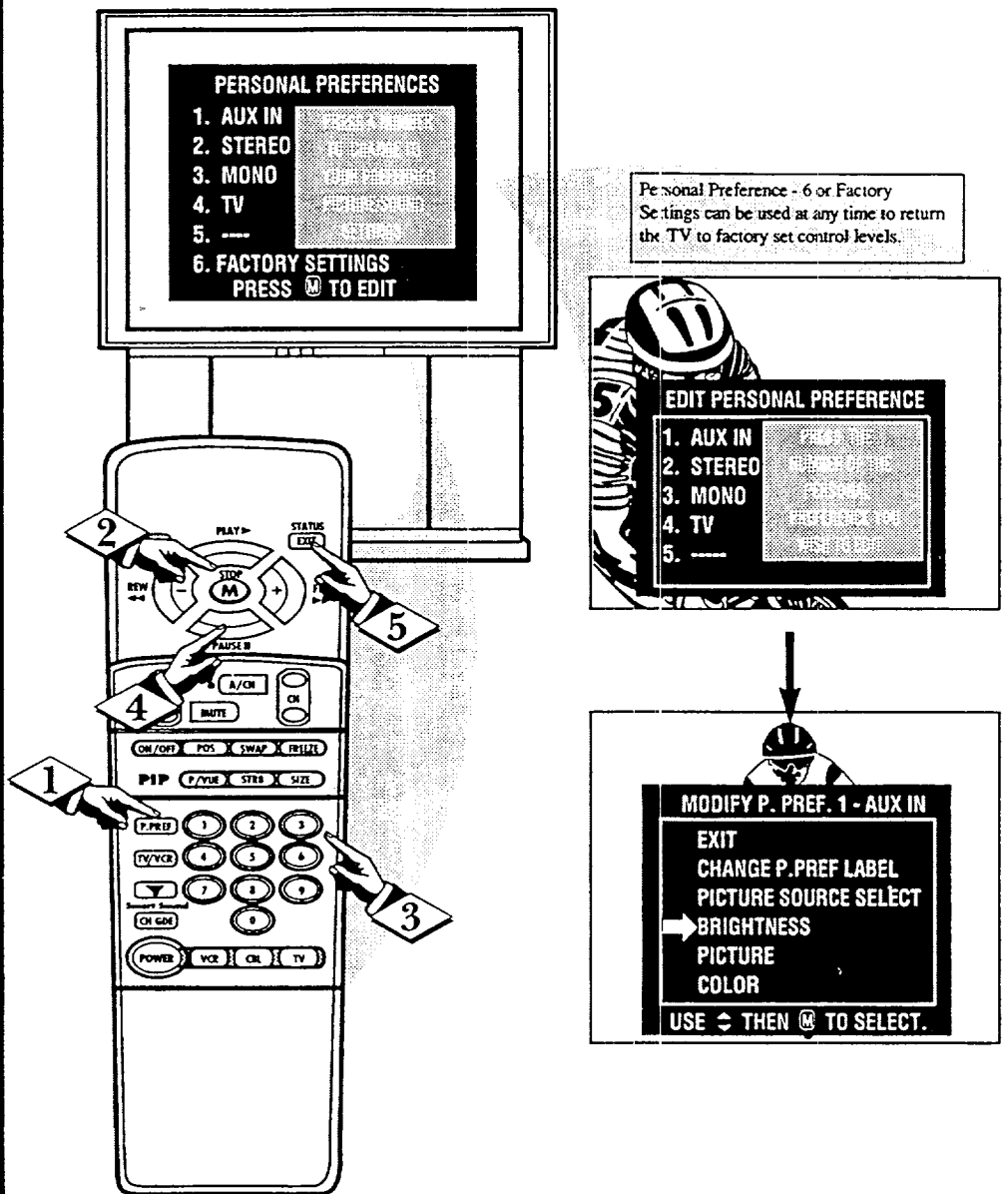

P PREF (CONTINUED)

To use the Personal Preference settings you placed in memory:

BEGIN

- 1 Press the **P. PREF** button on the remote.

"PERSONAL PREFERENCES" shows on the TV screen.

- 2 Press the number button on the remote to select the P. PREF. you desire. For example: press 1 to select "AUX IN".

The channel, picture and sound settings will change to the levels you setup for that P. PREF.



Remember. If no settings have been made for the selected P. PREF., the TV screen will show "PREFERENCE NEVER SAVED".

The "CHANGE P. PREF. LABEL" control can be used to change the title of a P. PREF. into a name or label that may be easier for you to remember.

BEGIN

- 1 With the CHANGE P. PREF. LABEL control on the screen, press the **MENU** ▲▼ buttons to spell out a new label or title for the selected P. PREF.

- 2 Press the **(+)** and **(-)** buttons to move the red arrow under each letter space.

- 3 Press the **STATUS** button to clear the screen when the new label is finished.

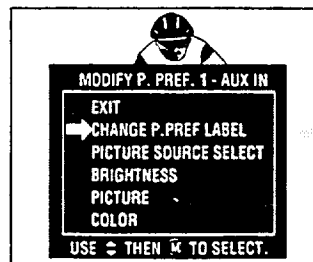
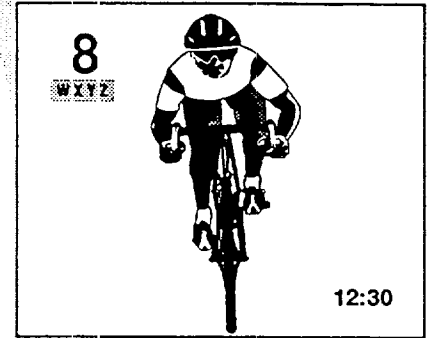
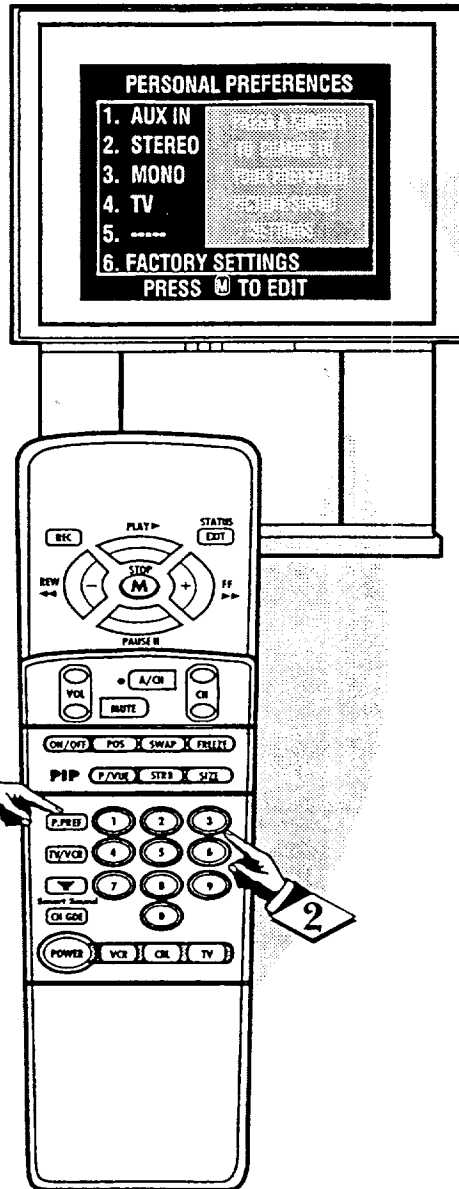

SETTING THE REMOTE TO WORK VCRs

Your remote control is set to work your TV and many infrared remote (IR) control VCRs. However, an easy one-time step may be necessary before the remote will work your VCR.

Try this initial check to see if going on to the following section is necessary.

BEGIN

- 1 Press the VCR System button on the remote.
- 2 Point remote toward VCR and press the POWER button.
- 3 Does the remote turn the VCR ON?
IF YES, and try the other VCR buttons on the remote. If they also work the VCR, then the remote is ready and no further steps are needed.
IF NO, continue...

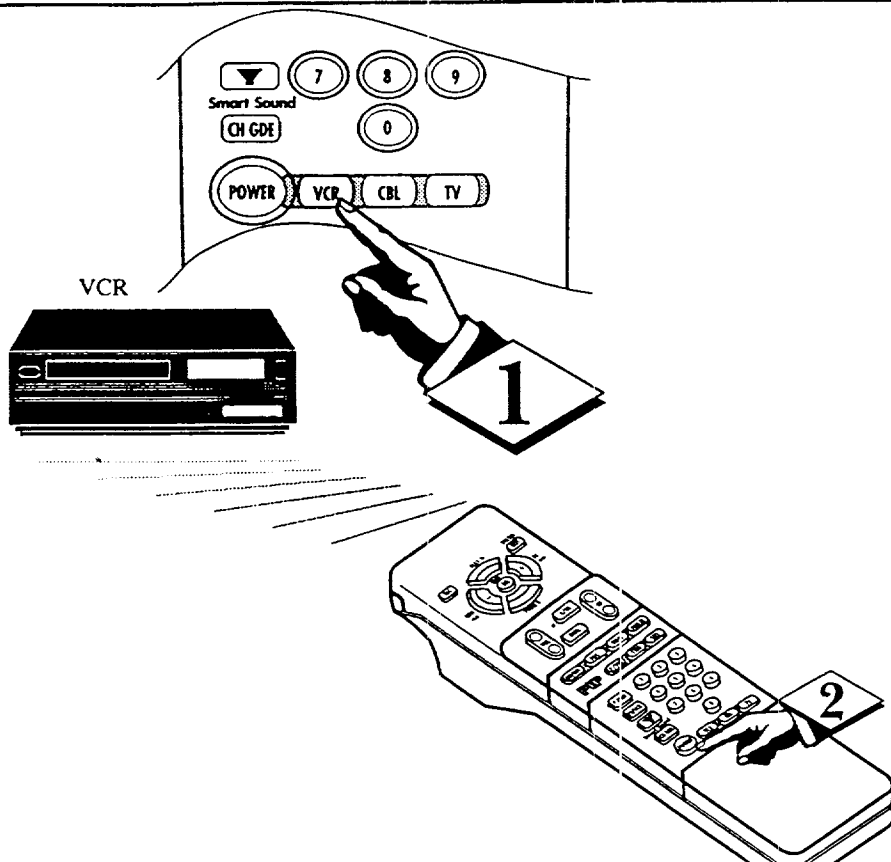

- 1 First look up a **TWO-DIGIT remote code number** for your brand VCR before going through the simple "1,2,3" steps (on the following page).

Remember. If more than one number is listed, you may have to try more than the first two-digit code given in order to locate your VCR's remote code.

continue to next page

VCR BRAND	REMOTE CODE NO.	VCR BRAND	REMOTE CODE NO.
Akai	24, 25, 36	Multitech	27, 28
Audio Dynamics	14, 21, 29	NEC	14, 21, 29
Broksonic	31	Panasonic	01
Cannon	01	Pen:ax	02, 03
Capehart	33	Philco	01, 02, 05, 27, 28
Craig	07, 30	Philips	00, 01, 02, 05, 27, 28
Curtis Mathes	01, 32, 42, 43	Quasar	01
Daewoo	33	RCA	03, 04, 32, 42, 43, 44
DBX	14, 21, 29	Realistic	07, 11, 12, 23, 27, 28
Dynatech	27	Samsung	22, 30
Emerson	20, 31, 34, 40	Sansui	49
Fisher	06, 07, 08	Sanyo	07, 13
Funai	27, 28	Scott	19
GE	01	Sears	03, 08, 23
Goldstar	23	Sharp	11, 12
Go Video	45, 46	Shinton	35
Hitachi	03, 51	Sony	09, 10, 41
Instant Replay	01	Sound Design	27
JC Penney	01, 03, 23, 29	Sylvania	00, 01, 02, 05, 27, 28
JVC	14, 47, 48	Symphonic	27
Kenwood	13, 14	Tating	14
Lloyds	27	Teac	14, 27
Magnavox	00, 01, 02, 05, 27, 28	Teknika	26, 27
Magnin	30	Thcmas	27
Marantz	29	TMK	20
Memorex	01, 07, 23, 27	Toshiba	18, 19
Minolta	03	Video Concepts	28, 29
Mitsubishi	16, 17, 38, 39, 50	Yamaha	14, 28, 29
Montgomery Ward	12	Zer:ith	15

Now that you have looked up the two-digit Remote Code Number for your brand of VCR (on previous page), you are ready to follow the four simple steps below.

Please read through steps 1-4 before beginning.

BEGIN

- 1 Press and release the REC (RECORD) button.
- 2 Within thirty seconds after releasing the REC button, press and release the VCR System button.
- 3 Within thirty seconds after releasing the VCR System button, ENTER THE TWO DIGIT CODE NUMBER for the desired VCR. The remote is now ready to send commands to the VCR.
- 4 Point the remote at the VCR. Press the POWER button on the remote to turn the VCR ON.



Try it out. The Channel and VCR buttons on the remote should now operate the VCR.

Remember. If this doesn't work the first time, repeat steps using the same remote code number.

If after a second try the remote does not operate your VCR, and there are more code numbers listed for your brand VCR, use the next listed code number.

If after repeated attempts the code number method does not work your VCR, try the "VCR SEARCH" method on page 48.

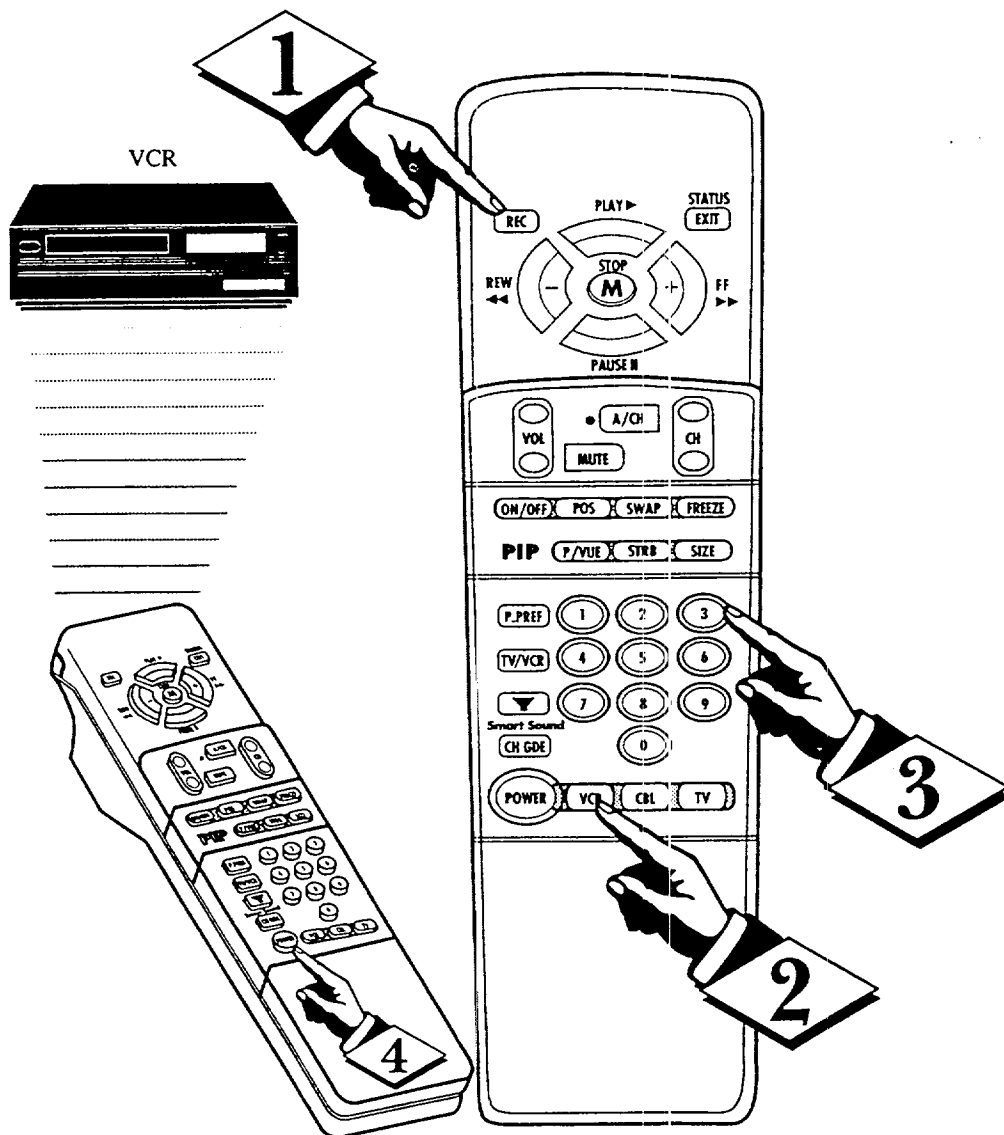



SETTING THE REMOTE TO WORK CABLE TV CONVERTERS

Your remote control is set to work your TV and many infrared remote (IR) control Cable Converters. However, an easy one-time step may be necessary before the remote will work your Converter.

Try this initial check to see if going on to the following section is necessary.

BEGIN

- 1 Press the CBL System button on the remote.
- 2 Point remote toward Cable Converter and press the POWER button.
- 3 Does the remote turn the Converter ON?
 IF YES,  and try the CH   and CH number buttons on the remote. If they also work the Converter then the remote is ready and no further steps are needed.
 If NO, continue...

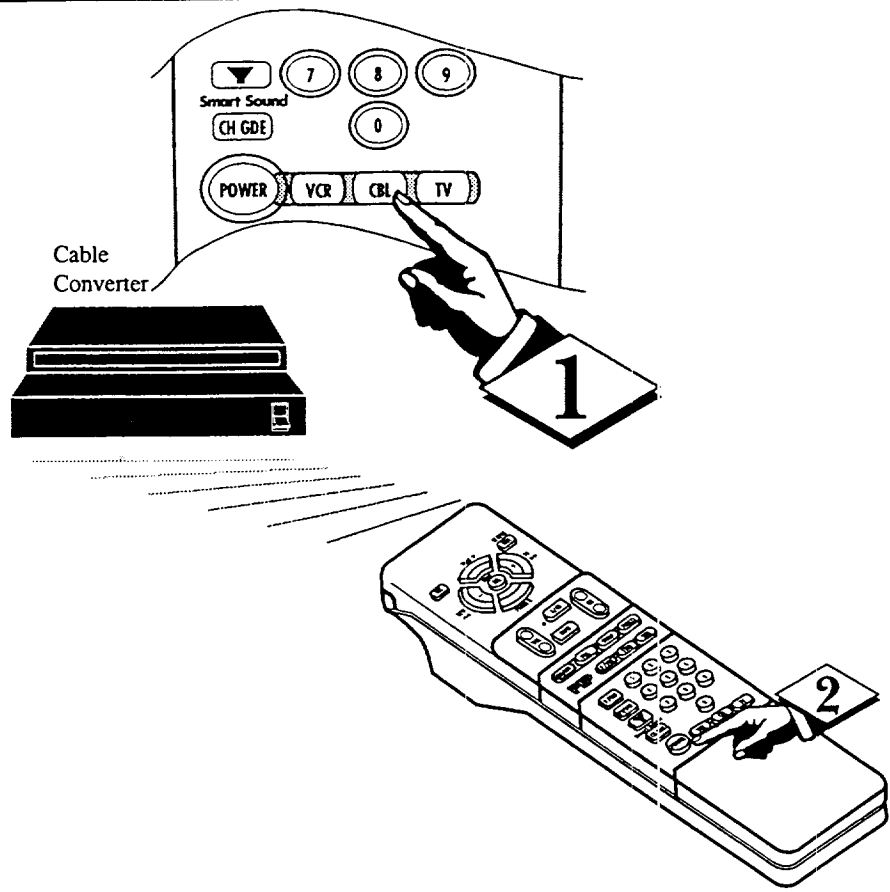

- 1 First look up a **TWO-DIGIT remote code number** for your brand Converter before going through the simple "1,2,3" steps (on the following page).

 Remember. If more than one number is listed, you may have to try more than the first two-digit code given in order to locate your Converter's remote code.

continue to next page

<u>CONVERTER BRAND</u>	<u>REMOTE CODE NO.</u>	<u>CONVERTER BRAND</u>	<u>REMOTE CODE NO.</u>
Archer	28	Rembrant	33
Diamond	23	Salora	52
Drake	37	Scientific Atlanta	08, 22, 47
Gemini	45	Sheritech	34
Hamlin	14, 15	Sylvania	16
Hitachi	25	Texscan	16, 48
Jerrold	01,02,03,04,05,30,46	Tocom	12,13, 53
Macom	29, 38	Toshiba	43
Magnavox	17,26, 31	Uniden Satellite	44, 54
NSC	49	Unika	50
Oak	06, 27, 39	Universal	36
Panasonic	18, 35	Video Tech	40
Philips	19, 20, 21, 24, 26	Video Way	51
Pioneer	09, 32	Viewstar	26
Regency	10, 11	Zenith	07, 41, 42

Now that you have looked up the two-digit Remote Code Number for your brand of Cable Converter (on previous page), you are ready to follow the four simple steps below.

Please read through steps 1-4 before beginning.

BEGIN

- 1 Press and release the REC (RECORD) button.
- 2 Within thirty seconds after releasing the REC button, press and release the CBL System button.
- 3 Within thirty seconds after releasing the CBL System button, ENTER THE TWO DIGIT CODE NUMBER for the desired Converter. The remote is now ready to send commands to the Converter.
- 4 Point the remote at the Converter. Press the POWER button on the remote to turn the Converter ON.



Try it out. The Channel and POWER buttons on the remote should now operate the Converter.

Remember. If this doesn't work the first time, repeat steps using the same remote code number.

If after a second try the remote does not operate your Converter, and there are more code numbers listed for your brand Converter, use the next listed code number.

If after repeated attempts the code number method does not work your Converter, try the "CONVERTER SEARCH" method on page 49.

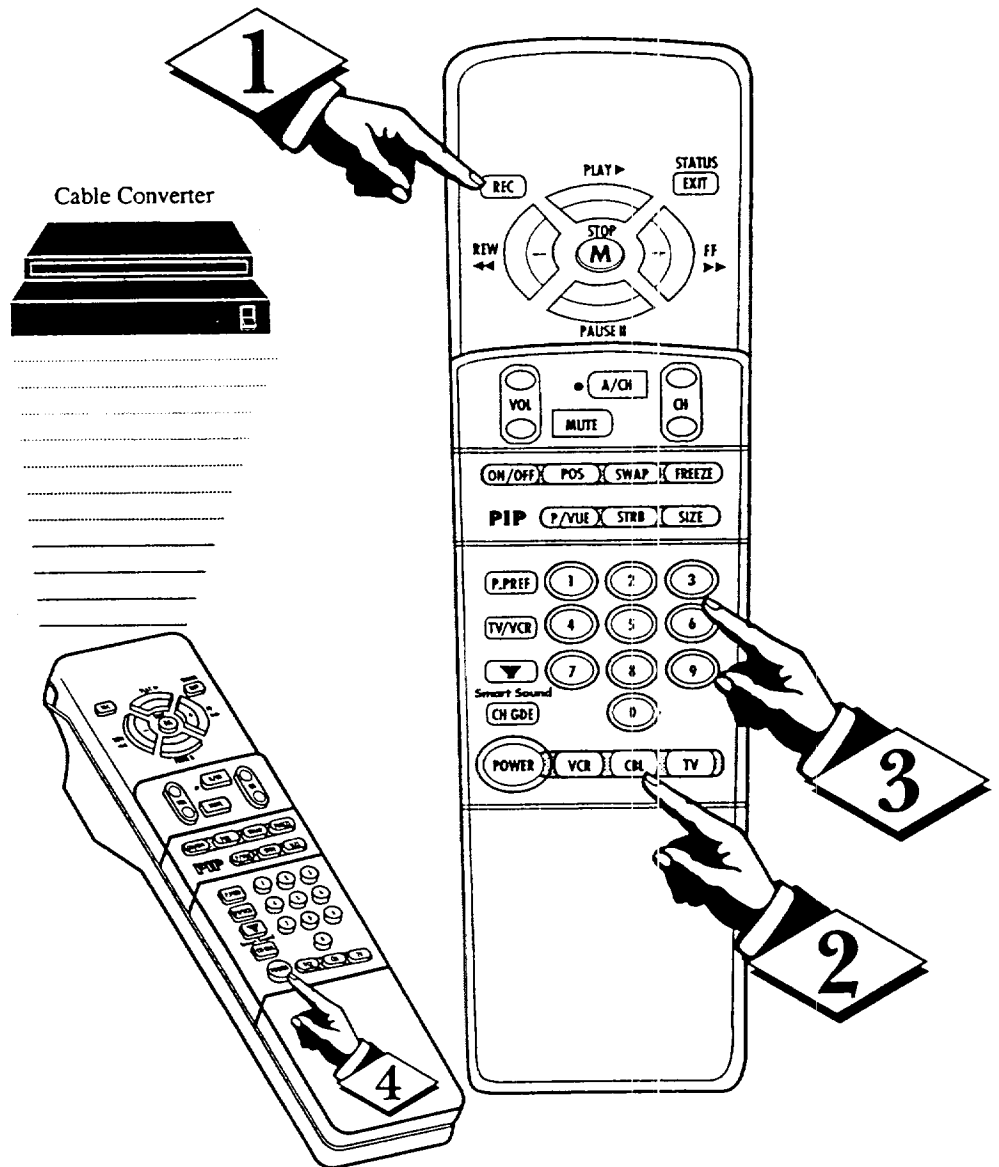

Your TV remote can be set to work your VCR by what is called the SEARCH method.

If the "REMOTE CODE" number method shown in the previous section did not set your remote to work your VCR, then follow the five easy steps listed below.

Please read through steps 1-5 before beginning.

BEGIN

- 1 Press the **POWER** button on the VCR to turn VCR ON.
- 2 Stand at least six feet away from the front of the VCR. Point the remote toward the VCR. **HOLD DOWN** the **A/CH** and **VCR System** buttons at the same time. **KEEP HOLDING** **BUTTONS DOWN**.
- 3 Watch the **Channel Indicator** on the VCR. Channel Numbers will **SCAN UP** when the VCR has been identified. This may take up to two minutes.
- 4 Release the **A/CH** and **VCR System** buttons as soon as channel numbers start to scan up. The VCR code has been identified and the remote is ready to operate the VCR.



Remember. A minute or two can seem very long, but the code should be located within two minutes.

Don't let the VCR scan up more than five channels. If you do the remote may pass up the right code and another two minute search cycle will have to be repeated.

If no channel change happens within two minutes, repeat steps 1-5. Should a channel change still not occur, the remote will not work with the desired VCR.

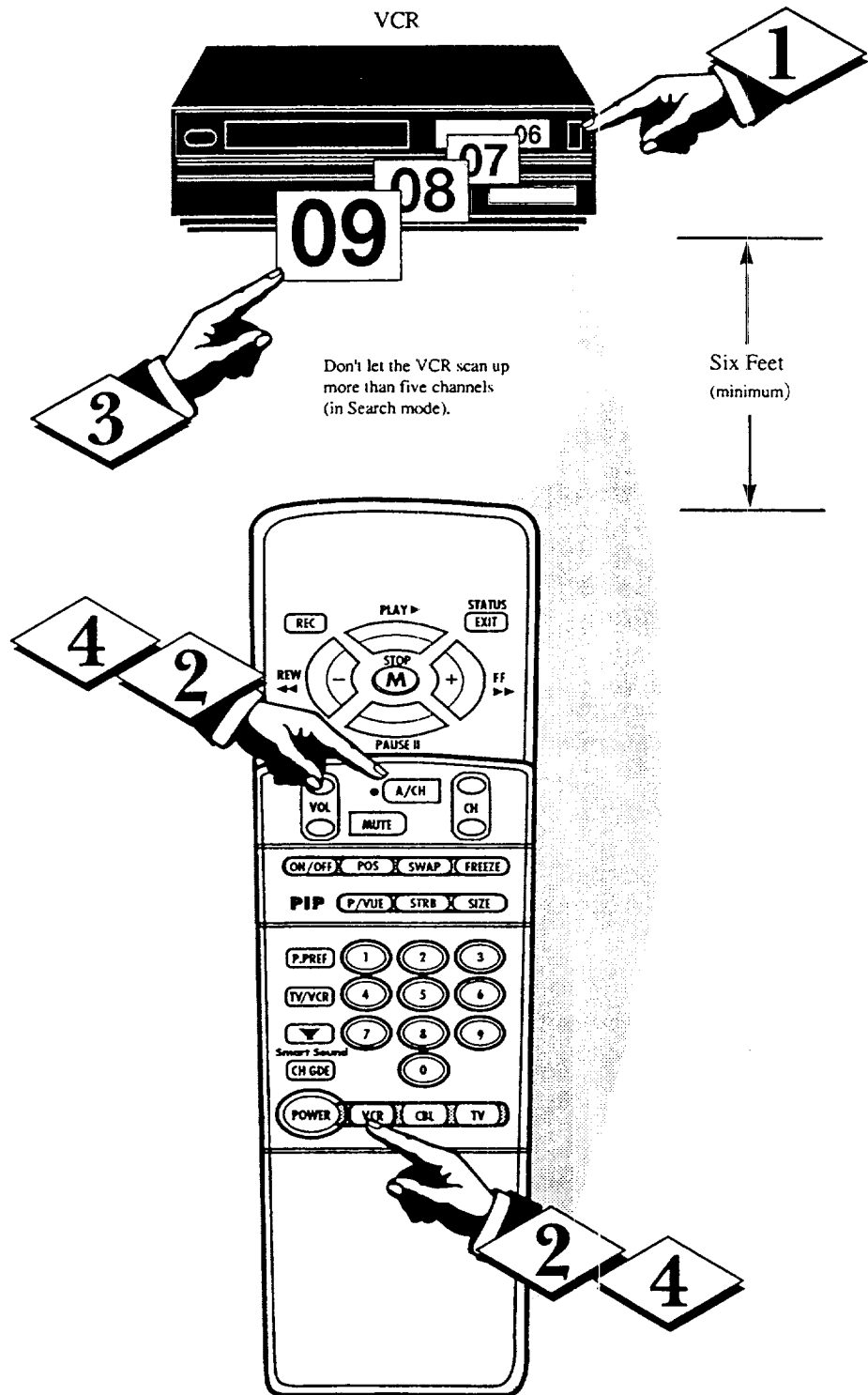



Your TV remote can be set to work your Cable Converter by what is called the SEARCH method.

If the "REMOTE CODE" number method shown in the previous section did not set your remote to work your Converter, then follow the five easy steps listed below.

Please read through steps 1-5 before beginning.

BEGIN

- 1 Press the **POWER** button on the Converter to turn Converter ON.
- 2 Stand at least six feet away from the front of the Converter. Point the remote toward the Converter. **HOLD DOWN** the **A/CH** and **CBL System** buttons at the same time. **KEEP HOLDING** **BUTTONS DOWN**.
- 3 Watch the **Channel Indicator** on the Converter. Channel Numbers will **SCAN UP** when the Converter has been identified. This may take up to two minutes.
- 4 Release the **A/CH** and **CBL System** buttons as soon as channel numbers start to scan up. The Converter code has been identified and the remote is ready to operate the Converter.



Remember. A minute or two can seem very long, but the code should be located within two minutes.

Don't let the Converter scan up more than five channels. If you do the remote may pass up the right code and another two minute search cycle will have to be repeated.

If no channel change happens within two minutes, repeat steps 1-5. Should a channel change still not occur, the remote will not work with the desired Converter.

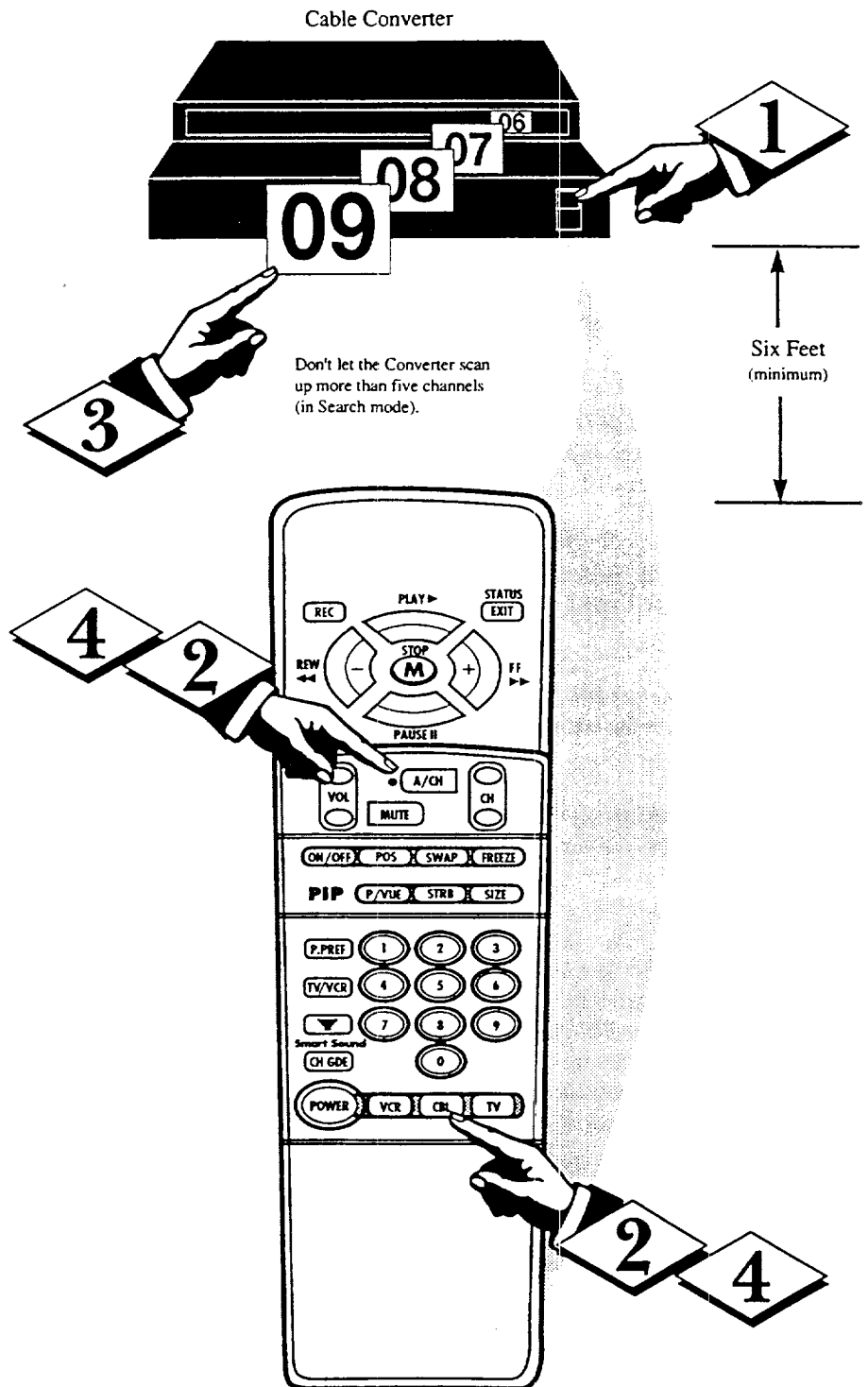

HOW TO USE THE PICTURE-IN-PICTURE (PIP) FEATURE

Picture in Picture (PIP) is the showing of two pictures on the TV screen at the same time. (One main screen picture and one small inset picture - or PIP).

Note: The PIP picture must be supplied by a VCR (or other accessory equipped with a VIDEO OUTPUT jack). If you already went through FIRST TIME SETUP (page 10), then the connections for PIP have been completed.

To see how channels selected on a VCR can be shown as PIP:

BEGIN

- 1 Connect the VIDEO OUT jack on the VCR to the AUX IN1 VIDEO IN jack on the TV.

Also connect the AUDIO OUT (R and L) jacks from the VCR to the AUX IN1 AUDIO IN jacks on the TV.

Also ensure the normal antenna connection between the VCR and TV are in place.

- 2 Move to the next page after the VCR to TV PIP connections are completed.

 Remember. The AUX IN1 or AUX IN2 jacks can be used for PIP connections. Please be sure that the PIP Picture Source control (page 54) is set for the correct set of Audio/Video Inputs that are being used.

No sound will be heard with the PIP picture. See page 52 on how to "SWAP" the PIP picture with the main screen picture so that sound can be heard.

If you have a single (monaural) Audio Output VCR, "Y" connectors are available to complete your connection. Contact your dealer, or our Parts Information Center, for details.

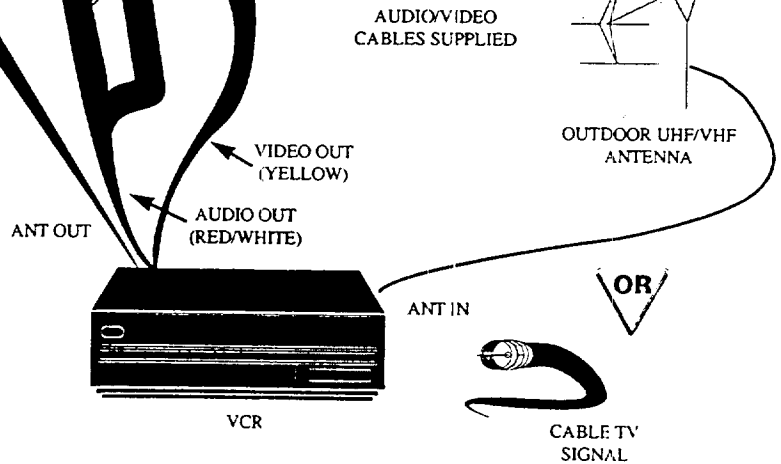
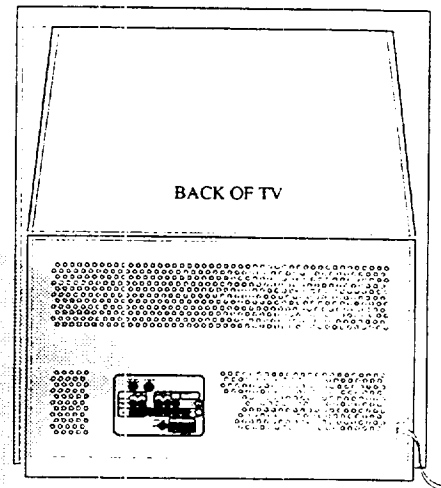
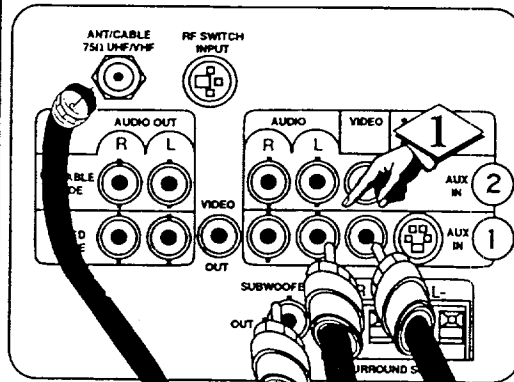
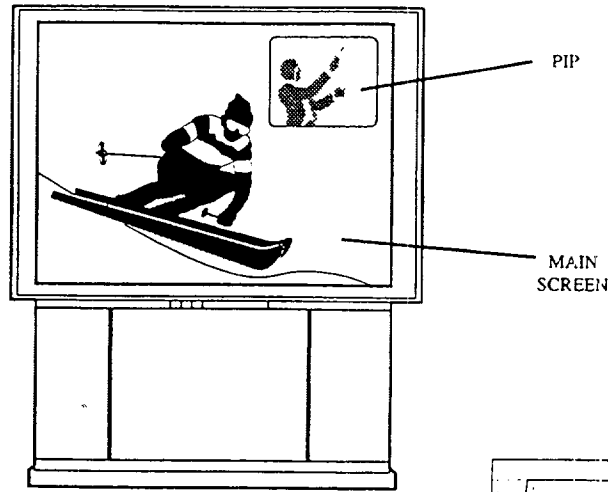

Now that you have completed the required connections on the previous page you are ready to follow the simple steps shown below.

3 Turn the VCR and TV ON.

Place the VCR in the TV mode - Use the TV/VCR button on the TV remote (if the remote has been set to work with your VCR - see page 44.)

Place the TV in the ANT/CABLE mode -

Use the MENU (and M ▲▼) buttons on the remote to set MAIN PICTURE SOURCE control to ANT/CABLE.

4 Select the channels on the TV and VCR to be watched.

5 Press the PIP ON/OFF button on the remote.



Remember. See the following page on how to operate other PIP features with the remote control.

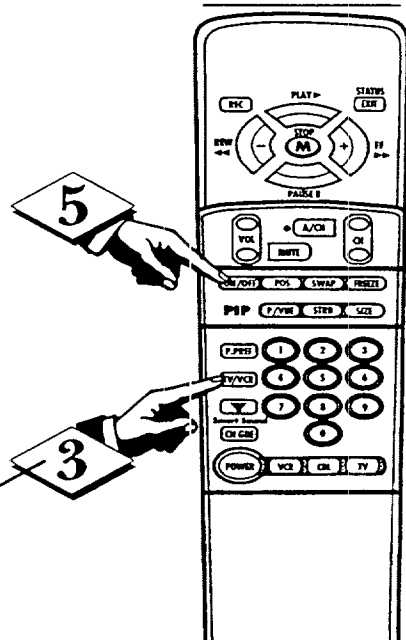
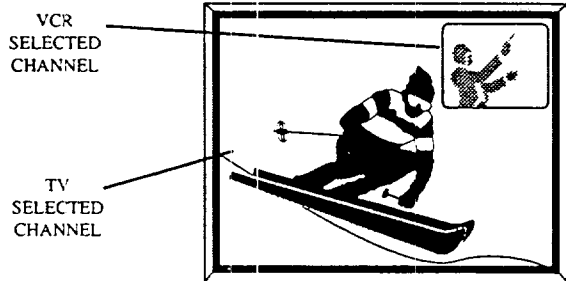
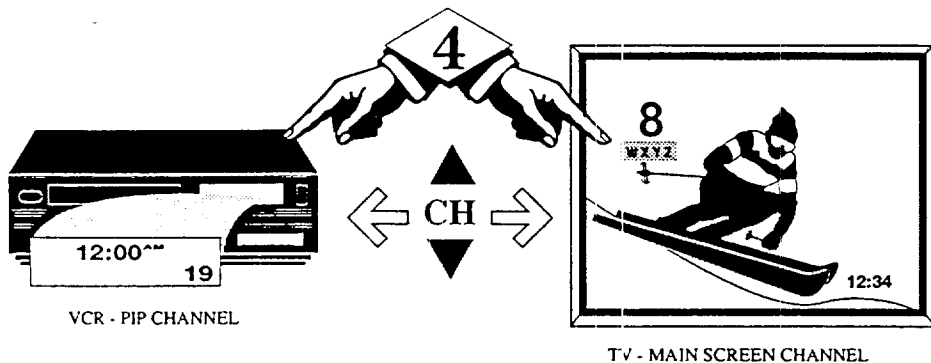
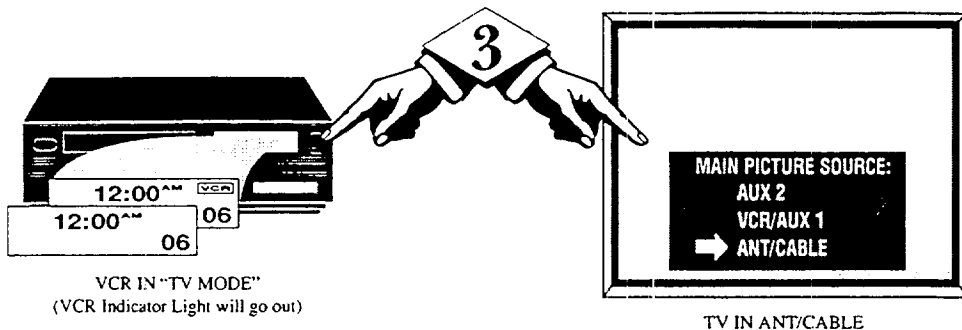

Be sure to point the remote at the front of the VCR when pressing VCR function buttons.

By using the PIP buttons on the remote the PIP picture can be moved and swapped with the main screen.

BEGIN

- 1 Press **PIP ON** button to show the PIP picture.
PIP screen appears in corner of TV screen. Press PIP ON again to remove PIP from the main screen.
- 2 Press **PIP POSITION** button on the remote to move the PIP picture (from corner to corner on the main screen).
- 3 Press **SWAP** to swap the main screen picture with the PIP picture.
Press SWAP again to return the main screen and PIP to their original positions. See the important reminder below.
- 4 Press **FREEZE** button to hold the current Main picture in the PIP window (Main picture is active).
If PIP is currently OFF the PIP will be automatically shown.
Press FRZ repeatedly to update the frozen PIP with current pictures. The frozen PIP cannot be swapped with the main screen.
Press the PIP ON/OFF button to drop the frozen PIP picture from the screen.

continue to next page

 Remember. If the PIP picture is on the main screen when the TV is turned OFF, a blank screen will appear when the TV is turned back ON again.

If this happens, you can either:

Press the **CHANNEL ▲** or **▼** buttons to select a channel for viewing (if the AUX1 or AUX2 mode has been added to TV's channel memory - see page 29).



Use the Picture Source Select control (see page 16) to return the TV to the ANT/CABLE mode.

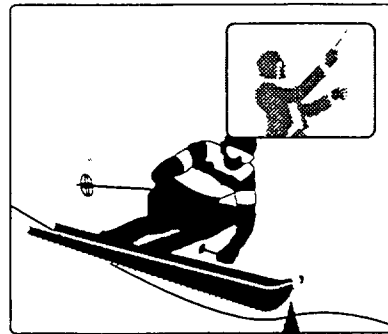

3. PIP SWAP

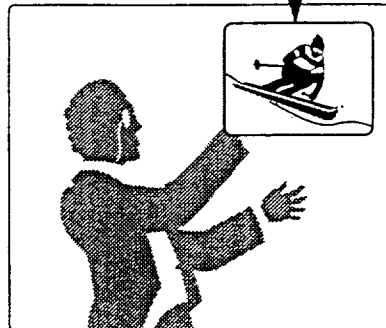

2. PIP POSITION

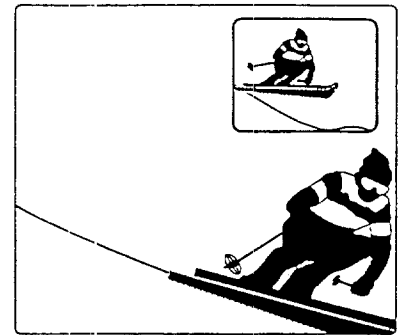
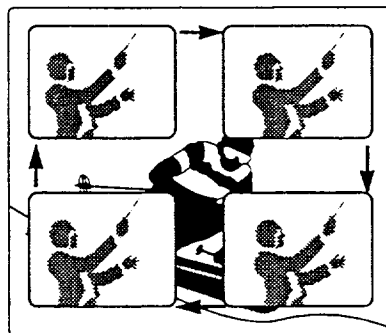

4. FREEZE

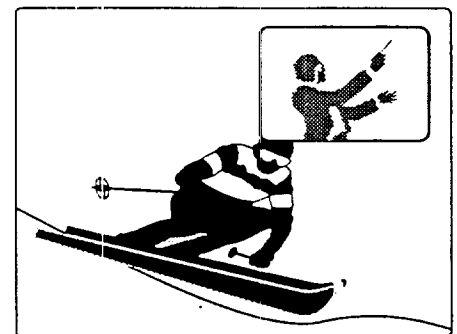

1. PIP ON / OFF

5. PIP SIZE



6. PIP STROBE

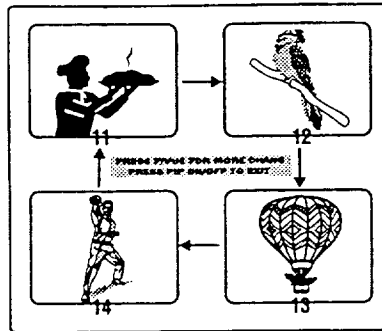
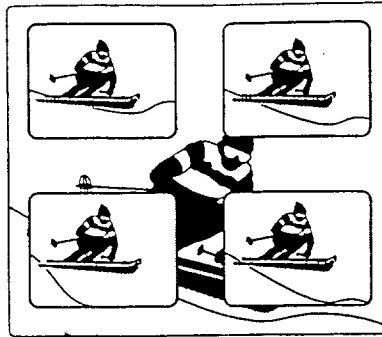

7. PIP PREVIEW

REMOTE WITH PIP (CONTINUED)

5 Press **SIZE** button to change the size of the PIP window shown on the TV screen.

Press the PIP SIZE button again to see and compare the large and small size PIP windows.

6 Press **STROBE** to see a series of four frozen scenes from the currently selected channel. Press **STROBE** again and the series of pictures will be updated.

7 Press **PREVIEW** button to see what is showing on four channels. P/VUE starts with the current channel and shows the next three channels in memory.

Every few seconds each P/VUE picture will be updated with a current scene for that channel.

Press P/VUE again to go to the next four channels in memory and so on. Just press the number buttons to select any previewed channel.

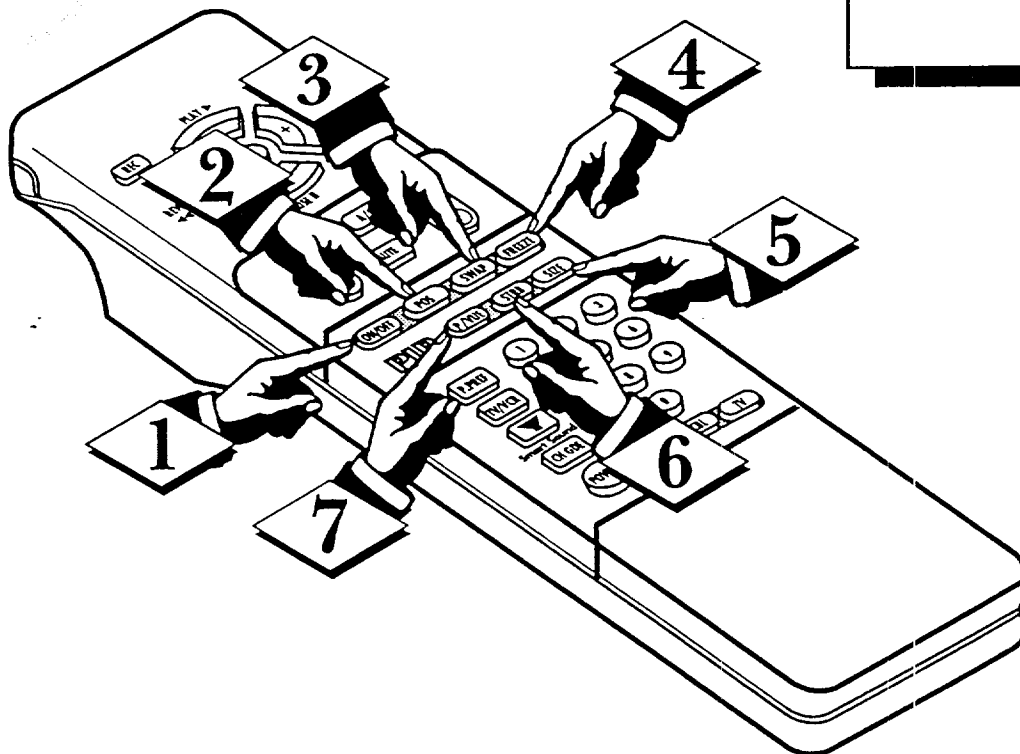

PIP PICTURE SOURCE

The picture for the PIP window can come through either the ANT/CABLE, VCR/AUX1 or AUX IN2 Inputs (on the rear of the TV). PIP Picture Source simply tells the TV which one of these three sources it is to show in the PIP.

BEGIN

- 1 Select PIP PICTURE SOURCE control.

With the ADVANCED CONTROLS on screen, move the red arrow with the MENU ▲▼ buttons. Then press MENU button.

- 2 Press the MENU ▲▼ buttons to select the source for the PIP picture as either:

VCR/AUX1- for a picture signal coming from the AUX IN1 Audio/Video jacks on the TV.

AUX2- for a picture signal coming from the AUX IN2 Audio/Video jacks on the TV.

ANT/CABLE- for a picture signal coming from the ANT/CABLE Input on the TV.

- 3 Press the STATUS button to clear the screen.



Remember. The PIP screen will be blank unless a signal is connected to the selected source (either ANT/CABLE, VCR/AUX1 or AUX2 Inputs) on the rear of the TV.

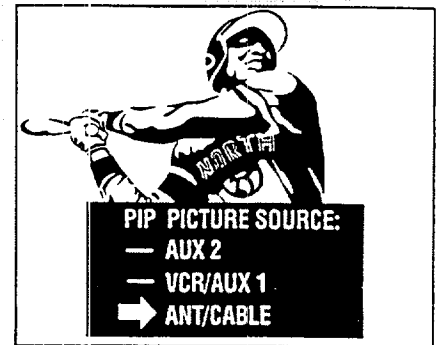
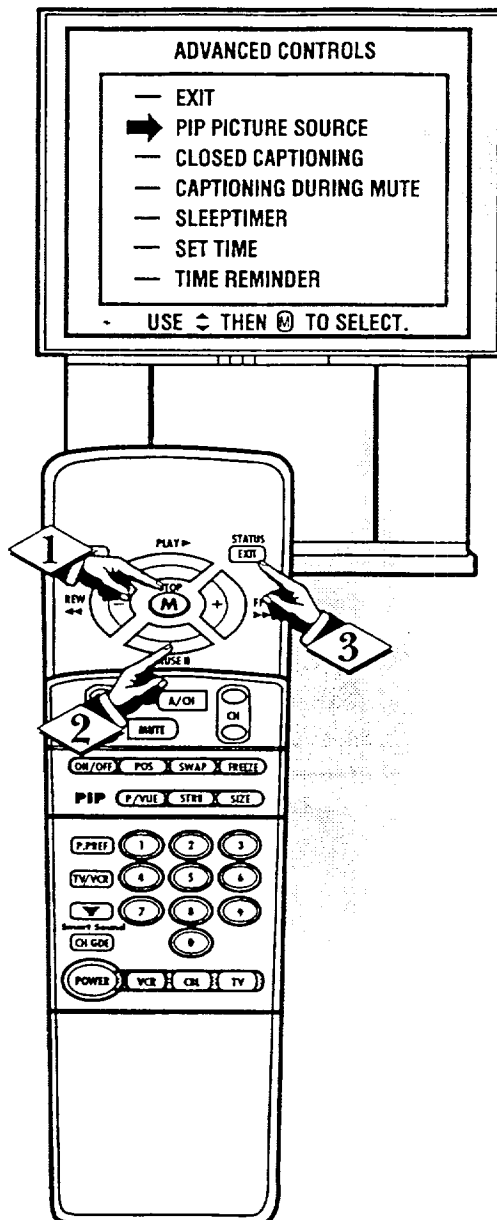

PIP COLOR / PIP TINT

The Picture-In-Picture (PIP) Color and Tint controls are used to adjust the color settings for PIP when it is shown on the TV screen.

BEGIN

- 1 Select PIP COLOR (or TINT) control.

With the PICTURE/SOUND CONTROLS on screen, move the red arrow with the MENU ▲▼ buttons. Then press MENU button.

- 2 The PIP automatically comes on to show the PIP window on the TV screen.

If you used the First Time Setup (page 10), the TV is ready to show the playback of a VCR tape in the PIP window.

If you want to see how channels selected on the VCR can be viewed in the PIP window, see pages 50-51.

- 3 Press the (+) and (-) buttons to adjust the PIP for Color (or Tint) levels you prefer.

- 4 Press the STATUS button to clear the screen.



Remember. Although there are separate COLOR and TINT controls for PIP, the adjustment levels for these controls depend on the TV's main picture. For example: If the main screen is showing a black and white picture, PIP would also be in black and white (even though its source is in color).

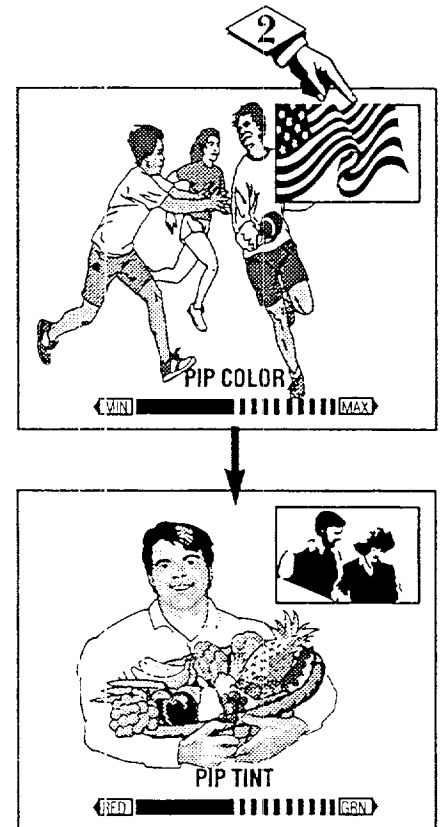
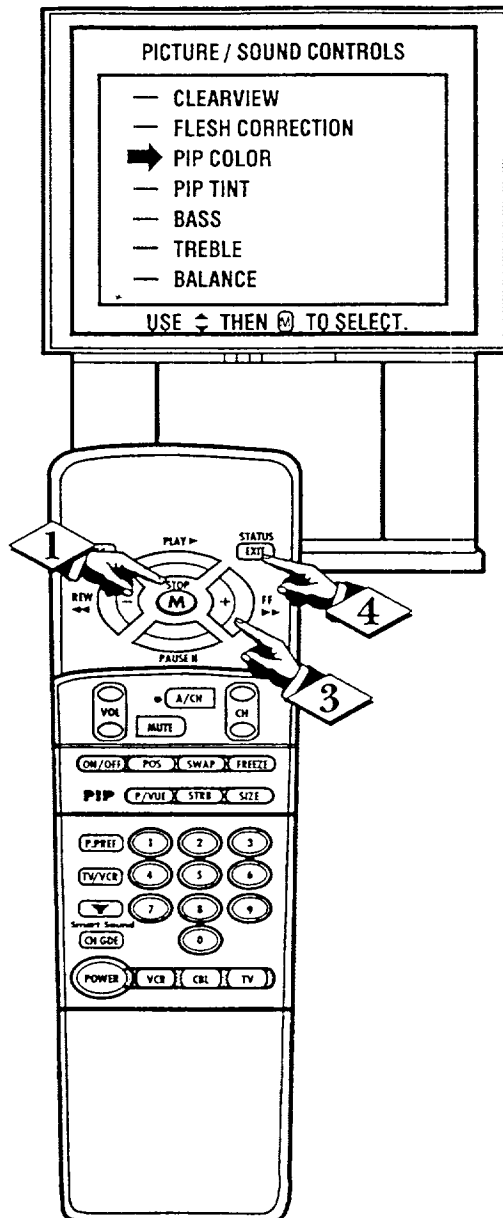

PIP hookup with Cable Converter Box and VCR.

BEGIN

- 1 First use an optional signal splitter and connect the original cable TV signal to both the CABLE IN on the Cable Converter and the ANTENNA plug on the rear of the TV.
- 2 Connect the CABLE OUT on the Converter to the ANT. IN on the VCR.
- 3 Connect the VIDEO OUT jack on the VCR to the VIDEO IN jack on the TV.

Also connect the AUDIO OUT (R and L) jacks from the VCR to the AUDIO IN jacks on the TV.



Remember to use the Cable TV Converter Box to select channels for PIP, the VCR must be set to the same channel as the channel selection switch on the rear of the Cable Converter (either channel 3 or 4).

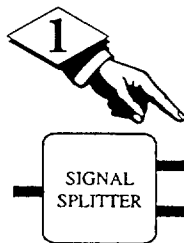

Contact the Parts Information Center
1 800 292-6066
to order any optional accessories

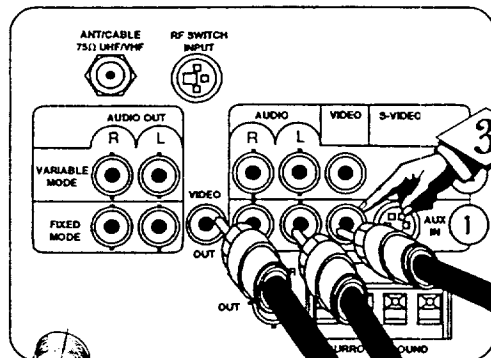

REAR OF TV

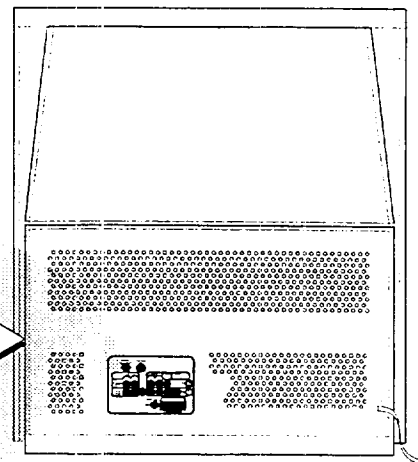

AUDIO VIDEO CABLES SUPPLIED

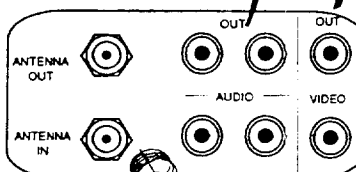

VCR

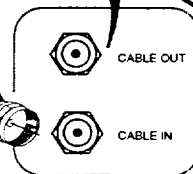
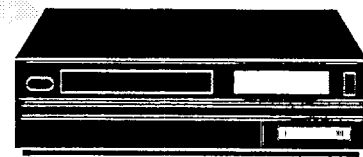

CABLE TV CONVERTER

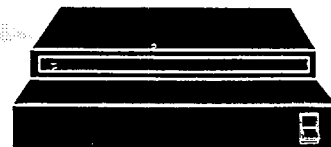



Please make these simple checks before calling for service. These tips can save you time and money since charges for TV installation and adjustment of customer controls are not covered under your warranty.

No Power

- Check the TV power cord. Unplug the TV, wait 1 minute, then reinsert plug into outlet and push POWER button again.
- Check to be sure outlet is not on a wall switch.

No Picture

- Check antenna connections on the rear of the TV. Are they properly secured to the antenna plug on the TV?
- Check the CABLE CHANNEL TUNING control for correct position.
- Check PICTURE SOURCE control for correct position. VCR/AUX1 or AUX2 position without a signal source will result in a blank screen.

No Sound

- Check the VOLUME buttons.
- Check the MUTE button on the remote control.
- Check the INTERNAL TV SPEAKER ON/OFF control for the correct position.
- If attempting auxiliary equipment hook-ups, check audio jack connections and that the auxiliary equipment is on and in the proper operating modes.

Remote Does Not Work

- Check TV-VCR-CBL "System" buttons on the remote. Press the remote's TV System button to send commands to the TV.
- Check batteries. Replace with 9-Volt Heavy Duty (Zinc Chloride) or Alkaline batteries if necessary.
- Clean the remote and the remote sensor window on the TV.

TV Displays Wrong Channel or No Channels Above 13

- Repeat channel selection.
- Add desired channel numbers (ADD/DELETE CHANNELS control) into TV memory.
- Check CABLE CHANNEL TUNING control for correct position.

**QUESTIONS ABOUT THIS PRODUCT?
CALL OUR INFORMATION CENTER.**

800-531-0039

This TV is equipped with protective circuitry that shuts the TV off in case of moderate power surges. Should this occur turn the TV back on by pressing the POWER button once or twice, or unplug and then replug the power cord at the AC outlet. This feature is NOT designed to prevent damage due to high power surges such as those caused by lightning, which is not covered by your warranty.

Cleaning and Care

- To avoid possible shock hazard be sure the TV is unplugged from the electrical outlet before cleaning.
- When cleaning the TV screen take care not to scratch or damage the screen surface (avoid wearing jewelry or using anything abrasive- do not use household cleaners). Wipe the front screen with a clean cloth dampened with water. Use even, easy, vertical strokes when cleaning.
- Specially designed screen cleaning kits are also available which contain anti-static cleaners and brushes designed to get into the ridges of the TV screen. If interested, ask your dealer about the SBS4100 Projection TV Screen Cleaning Kit or call our toll-free Accessory Parts ordering number 1-800-292-6066.
- Gently wipe the cabinet surfaces with a clean cloth or sponge dampened in a solution of cool clear water and a mild soap or detergent. Use a clean dry cloth to dry the wiped surfaces.
- Occasionally vacuum the ventilation holes or slots in the cabinet back.
- Never use thinners, insecticide sprays, or other chemicals on or near the cabinet, as they might cause permanent marring of the cabinet finish.



Coaxial Cable * A single solid antenna wire normally matched with a metal plug (F-type) end connector that screws (or pushes) directly onto a 75 Ohm input found on the Television or VCR.

Display * An on screen message or graphics that help the user operate and adjust his Television feature controls. See On Screen Displays (OSD).

Direct Audio/Video Inputs * Located on the rear of the TV these connectors (RCA phono type plug) are used for the input of audio and video signals. Designed for use with VCRs (or other accessories) in order to receive higher picture resolution and offer sound connection options.

Identify * Method by which a remote control searches and finds an operating code for another product (such as a VCR or Cable Converter.) Once the code has been "identified" then the TV remote can send commands to and operate the other product.

Multichannel Television Sound (MTS) * The broadcast standard that allows for stereo sound to be transmitted with the TV picture.

On Screen Displays (OSD) * Refers to the wording or messages generated by the television (or VCR) to help the user with specific feature controls (color adjustment, programming, etc.).

Menu * An on-screen listing of feature controls shown on the Television screen that are made available for user adjustments.

Picture -In-Picture (PIP) * Term used when two pictures are shown on the TV screen at the same time. The smaller PIP picture is supplied by a VCR (or other tuner/video playback source). The PIP picture can also be moved and swapped with the TV's main screen picture.

Programming * The procedure of adding or deleting channel numbers into the Television's memory circuits. In this way the Television "remembers" only the locally available or desired channel numbers and skips over any unwanted channel numbers.

Remote Sensor Window * A window or opening found on the Television control panel through which infrared remote control command signals are received.

Second Audio Program (SAP) * An additional audio channel provided for in the Multichannel Television Sound (MTS) broadcast standard. The most frequently proposed use for SAP is the simultaneous bilingual broadcast of TV program material.

Status * Allows the user to quickly confirm what channel number is currently being viewed. Status can also be used to clear the Television of on screen displays or information (rather than waiting for the displays to "time out" or automatically disappear from the screen).

Twin Lead Wire * The more commonly used name for the two strand 300 Ohm antenna wire used with many indoor and outdoor antenna systems. In many cases this type of antenna wire requires an additional adapter (or balun) in order to connect to the 75 Ohm Input terminals designed into the more recent Televisions and VCRs



<p>Accessories/Optional6, 7, 31, 34, 37, 56, 59</p> <p>Add/Delete Channels8, 28, 29</p> <p>Advance Buttons.....12</p> <p>Audio Controls20-21, 31</p> <p>Audio/Video Input10, 34, 50, 56</p> <p>Automatic Programming8, 28</p> <p>Auto Volume Control40</p> <p>Battery Installation.....12, 38</p> <p>Cable TV Connections/Settings.....6, 7, 8, 27</p> <p>Censor Channels32</p> <p>Channel Guide41</p> <p>Channel/Time Display25, 26, 41</p> <p>Channel Memory8, 28, 29</p> <p>Channel/Time Reminder.....25</p> <p>Clock Setting22</p> <p>Closed Captioning23</p> <p>Convergence30</p> <p>Controls/TV8, 12</p> <p>Controls/Remote13, 15, 38</p> <p>Exit.....14</p> <p>Factory Reset42</p> <p>Features4</p> <p>First Time Set Up.....8</p> <p>Glossary/TV Terms58</p>	<p>Inputs/Audio and Video10, 34-37, 50, 56</p> <p>Menu14</p> <p>Minus(-)/Plus (+) Buttons.....14</p> <p>Picture-In-Picture (PIP).....10, 50-56</p> <p>Power Light Indicator12</p> <p>Precautions/Safety2, 3, 57</p> <p>Remote Control13, 15, 38-49, 52-53</p> <p>RF Coaxial Cable.....6, 7, 34, 50, 56</p> <p>RF Switcher59</p> <p>Reminder/Time and Channel.....25</p> <p>Second Audio Program (SAP).....21</p> <p>Sensor Remote12</p> <p>Sleep Timer.....24</p> <p>Smart Sound (Auto Volume).....40</p> <p>Status Button.....14, 38</p> <p>Stereo Light Indicator21</p> <p>Surround Sound37</p> <p>Time/Channel Display22, 25, 26, 41</p> <p>VCR Button12, 34</p> <p>VCR/TV Connections.....7, 10, 34, 50, 56</p> <p>Tips for Service.....57</p> <p>TV Speaker Switch.....31</p> <p>Warranty60</p>
--	--

RF SWITCHER INFORMATION

An optional AK9232 RF Switcher is available that will allow an Antenna/Cable TV signal input and another video accessory (VCR, Video Disc Player, etc.) to be connected to the TV at the same time.

The accessory RF switcher can be purchased or ordered from your dealer. If your dealer does not carry the accessory, call the toll free Parts Information Center number.

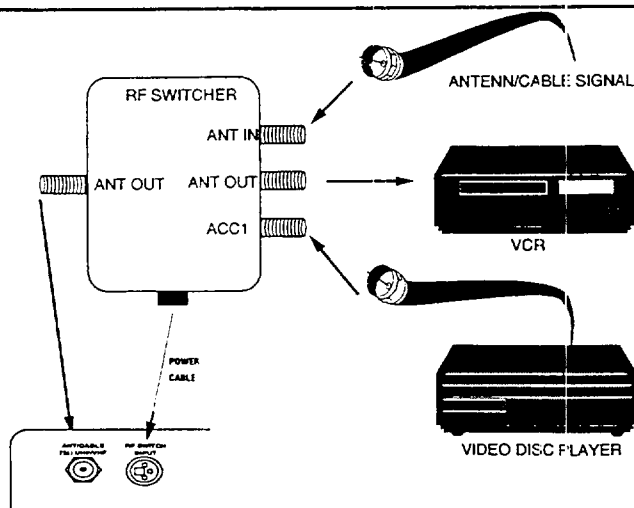

PROJECTION TELEVISION**One (1) Year In Home Service Labor Warranty****Thirty (30) Day Exchange Warranty Projection TV Screen****One (1) Year Exchange Warranty Parts****Two (2) Year Exchange Warranty on Cathode Ray Tube**

For purchases outside the U.S., see applicable warranty from country of purchase.

This warranty gives you specific legal rights and you may also have other rights which vary from state to state.

Parts and Labor

For one year (30 days for the Projection TV screen) after the date of purchase, an Authorized Service Center will repair any product defect and replace any defective part, including the cathode ray tubes and lens without charge to you for parts or labor.

Replacement Cathode Ray Tubes

Except for return shipping cost, an Authorized Service Center will, for two (2) years after installation of the TV, replace a defective cathode ray tube without charge for the replacement tube. If the tube replacement is made after one year, you must pay for all labor and home service charges to replace it. Replacement parts and tubes installed during the warranty period are warranted only for the balance of the original warranty period.

Replacement "Clear-Vu" Lens

The "Clear-Vu" Lens is warranted against manufacturing defects, to the original purchaser, for the lifetime of the product. If the lens replacement is made after one year, you must pay for the labor and home service charges to replace it.

What the Purchaser Must Do

Before you call for service, check your operating instruction booklet. A slight adjustment of the customer controls discussed in your instruction booklet may save you a service call.

If you require service during the warranty period, you must contact an Authorized Service Center to arrange for repair. The Service Center must be allowed to keep defective parts.

Warranty service will be performed by an Authorized Service Center. We suggest that you contact your dealer. If your dealer does not operate an Authorized Service Center, he will direct you to the Authorized Service center engaged by him to service the product he sells.

If you reside in an area where we have a Factory Service Center (see the Factory Service Center address directory supplied with your product literature), you can contact them to schedule a convenient time for an In-Home service call.

YOU MUST PRESENT PROOF OF THE DATE ON WHICH THE PROJECTION TV WAS FIRST PURCHASED (SALES RECEIPT OR OTHER EVIDENCE) WHEN REQUESTING SERVICE OR REPLACEMENT PART WARRANTY PERFORMANCE.

Warranty Exclusions

Your Warranty Does Not Cover:

Labor charges for set installation or set-up, adjustment of customer or preference controls, and installation or repair of antenna systems outside the TV set.

Product repair and/or part replacement because of misuse, accident, unauthorized repair or other cause not within the control of Philips Consumer Electronics Company.

Reception problems caused by signal conditions or cable or antenna systems outside the TV.

A television purchased, used or serviced outside the U.S.A., Puerto Rico and the Virgin Islands, or used for commercial or institutional purposes.

Incidental or consequential damages resulting from the product. Some states do not allow the exclusion of incidental or consequential damages, so the above exclusion may not apply to you.

ALL IMPLIED WARRANTIES INCLUDING IMPLIED WARRANTIES OF MERCHANTABILITY AND FITNESS FOR A PARTICULAR PURPOSE, ARE LIMITED IN DURATION TO THE DURATION OF THIS EXPRESS WARRANTY. Some states do not allow limitations on how long an implied warranty lasts, so the above limitation may not apply to you.

IMPORTANT REMINDER

PLEASE FILL OUT AND MAIL YOUR WARRANTY REGISTRATION CARD PROMPTLY. IT WILL BE EASIER FOR US TO NOTIFY YOU IF IT SHOULD EVER BE REQUIRED. PLEASE ALSO KEEP YOUR SALES RECEIPT AND ANY OTHER PROOF OF PURCHASE INFORMATION.

Please write your Model and Serial numbers below. The numbers are located on the back of your unit. Please remember to have these numbers on hand any time you call.

MODEL NO. _____

SERIAL NO. _____

PHILIPS SERVICE COMPANY • P.O. BOX 555 •
JEFFERSON CITY, TENNESSEE 37760 • (615) 475-8869

**QUESTIONS ABOUT THIS PRODUCT?
CALL OUR INFORMATION CENTER.
800-531-0039**