

Trinitron[®] Color TV

Operating Instructions

KV-27XBR45
KV-27XBR45M
KV-32XBR45
KV-32XBR85

WARNING

To prevent fire or shock hazard, do not expose the television to rain or moisture.

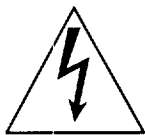
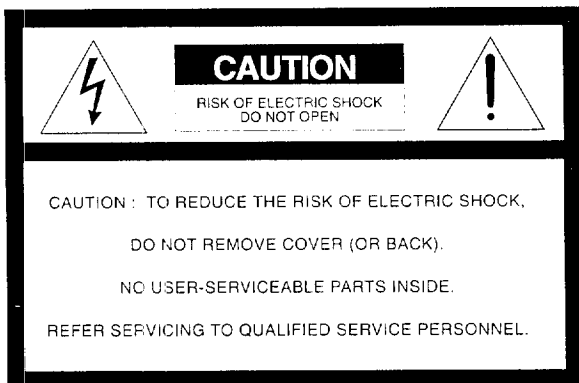

This symbol is intended to alert the user to the presence of uninsulated "dangerous voltage" within the product's enclosure that may be of sufficient magnitude to constitute a risk of electric shock to persons.



This symbol is intended to alert the user to the presence of important operating and maintenance (servicing) instructions in the literature accompanying the appliance.

CAUTION

To prevent electric shock, do not use this polarized AC plug with an extension cord, receptacle or other outlet unless the blades can be fully inserted to prevent blade exposure.

Precautions

Safety

- Operate the TV only on 120 V AC.
- One blade of the plug is wider than the other for safety purposes and will fit into the power outlet only one way. If you are unable to insert the plug fully into the outlet, contact your dealer.
- Should any liquid or solid object fall into the cabinet, unplug the TV and have it checked by qualified personnel before operating it further.

- Unplug the TV from the wall outlet if you are not going to use it for several days or more. To disconnect the cord, pull it out by the plug. Never pull the cord itself.

For details concerning safety precautions, see the supplied leaflet "IMPORTANT SAFEGUARDS."

Installing

- To prevent internal heat build-up, do not block the ventilation openings.
- Do not install the TV in a hot or humid place, or in a place subject to excessive dust or mechanical vibration.

CAUTION

When using TV games, computers, and similar products with your TV, keep the brightness and contrast functions at low settings. If a fixed (non-moving) pattern is left on the screen for long periods of time at a high brightness or contrast setting, the image can be permanently imprinted onto the screen. These types of imprints are not covered by your warranty because they are the result of misuse.

You are cautioned that any changes or modifications not expressly approved in this manual could void your authority to operate this equipment.

Note on Closed Caption (Caption Vision)

This television receiver provides display of television closed captioning in accordance with § 15.119 of the FCC rules.

Note to CATV system installer

This reminder is provided to call the CATV system installer's attention to Article 820-40 of the NEC that provides guidelines for proper grounding and, in particular, specifies that the cable ground shall be connected to the grounding system of the building, as close to the point of cable entry as practical.

Use of this television receiver for other than private viewing of programs broadcast on UHF or VHF or transmitted by cable companies for the use of the general public may require authorization from the broadcaster / cable company and / or program owner.

Owner's Record

The model and serial numbers are located at the rear of the TV. Record these numbers in the spaces provided below. Refer to them whenever you call upon your Sony dealer regarding this product.

Model No. _____

Serial No. _____

Table of contents

- 4 Welcome!
- 4 About this manual

Getting Started

- 5 Step 1: Connections
- 12 Step 2: Setting up the remote control
- 13 Step 3: Installing the glass door and adjusting the shelf
- 14 Step 4: Setting up the TV automatically (AUTOSET UP)
- 16 Step 5: Changing the menu language

Operations

- 17 Watching the TV
- 18 Watching two programs at the same time—PIP and P&P
- 20 Adjusting the picture (VIDEO)
- 22 Adjusting the sound (AUDIO)
- 23 Listening to surround sound (SURROUND)
- 24 Selecting stereo or bilingual programs (MTS)
- 24 Setting the speakers (SPEAKER)
- 25 Selecting audio out (AUDIO OUT)
- 25 Listening to orchestra seat effect sound—OSE
- 26 Listening with the cordless headphones
- 28 Selecting the program palette (PROGRAM PALETTE)
- 28 Setting daylight saving (DAYLIGHT SAVING)
- 29 Setting the clock (CURRENT TIME SET)
- 30 Setting the timer to turn the TV on and off (ON/OFF TIMER)
- 31 Blocking out a channel (CHANNEL BLOCK)
- 32 Setting up favorite channels (CHANNEL GUIDE)
- 33 Setting captions to channels (CHANNEL CAPTION)
- 34 Setting video labels (VIDEO LABEL)
- 35 Selecting Caption Vision (CAPTION VISION)
- 36 Operating video equipment
- 38 Operating a cable box

Additional Information

- 40 Troubleshooting
- 42 Specifications
- 43 **Index**

The captions in parentheses indicate menu names.

Welcome!

Thank you for purchasing the Sony Trinitron® Color TV. Here are some of the features you will enjoy with your TV:

- **On-screen menus** let you adjust the picture quality, sound, and various other settings.
- **Surround system** simulates the sound quality of a concert hall or movie theater.
- **Two-tuner Picture-in-Picture or Picture & Picture** allows you to watch another TV channel, video or cable image as a window or left picture.
- **Orchestra Seat Effect (OSE)** feature restores the harmonic balance of the sound to dramatically improve the overall reproduction of programs. It gives the sound more clarity, depth, and definition, making the sound more dynamic.
- **IR transmitter** allows you to listen to a TV program with the cordless headphones.
- **Remote Control** can operate Sony video and Sony multi-disc players. Other manufacturer's video equipment might also be compatible with this remote control.
- **Center speaker** allows you to enjoy the benefits of Dolby Pro Logic by using the speakers of the TV as the center speaker.

About this manual

The instructions in this manual are for models *KV-27XBR45*, *KV-27XBR45M*, *KV-32XBR45*, and *KV-32XBR85*. Before you start reading this manual please check your model number which is displayed on the rear of the TV. Model *KV-27XBR45* is used for illustration purposes in this manual. Any exceptions in operations between models are clearly indicated in the text. For example, "*KV-32XBR85 only.*"

The following instructions describe operation based on using the remote control buttons. Basic functions can also be performed by using buttons on the TV.

Step 1: Connections

Either an indoor antenna or outdoor antenna should be used with your TV. However, we recommend that you connect an outdoor antenna or a cable TV system to get better picture quality.

To access AUDIO/VIDEO jacks and AC cord on KV-32XBR85, remove the back panel (see page 9).

How to connect different types of cables

The illustrations below show the examples of connecting different types of cables to the TV directly.

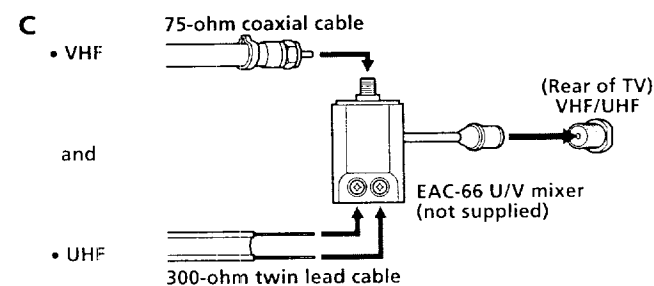
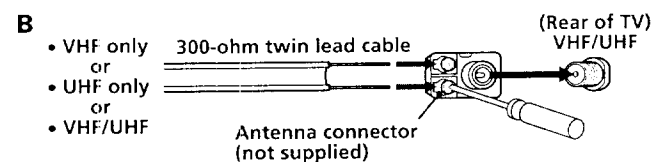
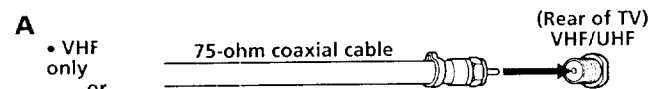

Notes

- Most VHF/UHF combination antennas have a signal splitter. Remove the splitter before attaching the appropriate connector.
- If a U/V mixer is used, snow and noise may appear in the picture when viewing cable TV channels over 37.

Connecting an antenna/cable TV system without a VCR

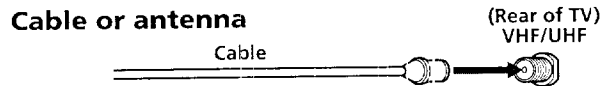

Cable box

If your cable company requires you to connect a cable box, make the connection as follows:

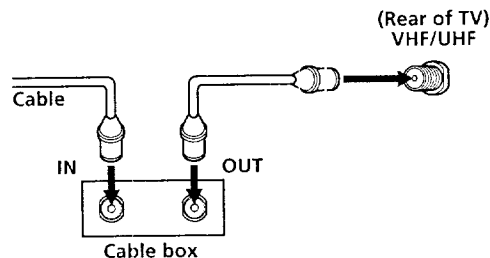

Cable box and cable

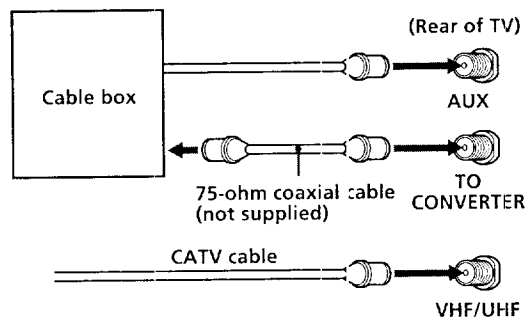

Pay cable TV systems use scrambled or encoded signals requiring a cable box* in addition to the normal cable connection.

* The cable box will be supplied by the cable company.

Note

- You cannot watch the signal through AUX connector as a window picture.

Cable and antenna

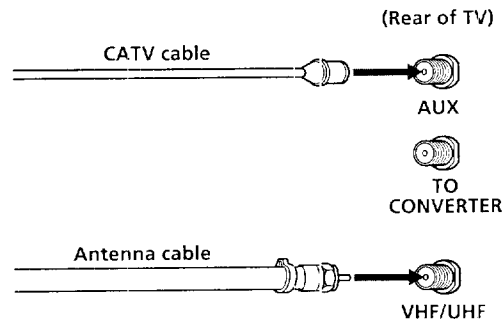

Note

- Do not connect anything to the TO CONVERTER connector in this case.

Connecting an antenna/cable TV system with a VCR

For connection details, see the instruction manual of your VCR. Before making connection, disconnect the AC power cords of the equipment to be connected.

After making these connections, you will be able to do the following:

- View the playback of video tapes
- Record one TV program while viewing another program
- Watch two TV programs simultaneously by using the PIP and P&P features.

Without a cable box

To a VCR

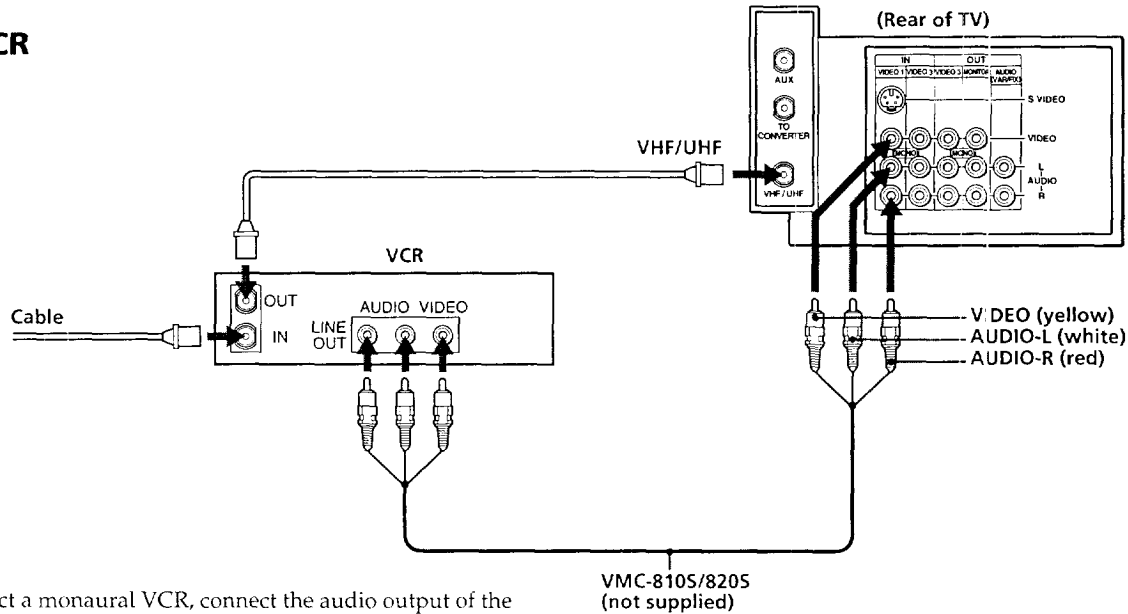

Note

- To connect a monaural VCR, connect the audio output of the VCR to AUDIO-L (mono) of VIDEO 1 IN on the TV.

To an S video equipped VCR

If your VCR has an S video output jack, make the connections as shown below. S Video must be selected as the VIDEO 1 input mode in the VIDEO LABEL menu which is described on page 34.

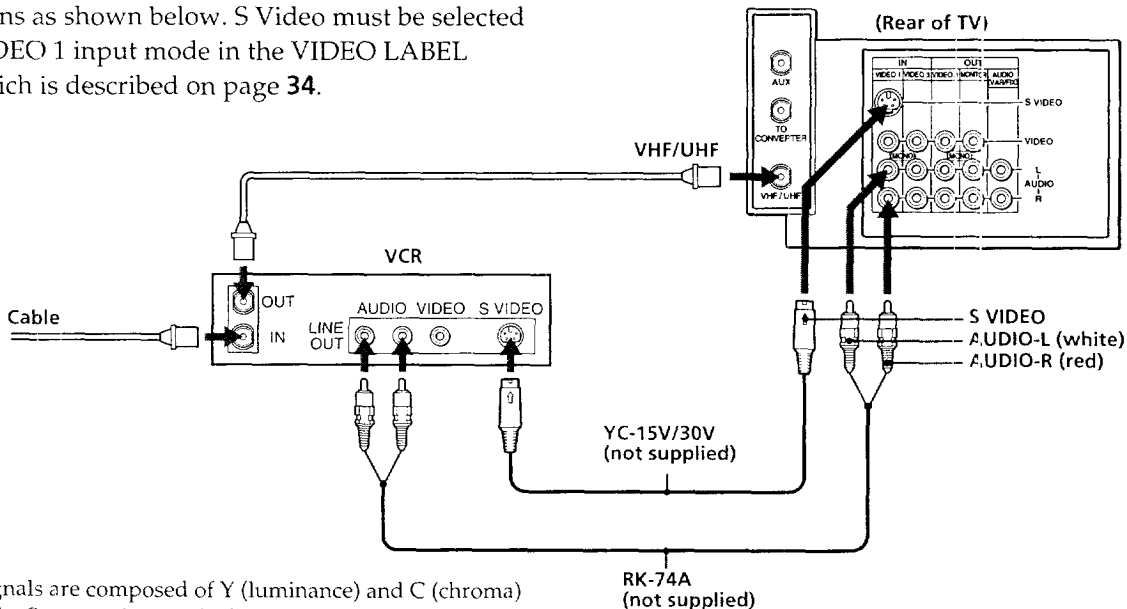

Note

- Video signals are composed of Y (luminance) and C (chroma) signals. The S connection sends the two signals separately preventing degradation, and gives better picture quality compared to conventional connection.

With a cable box

To a VCR

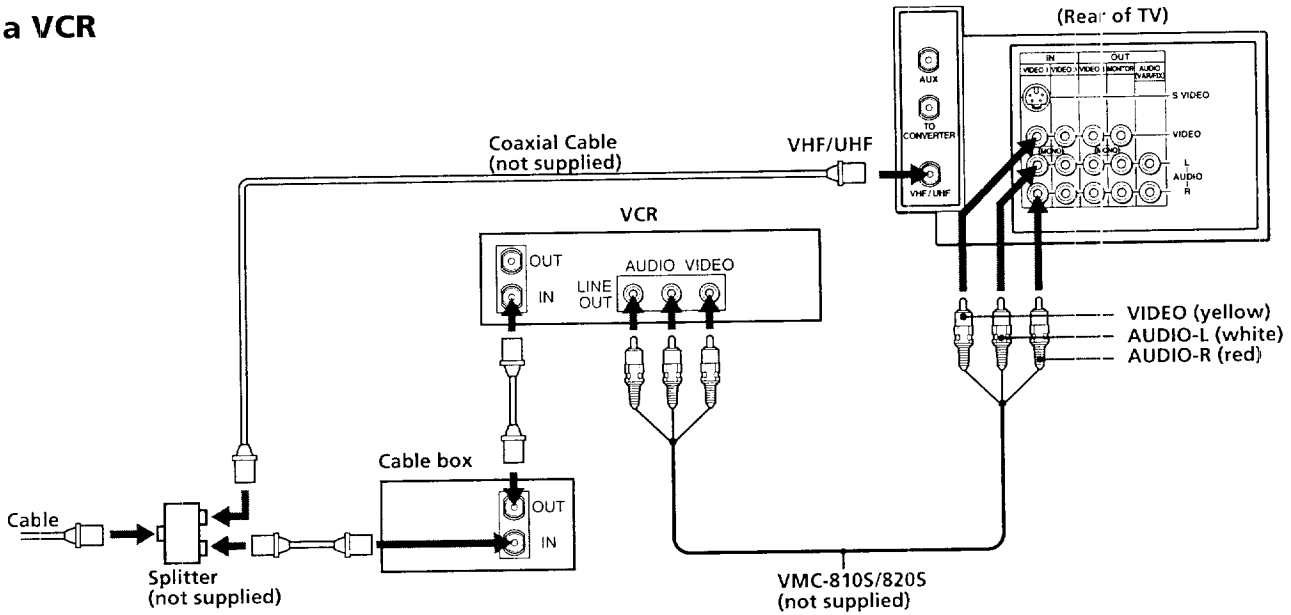

Notes

- To connect a monaural VCR, connect the audio output of the VCR to AUDIO-L (mono) of VIDEO 1 IN on the TV.
- The VHF/UHF connection provides an audio and video signal when the VCR and cable box are turned off.

To an S video equipped VCR with a cable box

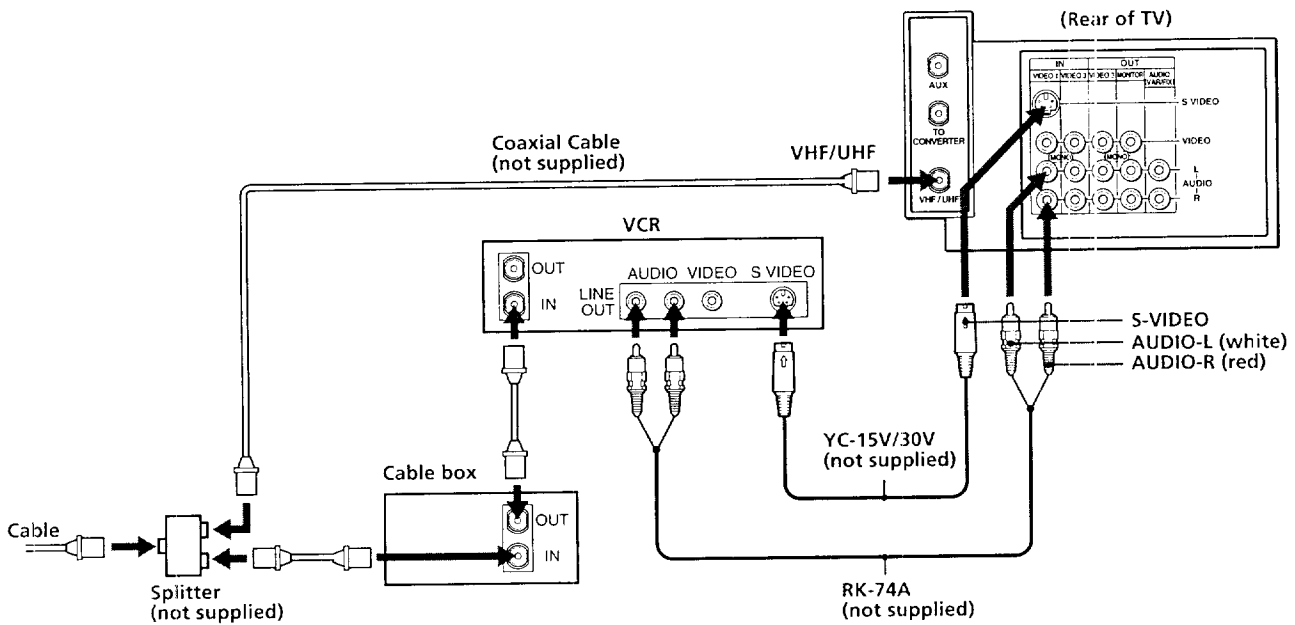

Note

- The VHF/UHF connection provides an audio and video signal when the VCR and cable box are turned off.

Connecting a camcorder

This connection is convenient for viewing a tape played by a camcorder.

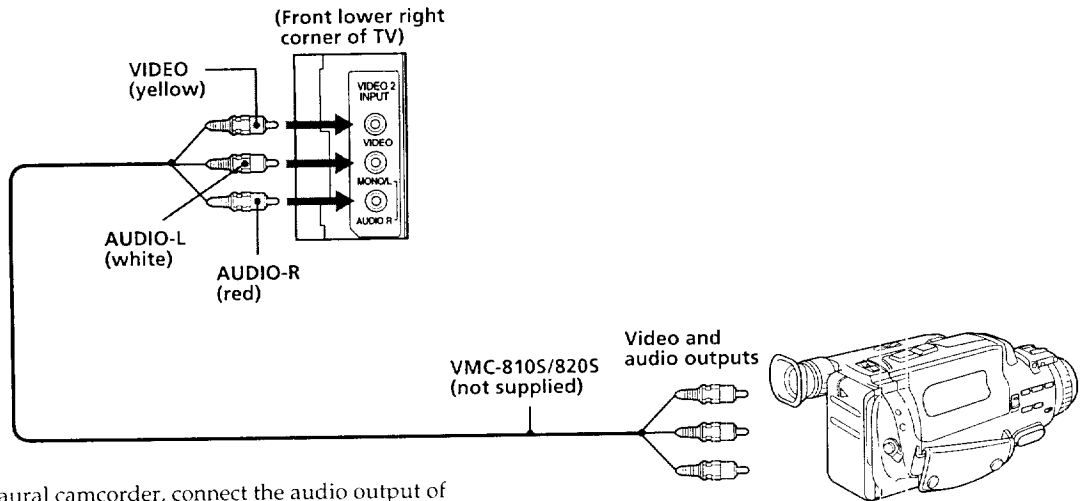

Note

- To connect a monaural camcorder, connect the audio output of the VCR to AUDIO-L (mono) of VIDEO 2 INPUT on the TV.

Connecting two VCRs for tape editing using VIDEO 3 IN and OUT

Watching a different image while recording

If you connect the VCR for playback to the VIDEO 3 IN jacks and the VCR for recording to the VIDEO 3 OUT jacks, a program from the playback VCR will be recorded on the recording VCR.

Please note that VIDEO 3 OUT can only output a program from VIDEO 3 IN. During the above recording process you can view video sources from either antenna, cable, VIDEO 2 IN or VIDEO 1 IN jacks as well.

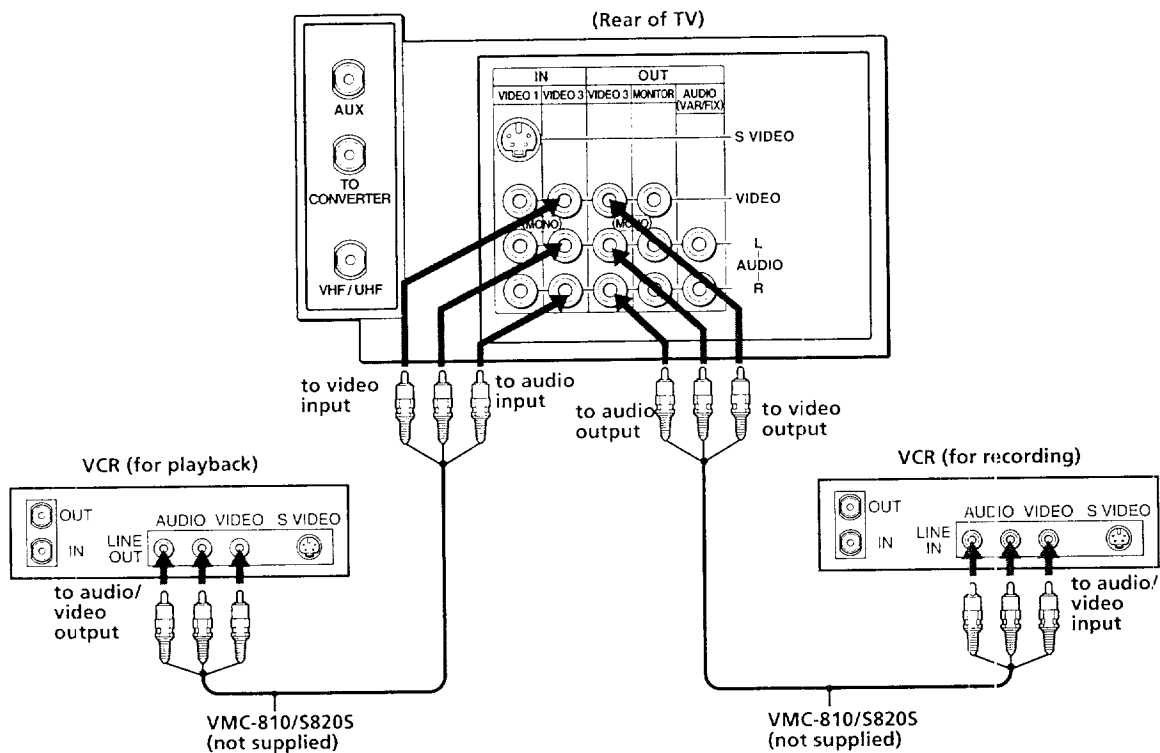

Connecting active super woofer

■ KV-32XBR85 only

This connection allows you to enjoy the sound of the active super woofer. If you connect an audio system to the active super woofer, you can enjoy the sound of the audio system and the active super woofer simultaneously.

The woofer volume varies according to the TV volume. Use the woofer control located in the front of the active super woofer to adjust the intensity of the bass.

Remove the back panel to access AUDIO/VIDEO jacks and AC cord. Replace the back panel when finished.

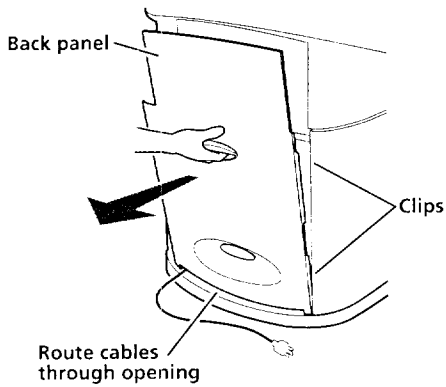

Notes

- If you do not use the TV for more than 20 seconds, the active super woofer is turned off automatically to save on power and consumption.
- When you release MUTING, the sound of the woofer is heard before that of the TV. This is normal.
- If you set SPEAKER to OFF in the AUDIO menu and select FIXED in the AUDIO OUT menu (page 25), the volume of the woofer may be excessive. We recommend that you set SPEAKER to ON when you use the active super woofer.
- You should only connect KV-32XBR85 to the AC outlet on the active super woofer.
- If you connect an audio system to the active super woofer, set the amplifier's function to INPUT.

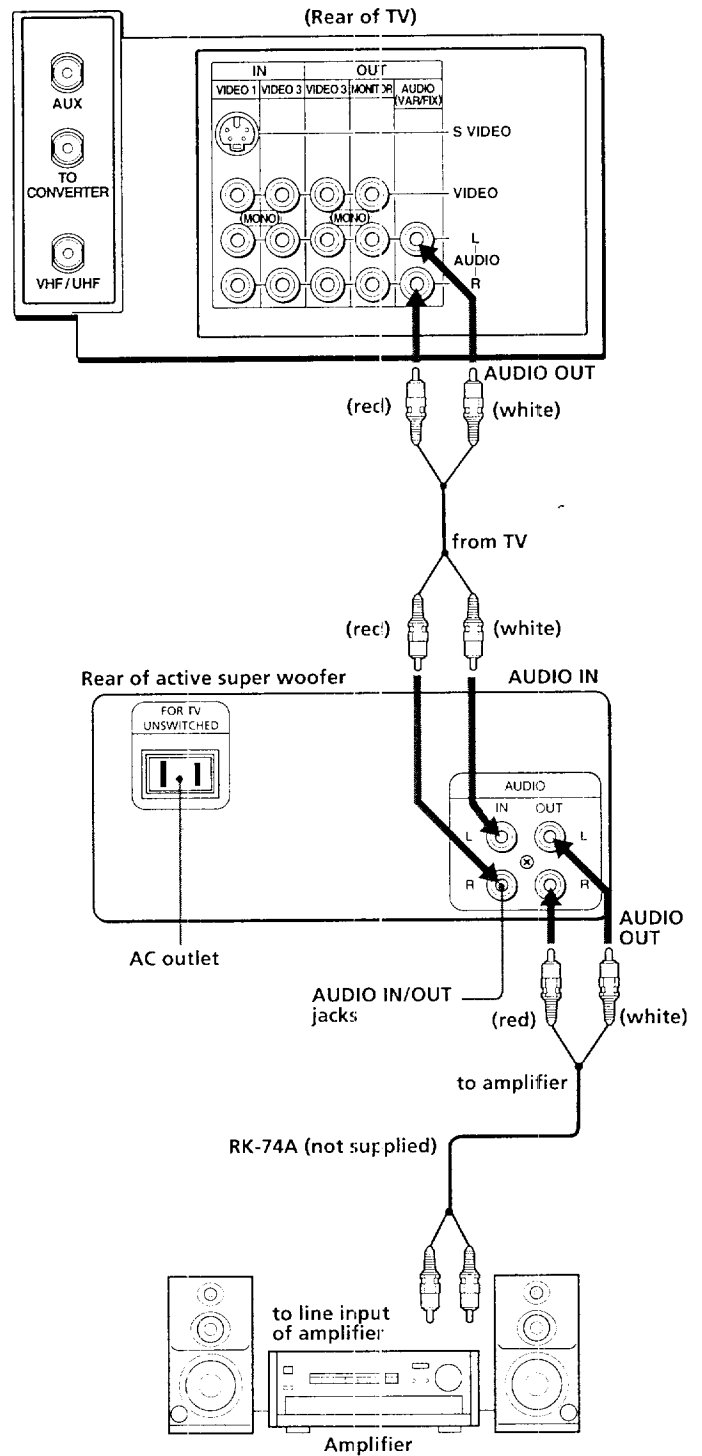



Using the TV speakers as center speakers

This feature allows you to enjoy the benefits of Dolby Pro Logic by using the speakers of the TV as the center speaker. To utilize this system you must have an amplifier that is Dolby Pro Logic compatible. Connect the speaker wires from the amplifier's center channel output terminals to the TV's CENTER SPEAKER IN terminals. Both right and left terminals must be connected to receive an audio signal. After making the above connections select "SPEAKER : CENTER" from the AUDIO menu (page 22). The left and right audio channels can be heard through your audio system speakers. Please note that in this set up the volume can only be adjusted by your amplifier.

Notes

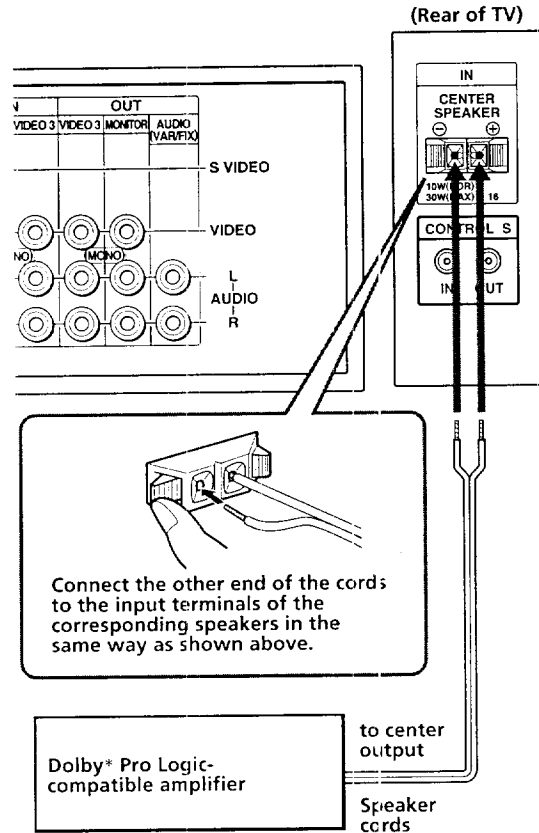
- Always match the speaker cord and terminal colors when making the connections.
- Unplug the TV when making the connections. If the exposed speaker cord wires touch while the TV is plugged in, the TV may short-circuit and be damaged.
- Do not pull on the speaker cords.
- Always turn off the amplifier power before connecting to CENTER SPEAKER IN.
- Always match the speaker cord and terminal colors when making the connection.



* Manufactured under license from Dolby Laboratories Licensing Corporation. Additionally licensed under one or more of the following patents; U.S. numbers 3,632,886, 3,746,792 and 3,959,590. "Dolby" and the double-D symbol  are trademarks of Dolby Laboratories Licensing Corporation.

Connecting other Sony equipment with CONTROL S jack

This feature allows you to control your TV and other Sony components with one remote control. You can either control the TV with a remote control from a Sony component or control the Sony component with the TV's remote control. The connections for the above options are described below.

- To control other Sony equipment with the TV's remote commander, connect the input of the equipment to CONTROL S OUT jack on the TV.
- To control the TV with the remote commander of other Sony equipment, connect the output of the equipment to CONTROL S IN jack on the TV.

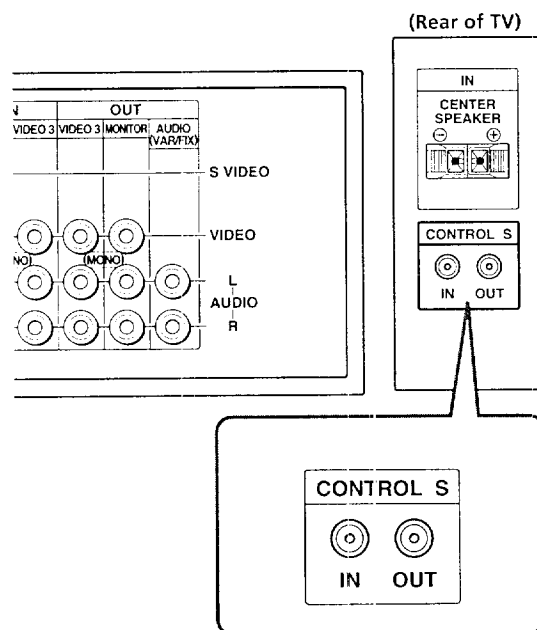

Getting Started

Step 2: Setting up the remote control

Insert one size AA (R6) battery (supplied) by matching the + and - on the battery to the diagram inside the battery compartment.

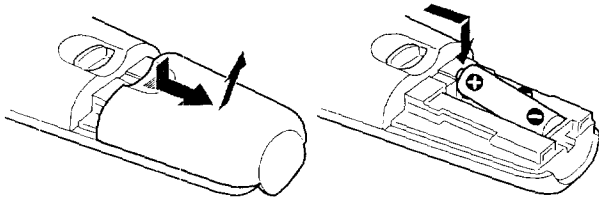

Notes

- With normal use, the battery should last for approximately six months.
- If you do not use the remote control for an extended period of time, remove the battery to avoid possible damage from battery leakage.
- Do not handle the remote control roughly. Do not drop it, step on it or let it get wet.
- Do not place the remote control in direct sunlight, near a heater, or where the humidity is high.

Using the remote control

This remote control has three different operation modes which are selected by sliding a switch on the upper left side of the remote control. The three operation modes are (1) for normal TV viewing, (2) for operating video equipment, and (3) for using the PIP or P&P features. The functions that are necessary for each of the operations appear in the button windows as the switch is moved up or down.

For normal TV viewing

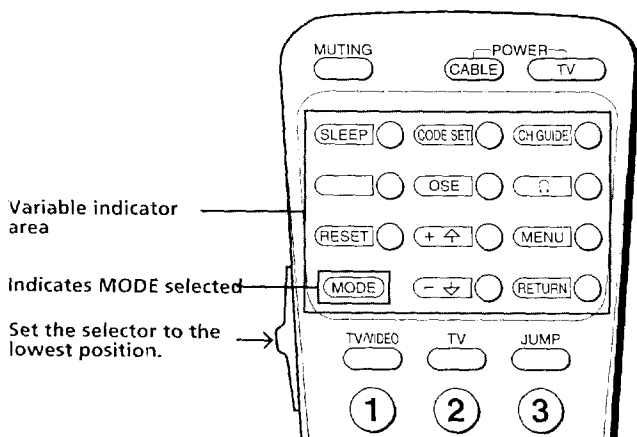

For operating video equipment

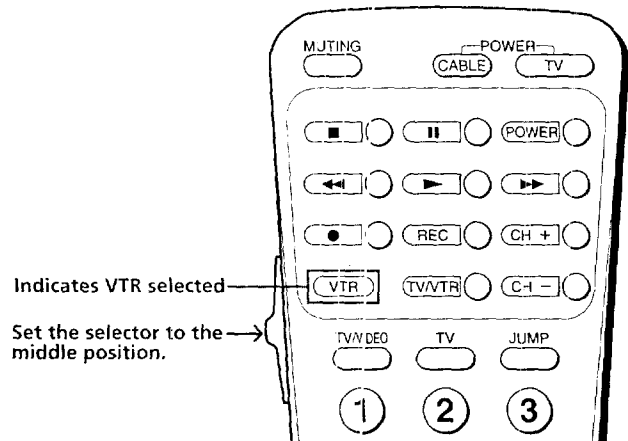

For using the Picture-in-Picture feature

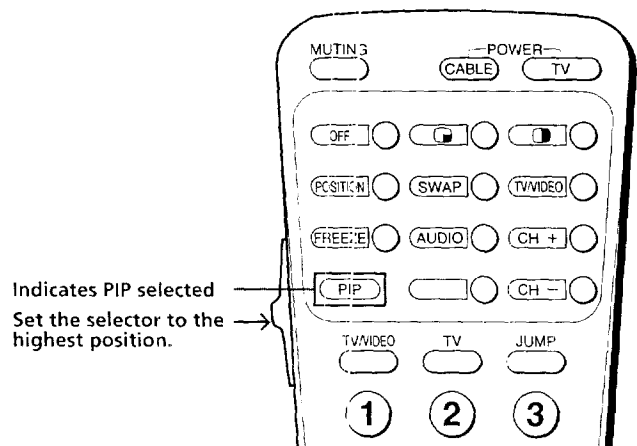

Rear of the remote control

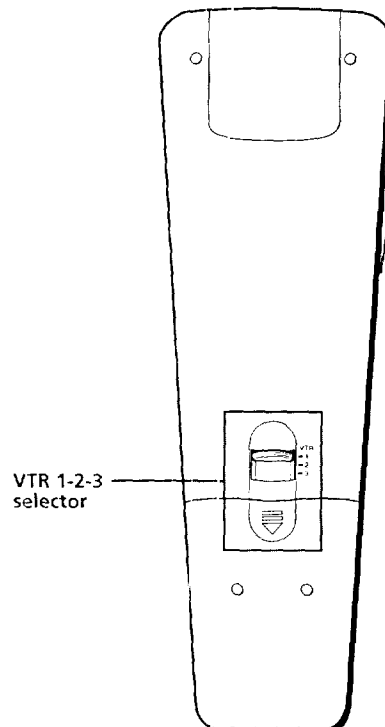

Step 3: Installing the glass door and adjusting the shelf

■ KV-32XBR85 only

Follow these instructions to install the glass door and adjust the shelf.

Installing the glass

- 1 Attach the top hinge, with the screws facing the front of the TV, to the right side of the glass door, tighten the screws snugly, but do not over-tighten. Attach the plate pad to the left side and push the plate over the plate pad.

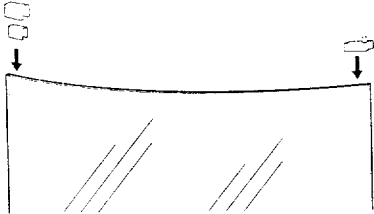

- 2 Insert the bottom hinge into the bushing located at the bottom, right side of the cabinet.

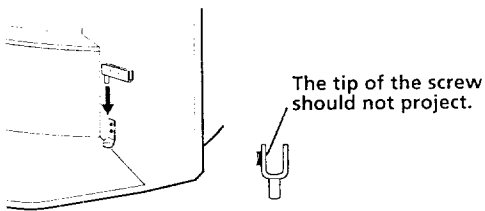

- 3 Push the top, glass door hinge into the top, right bushing and gently slide the glass door into the bottom hinge. Adjust the glass door until level, and tighten the hinge screws.

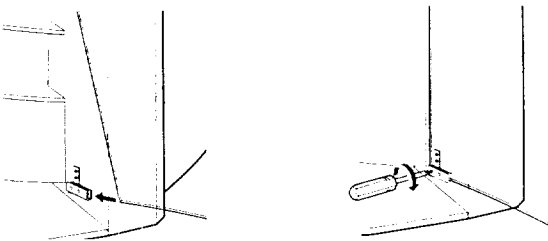

Note

- The glass door in this stand is made of tempered glass. Although it is more shock-resistant than ordinary glass, tempered glass may shatter if it is dropped or receives a sudden shock.

Adjusting the shelf

- 1 Unlock the four shelf supports with a medium Phillips head screwdriver. Turn the screwdriver 90° to unlock the shelf supports.

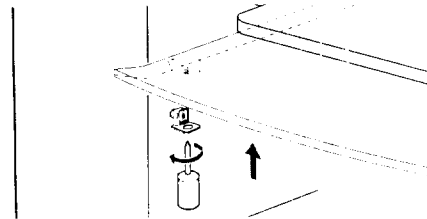

- 2 Gently slide the shelf up and out.

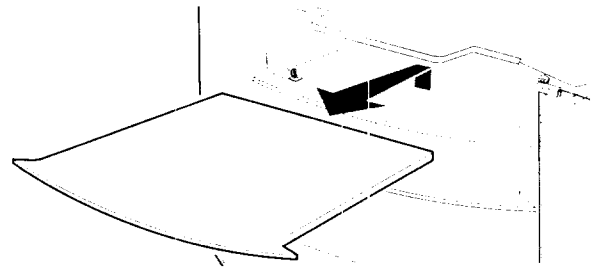

- 3 Insert shelf supports in the appropriate holes. Slide shelf in, align the shelf grooves with the shelf supports, and slide the shelf down.

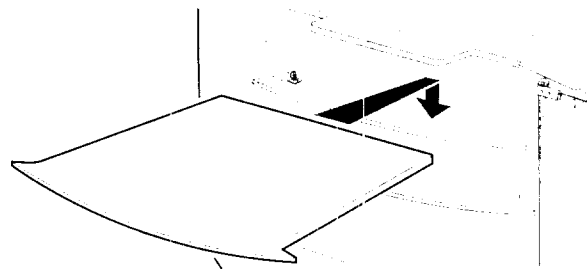

Step 4: Setting up the TV automatically

(AUTO SET UP)

You can set up your TV easily by using AUTO SET UP feature. It presets all the receivable channels. To set up the TV manually, see "Setting cable TV on or off" and "Presetting channels" (page 15, 16).

If the TV is set to a video input, you cannot execute AUTO SET UP. Press TV/VIDEO so that a channel number appears.

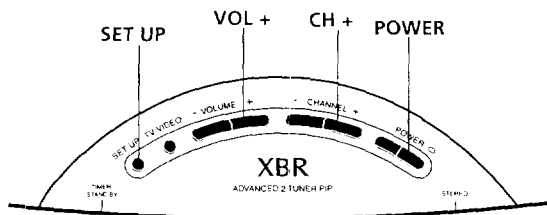

1 Press POWER (TV) to turn the TV on.



2 Press SET UP on the top of the TV.

The menu appears.

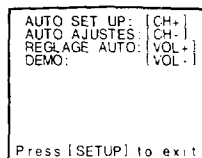

3 Press CHANNEL + to select AUTO SET UP.

If you prefer Spanish or French to English, you can change the on-screen menu language. Press CHANNEL - for Spanish or VOLUME + for French.

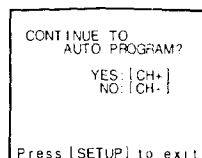
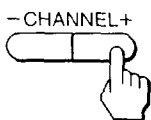

4 Press CHANNEL +.

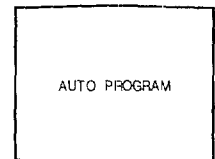
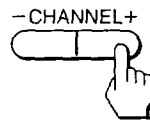

"AUTO PROGRAM" appears on the screen and the TV starts scanning and presetting channels automatically. When all the receivable channels are stored, "AUTO PROGRAM" disappears and the lowest numbered channel is displayed. If the TV receives cable TV channels, CATV is set to ON automatically.

Notes

- If more than 90 seconds elapse after you press a button, the menu disappears automatically.
- In case of using the AUX connector, press the TV button on the remote control first and make sure that "AUX" is displayed beside the channel number on the screen. Then follow steps 2 and 3 above to perform AUTO SET UP.

DEMO: To browse the main functions, press VOL - in step 2. The functions and menus are displayed one by one.

Erasing or adding channels

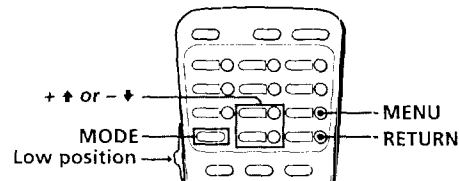

1 Press MENU.

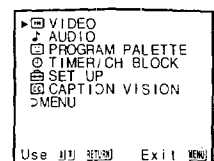
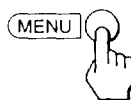

2 Press + ↑ or - ↓ to move the cursor (▶) to SET UP and press RETURN.

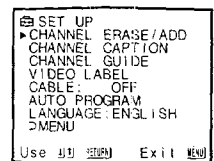

The picture and sound settings will be set to the factory preset condition in the selected language.

3 Press + ↑ or - ↓ to move the cursor (▶) to CHANNEL ERASE/ADD and press RETURN.



4 Erase and/or add the channel you want:

(1) Press + ↑ or - ↓ and press RETURN to select ERASE or ADD.

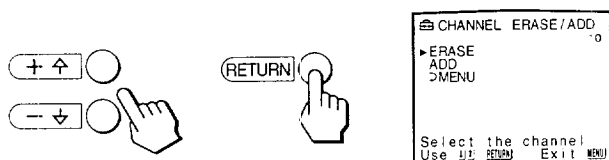

(2) Press CH +/- or 0-9 buttons to select the channel you want to erase or add.

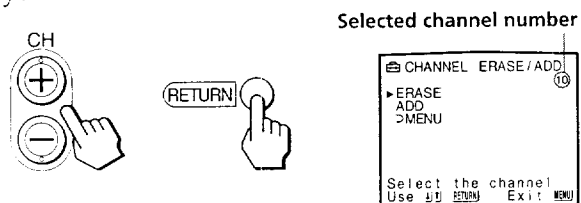

(3) Press RETURN.

- If you selected ERASE in step (1), "-" appears beside the channel number, showing that channel is erased from the preset memory.
- If you selected ADD in step (1), "+" appears beside the channel number, showing that channel is added to the preset memory.

5 To erase and/or add other channels, repeat step 4.

6 When you finish, press MENU.

Notes

- If you erase or add a VHF or UHF channel, the cable TV channel with the same number is also erased or added.
- Erasing and adding channels is also available for the AUX input.

Setting cable TV on or off

This setting allows you to view either broadcast or cable signals. The factory setting for cable TV is ON. If you do not desire to view cable TV, you must turn it off as shown below.

You do not have to do this procedure if you execute AUTO SET UP (page 14). Do this procedure only when you want to set it manually.

1 Press MENU.

2 Press + ↑ or - ↓ to move the cursor (▶) to SET UP and press RETURN.

The SET UP menu appears.

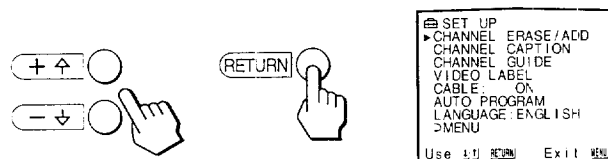

If you are in one of the video modes, the CABLE lettering will be black on the menu. To display the CABLE lettering you must press TV on the remote control until a channel number appears on the screen.

3 Set CABLE to ON or OFF:

(1) Make sure the cursor (▶) is beside CABLE and press RETURN.

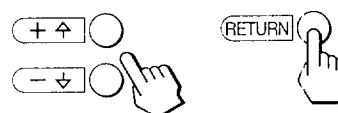

(2) Press + ↑ or - ↓ to select ON or OFF and,

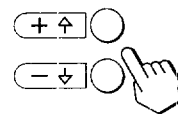

(3) press RETURN.

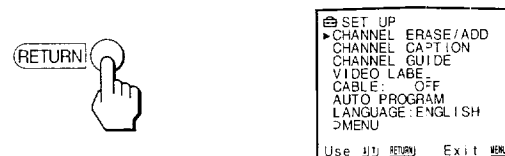

4 Press MENU to return to the normal screen.



Presetting channels

You can preset TV channels easily by using the AUTO PROGRAM feature. Preset channels during the day rather than late at night, since some channels go off the air and will not be preset.

You do not have to do this procedure if you execute AUTO SET UP (page 14). Do this procedure only when you want to set channels manually.

- 1 Press **MENU**.
- 2 Press **+ ↑** or **- ↓** to move the cursor (▶) to **SET UP** and press **RETURN**.

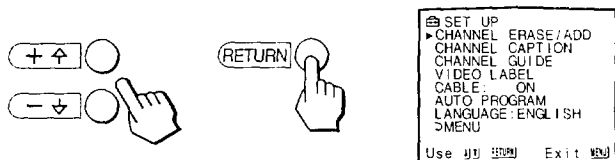

- 3 Press **+ ↑** or **- ↓** to move the cursor (▶) to **AUTO PROGRAM** and press **RETURN**.

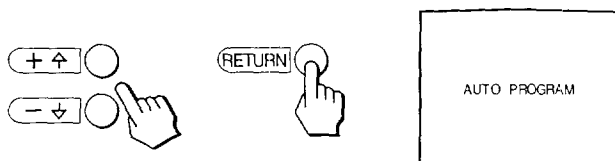

"AUTO PROGRAM" appears on the screen and the TV starts scanning and presetting channels automatically. When all the receivable channels are stored, "AUTO PROGRAM" disappears and the lowest numbered channel is displayed.

- 4 Press **MENU** to return to the original screen.

Notes

- If you are in one of the video modes, the AUTO PROGRAM lettering will be black on the menu. To display the AUTO PROGRAM lettering you must press the TV/VIDEO or TV button until a channel number appears.
- In case of using the AUX connector, AUTO PROGRAM is also available for the AUX input. Press the TV button on the remote commander first and make sure that "AUX" is displayed beside the channel number on the screen. Then follow steps 1 to 3 above.

Step 5: Changing the menu language

If you prefer Spanish or French to English, you can change the menu language. You do not have to do this procedure if you execute AUTO SET UP (page 14). Do this procedure only when you want to set it manually.

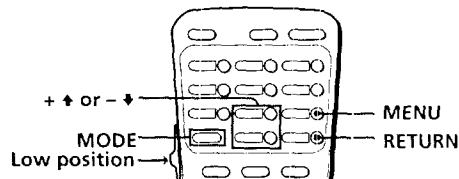

- 1 Press **MENU**.
- 2 Press **+ ↑** or **- ↓** to move the cursor (▶) to **SET UP** and press **RETURN**.
- 3 Press **+ ↑** or **- ↓** to move the cursor (▶) to **LANGUAGE** and press **RETURN**.

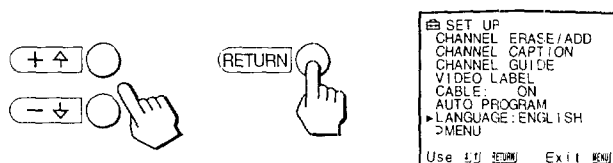

- 4 Press **+ ↑** or **- ↓** to select **ESPAÑOL** or **FRANCAIS** and press **RETURN**.

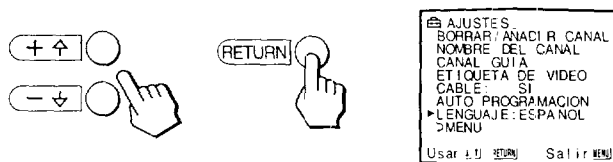

- 5 Press **MENU** to return to the original screen.

Note

- Certain parts of the ESPAÑOL and FRANCAIS menus remain in English.

Watching the TV

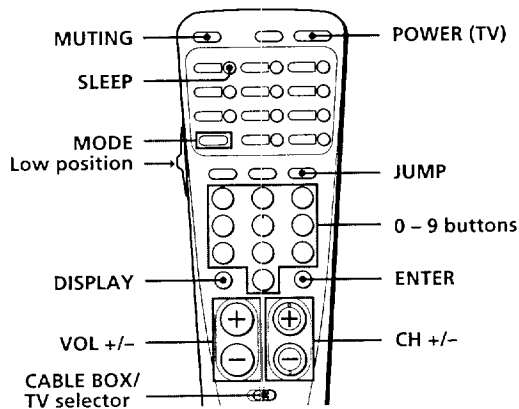

1 Press POWER (TV) to turn the TV on.

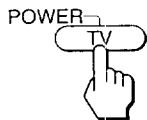

If "VIDEO" appears on the screen, press the TV/VIDEO, TV or CH +/- button until a channel number appears on the screen.

2 Select the desired channel:

To select a channel directly

Press the 0-9 buttons. Press ENTER to select a channel more quickly.

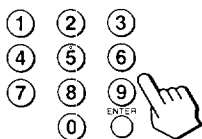

To scan through channels

Press CH +/- until the channel you want to watch appears.

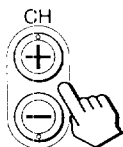

3 Press VOL +/- to adjust the volume.

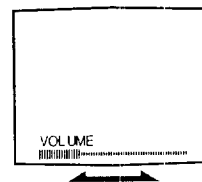
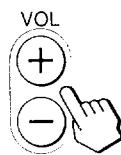

Note

- Set the CABLE BOX/TV selector to TV.

Switching quickly between two channels

You can use the JUMP button to switch or "jump" back and forth between two channels.

Press JUMP.

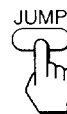

Pressing JUMP again switches back to the last channel selected.

Note

- You cannot jump to channels you scanned through using the CH +/- buttons.

Muting the sound

Press MUTING.

There is no audio and "MUTING" appears on the screen.



To restore the sound, press MUTING again, or press VOL +.

Displaying on-screen information

1 Press DISPLAY.

Channel number, the current time (if set), headphones (if set), and MTS mode (if SAP is selected) are displayed. Headphones and SAP indications disappear after 4 seconds.



(continued)

2 Press DISPLAY again.

Extended Data Service is turned on. If the station provides this service, program information, program type, program length, and a brief description of the program are displayed.



3 Press DISPLAY again.

Caption Vision (if set, and is provided by broadcast) is displayed.



To cancel the display, press DISPLAY again.

Setting the Sleep Timer

The TV stays on for the length of time you specify and then shuts off automatically.

Press SLEEP repeatedly until the time (in minutes) you want appears.

Each time you press SLEEP, the time changes as follows: 30 → 60 → 90 → OFF.



To cancel the Sleep Timer, press SLEEP repeatedly until "SLEEP OFF" appears, or turn the TV off.

Changing the VHF/UHF input to the AUX input

Press TV.

"AUX" appears beside the channel number.

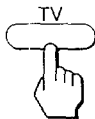

Pressing TV again switches back to the previous input.

Watching two programs at the same time - PIP and P&P

You can watch the main/right picture and a window/left picture simultaneously using the Picture-in-Picture or the Picture-and-Picture (Twin View™) feature

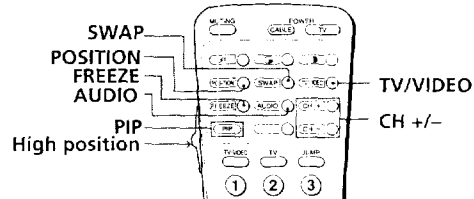

Displaying a window picture - PIP

Press (PIP)

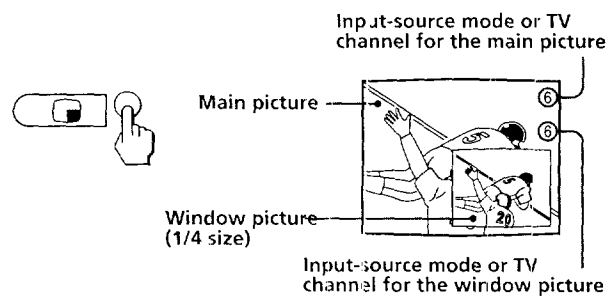

Each time you press (PIP), the size of the window picture changes as follows:

→ 1/4 size → 1/9 size → 1/16 size

To remove the window picture, press OFF.

Notes

- If the main picture is not receiving an image, the right picture may be in black and white.
- The window picture may be affected by the condition of the left picture.

Displaying a left picture - P&P

Press (P&P)

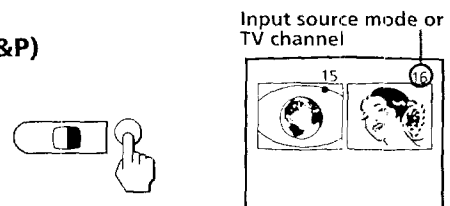

To restore the normal picture, press OFF.

Notes

- If one of the pictures is not receiving an image, the other picture may appear in black and white.
- One picture may be affected by the condition of the other picture.

Changing the input mode

Press TV/VIDEO in the PIP control area to select the input mode.

Each time you press TV/VIDEO, "TV," "VIDEO 1," "VIDEO 2" and "VIDEO 3" appear in sequence.

PIP function

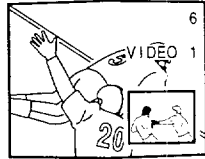

P&P function



The PIP or P&P picture will appear in the same input mode as the last time you used PIP or P&P.

Listening to the sound of the main/right or window/left picture.

Press AUDIO.

The  display appears for a few seconds, indicating that the main/right or window/left picture sound is being received.

PIP function

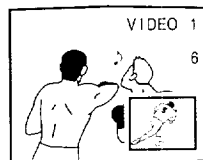

To restore the main picture sound, press AUDIO again.

P&P function

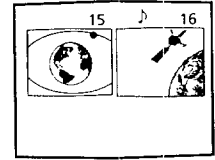

To restore the other screen picture sound, press AUDIO again.

Changing TV channels in the main/right or window/left picture.

Press CH +/- in the PIP remote control area.

PIP feature

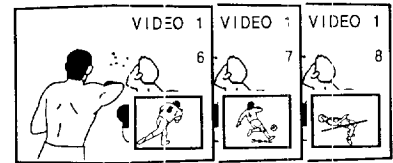
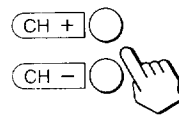

P&P feature

CH +/- in the PIP remote control area only controls the left screen picture.

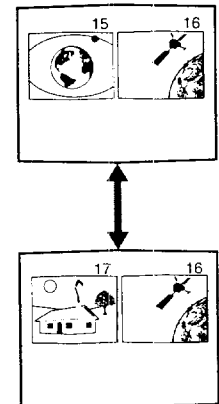
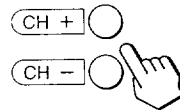

Changing the position of the PIP window picture.

Press POSITION.

Each time you press POSITION, the window picture will move counterclockwise on the screen.

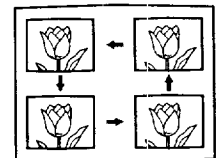

Note

- POSITION is not a P&P feature.

Freezing the TV screen

This feature is useful when you want to write down a recipe from a cooking program, a displayed address or a phone number and so on.

Press **FREEZE**.

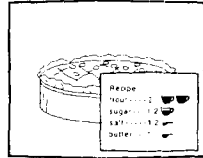

To restore the normal screen, press **FREEZE** again.

Notes

- The frozen TV screen window will appear diagonally across the PIP window picture.
- If using P&P, both screens will freeze when you press **FREEZE**.

Swapping the window/left pictures (PIP) or the main/right pictures (P&P)

Press **SWAP**.

Each time you press **SWAP**, the picture screens and sound will switch places.

PIP feature

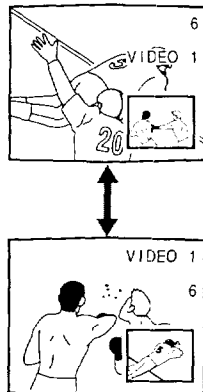
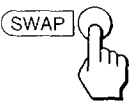

P&P feature

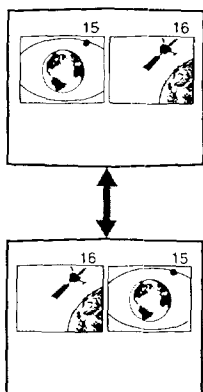
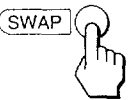

Note

- The channels being received through the AUX jack cannot be displayed as a window picture.

Adjusting the picture (VIDEO)

You can adjust the picture setting of TV programs to your preferences by following the instructions below. These adjustments can also be made for your video input programs.

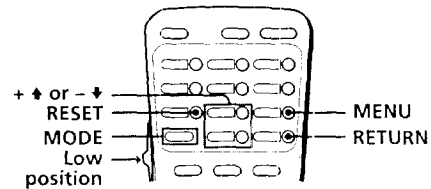

1 Press **MENU**.

2 Make sure the cursor (▶) is beside **VIDEO** and press **RETURN**.

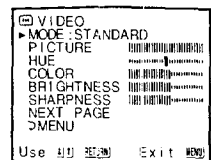
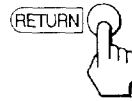

3 Select the item you want to adjust.

For example:

(1) To adjust brightness, press +▲ or -▼ to select **BRIGHTNESS** and,

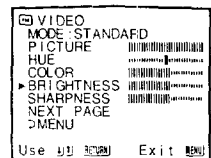
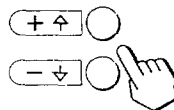

(2) press **RETURN**.



4 Adjust the selected item:

(1) Press + ↑ or - ↓ to adjust the item and,

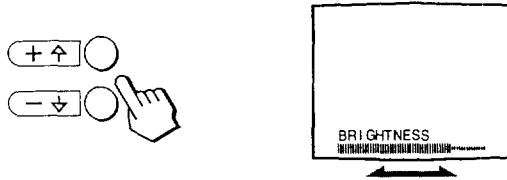

(2) press RETURN.

The new setting appears in the VIDEO menu.



5 To adjust other items, repeat steps 3 and 4.

Description of adjustable items

Item	Press + ↑ to	Press - ↓ to
PICTURE	Increase picture contrast for vivid color	Decrease picture contrast for soft color
HUE	Make overall picture become greenish	Make overall picture become purplish
COLOR	Increase color intensity	Decrease color intensity
BRIGHTNESS	Brighten the picture	Darken the picture
SHARPNESS	Sharpen the picture	Soften the picture

To restore this menu's factory settings

Press RESET while the VIDEO menu is displayed. All the settings of the video mode you are currently in (STANDARD, MOVIE, or SPORTS) are restored to the factory settings.

Selecting the TRINITONE mode

This feature allows you to adjust the color temperature setting (tint) that determines the red and blue tint of a picture. Select the setting that suits your taste.

1 Press MENU.

2 Press + ↑ or - ↓ to select VIDEO and press RETURN.

3 Press + ↑ or - ↓ to select NEXT PAGE and press RETURN.

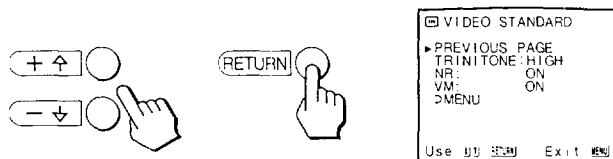

4 Press + ↑ or - ↓ to select TRINITONE and press RETURN.

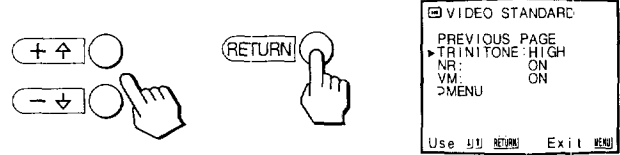

5 Press + ↑ or - ↓ to select HIGH, MEDIUM, or NTSC STD and press RETURN.

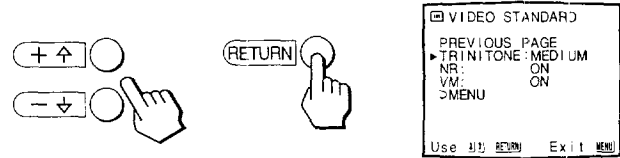

Choose	To
HIGH	Make the picture "cool" or increase bluish tint.
MEDIUM	Make the picture "warm" or increase reddish tint.
NTSC STD	Match the broadcast standard for NTSC color temperature.

Setting NR (picture noise reduction) ON or OFF

This setting allows you to filter out screen picture noise. ON reduces the picture noise and OFF restores the normal picture.

1 Press MENU.

2 Press + ↑ or - ↓ to select VIDEO and press RETURN.

3 Press + ↑ or - ↓ to select NEXT PAGE and press RETURN.

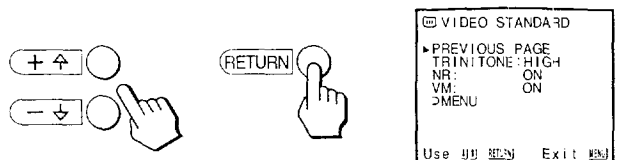

4 Press + ↑ or - ↓ to select NR and press RETURN.

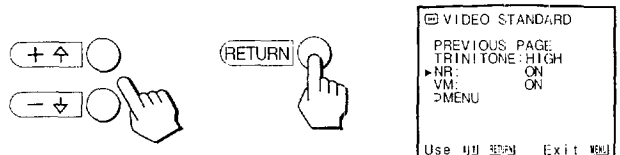

(continued)

- 5** Press + ↑ or - ↓ to select ON, or OFF and press RETURN.

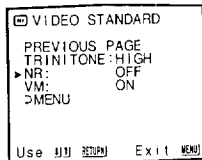
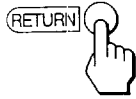
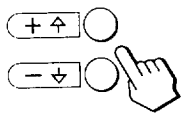

Setting VM (velocity modulation) ON or OFF

Velocity modulation improves picture definition and contrast ratio for an overall sharper picture. The factory setting for VM is ON. Select OFF for a softer picture.

- 1** Press MENU.
- 2** Press + ↑ or - ↓ to select VIDEO and press RETURN.
- 3** Press + ↑ or - ↓ to select NEXT PAGE and press RETURN.

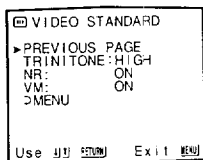
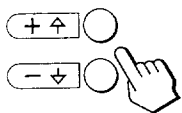

- 4** Press + ↑ or - ↓ to select VM and press RETURN.

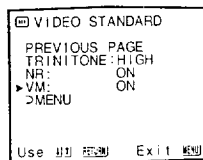
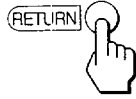
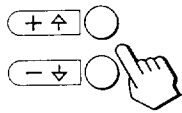

- 5** Press + ↑ or - ↓ to select ON, or OFF and press RETURN.

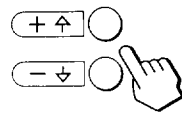

Adjusting the sound (AUDIO)

You can adjust the audio setting of the TV programs to your preferences by following the instructions below. These adjustments can also be made for your video input programs. The TV program settings and video program setting are stored separately.

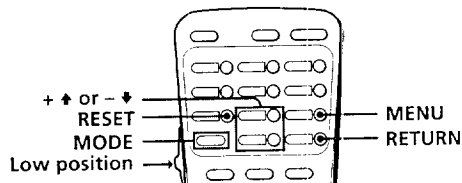

- 1** Press MENU.
- 2** Press + ↑ or - ↓ to select AUDIO and press RETURN.

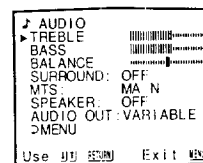
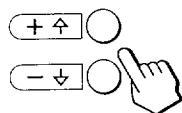

- 3** Select the item you want to adjust.
For example:

(1) To adjust bass, press + ↑ or - ↓ to select BASS and,

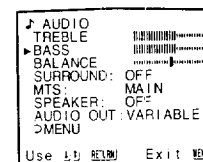
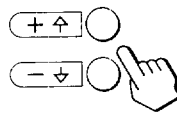

(2) press RETURN.



4 Adjust the selected item:

(1) Press + ↑ or - ↓ to adjust the item and,

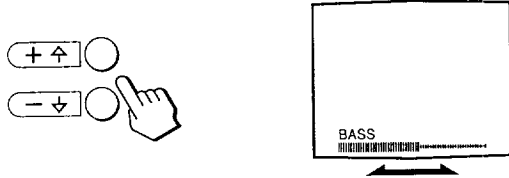

(2) press RETURN.

The new setting appears in the AUDIO menu.



5 To adjust other items, repeat steps 3 and 4 above.

Description of adjustable items

Item	Press + ↑ to	Press - ↓ to
TREBLE	Increase the treble response	Decrease the treble response
BASS	Increase the bass response	Decrease the bass response
BALANCE	Emphasize the right speaker's volume	Emphasize the left speaker's volume

To restore the factory settings

Press RESET while the AUDIO menu is displayed.

Note

- When SPEAKER (page 24) is CENTER and AUDIO OUT (page 25) is in FIXED condition, the sound is set to mid-level and it cannot be adjusted through your TV set.

Listening to surround sound (SURROUND)

SURROUND feature simulates sound reproduction with the atmosphere of a movie theater or a concert hall. Surround sound only works with stereo programs.

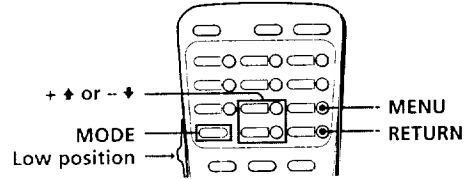

1 Press MENU.

2 Press + ↑ or - ↓ to select AUDIO and press RETURN.

3 Press + ↑ or - ↓ to select SURROUND and press RETURN.

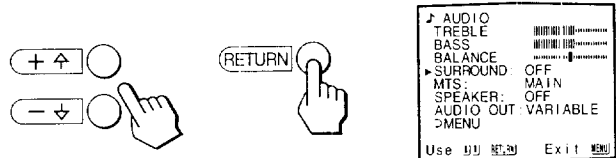

4 Press + ↑ or - ↓ to select ON and press RETURN.

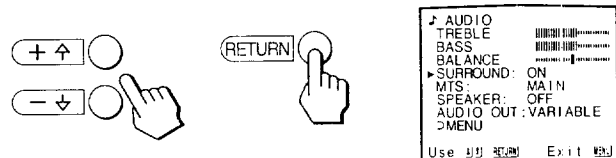

Selecting stereo or bilingual programs

(MTS)

The Multichannel TV Sound (MTS) feature gives you the choice to enjoy stereo sound or Second Audio Programs (SAP) when available. The factory setting is stereo sound (MAIN).

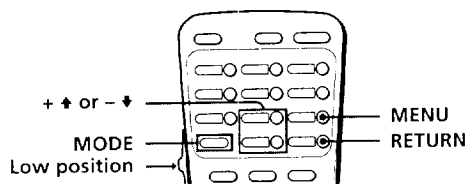

- 1 Press **MENU**.
- 2 Press **+ ↑** or **- ↓** to select **AUDIO** and press **RETURN**.
- 3 Press **+ ↑** or **- ↓** to select **MTS** and press **RETURN**.

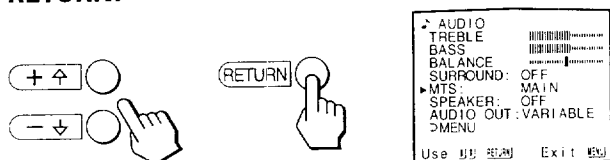

- 4 Press **+ ↑** or **- ↓** to select **MAIN**, **SAP**, or **MONO** and press **RETURN**.



Choose	To
MAIN	Listen to stereo sound. The STEREO indicator on the TV lights up while a stereo broadcast is received.
SAP	Listen to bilingual programs. The sound of non-SAP programs will be muted when SAP is selected.
MONO	Reduce noise during stereo broadcasts.

Note

- Stereo and SAP sounds are subject to program sources. Refer to your local TV program listings.

Setting the speakers

(SPEAKER)

You may switch off the TV speakers when, for example, you want to listen to the sound through a stereo system.

If you use the TV speakers as center speakers and connect a Dolby Pro Logic-compatible amplifier to CENTER SPEAKER IN, after making the connections display the mode set menu and set SPEAKER to "CENTER."

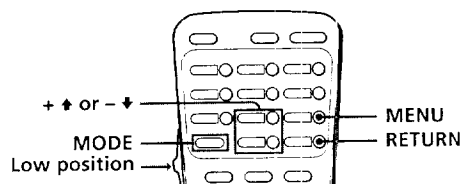

- 1 Press **MENU**.
- 2 Press **+ ↑** or **- ↓** to select **AUDIO** and press **RETURN**.
- 3 Press **+ ↑** or **- ↓** to select **SPEAKER** and press **RETURN**.

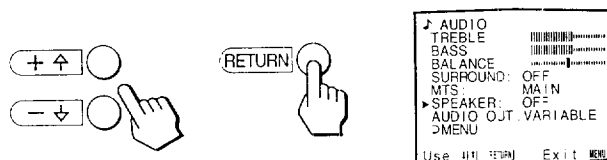

- 4 Press **+ ↑** or **- ↓** to select **CENTER**, **OFF** or **ON**.

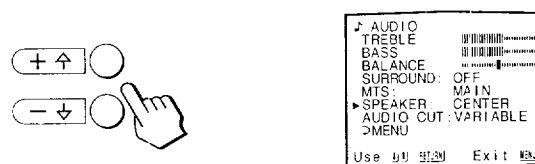

If you select **CENTER** or **OFF** and press **RETURN**, **AUDIO OUT** appears at the bottom of the menu. To adjust **AUDIO OUT**, press **RETURN** and see **AUDIO OUT** (page 25).

To turn the speakers off, change **SPEAKER** from **ON** to **OFF** in the **AUDIO** menu.

Setting audio out (AUDIO OUT)

This setting allows you to select either a fixed or variable audio output. Fixed audio output means that you cannot adjust the volume and sound characteristics through your TV set. Variable output means that you can adjust the volume, bass, treble and balance through your TV set.

If SPEAKER is CENTER or OFF, AUDIO OUT can either be fixed or variable; however, if the SPEAKER is ON, AUDIO OUT is variable.

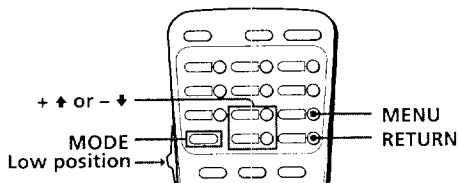

- 1 Follow steps 1-4 in "Setting the speakers" on page 24 to set the speakers to CENTER and press RETURN.

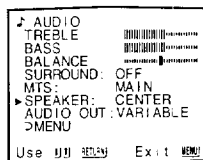

- 2 Press + ↑ or - ↓ to select AUDIO OUT and press RETURN.

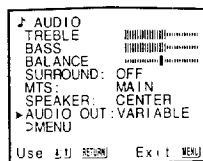
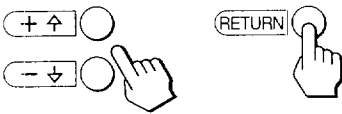

- 3 Press + ↑ or - ↓ to select VARIABLE or FIXED and press RETURN.

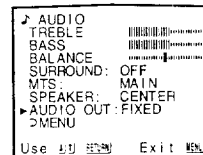

Note

- If SPEAKER is ON, AUDIO OUT will appear in black and you will be unable to adjust AUDIO OUT.

Listening to orchestra seat effect sound—OSE

Orchestra Seat Effect* (OSE) feature restores the harmonic balance of the sound to dramatically improve the overall reproduction of programs. It gives the sound more clarity, depth, and definition, making the sound more dynamic.

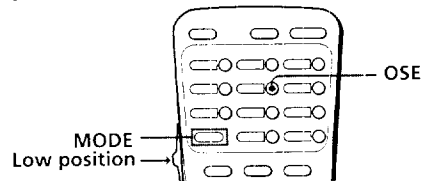

Press OSE.

"ORCHESTRA SEAT BBE: LOW" appears on the screen.

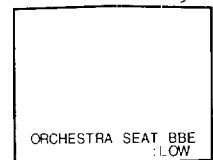

Press OSE again.

"ORCHESTRA SEAT BBE: HIGH" appears.

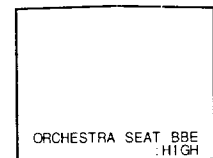

Press OSE again.

To turn off the OSE.

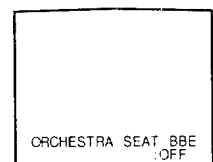
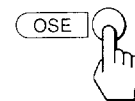

We recommend LOW setting for news programs and HIGH setting for music, sports, video games and movies. For the best sound quality, we recommend that AUDIO to be set at factory setting when OSE is set to ON.

- * Orchestra Seat™ Effect* (OSE) feature restores the harmonic balance of the sound to dramatically improve the overall reproduction of programs. Orchestra Seat™ Effect is using BBE technology under licence from BBE sound Inc.

Note

- OSE may also be output through audio out.

Listening with the cordless stereo headphones

Setting up the headphones

Install the supplied battery into the headphones.

(1) Open the battery compartment lid by pressing on the lid as illustrated.

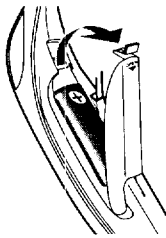

(2) Insert the size AA (R6) battery into the compartment with correct polarity and close the lid.

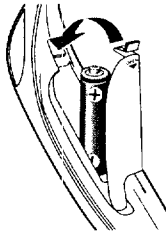

Battery life

When used continuously, the battery will last:
 — up to 40 hours with size AA (R6) alkaline batteries or
 — up to 20 hours with size AA (R6) manganese batteries.
 Replace the battery with a new one when the sound deteriorates.

Using the headphones

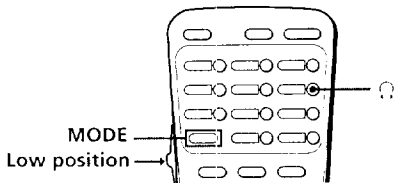

1 Press (headphones).

The display appears for about three seconds.

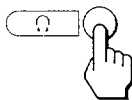

Selected channel number

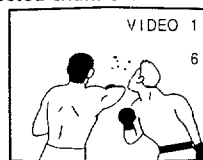

2 Turn on the headphones.

Turn the power on by adjusting the switch to ON. Adjust the volume with the switch located below the power switch.

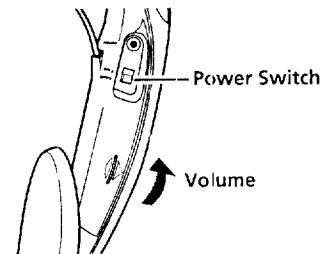

If you want to only listen to the sound from the cordless headphones, turn down the TV speaker volume or press MUTE.

To turn off the sound from the TV's speaker

Press VOL - until the sound disappears, or set SPEAKER to CENTER (see "Setting the speakers," page 24).

To turn off the headphones

Remove the headphones from your head, and turn the power switch to OFF, then press (headphones).

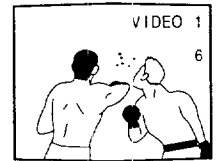
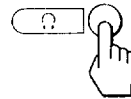

To improve sound reception

- Do not cover the infrared transmitter on the TV.
- Do not cover the infrared sensors on the headphones.

Infrared transmitter

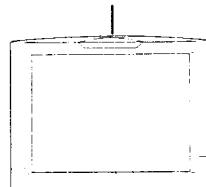

Infrared sensors

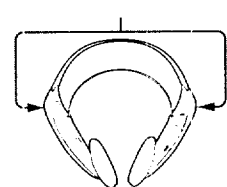

Notes

- The sound characteristics heard through the headphones cannot be modified in the same manner as the sound characteristics heard through the TV's speakers. Treble, bass and balance settings are fixed. Surround, OSE and muting features are not available.
- After you have finished listening with the headphones, it is recommended that you remove the headphones from your head before pressing (headphones). Otherwise noise will be heard through the headphones.
- To prevent hearing damage due to sudden or prolonged excessive volume, do not set the headphones' volume too high while listening.

Listening to sound from a main/right (PIP) and window/left (P&P) picture

Follow these instructions to select the audio source that you want to receive through the cordless headphones (main or window picture). If you want to listen to sound from the window picture, make sure that the sound from the window picture is being received.

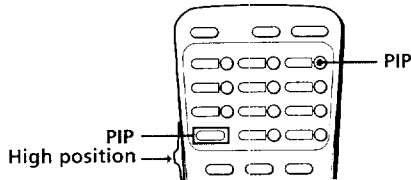

- 1 Press (PIP) or (P&P) to display a main/right or window/left picture.

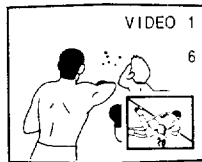
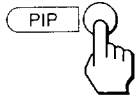

- 2 Press (headphones).

Each time you press (headphones), the audio source changes to main picture, window picture and "OFF" in sequence.

The display appears with the input mode.

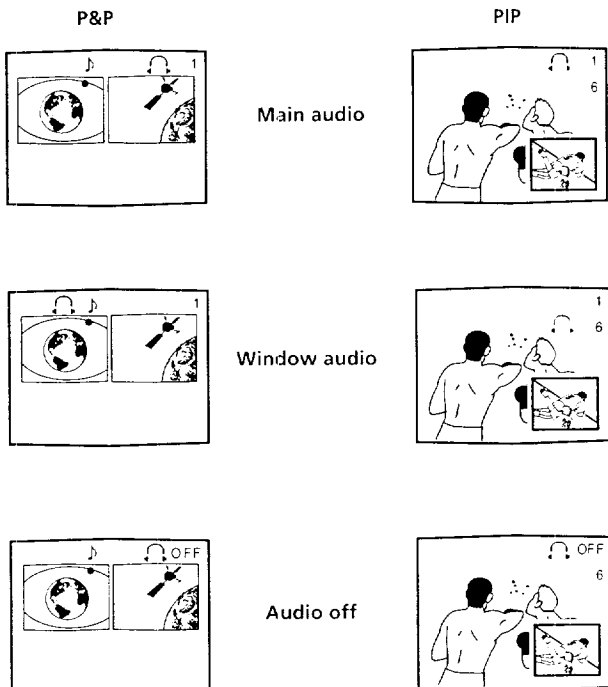

Notes

- If you turn the PIP or P&P function off, the sound from the cordless headphones changes to the main picture sound.
- If you turn the TV off, the next time you turn the TV on the headphones will be off.

Coverage area of the infrared rays

The diagrams illustrate the approximate area covered by the infrared rays emitted from the transmitter.

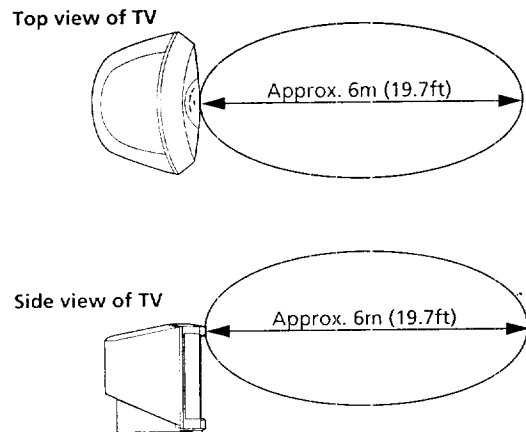

Note

- If you use the headphones at too great a distance from the transmitter, you may hear a hissing noise, and if there is an object between the headphones and the transmitter, the sound may be interrupted. These phenomena are inherent to infrared ray communication. They do not indicate a problem with the unit, itself.

Selecting the program palette mode

(PROGRAM PALETTE)

The PROGRAM PALETTE feature allows you to choose three different modes of picture settings. Choose the one that best suits the type of program that you want to watch.

1 Press MENU.

2 Press + ↑ or - ↓ to select PROGRAM PALETTE and press RETURN.

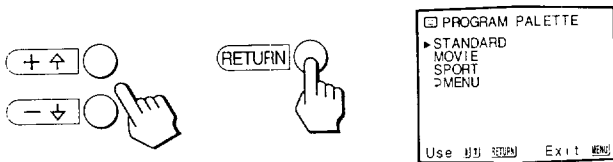

3 Press + ↑ or - ↓ to select STANDARD, MOVIE, or SPORTS mode and press RETURN.

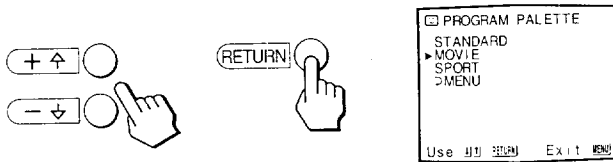

Choose	To
STANDARD	Receive a standard picture.
MOVIE	Receive a finely detailed picture.
SPORTS	Receive a vivid, bright picture.

Note

- The settings for these modes can be adjusted in the VIDEO menu. They will remain set unless the RESET button is pressed.

Setting daylight savings

(DAYLIGHT SAVING)

Activate DAYLIGHT SAVING if you are currently using Daylight Saving Time, or deactivate if you are using Standard Time. Using the DAYLIGHT SAVING feature will automatically adjust all time-related settings (CURRENT TIME, ON/OFF TIMER and CHANNEL BLOCK). DAYLIGHT SAVING should be set before using the CURRENT TIME SET functions (page 29).

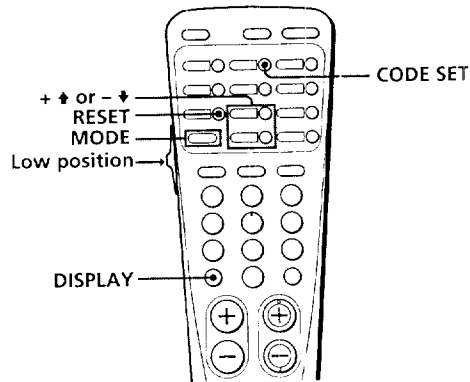

1 Press MENU.

2 Press + ↑ or - ↓ to select TIMER/CH BLOCK and press RETURN.

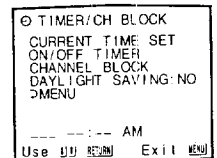

3 Press + ↑ or - ↓ to select DAYLIGHT SAVING and press RETURN.

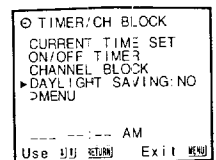

- 4** Press + ↑ or - ↓ to select YES or NO and press RETURN.

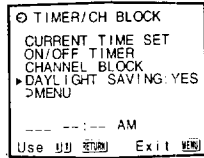
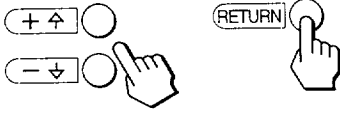

After the first Sunday in April:

Set to YES. Then, on the last Sunday in October, set to NO. All the time-related settings automatically move one hour back.

After the last Sunday in October:

Set to NO. Then, on the last Sunday in April, set to YES. All the time-related settings automatically move 1 hour ahead.

Setting the clock (CURRENT TIME SET)

Setting the clock enables you to turn the TV on and off with the timer, or to block a TV channel from being watched at a certain time.

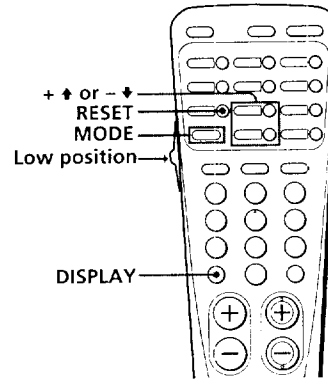

- 1** Press MENU.
- 2** Press + ↑ or - ↓ to select TIMER/CH BLOCK and press RETURN.



- 3** Make sure the cursor (▶) is beside CURRENT TIME SET and press RETURN.

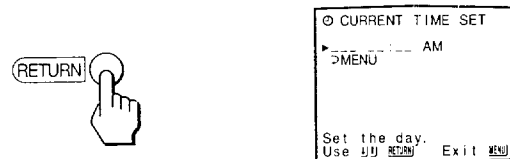

- 4** Press RETURN again to display default day and time.

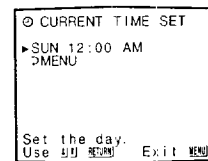

(continued)

5 Set the day:

(1) Press + ↑ or - ↓ to set the day and,

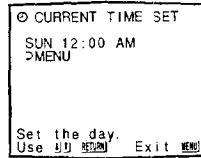
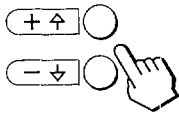

(2) press RETURN.

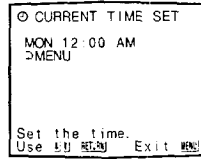

6 Set the time, hour and minutes in the same way you set the day.

When you press RETURN to set the minutes, the clock starts.

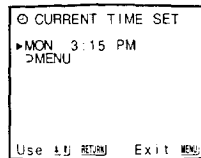
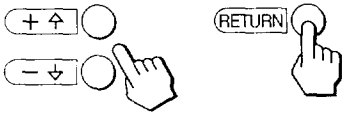

If you make a mistake while setting the time
Press RESET while the CURRENT TIME SET menu is displayed, then start again from step 4.

To display the time
Press DISPLAY.

Setting the timer to turn the TV on and off (ON/OFF TIMER)

You can set the TV to turn on and off at the time you specify. Make sure the clock is set correctly. If it is not, set the clock first (see page 29).

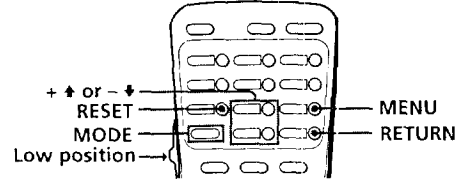

1 Press MENU.

2 Press + ↑ or - ↓ to select TIMER/CH BLOCK and press RETURN.

3 Press + ↑ or - ↓ to select ON/OFF TIMER and press RETURN.

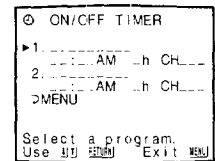

4 Press RETURN to display "EVERY SUN - SAT" default setting.

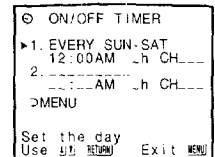

5 Press + ↑ or - ↓ to select the days you want and press RETURN.

Each time you press + ↑ or - ↓, the days cycle as shown in "Setting the day."

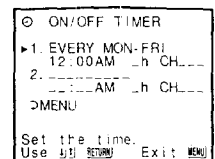
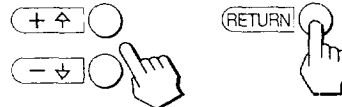

- 6 Press + ↑ or - ↓ to set the start time and press RETURN.**

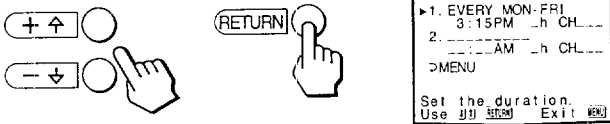

- 7 Press + ↑ or - ↓ to set the length of the program (1 to 6 hours) and press RETURN.**

For example, to have the TV turn off after 3 hours, set the duration to "3."

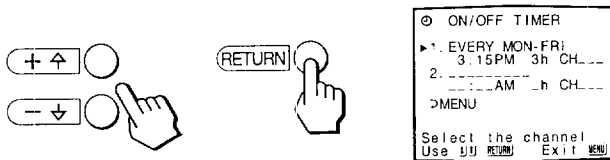

- 8 Press + ↑ or - ↓ to set the channel that you want to watch and press RETURN.**

When you press RETURN, the timer is set and the TIMER indicator on the front of the TV lights up.

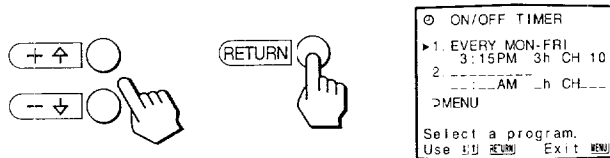

Repeat steps 4 - 7 to set the second timer.

When the time you set comes, the TV will turn on. (If the TV is already turned on, the TV screen changes to the channel you set.) Before the timer goes off, the message "TV will turn off" appears for one minute and then the TV turns off.

Setting the day

Each time you press + ↑, the days cycle as shown below. If you press - ↓, the days cycle in reverse order.



To change the timer setting

Set the new day and time following the procedure on the previous page. The previous setting is erased.

To cancel the timer

Select setting, press RETURN, and press RESET. The TIMER indicator on the front of the TV turns off.

Blocking out a channel (CHANNEL BLOCK)

You can lockout a channel that you don't want your children to watch. Make sure the clock is set correctly. If it is not, set the clock first (see page 29).

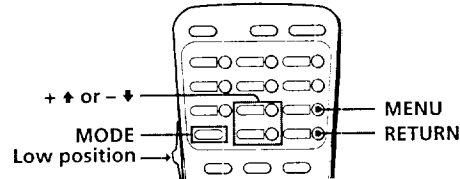

- 1 Press MENU.**
- 2 Press + ↑ or - ↓ to select TIMER/CH BLOCK and press RETURN.**
- 3 Press + ↑ or - ↓ to select CHANNEL BLOCK and press RETURN.**

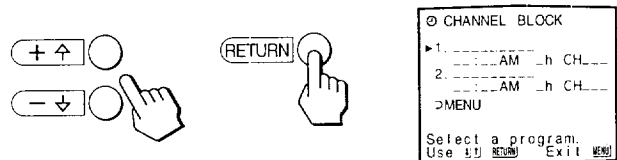

- 4 Press RETURN to display default setting "EVERY SUN - SAT".**



- 5 Press + ↑ or - ↓ to select the days you want to block the channel and press RETURN.**

Each time you press + ↑ or - ↓, the days cycle as shown in "Setting the day" on the previous page.



(continued)

6 Set the time that you want to start blocking the channel as you did the day.

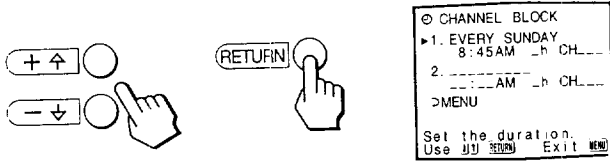

7 Press + ↑ or - ↓ to set the length of the program (1 to 12 hours) and press RETURN.

For example, to block a channel for 2 hours, set the duration to "2."

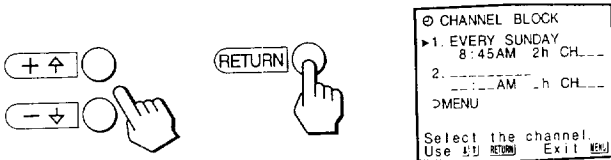

8 Press + ↑ or - ↓ to set the channel that you want to block and press RETURN.

When you press RETURN, the Channel Block setting is complete.

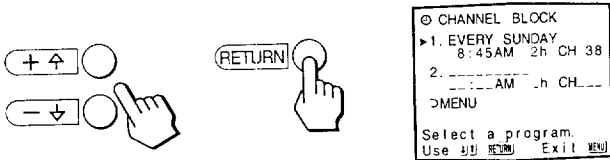

Repeat steps 4 - 7 to lockout a second channel.

If you select the blocked channel during the time you set, the message "BLOCKED" appears.

To cancel the Channel Block

Select setting, press ENTER, and press RETURN.

Setting up favorite channels (CHANNEL GUIDE)

You can choose up to 9 channels and assign a channel button 1-9 to each channel in the CHANNEL GUIDE. This feature allows you to select your favorite channels easily.

Setting up your favorite channels in the CHANNEL GUIDE

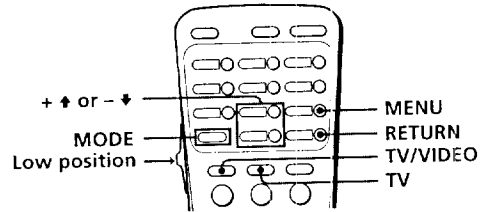

- 1 Press TV/VIDEO or TV to select TV mode.
- 2 Press MENU.
- 3 Press + ↑ or - ↓ to select SET UP and press RETURN.
- 4 Press + ↑ or - ↓ to select CHANNEL GUIDE and press RETURN.

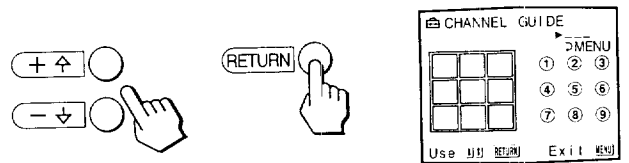

- 5 Press RETURN again to enter channel position mode.

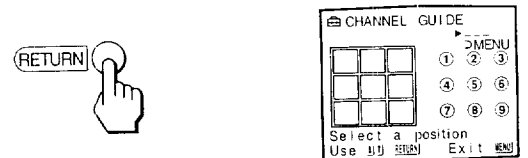

6 Press + ↑ or - ↓ to select a channel position and press RETURN.

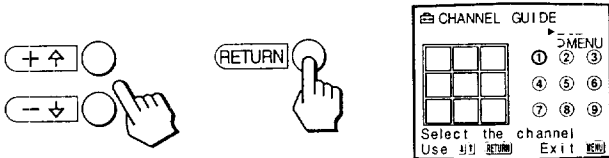

7 Press + ↑ or - ↓ to select the channel and press RETURN.

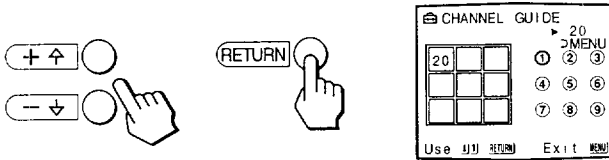

8 Repeat step 3 to 6 to select other channels.

Notes

- If the CHANNEL GUIDE menu appears in black, the TV is set to a video input and you cannot select CHANNEL GUIDE.
- If more than 90 seconds elapse after you press a button, the menu disappears automatically.
- The CHANNEL GUIDE feature is not available for the AUX input.

Selecting a favorite channel

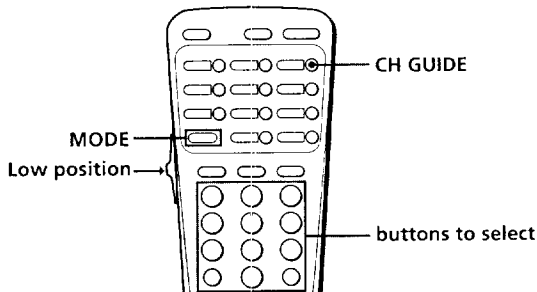

1 Press CH GUIDE.

The CHANNEL GUIDE menu appears showing channel screens and the corresponding channel number buttons.

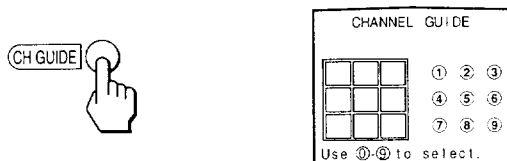

2 Press 1 – 9 buttons to select the channel you want.

To cancel the CHANNEL GUIDE menu

Press CH GUIDE again.

Note

- To reset CHANNEL GUIDE, go into the CHANNEL GUIDE menu as explained in "Setting up your favorite channels in the CHANNEL GUIDE" (page 32).

Setting captions to channels (CHANNEL CAPTION)

You can add a caption to a channel. For example, you can name channel 20 "ESPN".

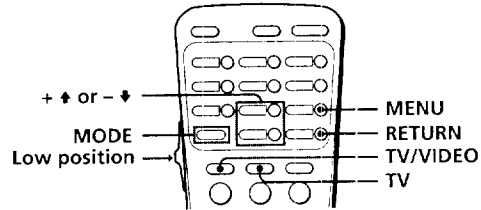

1 Press MENU.

2 Press + ↑ or - ↓ to select SETUP and press RETURN.

3 Press + ↑ or - ↓ to select CHANNEL CAPTION and press RETURN.

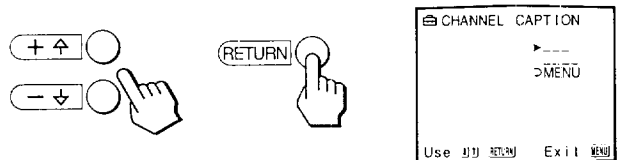

4 Press RETURN again.

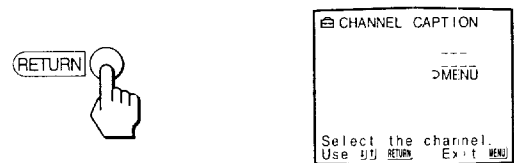

5 Press + ↑ or - ↓ to select the channel and press RETURN.

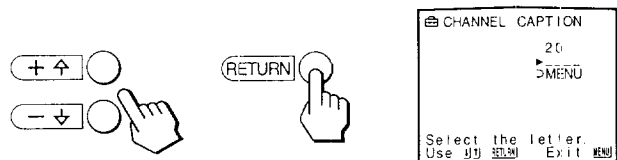

(continued)

6 Enter the letters (up to four) to caption the channel:

(1) Press + ↑ or - ↓ to display the first letter.

Each time you press + ↑ or - ↓, the letter changes as shown below and,

0 ↔ 1 ↔ ... ↔ 9 ↔ A ↔ E ↔ ... ↔ Z ↔ & ↔ / ↔ _ (blank space)

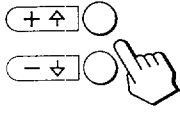

(2) press RETURN to select.

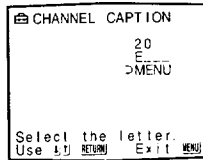
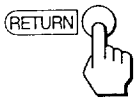

(3) Repeat steps (1) and (2) to select the remaining letters and press RETURN.

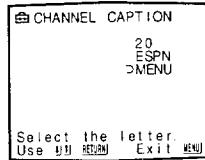
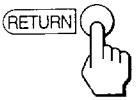

7 Repeat steps 4 to 6 to caption other channels.

To erase a caption

Press RESET after step 5.

Notes

- If the CHANNEL CAPTION menu appears in black, the TV is set to a video input and you cannot select CHANNEL CAPTION.
- If more than 90 seconds elapse after you press a button, the menu disappears automatically.
- The CHANNEL CAPTION feature is not available for the AUX input.

Setting video labels (VIDEO LABEL)

This feature allows you to label each video input mode so that you can easily identify the connected equipment. For example, you can label VIDEO 1 IN as VHS.

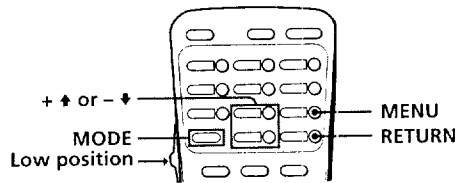

1 Press MENU.

2 Press + ↑ or - ↓ to select SET UP and press RETURN.

3 Press + ↑ or - ↓ to select VIDEO LABEL and press RETURN.

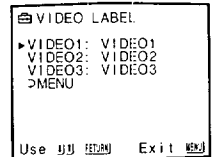
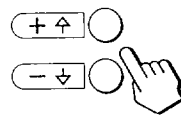

4 Press + ↑ or - ↓ to select the input mode you want to label and press RETURN.

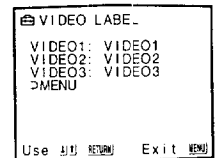
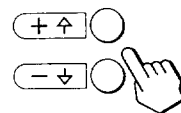

5 Press + ↑ or - ↓ to select the label and press RETURN.

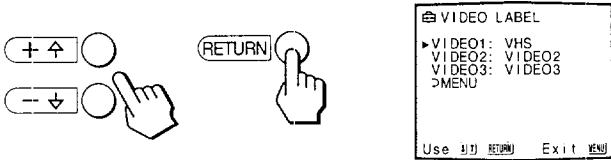

Each time you press + ↑ or - ↓, the label changes as shown below.

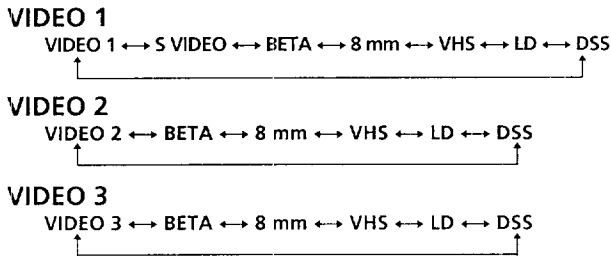

6 Repeat steps 4 and 5 to label other input modes.

Note

- If more than 90 seconds elapse after you press a button, the menu disappears automatically.

Selecting Caption Vision (CAPTION VISION)

Some programs are broadcast with Caption Vision. To set Caption Vision, select either CC1, CC2, CC3, CC4, TEXT1, TEXT2, TEXT3, or TEXT4 from the menu.

CC1, CC2, CC3, or CC4 shows you a caption, that is a printed version of the dialog or sound effects of a program. (The mode should be set to CC1 for most programs.)

TEXT1, TEXT2, TEXT3, or TEXT4 shows you text, that is information presented using half of the screen. It is not usually related to the program.

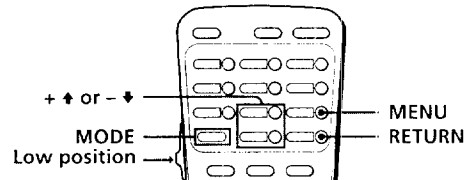

1 Press MENU.

2 Press + ↑ or - ↓ to select CAPTION VISION and press RETURN.

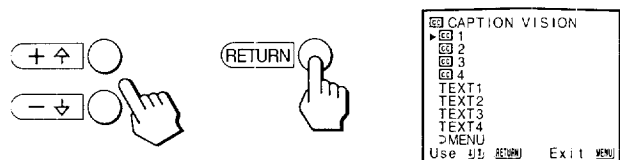

3 Press + ↑ or - ↓ to select the caption type and press RETURN.

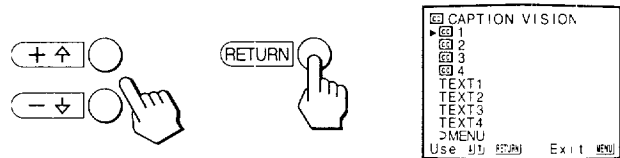

Notes

- To display captions, press DISPLAY button. Refer to page 17.
- Captions may appear with a white box or another error instead of a certain word. Poor reception of TV programs can also cause errors in Caption Vision.

Operating video equipment

You can operate video equipment that has an infrared remote sensor with the supplied remote control. To operate it, set the manufacturer's code number.

Setting the manufacturer's code

The following Sony video equipment is assigned to each position of the selector at its factory preset:

- VTR 1 Beta, ED Beta VCR
- VTR 2 8 mm VCR
- VTR 3 VHS VCR

You can change the settings of each position.

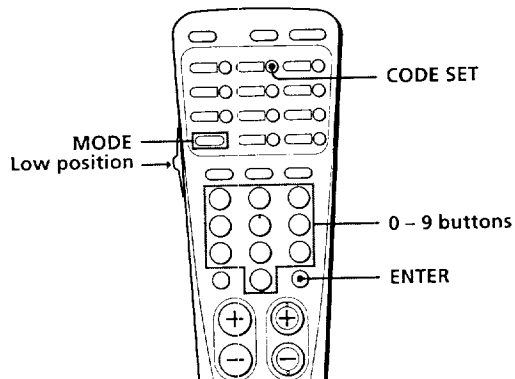

1 Set the VTR 1-2-3 selector to the position you want to set the code.

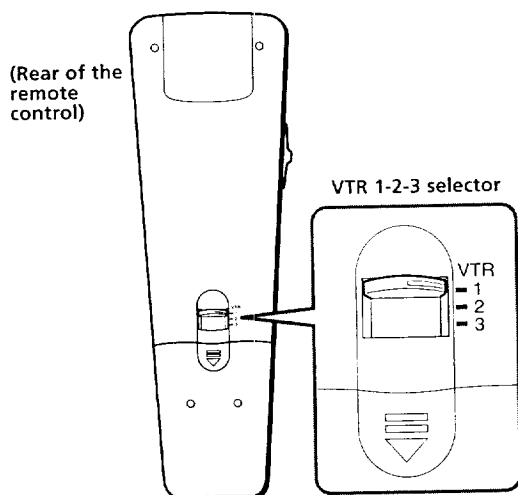

2 While pressing **CODE SET**, press **0-9** to enter the manufacturer's code number (see the chart in the column). For example, to operate a Sony 8 mm VCR, press **0, 2** and **ENTER**.

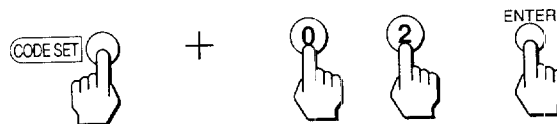

Note

- To use another manufacturer's equipment besides a Sony VCR, set the selector to a position not being used for your Sony video equipment.

VCR manufacturer code numbers

Manufacturer	Code number
SONY	01, 02, 03
CANON	05
EMERSON	22, 30, 33
FISHER	10, 11, 12, 15
FUNAI	29
GENERAL ELECTRIC	05, 08
GOLDSTAR	25
HITACHI	07, 08, 36
JVC	16, 35
MAGNAVOX	05, 06, 09
MITSUBISHI	18, 19, 26, 27
MULTITECH	29
NEC	16, 23, 31
PANASONIC	05, 06, 37
PHILCO	05, 06
PHILIPS	05, 06, 09
QUASAR	05, 06
RCA	07, 08
SAMSUNG	24, 32
SANYO	11, 15
SCOTT	21
SHARP	13, 14
SHINTOM	34
SYLVANIA	05, 06, 09
SYMPHONIC	29
TEKNIKA	28, 29
TOSHIBA	20, 21
TOTE VISION	25
ZENITH	17

MDP manufacturer code numbers

Manufacturer	Code number
SONY	04
KENWOOD	58
MAGNAVOX	52
MARANZ	54
MITSUBISHI	51
PANASONIC	55
PHILIPS	52
PIONEER	51
RCA	51
SANYO	57
SHARP	56
YAMAHA	53

Notes

- If more than one code number is listed, try entering them one by one, until you come to the correct code for your equipment.
- In some rare cases, you may not be able to operate your non-Sony video equipment with this remote control. This is because your equipment may use a code that is not provided with this remote control. In this case, please use the equipment's own remote control unit.
- The code numbers for Sony equipment are assigned at the factory as follows:
Beta, ED Beta VCR 01
8 mm VCR 02
VHS VCR 03

Caution

When you remove the battery from the remote control, the code may revert to the factory setting. Reset the code each time you replace the battery, if necessary.

Operating video equipment

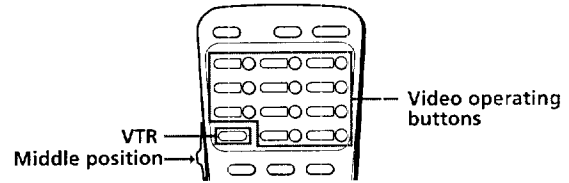

- 1 Set the VTR 1-2-3 selector according to the video equipment you want to operate.

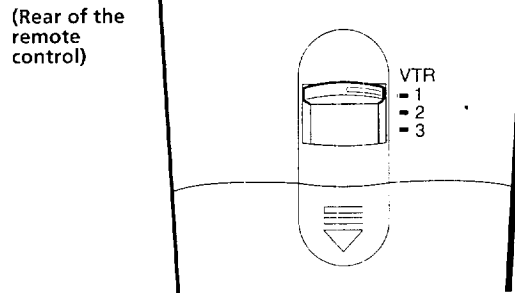

- 2 Use the video operating buttons on the remote control to operate the video equipment.

Operating a VCR	Buttons on the remote control
To turn on or off	Press POWER
To change channels	Press CH +/-
To record	Press ● and REC simultaneously
To play	Press ►
To stop	Press ■
To fast forward	Press ►►
To rewind the tape	Press ◄◄
To pause	Press To resume normal playback, press again
To search the picture forward and backward	Press ►► or ◄◄ during playback To resume normal playback, release the button.

Operating a multi-disc player	Buttons on the remote control
To play	Press ►
To stop	Press ■
To pause	Press To resume normal playback, press again.
To search the picture forward and backward	Keep pressing ►► or ◄◄ during playback To resume normal playback, release the button.
To search the chapter	Press CH +/-

Note

- If the video equipment does not have a certain function, the corresponding button on this remote control will not operate.

Operating a cable box

3 Use POWER(CABLE) and the TV control buttons (0 – 9, ENTER, JUMP and CH +/-) to operate the cable converter box.

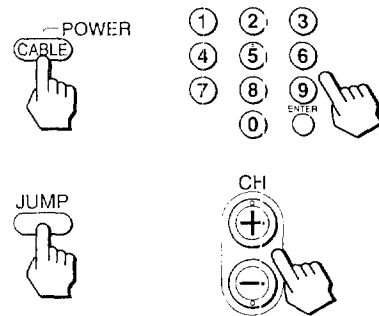

Setting the manufacturer's code

Follow these instructions to set the manufacturer's code which will enable you to operate a connected cable box with the pre-programmed remote control. For example, you can set the remote control to operate a connected Zenith cable box as follows:

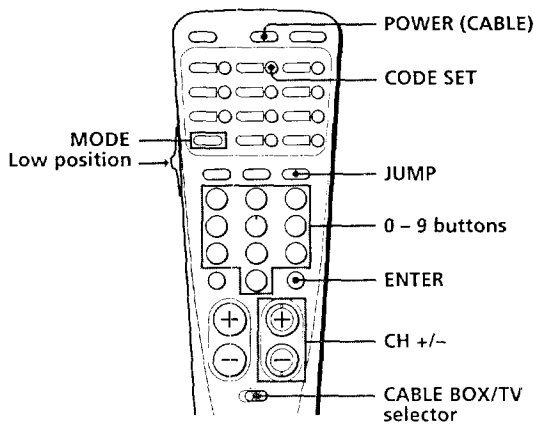

1 Set the CABLE BOX/TV selector to CABLE BOX.



2 While pressing CODE SET, press 6 and 8 (Zenith's code number —see chart on right) and ENTER.



To operate the TV

Set the CABLE BOX/TV selector to TV. Then use the TV control buttons to control the TV.

For more details on operating the cable box

Refer to the operating instructions that come with the cable box.

Manufactures and code numbers (cable box)

Manufacturer	Code number
JERROLD	60, 61, 62, 63, 64, 65, 73
PIONEER	69, 70
SCIENTIFIC ATLANTA	66, 67
TOCOM	71, 72
ZENITH	68

Notes

- If more than one code number is listed, try entering them one by one until you come up with the correct code for your equipment.
- If you enter a new code number, the code number you previously entered at that setting is erased.
- In some cases, your equipment may use a code that is not provided with this remote control and you may not be able to operate your cable box with the supplied remote control. In this case, use the equipment's own remote control unit.
- When you remove a battery from the remote control, the code may be erased. Reset the code each time you replace the battery, if necessary.
- The JUMP button may not work or cause another function in some cable boxes.

Auto cable input select function

This remote control also features a function that will switch automatically to your cable box TV input channel when you turn on the TV or cable box.

You can select 2–6 channels or VIDEO 1 depending on your cable box. For example, you can set the TV's channel to 3 whenever you turn the cable box on as follows:

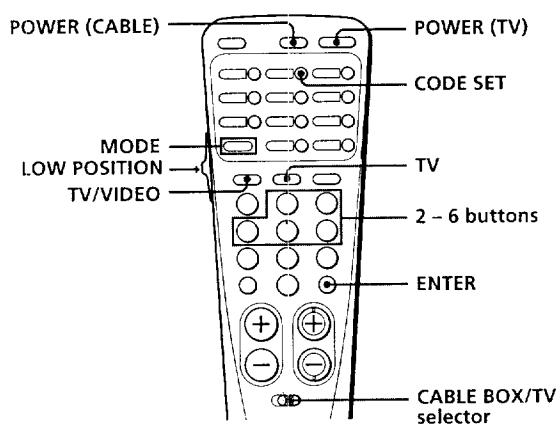

1 Set the CABLE BOX/TV selector to CABLE BOX.

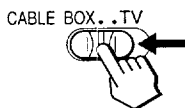

2 While pressing CODE SET, press POWER (CABLE), TV, 3 and ENTER.

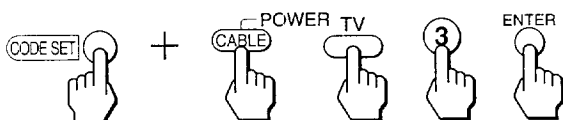

If you are viewing VIDEO 1 for cable TV, you can set as follows:

While pressing CODE SET, press POWER (CABLE), TV/VIDEO and ENTER.

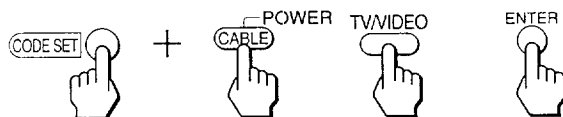

To reset the auto cable input select setting

While pressing CODE SET, press POWER (CABLE) and ENTER.

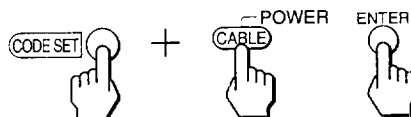

Notes

- In some cases, your cable box may use a code that is not provided with this remote control and you may not be able to operate your cable box with the supplied remote control.
- When you remove the battery from the remote control, the setting may be erased. Make the setting again each time you replace the battery, if necessary.
- If your TV's AC cord is plugged in to the cable box's switch outlet, it may effect the proper operation of this function.

Troubleshooting

After trying the methods below, if the problem persists, contact your nearest Sony dealer.

No picture (screen not lit), no sound

- Make sure the power cord is connected securely.
- Operate with the buttons on the TV.
- Check to see if the TV/VIDEO setting is correct: when watching TV, set to TV, and when watching video tapes, set to VIDEO.
- Try another channel. It could be station trouble.

Poor or no picture (screen lit), good sound

- Adjust PICTURE in the VIDEO menu. (page 20)
- Adjust BRIGHT in the VIDEO menu. (page 20)
- Check antenna/cable connections.
- Make sure S VIDEO is set to ON in the SET UP menu, when watching video tapes with an S video type VCR.

Good picture, no sound

- Press MUTING so that "MUTING" disappears from the screen. (page 17)
- Check the MTS setting in the AUDIO menu. (page 24)
- Make sure SPEAKER is set to ON in the AUDIO menu. (page 24)

No color

- Adjust COLOR in the VIDEO menu. (page 20)
- Black and white programs cannot be seen in color.

Only snow and noise appear on the screen

- Check the CABLE setting in the SET UP menu. (page 15)
- Check the antenna/cable connections.
- Make sure the channel is broadcasting programs.

Dotted lines or stripes

- Adjust the antenna.
- Move the TV away from noise sources such as cars, neon signs, and hair-dryers.

Double images or ghosts

- Use a highly directional outdoor antenna or a cable (when the problem is caused by reflections from nearby mountains or tall buildings).

Cannot operate menu

- If the item you want to choose appears in black, you cannot select it. Press TV/VIDEO until a channel number appears.

Cannot receive upper channels (UHF) when using an antenna

- Check if CABLE is OFF in the SET UP menu. (page 15)
- Use or AUTO PROGRAM to add receivable channels that are not presently in TV memory. (page 14)

Cannot receive any channels when using cable TV

- Check if CABLE is ON in the SET UP menu. (page 15)
- Use AUTO PROGRAM to add receivable channels that are not presently in TV memory. (page 14)

Remote control does not operate

- Battery could be weak. Replace the battery.
- Make sure the TV's power cord is connected securely to wall outlet.
- Set the CABLE BOX/TV selector to TV when operating your TV.
- Are fluorescent lights too close to TV? Move at least 3-4 feet away from TV.

Remote control's power, channel up/down, channel buttons do not function

- ➔ Set the CABLE BOX/TV selector to the correct position.

Cannot gain enough volume when using a cable box

- ➔ Increase the volume at the cable box. Then set the CABLE BOX/TV selector to TV and adjust the TV's volume.

The current time resets whenever the TV is turned on

- ➔ Connect the TV's and the cable box's AC power cord to separate wall outlets.

The TV needs to be cleaned

- ➔ Clean the TV with a soft dry cloth. Never use strong solvents such as thinner or benzine, which might damage the finish of the cabinet.

The TV always turns on to the same channel

- ➔ Check if you have preset your remote control for the AUTO cable input select function. If you do not want this feature, reset your remote control (page 39).

Specifications

	Model number	KV-27XBR45 KV-27XBR45M	KV-32XBR45	KV-32XBR85	Notes
Television system	American TV standard				
Channel coverage	VHF: 2-13 / UHF: 14-69 / CATV: 1-125				
Antenna	75-ohm external antenna terminal for VHF/UHF				
Picture tube	Hi Black Trinitron [®] tube	Trinitron [®] tube			
Screen size (in.)	27	32	32		Measured diagonally
Number of inputs/outputs	3	3	3		1 Vp-p, 75 ohms unbalanced, sync negative
Video					
S video	1	1	1		Y: 1 Vp-p, 75 ohms unbalanced, sync negative C: 0.286 Vp-p (Burst signal), 75 ohms
Audio	3	3	3		500 mVrms (100% modulation), Impedance: 47 kilohms
Audio out	1	1	1		More than 900 mVrms at the maximum volume setting (variable) More than 500 mVrms (fix) Impedance: 5 kilohms
Monitor out	1	1	1		Video (phone jack): 1 Vp-p, 75 ohm unbalanced, sync negative Audio (phone jack): 500 mVrms (100% modulation) Impedance: 10 kilohms
Loop out	1	1	1		
Control S (IN/OUT) mini jack	1	1	1		
Speaker output (W)	15 W × 2	15 W × 2	15 W × 2		7.5 ohms
Center speaker (W)	1	1	1		16 W (NOR), 16 ohms 30 W (MAX)
Power requirements	120 V 60 Hz	120 V 60 Hz	120 V 60 Hz		
Power consumption (W)					
When in use	185	195	* 195		
In standby	5	5	5		
Active super woofer	—	—	11		
Dimensions (W/H/D) (mm)	751.2 × 570.7 × 571.5 (29.6 × 22.5 × 22.5 in.)	850.4 × 645.8 × 617.5 (33.5 × 25.4 × 24.3 in.)	850.4 × 1144.6 × 698.9 (33.5 × 45.1 × 27.5 in.)		
Mass (kg)	53.7 (118.4 lbs)	71.1 (156.7 lbs)	90.6 (199.7 lb)		

Supplied accessories

Remote commander RM-Y127 (1)
Size AA (R6) battery (2)
Cordless stereo headphones MDR-IF120 (1)
RCA audio cable (KV-32XBR85)

* Not including super woofer

Optional accessories

U/V mixer EAC-66
Connecting cables VMC-810S/820S, VMC-720M, YC-15V/30V, RK-74A
TV stand SU-27XBR4 (KV-27XBR45 and 27XBR45M)
TV stand SU-32XBR4 (KV-32XBR45)

Design and specifications subject to change without notice.

Index

- Adjusting
 - picture 20
 - sound 22
 - Antenna 5
 - Auto Program 14
 - Auto cable input select function 39
 - Battery 12
 - Cable box 5
 - Caption Vision 35
 - Center Speaker 11
 - Channel Block 31
 - Channel Caption 33
 - Channel Guide 32
 - Connections
 - without a cable box 6
 - with a cable box 7
 - Jump 17
 - Listening
 - Surround 23
 - OSE (Orchestra Seat Effect) 25
 - Headphone 26
 - Muting 17
 - Operating
 - Video equipment 36
 - Cable box 38
 - Cable box input channel 39
 - VIDEO 1 MODE 39
 - Presetting channels 16
 - SAP (Second Audio Program) 24
 - Selecting
 - Menu language 16
 - MTS (Multichannel TV Sound) 24
 - Audio out 25
 - Setting
 - Daylight Saving 28
 - Program Palette 28
 - Remote Commander 12
 - Cable TV 15
 - Speaker 24
 - Clock (CURRENT TIME SET) 29
 - ON/OFF timer 30
 - Channel block 31
 - Video label 34
 - Sleep timer 18
 - Watching
 - TV 17
 - Video tapes 6
 - PIP 18
 - P&P 18
- ### Name of controls
- ↑ +/↓ - buttons 14
 - AUDIO button 12, 19
 - Cable Box/TV selector 38
 - CH (channel) GUIDE button 33
 - CH (channel) +/- button 14
 - CODE SET 36, 38
 - CONTROL S jack 11
 - DEMO button 14
 - DISPLAY button 17
 - ENTER button 17
 - FREEZE button 20
 - HEADPHONE button 26
 - JUMP button 17
 - MENU button 12, 14
 - MODE button 12
 - MONITOR OUT jacks 10
 - MUTING button 17
 - Number buttons (0 - 9) 14, 17
 - PIP button 18
 - PIP off 18
 - PIP size 18
 - P&P button 18
 - POSITION Button 19
 - POWER button 17
 - RESET button 21, 23
 - RETURN button 14, 15
 - S VIDEO input jack 6
 - SLEEP button 18
 - SWAP button 20
 - TV/VIDEO button 12, 16
 - VAR AUDIO OUT jacks 10
 - VCR 6, 7
 - VHF/UHF antenna terminal 5
 - VIDEO 1 IN jacks 6
 - VIDEO 2 INPUT jacks 8
 - VIDEO 3 IN jacks 8
 - VTR 1-2-3 Selector 12, 37
 - VOL (volume) +/- buttons 17



Trinitron® Color TV