

TV

Owner's

Guide

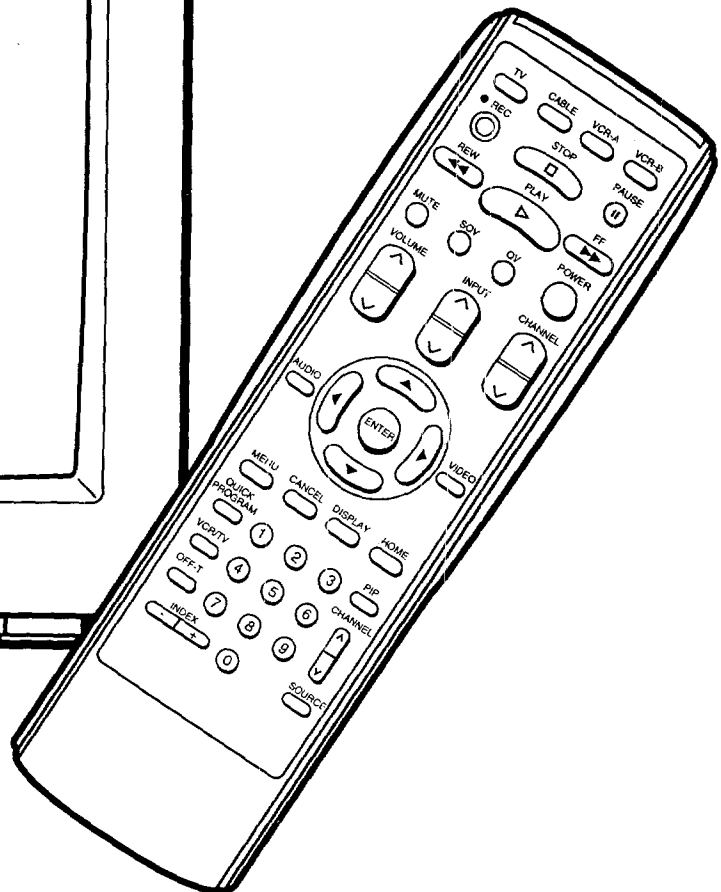

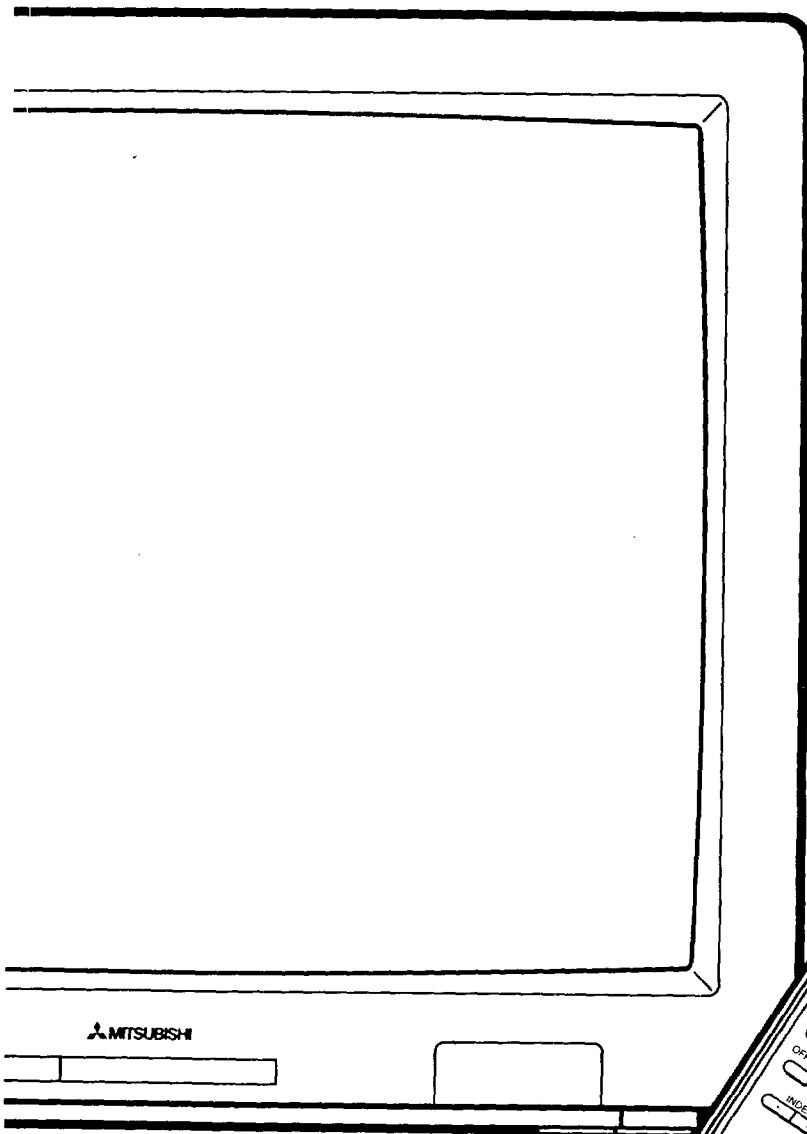
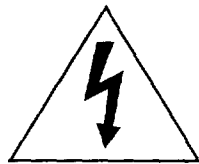
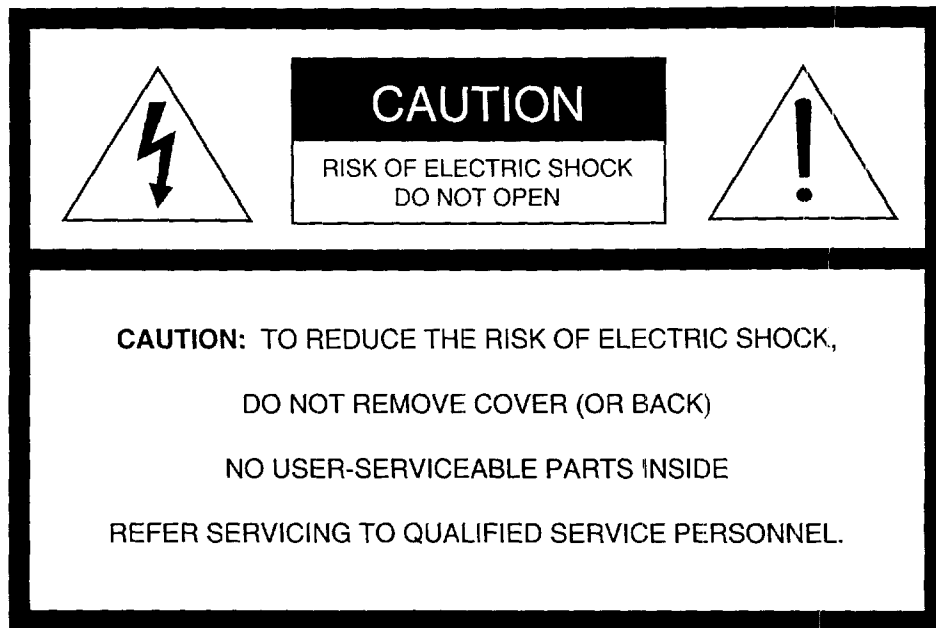

The lightning flash with arrowhead symbol, within an equilateral triangle, is intended to alert the user to the presence of uninsulated "dangerous voltage" within the product's enclosure that may be of sufficient magnitude to constitute a risk of electric shock.



The exclamation point within an equilateral triangle is intended to alert the user to the presence of important operating and maintenance (servicing) instructions in the literature accompanying the appliance.

WARNING:

TO PREVENT FIRE OR SHOCK HAZARD, DO NOT EXPOSE THIS APPLIANCE TO RAIN OR MOISTURE.

CAUTION:

TO PREVENT ELECTRIC SHOCK HAZARD, DO NOT USE THIS (POLARIZED) PLUG WITH AN EXTENSION CORD, RECEPTACLE OR OTHER OUTLET UNLESS THE BLADES CAN BE FULLY INSERTED TO PREVENT BLADE EXPOSURE.

NOTE TO CATV SYSTEM INSTALLER:

THIS REMINDER IS PROVIDED TO CALL THE CATV SYSTEM INSTALLER'S ATTENTION TO ARTICLE 820-40 OF THE NEC THAT PROVIDES GUIDELINES FOR PROPER GROUNDING AND, IN PARTICULAR, SPECIFIES THAT THE CABLE GROUND SHALL BE CONNECTED TO THE GROUNDING SYSTEM OF THE BUILDING, AS CLOSE TO THE POINT OF CABLE ENTRY AS PRACTICAL.

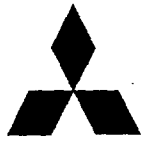

Table of Contents

Important Safeguards	3
Preface: Welcome to Mitsubishi	9
Summary of Special Features	10
Unpacking Your TV	11
What you'll find	11
A few suggestions	11
What's in Each Chapter	12
Some Conventions Used in this Guide	13
Chapter 1: Getting to Know Your TV	15
Overview of the Control Panel	16
Overview of the Remote Control	19
Getting ready to use the remote control	19
Remote control buttons and functions	21
Chapter 2: Connecting Your TV	25
Overview of the Back Panel	26
Basic Connections	28
TV+external speakers	29
TV+antenna or cable without a decoder box	30
TV+antenna or cable with a decoder box	31
TV+separate UHF and VHF antennas	33
TV+VCR+antenna or cable without a decoder box	34
TV+VCR+antenna or cable with a decoder box	37
TV+home theater receiver (A/V receiver)	40
TV+audio system	42
TV+Mitsubishi products that have A/V Network terminals	43
Chapter 3: Operating Your TV	45
Getting Started	46
Adjusting the color purity	47
Using the remote control	48

Getting Started (cont.)	
Turning the TV on/off	52
Selecting the input source	53
Changing channels	54
Understanding the on-screen menus	57
Setting the clock	58
Memorizing channels	60
Adding and deleting channels	61
Setting the A/V Network	62
Renaming the inputs	63
Selecting the on-screen language	64
Using video mute	65
Using the power restore feature	66
Using the advanced PIP functions	67
Adjusting the sound	68
Adjusting the picture	70
Using the closed caption decoder	72
Using the Advanced Features	73
Setting the timer	74
Using the parental lock	75
Using the Super Quick View tuning	77
Chapter 4: Using the Special Features	79
Understanding the On-Screen Displays	80
Using the Off-Timer	81
Setting the off-timer	82
Changing or canceling the off-timer	83
Using the Picture-in-Picture (PIP) Mode	84
Selecting the PIP image	85
Selecting the source	86
Selecting the channel	86
Exchanging the PIP image	87
Moving the PIP image	87
Freezing the PIP image	88
Using the Snap-shot feature	89
Using the Replay feature	90
Using the Active A/V Network Feature	91
Chapter 5: Troubleshooting.....	95
Caution and Care	98
Calling for Service	99
Appendix: Automatic Procedure for the Parental Lock.....	100
Index	101
Warranty	103

IMPORTANT SAFEGUARDS

PLEASE READ ALL THESE INSTRUCTIONS REGARDING YOUR TELEVISION SET AND RETAIN FOR FUTURE REFERENCES. FOLLOW ALL WARNINGS AND INSTRUCTIONS MARKED ON THE TV RECEIVER.

1. **Read Instructions**
All the safety and operating instructions should be read before the appliance is operated.
2. **Retain Instructions**
The safety and operating instructions should be retained for future reference.
3. **Heed Warnings**
All warnings on the appliance and in the operating instructions should be adhered to.
4. **Follow Instructions**
All operating and use instructions should be followed.
5. **Cleaning**
Unplug this TV receiver from the wall outlet before cleaning. Do not use liquid or aerosol cleaners. Use a damp cloth for cleaning.
6. **Attachment and Equipment**
Never add any attachments and/or equipment without approval of the manufacturer as such additions may result in the risk of fire, electric shock or other personal injury.
7. **Water and Moisture**
Do not use this TV receiver where contact with or immersion in water is a possibility. Do not use near: bath tubs, wash bowls, kitchen sinks, laundry tubs, or swimming pools, etc.

► Warning:

Don't leave stationary images, such as those generated from stock market reports or video games, on-screen for more than 10 minutes. Still patterns can scar the TV causing permanent damage to the picture tube.

8. Accessories

Do not place this TV receiver on an unstable cart, stand, tripod, bracket, or table. The TV receiver may fall, causing serious injury to a child or adult, and serious damage to the appliance. Use only with a cart, stand, tripod bracket, or table recommended by the manufacturer, or sold with the TV receiver. Any mounting of the appliance should follow the manufacturer's instructions, and should use a mounting accessory recommended by the manufacturer.

An appliance and cart combination should be moved with care. Quick stops, excessive force, and uneven surfaces may cause the appliance and cart combination to overturn.



S 3126 A

9. Ventilation

Slots and openings in the cabinet are provided for ventilation and to ensure reliable operation of the TV receiver and to protect it from overheating. Do not block these openings or allow them to be blocked by placing the TV receiver on a bed, sofa, rug, or other similar surface. Nor should it be placed over a radiator or heat register. If the TV receiver is to be placed in a rack or bookcase, ensure that there is adequate ventilation and that the manufacturer's instructions have been adhered to.

10. **Power Sources**
This TV receiver should be operated only from the type of power source indicated on the marking label. If you are not sure of the type of power supply to your home, consult your appliance dealer or local power company.
11. **Grounding or Polarization**
For your safety, this TV receiver is equipped with a polarized alternating current line plug having one blade wider than the other. This plug will fit into the power outlet only one way. If you are unable to insert the plug fully into the outlet. Try reversing the plug. If the plug should still fail to fit, contact your electrician to replace your obsolete outlet. Do not defeat the safety purpose of polarized plug.
12. **Power-Cord Protection**
Power-supply cords should be routed so that they are not likely to be walked on or pinched by items placed upon or against them, paying particular attention to cords at plugs, convenience receptacles, and the point where they exit from the appliance.
13. **Lightning**
For added protection for this TV receiver during a lightning storm, or when it is left unattended and unused for long periods of time, unplug it from the wall outlet and disconnect the antenna or cable system. This will prevent damage to the video product due to lightning and power-line surges.
14. **Power Lines**
An outside antenna system should not be located in the vicinity of overhead power lines or other electric light or power circuits, or where it can fall into such power lines or circuits. When installing an outside antenna system, extreme care should be taken to keep from touching such power lines or circuits as contact with them might be fatal.

15. **Overloading**
Do not overload wall outlet and extension cords as this can result in a risk of fire or electric shock.
16. **Object and Liquid Entry**
Never push objects of any kind into this TV receiver through openings as they may touch dangerous voltage points or short-out parts that could result in a fire or electric shock. Never spill liquid of any kind on the TV receiver.
17. **Outdoor Antenna Grounding**
If an outside antenna or cable system is connected to the TV receiver, be sure the antenna or cable system is grounded so as to provide some protection against voltage surges and built-up static charges.

Section 810 of the National Electrical Code, ANSI/NFPA No.70-1984, provides information with respect to proper grounding of the mast and supporting structure, grounding of the lead-in wire to an antenna discharge unit, size of grounding conductors, location of antenna-discharge unit, connection to grounding electrodes, and requirements for the grounding electrode.

**EXAMPLE OF ANTENNA GROUNDING
AS PER NATIONAL ELECTRICAL CODE**

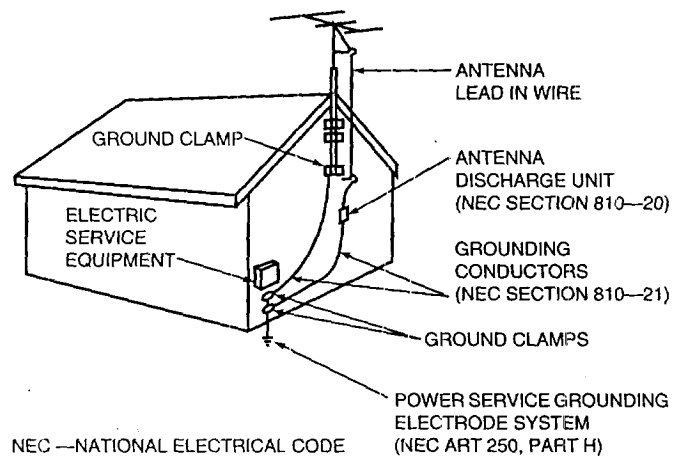

18. **Servicing**
Do not attempt to service this TV receiver yourself as opening or removing covers may expose you to dangerous voltage or other hazards. Refer all servicing to qualified service personnel.
19. **Damage Requiring Service**
Unplug this TV receiver from the wall outlet and refer servicing to qualified service personnel under the following conditions :
 - (a) When the power-supply cord or plug is damaged.
 - (b) If liquid has been spilled, or objects have fallen into the TV receiver.
 - (c) If the TV receiver has been exposed to rain or water.
 - (d) If the TV receiver does not operate normally by following the operating instructions. Adjust only those controls that are covered by the operating instructions as an improper adjustment of other controls may result in damage and will often require extensive work by a qualified technician to restore the TV receiver to its normal operation.
 - (e) If the TV receiver has been dropped or the cabinet has been damaged.
 - (f) When the TV receiver exhibits a distinct change in performance - this indicates a need for service.
20. **Replacement Parts**
When replacement parts are required, be sure the service technician has used replacement parts specified by the manufacturer or have the same characteristics as the original part. Unauthorized substitutions may result in fire, electric shock or other hazards.
21. **Safety Check**
Upon completion of any service or repairs to this TV receiver ask the service technician to perform safety checks to determine that the TV receiver is in a safe operating condition.



PREFACE

Welcome to Mitsubishi

Congratulations on your purchase of your new CS-40503 Mitsubishi TV. Your TV is designed for superb viewing pleasure as well as continued reliability.

To familiarize you with your TV and owner's guide, we suggest that you read through the preface, which provides the following important information:

- ◆ **Summary of Special Features**
- ◆ **Unpacking Your TV**
- ◆ **What's in Each Chapter**
- ◆ **Some Conventions Used in This Guide**

Mitsubishi has strived to create your TV so that it will bring you years of viewing enjoyment. Similarly, your owner's guide is designed with a "user friendly" philosophy that will help you take advantage of all of your equipment's features.

Once again, thank you for selecting our product and welcome to Mitsubishi!

◆ Summary of Special Features

Your top rated Mitsubishi TV delivers:

- **181-Channel Capacity** --- programs up to 181 channels, ensuring your continued viewing pleasure as cable services continue to expand.
- **Two-Speaker Sound System** --- a special, speaker system that produces clear, stereo sound.
- **Expanded Sound Capability** --- allows you to connect the TV to an external audio system for enhanced listening pleasure.

In addition to the standard features found on most advanced TVs, Mitsubishi is proud to offer the following distinctive features:

- **Remote Control with TV/VCR/CABLE Function** --- uses a single remote control transmitter for the television, certain Mitsubishi VCRs, audio components and also some VCRs and cable boxes of other manufacturers.
- **On-Screen Displays** --- appear whenever you adjust your TV, showing you the status of your TV's various functions.
- **On-Screen Menu** --- simplifies the television's features with easy to follow instructions.
- **Closed Caption Decoder** --- supplies you the text information along with the regular broadcasts.
- **Extended Data Services** --- (also known as "EDS,") allows broadcasters to supply you with the time of day, channel information, and program information. You can display this information on-screen.
- **Picture-in-Picture Mode** --- allows you to view two different sources at the same time.
- **Active A/V Network** --- allows you to perform many of the commonly used features of your system at the press of just one button.

Each of these features will be explained in more detail in Chapter 3, "Operating Your TV," and Chapter 4, "Using the Special Features."

◆ Unpacking Your TV

What you will find

As you unpack your new TV, please check to be sure that along with the TV, the following items are included:

- an owner's guide that includes a warranty,
- a registration card,
- a remote control transmitter,
- a set of two AA size batteries for the remote control, and
- an A/V network cable.

A few suggestions

Before you hook up your new TV, please take a few minutes to:

- ❶ Complete the registration card. The registration card asks for the TV's serial number, which you'll find on the back of the unit.
- ❷ Keep the box and packing materials for future use.
- ❸ File your sales receipt.
- ❹ Place the TV on a stable surface with sufficient lighting to do the hook-up.

◆ What's in Each Chapter

Here's what you will find in this owner's guide:

Chapter 1, "Getting to Know Your TV," introduces you to the location and functions of the buttons and controls of your TV.

Chapter 2, "Connecting Your TV," explains how to connect a VCR, antenna, cable decoder, and other equipment to your TV.

Chapter 3, "Operating Your TV," provides the step-by-step instructions you need in order to use your TV.

Chapter 4, "Using the Special Features," explains how to use some of the special features of the TV.

Chapter 5, "Troubleshooting," summarizes the problems you may have along with the suggestions for solving these problems.

The appendix explains an automatic procedure for the parental lock.

You'll also find a detailed index at the back of the book.

◆ Some Conventions Used in this Guide

Mitsubishi has gone to great effort to provide users with an easy-to-follow, useful owner's guide. Different types of information is treated in different ways.

Users should read information labelled **Important** and information which is boxed and labelled **Warning**. The owner's guide uses these terms sparingly, and all information highlighted in this manner should be read carefully.

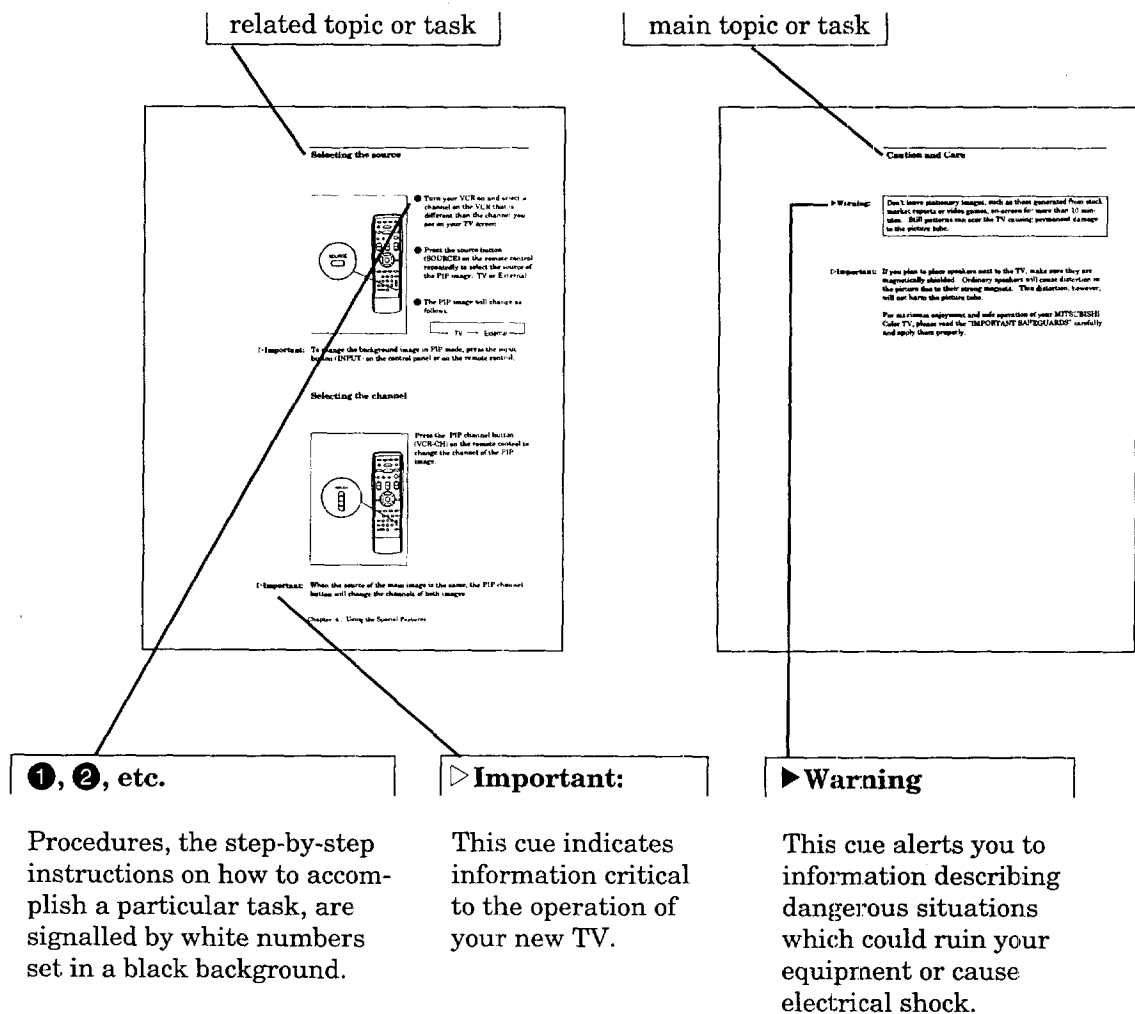

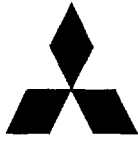

Getting to Know Your TV

Now that you've unpacked your TV, read through the safety information, and glanced at the overview explaining how this owner's guide is organized, it's time to become familiar with the buttons and controls you'll be using when you operate the TV. This chapter will introduce the range of options available by using the buttons on the control panel of the TV or the remote control. It also offers some general guidelines for using the remote control.

Most functions can be controlled by using either the control panel or the remote control, but certain specialized functions require you use to one or the other. This chapter, which will familiarize you with the full range of button functions, contains the following sections:

- ◆ **Overview of the Control Panel**
- ◆ **Overview of the Remote Control**

◆ Overview of the Control Panel

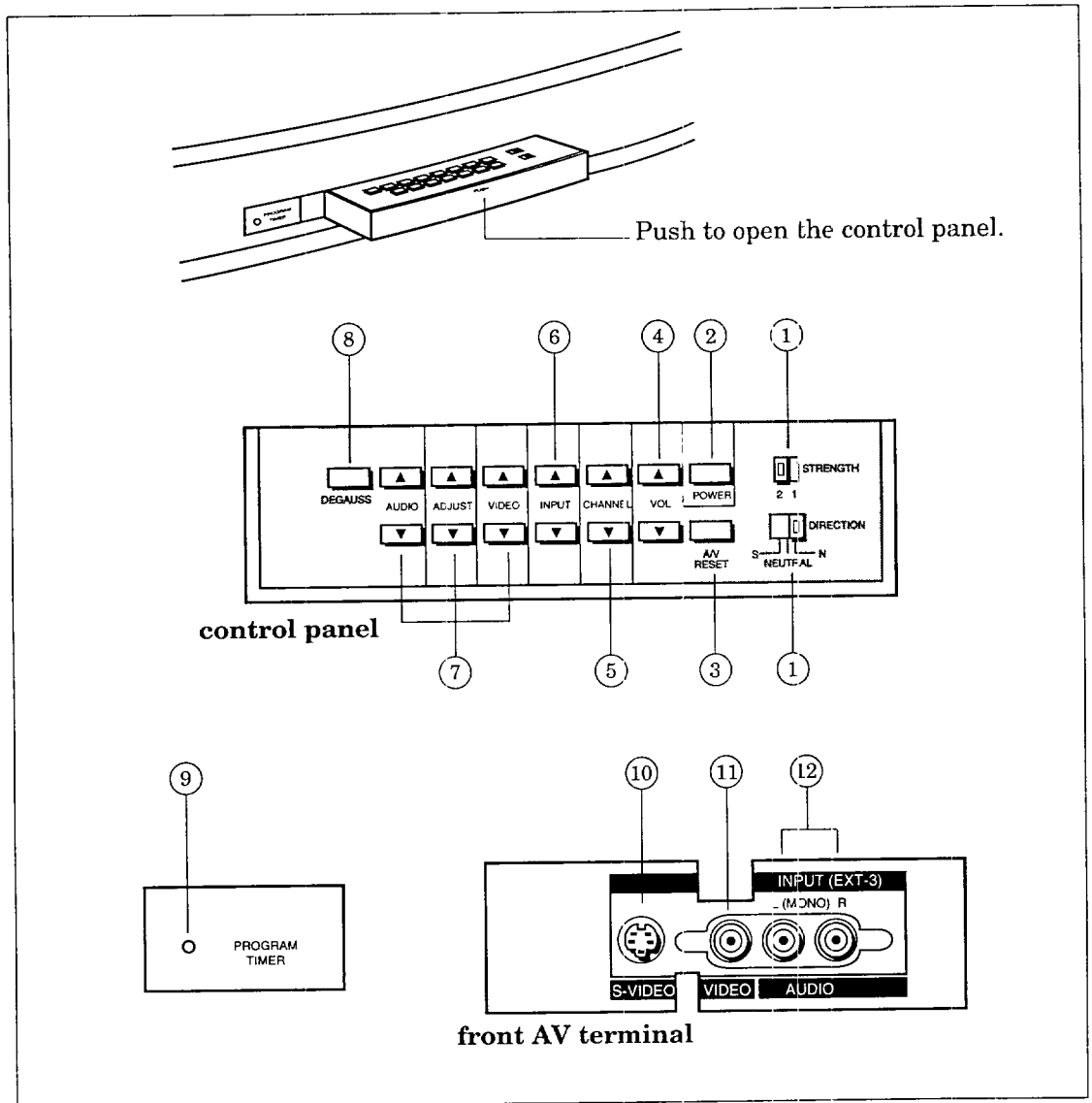

① **color purity adjustment switches**
Set to the suitable position.

② **power button (POWER)**
Use to turn the TV on or off.

③ **A/V reset button (A/V RESET)**
Press to reset all audio and video functions to their normal level or setting, except for volume, reception mode (Stereo/SAP/Mono), speaker (internal/external), monitor out (variable/fixed) and closed captioning.

④ **volume controls (VOL)**

Press the ▲ button to turn up the volume and the ▼ button to turn down the volume.

⑤ **channel controls (CHANNEL)**

Use the ▲ button to switch to a channel with a higher number and the ▼ button to switch to a channel with a lower number.

⑥ **input button (INPUT)**

Use either button to select the input source to be viewed:

- Antenna A,
- Antenna B, or
- External 1, 2 or 3.

⑦ **audio and video controls**

These buttons are used in pairs to adjust features of the image or sound (other than volume) with a two-step process: using one of the audio or video buttons to select a function, and then using the adjust button.

- **audio function button (AUDIO)**---Use to select one of the following audio functions:
 - stereo/SAP/mono,
 - bass,
 - treble,
 - balance,
 - audio expansion,
 - level sound on/off,
 - speaker internal/external, or
 - monitor out variable/fixed.
- **video function button (VIDEO)**---Use to select one of the following video functions:
 - tint,
 - color,
 - contrast,
 - brightness,
 - sharpness,
 - video noise reduction on/off,
 - color temperature low/middle/high,
 - color bias average/accurate/skin-tone, or
 - closed captioning.
- **adjust buttons (ADJUST)**---After selecting the audio or video function, use either the up or the down button to adjust the function you've selected. These buttons can be used to:
 - turn the function on or off (e.g., video noise reduction),
 - increase or decrease the function (e.g., color),
 - shift from one end of a scale to the other (e.g., balance), or
 - select a position (e.g., stereo).

The adjust buttons are also used to select an item from the on-screen menu.

Overview of the control panel (cont.)

- ⑧ **degauss button (DEGAUSS)**
Use this button to correct color impurity.
- ⑨ **program timer indicator (PROGRAM TIMER)**
Lights up when the TV is programmed to turn on at a particular time.
- ⑩ **S-VIDEO input terminal**
Use to connect the video output of a Super VHS (S-VHS) VCR to the TV. If you connect a S-VHS VCR to this terminal, EXT-3 will automatically be the input for viewing the S-VHS VCR.
- ⑪ **video input terminal**
Use to connect the video output from a standard VCR or another component to the TV
- ⑫ **audio input terminals**
Use to connect the audio from a VCR or other equipment.

◆ Overview of the Remote Control

Getting ready to use the remote control

installing the batteries

- ❶ Take the box containing two AA size batteries from the packing bag.
- ❷ Remove the back cover of the remote control by pushing in the direction of the arrow.
- ❸ Load the batteries as indicated in the illustration, making sure that they are positioned correctly (+ to +, and - to -).
- ❹ Replace the back cover of the remote control.

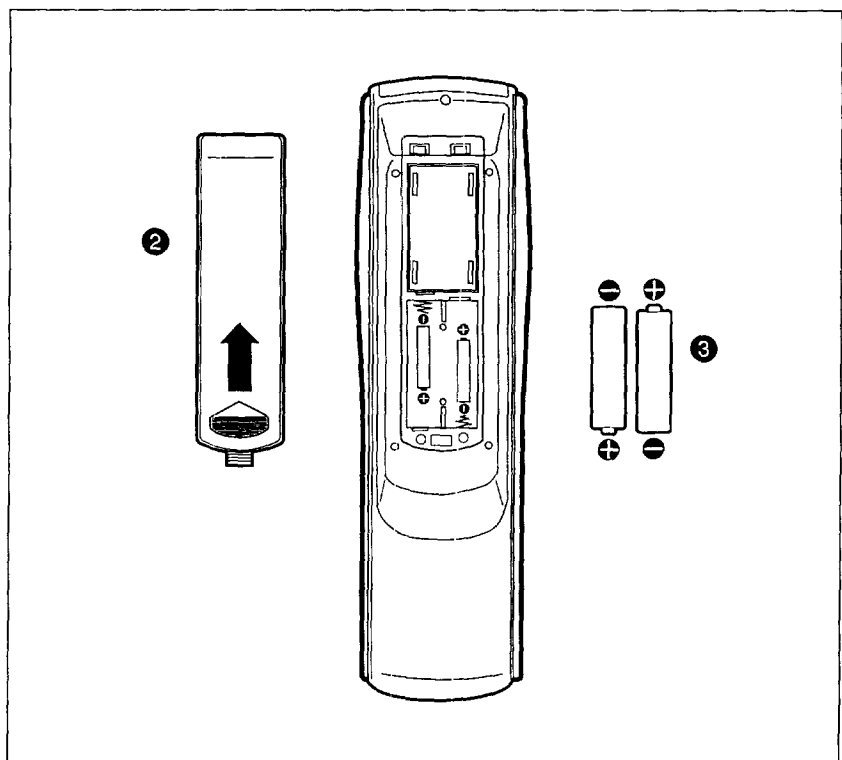

For best results, use Duracell AA (MN1500) batteries.

Overview of the remote control (cont.)

some dos and don'ts

To ensure that your remote control will continue working properly, follow these guidelines:

- Don't press two or more buttons at the same time.
- Don't allow the remote control to get wet or become heated.
- Avoid dropping the remote control on a hard surface.
- When cleaning the remote control, don't use any harsh chemicals. Use only a soft, slightly moistened cloth.

general instructions

When using the remote control to operate the TV, VCR or cable box, follow these procedures:

- ❶ Be within 20 feet of the desired equipment.
- ❷ Point the top of the remote control toward the equipment.
- ❸ Press the appropriate button or groups of buttons.

guidelines for using batteries

- Don't use a new battery with an old one.
- Don't heat, take apart, or throw batteries into a fire.

The following section explains more about the range of options available by using the remote control.

Remote control buttons and functions

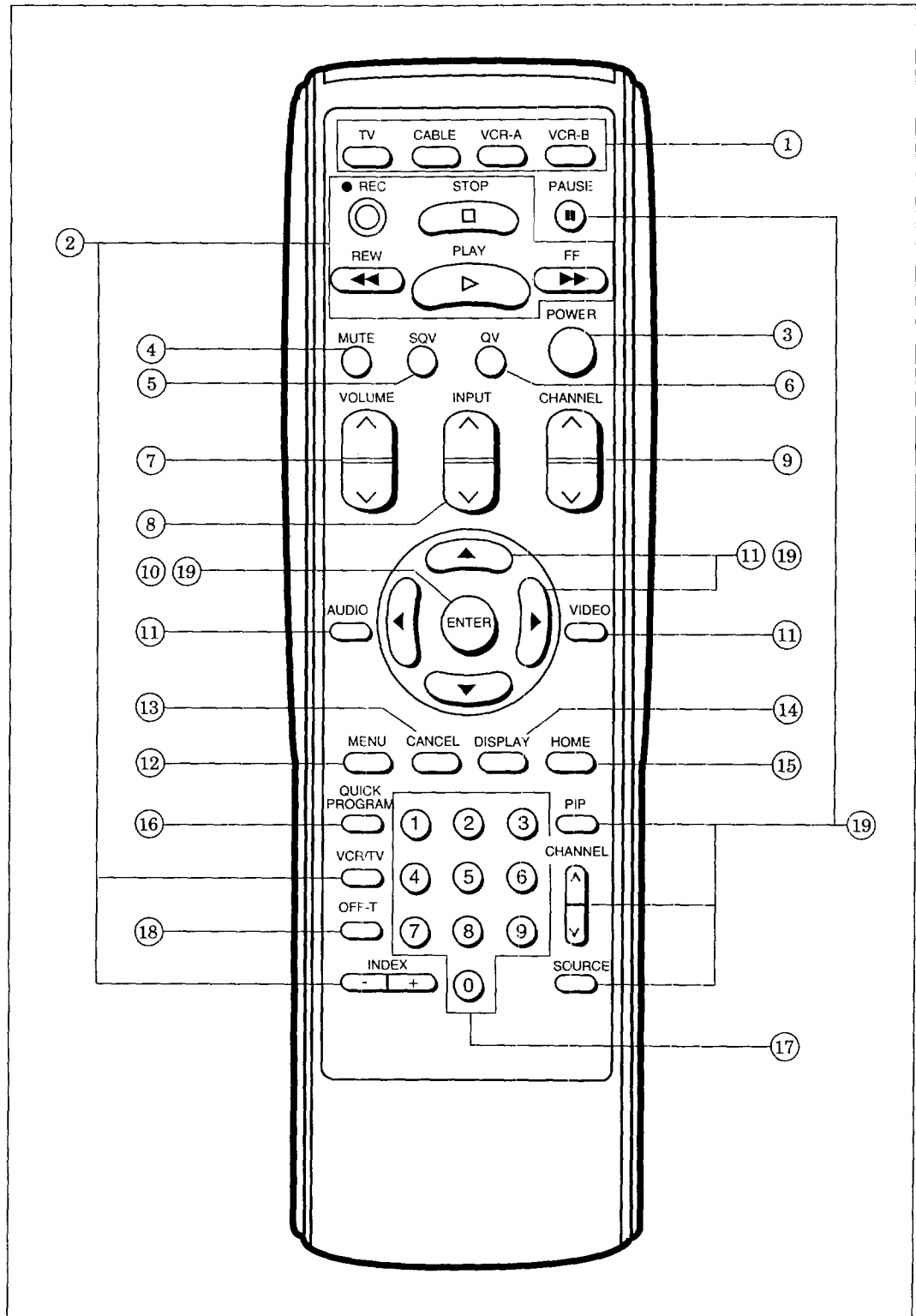

Overview of the Remote Control

Remote control buttons and functions (cont.)

- ① **select buttons**
Use these buttons to select the component you wish to operate: the TV, an audio component (in the CABLE layer), VCR-A or VCR-B. These are also used to set up your remote control for your particular brand of VCR.
- ② **audio and VCR buttons**
These buttons can be used to control VCRs, cassette decks, CD players, etc. These are pre-programmed to operate select Mitsubishi components. As for the PLAY button, see "Using the Active A/V Network Feature," page 91.
- ③ **power button (POWER)**
Use to turn the TV on or off.
- ④ **mute control (MUTE)**
Use to turn the sound off completely or restore it to its original volume.
- ⑤ **super quick view button (SQV)**
Press to view channels you have programmed into the super quick view memory.
- ⑥ **quick view button (QV)**
Press to switch to the channel you have stored into the quick view memory.
- ⑦ **volume control (VOLUME)**
Press the top part of the button to turn up the volume; press the bottom part of the button to turn down the volume.
- ⑧ **input button (INPUT)**
Use to select the input source you wish to watch:
 - Antenna A,
 - Antenna B, or
 - External 1, 2 or 3.
- ⑨ **channel control (CHANNEL)**
Press the top part of the button to change to a channel with a higher number; press the bottom part to change to a channel with a lower number.
- ⑩ **enter button (ENTER)**
May be used after selecting a channel number or an item from the on-screen menu system. Also use with the PIP function.
- ⑪ **audio and video controls**
These buttons are used in pairs to adjust features of the image or sound (other than volume) with a two-step process: using one of the audio or video buttons to select a function, and then using the adjust up/down button or right/left button.
 - **audio function button (AUDIO)**---Use to select one of the following audio functions:
 - stereo/SAP/mono,
 - bass,

- treble,
- balance,
- audio expansion,
- level sound on/off,
- speaker internal/external, or
- monitor out variable/fixed.

- **video function button (VIDEO)**---Use to select one of the following video functions:
 - tint,
 - color,
 - contrast,
 - brightness,
 - sharpness,
 - video noise reduction on/off,
 - color temperature low/middle/high,
 - color bias average/accurate/skin-tone, or
 - closed captioning.
- **adjust up/down buttons, right/left buttons**---After selecting the audio or video function, use either the up(right) or the down(left) button to adjust the function you've selected. These buttons can be used to:
 - turn the function on or off (e.g., video noise reduction),
 - increase or decrease the function (e.g., color),
 - shift from one end of a scale to the other (e.g., balance), or
 - select a position (e.g., stereo).

You will also use the adjust buttons to select items on the on-screen menus.

⑫ **menu button (MENU)**

Use this button to display the on-screen menu system, which contains additional instructions for special functions.

⑬ **cancel button (CANCEL)**

This button is used to cancel the entered channel number within three seconds, to erase the parental lock code during the parental lock sequence, to clear a channel programmed into super quick view memory, and to clear the settings of some on-screen menus.

⑭ **display button (DISPLAY)**

Use to view an on-screen summary of the current TV settings for TV or cable functions, and the display related to Television Data Services (TVDS).

⑮ **home button (HOME)**

Press to return to regular TV viewing from the on-screen displays and menus.

Remote control buttons and functions (cont.)

⑩ **quick program button (QUICK PROGRAM)**

Use this button to perform automated programming operations with both your TV and your Mitsubishi VCR. When you press this button, your TV will switch to the External-1 input, your VCR will turn on, and the VCR's "Program to record" menu will appear. When you are finished programming your VCR, press this button again; your VCR will turn off, and your TV will return to its previous position.

If you press this button while the TV is locked, or while using the television's menus, then the VCR will turn on, but the TV will not switch inputs.

Additionally, you must have connected your VCR with the A/V Network.

⑪ **number buttons (0-9)**

Use to select a channel number, and to enter the parental lock code.

⑫ **off-timer button (OFF-T)**

Use to program the TV to turn off automatically at a later time.

⑬ **picture-in-picture controls**

Use to control the special picture-in-picture (PIP) function.

- **PIP button (PIP)**---Press to see the reduced PIP image or cancel it. See "Using the Active A/V Network Feature," page 91.
- **channel button (CHANNEL)**---Press to change the channel of the reduced PIP image.
- **source button (SOURCE)**---Press repeatedly to switch the source of the reduced PIP image between the TV and the external inputs.
- **pause button (PAUSE)**---Press to freeze the reduced PIP image or cancel the image freezing. Also use for the advanced PIP functions.
- **enter button (ENTER)**---Press to switch back and forth between the reduced PIP image and the main image.
- **adjust up/down buttons, right/left buttons**---Press to move the position of the reduced PIP image.





CHAPTER 2

Connecting Your TV

This chapter offers step-by-step instructions for completing the most common hook-ups. It contains the following sections:

- ◆ **Overview of the Back Panel**
- ◆ **Basic Connections**

◆ Overview of the Back Panel

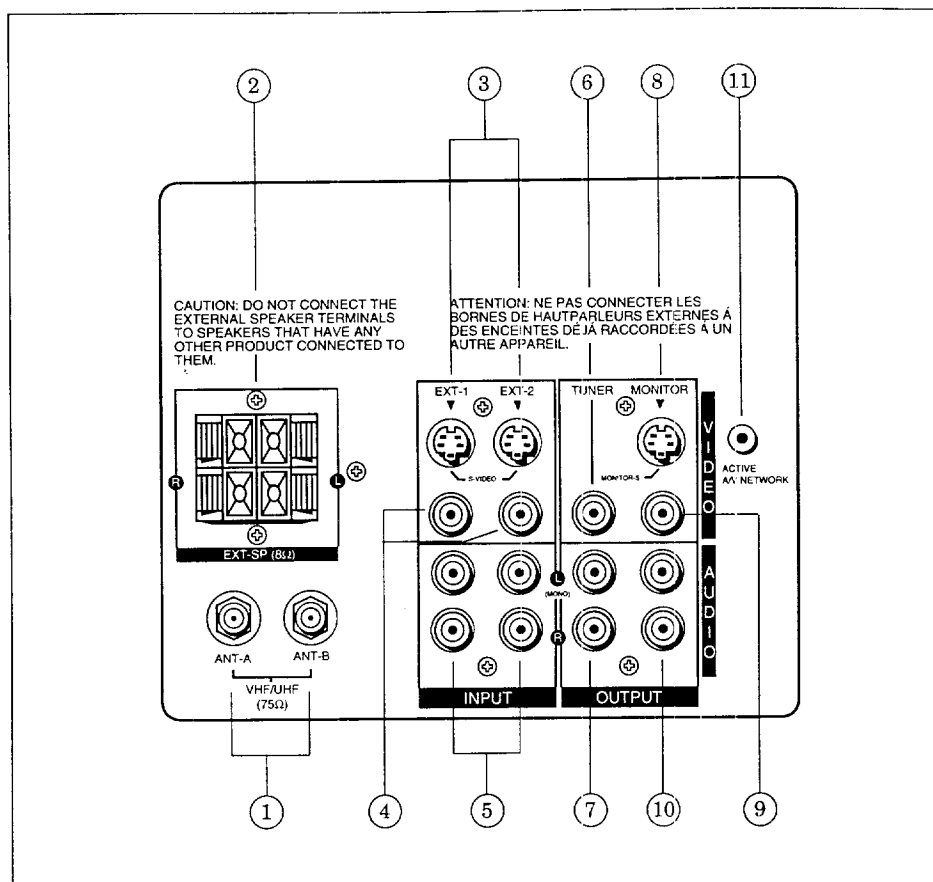

① **antenna terminals (ANT-A, ANT-B)**

Use to connect a VHF/UHF antennas.

② **external speaker terminals**

Use to connect external speakers. (Only use speakers with a nominal impedance of 8 ohms.)

► **Warning:**

Never connect equipment other than speakers to the external speaker terminals. Don't connect speakers that are already hooked up to an amplifier.

③ **S-VIDEO input terminals**

Use to connect the video out of a Super VHS (S-VHS) VCR to the TV.

► **Important:** If you connect Super VHS equipment (S-VHS), EXT-1 or EXT-2 will automatically be the input for viewing your VCR.

- ④ **video input terminals**
Use to connect the video output from a standard VCR or another component to the TV.
- ⑤ **audio input terminals**
Use to connect the audio output from a VCR or other equipment.
- ⑥ **video tuner output terminal**
Use to connect the video to a Home Theater receiver.
- ⑦ **audio tuner output terminals**
Use to transmit the audio to a Home Theater receiver.
- ⑧ **S-video monitor output terminal**
Use to connect the S-video of the TV to a VCR, Video Copy Processor, etc.
- ⑨ **video monitor output terminal**
Use to connect the video of the TV to a VCR, Video Copy Processor, etc.
- ⑩ **audio monitor output terminals**
Use to connect the audio of the TV to an audio amplifier.
- ⑪ **active A/V Network terminal**
Use to connect Mitsubishi products that have A/V network terminals.

◆ Basic Connections

This section explains the basic connections you will need to make between your TV, antennas, and VCR. You will see there are different connections shown depending upon whether you have a decoder box and the type of antenna you are using. Choose the type of connection for the equipment you have.

This section explains:

- **TV+external speakers,**
- **TV+antenna or cable without a decoder box,**
- **TV+antenna or cable with a decoder box,**
- **TV+separate UHF and VHF antennas,**
- **TV+VCR+antenna or cable without a decoder box,**
- **TV+VCR+antenna or cable with a decoder box,**
- **TV+home theater receiver (A/V receiver),**
- **TV+audio system, and**
- **TV+Mitsubishi products that have A/V Network terminals.**

▷ **Important:** You must connect a VCR to see two active images when using Picture-In-Picture (PIP).

TV+external speakers

equipment you'll need

To complete this hook-up, you'll need:

- 1 set of speaker lead wires.

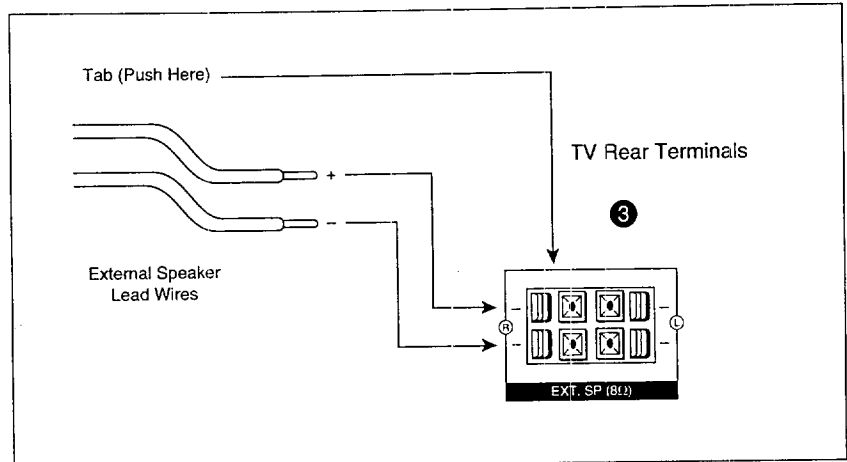
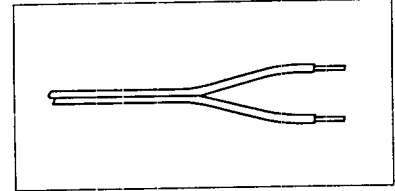

procedure

- 1 Turn the TV off.
- 2 Connect the speaker wires to the external speakers.
- 3 Push down on the tab of the external speaker (EXT SP) terminal on the back panel of the TV. Insert the appropriate speaker lead into the terminal. Be sure that the + and - leads from the speakers are connected to the corresponding +(red) and -(black) external speaker terminals.
- 4 To listen to external speakers, set the speakers to "External" with the on-screen audio functions. (Please see page 68.)

► Warning:

Never connect equipment other than speakers to the external speaker terminals.

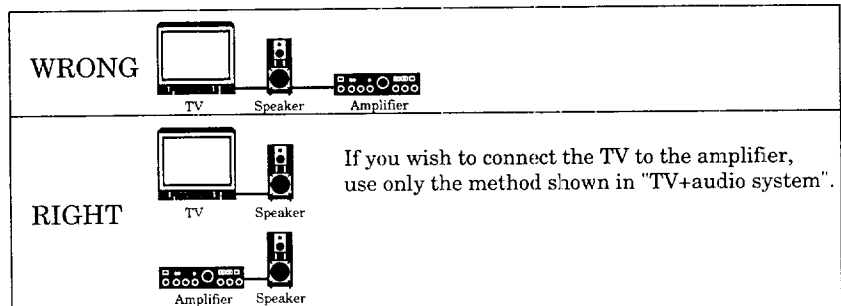

TV+antenna or cable without a decoder box

equipment you will need

If you have a standard 75-ohm coaxial cable, you will not need additional equipment. If your antenna has two leads (called flat twin leads), you'll need:

- (1) 75-300 ohm transformer.

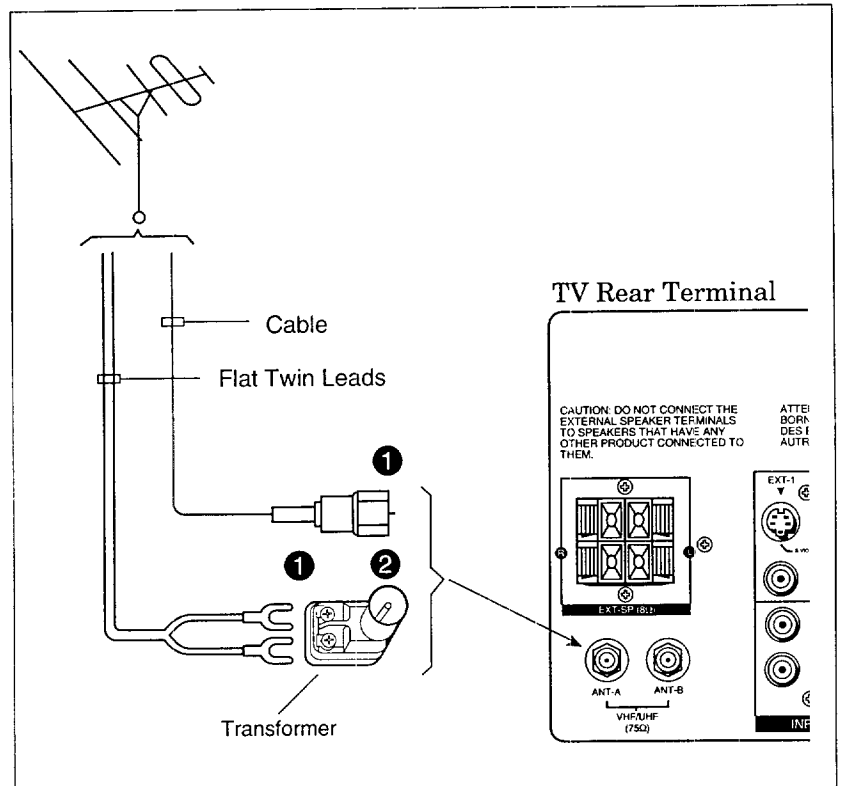
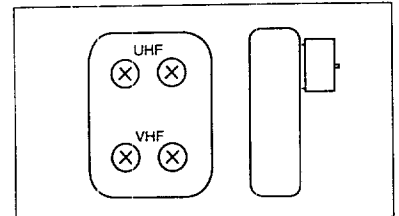

connecting a cable

- 1 Push or screw the end of the cable onto the ANT-A terminal on the television.

connecting an antenna with flat twin leads

- 2 Use a screwdriver to connect the leads to the transformer.
- 3 Push or screw the transformer onto the ANT-A terminal on the television.

TV+antenna or cable with a decoder box

equipment you'll need

Use this hook-up if you need a decoder box to descramble cable signals. This hook-up will allow you to use the remote control to change channels.

To complete the hook-up, you'll need:

- (1) two-way splitter, and

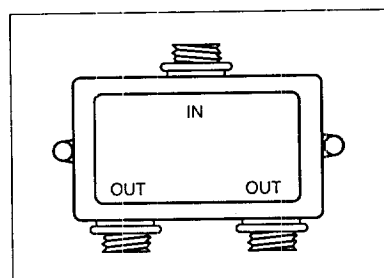

- 3 lengths of 75 ohm coaxial cables.

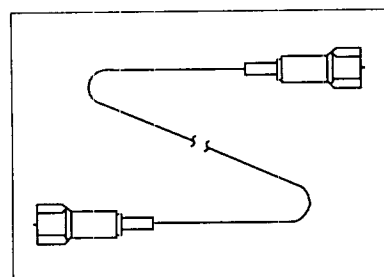

procedure

(Please see illustration on the following page.)

- ➊ Connect the incoming cable to the IN terminal on the two-way splitter.
- ➋ Connect a coaxial cable to one of the OUT terminals on the same splitter; connect the other end of this cable to the ANT-A terminal on the back of the TV.
- ➌ Connect the second coaxial cable to the second OUT terminal on the same splitter; connect the other end of this cable to the IN terminal on the decoder box.
- ➍ Connect the third coaxial cable to the OUT terminal on the back of the decoder box, and the other end of this cable to the ANT-B terminal on the back of the TV.

TV+antenna or cable with a decoder box (cont.)

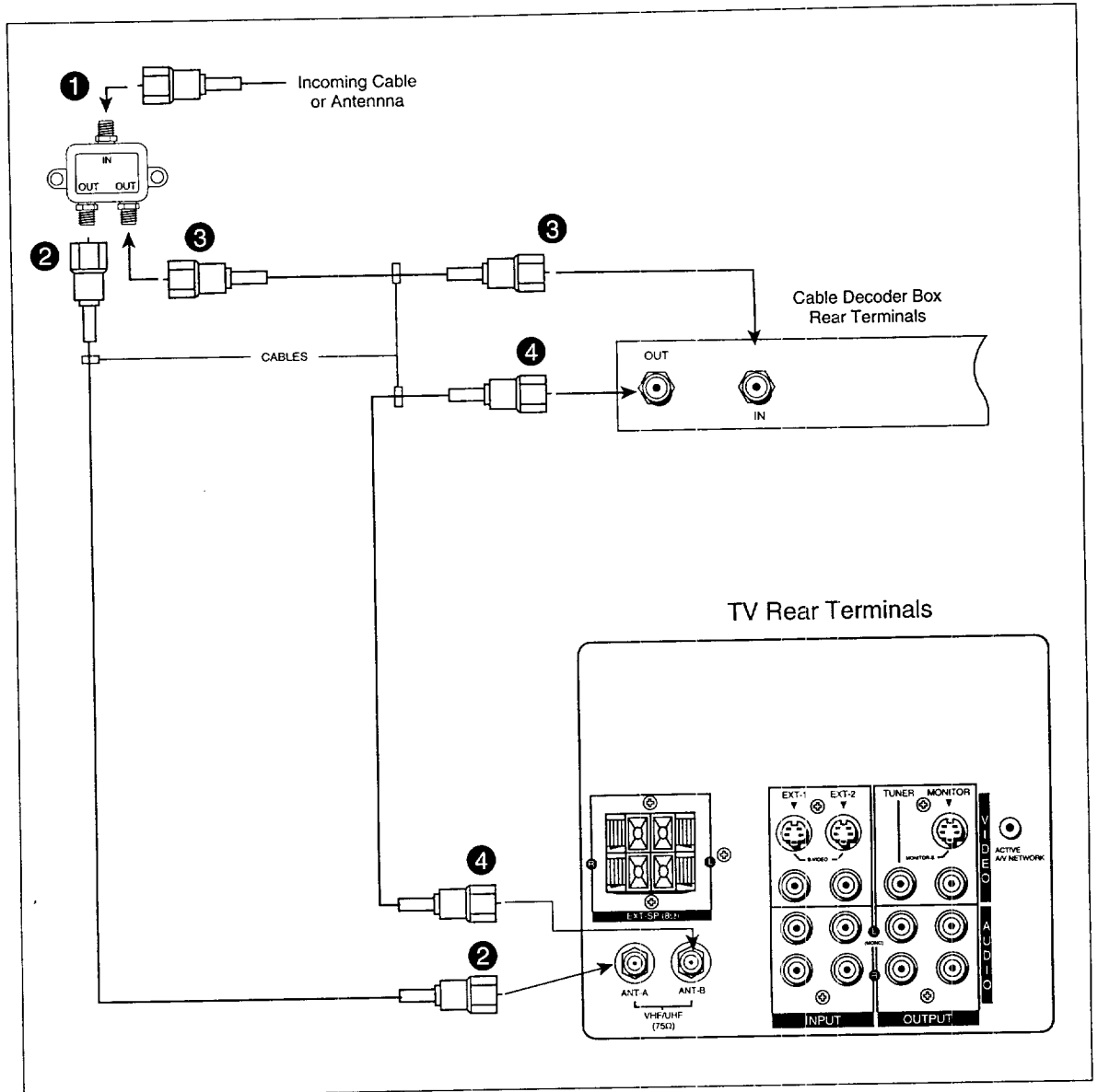

TV+ separate UHF and VHF antennas

equipment you will need

If UHF and VHF signals are brought into your home with two separate antennas, you'll need to combine the antennas into a single wire to connect them to the TV. To do this you will need a UHF/VHF combiner. (There are different combiners for different kinds of leads. Check with your local electronics store for the kind of combiner you need.)

Pictured below is a standard combiner.

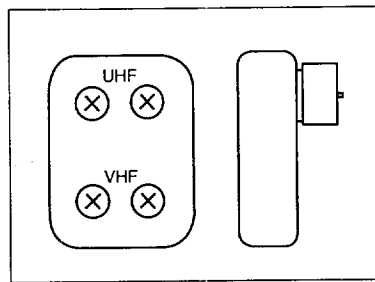

To connect separate UHF and VHF antennas to your television:

- 1 Connect the antenna leads to the UHF/VHF combiner.
- 2 Press the combiner onto the ANT-A terminal on the television.

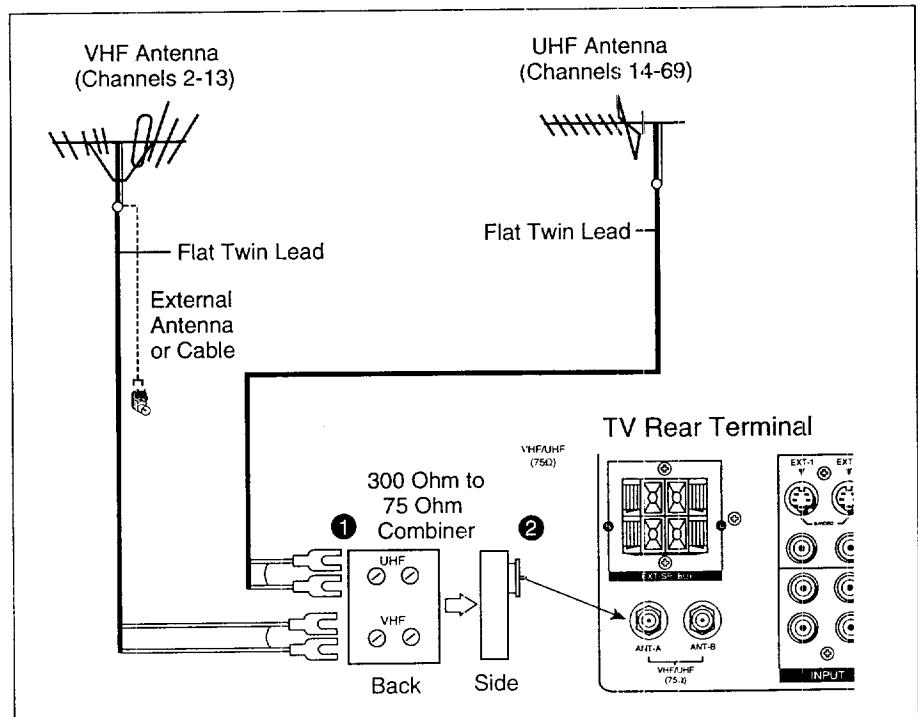

TV+VCR+antenna or cable without a decoder box

equipment you will need

You may want to connect a VCR along with your antennas or cable. To complete this hook-up, you may need the following equipment.

- (1) length of coaxial cable,

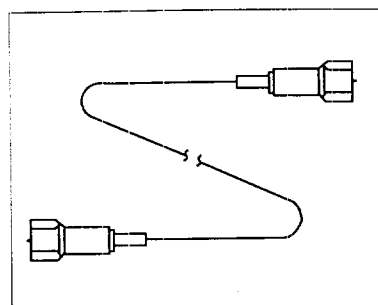

- 1 set of RCA pin-type audio cables,

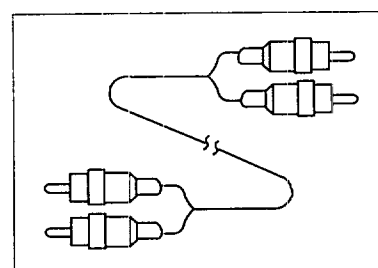

- 1 RCA pin type video cable,
(if connecting a standard VCR),
or

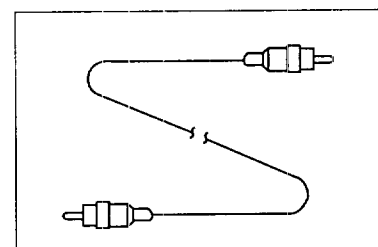

- 1 Super Video cable (S-VHS) for
Super VHS VCRs.

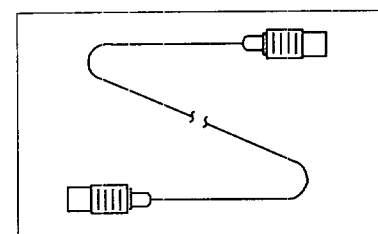

procedure

(Please see illustration on the following page.)

- ❶ Connect the incoming cable or antenna to the ANTENNA IN terminal on the VCR.
- ❷ Connect one end of a coaxial cable to the ANTENNA OUT terminal on the VCR.
- ❸ Connect the other end of the cable to the ANT-A terminal on the TV.
- ❹ Connect an RCA pin-type video cable to the VIDEO OUT terminal on the back of the VCR. Connect the other end of this cable to the VIDEO INPUT terminal on the back of the television.

▷ **Important:** If you are connecting a Super VHS (S-VHS) VCR, use a Super Video cable instead of an RCA pin-type video cable. Connect a Super Video cable to the S-VIDEO OUT terminal on the VCR. Connect the other end of this cable to the S-VIDEO INPUT terminal on the back of the television.

- ❺ Connect a set of RCA pin-type audio cables to the AUDIO OUT terminals on the back of the VCR. Use the red cable to connect the right (R) channel and the white cable to connect the left (L) channel.

- ❻ Connect the other ends of this cable to the AUDIO INPUT terminals on the back of the television.

▷ **Important:** If your VCR is monaural (non-stereo), you will only connect a single RCA pin-type audio cable. Connect the cable to the VCR, then connect the other end to the L (LEFT) audio input on the back of the television.

▷ **Important:** If your VCR has a video channel switch, set it to the "OFF/AV" mode. See your VCR's owner's guide for details.

- ❼ Set the VCR to the playback mode.
- ❽ Select the desired external input source (EXT-1 or EXT-2) by using the INPUT button on the control panel or remote control.

TV+VCR+antenna or cable without a decoder box (cont.)

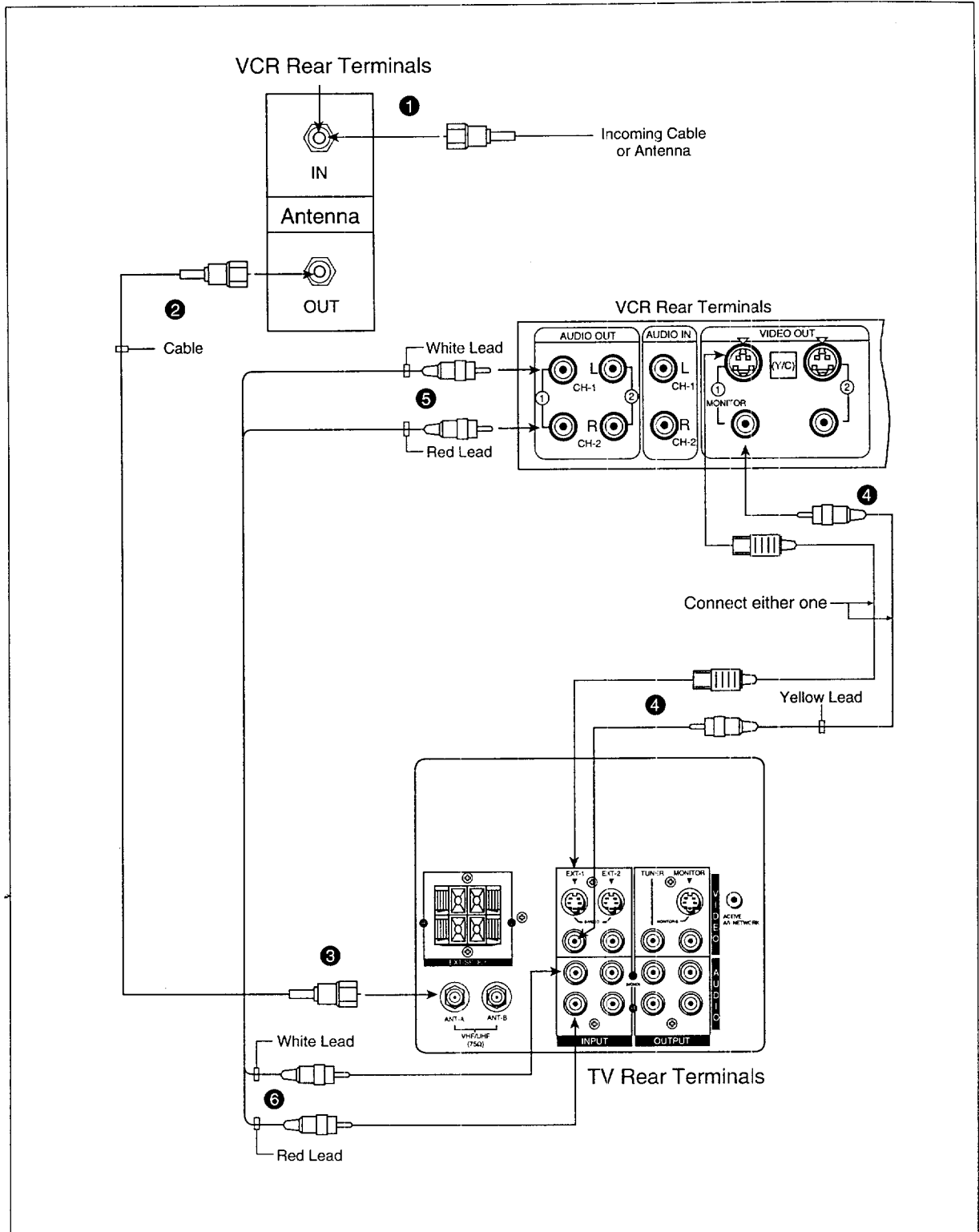

TV+VCR+antenna or cable with a decoder box

equipment you will need

This hook-up will allow you to record scrambled cable channels while viewing another channel.

To complete the hook-up, you'll need:

- 4 lengths of coaxial cable,

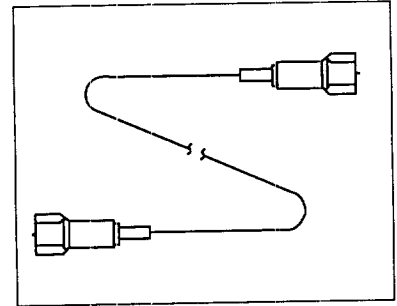

- (1) two-way splitter,

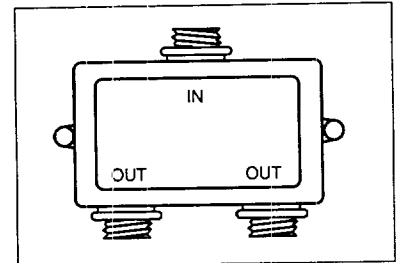

- 1 set of RCA pin-type audio cables,

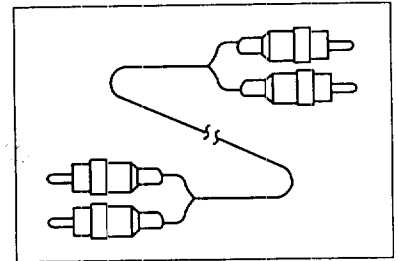

- 1 RCA pin-type video cable, (if connecting a standard VCR), or

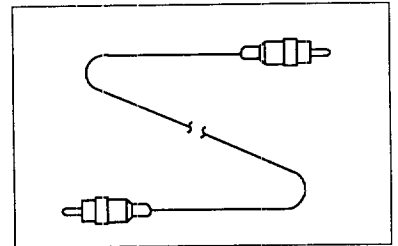

- 1 Super Video cable (S-VHS) for Super VHS VCRs.

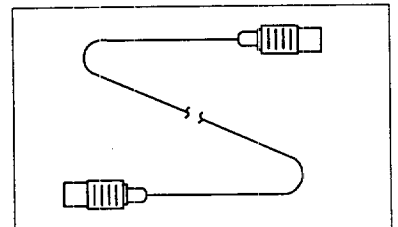

TV+VCR+antenna or cable with a decoder box (cont.)

procedure

(Please see illustration on the following page.)

- ❶ Connect the incoming cable to the IN terminal on the two-way splitter.
- ❷ Connect a coaxial cable to one of the OUT terminals on the splitter; connect the other end of this cable to the ANT-A terminal on the back of the TV.
- ❸ Connect a second coaxial cable to the other OUT terminal on the splitter; connect the other end of this cable to the IN terminal on the decoder box.
- ❹ Connect the third coaxial cable to the OUT terminal on the back of the decoder box; connect the other end of this cable to the ANTENNA-IN terminal on the back of the VCR.
- ❺ Connect the fourth coaxial cable to the ANTENNA-OUT terminal on the back of the VCR. Connect the other end of this cable to the ANT-B terminal on the back of the TV.
- ❻ Connect an RCA pin-type video cable to the VIDEO OUT terminal on the back of the VCR. Connect the other end of this cable to the VIDEO INPUT terminal on the back of the television.

▷ **Important:** If you are connecting a Super VHS (S-VHS) VCR, use a Super Video cable instead of an RCA pin-type video cable. Connect a Super Video cable to the S-VIDEO OUT terminal on the VCR. Connect the other end of this cable to the S-VIDEO INPUT terminal on the back of the television.

- ❼ Connect a set of RCA pin-type audio cables to the AUDIO OUT terminals on the back of the VCR. Use the red cable to connect the right (R) channel and the white cable for connecting the left (L) channel.

- ❽ Connect the other ends of this cable to the AUDIO INPUT terminals on the back of the television.

▷ **Important:** If your VCR is monaural (non-stereo), you will only connect a single RCA pin-type audio cable. Connect the cable to the VCR, then connect the other end to the L (LEFT) audio input on the back of the television.

▷ **Important:** If your VCR has a video channel switch, set it to the "OFF/AV" mode. See your VCR's owner's guide for details.

- ❾ Set the VCR to the playback mode.
- ❿ Select the desired external input source (EXT-1 or EXT-2) by using the INPUT button on the control panel or remote control.

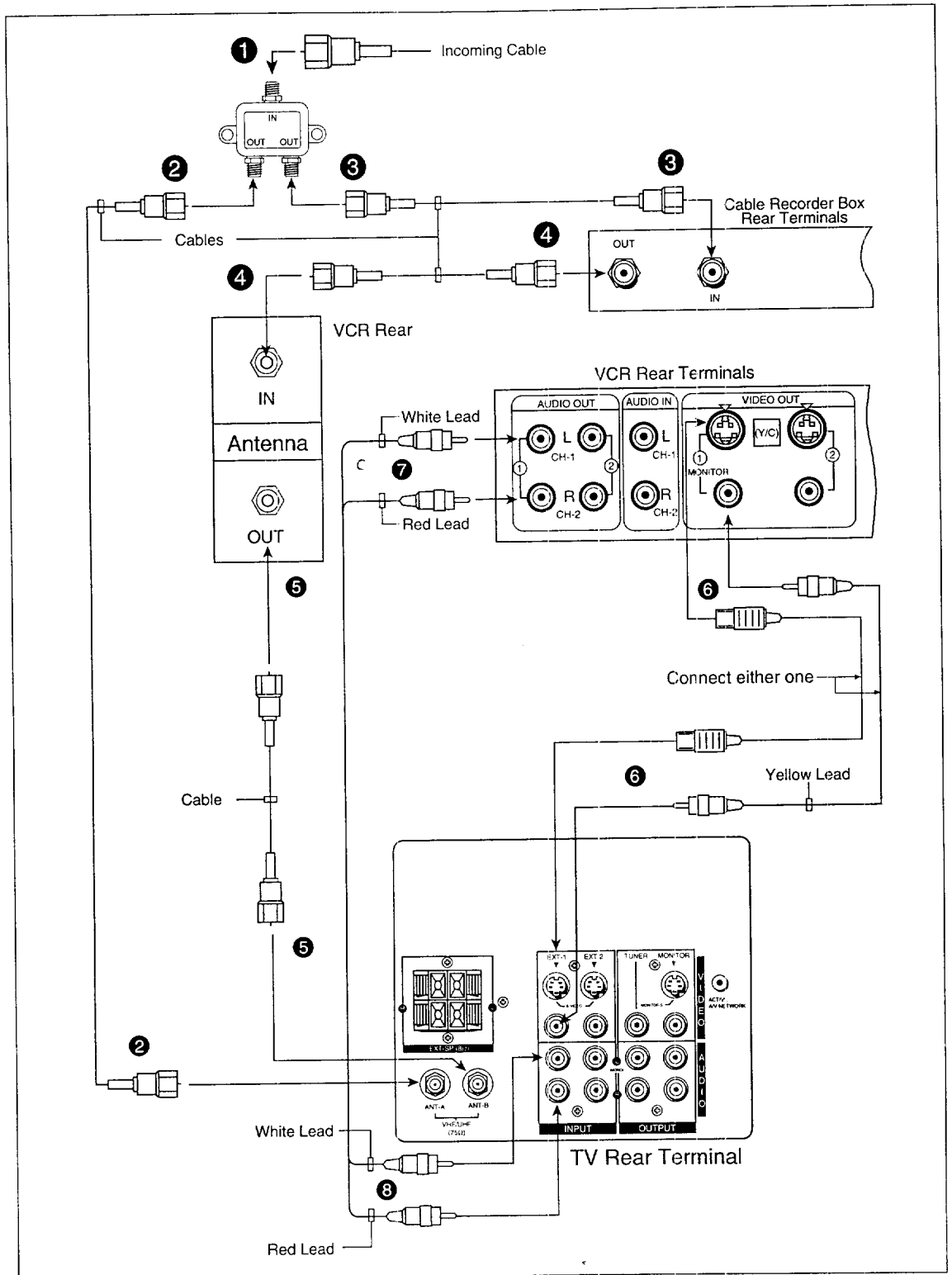

Basic Connections

TV+home theater receiver (A/V receiver)

equipment you will need

To hook-up a home theater receiver, you will need:

- 1 set of RCA pin-type audio cables,

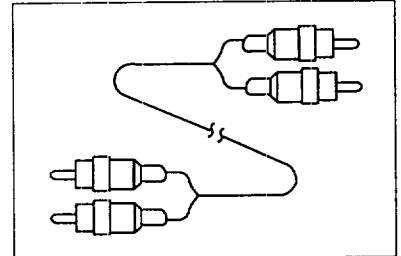

- 2 RCA pin-type video cables (if connecting a standard VCR), or

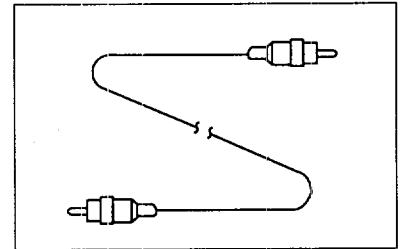

- 1 Super Video cable (S-VHS) and 1 RCA pin-type video cable for a Super VHS home theater receiver.

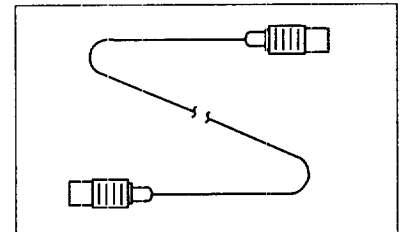

Procedure

- ➊ Connect one end of an RCA pin-type video cable to the TV VIDEO INPUT terminal of the home theater receiver. Connect the other end of this cable to the VIDEO TUNER OUTPUT terminal on the back of the television.
- ➋ Connect one end of an RCA pin-type video cable to the VIDEO OUTPUT terminal of the home theater receiver. Connect the other end of this cable to the EXT-1 VIDEO INPUT terminal on the back of the television.

▷**Important:** If you are connecting a Super VHS(S-VHS) VCR, connect Super Video cable to the S-VIDEO OUTPUT terminal of the home theater receiver. Connect the other end of this cable to the EXT-1 S-VIDEO INPUT terminal on the back of the television.

- ➌ Connect a set of RCA pin-type audio cables to the TV AUDIO INPUT terminal of the home theater receiver. Use the red cable to connect the right (R) channel and the white cable for connecting the left (L) channel.
- ➍ Connect the other ends of this cable to the left and right AUDIO TUNER OUTPUT terminals on the back of the television.

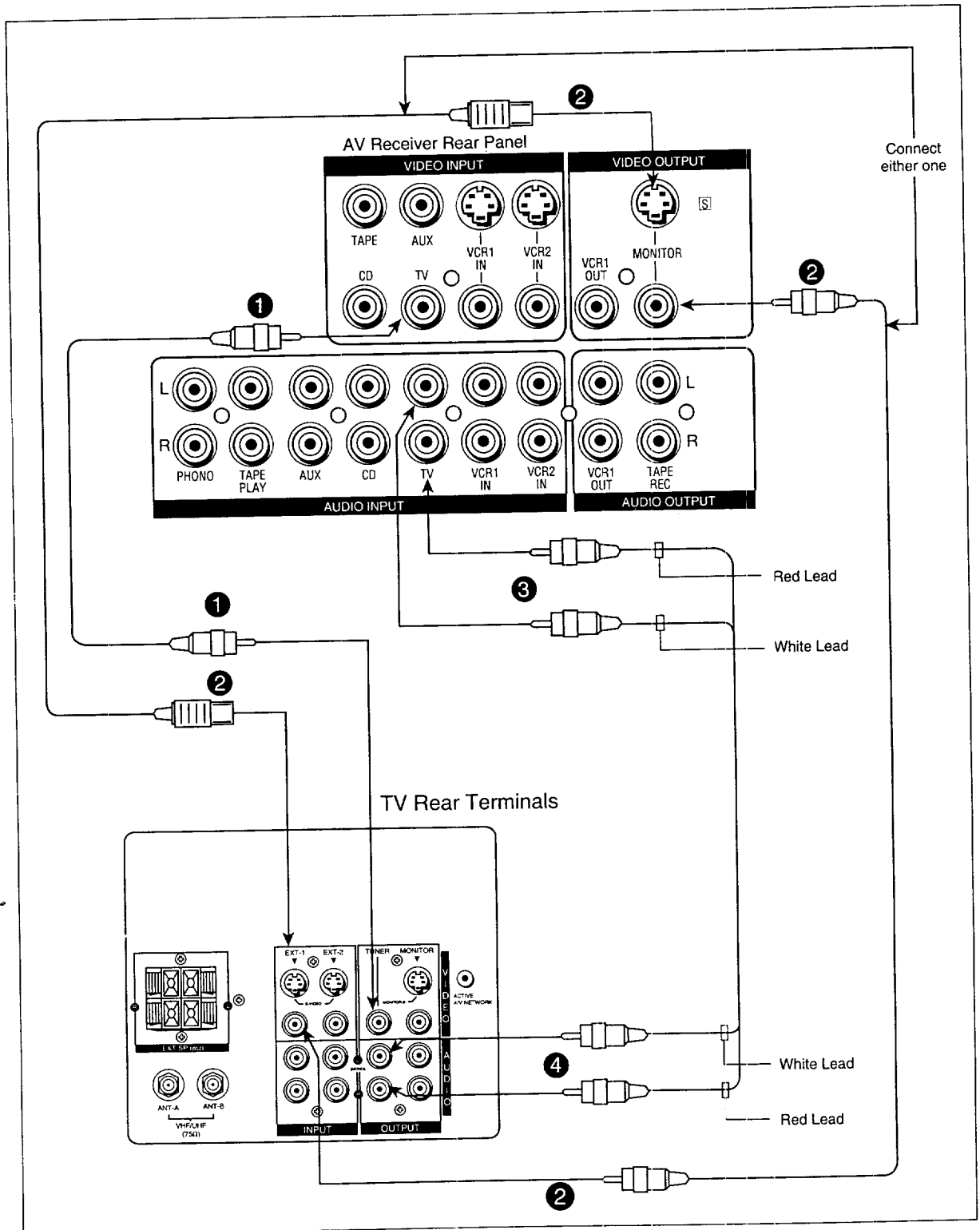

Basic Connections

TV+audio system

equipment you will need

To hook-up an audio system, you will need:

- 1 set of RCA pin-type audio cables.

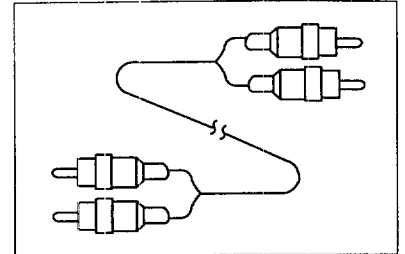

Procedure

- 1 Connect one end of RCA pin-type audio cables to the AUDIO MONITOR OUTPUT terminals on the back of the television. Use the red cable to connect the right (R) channel and the white cable to connect the left (L) channel.
- 2 Connect the other ends of this cable to the AUX IN terminals on the back of the audio system.
- 3 Turn off the television's speakers. To do this, press the AUDIO function button on the control panel or remote control until you see the SPEAKER display. Set the speakers to "External" by pressing the adjust (up/down) or right/left button. See "Adjusting the sound," page 68.
- 4 Set the audio system's input to the AUX position.

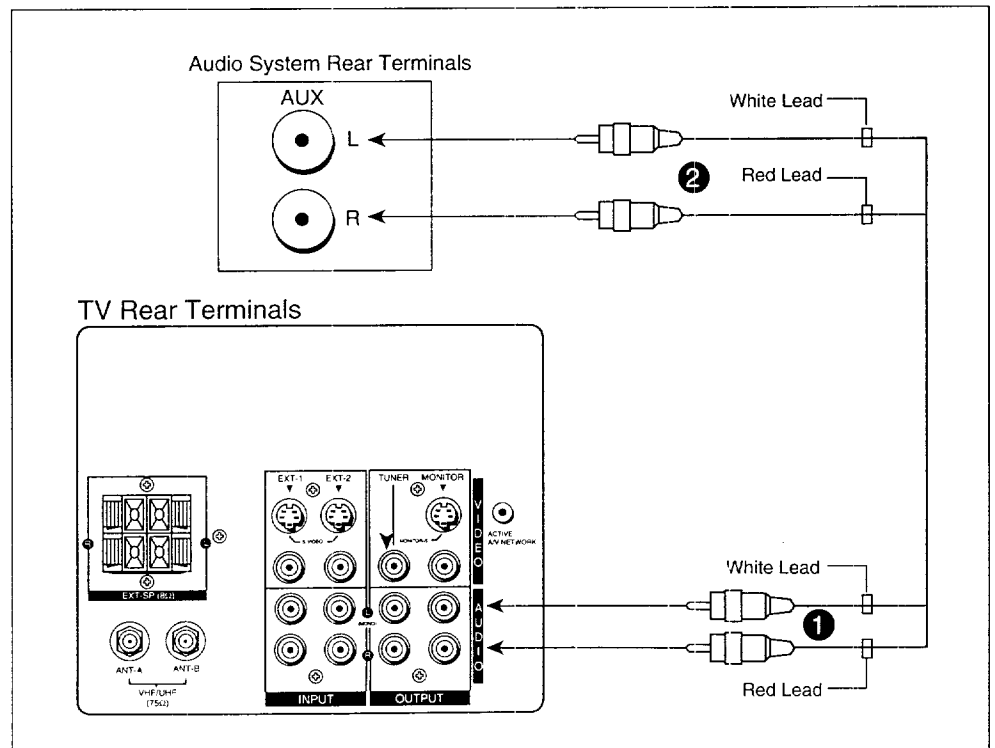

TV+Mitsubishi products that have A/V Network terminals

The A/V Network is a special system that Mitsubishi developed to make it easier to use the remote control. When the supplied cable is connected between two Mitsubishi products with the A/V Network, you can point the remote control at one product and it will "pass" the remote control command to the other.

equipment you will need

- 1 A/V network cable (included with the TV).

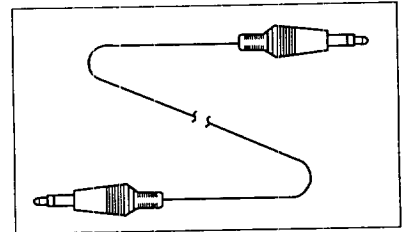

Procedure

- ① Connect one end of an A/V network cable to the ACTIVE A/V NETWORK terminal on the back of the TV.
- ② Connect the other end of this cable to the A/V NETWORK IN terminal on the back of a Mitsubishi component that has A/V network terminals.
- ③ You can now point your component remote (such as a VCR remote) directly at the television. The A/V cable will "pass" the remote commands to the component.

▷ **Important:** The method of connecting the A/V network can change, depending on which components you have and the way you plan to use your equipment. More detailed information is contained in the owner's guide of each particular Mitsubishi component.

TV+Mitsubishi products that have A/V Network terminals (cont.)

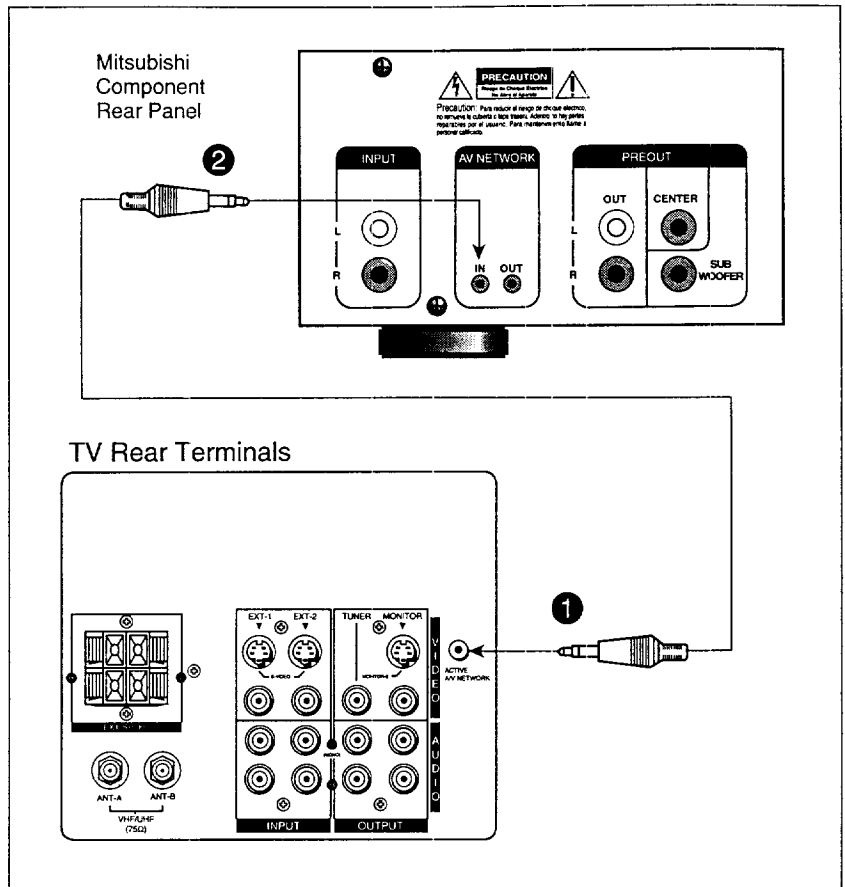



CHAPTER 3

Operating Your TV

Now that your TV is connected to the cable, antennas, or external components, it's time to enjoy your equipment. This chapter will explain how to operate the TV, first focusing on functions that are basic and easy and then explaining some advanced features.

This chapter explains:

- ◆ **Getting Started**
- ◆ **Using the Advanced Features**

◆ Getting Started

This section is designed to get you started enjoying your new TV. If you follow these procedures one by one, you will soon have a picture and can begin discovering everything your television can do.

You'll find information on:

- **Adjusting the color purity,**
- **Using the remote control,**
- **Turning the TV on/off,**
- **Selecting the input source,**
- **Changing channels,**
- **Understanding the on-screen menus,**
- **Setting the clock,**
- **Memorizing channels,**
- **Adding and deleting channels,**
- **Setting the A/V Network,**
- **Renaming the inputs,**
- **Selecting the on-screen language,**
- **Using video mute,**
- **Using the power restore feature,**
- **Using the advanced PIP functions,**
- **Adjusting the sound,**
- **Adjusting the picture, and**
- **Using the closed caption decoder.**

Adjusting the color purity

Your MITSUBISHI color television has a large screen picture tube and color purity may be affected slightly by the earth's magnetic field. For best results, follow the instruction below for color purity adjustment.

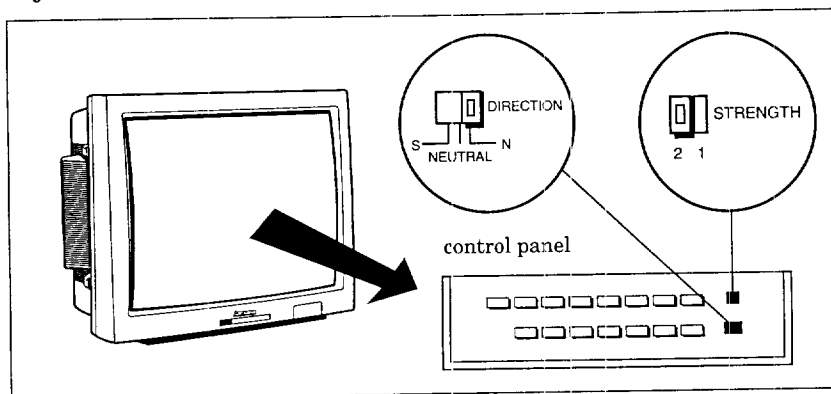

- ❶ Turn off the TV set.
- ❷ Select the desired location and install the set. Determine the compass direction where the set is facing. The direction is determined from the front of the screen facing forward.
- ❸ Select the position for the DIRECTION switch according to the chart below.

TV SET DIRECTION	DIRECTION SWITCH			STRENGTH SWITCH
	S	NEUTRAL	N	
North			X	} 2
North East			X	
North West			X	
South	X			
South East	X			
South West	X			
East		X		
West		X		

- ❹ Turn the TV on, and check the color performance.

- ▷ **Important:**
- If a color impurity is still present, change the STRENGTH switch to position "1". If a color impurity persists after changing the STRENGTH switch position, press the degauss button after a few minutes.
 - The color purity switches must be adjusted each time the set is moved to a new location.
 - If a color impurity still persists after the re-adjustment of color purity switches, contact your MITSUBISHI dealer or MITSUBISHI Authorized Warranty Service Center.

Using the remote control

operating Mitsubishi components

This remote control unit comes programmed to operate Mitsubishi TVs, VCRs and audio components. The select buttons determine which component the remote control will operate.

The following buttons are available when operating this TV set.

- power button
- pause button
- mute control
- super quick view button
- quick view button
- volume control
- input button
- channel control
- enter button
- audio and video controls
- menu button
- cancel button
- display button
- home button
- off-timer button
- number buttons
- PIP controls
- PLAY button
- quick program button

operating VCRs from other manufacturers or cable box

The remote control is pre-set to operate Mitsubishi VCRs, but it can also operate VCRs from other manufacturers as well. If you have a VCR from another manufacturer, or if you have a cable box, it is advisable to set up the remote control.

▷**Important:** Each layer (CABLE, VCR-A or VCR-B) can be set for either a cable box or a VCR.

<setting up the remote control to operate your VCR>

- ① Turn off your VCR.
- ② Choose the layer using the select button on the remote control: VCR-A, VCR-B or CABLE.
- ③ While holding in the POWER button on the remote control, enter the code number listed in the chart on the following page for your brand of VCR. Be sure to enter both digits of the code number. (If more than one code number is listed, try the first one. If that code does not work, try the next one until you find the correct code.)
- ④ Release the POWER button.
- ⑤ Press the POWER button again. Your VCR should turn on. If the VCR turns on, your remote control is now set to operate your VCR.

If your VCR does not turn on, repeat the instructions, trying each code number listed for your brand of VCR.

If your VCR is this brand...	...enter this code	If your VCR is this brand...	...enter this code
Mitsubishi (A)	01	Philips	03, 10, 11
Mitsubishi (B)	02	Quasar	03
Canon	03	RCA	08, 13, 20
Emerson	04, 05	Sanyo	14
Funai	06	Scot	15
GE	03	Sharp	16
Goldstar	07	Sony	17, 18
Hitachi	08	Sylvania	03, 10, 11
JVC	09	Symphonic	06
Magnavox	03, 10, 11	Teknika	04, 06
Multitech	06	Toshiba	15
NEC	12	Totevision	07
Panasonic	03	Zenith	19
Philco	03, 10		

<setting up the remote control to operate your cable box>

- ① Turn off your cable box.
- ② Choose the layer using the select button on the remote control: CABLE, VCR-A or VCR-B
- ③ While holding in the POWER button on the remote control, enter the code number listed in the chart on the next page for your brand of cable box. (If more than one code number is listed, try the first one. If that code does not work, try the next one until you find the correct code.)
- ④ Release the POWER button.
- ⑤ Press the POWER button again. Your cable box should turn on. If the cable box turns on, your remote control is now set to operate your cable box.

If your cable box does not turn on, repeat the instructions above, trying each code number listed for your brand of cable box.

Using the remote control (cont.)

If your cable box is this brand...	...enter this code	If your cable box is this brand...	...enter this code
Zenith	51	Tocom	67, 68, 72
Hamlin	52, 53, 69	Panasonic	63, 70
Jerrold	54, 57, 58, 59, 60, 85, 87	Macom	71
G.I.	55, 56	Philips	73, 74, 75, 76, 77, 93, 94, 95, 96, 97, 98, 99
Oak	61, 62, 82	Regency	79
Pioneer	64, 65, 84		
S.A.	66, 86, 88, 89, 91, 92		

- ▷ **Important:** Sometimes manufacturers will change their products, or they may use more than one code. If this is the case, your remote may not be able to operate your VCR or cable box.
- ▷ **Important:** Each layer (CABLE, VCR-A or VCR-B) can be set for either a cable box or a VCR.
- ▷ **Important:** When you replace the batteries in your remote control, the remote will return to its initial setting.

<using your remote control to operate your VCR>

After you have set up your remote control for your particular brand of VCR, you can use the remote to operate your VCR.

- ❶ Choose the layer using the select button on the remote control: VCR-A, VCR-B or CABLE.
- ❷ Point the remote control at the VCR and press the desired buttons.

If you are using a Mitsubishi VCR, you will be able to use all of the buttons on the remote control to operate your VCR except for MUTE, VOLUME and the PIP function buttons.

If you are using another brand of VCR, you can use the POWER, CHANNEL, REC, STOP, PAUSE, REW, PLAY and FF buttons to operate your VCR.

<using your remote control to operate your cable box>

After you have set up your remote control for your particular brand of cable box, you can use the remote to operate your cable box.

- ❶ Choose the layer using the select button on the remote control: VCR-A, VCR-B or CABLE.
- ❷ Point the remote control at the cable box and press the desired buttons.

Only the POWER and CHANNEL buttons can be used when operating your cable box.

Turning the TV on/off

- ▷ **Important:** Before using the remote control to operate the TV, press the TV button.

Use the POWER button on either the control panel or the remote control to turn the TV on and off.

- ▷ **Important:** Even with the power turned off, there is a small current that continues to flow into the TV. This maintains any changes to the setting as well as operates the built-in clock and timing functions. Unplugging the set will erase these settings, requiring that you set them again. Unplug the TV only when it won't be used for a long time.

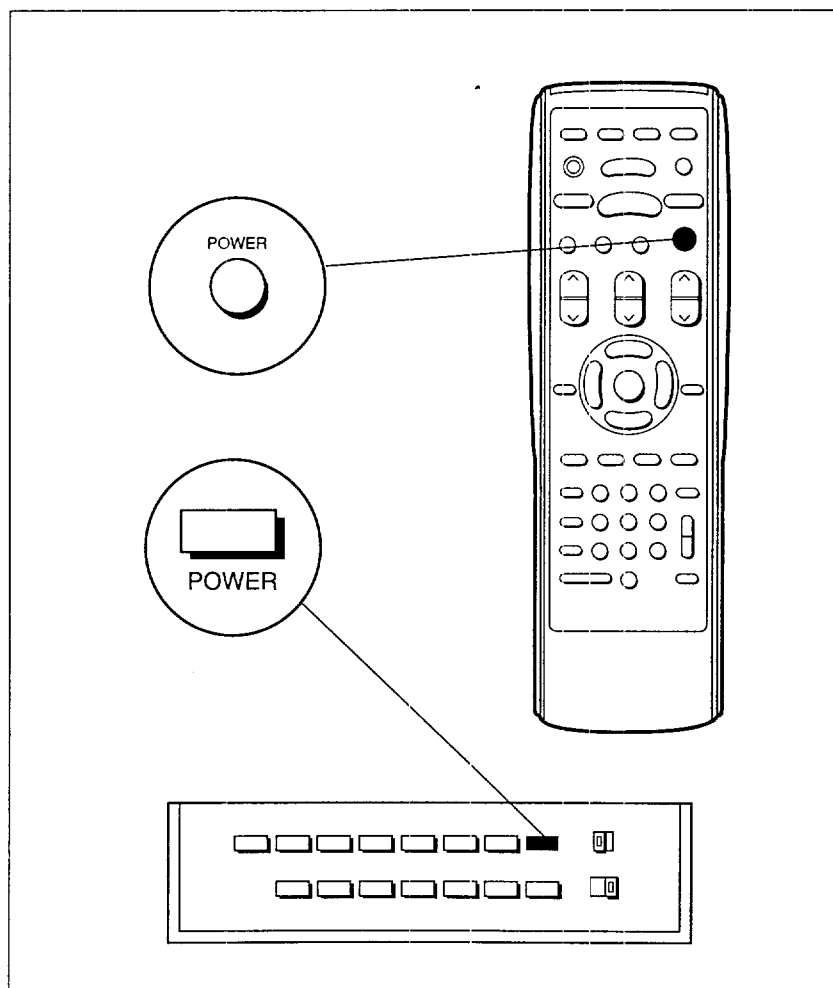

Selecting the input source

Press the input button (INPUT) on the control panel or on the remote control to select the input source you wish to view: Ant-A or Ant-B, Ext-1, Ext-2 or Ext-3.

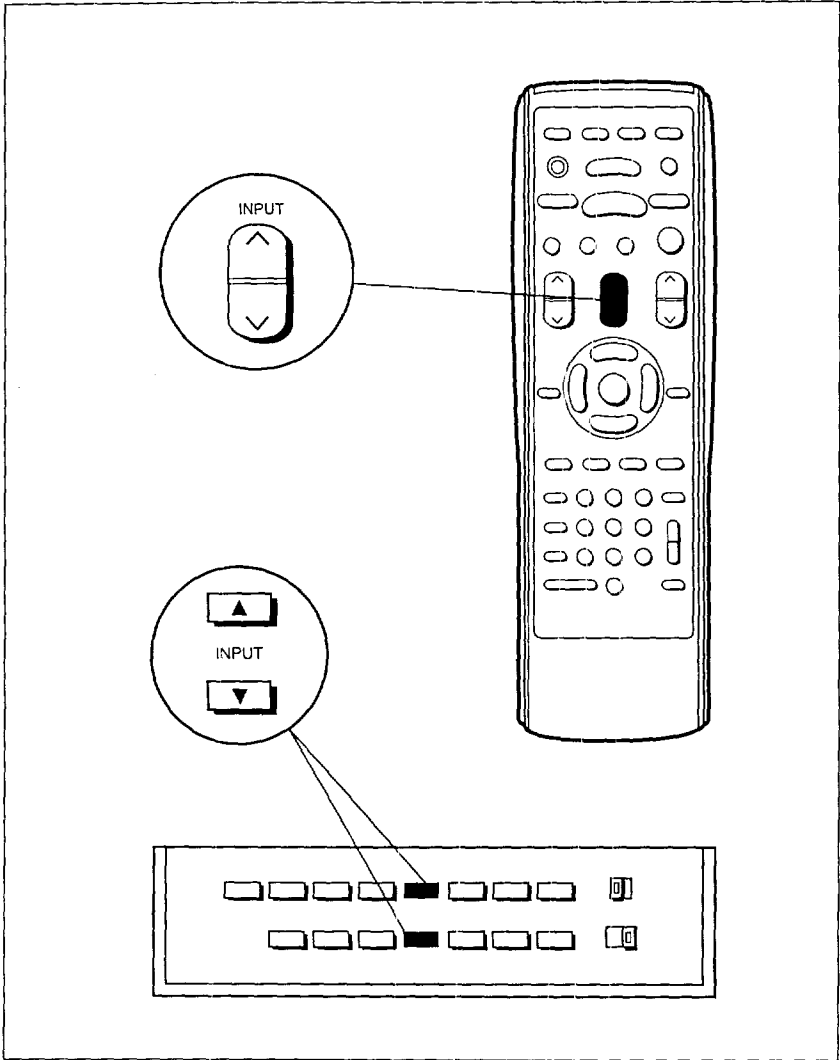

Changing channels

Your TV offers you four ways of changing channels once their numbers have been programmed into channel memory.

- selecting a channel using the automatic channel scan feature.
- directly accessing a channel by pressing the number buttons.
- using the special quick view option to switch to the special memorized channel, and
- using the Super Quick View function to alternate between special channels programmed for quick viewing.

▷ **Important:** To change channels faster, use either of the following procedures:

- Enter three digits for every channel number, using zeros where needed. (For example, enter "004" to view channel 4 and "028" to view channel 28.)
- Press the ENTER button after selecting the number of the channel. (For example, press "4" and "ENTER" to view channel 4.)

▷ **Important:** Cable stations channel numbers 0 and greater than 126 are unassigned. TV stations 0, 1 and 70 through 999 are unassigned. If these channel numbers are pressed, the channel remains unchanged.

changing channels automatically

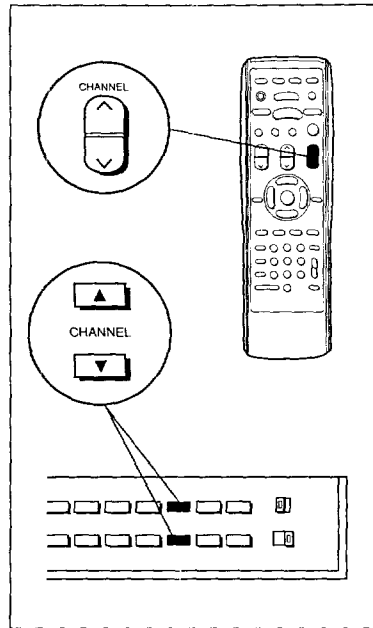

To change channels:

- 1 Press one of the channel controls (CHANNEL) on the control panel or on the remote control. The TV automatically goes to the next broadcasting station.

▷ **Important:** The channel controls (CHANNEL) will work only after channels have been programmed into memory. (See "Memorizing channels," page 60)

changing channels directly

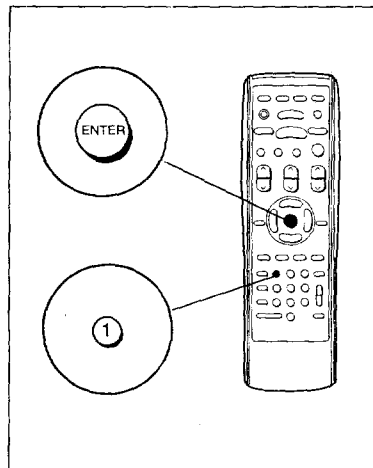

To move directly to a particular channel without going through the programmed channels:

- 1 Use the remote control to select the number of the channel you want to view.
- 2 Press the ENTER button.

Changing channels (cont.)

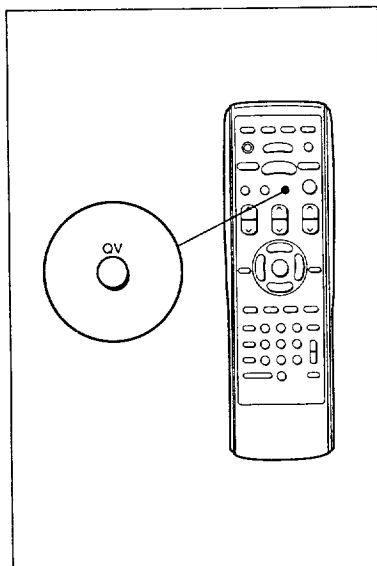

using the quick view option

To switch to the memorized channel as the quick view channel:

- 1 Select the channel you wish to memorize as the quick view channel.
- 2 Press the QV button for about 3 seconds. On releasing this button, the channel number will appear on the screen.
- 3 Press the quick view (QV) button to view the QV channel.

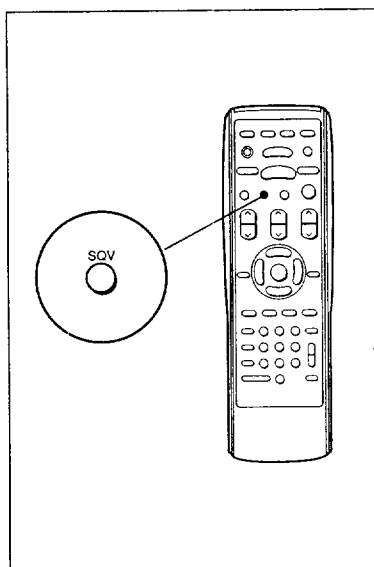

using the super quick view option

To view selected channels programmed into super quick view memory:

- 1 Enter the desired channel into Super Quick View memory. (See "Using the Super Quick View Tuning," page 77.)
- 2 Press the SQV button to view the desired channels in sequence.

Understanding the on-screen menus

One of the distinctive features of this TV is an on-screen menu system that provides step-by-step instructions for using some of the TV's special capabilities.

When using any of the on-screen menus, keep the following in mind:

- The on-screen menus will clear if no item is selected within 5 minutes.
- Unavailable menu items are indicated in light blue.
- Some on-screen menu items must be set before other items are available. For example, "Set the timer" will only be available if "Set the clock" has been set.
- You can exit the on-screen menus any time by pressing the MENU button repeatedly. You will then return to regular TV viewing.
- You can also exit the on-screen menus by pressing the HOME button on the remote control.

Setting the clock

Your TV contains an internal clock to indicate the current time. If there is a broadcaster in your area that is sending the current time along with its regular broadcast signal, then your TV can automatically set its clock with this signal. Otherwise, you can set the clock yourself.

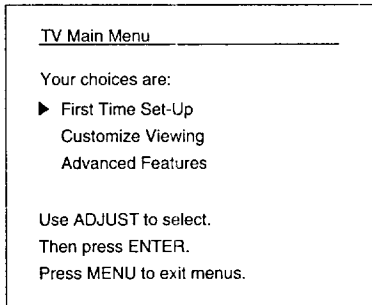

- 1 Press the MENU button on the remote control. The TV Main Menu will appear on the screen.
- 2 Select "First Time Set-Up" using the ADJUST button; then press the ENTER button.

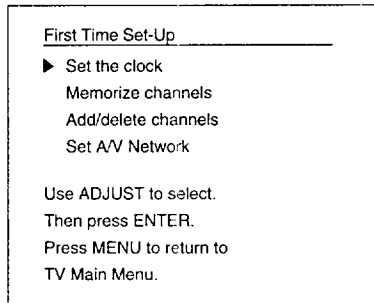

- 3 You will see the "First Time Set-Up" screen. Select "Set the clock" using the ADJUST button; then press the ENTER button.
- 4 If you want your TV to set its clock automatically, use the ADJUST button to set "Auto clock" to "On"; if you want to set the clock yourself, set "Auto clock" to "Off."

<automatic setting>

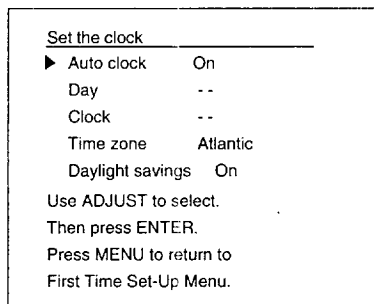

- Set "Auto clock" to "On" using the ADJUST button and press the ENTER button.

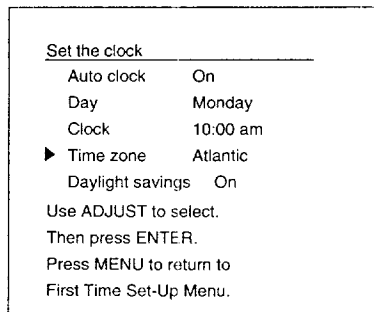

- Select the "Time zone" you are in using the ADJUST button; then press the ENTER button. The available time zones are: Atlantic, Eastern, Central, Mountain, Pacific, Alaska and Hawaii.

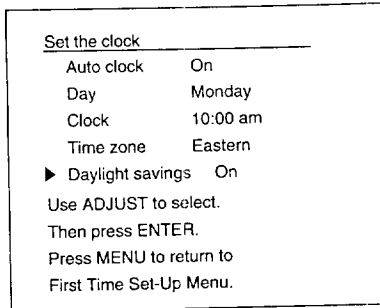

- If you follow daylight savings time, set the "Daylight savings" to "On" using the ADJUST button. If you do not, set it to "Off." Then press the ENTER button.

- The automatic setting is completed, and the clock will start automatically.

The screen will return to the "First Time Set-Up" menu.

▷ **Important:** The TV can only set the clock automatically ("Auto clock") when there is a broadcaster in your area that is sending the current time via Extended Data Services (EDS). The clock will start just after the TV receives the time data.

<manual setting>

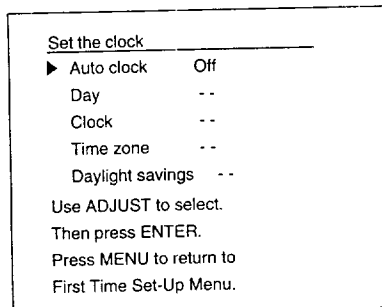

- Set "Auto clock" to "Off" using the ADJUST button and press the ENTER button.

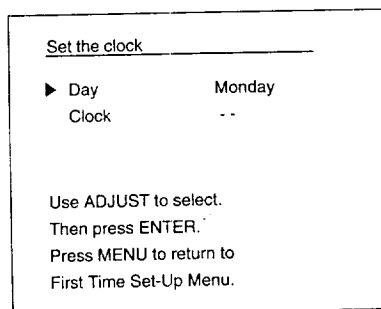

- Select the "Day" using the ADJUST button and press the ENTER button.

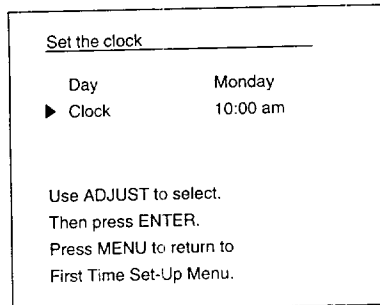

- Set the "Clock" using the ADJUST button.
- After setting Day & Clock, press the ENTER button when the precise minute arrives to start the clock.

The screen will return to the "First Time Set-Up" menu.

Memorizing channels

Your TV automatically memorizes the channels you can receive. Once channels are memorized, you can scan through them using the channel control on the remote control and control panel.

To memorize channels:

First Time Set-Up

Set the clock

- ▶ Memorize channels
- Add/delete channels
- Set A/V Network

Use ADJUST to select.
Then press ENTER.
Press MENU to return to TV Main Menu.

Memorize channels

On which input would you like to memorize?

- ▶ Ant-A
- Ant-B

Use ADJUST to select.
Then press ENTER.
Press MENU to return to First Time Set-Up Menu.

Memorize channels

What is connected to your TV on Ant-A?

- ▶ Cable antenna
- Indoor/outdoor antenna

Use ADJUST to select.
Then press ENTER.
Press MENU to return to First Time Set-Up Menu.

Memorize channels

Now memorizing all the stations you can receive on Ant-A.

Channel 004
 Not in memory

Please stand-by.
To cancel memorization, press CANCEL.

- 1 Press the MENU button on the remote control. The TV Main Menu will appear on the screen.
- 2 Select "First Time Set-Up" using the ADJUST button; then press the ENTER button.
- 3 Select "Memorize channels" using the ADJUST button; then press the ENTER button.

- 4 The instructions for memorizing channels will appear.

Choose either Antenna A (Ant-A) or Antenna B (Ant-B) to memorize channels; then press the ENTER button. Choose whichever input you connected your antenna or cable to. If you connected an antenna to each input, then you should memorize the channels for the one input now, and for the other input later.

- 5 Use the ADJUST button to choose the type of antenna you connected: Cable antenna or Indoor/outdoor antenna. Then press the ENTER button.

- 6 You will see a message that states that channel memorization is in progress. Memorized channels will read "In memory"; channels not in memory say "Not in memory." You may stop channel memorization at any time by pressing the CANCEL button.

▷ **Important:** The channel controls (CHANNEL) will work only after channels have been programmed into memory. After memorizing, use the channel controls (CHANNEL) on the control panel or on the remote control to change channels. Use the number buttons to select individual channels.

Adding and deleting channels

After all available channels have been programmed automatically, channels with weaker signals can be added or deleted by using the following procedure.

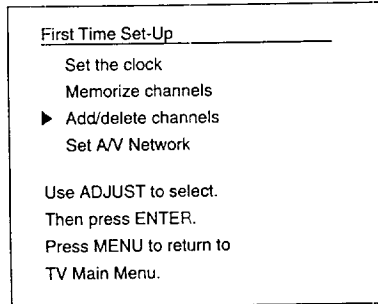

- 1 Press the MENU button on the remote control. The TV Main Menu will appear on the screen.
- 2 Select "First Time Set-Up" using the ADJUST button; then press the ENTER button.
- 3 Select "Add/delete channels" using the ADJUST button; then press the ENTER button.

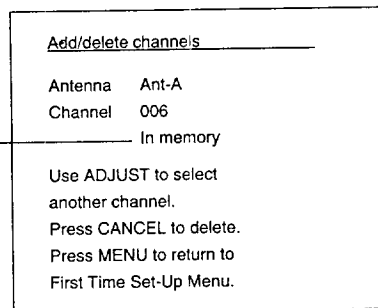

Either "In memory" or "Not in memory" will appear.

- 4 The "Add/delete channels" screen will appear.

Select the channel you would like to add or delete using the ADJUST button; then press the ENTER or CANCEL button. Channels that are in memory have the word "In memory"; channels not in memory say "Not in memory."

- 5 Following the additional on-screen instructions, add a channel into channel memory or delete a channel from channel memory.

▷ **Important:** Only in this menu screen, the CHANNEL ▲ button changes to a channel with a higher number one by one; the CHANNEL ▼ button changes to a channel with a lower number one by one.

You may switch between the antennas (Antenna A and Antenna B) by pressing the input button (INPUT).

Setting the A/V Network

The A/V Network is a special system that Mitsubishi developed to make it easier to use the remote control. When the cable is connected between two Mitsubishi products with the A/V Network, you can point the remote control at one product and it will "pass" the remote control command to the other.

To use the A/V Network:

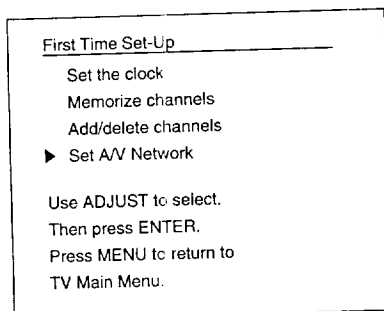

① Press the **MENU** button on the remote control. The Main Menu will appear on the screen.

② Select "First Time Set-Up" using the **ADJUST** button; then press the **ENTER** button.

③ Select "Set A/V Network" using the **ADJUST** button; then press the **ENTER** button.

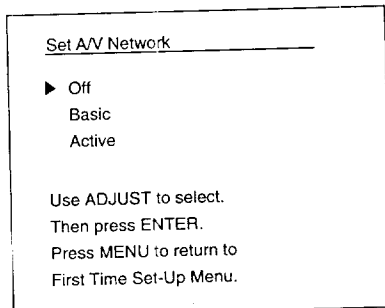

④ Use the **ADJUST** button to select "Active", "Basic", or "Off." Check the rear terminals of your VCR, then use the chart below to determine how you should set your TV.

⑤ Press the **ENTER** or **MENU** button to return to the "First Time Set-Up" menu.

If your VCR has a rear terminal that reads:	...and you have set your VCR to:	then set your TV to:
A/V Network	-	Basic
Active A/V Network	Off	Basic
Active A/V Network	Active	Active
Does not have an A/V Network rear terminal	-	Off

If you are not sure how to set your VCR's A/V Network setting, refer to your VCR's owner's guide.

▷ **Important:** When an A/V Network cable is connected between two products (such as TV and VCR), you can operate the VCR by pointing the VCR's remote control directly at the TV even if you set "A/V Network" to "Off."

▷ **Important:** If you do not use the A/V Network system, set "A/V Network" to "Off." If not, channel selection may not work correctly.

▷ **Important:** If you are using a Mitsubishi VCR with A/V Network or Active A/V Network, you should have connected it to the External 1 (EXT-1) input of your TV.

Renaming the inputs

This feature allows you to rename the external inputs. After renaming, the new name will appear on the screen display.

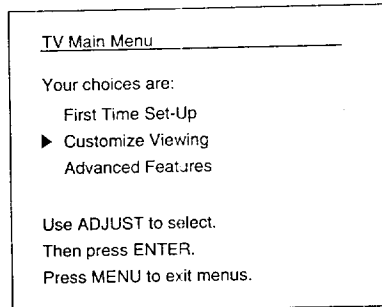

1 Press the MENU button on the remote control. The TV Main Menu will appear on the screen.

2 Select "Customize Viewing" using the ADJUST button; then press the ENTER button.

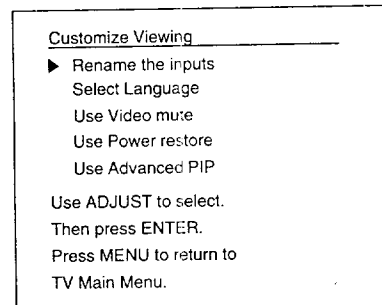

3 You will see the "Customize Viewing" screen. Select "Rename the inputs" using the ADJUST button; then press the ENTER button.

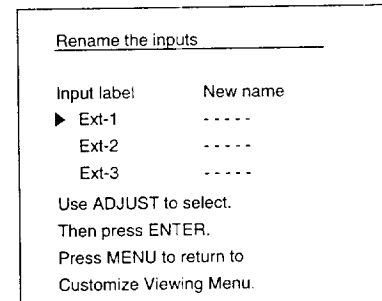

4 Use the ADJUST button to select which input (Ext-1, Ext-2 or Ext-3) you want to rename. Then press the ENTER button.

5 Set the new name using the ADJUST button and the ENTER button.

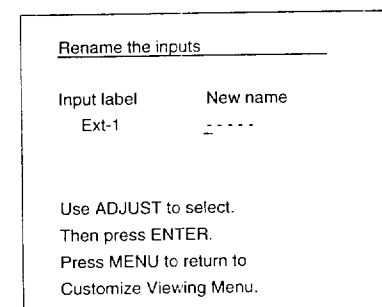

You can rename the inputs using letters (A~Z), numbers (0~9), or symbols (: / . , () ! " # \$ % & ' blank + ; < = > ? blank -).

When you press the CANCEL button while setting the name, the cursor will move one left position. You can clear the entire name by pressing CANCEL when the cursor is at the first position.

6 After naming, press the MENU button; the screen will return to the "Customize Viewing" menu.

Selecting the on-screen language

This TV allows you to see three different language on-screen menus: English, Spanish and French.

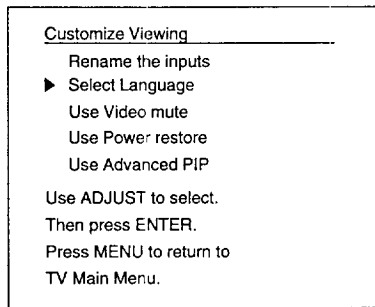

- 1 Press the MENU button on the remote control. The TV Main Menu will appear on the screen.
- 2 Select "Customize Viewing" using the ADJUST button; then press the ENTER button.
- 3 Select "Select Language" using the ADJUST button; then press the ENTER button.

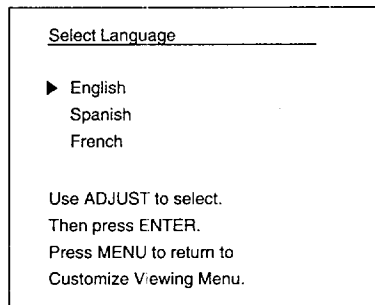

- 4 Select the language for on-screen menu using the ADJUST button.
- 5 Press the ENTER or MENU button to return to the "Customize Viewing" menu.

Using video mute

When using the video mute function, any blank section of video tape is replaced by a blue screen. The sound is also turned off. If there is a case where you might wish to try viewing the playback of noisy tape, you can turn the video mute off.

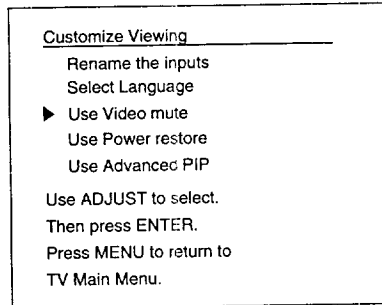

- 1 Press the MENU button on the remote control. The TV Main Menu will appear on the screen.
- 2 Select "Customize Viewing" using the ADJUST button; then press the ENTER button.
- 3 Select "Use Video mute" using the ADJUST button; then press the ENTER button.

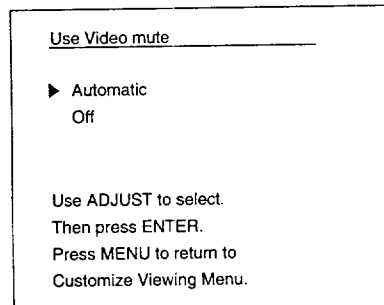

- 4 Select either "Automatic" for video mute on or "Off" for video mute off using the ADJUST button.
- 5 Press the ENTER or MENU button to return to the "Customize Viewing" menu.

Using the power restore feature

When this feature is used, the TV will automatically turn on when electric current is supplied. This feature is useful when, for example, your TV is plugged into an outlet that you control with a wall switch.

To use the power restore feature:

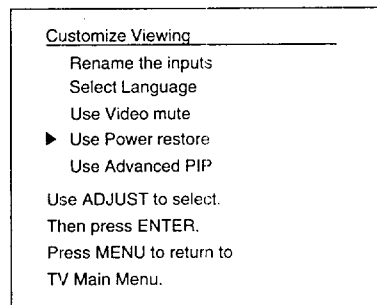

- 1 Press the MENU button on the remote control. The Main Menu will appear on the screen.
- 2 Select "Customize Viewing" using the ADJUST button; then press the ENTER button.
- 3 Select "Use Power restore" using the ADJUST button; then press the ENTER button.

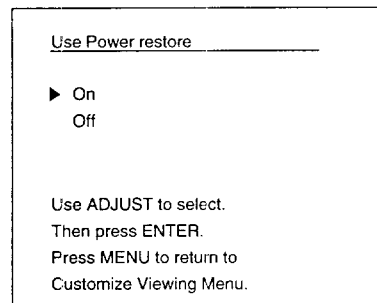

- 4 The "Use Power restore" screen will appear.
Select either "On" or "Off" using the ADJUST button.
- 5 Press the ENTER or MENU button to return to the "Customize Viewing" menu.

- ▷ **Important:** In order for this feature to work, you must leave your TV turned on when you turn off the electric current.
- ▷ **Important:** Even when the power restore feature is used, unplugging the set requires that you reset functions such as the built-in clock and timing functions.

Using the advanced PIP functions

You can use the pause button in the Picture-in-Picture mode to display special PIP features by selecting one of the following settings:

- TV Still,
- Snap-shot, or
- Replay.

In "TV Still," the PIP image switches between still and moving. In "Snap-shot," you can view and move the frozen PIP image. In "Replay," you can view still PIP images in sequence for a "strobe" animation effect. These images will appear in sets of three (from a total of seven stored images) at the speed you select. (See "Using the Picture-in-Picture (PIP) Mode," pages 88-90.)

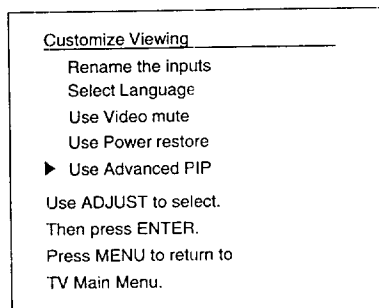

1 Press the MENU button on the remote control. The TV Main Menu will appear on the screen.

2 Select "Customize Viewing" using the ADJUST button; then press the ENTER button.

3 Select "Use Advanced PIP" using the ADJUST button; then press the ENTER button.

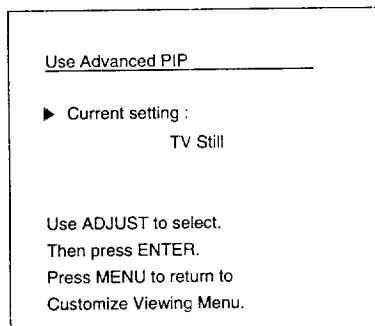

4 Select the current setting: TV Still, Snap-shot or Replay, using the ADJUST button. Then press the ENTER button.

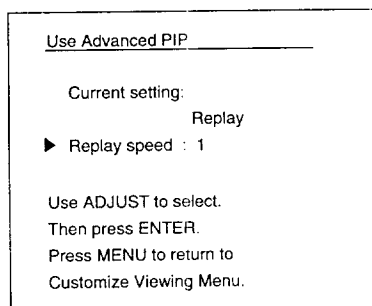

• When you select "Replay," the next option will be "Replay speed." Use the ADJUST button to set the replay speed from 1-9: 1=short interval and 9=long interval. Press ENTER. The main image will replay in sets of three in a "strobe" animation effect at the speed you selected.

5 Press the MENU button to return to the "Customize Viewing" menu.

Adjusting the sound

You can adjust all of your television's sound functions by using a pair of buttons: select a function with the AUDIO button and adjust the function with the ADJUST button or right/left button. You use the ADJUST button to:

- select a position (e.g., stereo),
- increase or decrease the function (e.g., bass), or
- shift from one end of a scale to the other (e.g., balance).

After adjusting the sound, an on-screen display will indicate the function and level you've selected.

what you'll adjust:

"Listen to: Stereo/SAP/Mono" allows you to change the audio reception mode to stereo, separate audio programming (SAP), or monaural (mono), depending on the type of broadcast you are receiving. As you select the reception mode, remember the following:

- The "Stereo" setting allows you to receive both mono and stereo broadcasts.
- The separate audio programming ("SAP") setting offers you the option of listening to either of two separate audio programs. For example, a combination television/radio station may broadcast through the TV.
- The "Mono" setting reduces unwanted background noise when a stereo broadcast is coming in weak. When you use the "Mono" setting, you will hear the broadcast in monaural even when the broadcast signal is in stereo.

▷ **Important:** An on-screen display appears when programs are broadcast in stereo or when separate audio programming (SAP) is available.

"Bass" controls the volume of low frequency sound.

"Treble" controls the volume of high frequency sound.

"Balance" adjusts the level of sound between the left and right speakers.

"Audio expansion: On/Off" creates a stereo effect with non-stereo stations or non-stereo external sources.

"Level sound: On/Off" is used to revise the disparity of the volume between TV mode and External mode, or in cable stations.

"Speaker: Internal/External" controls which speaker (built-in or external) is available. Set to "Internal" for normal operation of the internal speaker system. When connected to external speakers or an external audio system, the speakers can be turned off by setting this function to "External."

"Monitor out: Variable/Fixed" lets you set up the TV for use with a home theater receiver or audio system. Choose "Variable" when you wish to use the television remote control for such functions as volume and mute. Choose "Fixed" if you connected a home theater receiver or audio system. This lets you control functions such as volume and mute through the receiver or audio system.

adjusting the audio functions

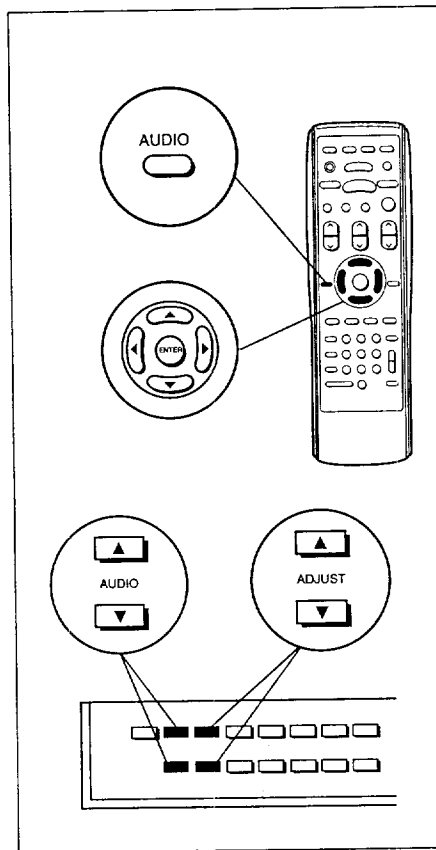

- 1 Use the AUDIO button on the remote control or on the control panel to select one of the functions.
- 2 Use the ADJUST up/down button or right/left button on the remote control or the ADJUST button on the control panel to adjust the function.

Adjusting the picture

You can adjust all of your television's picture functions by using a pair of buttons: select a function with the VIDEO button and adjust the function with the ADJUST button or right/left button. You use the ADJUST button to:

- shift from one end of a scale to the other (e.g., tint),
- increase or decrease the function (e.g., color),
- select a position (e.g., color temperature).

After adjusting the picture, an on-screen display will indicate the function and level you've selected.

what you'll adjust:

"Tint" adjusts the proportion of red to green that determines the delicate tones of color.

"Color" determines the intensity of the color.

"Contrast" controls the level of white-to-black in the picture.

"Brightness" controls the light level of the image on screen.

"Sharpness" adjusts the detail and clarity of the picture.

"Video N(oise) R(eduction): On/Off" is used to reduce background noise that can occur with weak signals. Usually this function is set to "Off".

"Color temp(eration): Low/Middle/High" is used to change the relative warmth of the picture.

"Color bias: Average/Accurate/Skin-tone" is used to improve the color reproduction depending to the input source.

" CC" (closed captioning): 1/2/3/4/Text 1/Text 2/Text 3/Text 4/When muting/Off" is used to display the text information on the TV screen. For details, see "Using the Closed Caption Decoder," page 72.

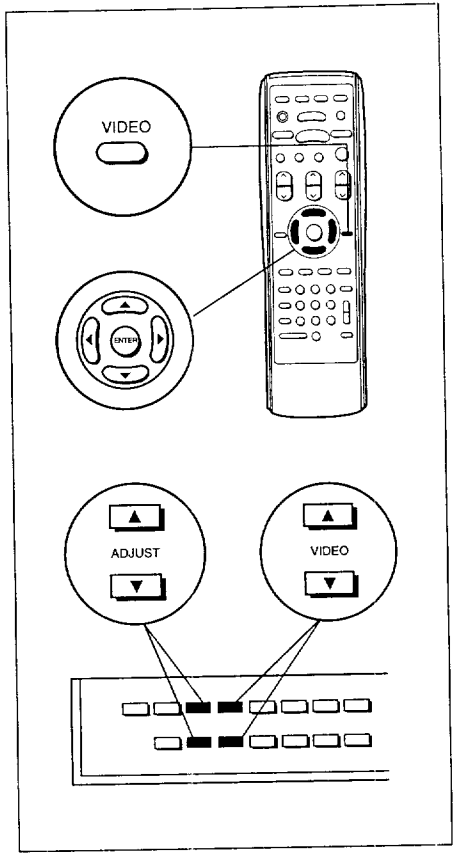

adjusting the video functions

- ❶ Use the VIDEO button on the remote control or on the control panel to select one of the functions.
- ❷ Use the ADJUST up/down button or right/left button on the remote control or ADJUST button on the control panel to adjust the function.

Using the closed caption decoder

Many broadcasters now supply closed captioning information along with their regular broadcasts. Your TV can decode that information and display it on your TV screen.

There are two types of captioning that broadcasters can send: "standard" and "text." Standard captioning usually follows the dialogue of the characters on-screen. Text captioning often contains information such as weather or news and blocks out your view of the program you are watching.

Your TV can decode four different "standard captioning" signals and four different "text captioning" signals on each TV channel.

However, each station may be broadcasting only one or two captioning signals, or none at all.

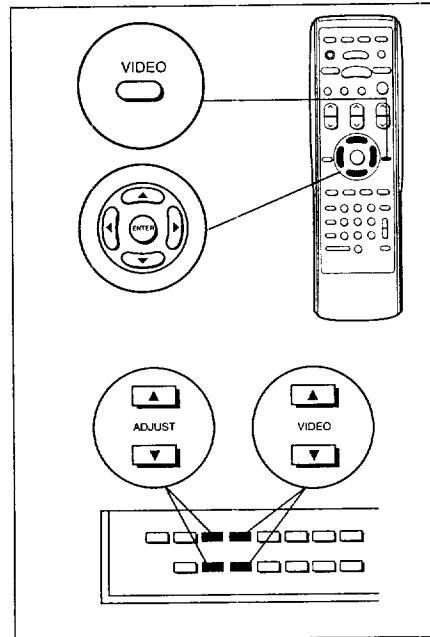

To use the closed caption decoder:

- 1 Press the VIDEO button on the remote control or on the control panel until the closed captioning (CC) display appears on the screen.
- 2 Press the ADJUST button or right/left button on the remote control or ADJUST button on the control panel to select the captioning signal you wish to display.

You can choose to display one of four "standard captioning" signals (indicated by the word CC and a number), to display one of four "text captioning" signals (indicated by the word "Text" and a number), to display captions when muting, or to turn the captions off.

If you select "When muting," the standard captioning signal CC 1 will appear whenever you use the MUTE button.

uses for closed captioning

Closed captioning was initially designed so that those with hearing difficulties can enjoy viewing television more. However, closed captioning can also be used in other ways, such as:

- helping children learn to read,
- learning a foreign language, and
- using the television without disturbing others.

▷ **Important:** If you cannot display any captions on the screen, please keep in mind that not all broadcasters, video tapes, or laserdiscs supply closed caption signals.

◆ Using the Advanced Features

This section explains how to use some of the more advanced functions. You'll learn:

- **Setting the timer,**
- **Using the parental lock, and**
- **Using the Super Quick View tuning.**

Setting the timer

This special feature allows you to program the TV to turn on automatically at a preset time. To set the timer:

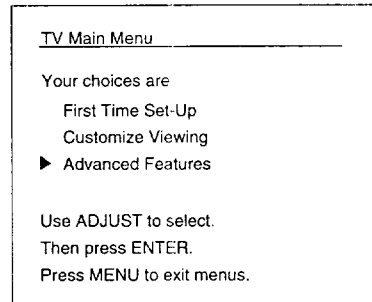

❶ Press the MENU button on the remote control. The Main Menu will appear on the screen.

❷ Select "Advanced Features" using the ADJUST button; then press the ENTER button.

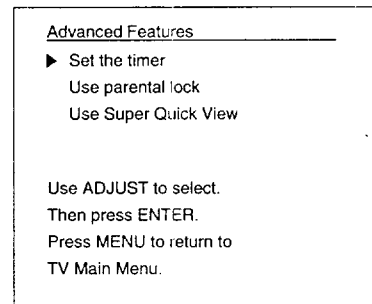

❸ You will see the "Advanced Features" screen. Select "Set the timer" using the ADJUST button; then press the ENTER button.

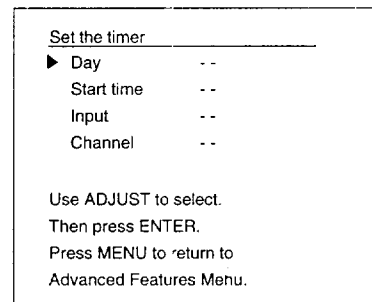

❹ Following the additional on-screen instructions, set Day, Start time, Input and Channel using the ADJUST button and the ENTER button.

After setting the timer, make sure that the program timer indicator lights up. The indicator will not light up when using the menus, or when you have locked the TV.

If you press the CANCEL button while setting the timer, the cursor will move to the previous item. To clear the timer, press the CANCEL button with the cursor at the "Day" position.

▷ **Important:** When the timer turns the TV on, the display will flash as a warning. If you do not press a TV function button for about 5 minutes, the TV will automatically turn off. Pressing a TV function button (ex. display button) causes the TV to remain on and the display to stop flashing.

Using the parental lock

This special feature locks the entire TV or one particular channel to prevent others from watching it.

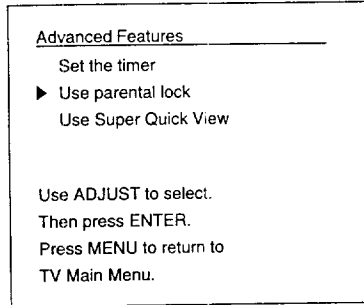

❶ Press the MENU button on the remote control. The Main Menu will appear on the screen.

❷ Select "Advanced Features" using the ADJUST button; then press the ENTER button.

❸ Select "Use parental lock" using the ADJUST button; then press the ENTER button.

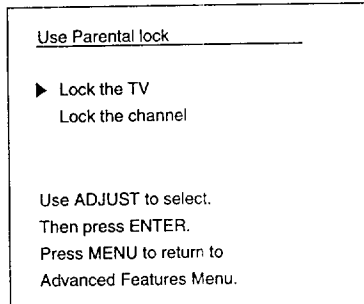

❹ Select "Lock the TV" or "Lock the channel" using the ADJUST button; then press the ENTER button.

- ▷ **Important:**
1. You must first unlock the TV before you can use it with the timer.
 2. When you set the parental lock to "on" and the lock message appears on the screen, the TV will turn off again in about 5 minutes unless you enter the code to unlock it.
 3. The lock message appears when turning the TV on or changing a channel until you set the parental lock to "off".

locking the TV

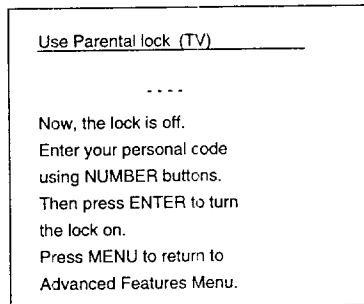

- The message for locking the TV will appear.
- Enter the secret code in four digits using the number buttons (0-9); then press the ENTER button.

You can clear the code pressing the CANCEL button.

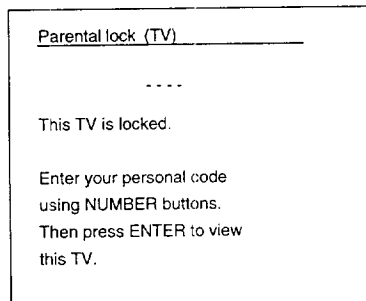

- When you set "Lock the TV" to "on," you will see a message when you next turn the television on asking you to enter your secret code.

Using the parental lock (cont.)

locking the channel

Use Parental lock (Channel)

Now, the lock is off.
Enter your personal code
using NUMBER buttons.
Then press ENTER to turn
the lock on.
Press MENU to return to
Advanced Features Menu.

- The message for locking the channel will appear.
- Enter the secret code in four digits using the number buttons (0-9); then press the ENTER button.

You can clear the code pressing the CANCEL button.

Parental lock (Channel)

This Channel is locked.

Enter your personal code
using NUMBER buttons.
Then press ENTER to view
this channel.

- When you set "Lock the channel" to "on," you will see a message when you next select the channel asking you to enter your secret code.
- Press the channel control (CHANNEL) to view an unlocked channel.

canceling the parental lock

Use Parental lock (TV)

Now, the lock is on.
Enter your personal code
using NUMBER buttons.
Then press ENTER to turn
the lock off.
Press MENU to return to
Advanced Features Menu.

- 1 Press the MENU button on the remote control. The Main Menu will appear on the screen.
- 2 Select "Advanced Features" using the ADJUST button; then press the ENTER button.
- 3 Select "Use parental lock" using the ADJUST button; then press the ENTER button.

Use Parental lock (Channel)

Now, the lock is on.
Enter your personal code
using NUMBER buttons.
Then press ENTER to turn
the lock off.
Press MENU to return to
Advanced Features Menu.

- 4 Using the ADJUST button, select the lock you want to cancel; then press the ENTER button.
- 5 Enter the four digits of your secret code using the number buttons (0-9); then press the ENTER button.
- 6 Press the MENU button to return to the "Advanced Features" menu.

▷ **Important:** If you forget the Parental Lock code, please see page 100.

Using the Super Quick View tuning

Super-Quick-View allows you to cycle through a list of up to ten numbers by using the SQV button. You can use the menu system to add channels to and remove channels from the list.

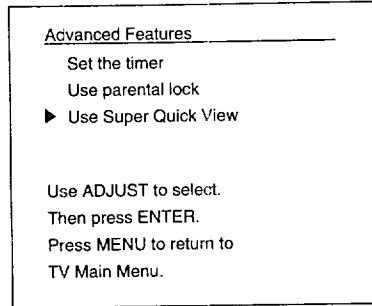

① Press the MENU button on the remote control. The Main Menu will appear on the screen.

② Select "Advanced Features" using the ADJUST button; then press the ENTER button.

③ Select "Use Super Quick View" using the ADJUST button; then press the ENTER button.

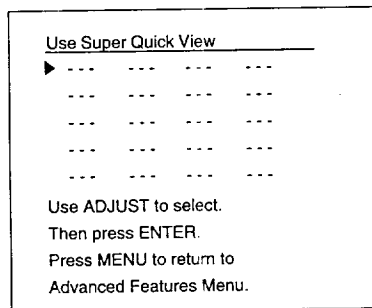

④ Select a position to store a TV channel using the ADJUST button; then press the ENTER button.

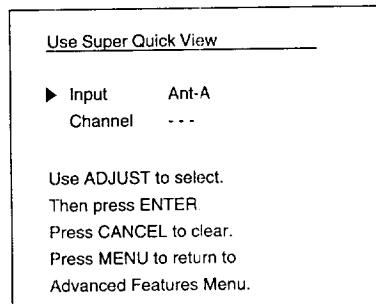

⑤ Use the ADJUST button to select an input. Then press the ENTER button.

⑥ Set a channel number to program into Super Quick View memory using the ADJUST button, the CHANNEL button, or the number buttons; then press the ENTER button.

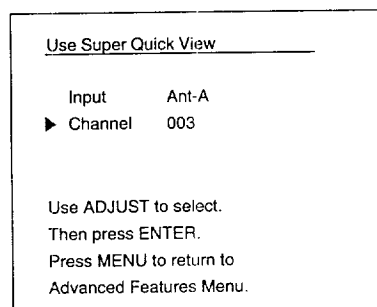

Continue setting the channel numbers until your desired channels are programmed into Super Quick View memory.

⑦ Press the MENU button to return to the "Advanced Features" menu.

▷ **Important:** You can clear each setting (input or channel) by pressing the CANCEL button.



Using the Special Features

In addition to the basic and advanced functions explained in the previous chapter, this TV offers the user several special features not generally available on other brand TVs. This chapter will explain how to use these distinctive features. It contains the following topics:

- ◆ **Understanding the On-Screen Displays**
- ◆ **Using the Off-Timer**
- ◆ **Using the Picture-in-Picture (PIP) Mode**
- ◆ **Using the Active A/V Network Feature**

◆ Understanding the On-Screen Displays

Your TV provides an on-screen summary of the current settings for the TV or cable channels, as well as the information related to Extended Data Services (EDS). EDS allows broadcasters to supply you with the current time, channel information, and program information. To view this information, press the display button (DISPLAY) on the remote control repeatedly. This section describes the displays in the order that they occur.

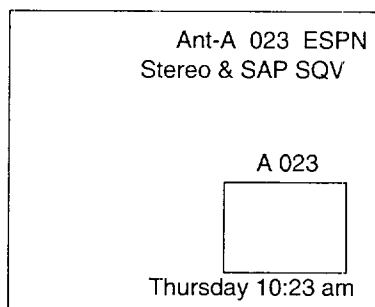

- ❶ This setting indicates the following:
- input source (antenna, channel number),
 - call letters,
 - stereo and/or SAP are available for reception on this channel,
 - this channel is programmed into super quick view memory,
 - PIP input source (when selecting PIP image),
 - current day of the week, and
 - time.

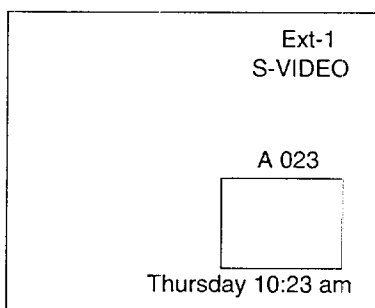

- This setting indicates the following:
- input source (external source or input name),
 - S-VHS cable has been connected,
 - PIP input source (when selecting PIP image),
 - current day of the week, and
 - time.

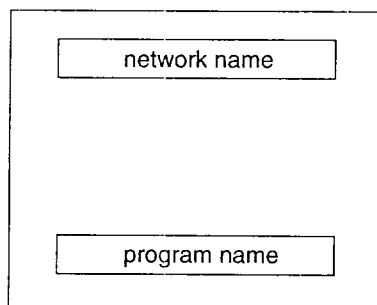

- ❷ This shows you where the network name and program name will appear if the broadcaster is supplying that information via EDS.

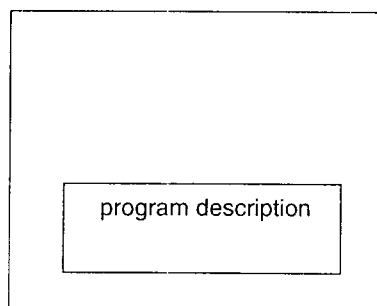

- ❸ This shows you where the program description will appear if the broadcaster is supplying that information via EDS.

▷ **Important:** If the broadcaster is not supplying information via EDS, then the message of no data will appear ("No name available", "No description available"). Additionally, the "call letters" will not appear.

◆ Using the Off-Timer

This special function allows you to set the TV to turn off automatically. You can set the TV to turn off from 10 to 120 minutes (2 hours). In this section you'll learn:

- **Setting the off-timer, and**
- **Changing or canceling the off-timer.**

Setting the off-timer

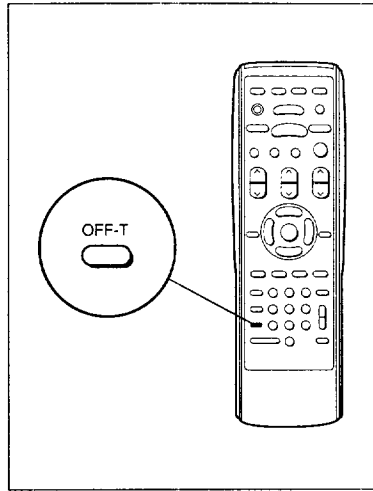

- 1 Press the off-timer button (OFF-T) on the remote control.

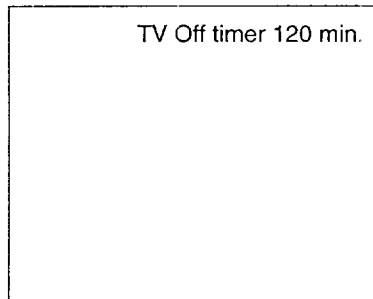

- 2 Select how long you want the TV to stay on by repeatedly pressing the off-timer button (OFF-T). The time will decrease in 10 minute intervals each time you press the button.
- 3 To view the amount of time: press the off-timer button (OFF-T) once. The on-screen display indicates "off-timer" and shows the amount of time remaining.

▷ **Important:** During the last minute before the TV is set to turn off, "Off-timer 1 min." will flash in red to remind you that the off-timer is set.

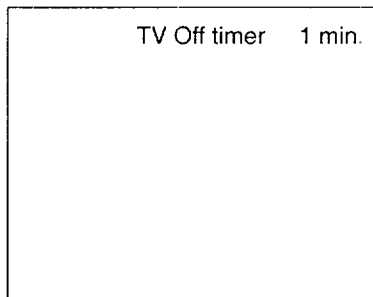

Changing or canceling the off-timer

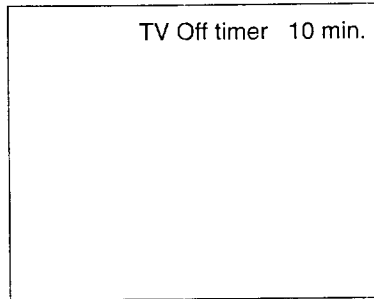

- 1 Press the off-timer button (OFF-T) on the remote control. An On-screen display will indicate the amount of time remaining until the TV will turn off.
- 2 Continue pressing the off-timer button (OFF-T) repeatedly to change the remaining time or cancel the off-timer. The off-timer is canceled when "---" appears instead of the remaining time.

◆ Using the Picture-in-Picture (PIP) Mode

One of the special features of the TV is the picture-in-picture (PIP) mode, which allows you to view two different sources at the same time. In this section you'll learn:

- **Selecting the PIP image,**
- **Selecting the source,**
- **Selecting the channel,**
- **Exchanging the PIP image,**
- **Moving the PIP image,**
- **Freezing the PIP image,**
- **Using the Snap-shot feature, and**
- **Using the Replay feature.**

▷ **Important:** You must have a VCR connected to the TV to see two different live action pictures when using PIP.

Selecting the PIP image

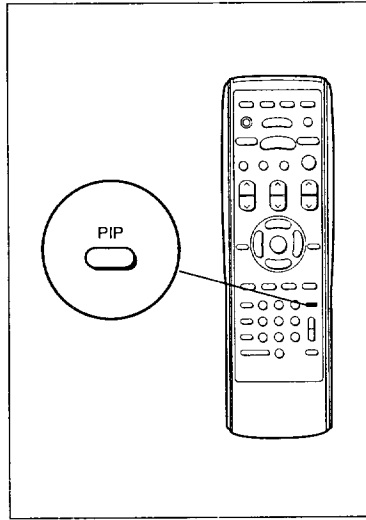

- 1 Select the number of the TV channel you want to view by using the channel control (CHANNEL).
- 2 Press the PIP button. A reduced image will appear in the bottom right corner of the screen.

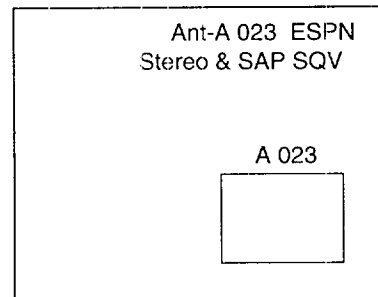

- 3 Press again; the size of the reduced image will change.

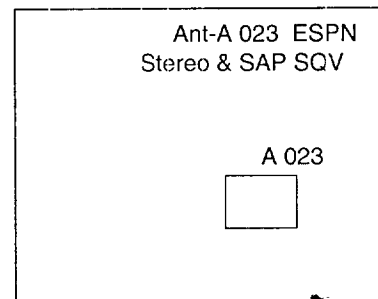

- 4 Press the PIP button once again to cancel the PIP image.

▷ **Important:** When the main image is monochrome (black and white), the PIP image will also appear in monochrome even if the PIP source is in color.

▷ **Important:** After you change the position of the reduced image, the reduced image will appear in your changed position when you select PIP again.

Selecting the source

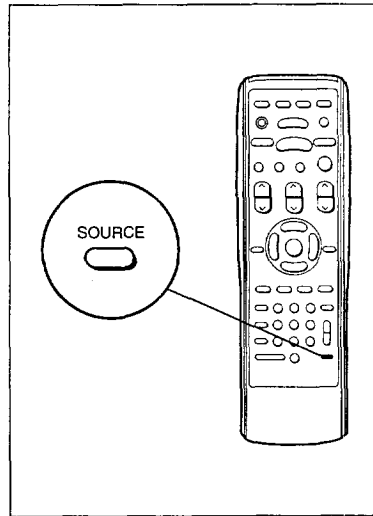

- 1 Turn your VCR on and select a channel on the VCR that is different than the channel you see on your TV screen.
- 2 Press the source button (SOURCE) on the remote control repeatedly to select the source of the PIP image: TV or External.
- 3 The PIP image will change as follows.

→ TV → Ext-1 → Ext-2 → Ext-3

▷ **Important:** To change the background image in PIP mode, press the input button (INPUT) on the control panel or on the remote control.

Selecting the channel

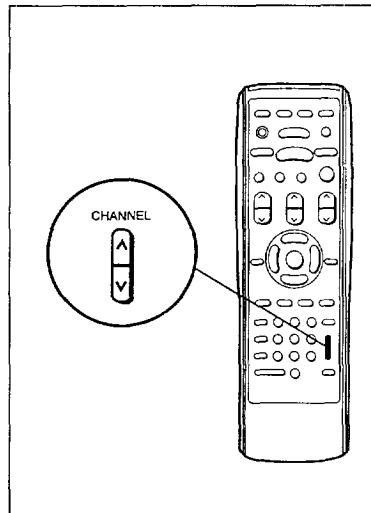

Press the PIP channel button (CHANNEL) on the remote control to change the channel of the PIP image.

▷ **Important:** When the source of the main image and PIP image is the TV, the PIP channel button will change the channels of both the main image and PIP image.

Exchanging the PIP image

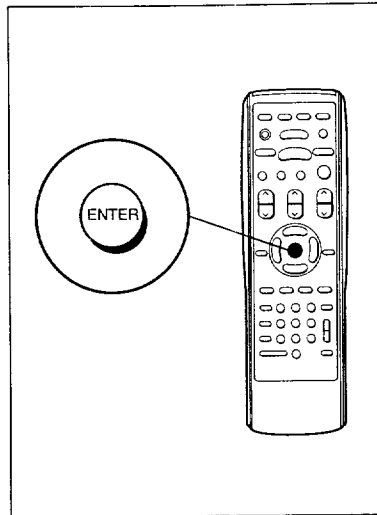

Press the enter (ENTER) button to exchange the positions of the background image and the reduced image.

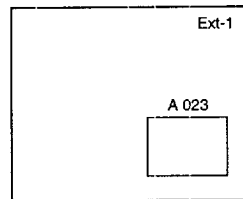
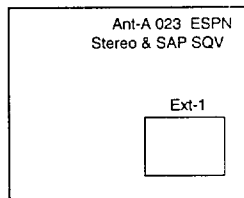

Moving the PIP image

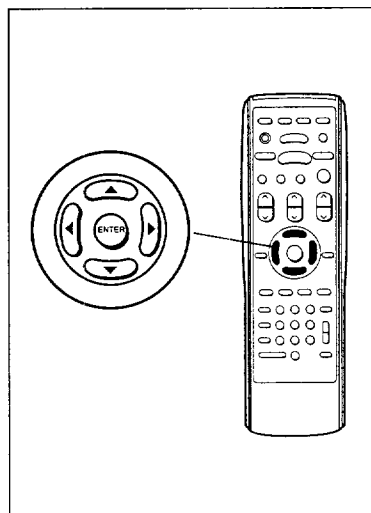

Press the adjust (up/down) button or right/left button to move the reduced image to your desired position.

Freezing the PIP image

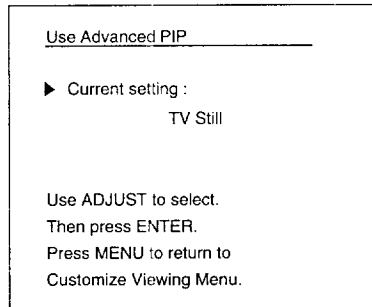

❶ Select "Use Advanced PIP" in "Customize Viewing" menu; then set the current setting to "TV Still." (See "Using the advanced PIP functions," page 67.)

❷ Use the MENU button to return to the normal picture.

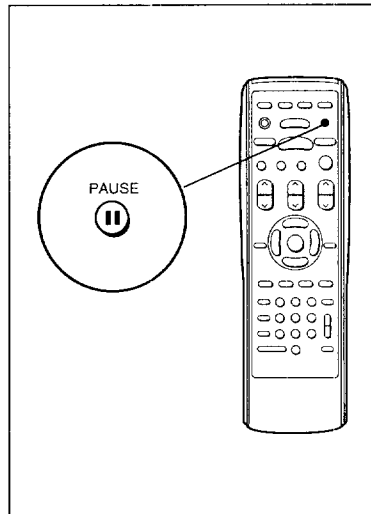

❸ Press the pause button (PAUSE) to freeze the reduced image on the screen.

❹ Press again to cancel the image freezing.

▷ **Important:** When you press the pause button while viewing the normal picture, the PIP image will appear and be frozen.

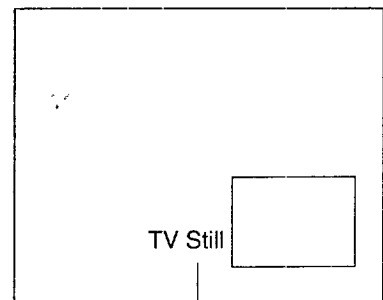

disappears after a few seconds

Using the Snap-shot feature

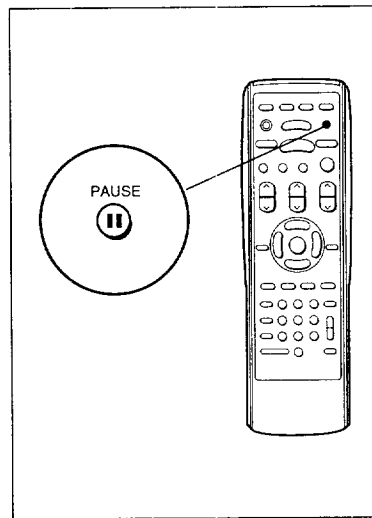
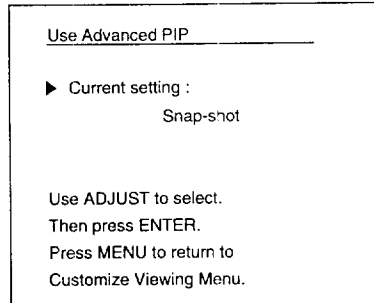

- ❶ Select "Use Advanced PIP" in "Customize Viewing" menu; then set the current setting to "Snap-shot." (See "Using the advanced PIP functions," page 67.)
- ❷ Use the MENU button to return to the normal picture.
- ❸ Press the pause button (PAUSE); the frozen PIP image and the moving PIP image will appear.
- ❹ Press the PAUSE button again; the third PIP image will appear, moving. The previous two PIP images will be frozen.
- ❺ Each time you press the PAUSE button, the PIP images will shift upwards one by one. The top image will disappear and a frozen image appear when you press PAUSE.
- ❻ To cancel the PIP image, press the PIP button twice.

<when PIP is off>

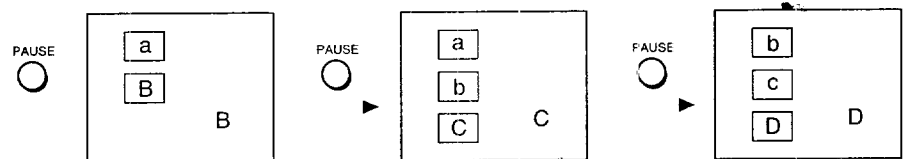

<when PIP is on>

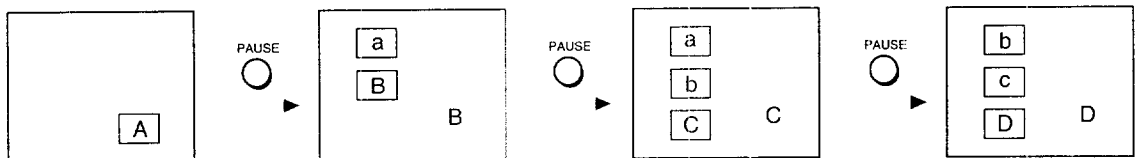

*A, B, C, D : the moving image

*a, b, c, d : the frozen image at the instant the PAUSE button is pressed.

Using the Replay feature

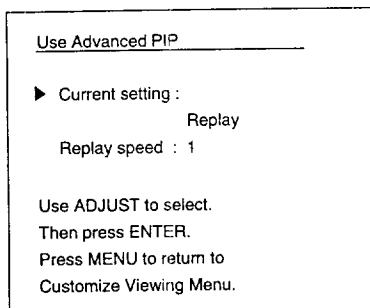

1 Select "Use Advanced PIP" in "Customize Viewing" menu; then set the current setting to "Replay." (See "Using the advanced PIP functions," page 67.)

2 Set the replay speed between 1 (short interval) and 9 (long interval).

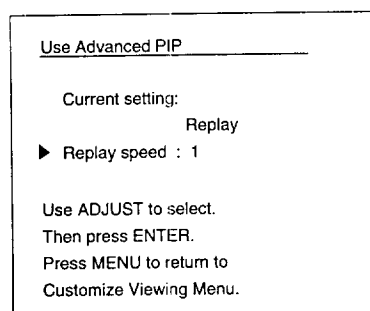

3 Use the MENU button to return to the normal picture.

4 Press the pause button (PAUSE). The main image will be frozen and replayed in sequence for a "strobe" animation effect. These images will appear in sets of three (from a total of seven stored images) at the speed you select.

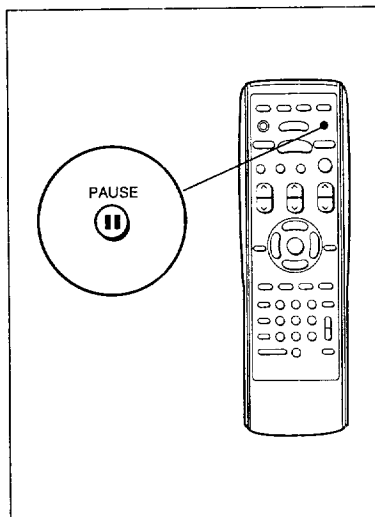

5 Each time you press the PAUSE button, the PIP images will shift upwards one by one.

6 To cancel the PIP image, press the PIP button twice.

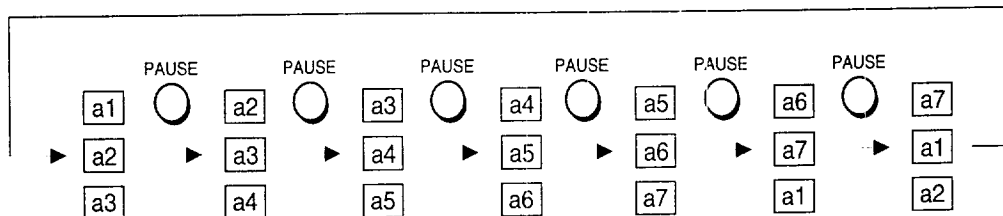
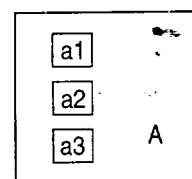

◆ Using the Active A/V Network Feature

This A/V Network is a special feature that makes it easier to use your television and your other A/V components together. When you connect the A/V Network, you can point the remote control at the television, and it will "pass" the remote control command to the other components.

Additionally, you will gain even more benefits if you have a Mitsubishi VCR equipped for the Active A/V Network. The Active A/V Network allows you to perform many of the commonly used features of your system at the press of just one button.

This section will explain the various features of the Active A/V Network.

before you begin

- You must have connected an A/V Network cable from the Active A/V Network terminal of your TV to the A/V Network IN terminal of your VCR. See "TV+Mitsubishi products that have A/V Network terminals", page 43.
- You must have connected your VCR to External 1 (EXT-1) of your TV.
- You must have set your TV's "A/V Network" setting to "Active" or "Basic". See "Setting the A/V Network," page 62.
- Your VCR's remote control switch (if any) should be set to "VCR-A".
- Your VCR's video mute setting should be turned ON.

what the Active A/V Network does

The Active A/V Network makes it easier and faster to use the VCR's Quick Program and Play commands and the TV's PIP commands.

▷ **Important:** When using the Active A/V Network, you should always point your remote control at your television.

Using the active A/V Network (cont.)

using the quick program button (QUICK PROGRAM)

When you press QUICK PROGRAM to begin programming your VCR:

- Active A/V Network will turn on your VCR and bring it to the "Program to Record" screen. (If the VCR's clock has not been set, you will see the "Set the clock" screen. See your VCR's Owner's Guide for information about setting the clock.)
- Active A/V Network will turn on your TV (if it is off), and switch the TV to EXT-1.

You can program your VCR by pointing your remote control at the TV.

When you press QUICK PROGRAM to end programming your VCR:

- Active A/V Network will turn off your VCR (unless a tape is currently playing or recording).
- Active A/V Network will return your TV to the channel it was on before, or turn it off (if it was off originally).

using the PLAY button (AUTO PLAY)

When you press PLAY on the remote:

- Active A/V Network will turn your VCR on and begin playing the tape (if any).
- Active A/V Network will turn your TV on and switch it to EXT-1.

When you turn your TV off:

- Your VCR will turn off, unless it is playing or recording.

using the PIP button (TWO TUNER PIP)

▷ **Important:** You must be watching a broadcast channel on Antenna-A or Antenna-B to use the Active A/V Network PIP function correctly.

When you press the PIP button on the remote to bring up a PIP image:

- Your VCR will automatically turn on.
- You can see the VCR's picture in the small PIP image.

While the PIP image is on the screen:

- The PIP function buttons (SOURCE, CHANNEL, ENTER, right/left, adjust up/down, PAUSE) will all work in the same manner.

- The CHANNEL and number buttons (0-9) will automatically control the small PIP image. You cannot change channels on the main image.

When you press the PIP button on the remote to turn off the PIP image:

- CHANNEL, the number buttons, and all other functions will work normally again.

▷ **Important:** If you turn off the TV while it is set to EXT-1, it will return to the last channel you viewed on Antenna-A or Antenna-B when you turn the TV back on.

▷ **Important:** If you leave the TV turned on, set to EXT-1, but the TV is not receiving a signal on EXT-1, it will automatically turn off after five minutes. (If you use a TV menu during this time, the TV will turn off five minutes after you stop using the menus.)

▷ **Important:** You should not press the PIP button while you are watching a channel that is not receiving any broadcasts. You will not be able to see the small PIP image, and you will not be able to change channels on the main image. You may need to turn off the TV and turn it back on, change to a channel that is receiving a broadcast, and begin again.



CHAPTER 5

Troubleshooting

Even though you're now familiar with the basic and advanced operations of the TV, you may run into trouble from time to time as you become accustomed to the TV. This chapter offers solutions to some of the common problems you may encounter. We suggest that you consult this chart before contacting a Mitsubishi service representative.

Troubleshooting (cont.)

Problems	Possible Solutions	For More Information
<ul style="list-style-type: none">• The remote control doesn't work.	<ul style="list-style-type: none">• Check that the batteries are installed correctly.• Check the select button is set to TV.• Be sure that you are pointing the top of the remote control toward the TV from a distance of no more than 20 feet.	<ul style="list-style-type: none">• See "Getting ready to use the remote control" in Chapter 1 for an explanation of how to install batteries in the remote control.• See "Remote control buttons and functions" in Chapter 1, which explains where the select button is located.• See "Getting ready to use the remote control" in Chapter 1, which contains pointers for using the remote control.
<ul style="list-style-type: none">• The TV takes several seconds to respond to button commands.	<ul style="list-style-type: none">• Use the ENTER button to avoid delays.	<ul style="list-style-type: none">• See "Changing channels" in Chapter 3, which explains the function of the ENTER button.
<ul style="list-style-type: none">• You can't access a channel.	<ul style="list-style-type: none">• Be sure that the channel you want to view is programmed into memory.• Check that the TV is tuned to the correct input source (antenna) for that channel.	<ul style="list-style-type: none">• See "Memorizing channels" in Chapter 3, which explains how to program channels into the TV's memory.• See "Selecting the input source" in Chapter 3, which explains how to change the input source.

Problems	Possible Solutions	For More Information
<ul style="list-style-type: none"> On-screen displays appear each time you adjust a function. 	<ul style="list-style-type: none"> This is part of the normal operation of the TV. 	<ul style="list-style-type: none"> See "Understanding the On-Screen Displays" in Chapter 4 for a full explanation of the on-screen displays.
<ul style="list-style-type: none"> There's no sound even when the volume is turned up. 	<ul style="list-style-type: none"> Check that the MUTE button isn't on. Check the setting of the "Speaker: Internal/External" function. 	<ul style="list-style-type: none"> See "Remote control buttons and functions" in Chapter 1, which explains the location and function of the MUTE button. See "Adjusting the sound" in Chapter 3, which explains how to switch the speakers between "Internal" and "External".
<ul style="list-style-type: none"> You forget the code you used to set the parental lock. 	<ul style="list-style-type: none"> Use the alternate procedure that doesn't require the use of the code. 	<ul style="list-style-type: none"> See the Appendix "Automatic Procedure for the Parental Lock."
<ul style="list-style-type: none"> You can't program the TV to turn on automatically. 	<ul style="list-style-type: none"> The TV may be locked. 	<ul style="list-style-type: none"> See "Using the parental lock" of "Using the Advanced Features" in Chapter 3.
<ul style="list-style-type: none"> The sound doesn't match the image on screen. 	<ul style="list-style-type: none"> The TV's reception mode may be set to "separate audio program (SAP)." 	<ul style="list-style-type: none"> See "Adjusting the sound" in Chapter 3, which explains how to select the appropriate reception mode.
<ul style="list-style-type: none"> The TV picture shows a slight color impurity. 	<ul style="list-style-type: none"> The TV picture may be affected by the magnetic force of the earth. Press the DEGAUSS button. 	

Caution and Care

► **Warning:**

Don't leave stationary images, such as those generated from stock market reports or video games, on-screen for more than 10 minutes. Still patterns can scar the TV causing permanent damage to the picture tube.

- ▷ **Important:** If you plan to place speakers next to the TV, make sure they are magnetically shielded. Ordinary speakers will cause distortion in the picture due to their strong magnets. This distortion, however, will not harm the picture tube.

For maximum enjoyment and safe operation of your MITSUBISHI Color TV, please read the "IMPORTANT SAFEGUARDS" carefully and apply them properly.

► **Warning:**

Don't lift the TV by the speakers.

Calling for service

If you are unable to correct the problem, consult your MITSUBISHI dealer or MITSUBISHI Authorized Warranty Service Center.

Do not adjust any controls not described in this owner's guide.

Do not remove the protective back cover of this unit.

If you see the following display on your screen, you should not change any settings. This is a special display used by the factory.

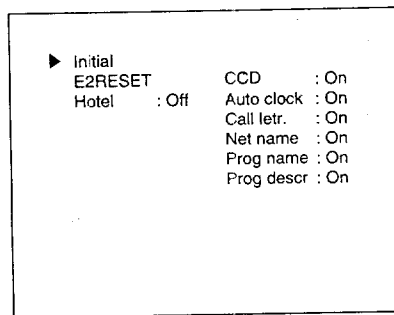

If this display appears, make sure that all of the on/off settings are the same as the illustration above and then turn the TV off. If any of the settings are different than the illustration above, turn the TV off and consult your MITSUBISHI dealer or MITSUBISHI Authorized Warranty Service Center.



Cut along dotted line and file after reading ✓

100

You will need to enter the code when:

- ① viewing the locked TV, or
- ② canceling the lock.

If you forget the code, you can cancel or view the locked TV without entering the code. To do this, simply press the buttons labeled "Q.V." and "9" at the same time.

▷ **Important:** Unlocking with this procedure is only temporary. After finishing the procedure, follow the instructions shown in "Using the parental lock" in Chapter 3 to cancel or view the locked TV.



Index

A

active A/V Network terminal 27
Adding and deleting channels 61
adjust (up/down) buttons 17, 23, 24
Adjusting the color purity 47
Adjusting the picture 70
 adjusting the brightness
 adjusting the color
 adjusting the sharpness
 adjusting the tint
 changing the color bias
 changing the color temperature
 changing the contrast
 reducing the video noise
 setting closed captioning
Adjusting the sound 68
 adjusting the balance
 adjusting the bass
 adjusting the treble
 setting the level sound to on/off
 setting the monitor mode
 setting the reception mode
 setting the speaker to internal/external
 turning the audio expansion on/off
antenna terminals 26
audio and video controls 17, 22
audio function button (AUDIO) 17, 22
audio input terminals 18, 27
audio monitor output terminals 27
audio tuner output terminals 27
Automatic Procedure for the Parental Lock 101
A/V reset button (A/V RESET) 16

B

Basic Connections 28
 TV+antenna or cable with a decoder box 31

 TV+antenna or cable without a decoder box 30
 TV+audio system 42
 TV+external speakers 29
 TV+home theater receiver (A/V receiver) 40
 TV+Mitsubishi products that have A/V Network terminals 43
 TV+separate UHF and VHF antennas 33
 TV+VCR+antenna or cable with a decoder box 37
 TV+VCR+antenna or cable without a decoder box 34

C

Calling for Service 99
cancel button (CANCEL) 23
Caution and Care 98
Changing channels 54
Changing or canceling the off-timer 83
channel controls (CHANNEL) 17, 22
color purity adjustment switches 16
Connecting Your TV 25
 Basic connections 28
 Overview of the Back Panel 26

D

degauss button (DEGAUSS) 18
Deleting channels 61
display button (DISPLAY) 23

E

enter button (ENTER) 22
external speaker terminals 26

F

Freezing the PIP image 88

G

Getting ready to use the remote control 19
 general instructions 20
 guidelines for using batteries 20

 installing the batteries 19
 some dos and don'ts 20
Getting Started 46
 Adding and deleting channels 61
 Adjusting the color purity 47
 Adjusting the picture 70
 Adjusting the sound 68
 Changing channels 54
 Memorizing channels 60
 Renaming the inputs 63
 Selecting the input source 53
 Selecting language 64
 Setting the A/V Network 62
 Setting the clock 58
 Turning the TV on/off 52
 Understanding the on-screen menus 57
 Using the advanced PIP functions 67
 Using the closed caption decoder 72
 Using the power restore feature 66
 Using the remote control 48
 Using video mute 65
Getting to Know Your TV 15
 Overview of the Control Panel 16
 Overview of the Remote Control 19

H

home button (HOME) 23

I

Important Safeguards 3
input button (INPUT) 17, 22
installing the batteries 19

M

Memorizing channels 60
menu button (MENU) 23
Moving the PIP image 87
mute control (MUTE) 22

N

number buttons 24

O

off timer button (OFF-T) 24

Operating Your TV 45

Getting Started 46

Using the Advanced Features 73

Overview of the Back Panel 26

Overview of the Control Panel

16

Overview of the Remote control

19

Getting ready to use the remote control 19

Remote control buttons and functions 21

P

picture-in-picture controls 24

power button (POWER) 16, 22

program timer indicator (PROGRAM TIMER) 18

Q

quick view button (QV) 22

quick program button 24

R

Renaming the inputs 63

Remote control buttons and functions 21

right/left buttons 23, 24

S

select buttons 22

Selecting language 64

Selecting the channel (PIP mode) 86

Selecting the PIP image 85

Selecting the input source 53

Selecting the source (PIP mode) 86

Setting the A/V Network 62

Setting the clock 58

Setting the off-timer 82

Setting the timer 74

Some Conventions Used in This Guide 13

Summary of Special Features

10

super quick view button (SQV) 22

S-VIDEO input terminal 18, 26

S-video monitor output terminal 27

T

Troubleshooting 95

Calling for Service 99

Caution and Care 98

Turning the TV on/off 52

TV+antenna or cable with a decoder box 31

TV+antenna or cable without a decoder box 30

TV+audio system 42

TV+external speakers 29

TV+home theater receiver (A/V receiver) 40

TV+Mitsubishi products that have A/V Network terminals 43

TV+separate UHF and VHF antennas 33

TV+VCR+antenna or cable with a decoder box 37

TV+VCR+antenna or cable without a decoder box 34

U

Unpacking Your TV 11

Understanding the On-Screen Displays 80

Understanding the on-screen menus 57

Using the Active A/V Network Feature 91

Using the advanced PIP functions 67

Using the Advanced Features 73

Setting the timer 74

Using the parental lock 75

Using the Super Quick View tuning 77

Using the closed caption decoder 72

Using the Off-Timer 81

Changing or canceling the off-timer 83

Setting the off-timer 82

Using the parental lock 75

Using the Picture-in-Picture (PIP) Mode 84

Freezing the PIP image 88

Moving the PIP image 87

Selecting the channel 86

Selecting the PIP image 85

Selecting the source 86

Using the Replay feature 90

Using the Snap-shot feature 89

Using the power restore feature 66

Using the remote control 48

Using the Replay feature 90

Using the Snap-shot feature 89

Using the Special Features 79

Understanding the On-Screen Displays 80

Using the Active A/V Network Feature 91

Using the Off-Timer 81

Using the Picture-in-Picture (PIP) Mode 84

Using the Super Quick View tuning 77

Using video mute 65

V

video function button (VIDEO) 17, 23

video input terminal 18, 27

video monitor output terminal 27

video tuner output terminal 27

volume controls (VOL, VOLUME) 17, 22

W

What's in Each Chapter 12



MITSUBISHI ELECTRONICS AMERICA, INC.
6100 Atlantic Boulevard
Norcross, GA 30071-1305