

 MITSUBISHI

TS-50611
VS-55601
VS-60601
VS-60621
VS-70601

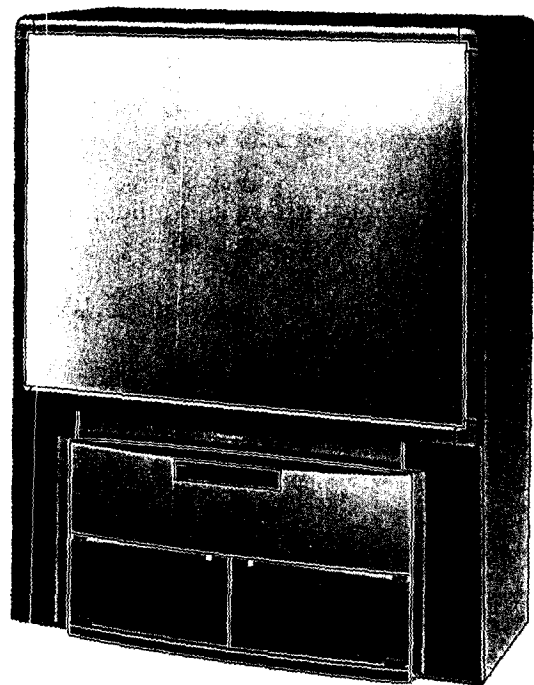

Projection
TV
Owner's
Guide

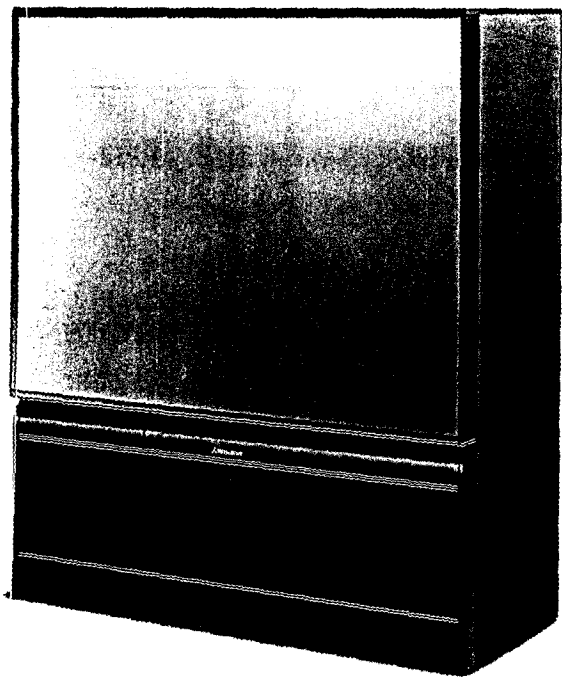

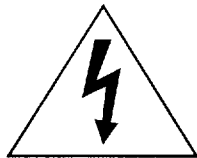

CAUTION

RISK OF ELECTRIC SHOCK
DO NOT OPEN



CAUTION: TO REDUCE THE RISK OF ELECTRIC SHOCK,
DO NOT REMOVE COVER (OR BACK).
NO USER-SERVICEABLE PARTS INSIDE.
REFER SERVICING TO QUALIFIED SERVICE PERSONNEL.

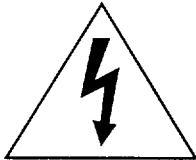

The lightning flash with arrowhead symbol within an equilateral triangle is intended to alert the user to the presence of uninsulated "dangerous voltage" within the product's enclosure that may be of sufficient magnitude to constitute a risk of electric shock.



The exclamation point within an equilateral triangle is intended to alert the user to the presence of important operating and maintenance (servicing) instructions in the literature accompanying the appliance.

► **Warning:**

Don't leave stationary images, such as stock market reports, video games, station logos, or the TV's displays, on-screen for more than 10 minutes. Still patterns such as these can scar the picture tube, causing permanent damage to the TV.

WARNING:

TO REDUCE THE RISK OF FIRE OR ELECTRIC SHOCK, DO NOT EXPOSE THIS APPLIANCE TO RAIN OR MOISTURE.

CAUTION:

TO PREVENT ELECTRIC SHOCK HAZARD, DO NOT USE THIS UNIT'S (POLARIZED) PLUG WITH AN EXTENSION CORD, RECEPTACLE OR OTHER OUTLET UNLESS THE BLADES CAN BE FULLY INSERTED TO PREVENT BLADE EXPOSURE.

NOTE TO CATV SYSTEM INSTALLER:

THIS REMINDER IS PROVIDED TO CALL THE CATV SYSTEM INSTALLER'S ATTENTION TO ARTICLE 820-40 OF THE NEC THAT PROVIDES GUIDELINES FOR PROPER GROUNDING AND, IN PARTICULAR, SPECIFIES THAT THE CABLE GROUND SHALL BE CONNECTED TO THE GROUNDING SYSTEM OF THE BUILDING, AS CLOSE TO THE POINT OF CABLE ENTRY AS PRACTICAL.



Table of Contents

Important Safeguards 3

Preface: Welcome to Mitsubishi 5

Summary of Special Features 6

Unpacking Your TV 7

What's in Each Chapter 8

Some Conventions Used in this Guide 9

Chapter 1: Getting to Know Your TV 11

Overview of the Control Panel 12

Overview of the Remote Control 14

 Getting ready to use the remote control 14

 Remote control buttons and functions 16

Chapter 2: Connecting Your TV 19

Overview of Back Panel 20

Basic Connections 22

 TV + antenna or cable without a cable box 23

 TV + cable with a cable box 24

 TV + separate UHF and VHF antennas 26

 TV + VCR + antenna or cable without a cable box 27

 TV + VCR + cable with a cable box 30

 TV + stereo audio system 36

 TV + Mitsubishi products that have A/V Network
 Terminals 37

Chapter 3: Operating Your TV 39

Getting Started 40

 Using the remote control to operate VCRs, cable
 boxes and other equipment 41

 Turning the TV on/off 47

 Selecting the input source to watch your VCR
 or other equipment 48

 Changing channels 49

 Understanding the ViewPoint® on-screen menus 53

 Setting the clock 54

 Memorizing channels 57

 Adding and deleting channels 58

 Setting the A/V Network 59

 Adjusting the convergence 60

 Selecting the menu type 61

Chapter 3: Operating Your TV (cont.)

Naming the input.....	63
Naming the channels.....	64
Using video mute.....	66
Selecting the menu language.....	67
Selecting the A/V memory categories.....	68
Customizing the A/V memory settings.....	70
Using the Advanced Features.....	79
Setting the timer.....	80
Using the parental lock.....	81
Using SuperQuickView™.....	85

Chapter 4: Using the Special Features 87

Understanding the On-Screen Displays.....	88
Using the Sleep Timer.....	89
changing or cancelling the sleep timer.....	90
Using the Picture-in-Picture (PIP) Modes.....	91
activating the PIP image.....	92
selecting the source of the PIP image.....	93
changing channels while using the PIP modes.....	94
exchanging the picture of the PIP image and the main image.....	95
freezing the PIP image.....	96
Using the Active A/V Network Feature.....	97

Chapter 5: Troubleshooting 99

caution and care.....	103
cleaning.....	103
calling for service.....	104

Appendix: Procedure for Bypassing the Parental Lock 105

Index..... 107

IMPORTANT SAFEGUARDS

PLEASE READ ALL THESE INSTRUCTIONS REGARDING YOUR TELEVISION SET AND RETAIN FOR FUTURE REFERENCE. FOLLOW ALL WARNINGS AND INSTRUCTIONS MARKED ON THE TV RECEIVER.

1. Read Instructions

Read all safety and operating instructions before operating the appliance.

2. Retain Instructions

Retain the safety and operating instructions for future reference.

3. Heed Warnings

Adhere to all warnings on the appliance and in the operating instructions.

4. Follow Instructions

Follow all operating and use instructions.

► Warning:

5. Cleaning

Unplug this TV receiver from the wall outlet before cleaning. Do not use liquid or aerosol cleaners. Cleaners can permanently damage the cabinet or screen. Use a damp cloth for cleaning.

6. Attachments and Equipment

Never add any attachments and/or equipment without approval of the manufacturer as such additions may result in the risk of fire, electric shock or other personal injury.

7. Water and Moisture

Do not use this TV receiver where contact with or immersion in water is possible. Do not use near bath tubs, wash bowls, kitchen sinks, laundry tubs, swimming pools, etc.

8. Accessories

Do not place this TV receiver on an unstable cart, stand, tripod, bracket, or table. The TV receiver may fall, causing serious injury to a child or adult, and serious damage to the appliance. Use only with a cart, stand, tripod, bracket, or table recommended by the manufacturer, or sold with the TV receiver. Any mounting of the appliance should follow the manufacturer's instructions, and should use a mounting accessory recommended by the manufacturer.

An appliance and cart combination should be moved with care. Quick stops, excessive force, and uneven surfaces may cause the appliance and cart combination to overturn.



9. Ventilation

Slots and openings in the cabinet are provided for ventilation and to ensure reliable operation of the TV receiver and to protect it from overheating. Do not block these openings or allow them to be blocked by placing the TV receiver on a bed, sofa, rug, or other similar surface. Nor should it be placed over a radiator or heat register. If the TV receiver is to be placed in a rack or bookcase, ensure that there is adequate ventilation and that the manufacturer's instructions have been adhered to.

10. Power Sources

This TV receiver should be operated only from the type of power source indicated on the marking label. If you are not sure of the type of power supplied to your home, consult your appliance dealer or local power company.

11. Grounding or Polarization

This TV receiver is equipped with a polarized alternating current line plug having one blade wider than the other. This plug will fit into the power outlet only one way. If you are unable to insert the plug fully into the outlet, try reversing the plug. If the plug should still fail to fit, contact your electrician to replace your obsolete outlet. Do not defeat the safety purpose of the polarized plug.

12. Power-Cord Protection

Power-supply cords should be routed so that they are not likely to be walked on or pinched by items placed upon or against them, paying particular attention to cords at plugs, convenience receptacles, and the point where they exit from the appliance.

13. Lightning

For added protection for this TV receiver during a lightning storm, or when it is left unattended and unused for long periods of time, unplug it from the wall outlet and disconnect the antenna or cable system. This will prevent damage to the TV receiver due to lightning and power-line surges.

Important Safeguards (cont.)

14. Power Lines

An outside antenna system should not be located in the vicinity of overhead power lines or other electric light or power circuits, or where it can fall into such power lines or circuits. When installing an outside antenna system, extreme care should be taken to keep from touching such power lines or circuits as contact with them might be fatal.

15. Overloading

Do not overload wall outlets and extension cords as this can result in a risk of fire or electric shock.

16. Object and Liquid Entry

Never push objects of any kind into this TV receiver through openings as they may touch dangerous voltage points or short-out parts that could result in a fire or electric shock. Never spill liquid of any kind on the TV receiver.

17. Outdoor Antenna Grounding

If an outside antenna or cable system is connected to the TV receiver, be sure the antenna or cable system is grounded so as to provide some protection against voltage surges and built-up static charges.

Section 810 of the National Electrical Code, ANSI/NFPA No. 70-1984, provides information with respect to proper grounding of the mast and supporting structure, grounding of the lead-in wire to an antenna discharge unit, size of grounding conductors, location of antenna discharge unit, connection to grounding electrodes, and requirements for the grounding electrode.

EXAMPLE OF ANTENNA GROUNDING

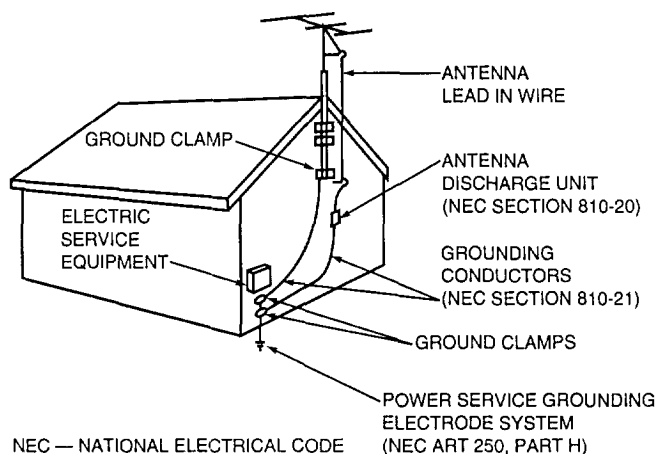

18. Servicing

Do not attempt to service this TV receiver yourself as opening or removing covers may expose you to dangerous voltage or other hazards. Refer all servicing to qualified service personnel.

19. Damage Requiring Service

Unplug this TV receiver from the wall outlet and refer servicing to qualified service personnel under the following conditions:

- When the power-supply cord or plug is damaged
- If liquid has been spilled, or objects have fallen into the TV receiver
- If the TV receiver has been exposed to rain or water
- If the TV receiver does not operate normally by following the operating instructions, adjust only those controls that are covered by the operating instructions as an improper adjustment of other controls may result in damage and will often require extensive work by a qualified technician to restore the TV receiver to its normal operation.
- If the TV receiver has been dropped or the cabinet has been damaged
- If the TV receiver exhibits a distinct change in performance — this indicates a need for service

20. Replacement Parts

When replacement parts are required, be sure the service technician has used replacement parts specified by the manufacturer or have the same characteristics as the original part. Unauthorized substitutions may result in fire, electric shock or other hazards.

21. Safety Check

Upon completion of any service or repairs to this TV receiver, ask the service technician to perform safety checks to determine that the TV receiver is in safe operating condition.

► Warning:

Do not leave stationary images, such as stock market reports, video games, station logos, or the TV's displays, on-screen for more than 10 minutes. Still patterns such as these can scar the picture tube, causing permanent damage to the TV.



Congratulations on your purchase of this Mitsubishi TV. Your TV is designed for superb viewing pleasure as well as continued reliability.

To familiarize you with your TV and owner's guide, we suggest that you read through the preface, which provides the following important information:

- ◆ **Summary of Special Features**
- ◆ **Unpacking Your TV**
- ◆ **What's in Each Chapter**
- ◆ **Some Conventions Used in this Guide**

Mitsubishi has designed your TV to bring you years of viewing enjoyment. Similarly, your owner's guide is designed to be user friendly, providing guidance to help you take advantage of all of your equipment features.

Thank you for selecting our product and once again, welcome to Mitsubishi!

◆ Summary of Special Features

Your top-rated Mitsubishi TV delivers the following special features:

- **TV GUIDE Plus+** --- a subscription-free, interactive, on-screen program guide. It is integrated directly into the signal of the TV channel and updated automatically several times a day.
- **181-Channel Capacity** --- programs up to 181 channels (either 68 antenna channels or 125 cable channels).
- **Illuminated Multibrand Remote Control with TV/VCR/DVD/AUDIO Control** --- uses a single remote control transmitter to operate the TV, selected Mitsubishi VCRs, DVD player and audio components, as well as certain VCRs, cable boxes, and satellite receivers from other manufacturers.
- **ViewPoint® On-Screen Operating System** --- simplifies the TV's features with easy-to-follow instructions.
- **Digital Dynamic Comb Filter** --- creates a smooth, continuous picture texture, by comparing the individual scanning lines with those directly above and below.
- **Color Temperature Control** --- Provides 3 choices, including a precise 6500°K setting for optimum color tones.
- **Front Reflective Surface Mirror** --- provides sharper and brighter pictures by reflecting all light from the front surface.
- **Intelligent Room Illumination Sensor (IRIS)™** ---automatically adjusts brightness and contrast for an optimum picture at all times.
- **5-Point Digital Convergence** --- allows you to finely adjust the color convergence at 5 different positions.
- **Closed Caption Decoder** --- decodes hidden text information included with TV programs and displays the text on-screen.
- **Extended Data Services** --- (also known as "XDS") allows broadcasters to supply you with channel information, program information, and the time of day.
- **2-Tuner Advanced Picture-in-Picture Mode** --- allows you to view two different broadcasts at the same time without using a VCR tuner.
- **Expanded Sound Capability** --- allows you to connect the TV to an external audio system for enhanced listening pleasure. Also, includes **Level Sound** to equalize differing program and channel volume levels.
- **Active A/V Network** --- allows you to perform many of the commonly used features of your TV and selected Mitsubishi VCRs by pressing a single button.

▷ **Important:** The entire range of these special features is integrated into your Mitsubishi TV and fully operational - whether or not you connect your IR emitter.

- ④ Place the TV on a stable surface with sufficient lighting to do the hook-up.

◆ Unpacking Your TV

What you will find

As you unpack your new TV, please check to be sure the following items are included:

- an owner's guide containing a warranty
- a registration card
- a remote control transmitter
- a set of two AAA size batteries for the remote control
- an Active A/V Network cable
- IR emitter for TV GUIDE Plus+ features



A few suggestions

Before you hook up your new TV, please take a few minutes to:

- ❶ Complete the registration card. The registration card asks for the serial number of the TV. You will find this on the back of the unit.
- ❷ Keep the box and packing materials for future use.
- ❸ File your sales receipt in a safe place. It may be required for warranty service.
- ❹ Place the TV on a stable surface with sufficient lighting to do the hook-up.

◆ What's in Each Chapter

Here's what you will find in this owner's guide:

Chapter 1, *Getting to Know Your TV*

Introduction to the locations and functions of the buttons and controls of your TV

Chapter 2, *Connecting Your TV*

Instructions for connecting a VCR, antenna, cable box and other equipment to your TV

Chapter 3, *Operating Your TV*

Guidance for using your Mitsubishi TV to achieve maximum viewing satisfaction. Procedures that are unique to the operation of TV Guide Plus+ are highlighted. See the *TV GUIDE Plus+ Operating Guide* for instructions on using the TV GUIDE Plus+ feature.

Chapter 4, *Using the Special Features*

Operating instructions for using the advanced functions of your Mitsubishi TV

Chapter 5, *Troubleshooting*

Summary of problems you might encounter and suggestions for resolving them

The appendix explains the procedure for bypassing the parental lock.

You will also find a detailed index at the back of the book.

◆ Some Conventions Used in this Guide

Mitsubishi has gone to great effort to provide you with an easy-to-follow, useful owner's guide. You will find that different types of information are treated in different ways.

You should pay particular attention to topics bulleted by a red arrow and either an Important or a Warning label. These terms are used sparingly in the owner's guide. They are intended to highlight information which should be carefully read.

If you will be activating TV GUIDE Plus+, take careful note of all information with the TV GUIDE Plus+ signal cues. These directions are exclusively for your use. They should not be followed or used if you will not be using this feature.

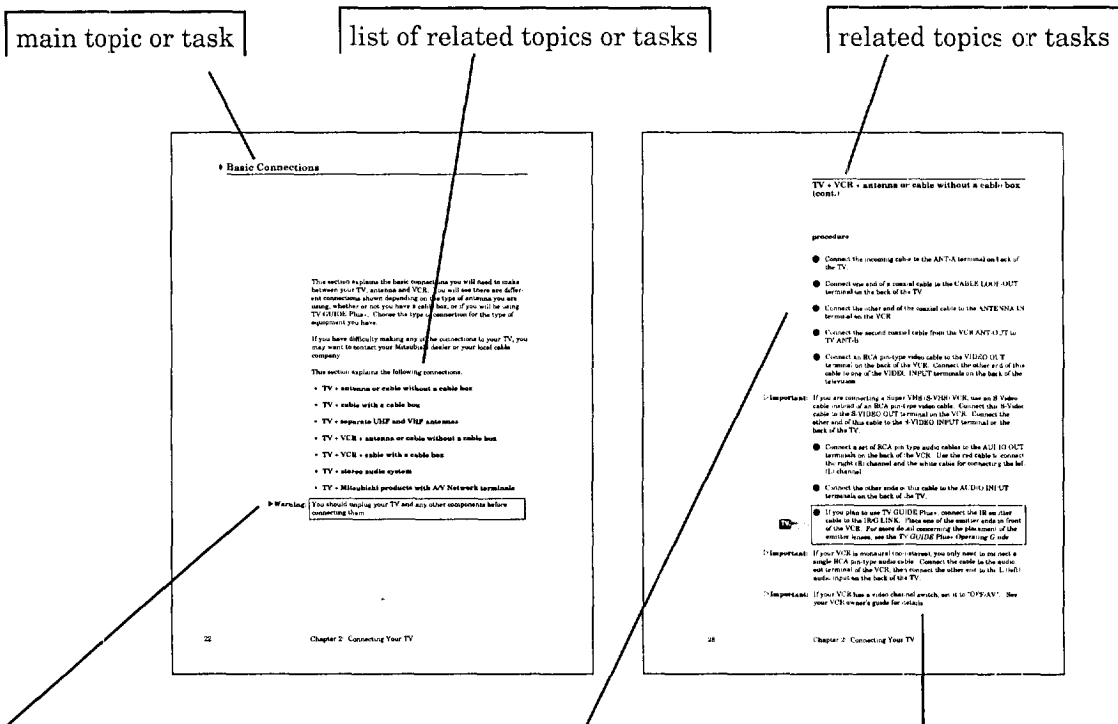

▶ **Warning**

This cue alerts you to information describing dangerous situations that could damage your equipment or cause electrical shock.

1, 2, etc.

The step-by-step instructions on how to accomplish a particular task are signaled by white numbers on a black background.

▶ **Important:**

This cue indicates information critical to the operation of your new TV.



TV GUIDE Plus+ signal cue. Information is exclusively for TV GUIDE Plus+ users.



Now that you have unpacked your TV, read through the safety information and glanced at the overview of how this owner's guide is organized, it's time to become familiar with the buttons and controls you will be using when you operate the TV. This chapter will introduce the range of options available when using the buttons on the remote control or on the TV's control panel. It also offers some general guidelines for using the remote control.

Most functions can be controlled by using either the control panel or the remote control, but certain specialized functions require the use of one or the other. This chapter, which will familiarize you with the full range of button functions, contains the following sections:

- ◆ **Overview of the Control Panel**
- ◆ **Overview of the Remote Control**

◆ Overview of the Control Panel

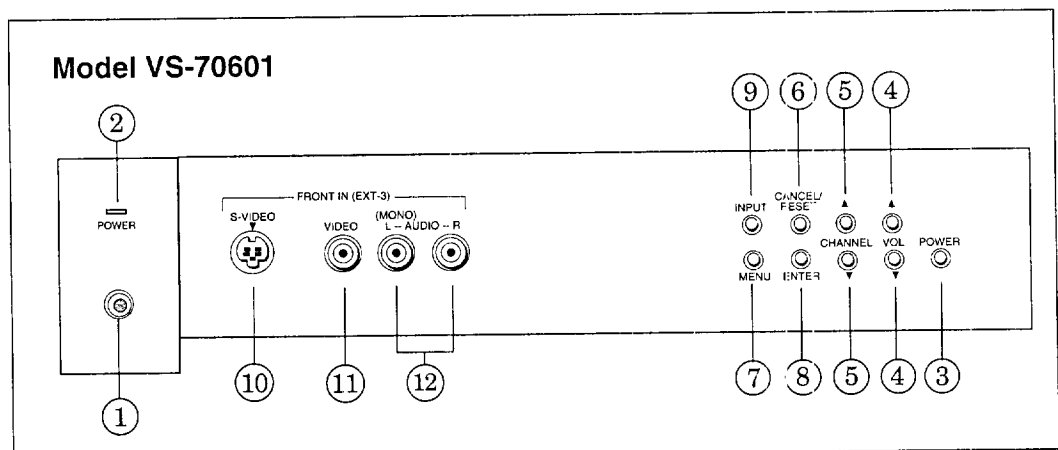
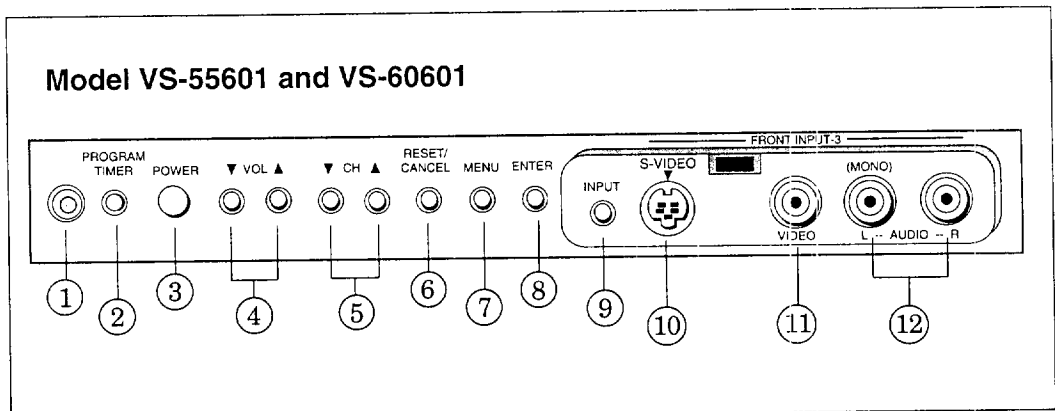
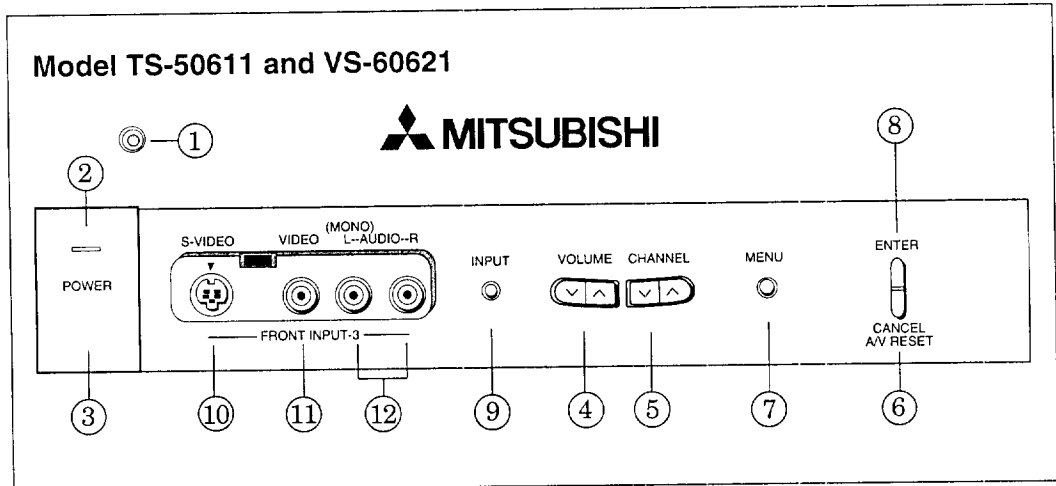

Overview of the Control Panel (cont.)

- ① **intelligent room illumination sensor (IRIS)[™]**
This sensor regulates the automatic contrast and brightness adjustment for the IRIS feature. See “Customizing the A/V memory settings” in Chapter 3.
- ② **power, or program timer indicator (POWER) (PROGRAM TIMER)**
This indicator lights up in green when you turn the TV on. It blinks in green when the TV is off and the timer has been set.
- ③ **power button (POWER)**
Use to turn the TV on or off.
- ④ **volume controls (VOLUME or VOL ▲ ▼)**
Press the (▲) button to increase the volume. It is also used to make right adjustments in some menus. The (▼) button decreases the volume and is used for left adjustments in some menus.
- ⑤ **channel controls (CHANNEL or CH ▲ ▼)**
Use the (▲) button to switch to a channel with a higher number and the (▼) button to switch to a channel with a lower number. This button will also adjust the alignment in the “Convergence” menu and can be used to move up (▲) or down (▼) in the menu mode.
- ⑥ **cancel/reset button (CANCEL/RESET or A/V RESET)**
Can be used as CANCEL when using an on-screen menu and as A/V RESET in normal TV viewing.
- (CANCEL) This button is used to clear the settings of some on-screen menus. It can also be used for Guide Plus+ installation as explained in *TV Guide Plus+ Operating Guide*.
- (RESET or A/V RESET) Press to reset all audio and video functions to their original factory adjustments or setting except for volume, the “Listen to” function (Stereo/SAP/Mono), speaker (off/on), monitor out (variable/fixed), background (black/gray), IRIS, Instant Info, and closed captioning.
- ⑦ **menu button (MENU)**
Use this button to display the on-screen menu system, which contains additional instructions for special functions.
- ⑧ **enter button (ENTER)**
Use this button after selecting an item from the on-screen menu system.
- ⑨ **input button (INPUT)**
Use to select the input source you wish to view:
- TV channels on Antenna A (Ant-A) or Antenna B (Ant-B) and /or
 - other equipment connected to Input 1, 2, or 3
- ⑩ **S-video input terminal**
Use to connect the S-video output of a camcorder or other component to the TV. If you connect an S-video cable to this terminal, the adjacent video input terminal cannot be used.
- ⑪ **video input terminal**
Use to connect the video output from a standard camcorder or other component to the TV.
- ⑫ **audio input terminals**
Use to connect the audio output from a camcorder or other component.

◆ Overview of the Remote Control

This section provides you with an overview of the remote control's buttons and the features that they control.

This section does not provide detailed explanations on the use of these buttons. To determine which buttons are used with a particular feature, refer to the instructions for that feature. Features are listed by name in the Index at the end of this guide.

Getting ready to use the remote control

installing the batteries

- 1 Take the two AAA size batteries from the packing bag.
- 2 Remove the back cover of the remote control by pushing the tab in the direction of the arrow and lifting off the cover.
- 3 Insert batteries.
- 4 Replace cover.

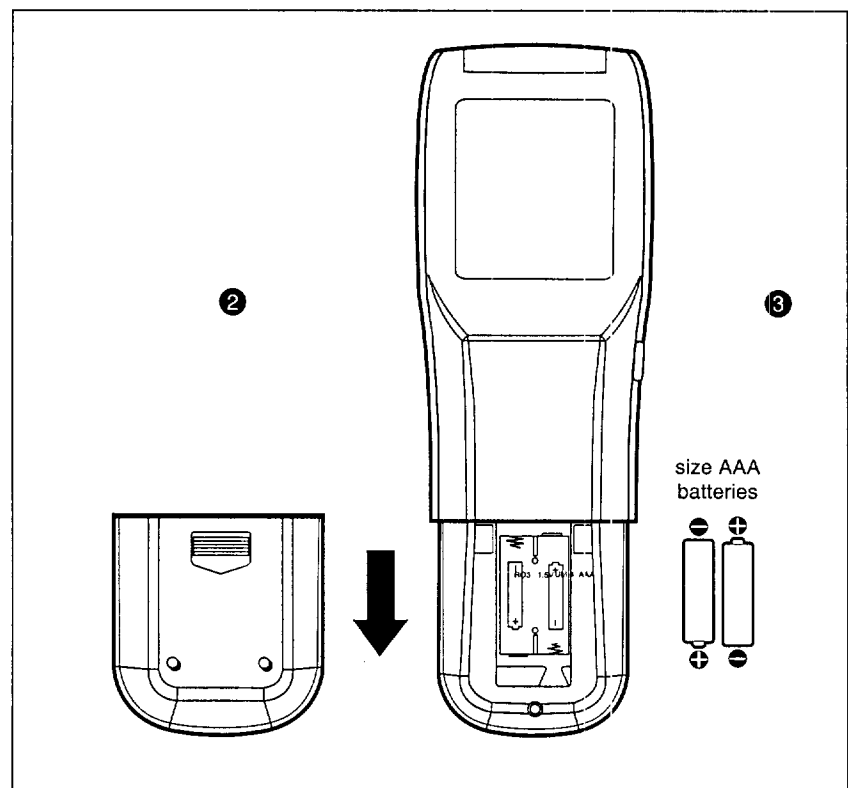

Getting ready to use the remote control (cont.)

some do's and don'ts

To ensure that your remote control will continue working properly, follow these guidelines:

- Don't press two or more buttons at the same time, unless you are specifically instructed to do so in this owner's guide.
- Don't allow the remote control to get wet or become heated.
- Avoid dropping the remote control on a hard surface.
- When cleaning the remote control, don't use any harsh chemicals. Use only a soft, slightly moistened cloth.

general instructions

When using the remote control to operate the TV, VCR, DVD, Cable box, or audio equipment:

- ❶ Be within 20 feet of the equipment.
- ❷ Point the tip of the remote control toward the equipment.
- ❸ Press the appropriate button or sequence of buttons.

guidelines for using batteries

- Don't use a new battery with an old one.
- Don't heat, take apart, or throw batteries into a fire.
- Load the batteries as indicated in the illustration, making sure that they are positioned correctly (+ to +, and - to -).
- Replace the back cover of the remote control.

For best results, use Duracell* AAA (MN2400) batteries.

**Duracell® is a registered trademark of Duracell, Inc.*

Remote control buttons and functions

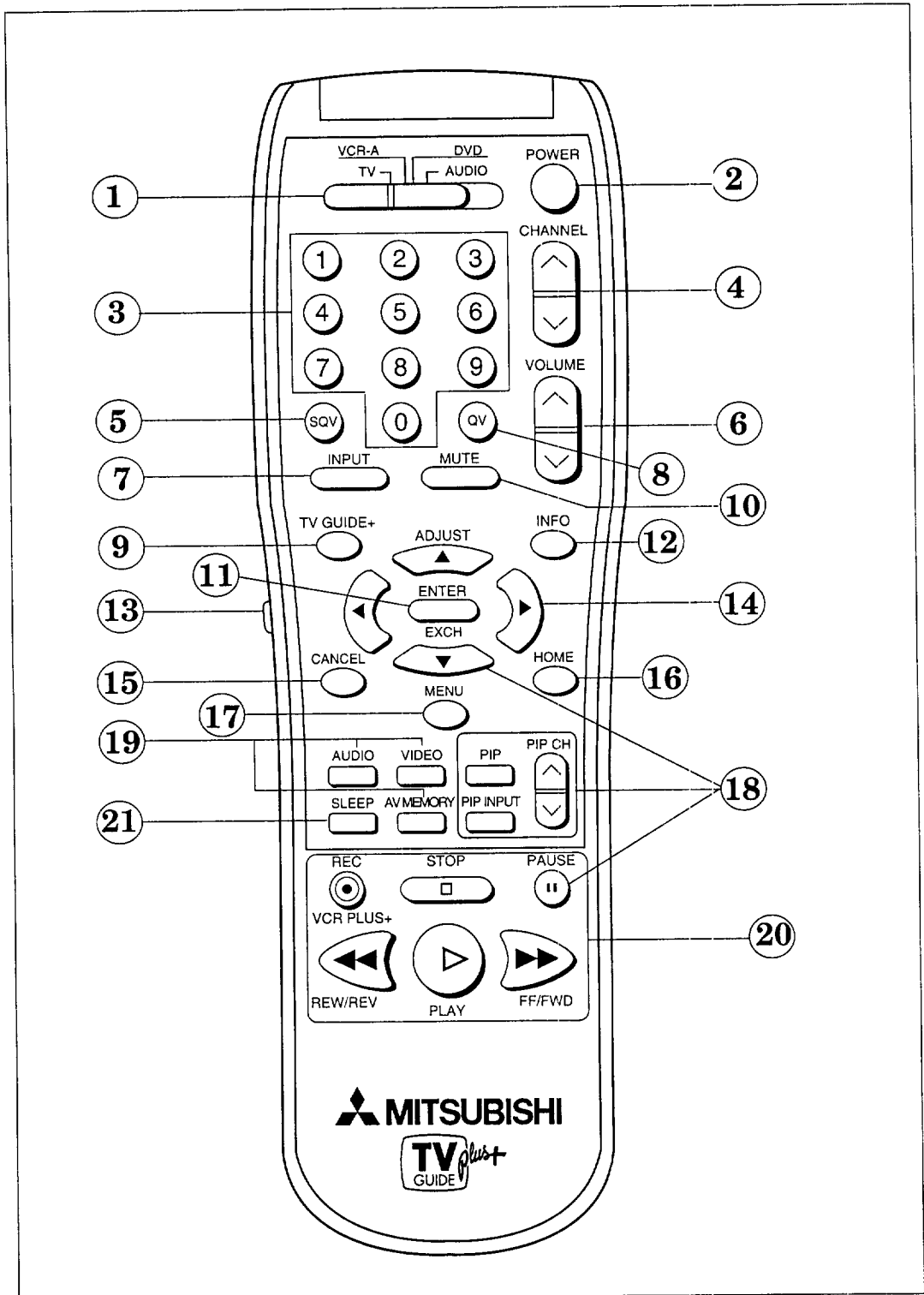

Remote control buttons and functions (cont.)

① select switch

Your remote control has four layers: the TV layer, the VCR-A layer, the DVD layer, and the AUDIO layer. You can set up each of these layers to operate a different piece of equipment. Use this switch to select the layer you want to set up or use.



② power button (POWER)

Press this switch to turn the TV on or off.

③ number buttons (0-9)

Use to select a channel number or to enter a parental lock code, OR

to enter zip codes for TV GUIDE Plus+ setup.

④ channel control (CHANNEL)

Press the top part of the button to change to a channel with a higher number; press the bottom part to change to a channel with a lower number.

⑤ SuperQuickView™ button (SQV)

Press to view channels you have programmed into SuperQuickView™ memory.

⑥ volume control (VOLUME)

Press the top part of the button to increase the volume. Press the bottom part of the button to decrease the volume.

⑦ input button (INPUT)

Use to select the input source you wish to watch:

- TV channels on Antenna A or Antenna B
- Other equipment connected to Input 1, 2 or 3.

⑧ QuickView™ button (QV)

Press this button to instantly switch to the channel that you designated as the QuickView channel. Press again to return to the last channel viewed.

⑨ TV GUIDE Plus+ (TV GUIDE+)

Use this button to display TV GUIDE Plus+ program listings.

▷ Important:

TV GUIDE Plus+ must be activated to operate this button. See the TV GUIDE Plus+ Operating Guide.

⑩ mute control (MUTE)

Use to turn the sound off completely or to restore it to its original volume.

⑪ enter/exchange button (ENTER/EXCH)

Use this button after selecting a channel number, after selecting an item from the onscreen menu system, or with the picture-in-picture mode.

⑫ information button (INFO)

Use to view an onscreen summary of the current settings for the TV or AUDIO functions and the display related to Extended Data Services (XDS).

This button is also used extensively in the GUIDE Plus+ menu system. See the TV GUIDE Plus+ Operating Guide.

⑬ light button

Use to light up the remote (for four seconds).

⑭ adjust buttons (▲, ▼, ◀, ▶)

After selecting an audio or video function, use these buttons to adjust the sound or picture. Also use these with the picture-in-picture mode to move the PIP location on the screen and to select items in the menus.

ADJUST buttons may be used to scroll through the channels in GUIDE Plus+ menus.

Remote control buttons and functions (cont.)

⑮ cancel button (CANCEL)

This button is used to cancel a channel number, to clear a channel programmed into SuperQuickView™ memory, and to clear the settings of some onscreen menus.



It is also used to stop TV GUIDE Plus+ installation.

⑯ home button (HOME)

Press to return to regular TV viewing from the onscreen menus, to turn off the onscreen displays, and to cancel the closed captioning.



Also turns off TV GUIDE Plus+ displays.

⑰ menu button (MENU)

Use this button to display the TV's on-screen menu system, which contains additional instructions for special functions.

⑱ picture-in-picture controls

Use to control the special picture-in-picture (PIP) function.

- **PIP button (PIP)** -- Press to turn on the PIP image, to change its size, or to cancel it.
- **PIP channel button (PIP CH)** -- Press to change the channel of the PIP image
- **PIP input button (PIP INPUT)** -- Press repeatedly to switch the source of the PIP image between the TV and the external inputs.
- **pause button (PAUSE)** -- Press to freeze the reduced PIP image and to return to a "live" image.
- **exchange button (EXCH)** -- Press to exchange the PIP and the main images.



⑲ audio and video controls

Use the AUDIO button or VIDEO button to select one of the settings listed below.

• audio function button (AUDIO)

- stereo/SAP/mono
- bass
- treble
- balance
- surround off/simulate/hall
- speaker on/off
- monitor out variable/fixed
- level sound off/on

• video function button (VIDEO)

- tint
- color
- contrast
- brightness
- sharpness
- color temperature low/middle/high
- background black/gray
- Instant Info on/off
- IRIS on/off

• audio video memory (A/V MEMORY)

Use this button for immediate access to A/V memory selections.

⑳ VCR and audio product function buttons

Use these buttons to control VCRs, cassette decks, CD players, etc. These are pre-programmed to operate selected Mitsubishi components.

The PLAY button is also used with the Active A/V Network. See "Using the Active A/V Network Feature" in Chapter 4.

The REC button in the TV layer is the VCR Plus+ key which brings up the VCR Plus+ menu. The VCR Plus+ key can be used to register a recording event.

㉑ sleep timer button (SLEEP)

Use to program the TV to turn off automatically at a later time.

This chapter offers step-by-step instructions for completing the most common hook-ups. It contains the following sections:

- ◆ **Overview of the Back Panel**
- ◆ **Basic Connections**

◆ Overview of the Back Panel

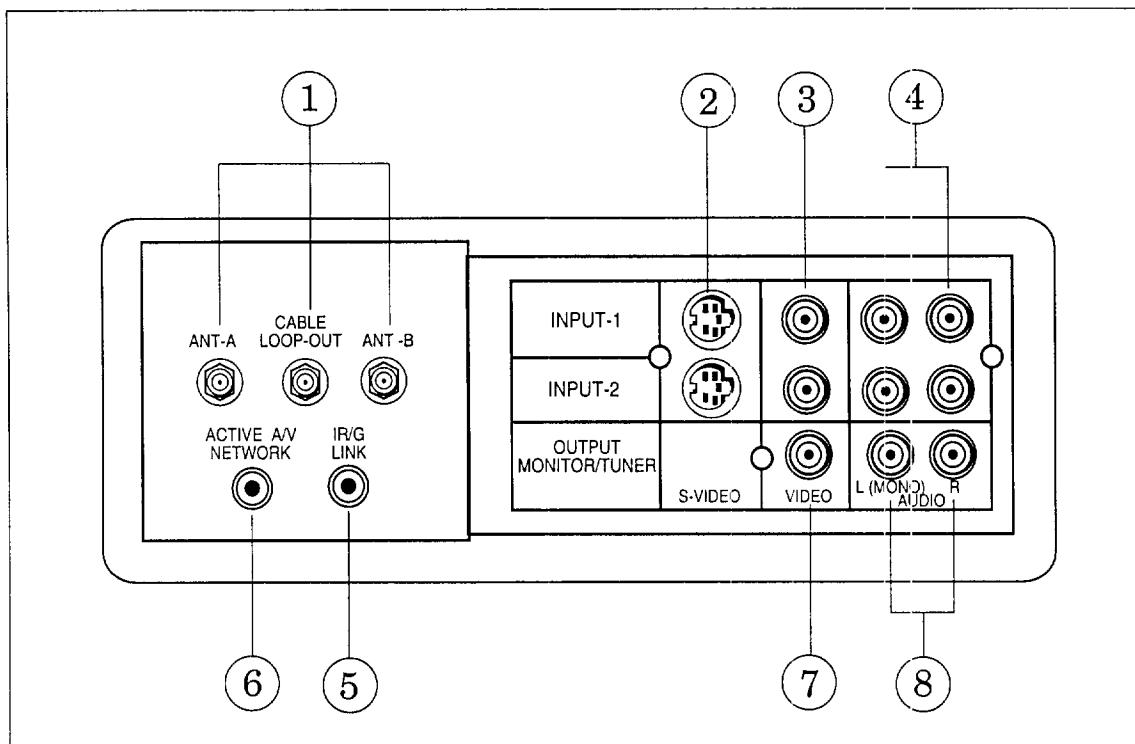

① antenna terminals (ANT-A, CABLE LOOP-OUT, ANT-B)

Two independent cables or antennas can be connected to these terminals. Use ANT-A and ANT-B terminals to receive a signal from VHF/UHF antennas or your cable system. Use the CABLE LOOP OUT terminal to send the signal being received by the ANT-A terminal out to another component (such as a VCR).



The TV GUIDE Plus+ signal source **MUST** be connected to the ANT-A terminal.

Overview of the back panel (cont.)

② **S-VIDEO input terminal**

Use these terminals to connect an S-video signal from a Super VHS (S-VHS) VCR or disc player to the TV.

▷ **Important:** If you connect either of the S-Video jacks, you cannot use the adjacent standard video jack for that same input.

③ **video input terminals**

Use these terminals to connect the video output from a standard VCR or other component to the TV.

④ **audio input terminals**

Use these terminals to connect the audio output from a VCR or other component to the TV.

⑤ **IR/G link**

Use this terminal to connect an Infrared (IR) Emitter for TV GUIDE Plus+ cable box and VCR control features. NOTE: TV GUIDE Plus+ system can only operate the type of VCRs and cable boxes that can select channels using a remote control with a number keypad.



⑥ **active A/V Network terminal**

Use this terminal to connect a Mitsubishi VCR that has an A/V network terminal.

⑦ **video output terminal**

Use this terminal to send the TV video signal to a VCR, A/V receiver or other component.

⑧ **audio output terminals**

Use these terminals to send the TV's audio signal to a VCR, A/V receiver, or other component.

◆ Basic Connections

This section explains the basic connections you will need to make between your TV, antenna and VCR. You will see there are different connections shown depending on the type of antenna you are using, whether or not you have a cable box, or if you will be using TV GUIDE Plus+. Choose the type of connection for the type of equipment you have.

If you have difficulty making any of the connections to your TV, you may want to contact your Mitsubishi dealer or your local cable company.

This section explains the following connections:

- **TV + antenna or cable without a cable box**
- **TV + cable with a cable box**
- **TV + separate UHF and VHF antennas**
- **TV + VCR + antenna or cable without a cable box**
- **TV + VCR + cable with a cable box**
- **TV + stereo audio system**
- **TV + Mitsubishi products that have A/V Network terminals**

► **Warning:** You should unplug your TV and any other components before connecting them.

TV + antenna or cable without a cable box

equipment you will need

If you have a standard 75-ohm coaxial cable, you will not need additional equipment. If your antenna has two leads (called twin lead or 300 ohm antenna lead), you will need:

- One 300-75 ohm matching transformer

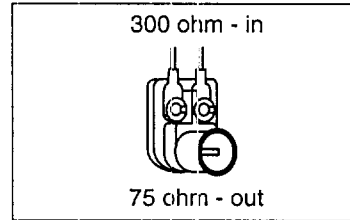

connecting a cable

- Connect the incoming cable or antenna to the ANT-A input terminal on the TV.

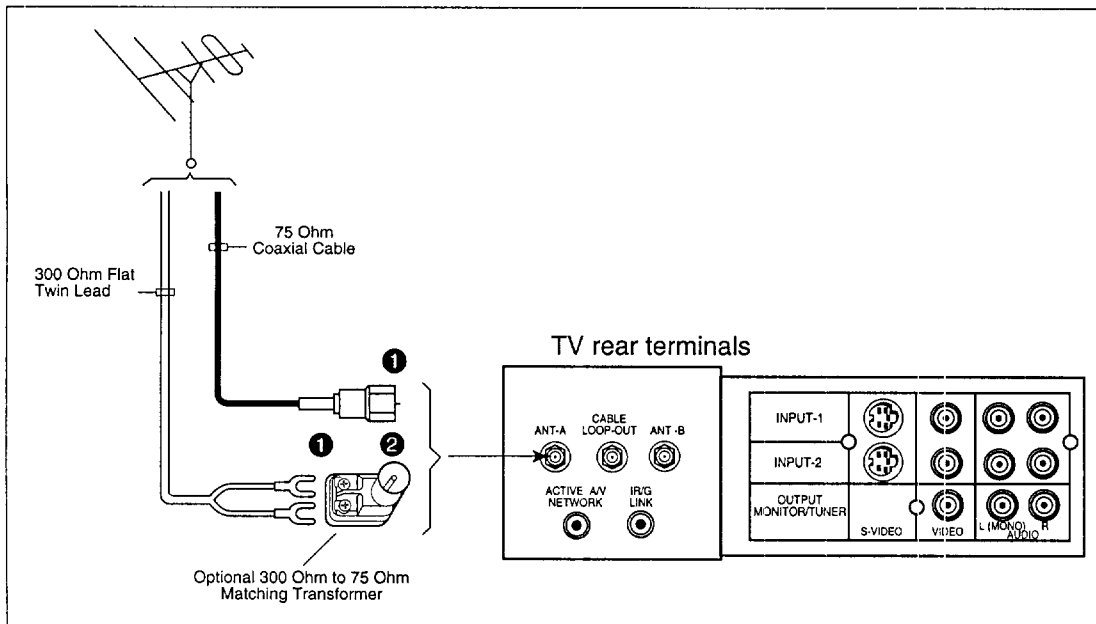

connecting an antenna with twin leads

- 1 Use a screwdriver to connect the 300 ohm twin leads to the transformer.
- 2 Push the 75 ohm side of the transformer onto the ANT-A terminal on the TV.

TV + cable with a cable box



If TV GUIDE Plus+ will be used

Use this hook-up if:

- you will be using TV GUIDE Plus+
- you use a cable box only to descramble premium cable channels

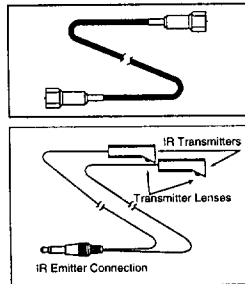

To complete the hook-up, you'll need:

- three lengths of 75 ohm coaxial cable
- one IR emitter (provided with TV)
- one two way splitter (as shown in diagram below.)

- 1 Connect the cable system's incoming cable to the IN terminal on the two-way splitter.
- 2 Connect a coaxial cable to one of the OUT terminals on the splitter; connect the other end of this cable to the ANT-B terminal on the back of the TV.
- 3 Connect a second coaxial cable to the other OUT terminal on the splitter; connect the other end of this cable to the IN terminal on the cable box.
- 4 Connect the third coaxial cable to the OUT terminal on the back of the cable box; connect the other end of this cable to the ANT-A terminal on the back of the TV.
- 5 Connect the IR emitter. Follow the procedures in the *TV GUIDE Plus+ Operating Guide*.

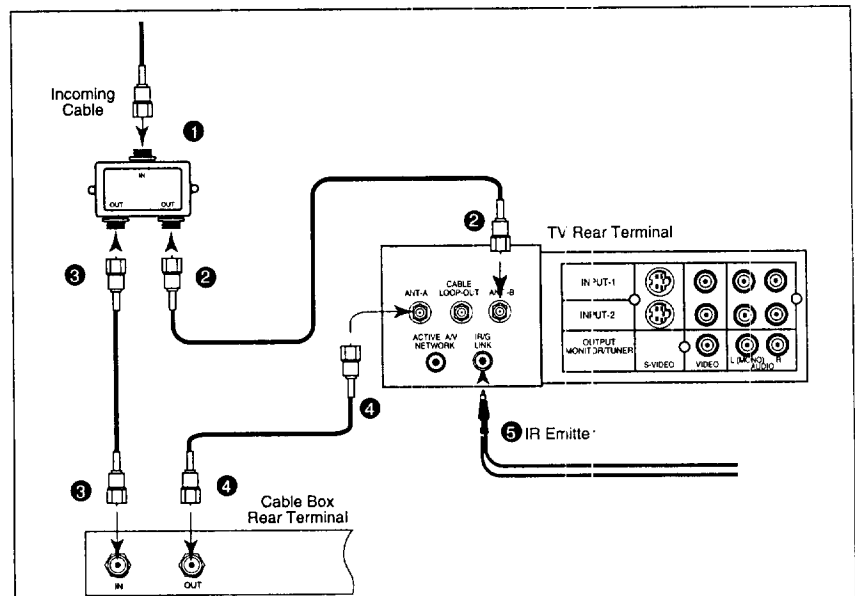

TV + cable with a cable box (cont.)

If TV GUIDE Plus+ will not be used

Use this hook-up if:

- you will not be using TV GUIDE Plus+
- you need a cable box only to descramble premium cable channels

This hook-up will allow you to use the advanced features of your TV, such as 2-tuner PIP and SuperQuickView and watch basic cable channels on Antenna-A. You will be able to view the premium cable channels that are descrambled by your cable box on Antenna-B.

To complete the hook-up, you'll need:

- two lengths of 75 ohm coaxial cable

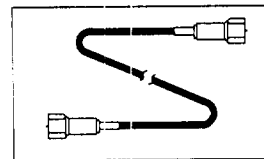

procedure

- 1 Connect the cable system's incoming cable to the ANT-A terminal on the back of the TV.
- 2 Connect a coaxial cable between the CABLE LOOP-OUT terminal on the back of the TV and the IN terminal on the back of the cable box.
- 3 Connect the second coaxial cable between the OUT terminal of the cable box and the ANT-B terminal on the back of the set.

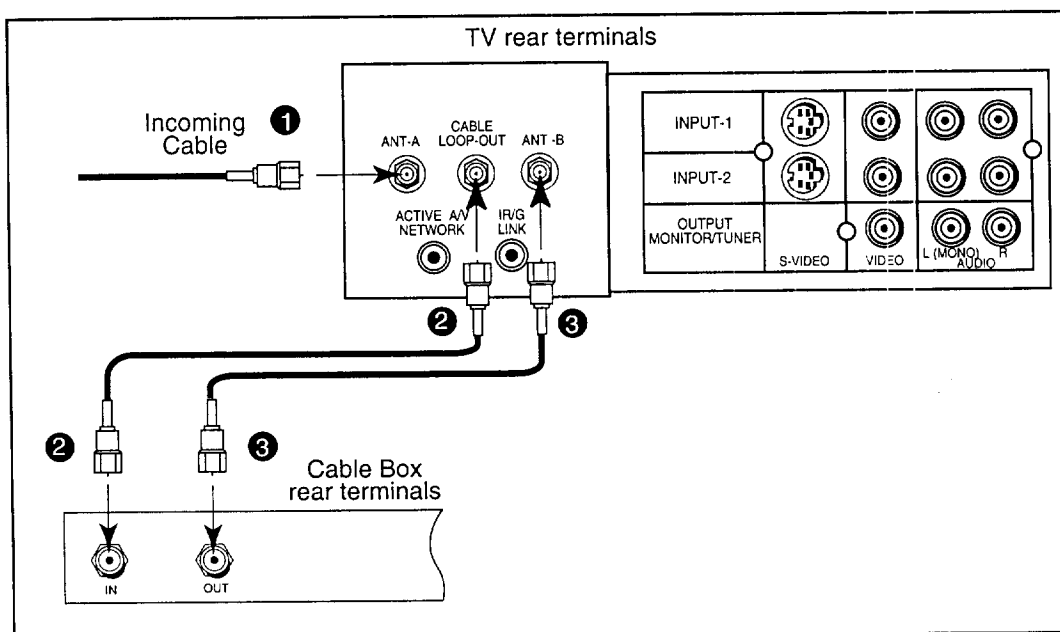

TV + separate UHF and VHF antennas

equipment you will need

If UHF and VHF signals are brought into your home with two separate antennas you'll need to combine them in order to connect them to the TV. To do this you will need a UHF/VHF combiner. (There are different combiners for different kinds of wires. Check with your local electronics store for the kind of combiner you need.)

- Pictured to the right is a standard combiner with the following specifications:

Two (2) 300 ohm inputs
One (1) 75 ohm output

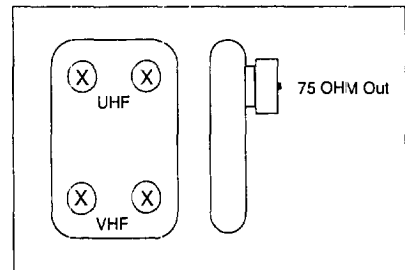

To connect separate UHF and VHF antennas to your TV:

- 1 Connect the UHF and VHF antenna leads to the appropriate terminals on the UHF/VHF combiner.
- 2 Press the combiner onto the ANT-A terminal on the rear of the TV.

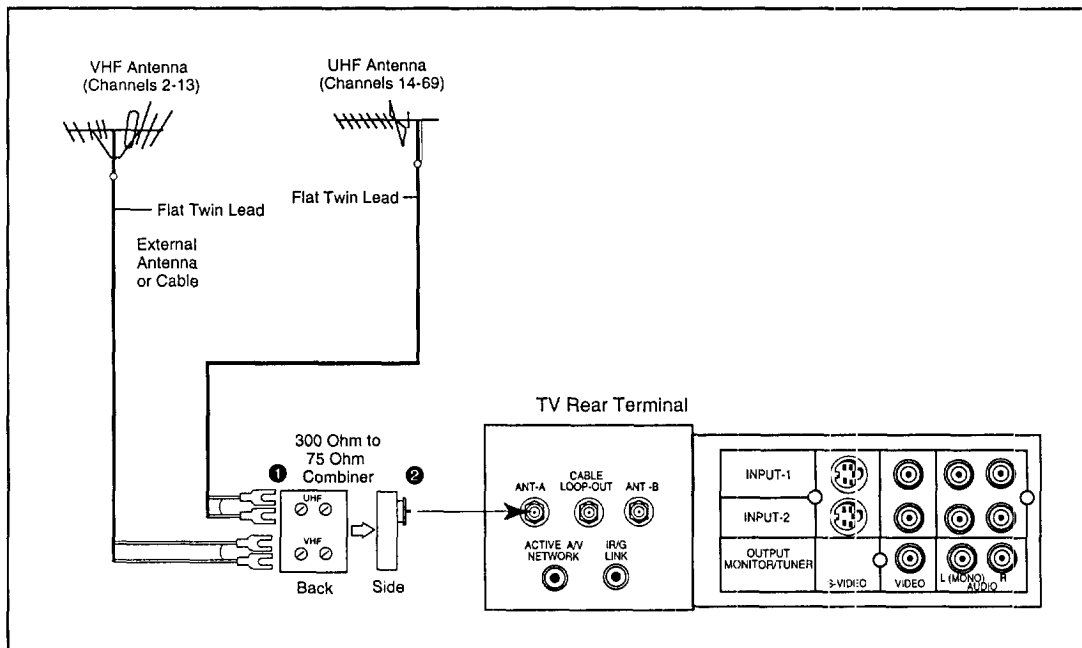

TV + VCR + antenna or cable without a cable box

You may want to connect a VCR along with your antenna or cable. If so, based on whether or not you will be using TV GUIDE Plus+, follow the directions which apply.

To complete the hook-up, you'll need:

- Two lengths of 75 ohm coaxial cable

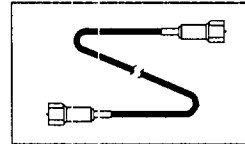

- One set of RCA pin-type audio cables

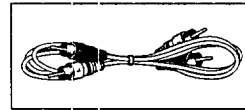

- One RCA pin-type video cable (if connecting a standard VCR)

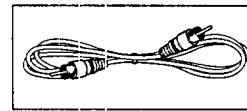

OR

- One S-Video cable (if connecting an S-VHS VCR)

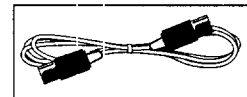

- One IR emitter assembly (if TV GUIDE Plus+ will be used)

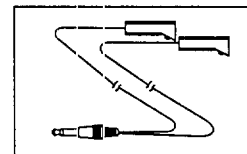

▷ **Important:** If your VCR and/or cable box can only be tuned with a channel up/channel down control, TV GUIDE Plus+ will not function. Only VCRs and cable boxes which can be tuned with a numeric keypad are compatible.

TV + VCR + antenna or cable without a cable box (cont.)

procedure

- ❶ Connect the incoming cable to the ANT-A terminal on back of the TV.
- ❷ Connect one end of a coaxial cable to the CABLE LOOP-OUT terminal on the back of the TV.
- ❸ Connect the other end of the coaxial cable to the ANTENNA IN terminal on the VCR.
- ❹ Connect the second coaxial cable from the VCR ANT-OUT to TV ANT-B.
- ❺ Connect an RCA pin-type video cable to the VIDEO OUT terminal on the back of the VCR. Connect the other end of this cable to one of the VIDEO INPUT terminals on the back of the television.

▷**Important:** If you are connecting a Super VHS (S-VHS) VCR, use an S-Video cable instead of an RCA pin-type video cable. Connect this S-Video cable to the S-VIDEO OUT terminal on the VCR. Connect the other end of this cable to the S-VIDEO INPUT terminal on the back of the TV.

- ❻ Connect a set of RCA pin-type audio cables to the AUDIO OUT terminals on the back of the VCR. Use the red cable to connect the right (R) channel and the white cable for connecting the left (L) channel.
- ❼ Connect the other ends of this cable to the AUDIO INPUT terminals on the back of the TV.



- ❽ If you plan to use TV GUIDE Plus+, connect the IR emitter cable to the IR/G LINK. Place one of the emitter ends in front of the VCR. For more detail concerning the placement of the emitter lenses, see the *TV GUIDE Plus+ Operating Guide*.

▷**Important:** If your VCR is monaural (non-stereo), you only need to connect a single RCA pin-type audio cable. Connect the cable to the audio out terminal of the VCR, then connect the other end to the L (left) audio input on the back of the TV.

▷**Important:** If your VCR has a video channel switch, set it to "OFF/AV". See your VCR owner's guide for details.

**TV + VCR + antenna or cable without a cable box
(cont.)**

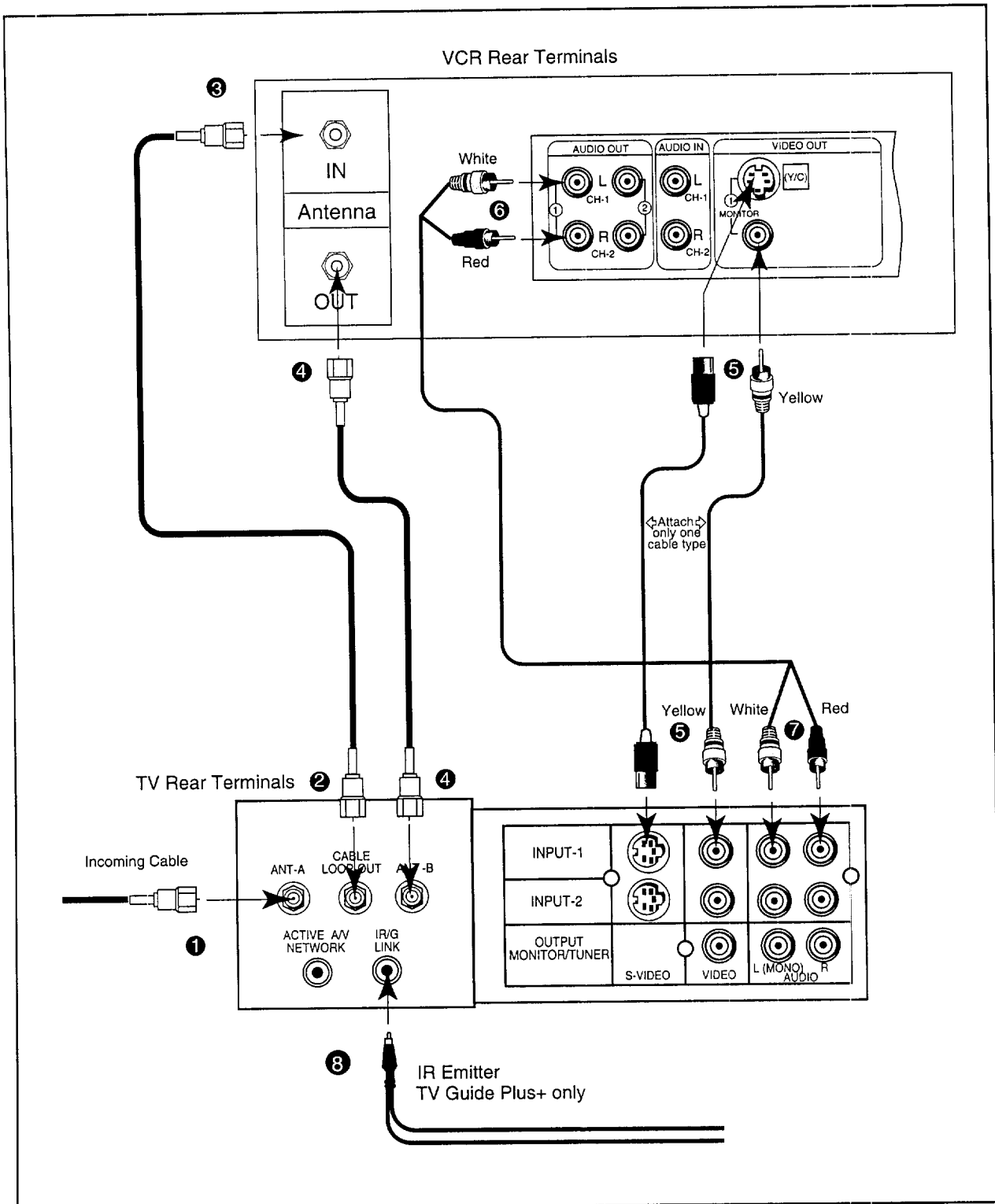

TV + VCR + cable with a cable box



If TV GUIDE Plus+ will be used

Use this hook-up if:

- you will be using TV GUIDE Plus+
- you use a cable box to descramble premium cable channels

To complete the hook-up, you'll need:

- Four lengths of 75 ohm coaxial cable
- One two-way splitter
- One set of RCA pin-type audio cables
- One RCA pin-type video cable (if connecting a standard VCR)

OR

- One S-Video cable (if connecting an S-VHS VCR)
- One IR emitter assembly

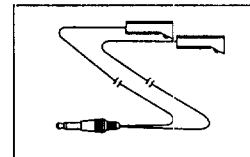
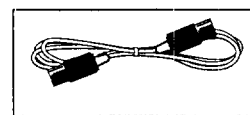
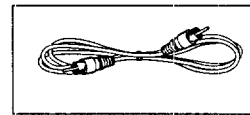
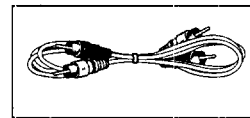
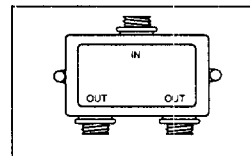
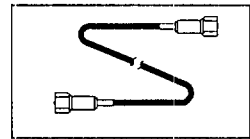

▷ **Important:** If your VCR and/or cable box can only be tuned with a channel up/channel down control, TV GUIDE Plus+ will not function. Only VCRs and cable boxes which can be tuned with a numeric keypad are compatible.

TV + VCR + cable with a cable box (cont.)



procedure

- ❶ Connect the cable system's incoming cable to the IN terminal on the two-way splitter.
- ❷ Connect a coaxial cable to one of the OUT terminals on the splitter; connect the other end of this cable to the ANT-B terminal on the back of the TV.
- ❸ Connect a second cable to the other OUT terminal on the splitter; connect the other end of this cable to the IN terminal on the cable box.
- ❹ Connect the third coaxial cable to the OUT terminal on the back of the cable box; connect the other end of this cable to the ANT-A terminal on the back of the TV.
- ❺ Connect the fourth coaxial cable from the CABLE LOOP-OUT terminal on the back of the TV to the ANTENNA IN terminal on the back of the VCR.
- ❻ Connect an RCA pin-type video cable from the VIDEO OUT terminal on the back of the VCR to the VIDEO INPUT terminal on the back of the TV.

▷ **Important:** If you are connecting a Super VHS (S-VHS) VCR, use an S-Video cable instead of an RCA pin-type video cable. Connect this S-Video cable to the S-VIDEO OUT terminal on the VCR. Connect the other end of this cable to the S-VIDEO INPUT terminal on the back of the TV.

- ❼ Connect a set of RCA pin-type audio cables to the AUDIO OUT terminals on the back of the VCR. Use the red cable to connect the right (R) channel and the white cable to connect the left (L) channel.
- ❽ Connect the other ends of this cable to the AUDIO INPUT terminals on the back of the TV.
- ❾ Connect the IR emitter cable to the IR/G LINK. Place one of the emitter ends in front of the cable box. Place the other emitter end in front of the VCR. For more detail concerning the placement of the emitter lenses, see the *TV GUIDE Plus+ Operating Guide*.

TV + VCR + cable with a cable box (cont.)

- ▷ **Important:** If your VCR is monaural (non-stereo), you only need to connect a single RCA pin-type audio cable. Connect the cable to the audio out terminal of the VCR, then connect the other end to the L (left) audio input on the back of the TV.
- ▷ **Important:** If your VCR has a video channel switch, set it to "OFF/AV". See your VCR owner's guide for details.

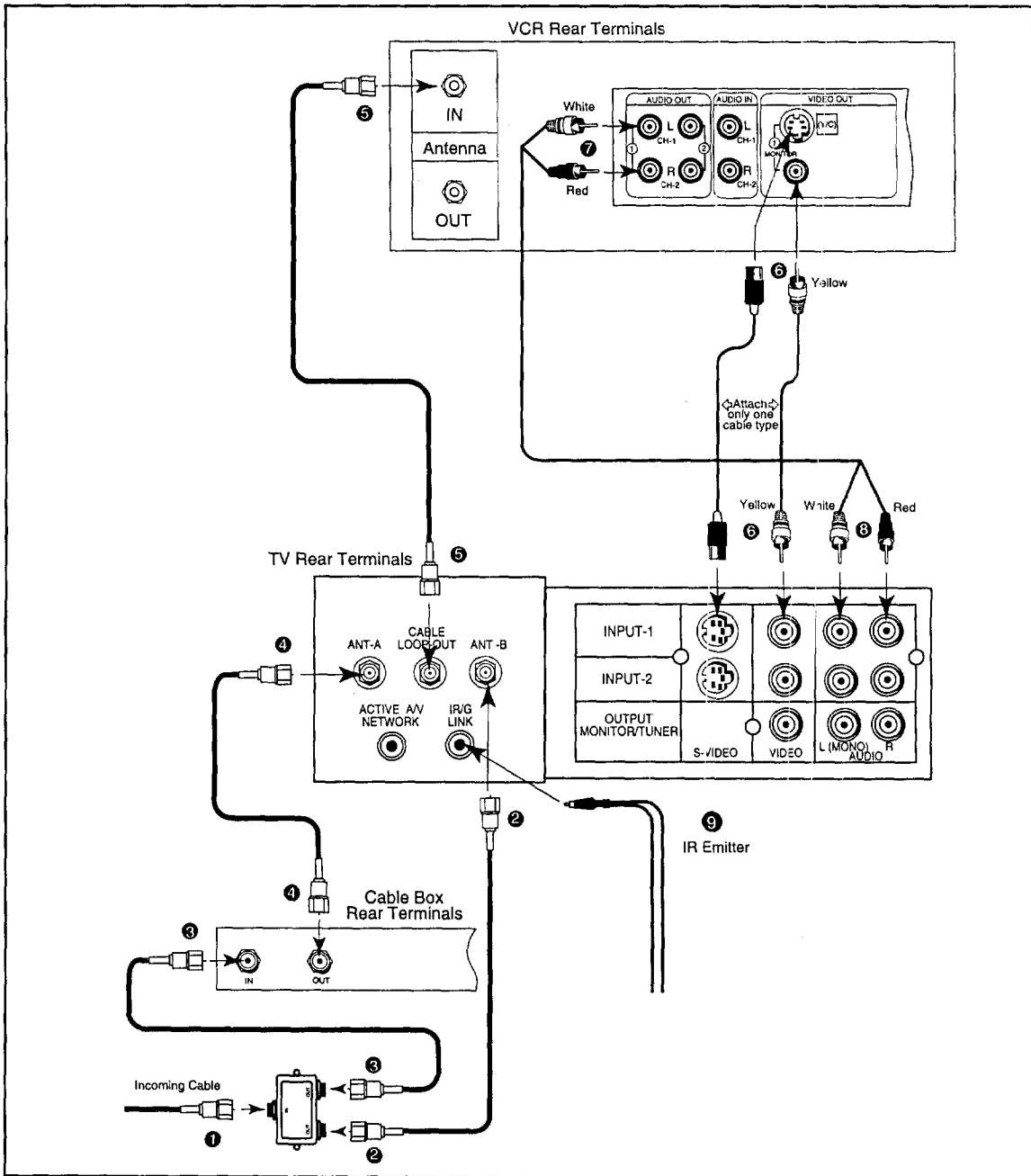

TV + VCR + cable with a cable box (cont.)

If TV GUIDE Plus+ will not be used

Use this hook-up if:

- you will not be using TV GUIDE Plus+
- you use a cable box only to descramble premium cable channels

This hook-up will allow you to use advanced features of your TV, such as 2-tuner PIP and SuperQuickView™ plus watch basic cable channels on Antenna-A. You will be able to view the premium cable channels that are descrambled by your cable box on Antenna-B.

To complete the hook-up, you'll need:

- Three lengths of 75 ohm coaxial cable

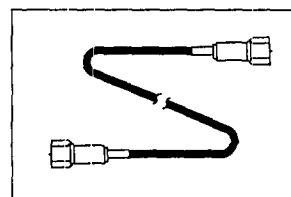

- One set of RCA pin-type audio cables

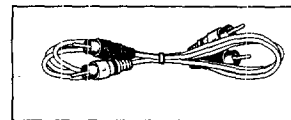

- One RCA pin-type video cable (if connecting a standard VCR)

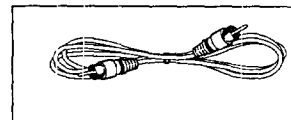

OR

- One S-Video cable (if connecting an S-VHS VCR)

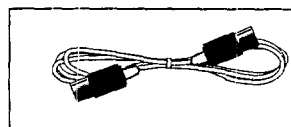

TV + VCR + cable with a cable box (cont.)

procedure

- ❶ Connect the incoming cable to the ANT-A terminal on the back of the TV.
- ❷ Connect a coaxial cable from the CABLE LOOP-OUT terminal on the back of the TV to the cable box IN terminal.
- ❸ Connect a second cable from the OUT terminal on the cable box to the ANTENNA IN terminal on the back of the VCR.
- ❹ Connect a third coaxial cable from the ANTENNA OUT terminal on the back of the VCR to the ANT-B terminal on the back of the TV.
- ❺ Connect an RCA pin-type video cable from the VIDEO OUT terminal on the back of the VCR to the VIDEO INPUT terminal on the back of the TV.

▷ **Important:** If you are connecting a Super VHS (S-VHS) VCR, use an S-Video cable instead of an RCA pin-type video cable. Connect this S-Video cable to the S-VIDEO OUT terminal on the VCR. Connect the other end of this cable to the S-VIDEO INPUT terminal on the back of the TV.

- ❻ Connect a set of RCA pin-type audio cables to the AUDIO OUT terminals on the back of the VCR. Use the red cable to connect the right (R) channel and the white cable to connect the left (L) channel.
- ❼ Connect the other ends of this cable to the AUDIO INPUT terminals on the back of the TV.

▷ **Important:** If your VCR is monaural (non-stereo), you only need to connect a single RCA pin-type audio cable. Connect the cable to the audio out terminal of the VCR, then connect the other end to the left (L) audio input on the back of the TV.

▷ **Important:** If your VCR has a video channel switch, set it to "OFF/AV". See your VCR owner's guide for details.

TV + VCR + cable with a cable box (cont.)

WITHOUT
TV GUIDE PLUS+

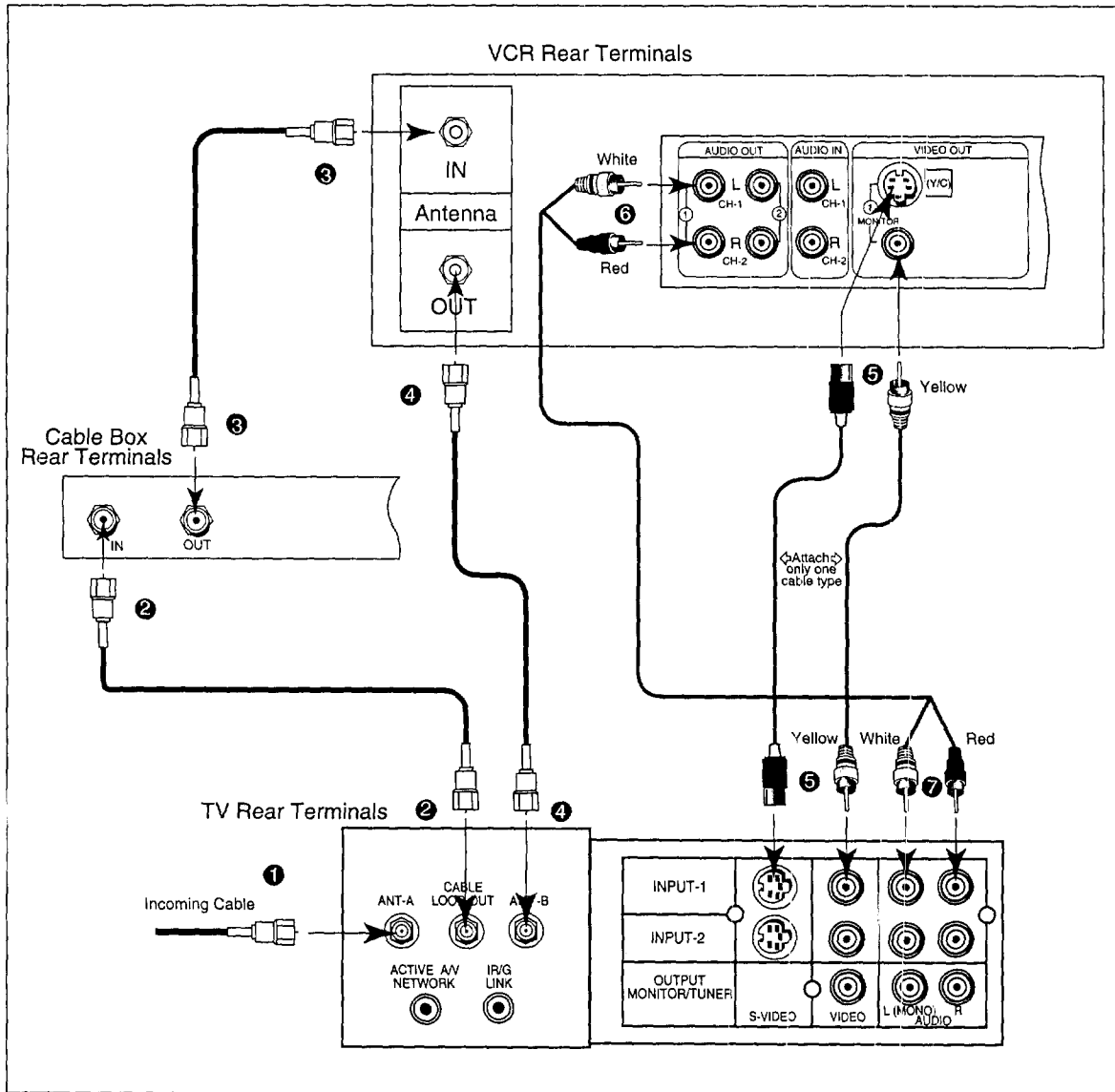

TV + stereo audio system

You may want to hear the sound from your TV and/or VCR through your home audio system. To do this, complete the necessary connections shown on previous pages of this chapter, then follow the procedure on this page.

equipment you will need

To hook up an audio system, you will need one set of RCA pin type audio cables.

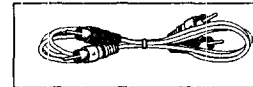

procedure

- 1 Connect the audio cables to the AUDIO OUTPUT terminals on the back of the TV. Use the red cable to connect the right (R) channel and the white cable to connect the left (L) channel.
- 2 Connect the other ends of these cables to the TV IN or AUX IN terminals on the back of the audio system.
- 3 Turn off the TV's speakers. To do this, press AUDIO on the remote control until you see the SPEAKER display. Set the speakers to "Off" by pressing either ADJUST right (▶) or ADJUST left (◀). See "Adjusting the Sound" in Chapter 3.
- 4 Set the audio system's input to the TV or AUX position.

▷ **Important:** For proper tone and volume balance, turn off the TV speakers when using an external audio system.

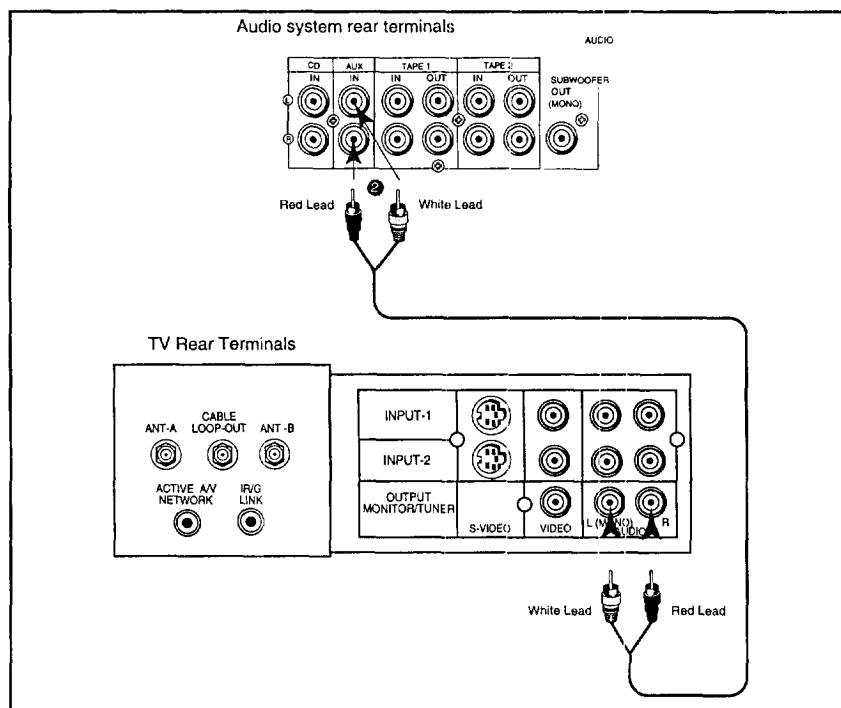

TV + Mitsubishi products that have A/V network terminals

The A/V Network is a special system that Mitsubishi developed to make it easier to use several Mitsubishi products with only one remote control. Only one of the products needs to be in "line of sight" of the remote control. When the supplied cable is connected between two Mitsubishi products with A/V network, you can point the remote control at the TV and it will "pass" the remote control command to the others.

Mitsubishi VCRs that have Active A/V Network can also have the benefits of additional automated tasks. See Chapter 4, *Using the Special Features*, for more information about the Active A/V Network features.

procedure

- 1 Connect one end of the A/V network cable to the ACTIVE A/V NETWORK terminal on the back of the TV.
- 2 Connect the other end of the cable to the A/V NETWORK IN terminal on the back of a Mitsubishi component that has A/V network terminals.

▷ **Important:** Depending on which components you have and the way you plan to use your equipment, the method of connecting the A/V network can change. For more detailed information, review the owner's guide of each particular Mitsubishi component.

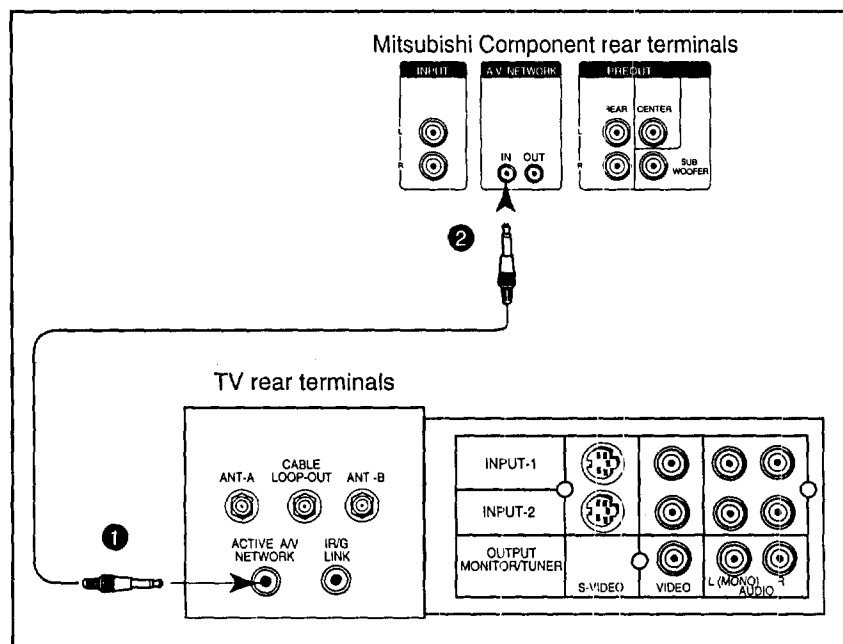



CHAPTER THREE
Operating Your TV

Now that your TV is connected to a cable system and/or an antenna and possibly some external components, it's time to enjoy your equipment. This chapter will explain how to operate the TV, first focusing on functions that are basic and easy and then explaining some advanced features.

This chapter explains:

- ◆ **Getting Started**
- ◆ **Using the Advanced Features**

◆ Getting Started

This section is designed to get you started enjoying your new TV. If you follow these procedures one by one, you will soon begin discovering everything your television can do.

You'll find information on:

- **Using the remote control to operate VCRs, cable boxes, and other equipment**
- **Turning the TV on/off**
- **Selecting the input source to watch your VCR or other equipment**
- **Changing channels**
- **Understanding the ViewPoint® on-screen menus**
- **Setting the clock**
- **Memorizing channels**
- **Adding and deleting channels**
- **Setting the A/V network**
- **Adjusting the convergence**
- **Selecting the menu type**
- **Naming the input**
- **Naming the channels**
- **Using video mute**
- **Selecting the menu language**
- **Selecting the A/V memory categories**
- **Customizing the A/V memory settings**

Using the remote control to operate VCRs, cable boxes and other components

about your remote control

This TV's remote control has four "layers": the TV layer, the VCR-A layer, the DVD layer, and the AUDIO layer. Each layer can be used to operate a different component in your A/V system. You choose the layer you want to use by setting the "select" switch across the top of the remote control.

When you first receive your remote control, the TV layer is set up to operate your Mitsubishi TV and VCR-A is set up to operate your Mitsubishi VCR. The DVD layer is programmed to operate your Mitsubishi DVD player and the AUDIO layer is programmed for your Mitsubishi A/V receiver.

You can use the following to operate your TV:

- power button
- pause button
- mute control
- SuperQuickView™ button
- QuickView™ button
- volume control
- input button
- channel control
- enter button
- TV Guide+ button
- audio and video controls
- menu button
- cancel button
- information button
- home button
- sleep timer button
- number buttons
- PIP controls
- play button
- AV memory button
- arrow buttons



► **Important:** The TV GUIDE Plus+ button is functional only after you activate it as described in the *TV GUIDE Plus+ Operating Guide*.

If you have a cable box (including some digital satellite boxes), a non-Mitsubishi VCR, or if you have a Mitsubishi laserdisc player, A/V receiver, or compact disc player, you can set up the layers in the remote control to operate these components.

The VCR-A layer can be set up to operate a non-Mitsubishi VCR. The DVD layer can be set to operate a VCR, cable box, digital satellite box, or a Mitsubishi laserdisc player. The AUDIO layer can be set up to operate a cable box, digital satellite box, laserdisc player, or an A/V receiver. The TV layer can be set up to operate the volume control of a Mitsubishi A/V receiver.

Using the remote control to operate VCRs, cable boxes and other components (cont.)

setting up the remote control to operate your VCR

- 1 Turn off your VCR.
- 2 Set the select switch on the remote to choose the layer you want to set up: VCR-A or DVD.
- 3 While holding in the POWER button on the remote control, enter the code number listed in the chart below for your brand of VCR. Be sure to enter both digits of the code number. If more than one number is listed, begin with the first one.
- 4 Release the POWER button.

If your VCR is this brand...	...enter this code	If your VCR is this brand...	...enter this code	If your VCR is this brand...	...enter this code
Mitsubishi (A)	01	Magnavox	03, 10, 11	Scot	15
Mitsubishi (B)	02	Multitech	06	Sharp	16
Canon	03	NEC	12	Sony	17, 18
Emerson	04, 05	Panasonic	03	Sylvania	03, 10, 11
Funai	06	Philco	03, 10	Symphonic	06
General Electric	03	Philips	03, 10, 11	Teknika	04, 06
Goldstar	07	Quasar	03	Toshiba	15
Hitachi	08	RCA	08, 13, 20	Totevision	07
JVC	09	Sanyo	14	Zenith	19

- 5 Press the POWER button again. Your VCR should turn on. If the VCR turns on, your remote control is ready to operate your VCR. If your VCR does not turn on, repeat the instructions trying each code number from 01 to 21.

using remote control to operate your VCR

After you have set up your remote control for your particular brand of VCR, you can use the remote to operate your VCR.

- 1 Set the select switch on the remote control to the layer that you set up to operate your VCR: VCR-A or DVD.
- 2 Point the remote control at the VCR and press the desired buttons.

If you are using a Mitsubishi VCR, you will be able to use all of the buttons on the remote control to operate your VCR except for MUTE, VOLUME and the PIP function buttons, which will always operate the TV itself.

If you are using another brand of VCR, you can use the POWER, CHANNEL, REC, STOP, Pause, REW, PLAY, and FF buttons to operate your VCR.

Using the remote control to operate VCRs, cable boxes and other components (cont.)

setting up the remote control to operate your cable box or digital satellite box

- ❶ Turn on your cable box or digital satellite box.
- ❷ Set the select switch on the top of the remote to choose the layer you want to set up: AUDIO or DVD.
- ❸ While holding in the POWER button on the remote control, enter the code number listed in the chart below for your brand of cable or satellite box. Be sure to enter both digits of the code number. If more than one code is listed, begin with the first one.
- ❹ Release the POWER button.

If your cable/satellite box is this brand...	...enter this code	If your cable/satellite box is this brand...	...enter this code	If your cable/satellite box is this brand...	...enter this code
ABC	57, 59, 62, 67, 89	Oak	61, 62, 82	Scientific Atlantic	66, 88, 89, 91, 92
Color Voice	73, 74, 98	Panasonic	63, 70	Signature	57
Comtronics	93	Paragon	51	Sony DSS	47
Gemini	55	Philips	73, 74, 75, 76, 77 93, 94, 98, 99	Sprucar	63
General Electric	66			Starcom	54, 55, 56, 87
General Instruments	55, 56, 57	Pioneer	64, 65, 84	Stargate	55
Hamlin	52, 53, 69	Prime Star	48	Tocom	67, 68, 72
Hitachi	57	Pulsar	51	Toshiba	51
Jerrold	54, 55, 56, 57, 58 59, 60, 85, 87	RCA	63	United Artists	62
		RCA DSS	49	United Cable	54
Macom	71	Regal	53	Viewstar	93, 94
Magnavox	94	Regency	79	Zenith	51
Memorex	51	Samsung	65, 84		

- ❺ Press the POWER button again. Your cable or satellite box should turn off. If it does, your remote control is now set up to operate it. If your cable or satellite box does not turn off, repeat the instructions above, trying each code number listed for your brand of cable or satellite box. If none of these numbers work, try each code number from 47-99.

▷ **Important:** After setting up your remote control, if you cannot turn on the cable box by pressing POWER, try using the CHANNEL button or number buttons. Some cable boxes will turn on when a channel is requested.



If you are using TV GUIDE Plus+, do not turn the cable box off. Always leave the cable box on.

Using the remote control to operate VCRs, cable boxes and other components (cont.)

using your remote control to operate your cable or satellite box

After you have set up your remote control for your particular brand of cable or satellite box, you can use the remote to operate it.

- 1 Use the select switch on the remote control to choose the layer that you set up to operate your cable/satellite box: AUDIO or DVD.
- 2 Point the remote control at the cable/satellite box and press the desired buttons.

You can use the POWER, CHANNEL, numbers (0-9), and ENTER buttons to operate your cable box. If you are using an RCA DSS or PRIMESTAR® receiver, you may be able to use additional buttons. Refer to the instructions for these devices.

PRIMESTAR® is a registered servicemark of PRIMESTAR Partners LP.

setting up the remote control to operate your Mitsubishi disc player or A/V receiver

- 1 Turn off your audio component.
- 2 Set the select switch on the top of the remote to choose the layer you want to set up. For a laser disc player, choose AUDIO or DVD. For an A/V receiver, choose TV or AUDIO.
- 3 While holding in the POWER button on the remote control, enter one of these code numbers:
 - For a Mitsubishi A/V receiver and compact disc player: 30, 31, 35 or 38
 - For a Mitsubishi and some Pioneer Laserdisc players: 32 or 33
 - For a Yamaha A/V receiver and compact disc player: 36 or 37
 - For a Mitsubishi DVD player: 34

Be sure to enter both digits of the code number. If more than one number is listed, begin with the first one.

- 4 Release the POWER button.
- 5 Press the POWER button again. Your disc player or audio component should turn on. If it does, your remote control is now set up to operate your audio component. If it does not turn on, repeat the instructions above, trying the other code number listed for your component.

See “Using Your Remote Control to Operate Your Mitsubishi Laserdisc Player” and “Using Your Remote Control to Operate Your Mitsubishi A/V Receiver” on the next page for information on using the remote to operate your A/V components.

Using the remote control to operate VCRs, cable boxes and other components (cont.)

notes about your remote control

- ▷ **Important:** Sometimes manufacturers will change their products, or they may use more than one code. If this is the case, your remote may not be able to operate your VCR or cable box.
- ▷ **Important:** When you replace the batteries in your remote control, the remote will usually return to its initial setting. You may need to set up your remote again.

using your remote control to operate your Mitsubishi laserdisc player or DVD player

After you have set up your remote control for your laserdisc player or DVD player, you can use the remote to operate it.

- ❶ Use the select switch on the remote control to choose the layer that you set up to operate your laserdisc player, AUDIO or DVD.
- ❷ Point the remote control at the laserdisc player and press the desired buttons.

You can use the POWER, CHANNEL, numbers (0–9), INFO, MENU, CANCEL, STOP, PAUSE, REW, PLAY, cursor (◀▶), and FF buttons to operate your disc player.

using your remote control to operate your Mitsubishi A/V receiver

After you have set up your remote control for your A/V receiver, you can use the remote to operate it.

- ❶ Use the select switch on the remote control to choose the layer that you set up to operate your receiver: TV or AUDIO.
- ▷ **Important:** It is recommended that you set up your A/V receiver in the AUDIO layer as well as the TV layer. If you set up your remote control for your A/V receiver in the TV layer, you will only be able to control the VOLUME and MUTE functions.
- ❷ Point the remote control at the A/V receiver and press the desired buttons.

Using the remote control to operate VCRs, cable boxes and other components (cont.)

If you are using a Mitsubishi HTS-100 surround sound amplifier, enter code 30 to use the POWER, VOLUME, and MUTE buttons.

If you are using a Mitsubishi HTS-300 receiver, enter code 31 to use the POWER, CHANNEL, INPUT, VOLUME, ENTER, number (0–9), INFO, MENU, CANCEL, AUDIO, VIDEO, ADJUST, and MUTE buttons.

If you are using a Mitsubishi M-VR400 (code 35), M-VR600 (code 35), M-VR800 (code 38), or M-VR1000 (code 38), you can use the POWER, VOLUME, number (0-9), and MUTE buttons to operate the receiver. The ADJUST buttons will access the M-VR800 and M-VR1000 menus.

If you are using a Mitsubishi M-CD500 CD changer, you can use the PLAY, PAUSE, STOP, FF, and REW buttons to operate the changer.

Resetting the layer of your remote to the original factory setting

- ➊ Set the select switch on the remote to choose the layer you have set the component to.
- ➋ While holding in the POWER button on the remote control, enter the code 00.
- ➌ Release the POWER button.

Turning the TV on/off

- ▷ **Important:** Before using the remote control to operate the TV, set the select switch on the top of the remote control to TV.

Use the POWER button on either the control panel or the remote control to turn the TV on and off. The power/program timer indicator on your TV will light up in green when you turn the TV on.

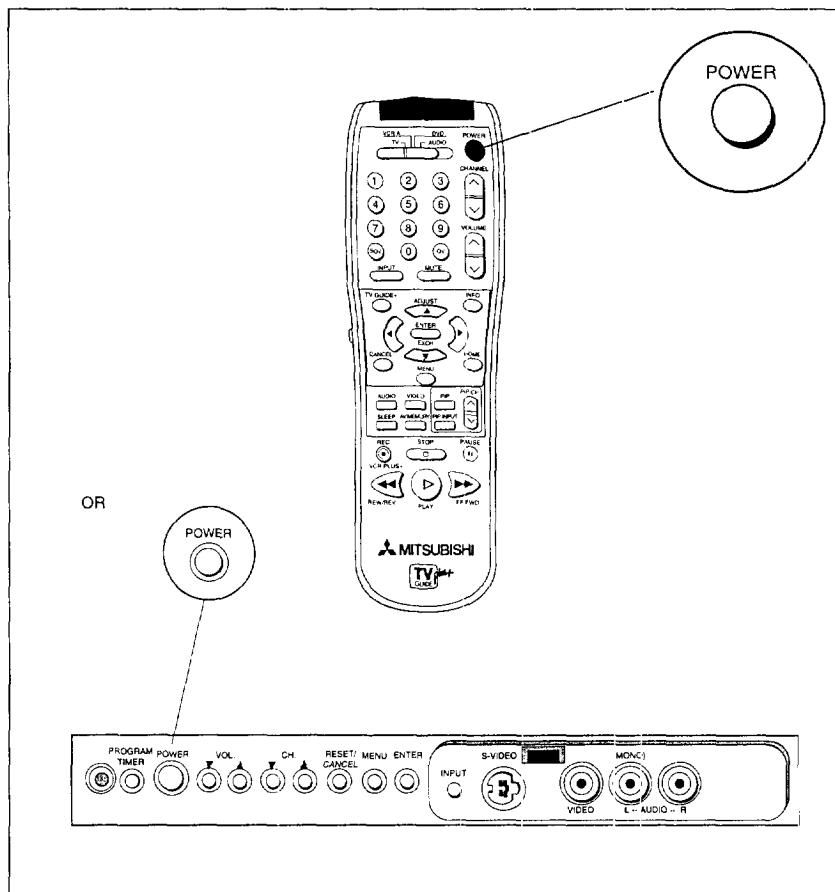

- ▷ **Important:** There is always a small amount of current flowing into the TV, even when the power is turned off. This maintains any changes to the TV's settings and operates the built-in clock and timing functions. Unplugging the set will erase these settings, requiring you to set them again. Unplug the TV only when it won't be used for a long time.

Selecting the input source to watch your VCR or other equipment

If you connected components such as VCRs, camcorders, or laser-disc players to your TV, you will need to change the input source to view the signals from these components.

To select an input source, press the input button (INPUT) on the control panel or on the remote control.

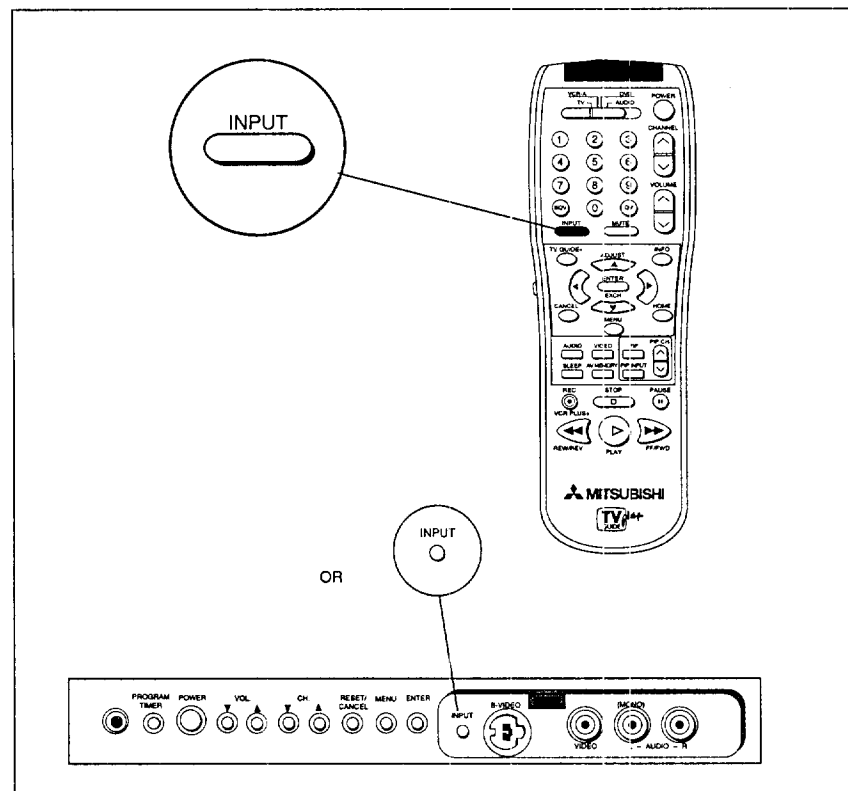

You can choose between the following input sources:

- ANT-A or ANT-B -- (antennas or cable systems connected to the antenna terminals)
- Input 1 or Input 2 -- (components connected to the terminals on the back of your TV)
- Input 3 -- (a component connected to the terminals on the front panel of your TV)

When selected, the name of the input you have selected will display briefly in the upper right corner of the screen.

Changing channels

Your TV offers you six ways of changing channels once their numbers have been programmed into channel memory:

- selecting channels one-by-one with the CHANNEL up (▲) and CHANNEL down (▼) controls
- directly accessing a channel by pressing the number buttons
- using the QuickView™ option to recall the last channel
- using the special QuickView™ option to switch to a particular memorized channel
- using the SuperQuickView™ function to alternate between channels on a user-chosen list



- using the ADJUST (▲ ▼) buttons with TV GUIDE Plus+ surf screen

- ▷ **Important:** To change channels faster, use either of the following procedures:
- Enter three digits for every channel number, using zeros where needed. For example, enter 004 to view channel 4 and 028 to view channel 28, or
 - Press the ENTER button after selecting the number of the channel. For example, press 4, then press ENTER (in less than three seconds) to view channel 4.
- ▷ **Important:** If only one or two keys are used to select the channel number, the onscreen display will appear and remain visible for three seconds if no more keys are entered. Once the display is no longer visible, the TV will tune to the selected channel.
- ▷ **Important:** If you memorized channels using the Indoor/Outdoor Antenna option, your TV can receive antenna channels 2-13 (VHF) and 14-69 (UHF). If you memorized channels using the Cable option, your TV can receive cable channels 1-125. If you select a channel outside of these ranges, your TV will not change channels.

Changing channels (cont.)

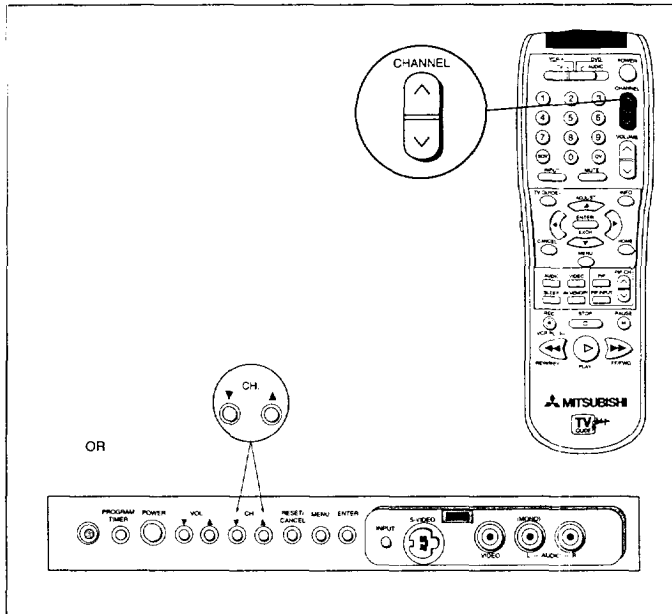

changing channels one-by-one

To change channels:

- Press one of the channel buttons (CHANNEL) on the control panel or on the remote control. The TV will automatically tune to the next memorized channel.

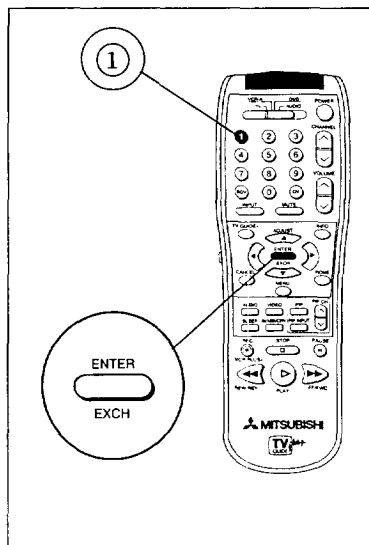

changing channels directly

To move directly to a particular channel without going through the programmed channels in-between:

- 1 Use the number buttons on the remote control to select the number of the channel you want to view.
- 2 Press the ENTER/EXCH button.

Changing channels (cont.)

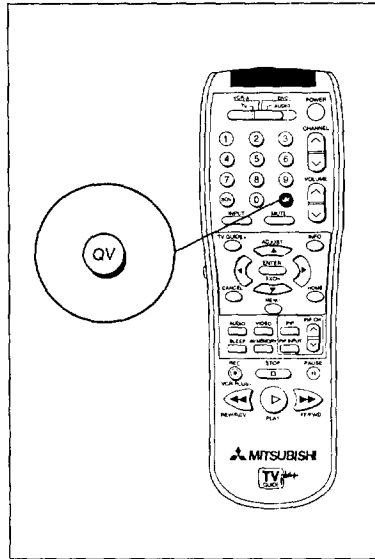

using the QuickView™ option

The **QuickView** feature can work in two ways: to recall the last channel viewed (**Last Channel Recall**), or to recall a channel you put into QuickView memory.

- If you have not memorized any channels into QuickView Memory, **Last Channel Recall** allows you to use the QV button to switch back and forth between the current channel and the last one viewed.
- **QuickView Memory** allows you to use the QV button to switch back and forth between the last channel you were watching and the channel you put into QuickView memory.

Setting the QuickView memory

- ➊ Tune to the channel you wish to memorize.
- ➋ Press and hold the QV button for about 2 seconds. The channel numbers and a QV indicator will appear on the screen, indicating that you have memorized that channel.
- ➌ After changing to another channel, press the QV button to immediately return to the memorized channel.
- ➍ If you press the QV button while watching the memorized channel, you will return to the last channel viewed.

▷ **Important:** The memorized QV channel will remain in memory until you replace it with a new channel using the procedure above. Once a channel has been programmed as a QV channel, you cannot use the QV button to switch between the current and the last viewed channel **unless** you re-select the current channel as the QuickView channel.

Changing channels (cont.)

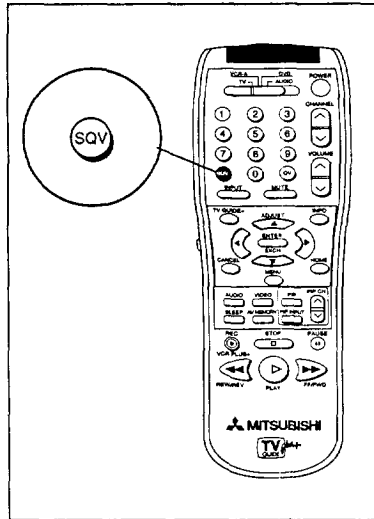

using the SuperQuickView™ option

To view selected channels programmed into SuperQuickView memory:

- 1 Enter the desired channel into SuperQuickView memory. For additional information, see “Using SuperQuickView” in this chapter.
- 2 Press the SQV button repeatedly to view the SQV channels in sequence.

Understanding the ViewPoint® on-screen menus

One of the distinctive features of this TV is Mitsubishi's exclusive

▶ ViewPoint®

ON-SCREEN OPERATING SYSTEM

Unlike other television menu systems, ViewPoint includes a special Picture-in-Picture screen to let you view the TV picture while you are using the menu.

ViewPoint also provides step-by-step instructions for using some of the TV's special capabilities.

When using the ViewPoint system, please keep the following in mind:

- The selected menu item is indicated in yellow.
- The on-screen menus will turn off if no item is selected within 5 minutes.
- Some on-screen menu items must be set before other items are available. For example, "Set the Timer" will only be available if "Set the Clock" has been set.
- You can exit the on-screen menus any time by pressing the MENU button repeatedly. You will then return to regular TV viewing.
- You can also exit the on-screen menus by pressing the HOME button on the remote control. You only need to press the HOME button once to completely exit from all menus.

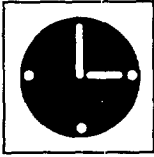

Setting the clock



TV GUIDE Plus+ users may skip this section. TV GUIDE Plus+ will automatically set the clock. See the *TV GUIDE Plus+ Operating Guide*.

Your TV contains an internal clock. If there is a broadcaster in your area that is sending the current time along with its regular broadcast signal, then your TV can automatically set its clock with this signal. Otherwise, you can set the clock yourself.

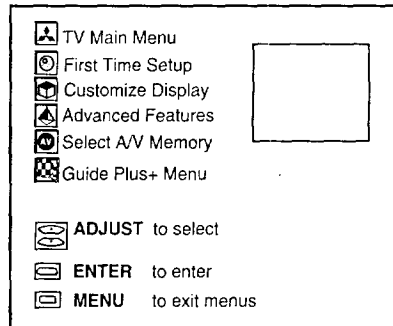

1 Press the MENU button on the remote control. The Main Menu will appear on the screen.

2 Use the ADJUST buttons to select "First Time Setup." Press ENTER/EXCH.

3 You will see the "First Time Setup" screen. Use the ADJUST buttons to select "Set the Clock." Press ENTER/EXCH.

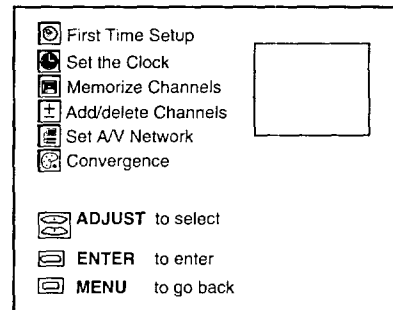

4 If you want your TV to set the clock automatically, use the ADJUST buttons to set "Auto clock" to "On". Press ENTER/EXCH.

5 If you want to set the clock yourself, set "Auto clock" to "Off" and follow the steps outlined in *Setting the Clock Yourself* later in this chapter.

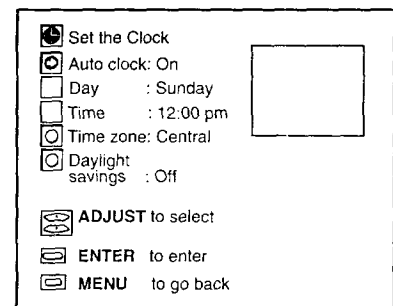

using automatic clock setting

1 Use the ADJUST buttons to select the time zone you live in. The available time zones are: Central, Mountain, Pacific, Alaska, Hawaii, Atlantic and Eastern.

2 Press ENTER/EXCH.

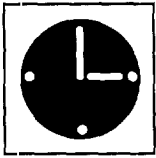

Setting the clock (cont.)



TV GUIDE Plus+ users may skip this section. TV GUIDE Plus+ will automatically set the clock. See the *TV GUIDE Plus+ Operating Guide*.

<input checked="" type="checkbox"/>	Set the Clock	
<input type="checkbox"/>	Auto clock: On	
<input type="checkbox"/>	Day : Sunday	
<input type="checkbox"/>	Time : 12:00 pm	
<input type="checkbox"/>	Time zone: Central	
<input checked="" type="checkbox"/>	Daylight savings : Off	
	ADJUST to select	
	ENTER to enter	
	MENU to go back	

- If you follow daylight savings time, use the ADJUST buttons to select "On." Otherwise, select "Off." Press ENTER/EXCH.
- The automatic clock set up is completed. The screen will return to the "First Time Setup" menu.

- ▷ **Important:** The TV's clock will not be set until you tune your TV to a channel that broadcasts the time via Extended Data Services (XDS). If your TV loses power, you will need to tune to that channel again to reset your clock. Most PBS stations broadcast the time setting signal.
- ▷ **Important:** If you set "Daylight savings" to "On", your TV will adjust the clock by one hour when daylight savings time begins and ends. This automatic feature only works when your TV has selected a channel that sends the XDS time setting signal.
- ▷ **Important:** If you are receiving a VCR signal on channel 3 or channel 4, the automatic setting may not work correctly. Turn your VCR off if it is not being used.

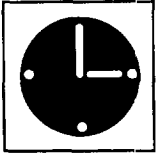

Setting the clock (cont.)



TV GUIDE Plus+ users may skip this section. TV GUIDE Plus+ will automatically set the clock. See the *TV GUIDE Plus+ Operating Guide*.

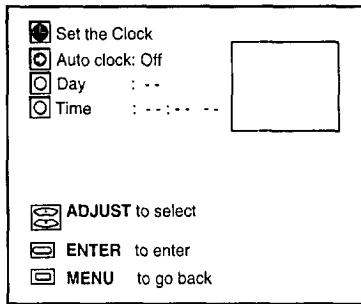

setting the clock yourself

1 Use the ADJUST buttons to set "Auto clock" to "Off". Press ENTER/EXCH.

2 Use the ADJUST buttons to select the "Day". Press ENTER/EXCH.

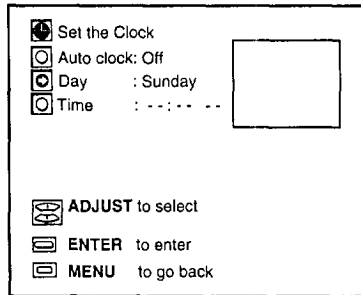

3 Use the ADJUST buttons or number buttons to set the "Time".

4 After you have set the "Day" and "Time", press the ENTER/EXCH button to start the clock. The screen will return to the "First Time Setup" menu.

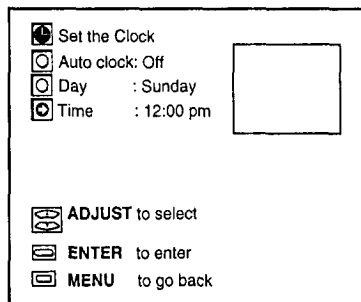

►Important:

You can clear the time by pressing the CANCEL button when "Auto clock" is highlighted.

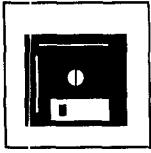

Memorizing channels



TV GUIDE Plus+ users do not need to memorize channels for ANT-A. TV GUIDE Plus+ will do this automatically. See the *TV GUIDE Plus+ Operating Guide*. However, you should still memorize channels for ANT-B if that input will be used. If you will not be memorizing channels for ANT-B, proceed to “Setting the A/V Network.”

You can use the menus to automatically memorize the channels your TV can receive and skip the unused channels. Once channels are memorized, you can scan through them using the channel up/down controls on the remote control and control panel.

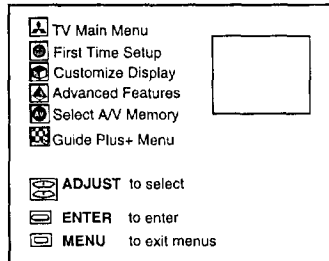

1 Press the MENU button. The Main Menu will appear on the screen.

2 Use the ADJUST buttons to select “First Time Setup”. Press ENTER/EXCH.

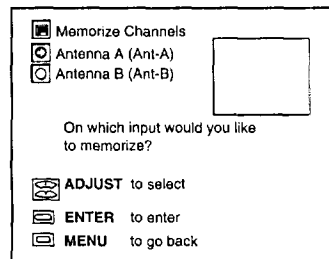

3 At the “First Time Setup” screen, use ADJUST buttons to select “Memorize Channels”. Press ENTER/EXCH.

4 Use the ADJUST buttons to select the terminal (ANT-A or ANT-B) to which the antenna or cable system is attached. Press ENTER/EXCH. (If using both terminals, memorize channels for one of the terminals now).

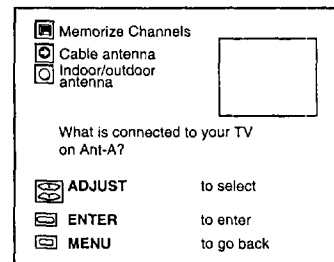

5 Use the ADJUST buttons to choose the type of antenna you connected: Cable antenna or Indoor/outdoor antenna. Press ENTER/EXCH.

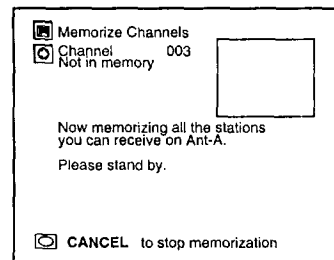

6 You will see a message that channel memorization is in progress. A channel being added to memory will be labeled “In memory”. Channels not being added will be labeled “Not in memory”. You can stop channel memorization at any time by pressing CANCEL.

► **Important:** CHANNEL up/down controls will work differently after channels have been memorized. After memorizing, use the channel controls (CHANNEL) to advance sequentially to the next memorized channel. Use the number buttons to select individual channels.



Adding and deleting channels



TV GUIDE Plus+ offers a singular method to add/delete channels. See the *TV GUIDE Plus+ Operating Guide*. However, you can still follow the instructions below for ANT-B channels.

After all available channels have been memorized with the “Memorize Channels” feature, channels with weaker signals can be added or deleted with the following procedure.

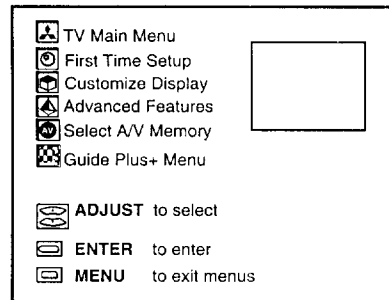

1 Press the MENU button on the remote control. The Main Menu will appear on the screen.

2 Use the ADJUST buttons to select “First Time Setup”. Press ENTER/EXCH.

3 Use the ADJUST buttons to select “Add/delete Channels”. Press ENTER/EXCH.

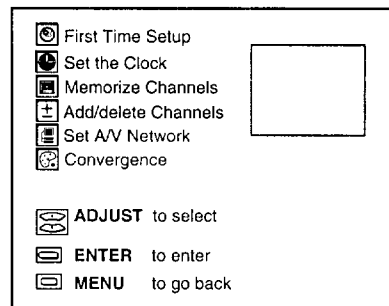

4 The “Add/delete Channels” screen will appear. Use the ADJUST buttons to select the channel you would like to add or delete.

(You can also use the CHANNEL controls to select channels already in memory.)

Either “In memory” or “Not in memory” will appear.

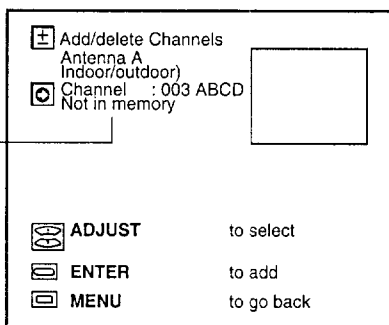

5 If a channel is labeled “In memory”, use the CANCEL button to remove it from memory. If a channel is labeled “Not in memory”, use the ENTER/EXCH button to add it to memory.

6 When you are finished adding and deleting channels, press the HOME button to return to normal TV viewing.

Adding a channel to memory allows you to tune to the channel with the CHANNEL up/down controls. If a channel is not in memory, you can only tune to it with the number buttons.



Setting the A/V Network

The A/V Network is a system that Mitsubishi developed to make it easier to operate many products with one remote control. When the A/V Network is connected between two Mitsubishi products, you can point the remote control at one product and it will “pass” the remote control command to the other. In addition, Active A/V Network will automate the TV’s input selection and the playback of Mitsubishi VCRs into a single command. To set up the A/V Network:

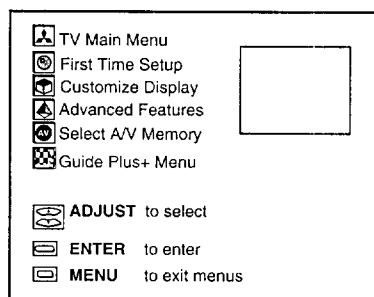

❶ Press the MENU button. The Main Menu will appear on the screen.

❷ Use the ADJUST buttons to select “First Time Setup.” Press ENTER/EXCH.

❸ Use ADJUST to select “Set A/V Network,” then press ENTER/EXCH.

❹ Use the ADJUST buttons to select “Active,” “Basic,” or “Off.” Check the rear terminals of your VCR, then use the chart below to determine how you should set your TV.

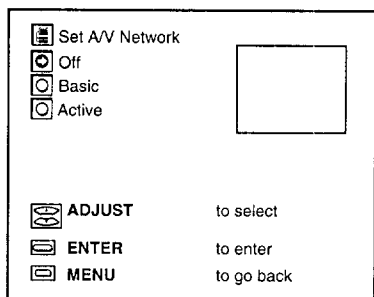

If your VCR has a rear terminal that reads:	...and you have set your VCR to:	...then set your TV to:
A/V Network	--	Basic
Active A/V Network	Off	Basic
Active A/V Network	Active	Active
Does not have an A/V Network rear terminal	-	Off

❺ Press the ENTER/EXCH or MENU button to return to the “First Time Setup” menu. Press HOME to exit all menus. If you are not sure how to set your VCR’s A/V Network setting, refer to your VCR’s owner’s guide.

▷ **Important:** The A/V Network can still be used to pass remote control signals even when the TV’s “A/V Network” setting is “Off”.

▷ **Important:** If you do not use the A/V Network system, set “A/V Network” to “Off”. If you don’t, channel selection may not work correctly.

▷ **Important:** If you select Active or Basic A/V settings, make sure your Mitsubishi VCR with an A/V Network or Active A/V Network connection is connected to Input-1 and the A/V network cable is in place.

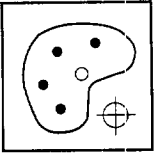

Adjusting the convergence

Your Mitsubishi Projection TV has three picture tubes and large diameter lenses which are aligned to project light beams on the screen. Each picture tube projects only one color: red, green or blue.

This special feature allows you to finely tune the convergence at 5 positions if you think that the red and/or blue light beams are out of alignment. The green beam acts as a fixed reference for aligning the red and blue beams.

For the best picture, the beams should be aligned at each of the 5 adjustment positions which appear on the screen. You can perform the following procedure whenever you think that the light beams are out of alignment.

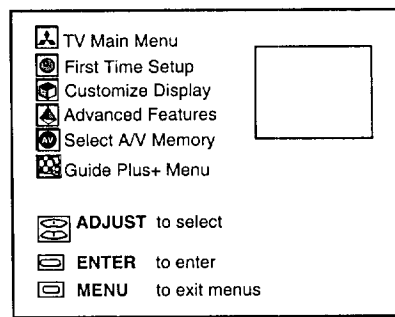

1 Press the MENU button on the remote control. The Main Menu will appear on the screen.

2 Use the ADJUST buttons to select "First Time Setup." Press ENTER/EXCH.

3 You will see the "First Time Setup" screen. Use the ADJUST buttons to select "Convergence." Press ENTER/EXCH.

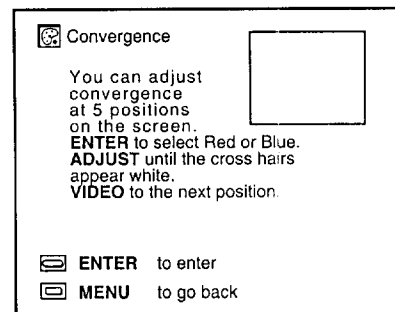

4 You will see the "Convergence" screen. Read the instructions that appear on the screen. Press the ENTER/EXCH button to proceed.

5 Press ENTER/EXCH to select a color to align and use the ADJUST buttons to align the color you selected (red or blue) with the green lines. When they are properly aligned, the vertical and horizontal lines will merge into a single white cross.

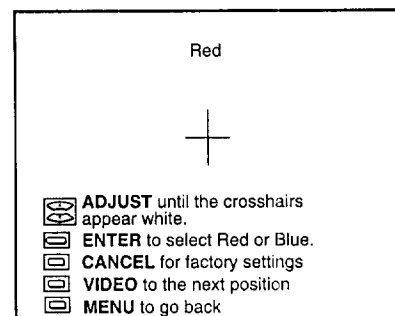

6 Next, use the VIDEO button to select the next position on the screen. Use the ADJUST buttons to align the colors. Adjust convergence at each of the 5 positions using VIDEO and ADJUST buttons.

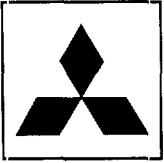

Selecting the menu type

You can display the on-screen menus in one of two ways. The “Standard Menu”, which is illustrated in this manual, provides step-by-step instructions for all features. The “Advanced Menu” lets you select each feature directly by its name and icon.

Your TV’s normal setting is the “Standard menu”. To switch between the Standard and Advanced menus:

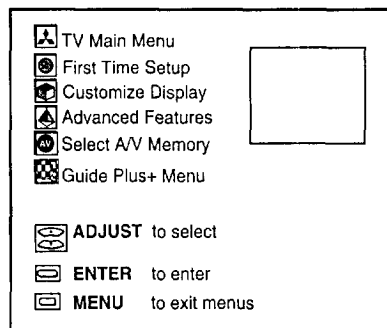

1 Press the MENU button on the remote control. The Main Menu will appear on the screen.

2 Use the ADJUST buttons to select “Customize Display”. Press ENTER/EXCH.

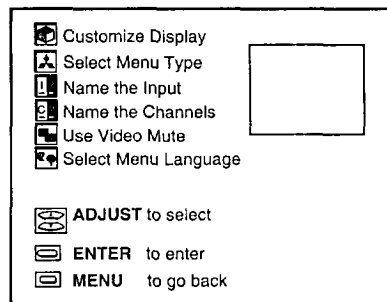

3 You will see the “Customize Display” menu. Use the ADJUST buttons to “Select Menu Type”. Press ENTER/EXCH.

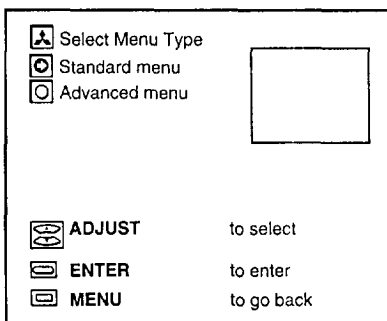

4 Use the ADJUST buttons to select “Standard menu” or “Advanced menu”.

5 Press the ENTER/EXCH or MENU button.

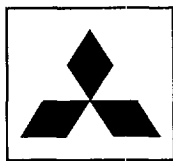

Selecting the menu type (cont.)

If you select the “Standard menu”, the screen will return to the “Customize Display” menu. If you selected the “Advanced menu,” the screen will show the menu illustrated below.

To operate the Advanced menu, use the ADJUST buttons to highlight the icon of the feature you want to use, then press ENTER/EXCH. The name of the highlighted icon appears at the bottom of the screen. This menu will disappear in about five minutes if you do not select an item.

If you wish to return to the standard menu, use the ADJUST buttons. Choose the “Select Menu Type” icon and press ENTER/EXCH. This gives you the option of re-selecting the standard menu.

The Advanced Main Menu

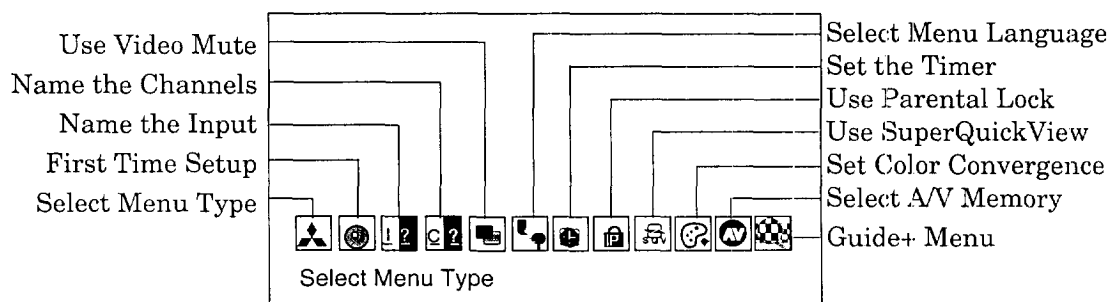

The feature name of the highlighted icon appears here.



Naming the input

This feature allows you to name the inputs so that you can keep track of components you have connected to your TV. For example, you might name one input "VCR", and another one "DISC." After naming, the new name will appear on the screen display. The original names are: "Input-1," "Input-2" and "Input-3".

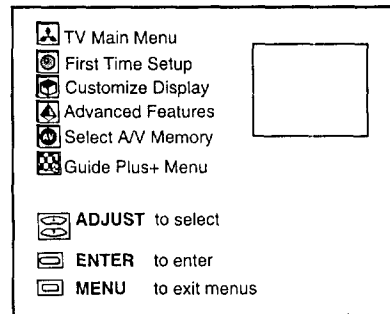

1 Press the MENU button on the remote control. The Main Menu will appear on the screen.

2 Use the ADJUST buttons to select "Customize Display." Press ENTER/EXCH.

3 You will see the "Customize Display" screen. Use the ADJUST buttons to select "Name the Input." Press ENTER/EXCH.

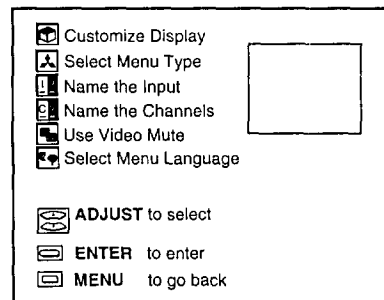

4 Use the ADJUST buttons to select the input you want to name (Input-1, Input-2 or Input 3). Press ENTER/EXCH.

5 Use the ADJUST buttons and the ENTER/EXCH button to select each letter in the new name.

You can use the letters (A - Z), numbers (0 - 9), or symbols (: / . , () ! " # \$ % & ' blank + ; < = > ? blank -) for the new name.

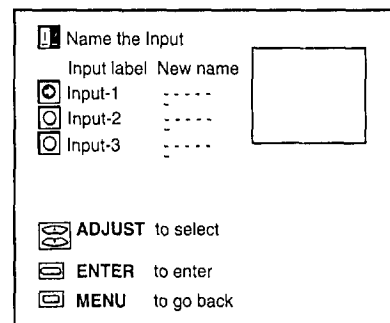

If you press the CANCEL button while setting the name, you will move one position back. You can clear the entire name by pressing CANCEL when the first position is underlined.

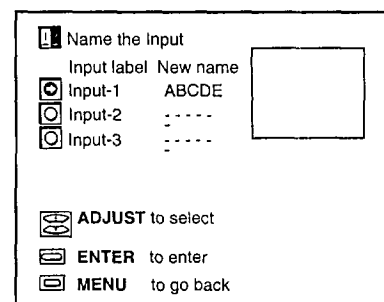

6 When you are finished, press the MENU button. The screen will return to the "Customize Display" menu.

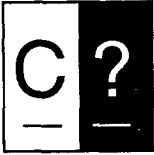

Naming the channels



TV GUIDE Plus+ users do not need to perform the steps below for ANT-A if TV GUIDE Plus+ is used. However, if ANT-B will be used you can name the channels on ANT-B. Refer to the *TV GUIDE Plus+ Operating Guide*.

To help you keep track of the many channels available, you can name up to 30 of the channels your TV receives. After you enter a name, it will appear on screen, next to the channel number.

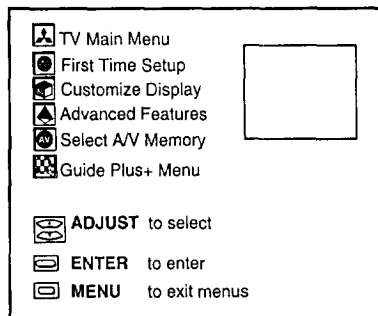

1 Press the MENU button on the remote control. The Main Menu will appear on the screen.

2 Use the ADJUST buttons to select "Customize Display". Press ENTER/EXCH.

3 You will see the "Customize Display" screen. Use the ADJUST buttons to select "Name the Channels". Press ENTER/EXCH.

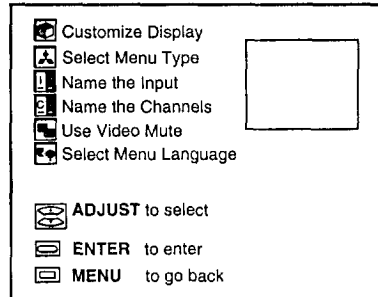

4 Use the ADJUST buttons to select an antenna (A or B). Press ENTER/EXCH.

5 Use the ADJUST buttons channel controls or number buttons to select the channel you want to name. Press ENTER/EXCH to store the channel number in memory.

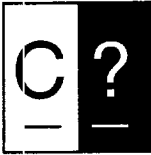

Naming the channels (cont.)

Name the Channels
Antenna : A
(Indoor/outdoor)
Channel : ----
New name : ----

ADJUST to select
ENTER to enter
MENU to go back

- ⑥ Use the ADJUST buttons and the ENTER/EXCH button to select each letter in the new name. You can use letters (A – Z), numbers (0 – 9), or symbols (: / . , () ! " # \$ % & ' blank + ; < = > ? blank -) for the new name.

Name the Channels
Antenna : A
(Indoor/outdoor)
Channel : 003
New name : ----

ADJUST to select
ENTER to enter
MENU to go back

If you press the CANCEL button while setting the name, you will move one position back. You can clear the entire name by pressing CANCEL when the first position is underlined.

- ⑦ When you are finished, press the HOME button to return to normal viewing.

- ▷ **Important:** The name you set will appear instead of the call letters being supplied by Extended Data Services (XDS).
- ▷ **Important:** Message “Memory over!” will indicate that the memory is full. If the memory is full and you want to name a channel, you must use the above steps to clear the name for an existing channel. You can then select the new channel to name.

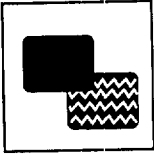

Using video mute

When you use the video mute functions, your TV will display a blue screen whenever it is receiving a weak external signal or no signal at all from Input-1, Input-2, or Input-3. If you want to try viewing a weak external signal, you can turn the video mute off.

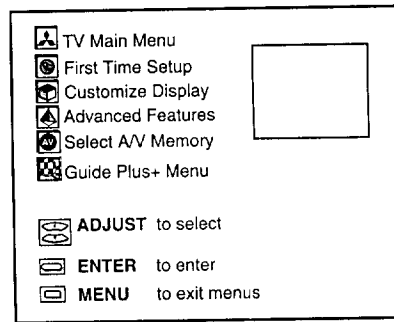

1 Press the MENU button on the remote control. The TV Main Menu will appear on the screen.

2 Use the ADJUST buttons to select "Customize display". Press ENTER/EXCH.

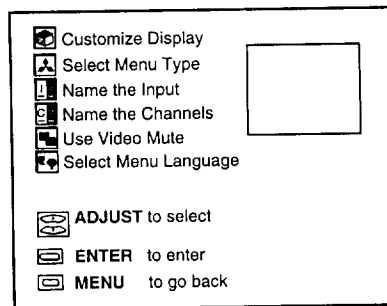

3 Use the ADJUST buttons to select "Use Video Mute". Press ENTER/EXCH.

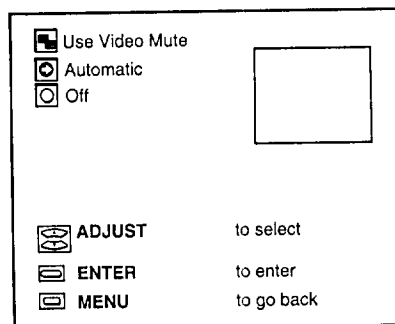

4 Using the ADJUST buttons, select "Automatic" to turn video mute on or to "Off" to turn video mute off.

Press ENTER/EXCH or MENU button to return to the "Customize Display" menu.

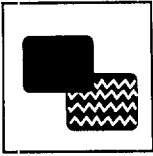

Selecting the menu language

This TV allows you to display the on-screen menus in either of two languages: English or Spanish (Español).

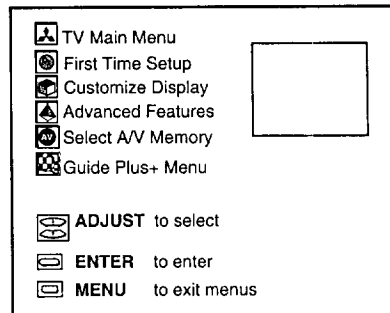

1 Press the MENU button on the remote control. The TV Main Menu will appear on the screen.

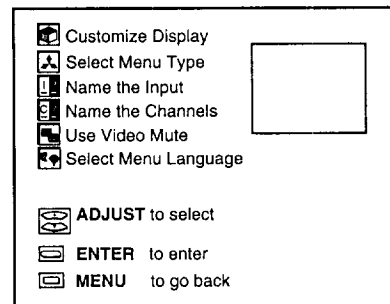

2 Use the ADJUST buttons to select "Customize Display." Press the ENTER/EXCH button.

3 Use the ADJUST buttons to select "Select Menu Language." Press the ENTER/EXCH button.

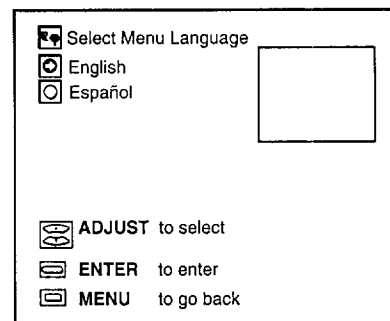

4 Use the ADJUST buttons to select the language for the on-screen menu.

5 Press the ENTER/EXCH or MENU button to return to the "Customize Display" menu.

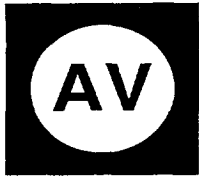

Selecting the A/V memory categories

Your TV has five A/V memory categories. Each A/V memory category contains preset picture and sound settings to best suit the type of program you are watching. You can adjust the settings for these memories as much as you like.

The five memories are:

Standard - - - normal picture and sound

Music - - - vivid picture and lively sound

Movie - - - soft picture and strong sound

News - - - optimized for listening to speech in news programs

Sports - - - vivid picture and strong sound

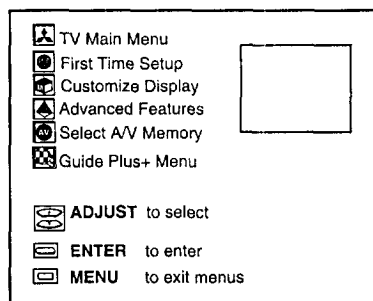

1 Press the MENU button on the remote control. The Main Menu will appear on the screen.

2 Use the ADJUST buttons to select "Select A/V Memory." Press ENTER/EXCH.

3 You will see the Select A/V Memory screen.

4 Use the ADJUST buttons to select the desired A/V memory position.

5 Press the MENU button to return to the MAIN MENU.

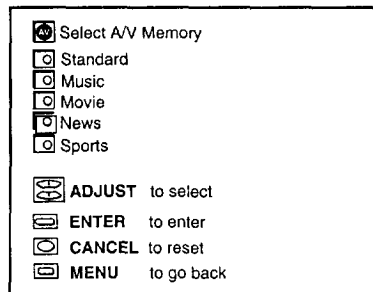

▷ **Important:** A/V memory positions are specific to the currently selected input. When you change your input, the last A/V memory position used with that input is automatically selected. See "Selecting the Input Source" in this chapter for information on choosing your input.

Although the preset A/V memory categories are designed to optimize the picture and sound quality for different types of programming, you can adjust individual settings (tint, treble, etc.) for any memory. See "Customizing the A/V Memory Settings" in this chapter for information on adjusting individual video and audio settings.

▷ **Important:** The following settings are independent of the individual A/V Memory, and any adjustments apply to all five A/V Memories:

Audio settings

- Listen to
- Balance
- Speaker ON/OFF
- Volume
- Monitor Out

Video settings

- Background GRAY/BLACK
- Closed Captions
- Instant Info

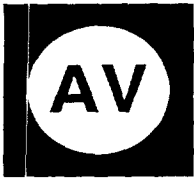

Selecting the A/V memory categories (cont.)

▷ **Important:** The “Select A/V Memory” menu is not available for locked channels until the channel has been unlocked.

Using the AV MEMORY button to select an A/V Memory

You can use the A/V MEMORY button on the remote to select a new A/V Memory to use or adjust.

- 1 Press the A/V MEMORY button on the remote to display a list of A/V Memories.
- 2 Use the ADJUST up or down buttons to select a new memory, or if you wish to change the setting in the selected memory, proceed with step 3.
- 3 If you wish to change an individual setting in the selected A/V Memory press the ENTER/EXCH button once to display the video settings or press the ENTER/EXCH button twice to display the audio settings.
- 4 Use the ADJUST up or down buttons to select the setting you would like to adjust. *Do Not Press* ENTER/EXCH, instead use the ADJUST left or right buttons to change the setting.
- 5 Press the HOME button to use the selected memory and remove the display from the screen.

resetting an A/V memory

If you have changed the adjustments of an AV memory and would like to return these settings to the original factory adjustments:

- 1 Press the MENU button on the remote control. The Main Menu will appear on the screen.
- 2 Use the ADJUST buttons to select “Select A/V Memory.” Press ENTER/EXCH.
- 3 You will see the Select A/V Memory screen.
- 4 Use the ADJUST buttons to select the desired A/V memory position.
- 5 You can press the CANCEL button to reset many of the audio and video settings for the selected A/V memory position to their factory settings.

Pressing CANCEL will not affect changes made to volume, the “Listen to:” function (Stereo/ SAP/Mono), speaker (off/on), background (black/gray), and closed captioning.

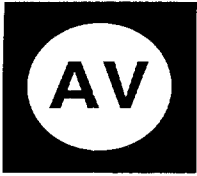

Customizing the A/V memory settings

You can adjust the individual video and audio settings for each of the five preset A/V memory positions to select your desired picture and sound qualities. This section provides descriptions of each video and audio setting, and explains how to adjust them for the A/V memory positions. See “Selecting the A/V memory position” in this chapter for more information.

- ▷ **Important:** You can cancel any adjustments made to an A/V memory position and return it to the factory settings. See “Selecting the A/V memory position” in this chapter for more information.

Adjusting the picture

This section contains descriptions for each video setting and explains how to adjust them for the A/V memory positions.

descriptions of video settings

IRIS™ is the Intelligent Room Illumination (light) Sensor. You may choose to set it on or off. When IRIS is on, it will automatically optimize picture contrast and brightness for the room lighting, and the manual brightness and contrast cannot be adjusted.

NOTE: IRIS is only available for use in the standard A/V memory video mode.

Tint provides a scale that adjusts the proportion of red to green in the picture. This determines the delicate tones of color.

Color provides a scale that determines the intensity of the color.

Contrast provides a scale that controls the level of white-to-black in the picture. When the contrast is low, you will be able to see the variety of shades in the darker images on the screen. When the contrast is high, the screen’s dark images will appear more uniformly black, but this will also make the colors on the screen seem more vibrant.

Brightness provides a scale that controls the overall brightness of the picture.

Sharpness provides a scale that adjusts the detail and clarity of the picture.

Color temp (Color temperature) allows you to set how the TV will display white images. Your choices are “Low,” “High,” or “Middle.”

- With the **Low** setting, white images on-screen will have a warm cast to them. This setting represents the 6500°K industry standard.
- With the **High** setting, white images on-screen will have a cool cast to them. This setting may provide the most realistic picture under bright lighting.
- With the **Middle** setting, white images on-screen will be balanced between the above warm and cool setting.



Customizing the A/V memory settings (cont.)

Background allows you to select the background color from choices of Black or Gray for the closed caption display and the audio/video functions display.

CC function is used to control the closed caption decoder. For details, see "Using the closed caption decoder" in this chapter.



Instant Info allows special information broadcast from TV GUIDE Plus+ and host channels to be viewed on-screen. It can be turned "on" or "off" in any memory setting. For details, see the *TV GUIDE Plus+ Operating Guide*.

Adjusting the video settings

You can adjust the video settings for any A/V memory position using either the MENU or VIDEO buttons on the remote control.

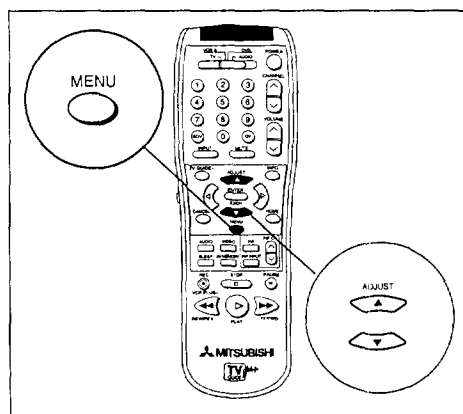

access with the MENU button

- 1 Press the MENU button on the remote control. The TV Main Menu appears on the screen.
- 2 Use the ADJUST buttons to choose "Select A/V Memory". Press ENTER/EXCH.
- 3 The five A/V memory positions appear. Select the A/V position to adjust by pressing the ADJUST up/down buttons. When the desired position is selected, press ENTER/EXCH.
- 4 The video settings for the selected A/V memory position display. Use the ADJUST up/down buttons to select the setting to change. Do **not** press ENTER/EXCH.

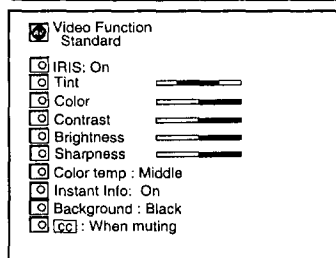
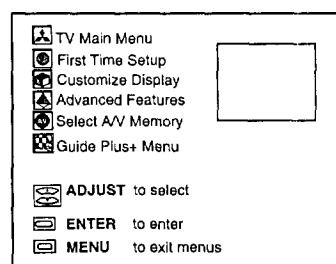

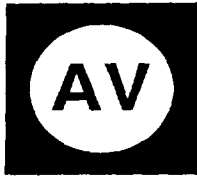

Customizing the A/V memory settings (cont.)

- 5 Press either the left or right ADJUST button.
- 6 The setting appears at the bottom of the screen.
- 7 While the setting is still on the screen, use the ADJUST right/left buttons to adjust it.

access with the video button

The VIDEO button selects the video settings for the *currently selected A/V memory category*. The currently selected A/V memory category displays on the screen above the video adjustment display when you press the Video button. See “Selecting the A/V Memory Categories” in this chapter.

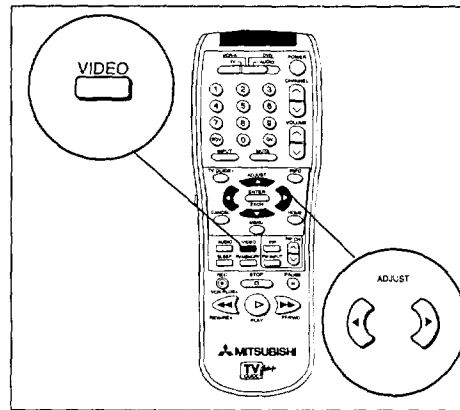

- 1 Press the VIDEO button repeatedly until the desired setting displays at the bottom of the screen.
- 2 While the setting is still on the screen, use the ADJUST right/left buttons to change the function's setting.
- 3 The setting will disappear from the screen after a few seconds. You cannot adjust a setting if it is not on the screen.

▷ **Important:** If you use the VIDEO button, any adjustments made to video settings are memorized into the currently selected A/V memory position (Standard, Movie, Music, News, Sports). To reset the video settings to their factory settings, see “Selecting the A/V Memory Categories” in this chapter.

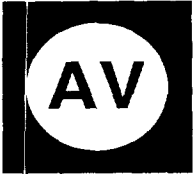

Customizing the A/V memory settings (cont.)

Using closed caption decoder

Many broadcasters now supply closed captioning information along with their regular broadcasts. Your TV can decode that information and display it on the TV screen.

Closed captioning was initially designed so that those with hearing difficulties could more fully enjoy viewing television. However, closed captioning can also be used in other ways, such as:

- helping children learn to read
- learning a foreign language
- using the television without disturbing others

There are two types of captioning that broadcasters can send: standard and text.

Standard captioning is related to the program that is being shown. Standard captioning usually follows the dialogue of the characters on-screen and only displays when the broadcaster is sending the closed captioning.

Text captioning often contains information such as weather or news. Text captioning blocks out your view of the program you are watching.

Your TV can decode four different standard captioning signals and four different text captioning signals from each TV station. However, each station may be broadcasting only one or two captioning signals, or none at all.

When setting the decoder you can choose to display:

- one of four standard captioning signals (**CC**:1, **CC**:2, **CC**:3, **CC**:4)
- one of four text captioning signals (**CC**: Text 1, **CC**: Text 2, **CC**: Text 3, **CC**: Text 4)
- captions when muting (**CC**: When Muting)
- turn the captions off (**CC**: Off)

If you select “**CC**: When Muting,” the standard captioning signal (**CC**:1) will appear whenever you use the MUTE button.

- ▷ **Important:** If you set the decoder to a “standard” caption setting or “when muting” and tune to a broadcaster that is not sending a caption signal, no captions will appear.
- ▷ **Important:** The content of captions are determined by the broadcaster. If your captions show strange characters, misspellings, or odd grammar, it is not a malfunction of the TV.

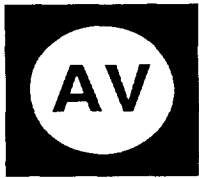

Customizing the A/V memory settings (cont.)

adjusting the closed caption decoder

You can access the closed caption decoder screen using the MENU or A/V MEMORY button. When adjusting the closed caption decoder, you can use the buttons on the remote control.

access with the MENU button

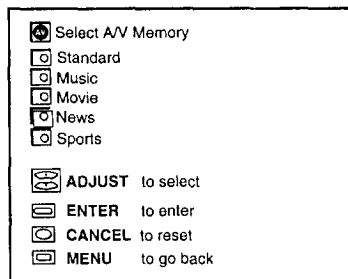

1 Press the MENU button on the remote control. The TV Main Menu will appear on the screen.

2 Use the ADJUST up/down buttons to choose "Select A/V Memory". Press ENTER/EXCH.

3 Use the ADJUST up/down buttons to select the A/V Memory you want to modify. Press ENTER/EXCH.

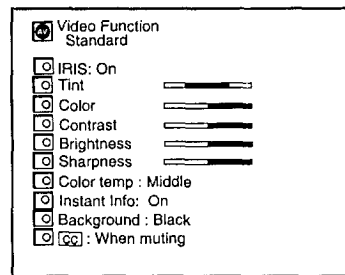

4 Select the closed caption display by pressing the ADJUST up/down buttons. Press the adjust right or left button to select the desired closed caption signal. Wait until the display appears. That option is now selected.

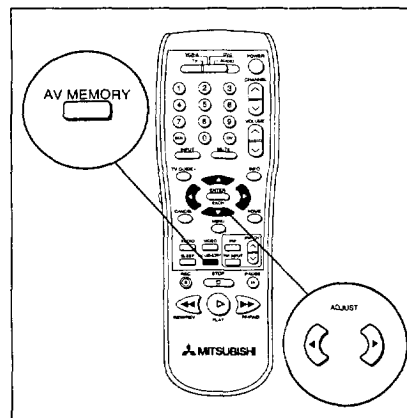

access with the A/V MEMORY button

1 Press the A/V MEMORY button. Press ENTER/EXCH. Next press ADJUST up/down until the closed caption menu option displays.

2 Press the ADJUST right/left buttons to select the desired closed caption signal. See previous page for explanation of caption settings.

▷ **Important:** If you cannot display any captions on the screen, please keep in mind that not all broadcasters, video tapes, or laserdiscs supply closed caption signals. Additionally, captions might not appear if you are playing a video tape that is worn or deteriorated, or starting to play a laserdisc or video tape from still or search mode.

▷ **Important:** The closed caption setting you choose will apply to all five A/V Memory settings.

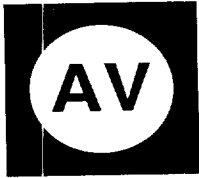

Customizing the A/V memory settings (cont.)

Adjusting the sound

This section contains descriptions for each audio setting and explains how to adjust them for the A/V memory positions.

descriptions of audio settings

Listen to: allows you to determine how your TV will receive an audio signal and play back the sound that you hear. You can set this function to “Stereo,” “S.A.P.” or “Mono.”

- For almost all situations, you should choose **Stereo**. With this setting, the TV will play stereo broadcasts in stereo and mono broadcasts in mono. If a channel is broadcasting in stereo, the word “Stereo” will display when you tune to that channel.
- Some TV stations will broadcast second audio program, or **S.A.P.** signal. This signal is an additional soundtrack that you can't hear during normal TV viewing. An S.A.P. signal might be related to the program you are watching, such as a soundtrack in a foreign language, or it might be unrelated; for example, a weather report. If a channel is broadcasting an S.A.P. signal, the letters “SAP” will appear on-screen when you tune to that channel. Choose “Listen to: SAP” to hear the S.A.P. signal.
- Use the **Mono** setting if you are receiving a weak audio signal. This setting will reduce background noise. However the TV will only play in mono, even if the program you are watching is in stereo.

Bass enhances or reduces low frequency sound.

Treble enhances or reduces high frequency sound.

Balance adjusts the level of sound between the left and right speakers. Adjust the scale until the sound seems to come equally from both speakers.

Surround creates simulated stereo and surround effects. You can set this setting to “Off,” “Simulate” or “Hall.”

- Select **Off** if you do not want to use any surround effects.
- Select **Simulate** if you are watching a non-stereo program. Your TV will create a simulated stereo effect.
- Select **Hall** if you are watching a stereo program. Your TV will create a simulated surround effect, making the sound seem to extend around and behind you using the TV's internal speakers.

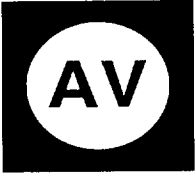

Customizing the A/V memory settings (cont.)

Speaker allows you to turn the TV's internal speakers on or off.

- Choose **On** if you want to play the TV's sound through the TV's built-in speakers.
- Choose **Off** if you connected your audio system to your TV and you want to play the sound of your TV through the audio system.

Monitor Out determines how the TV will send an audio signal to an audio system or home theatre receiver. Your choices are "Variable" or "Fixed."

- If you choose **Fixed**, the TV will send out an audio signal at a fixed volume level. The level will not change when you adjust the TV's volume. Use the controls on your audio system to adjust the volume. The fixed setting is most useful when you can control the audio system's volume with a remote control.
- If you choose **Variable**, the TV's audio output will change when you adjust the TV's volume. If you use this setting with an audio system, turn the TV's volume all the way down, set the audio system's volume to an average setting and then adjust the TV's volume until you can hear the signal.

Level Sound allows the TV to automatically equalize the volume level of programs that contain significant sound level differences from one segment to another; for example, from regular programming to commercials. To receive the best audio fidelity for music programs, you may want to turn this setting off.

▷ **Important:** For proper tone and volume balance, you may wish to turn off the TV's speakers when using an external audio system.

▷ **Important:** Set the surround setting to "OFF" when using an A/V receiver with Dolby® Pro Logic Surround.

"Dolby," "AC-3," "Pro Logic" and the double-D symbol are trademarks of Dolby Laboratories Licensing Corporation. Copyright 1992 Dolby Laboratories, Inc. All rights reserved.



Customizing the A/V memory settings (cont.)

Adjusting the audio functions

You can adjust the audio settings for any A/V memory position using the MENU or AUDIO buttons on the remote control.

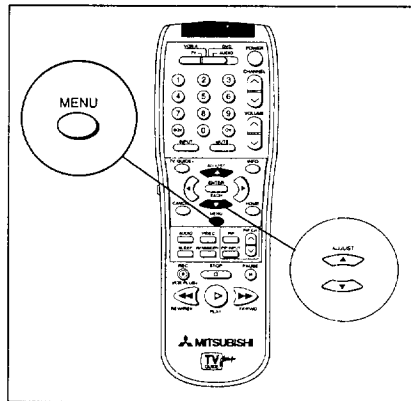

access with the MENU button

1 Press the MENU button on the remote control. The TV Main Menu will appear on the screen.

2 Use the ADJUST buttons to choose "Select A/V Memory". Press ENTER/EXCH. The five A/V memory positions will appear. Select the A/V position by pressing the ADJUST up/down buttons. Press ENTER/EXCH twice to display the settings for the selected audio mode.

3 The audio settings for the selected A/V memory position are displayed. Use the ADJUST up/down buttons to select the setting to change. Do **NOT** press ENTER/EXCH.

4 Press either the left or right ADJUST button.

5 The setting appears at the bottom of the screen.

6 While the setting is still on the screen, use the ADJUST right/left buttons to adjust it.

7 The functions disappear from the screen after a few seconds. You cannot adjust a function if it is not on the screen.

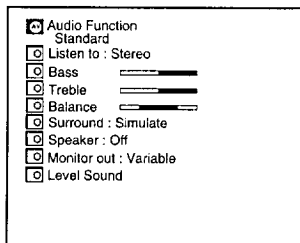
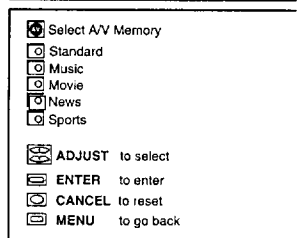
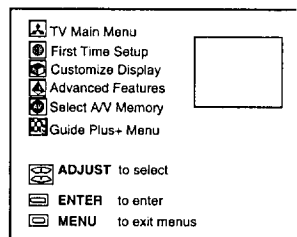

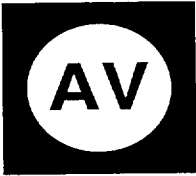

Customizing the A/V memory settings (cont.)

access with the AUDIO button

The AUDIO button changes the audio settings for *the currently selected A/V memory category*. The currently selected A/V memory category will display on the screen above the audio adjustment display when the Audio button is pressed. See “Selecting the A/V Memory Position” in this chapter.

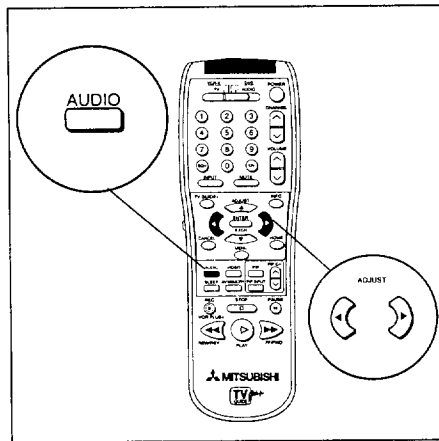

- 1 Press the AUDIO button until the desired function displays on the bottom of the screen.
- 2 While the function is still on the screen, use the ADJUST right/left buttons to modify the function's setting.
- 3 The functions disappear from the screen after a few seconds. You cannot adjust a function if it is not on the screen.

- ▷ **Important:** If you use the AUDIO button, any adjustments made to audio functions are memorized into the currently selected A/V memory position (Standard, Movie, Music, News, Sports). To reset the audio functions to their factory settings, see “Selecting the A/V Memory” in this chapter.
- ▷ **Important:** Pressing the ADJUST right/left button while on a normal picture (with no menus showing) will select the last adjusted video or audio setting.

◆ Using the Advanced Features

This section explains how to use some of the more advanced features. You'll learn about:

- **Setting the timer**
- **Using the parental lock**
- **Using SuperQuickView™**

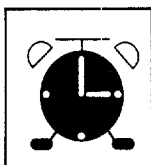

Setting the timer

This special feature allows you to program the TV to turn on automatically at a specific time to the channel that you set.

▷ **Important:** The clock must be set prior to setting the timer.

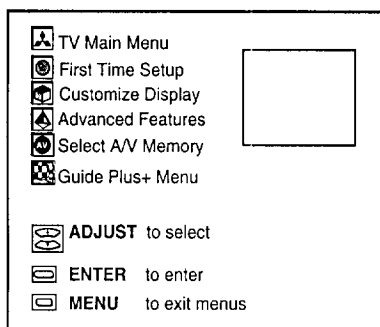

To set the timer:

❶ Press the MENU button on the remote control. The Main Menu will appear on the screen.

❷ Use the ADJUST buttons to select “Advanced Features.” Press ENTER/EXCH.

❸ You will see the “Advanced Features” screen. Use the ADJUST buttons to select “Set the Timer.” Press ENTER/EXCH.

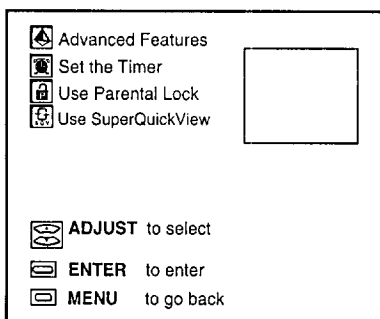

▷ Important:

If you have not set the time, you will be automatically routed to the “Set the clock” menu.

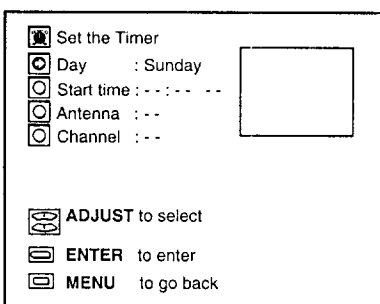

❹ Use the ADJUST buttons and the ENTER button to set Day (Sun ~ Sat, Mon-to-Fri, or Everyday), Start time, Antenna, and Channel.

After setting the timer, the Program Timer indicator will blink in green while the TV is turned off.

If you press the CANCEL button while setting the timer, the arrow will move to the previous item. To clear the timer, press CANCEL when “Day” is selected.

▷ **Important:** When the timer turns the TV on, the on-screen display will flash. If you do not press any remote control button within 5 minutes after the TV turns on, the TV will automatically turn off. Press a function button (such as the INFO button) to keep the TV on and to stop the flashing display.



Using the parental lock

This special feature allows you to lock the entire TV during a certain time period or lock up to ten individual channels. You *cannot* lock the TV and lock individual channels at the same time. When you turn on the lock, you enter a 4-digit secret code that will allow you to turn off the lock later.

If you try to turn on a locked TV, view a locked channel or the locking “time period” begins, you will see a message asking you to enter the secret code. If you don’t enter the code within five minutes, the TV will turn off or change to an unlocked channel.

If you enter your secret code, the message will disappear and the lock will be turned off temporarily. However, the TV or channels will be locked again after you turn off the TV. This will continue until you turn the lock off permanently. To turn the lock off permanently, follow the procedure “Canceling or Changing Parental Lock” in this section.

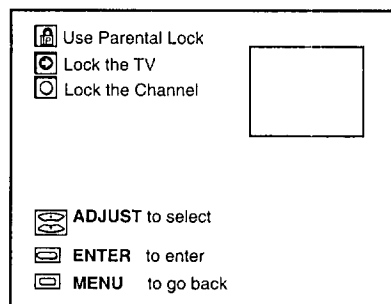
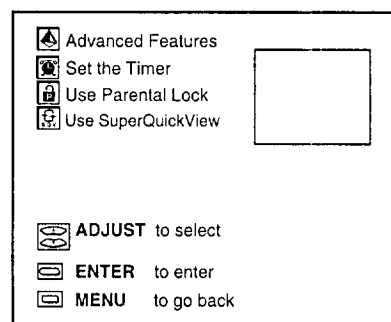
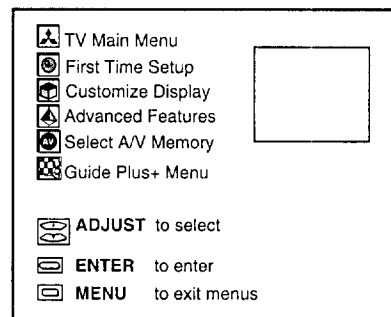

using parental lock

- 1 Press the MENU button. The Main Menu will appear.
- 2 Use the ADJUST buttons to select “Advanced Features.” Press ENTER/EXCH.
- 3 You will see the “Advanced Features” screen. Use the ADJUST buttons to select “Use Parental Lock.” Press ENTER/EXCH.
- 4 You will see the “Use Parental Lock” screen. Use the ADJUST buttons to select “Lock the TV” or “Lock the Channel.” Press ENTER/EXCH.

If you selected “Lock the TV,” see *Locking the TV* on the next page. If you selected “Lock the Channel,” see *Locking the Channel* in this chapter.

▷ **Important:** If you turn the parental lock on, you cannot use the timer.



Using the parental lock (cont.)

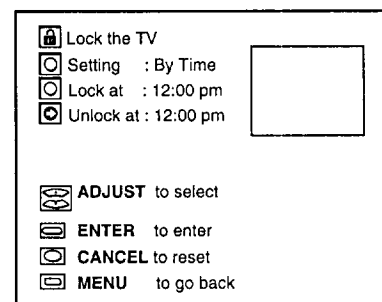
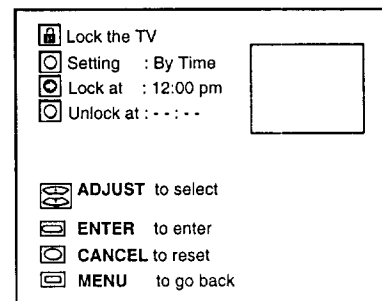
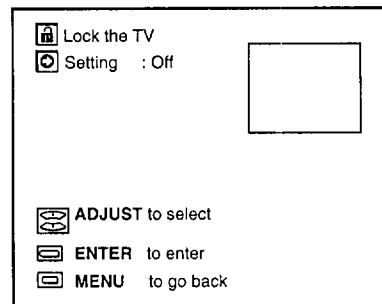
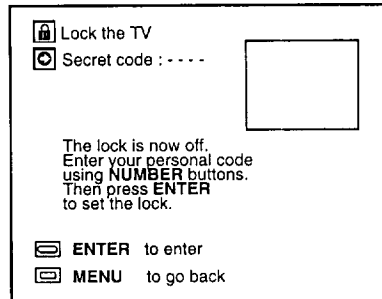

locking the TV

- 1 The message for locking the TV will appear.
- 2 Enter a four-digit secret code using the number buttons (0-9); then, press the ENTER/EXCH button.

You can cancel the code if you press CANCEL before you press ENTER/EXCH.

- 3 Use the ADJUST up/down buttons to select a setting: Off, Always On, or By Time. Press ENTER/EXCH.

If you select the setting “By Time”

- 1 The cursor will move to “Lock at.” Use the ADJUST buttons to set the time at which you want to lock the TV. Press ENTER/EXCH.
- 2 Use the ADJUST buttons to set the time at which you want to unlock the TV. Press ENTER/EXCH. The screen will return to the “Advanced Features” menu.

If you want the lock to be in effect all the time, set the same “Lock at” time as you set for the “Unlock at” time, or select “Always On”.

- 3 Press HOME to exit the menus.
- 4 When you turn on a locked TV or if the lock’s “time period” begins, you will be asked to enter your four-digit secret code. Enter the code to temporarily disable the lock. The lock will be enabled again when you turn the TV off.

▷ **Important:** The TV will be locked at all times *if* you set the lock by time but do not set the TV’s clock.



Using the parental lock (cont.)

locking the channel

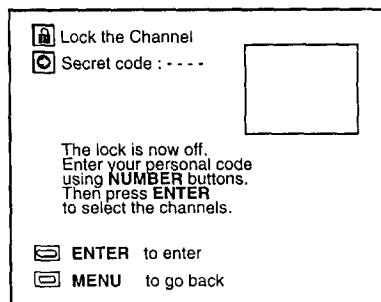

1 The message "Lock the Channel" will appear.

2 Enter a four-digit secret code using the number buttons (0-9); press ENTER/EXCH.

You can cancel the code if you press CANCEL before you press ENTER/EXCH.

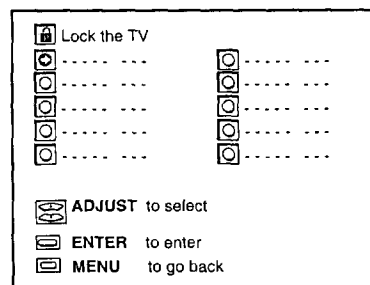

3 You will see the channel lock set up screen. Use the four ADJUST buttons to select a position. Press ENTER/EXCH.

4 Use the ADJUST buttons to select the antenna (ANT-A or ANT-B) that has the channel you want to lock. Press ENTER/EXCH.

5 Use the CHANNEL or ADJUST buttons to select the channel you want to lock. Press ENTER/EXCH.

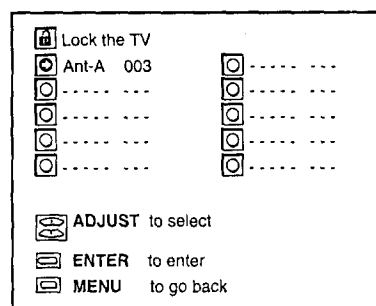

6 Repeat the steps above to lock additional channels. When you are finished, press the HOME button to turn off the menus.

7 When you try to view a locked channel, you will be asked to enter your four-digit secret code. Enter the code to temporarily disable the lock. The lock will be enabled again when you turn the TV off.

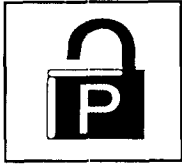

Using the parental lock (cont.)

canceling or changing parental lock

- 1 Press the MENU button. The Main Menu will appear on the screen.
- 2 Select “Advanced Features” using the ADJUST up/down buttons. Press ENTER/EXCH.
- 3 Select “Use Parental Lock” using the ADJUST button. Press ENTER/EXCH.
- 4 Enter the four digits of your secret code using the number buttons (0-9). Press ENTER/EXCH.

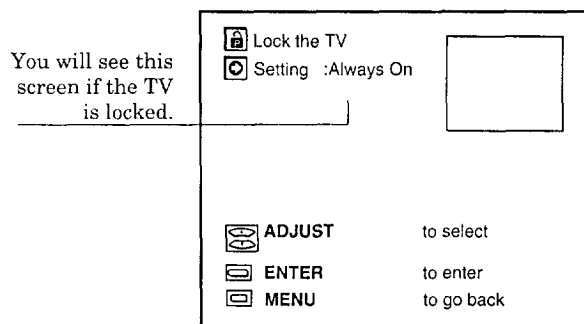

- 5 If you have locked the TV, use the ADJUST up/down buttons to select the setting “Off” to turn off the lock.

If you have locked the channel, use the ADJUST buttons to place the cursor next to the channel whose lock you want to cancel. Press ENTER/EXCH.

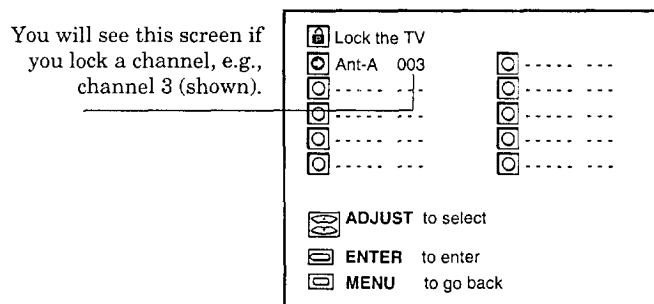

- 6 Press the CANCEL button to unlock that channel, or use the ADJUST buttons to change the channel to a new one.

- 7 Press MENU to return to the “Advanced Features” menu.

> **Important:** If you forget your four-digit secret code, please see the Appendix *Procedure for Bypassing the Parental Lock*.



Using SuperQuickView™

SuperQuickView allows you to cycle through a list of up to ten channels with the SQV button. Use the menu to add channels to the list or to remove channels from the list. You can also add channels directly to the list using only the remote control's SQV button.

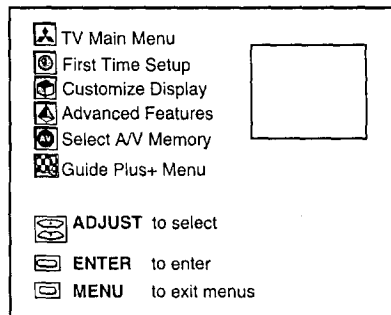

customizing the SuperQuickView list with the menu

1 Press the MENU button on the remote control. The Main Menu will appear on the screen.

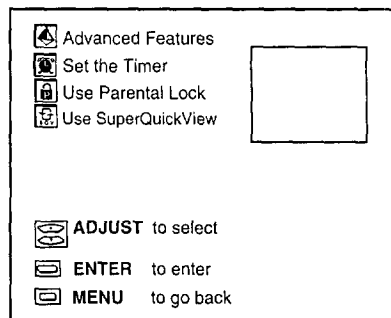

2 Use the ADJUST up/down buttons to select "Advanced Features." Press ENTER/EXCH.

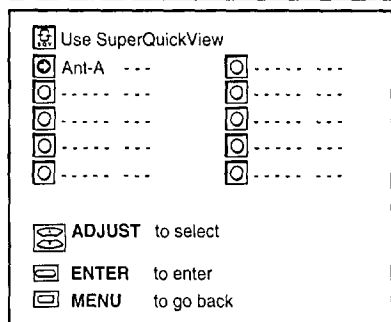

3 You will see the "Advanced Features" screen. Use the ADJUST up/down buttons to select "Use SuperQuickView." Press ENTER/EXCH.

4 You will see the "SuperQuickView" screen. Use the ADJUST buttons to select a position in the list. Press ENTER/EXCH.

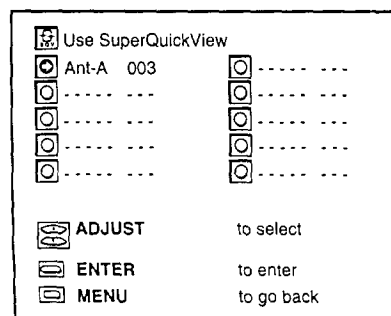

5 Use the ADJUST up/down buttons to select the antenna (ANT-A or ANT-B). Press ENTER/EXCH. You can clear the entry by pressing CANCEL.

6 Use the CHANNEL, number or ADJUST buttons to select the channel to add to the list. Press ENTER/EXCH.

7 Repeat steps 4 through 6 to customize the SuperQuickView memory.

8 Press MENU to exit this menu.



Using SuperQuickView™ (cont.)

adding channels directly to the list with the remote control's SQV button

- ➊ Use the CHANNEL buttons or number buttons to tune the TV to the channel you want to add to the list.
- ➋ Press and hold the SQV button for about 2 seconds. The letters “SQV” will appear under the channel number, indicating that the channel has been added to SuperQuickView memory.

▷ **Important:** Once you've added a channel to the SQV memory, the letters “SQV” appear under the channel number any time the channel number is displayed, even if you tune to the channel using another method.

▷ **Important:** If the “SQV” indicator begins to flash when you try to add a channel to the list using the SQV button, then the SuperQuickView memory is full. In this case, you will have to remove an existing channel to add a new channel.

removing channels from the SQV list using the menu

Use steps ➊ - ➋ from “customizing the SuperQuickView list with the menus” on the preceding page to select and cancel the channel from the SuperQuickView list.

removing the channels from the SQV list with the remote control's CANCEL button

- ➊ Press the SQV button repeatedly to select the channel to be removed from the list.
- ➋ While the channel number and SQV indicators are still displayed on the screen, press the CANCEL button. When the SQV indicator disappears, the channel has been canceled from the SuperQuickView list. If you wait until the channel and SQV indicators disappear automatically, then the CANCEL button will not remove the channel from the list.



CHAPTER FOUR
Using the Special Features

In addition to the basic and advanced features explained in the previous chapter, your TV offers some special features that you can use when operating your TV. This chapter contains the following topics:

- ◆ **Understanding the On-Screen Displays**
- ◆ **Using the Sleep Timer**
- ◆ **Using the Picture-in-Picture (PIP) Modes**
- ◆ **Using the Active A/V Network Feature**

◆ Understanding the On-Screen Displays

Your TV provides an on-screen summary of the current settings for the TV or cable channels, as well as the information related to Extended Data Services (XDS) or channel and program information provided by TV GUIDE Plus+. XDS allows broadcasters to supply you with the current time, channel information (such as call letters and the network name), and program information (such as the program name and program description).

To view this information, press the information button (INFO) on the remote control.



Some of the screen information shown below will not appear on ANT-A if TV GUIDE Plus+ has been installed.

If the source of the main picture is an antenna:

```

network name ANT-A 023 ESPN
Stereo & SAP
SQV QV

                                A023
program name [ ]
program description [ ]
Thursday 10:23 am
    
```

The first setting shows:

- antenna (A) and channel number (23)
- the channel's call letters or name
- stereo and SAP are available
- channel programmed into SuperQuickView™ memory
- channel is the QuickView (QV) channel
- PIP input source is Antenna A, Channel 23.
- current day of the week
- current time

If the source of the main picture is an input:

```

                                Input-1
                                S-VIDEO

                                A023
                                [ ]
Thursday 10:23 am
    
```

This second setting shows:

- the input name (Input-1)
- S-video cable is connected
- PIP input source is Antenna A, Channel 23
- current day of the week
- current time

▷ **Important:** XDS program information will only be present if the broadcaster is supplying the information.

The on-screen displays will automatically disappear after about 10 seconds.

◆ Using the Sleep Timer

This special feature allows you to set the TV to turn off automatically. You can set the TV to turn off after a period of time ranging from 10 to 120 minutes, in ten minute intervals. In this section you will learn:

- **Setting the sleep timer**
- **Changing or canceling the sleep timer**

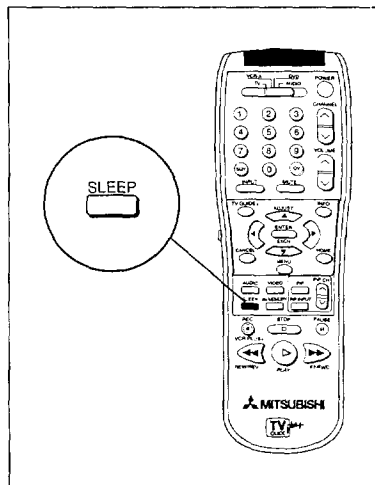

setting the sleep timer

- 1 Press the SLEEP button on the remote control. The sleep timer display will appear on the screen.
- 2 Select how long you want the TV to stay on by repeatedly pressing the SLEEP button. The time will decrease in 10 minute intervals each time you press the button.
- 3 When you reach the time you want, stop pressing the button. The sleep timer display will disappear after a few seconds.
- 4 To view the amount of time left in the sleep timer press the SLEEP button once. The on-screen display shows the amount of time remaining.

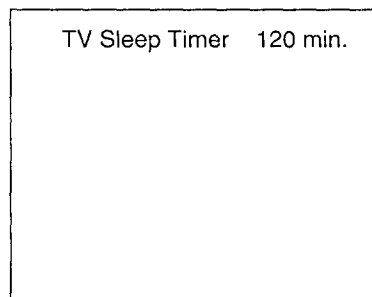

▷ **Important:** During the last minute before the TV turns off, "Sleep Timer 1 min." will flash in red to remind you that the sleep timer is set.

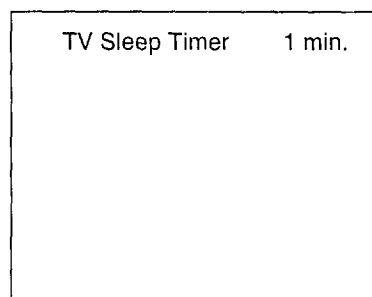

changing or canceling the sleep timer

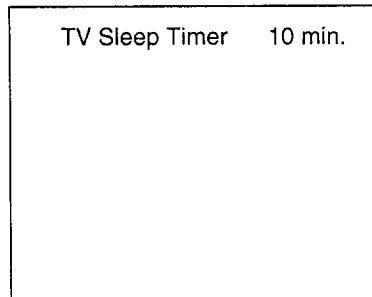

- ① Press the SLEEP button on the remote control. An on-screen display will indicate the amount of time remaining until the TV turns off.
- ② Repeatedly press the SLEEP button to change the remaining time or to cancel the sleep timer. The sleep timer is canceled when "-- --" appears instead of the remaining time.

◆ Using the Picture-in-Picture (PIP) Modes

One of the special features of the TV is the picture-in-picture (PIP) mode, which allows you to view two different sources at the same time. In this section you'll learn:

- **Activating the PIP image**
- **Selecting the source of the PIP image**
- **Changing channels while using the PIP modes**
- **Exchanging the picture of the PIP image and the main image**
- **Moving the PIP image**
- **Freezing the PIP image**

activating the PIP image

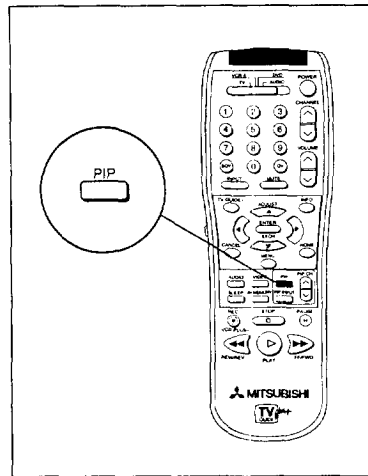

❶ Select the channel you want to view.

❷ Press the PIP button.

❸ A PIP image will appear in the corner of the screen.

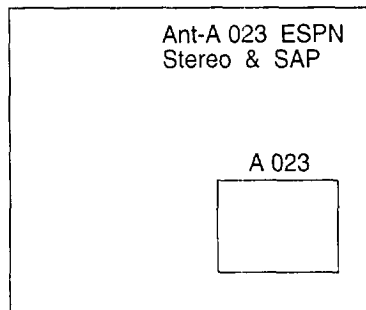

❹ Press PIP again within 10 seconds; the PIP image will reduce to a smaller size.

(If you wait longer than 10 seconds the PIP image will disappear when you press the PIP button.)

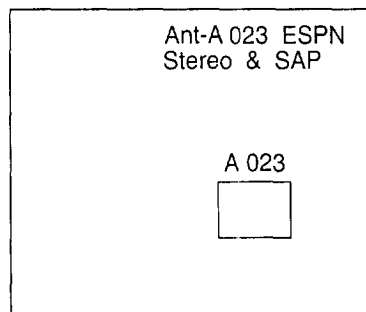

❺ Press the PIP button once again to cancel the PIP image.

- ▷ **Important:** When the main image is black and white, the PIP image will also appear in black and white.
- ▷ **Important:** If you move the PIP image and then turn it off, it will remain in its new position when you turn it on again.
- ▷ **Important:** Do not press the PIP button while you are at a channel that is not receiving broadcasts.

selecting the source of the PIP image

The Mitsubishi TV you have purchased has two-tuner PIP. If you have only an ANT-A input connected, you can view one program on the main picture and another channel from the same ANT input on the PIP display without the use of a second external tuner, such as a VCR.

▷ **Important:** If you have a cable box on ANT-A, you will not be able to have both the PIP and main pictures from ANT-A. The main picture must be ANT-B and the PIP picture ANT-A (cable box).

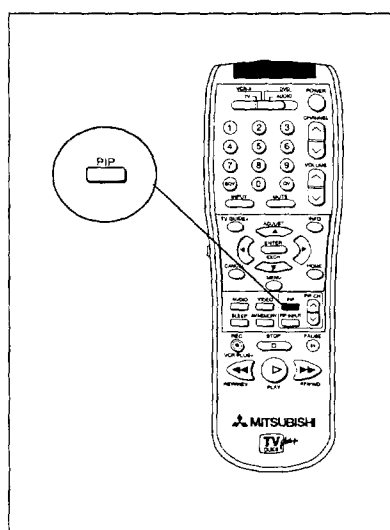

- 1 Turn the PIP image on by pressing the PIP button.
- 2 To select the PIP input, press the PIP INPUT button. Each time you press the button, the PIP input will select the next input from the inputs available:

- ANT-A, INPUT 1, INPUT 2 or INPUT 3
- You can select ANT-B in PIP, only when the main input is from INPUT 1, INPUT 2 or INPUT 3.

Each time you select a different input, an on-screen display will appear for about five seconds. The screen will display the name of the input selected.

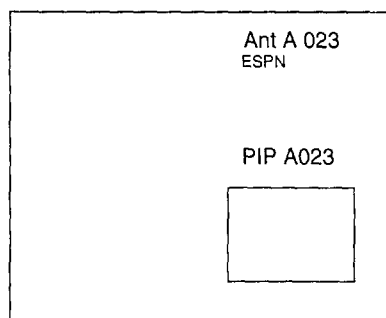

- 3 You can also select the PIP input source by first selecting the source in the main picture and then pressing the ENTER/EXCH button. Pressing this button with the PIP displayed exchanges the PIP picture for the main picture.

▷ **Important:** If you have a picture displayed from ANT-B on the main picture, and the PIP source from ANT-A, the ENTER/EXCH button will *not* exchange the main picture for the PIP picture.

changing channels while using the PIP modes

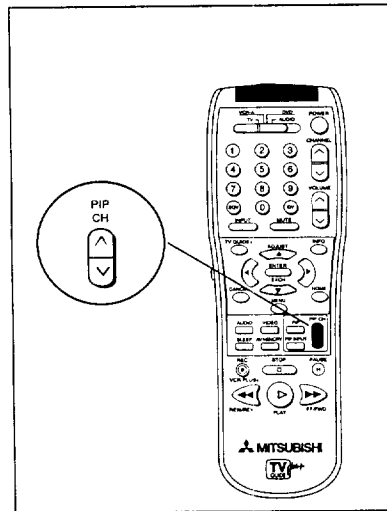

① Press the PIP channel up or down button (PIP CH) on the remote control to change the channel of the PIP image.

② Press the CHANNEL up or down button on the remote control to change the channel of the main image.

▷ **Important:** The PIP CH Buttons change the channel for the small PIP image *under two conditions:*

- When that image is a channel from ANT-A
- When the main picture is from an external input (INPUT-1, INPUT-2, or INPUT-3) and the PIP is from ANT-A or ANT-B

When the PIP image comes from another piece of equipment (e.g., your satellite receiver, cable box or VCR) the PIP CH buttons do not change the picture.

exchanging the picture of the PIP image and the main image

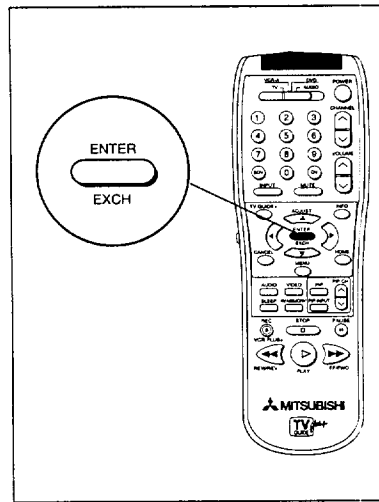

You may exchange the picture of the main (background) image and the PIP image by pressing the ENTER/EXCH button.

▷ Important:

If one picture is from ANT-A and the other is from ANT-B, nothing will happen when the ENTER/EXCH button is pressed.

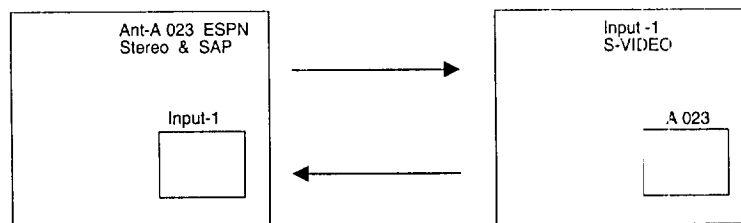

Moving the PIP image

Press the ADJUST buttons to move the PIP image.

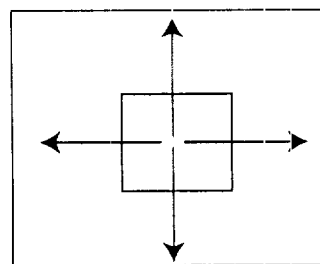
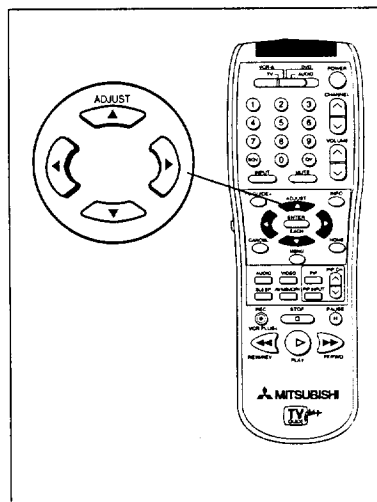

▷ **Important:** If you move the PIP image and then turn it off, it will appear in its last position when you turn it on again.

freezing the PIP image

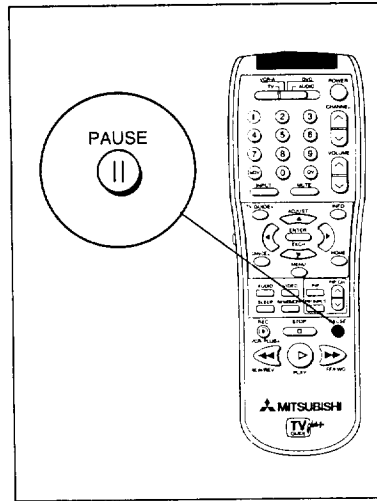

- 1 Press the PAUSE button to freeze the PIP image on the screen.
- 2 Press PAUSE again to return to a live picture.

▷ **Important:** If you press the pause button while viewing a picture without a PIP image, a PIP image will appear and be frozen.

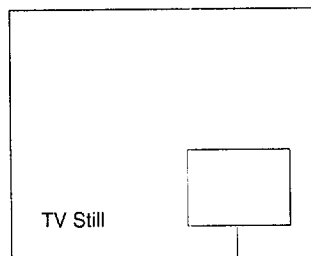

To remove the frozen picture, press the PIP button.

◆ Using the Active A/V Network Feature

This A/V Network is a special feature that makes it easier to use your television and other Mitsubishi A/V components together. When you connect the A/V Network, you can point the remote control at the television, and it will pass the remote control command to other components.

You will gain even more benefits if you have a Mitsubishi VCR equipped for the Active A/V Network. The Active A/V Network allows you to perform many of the commonly used features of your system at the press of just one button. This section explains the various features of the Active A/V Network.

before you begin



If you have installed TV GUIDE Plus+ on your TV, you can use the VCR Plus+ feature to control your VCR for recording.

- You must have connected an A/V Network cable from the Active A/V Network terminal of your TV to the "A/V Network IN" terminal of your VCR. See "TV+Mitsubishi Products that have A/V Network Terminals" in Chapter 2.
- You must have connected your VCR to INPUT-1 of your TV.
- You must have set your TV A/V Network setting to Active or Basic. See "Setting the A/V Network" in Chapter 3.
- Your VCR's remote control settings should be set to VCR-A.
- Your VCR video mute setting should be turned ON.

what the Active A/V Network does

The Active A/V Network makes it easier and faster to use the VCR Play command or display your VCR's menu.

- ▷ **Important:** When using the Active A/V Network, you should always point your remote control at your television.
- ▷ **Important:** If the TV is not receiving a signal on INPUT-1, it will automatically turn off in about one or two minutes. If you use a TV menu during this time, the TV will turn off in about five minutes after you stop using the menus.

using the PLAY button

When you press PLAY on the remote:

- Active A/V Network will turn your VCR on and begin playing the tape (if any).
- Active A/V Network will turn your TV on and switch it to INPUT-1.
- When you turn your TV off, your VCR will turn off, *unless* it is playing or recording.

displaying the VCR menu

When you set the remote to VCR A and then press MENU:

- Active A/V Network will turn on your VCR if it is off and display the VCR's menu.
- Active A/V Network will turn on your TV if it is off and switch it to INPUT-1.



Even though you're now familiar with the basic and advanced operations of the TV, you may occasionally encounter a problem. This chapter offers common answers to some of the most frequently asked questions of TV owners. We suggest that you consult this chart before contacting a Mitsubishi service representative.

Troubleshooting (cont.)

Problem	Possible Solution	For More Information
<ul style="list-style-type: none">• The remote control doesn't work.	<ul style="list-style-type: none">• Check that the batteries are installed correctly.• Check that the select switch is set to "TV".• Be sure that you are pointing the tip of the remote control toward the TV from a distance of no more than 20 feet.	<ul style="list-style-type: none">• See <i>Getting Ready to Use the Remote Control</i> in Chapter 1 for an explanation of how to install batteries in the remote control.• See <i>Remote Control Buttons and Functions</i> in Chapter 1, which explains where the select switch is located.• See <i>Getting Ready to Use the Remote Control</i> in Chapter 1, which contains pointers for using the remote control.
<ul style="list-style-type: none">• The TV takes several seconds to respond to button commands.	<ul style="list-style-type: none">• Use the ENTER/EXCH button to avoid delays.	<ul style="list-style-type: none">• See <i>Charging Channels</i> in Chapter 3, which explains the function of the ENTER/EXCH button.
<ul style="list-style-type: none">• You can't access a channel.	<ul style="list-style-type: none">• Be sure that the channel you want to view is programmed into memory.• Check that the TV is tuned to the correct input source (antenna) for that channel.	<ul style="list-style-type: none">• See <i>Memorizing Channels</i> in Chapter 3, which explains how to program channels into the TV's memory.• See <i>Selecting the Input Source</i> in Chapter 3, which explains how to change the input source.
<ul style="list-style-type: none">• On-screen displays appear each time you adjust a function.	<ul style="list-style-type: none">• This is part of the normal operation of the TV.	<ul style="list-style-type: none">• See <i>Screen Displays</i> in Chapter 4 for a full explanation of the on-screen displays.

Troubleshooting (cont.)

Problem	Possible Solutions	For More Information
<ul style="list-style-type: none"> There's no sound even when the volume is turned up. 	<ul style="list-style-type: none"> Check that the MUTE button isn't on. The TV's "Listen to:" setting may be set to "second audio program" (S.A.P.). Check that "Speaker" setting is set to "On." 	<ul style="list-style-type: none"> See <i>Remote Control Buttons and Functions</i> in Chapter 1, which explains the location and function of the MUTE button. See <i>Customizing AV Memory</i> in Chapter 3, which explains how to adjust the "Listen to:" setting. See <i>Customizing AV Memory</i> in Chapter 3, which explains how to adjust the "Speaker" setting.
<ul style="list-style-type: none"> You forget the code you used to set the parental lock. 	<ul style="list-style-type: none"> Use the alternate procedure that doesn't require the use of the code. 	<ul style="list-style-type: none"> See the Appendix, <i>Procedure for Bypassing the Parental Lock</i>.
<ul style="list-style-type: none"> You can't program the TV to turn on automatically. 	<ul style="list-style-type: none"> The TV may be locked. 	<ul style="list-style-type: none"> See <i>Using the Parental Lock</i> within <i>Using the Advanced Features</i> in Chapter 3.
<ul style="list-style-type: none"> The sound doesn't match the image on screen. 	<ul style="list-style-type: none"> The TV's "Listen to:" setting may be set to "second audio program" (S.A.P.). 	<ul style="list-style-type: none"> See <i>Customizing AV Memory</i> in Chapter 3, which explains how to adjust the "Listen to:" setting.
<ul style="list-style-type: none"> There is a large black or gray rectangle on the screen. 	<ul style="list-style-type: none"> The TV has been set to "text" mode, but there is no text information being broadcast. 	<ul style="list-style-type: none"> See <i>Using the Closed Caption Decoder</i> in the <i>Getting Started</i> section of Chapter 3, or press the HOME button to make the rectangle disappear.
<ul style="list-style-type: none"> You cannot see a picture when you play a tape in the VCR. 	<ul style="list-style-type: none"> If you connected your VCR with A/V cables, use the INPUT button to select the input source (Input 1, 2, or 3) that the VCR is connected to. 	<ul style="list-style-type: none"> See <i>Selecting the Input Source</i> for an explanation about changing the input.

Troubleshooting (cont.)

Problem	Possible Solution	For More Information
<ul style="list-style-type: none">• Antenna-B does not appear as a PIP source.	<ul style="list-style-type: none">• Antenna B cannot appear as a PIP source when antenna A is the main picture.	<ul style="list-style-type: none">• See <i>Using the Picture-in-Picture (PIP) Modes</i> in Chapter 4.

Caution and care

► **Warning:** Don't leave stationary images on-screen for more than 10 minutes.

These images can scar the picture tube, causing permanent damage to the TV. Some examples of stationary images are:

- stock-market reports
- station logos (especially bright ones)
- video game displays
- shopping channel displays
- the television's own on-screen displays

▷ **Important:** If you plan to place speakers next to the TV, make sure they are magnetically shielded. Ordinary speakers will cause distortion in the picture due to their strong magnets. This distortion, however, will not harm the picture tubes.

For maximum enjoyment and safe operation of your Mitsubishi TV, please read *IMPORTANT SAFEGUARDS*, pages 3 and 4 of your Owners Guide, very carefully and apply them properly.

Cleaning

Normally, light dusting with a non-scratching duster will keep your TV clean.

If you want to wipe down your TV, turn it off and unplug it. Then, wipe it gently with a soft cloth slightly moistened with water. You can add a few drops of mild liquid detergent to the water for oily dirt.

DO NOT allow liquid to enter the TV through the ventilation slots.

DO NOT use strong or abrasive cleaners.

DO NOT use spray liquids or cleaners directly on the TV's surface.

DO NOT scrub or rub the TV harshly. Wipe gently.

calling for service

If you are unable to correct a problem with your TV, consult your Mitsubishi dealer or Mitsubishi Authorized Warranty Service Center.

DO NOT adjust any controls not described in this owner's guide.

DO NOT remove the protective back cover of this unit.

If you see one of the following displays on your screen, you should not change any settings. These are special displays used by the factory.

If any of these settings are changed your warranty may be void.

NOTE: "Firmware Versions" are included for reference only and will vary from those shown below.

If these displays appear, make sure that all of the on/off settings are the same as the illustrations above and then turn the TV off. If any of the settings are different from the illustrations below, turn the TV off and consult your Mitsubishi dealer or Mitsubishi Authorized Warranty Service Center.

Initial	3dia	: On
E2RESET	Auto clock	: On
Hotel	Guide Plus	: On
Power Res	: Off	
Ant	: 2	
Input	: 3	
When mute	: On	
Firmware Version: M37270-XXXSP ...		
M38123-XXXSP ...		
LC86P4164 ...		

Initial		
Hotel	: Off	
Power Res	: Off	
Ant	: 2	
Input	: 3	
When mute	: On	
Firmware Version: M37270-XXXSP ...		
M38123-XXXSP ...		
LC86P4164 ...		

For further assistance, please call 800-332-2119



Procedure for Bypassing the Parental Lock

Cut along dotted line and file after reading.

After you set the lock, you will need the secret code in order to:

- view a locked channel,
- view the locked TV, or
- cancel the lock.

If you forget the code, you can view the locked TV without entering the code. To do this, simply press the buttons on your remote labeled “QV” and “9” at the same time whenever your secret code is requested.

▷ **Important:** Unlocking with this procedure is only temporary. To cancel the lock completely, follow the procedure below:

- ① Turn on your TV. If the TV requests your secret code, press the “QV” button and the “9” button on the remote control at the same time.
- ② Press the MENU button to view the main menu. Use the ADJUST button to select “Advanced Features”. Press ENTER/EXCH.
- ③ Use the ADJUST button to select “Use Parental Lock”. Press ENTER/EXCH.
- ④ Press the “QV” button and the “9” button on the remote control at the same time, instead of entering the code.
- ⑤ If you were using “Lock the TV”, the lock must be turned off. Using the ADJUST up/down buttons, select the “Off” setting.
- ⑥ If you were using “Lock the Channel,” use the ADJUST up/down buttons to place the cursor next to the channel whose lock you want to turn off. Press ENTER/EXCH.
- ⑦ Press the CANCEL button to unlock that channel or use the ADJUST up/down buttons to change the channel to a new one.
- ⑧ Press the MENU button to return to the “Advanced Features” menu.

▷ **Important:** You must use the remote control included with this TV. You cannot use a remote control from another Mitsubishi component and you cannot use “Universal” remotes from other manufacturers.

A		H
A/V Components		Hall Mode 75
Using the remote with 41		Home Button 18
A/V Memory Positions		I
Adjusting the picture 68		Important Safeguards 3
Selecting 68		Information Button 17
A/V Memory button 18		Input Button (Front Panel) 13
A/V Network		Input Button (Remote) 17
Description 59, 97		Inputs
Using 59, 97		Naming 63
A/V Network Terminals 21		Selecting the input source 48
connecting 37		Instant Info 71
A/V System		IR Emitter 7, 21, 24, 27, 30
Adjusting the convergence 60		IR/G Link 21
Adjusting the picture 70		IRIS™ 6, 13, 70
Adjusting the sound 75		L
Connecting audio		Language, Selecting menu 67
components 36		Level Sound 6, 76
Memory settings 68		Light Button 17
Active A/V Network Terminal... 21		Listen-To Function 75
Active AV Network, Using 97		Locking Channels 83
Adjust Buttons 17		Using the parental lock 81
Advanced Features, Using 79		Locking Your TV 82
ANT-A Terminal 20		Bypassing the parental lock 105
ANT-B Terminal 20		M
Antennas		Memorizing Channels 57
Antenna terminals 20		Menu
Connecting UHF/VHF 26		Selecting menu language 67
Audio Controls 18		Selecting menu type 61
Audio Functions		Menu Button 13, 18
Adjusting 75		Monitor Out 76
Balance 75		Mono 75
Bass 75		Mute Button 17
Level Sound 76		N
Listen to 75		Number Buttons (0-9) 17
Monitor Out 76		O
Speaker 76		On-Screen Displays
Surround 75		Understanding 88
Treble 75		On-Screen Menus, Using 53
Audio Input Terminals 13, 21		Operating Your TV 39
Audio Output Terminals 21		P
B		Parental Lock
Back Panel 20		Bypassing 105
Background 71		Canceling or Changing 84
Batteries, Installing 14		Locking the TV 82
Balance 75		Using 81
Basic Connections 22		
Bass 75		
Brightness 70		
C		
Cable Loop Out Terminal 20		
	Cable TV	
	Using remote with 43	
	Cancel Button 13, 18	
	Channel Controls 13, 17	
	Channels	
	Adding/Deleting 58	
	Changing 49	
	Locking 82	
	Naming 64	
	Memorizing 57	
	Using QuickView™ 51	
	Using SuperQuickView™ 52	
	Cleaning your TV 103	
	Clock, Setting 54	
	Closed Caption Decoder	
	Adjusting 74	
	Closed Captioning, Using 73	
	Color Temperature 70	
	Color 70	
	Connections	
	TV+antenna or cable without	
	a cable box 23	
	TV+cable with a cable box... 24	
	TV+Mitsubishi products with	
	A/V network terminals 37	
	TV+separate UHF and VHF	
	antennas 26	
	TV+stereo audio system 36	
	TV+VCR+cable	
	with a cable box 30	
	TV+VCR+antenna or cable	
	without a cable box 27	
	TV+VCR+cable with a	
	cable box 27	
	Contrast 70	
	Control Panels 12	
	Controls 12-18	
	Audio 18	
	Channel 13, 17	
	Picture-in-picture (PIP) 18	
	Remote control 16	
	Turning your TV on/off 47	
	Video 18	
	Volume 13, 17	
	Convergence 60	
	E	
	Enter/Exchange Button 13, 17	
	Español 67	
	Extended Data Services 88	
	F	
	Fixed Monitor Out 76	



MITSUBISHI CONSUMER ELECTRONICS AMERICA, INC.

6100 Atlantic Blvd.

Norcross, GA 30071-1305

© 1997 Mitsubishi Consumer Electronics America, Inc.

871D225A10

Printed in U.S.A.