

 MITSUBISHI

**CS-31303**  
**CS-35303**  
**CS-35313**

TV

Owner's  
Guide

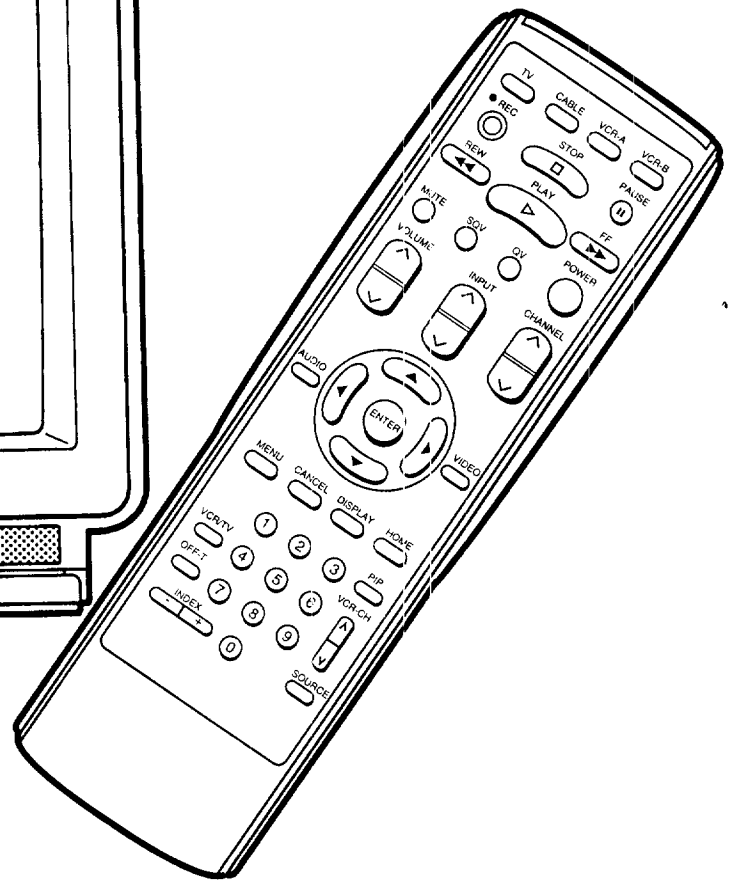
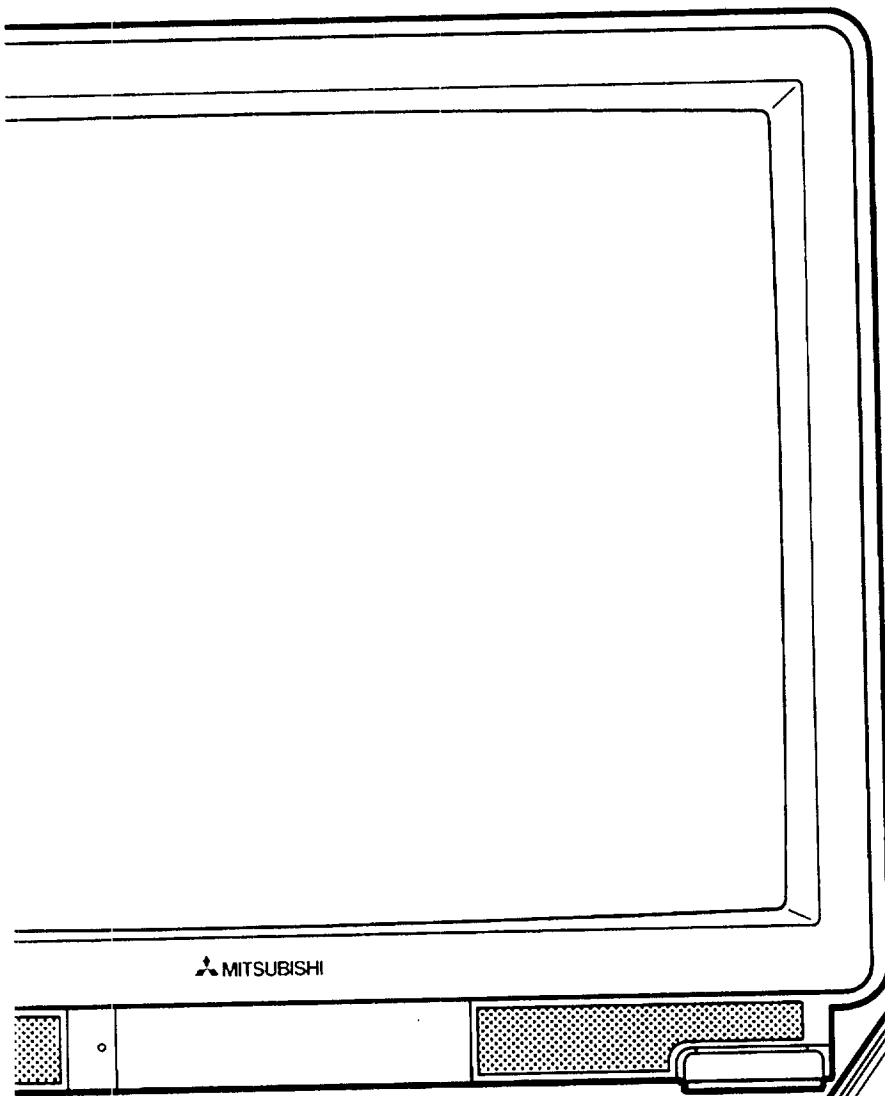

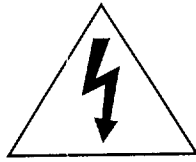

## CAUTION

RISK OF ELECTRIC SHOCK  
DO NOT OPEN



**CAUTION:** TO REDUCE THE RISK OF ELECTRIC SHOCK,  
DO NOT REMOVE COVER (OR BACK)  
NO USER-SERVICEABLE PARTS INSIDE  
REFER SERVICING TO QUALIFIED SERVICE PERSONNEL.

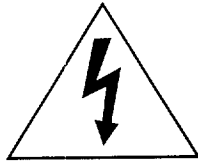

The lightning flash with arrowhead symbol, within an equilateral triangle, is intended to alert the user to the presence of uninsulated "dangerous voltage" within the product's enclosure that may be of sufficient magnitude to constitute a risk of electric shock.



The exclamation point within an equilateral triangle is intended to alert the user to the presence of important operating and maintenance (servicing) instructions in the literature accompanying the appliance.

### **WARNING:**

TO PREVENT FIRE OR SHOCK HAZARD, DO NOT EXPOSE THIS APPLIANCE TO RAIN OR MOISTURE.

### **CAUTION:**

TO PREVENT ELECTRIC SHOCK HAZARD, DO NOT USE THIS UNIT'S (POLARIZED) PLUG WITH AN EXTENSION CORD, RECEPTACLE OR OTHER OUTLET UNLESS THE BLADES CAN BE FULLY INSERTED TO PREVENT BLADE EXPOSURE.

### **NOTE TO CATV SYSTEM INSTALLER:**

THIS REMINDER IS PROVIDED TO CALL THE CATV SYSTEM INSTALLER'S ATTENTION TO ARTICLE 820-40 OF THE NEC THAT PROVIDES GUIDELINES FOR PROPER GROUNDING AND, IN PARTICULAR, SPECIFIES THAT THE CABLE GROUND SHALL BE CONNECTED TO THE GROUNDING SYSTEM OF THE BUILDING, AS CLOSE TO THE POINT OF CABLE ENTRY AS PRACTICAL.



# Table of Contents

<b>Important Safeguards</b> .....	3
<b>Preface: Welcome to Mitsubishi</b> .....	9
Summary of Special Features .....	10
Unpacking Your TV .....	11
What you'll find .....	11
A few suggestions .....	11
What's in Each Chapter .....	12
Some Conventions Used in this Guide .....	13
<b>Chapter 1: Getting to Know Your TV</b> .....	15
Overview of the Control Panel .....	16
Overview of the Remote Control .....	18
Getting ready to use the remote control .....	18
Remote control buttons and functions .....	20
<b>Chapter 2: Connecting Your TV</b> .....	25
Overview of the Back Panel .....	26
Basic Connections .....	27
TV+antenna or cable without a decoder box .....	28
TV+cable with a decoder box .....	29
TV+separate UHF and VHF antennas .....	30
TV+VCR+antenna or cable without a decoder box .....	31
TV+VCR+cable with a decoder box .....	34
TV+audio system .....	37
<b>Chapter 3: Operating Your TV</b> .....	39
Getting Started .....	40
Adjusting the color purity .....	41
Using the remote control .....	42
Turning the TV on/off .....	46
Selecting the input source .....	47

---

Getting Started (cont.)	
Changing channels .....	48
Understanding the on-screen menus .....	51
Setting the clock .....	52
Memorizing channels .....	54
Adding and deleting channels .....	55
Renaming the inputs .....	56
Selecting language .....	57
Using video mute .....	58
Using the power restore feature .....	59
Using the advanced PIP functions .....	60
Adjusting the sound .....	61
Adjusting the picture .....	63
Using the closed caption decoder .....	64
Using the Advanced Features .....	65
Setting the timer .....	66
Using the parental lock .....	67
Using the Super Quick View tuning .....	69
<b>Chapter 4: Using the Special Features .....</b>	<b>71</b>
Understanding the On-Screen Displays .....	72
Using the Off-Timer .....	73
Setting the off-timer .....	74
Changing or canceling the off-timer .....	75
Using the Picture-in-Picture (PIP) Mode .....	76
Selecting the PIP image .....	77
Selecting the source .....	78
Selecting the channel .....	78
Exchanging the PIP image .....	79
Moving the PIP image .....	79
Freezing the PIP image .....	80
Using the Snap-shot feature .....	81
Using the Replay feature .....	82
<b>Chapter 5: Troubleshooting.....</b>	<b>83</b>
Caution and Care .....	86
Calling for Service .....	87
<b>Appendix: Automatic Procedure for the Parental Lock.....</b>	<b>89</b>
<b>Index .....</b>	<b>91</b>
<b>Warranty .....</b>	<b>93</b>

# IMPORTANT SAFEGUARDS

---

**PLEASE READ ALL THESE INSTRUCTIONS REGARDING YOUR TELEVISION SET AND RETAIN FOR FUTURE REFERENCES. FOLLOW ALL WARNINGS AND INSTRUCTIONS MARKED ON THE TV RECEIVER.**

1. **Read Instructions**  
All the safety and operating instructions should be read before the appliance is operated.
2. **Retain Instructions**  
The safety and operating instructions should be retained for future reference.
3. **Heed Warnings**  
All warnings on the appliance and in the operating instructions should be adhered to.
4. **Follow Instructions**  
All operating and use instructions should be followed.
5. **Cleaning**  
Unplug this TV receiver from the wall outlet before cleaning. Do not use liquid or aerosol cleaners. Use a damp cloth for cleaning. Do not use chemicals on your TV's screen.
6. **Attachment and Equipment**  
Never add any attachments and/or equipment without approval of the manufacturer as such additions may result in the risk of fire, electric shock or other personal injury.
7. **Water and Moisture**  
Do not use this TV receiver where contact with or immersion in water is a possibility. Do not use near: bath tubs, wash bowls, kitchen sinks, laundry tubs, or swimming pools, etc.

► **Warning:**

Don't leave stationary images, such as those generated from stock market reports or video games, on-screen for more than 10 minutes. Still patterns can scar the TV causing permanent damage to the picture tube.

---

8. Accessories

Do not place this TV receiver on an unstable cart, stand, tripod, bracket, or table. The TV receiver may fall, causing serious injury to a child or adult, and serious damage to the appliance. Use only with a cart, stand, tripod bracket, or table recommended by the manufacturer, or sold with the TV receiver. Any mounting of the appliance should follow the manufacturer's instructions, and should use a mounting accessory recommended by the manufacturer.

An appliance and cart combination should be moved with care. Quick stops, excessive force, and uneven surfaces may cause the appliance and cart combination to overturn.



S 3126 A

9. Ventilation

Slots and openings in the cabinet are provided for ventilation and to ensure reliable operation of the TV receiver and to protect it from overheating. Do not block these openings or allow them to be blocked by placing the TV receiver on a bed, sofa, rug, or other similar surface. Nor should it be placed over a radiator or heat register. If the TV receiver is to be placed in a rack or bookcase, ensure that there is adequate ventilation and that the manufacturer's instructions have been adhered to.

- 
10. **Power Sources**

This TV receiver should be operated only from the type of power source indicated on the marking label. If you are not sure of the type of power supply to your home, consult your appliance dealer or local power company.
  11. **Grounding or Polarization**

For your safety, this TV receiver is equipped with a polarized alternating current line plug having one blade wider than the other. This plug will fit into the power outlet only one way. If you are unable to insert the plug fully into the outlet. Try reversing the plug. If the plug should still fail to fit, contact your electrician to replace your obsolete outlet. Do not defeat the safety purpose of polarized plug.
  12. **Power-Cord Protection**

Power-supply cords should be routed so that they are not likely to be walked on or pinched by items placed upon or against them, paying particular attention to cords at plugs, convenience receptacles, and the point where they exit from the appliance.
  13. **Lightning**

For added protection for this TV receiver during a lightning storm, or when it is left unattended and unused for long periods of time, unplug it from the wall outlet and disconnect the antenna or cable system. This will prevent damage to the video product due to lightning and power-line surges.
  14. **Power Lines**

An outside antenna system should not be located in the vicinity of overhead power lines or other electric light or power circuits, or where it can fall into such power lines or circuits. When installing an outside antenna system, extreme care should be taken to keep from touching such power lines or circuits as contact with them might be fatal.

15. **Overloading**  
Do not overload wall outlet and extension cords as this can result in a risk of fire or electric shock.
16. **Object and Liquid Entry**  
Never push objects of any kind into this TV receiver through openings as they may touch dangerous voltage points or short-out parts that could result in a fire or electric shock. Never spill liquid of any kind on the TV receiver.
17. **Outdoor Antenna Grounding**  
If an outside antenna or cable system is connected to the TV receiver, be sure the antenna or cable system is grounded so as to provide some protection against voltage surges and built-up static charges.

Section 810 of the National Electrical Code, ANSI/NFPA No.70-1984, provides information with respect to proper grounding of the mast and supporting structure, grounding of the lead-in wire to an antenna discharge unit, size of grounding conductors, location of antenna-discharge unit, connection to grounding electrodes, and requirements for the grounding electrode.

**EXAMPLE OF ANTENNA GROUNDING  
AS PER NATIONAL ELECTRICAL CODE**

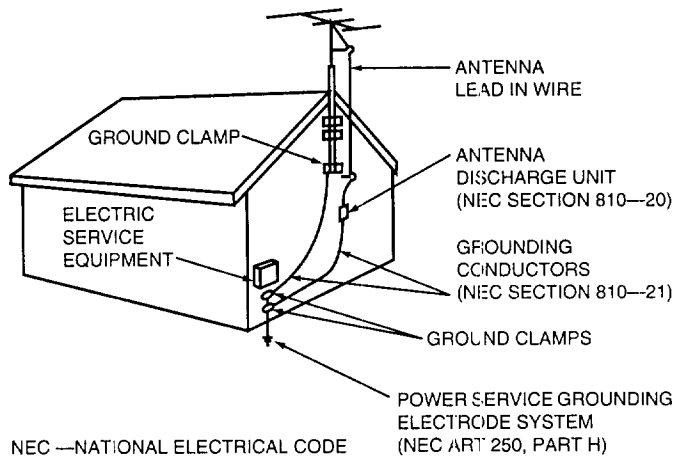



- 
18. Servicing  
Do not attempt to service this TV receiver yourself as opening or removing covers may expose you to dangerous voltage or other hazards. Refer all servicing to qualified service personnel.
19. Damage Requiring Service  
Unplug this TV receiver from the wall outlet and refer servicing to qualified service personnel under the following conditions :
- (a) When the power-supply cord or plug is damaged.
  - (b) If liquid has been spilled, or objects have fallen into the TV receiver.
  - (c) If the TV receiver has been exposed to rain or water.
  - (d) If the TV receiver does not operate normally by following the operating instructions. Adjust only those controls that are covered by the operating instructions as an improper adjustment of other controls may result in damage and will often require extensive work by a qualified technician to restore the TV receiver to its normal operation.
  - (e) If the TV receiver has been dropped or the cabinet has been damaged.
  - (f) When the TV receiver exhibits a distinct change in performance - this indicates a need for service.
20. Replacement Parts  
When replacement parts are required, be sure the service technician has used replacement parts specified by the manufacturer or have the same characteristics as the original part. Unauthorized substitutions may result in fire, electric shock or other hazards.
21. Safety Check  
Upon completion of any service or repairs to this TV receiver ask the service technician to perform safety checks to determine that the TV receiver is in a safe operating condition.



## PREFACE

---

# Welcome to Mitsubishi

Congratulations on your purchase of a Mitsubishi TV. Your TV is designed for superb viewing pleasure as well as continued reliability.

To familiarize you with your TV and owner's guide, we suggest that you read through the preface, which provides the following important information:

- ◆ **Summary of Special Features**
- ◆ **Unpacking Your TV**
- ◆ **What's in Each Chapter**
- ◆ **Some Conventions Used in This Guide**

Mitsubishi has strived to create your TV so that it will bring you years of viewing enjoyment. Similarly, your owner's guide is designed with a "user friendly" philosophy that will help you take advantage of all of your equipment's features.

Once again, thank you for selecting our product and welcome to Mitsubishi!



## ◆ Summary of Special Features

---

Your top rated Mitsubishi TV delivers:

- **181-Channel Capacity** --- programs up to 181 channels, ensuring your continued viewing pleasure as cable services continue to expand.
- **Two-Speaker Sound System** --- a special, speaker system that produces clear, stereo sound. The CS-35303 and the CS-35313 have a four-speaker system.
- **Expanded Sound Capability** --- allows you to connect the TV to an external audio system for enhanced listening pleasure.

In addition to the standard features found on most advanced TVs, Mitsubishi is proud to offer the following distinctive features:

- **Remote Control with TV/VCR/CABLE Function** --- uses a single remote control transmitter for the television, certain Mitsubishi VCRs, and also some VCRs and cable boxes of other manufacturers.
- **On-Screen Displays** --- appear whenever you adjust your TV, showing you the status of your TV's various functions.
- **On-Screen Menu** --- simplifies the television's features with easy to follow instructions.
- **Closed Caption Decoder** --- supplies you with text information along with the regular broadcasts.
- **Television Data Services** --- (also known as "TVDS,") allows broadcasters to supply you with the time of day, channel information, and program information. You can display this information on-screen.
- **Picture-in-Picture Mode** --- allows you to view two different sources at the same time.

Each of these features will be explained in more detail in Chapter 3, "Operating Your TV," and Chapter 4, "Using the Special Features."

## ◆ Unpacking Your TV

---

### What you will find

As you unpack your new TV, please check to be sure that along with the TV, the following items are included:

- an owner's guide and a warranty,
- a registration card,
- a remote control transmitter, and
- a set of two AA size batteries for the remote control.

### A few suggestions

Before you hook up your new TV, please take a few minutes to:

- ❶ Complete the registration card. The registration card asks for the TV's serial number, which you'll find on the back of the unit.
- ❷ Keep the box and packing materials for future use.
- ❸ File your sales receipt.
- ❹ Place the TV on a stable surface with sufficient lighting to do the hook-up.

## ◆ What's in Each Chapter

---

Here's what you will find in this owner's guide:

Chapter 1, "Getting to Know Your TV," introduces you to the location and functions of the buttons and controls of your TV.

Chapter 2, "Connecting Your TV," explains how to connect a VCR, antenna, decoder and other equipment to your TV.

Chapter 3, "Operating Your TV," provides the step-by-step instructions you need in order to use your TV.

Chapter 4, "Using the Special Features," explains how to use some of the special features of the TV.

Chapter 5, "Troubleshooting," summarizes the problems you may have along with the suggestions for solving these problems.

The appendix explains a procedure for bypassing the parental lock.

You'll also find a detailed index at the back of the book.

## ◆ Some Conventions Used in this Guide

Mitsubishi has gone to great effort to provide users with an easy-to-follow, useful owner's guide. Different types of information is treated in different ways.

Users should read information labelled important and information which is boxed and labelled warning. The owner's guide uses these terms sparingly, and all information highlighted in this manner should be read carefully.

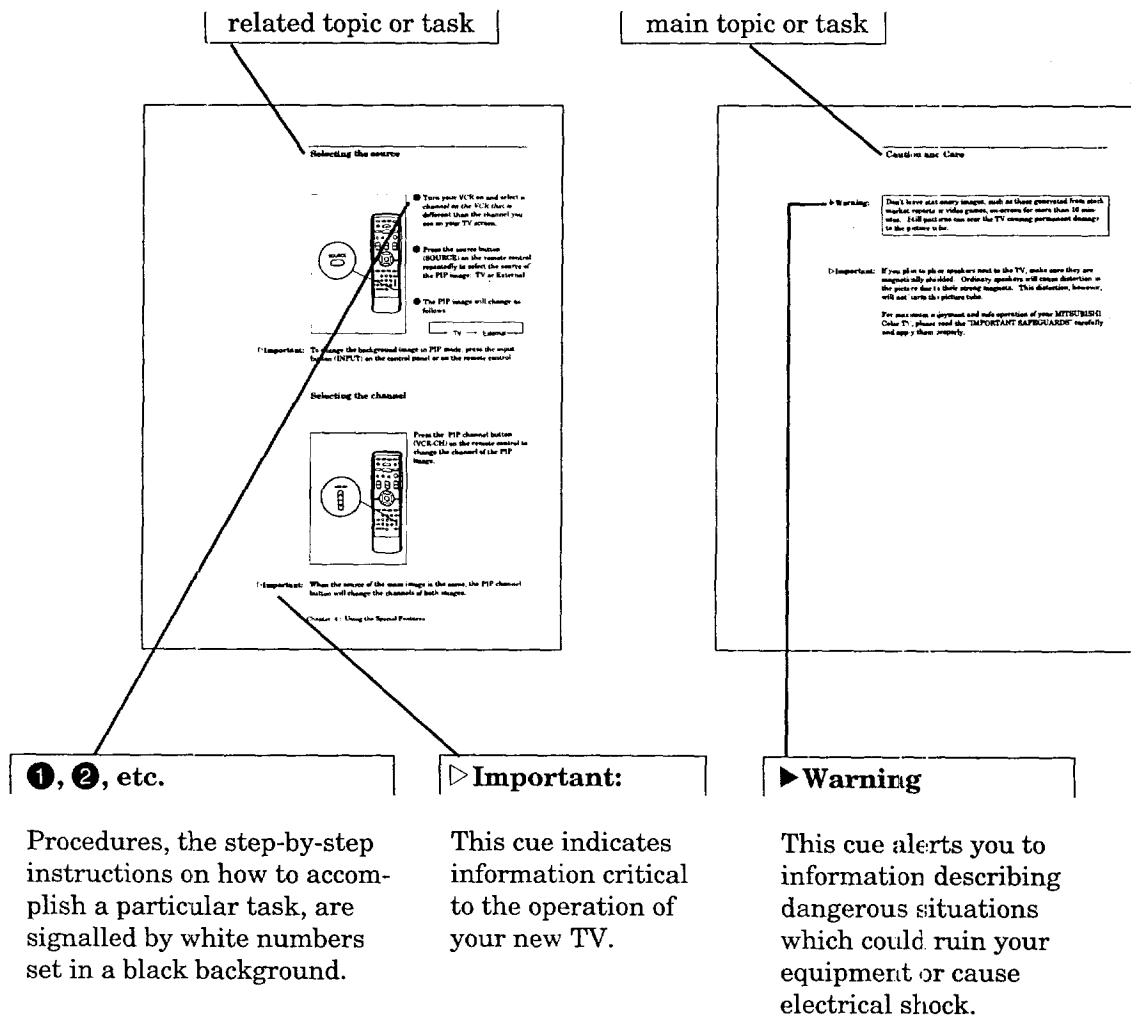







# Getting to Know Your TV

Now that you've unpacked your TV, read through the safety information, and glanced at the overview explaining how this owner's guide is organized, it's time to become familiar with the buttons and controls you'll be using when you operate the TV. This chapter will introduce the range of options available by using the buttons on the control panel of the TV or the remote control. It also offers some general guidelines for using the remote control.

Most functions can be controlled by using either the control panel or the remote control, but certain specialized functions require the use of one or the other. This chapter, which will familiarize you with the full range of button functions, contains the following sections:

- ◆ **Overview of the Control Panel**
- ◆ **Overview of the Remote Control**

## ◆ Overview of the Control Panel

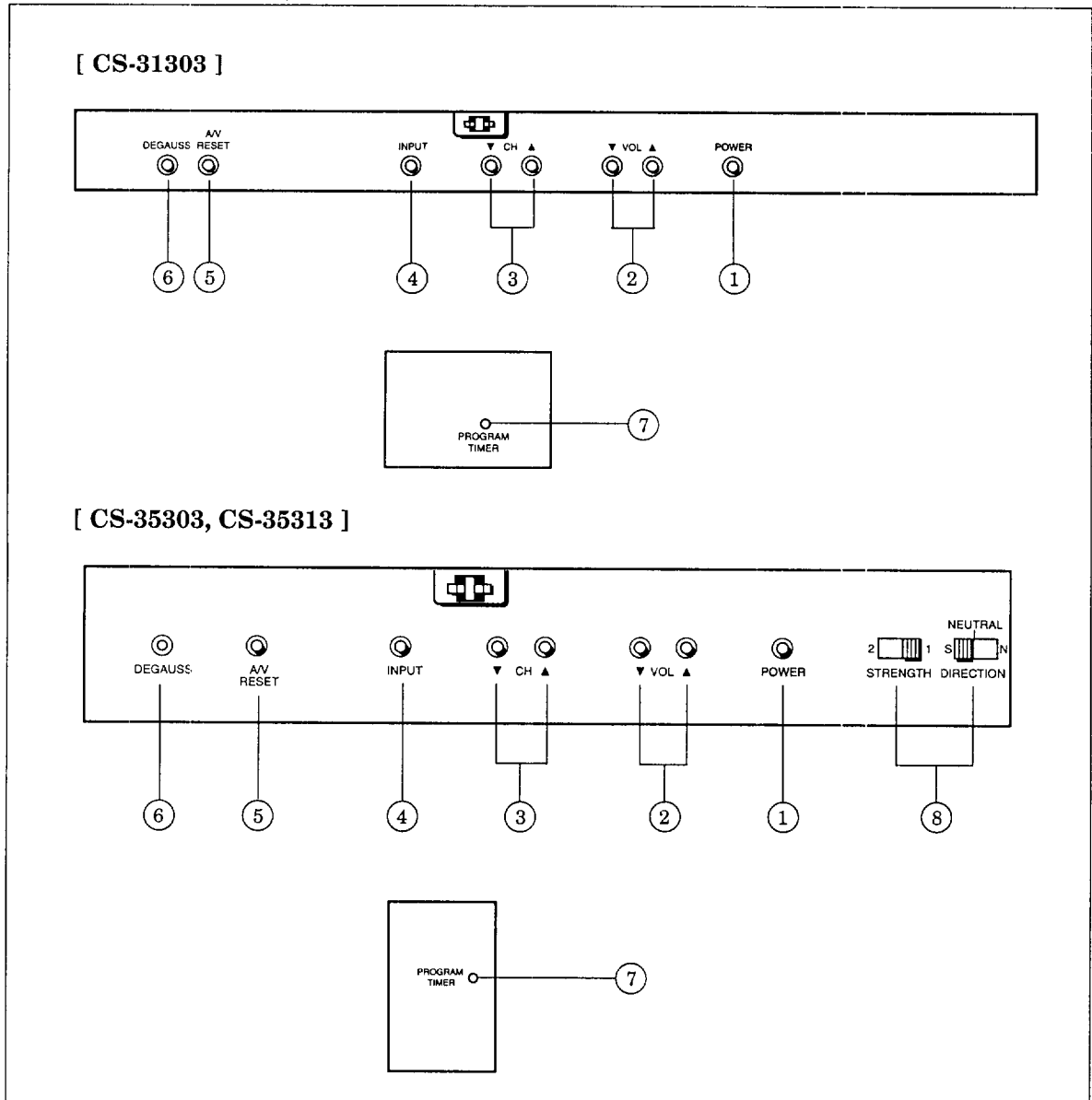

① **power button (POWER)**  
Use to turn the TV on or off.

② **volume controls (VOL)**  
Press the ▲ button to turn up the volume and the ▼ button to turn down the volume.

---

③ **channel controls (CH)**

Use the ▲ button to switch to a channel with a higher number and the ▼ button to switch to a channel with a lower number.

④ **input button (INPUT)**

Use to select the input source to be viewed:

- TV, or
- External.

⑤ **A/V reset button (A/V RESET)**

Press to reset all audio and video functions to their normal level or settings except for volume, reception mode (Stereo/SAP/Mono), speaker (on/off), and closed captioning.

⑥ **degauss button (DEGAUSS)**

Use this button to correct color impurity.

⑦ **program timer indicator (PROGRAM-TIMER)**

Lights up when the TV is programmed to turn on at a particular time.

⑧ **color purity adjustment switches (only for CS-35303, CS-35313)**

Set to the suitable position. (Please see page 41.)

## ◆ Overview of the Remote Control

---

### Getting ready to use the remote control

#### installing the batteries

- ❶ Take the box containing two AA size batteries from the packing bag.
- ❷ Remove the back cover of the remote control by pushing in the direction of the arrow.
- ❸ Load the batteries as indicated in the illustration, making sure that they are positioned correctly (+ to +, and - to -).
- ❹ Replace the back cover of the remote control.

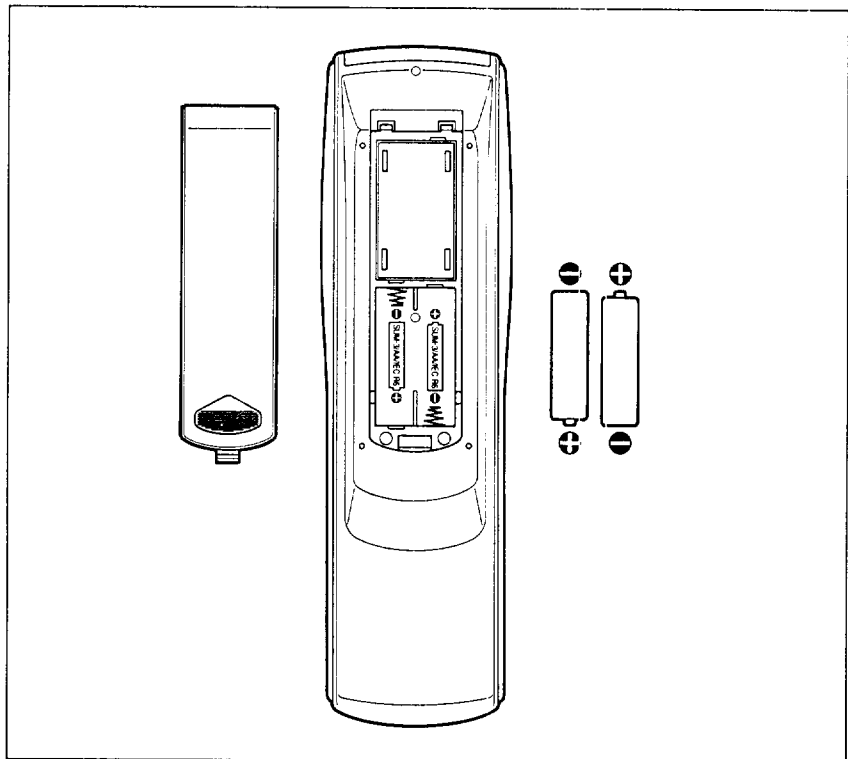

For best results, use Duracell AA (MN1500) batteries.

---

### **some dos and don'ts**

To ensure that your remote control will continue working properly, follow these guidelines:

- Don't press two or more buttons at the same time.
- Don't allow the remote control to get wet or become heated.
- Avoid dropping the remote control on a hard surface.
- When cleaning the remote control, don't use any harsh chemicals. Use only a soft, slightly moistened cloth.

### **general instructions**

When using the remote control to operate the TV, VCR or cable box, follow these procedures:

- ❶ Be within 20 feet of the desired equipment.
- ❷ Point the top of the remote control toward the equipment.
- ❸ Press the appropriate button or groups of buttons.

### **guidelines for using batteries**

- Don't use a new battery with an old one.
- Don't heat, take apart, or throw batteries into a fire.

The following section explains more about the range of options available by using the remote control.

## Remote control buttons and functions

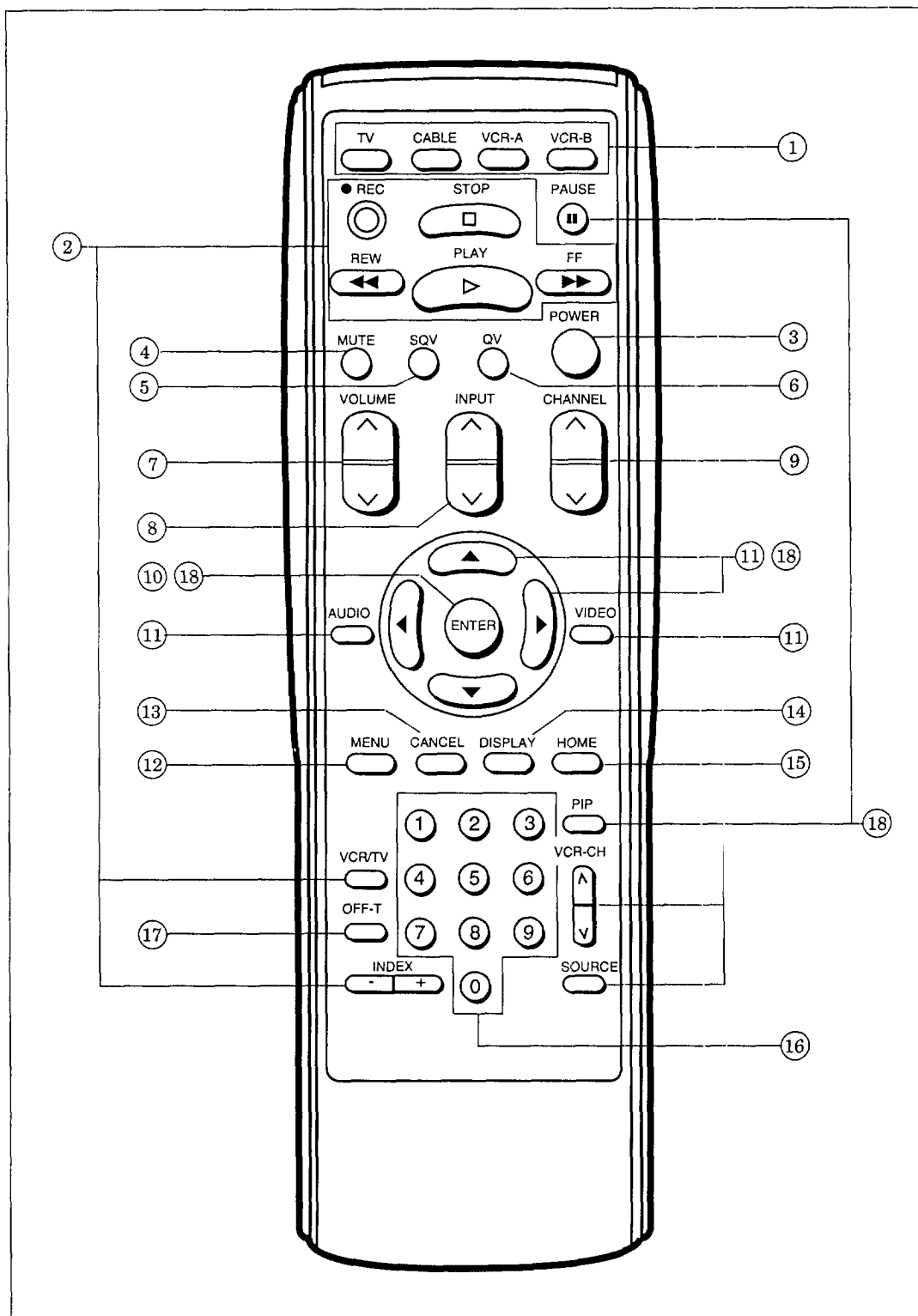

- 
- ① **select buttons**  
Use these buttons to select the component you wish to operate: the TV, an audio component (in CABLE layer), VCR-A or VCR-B. These are also used to set up your remote control for your particular brand of VCR.
  - ② **VCR buttons**  
These buttons can be used to control VCRs. These are pre-programmed to operate select Mitsubishi components.
  - ③ **power button (POWER)**  
Use to turn the TV on or off.
  - ④ **mute control (MUTE)**  
Use to turn the sound off completely or restore it to its original volume.
  - ⑤ **super quick view button (SQV)**  
Press to view channels you have programmed into the super quick view memory.
  - ⑥ **quick view button (QV)**  
Press to switch to the channel you have stored into the quick view memory.
  - ⑦ **volume control (VOLUME)**  
Press the top part of the button to turn up the volume; press the bottom part of the button to turn down the volume.
  - ⑧ **input button (INPUT)**  
Use to select the input source you wish to watch:
    - TV, or
    - External.
  - ⑨ **channel control (CHANNEL)**  
Press the top part of the button to change to a channel with a higher number; press the bottom part to change to a channel with a lower number.
  - ⑩ **enter button (ENTER)**  
May be used after selecting a channel number or an item from the on-screen menu system. Also use with the PIP function.
  - ⑪ **audio and video controls**  
These buttons are used in pairs to adjust features of the image or sound (other than volume) with a two-step process: using one of the audio or video buttons to select a function, and then using the adjust up/down button or right/left button.
    - **audio function button (AUDIO)**---Use to select one of the following audio functions:
      - stereo/SAP/mono,
      - bass,
      - treble,

---

- balance,
- surround off/simulate/hall, or
- speaker on/off.

- **video function button (VIDEO)**---Use to select one of the following video functions:
  - tint,
  - color,
  - contrast,
  - brightness,
  - sharpness,
  - color temperature low/middle/high, or
  - closed captioning.
- **adjust up/down buttons, right/left buttons**---After selecting the audio or video function, use either the up(right) or the down(left) button to adjust the function you've selected. These buttons can be used to:
  - turn the function on or off (e.g., speaker),
  - increase or decrease the function (e.g., color),
  - shift from one end of a scale to the other (e.g., balance), or
  - select a position (e.g., stereo).

You will also use the adjust buttons to select items on the on-screen menus.

- ⑫ **menu button (MENU)**  
Use this button to display the on-screen menu system, which contains additional instructions for special functions.
- ⑬ **cancel button (CANCEL)**  
Use this button to: cancel the entered channel number within three seconds; to erase the parental lock code during the parental lock sequence; to clear a channel programmed into super quick view memory; and to clear the settings of some on-screen menus.
- ⑭ **display button (DISPLAY)**  
Use to view an on-screen summary of the current TV settings for TV or cable functions, and the display related to Television Data Services (TVDS).
- ⑮ **home button (HOME)**  
Press to return to regular TV viewing from the on-screen displays and menus.
- ⑯ **number buttons (0-9)**  
Use to select a channel number, and to enter the parental lock code.
- ⑰ **off-timer button (OFF-T)**  
Use to program the TV to turn off automatically at a later time.



---

⑱ **picture-in-picture controls**

Use to control the special picture-in-picture (PIP) function.

- **PIP button (PIP)**---Press to see the reduced PIP image or cancel it.
- **channel button (VCR-CH)**---Press to change the channel of the reduced PIP image.
- **source button (SOURCE)**---Press repeatedly to switch the source of the reduced PIP image between the TV and the external input.
- **pause button (PAUSE)**---Press to freeze the reduced PIP image or cancel the image freezing. Also use for the advanced PIP functions.
- **enter button (ENTER)**---Press to switch back and forth between the reduced PIP image and the main image.
- **adjust up/down buttons, right/left buttons**---Press to move the position of the reduced PIP image.





## Connecting Your TV

This chapter offers step-by-step instructions for completing the most common hook-ups. It contains the following sections:

- ◆ **Overview of the Back Panel**
- ◆ **Basic Connections**

## ◆ Overview of the Back Panel

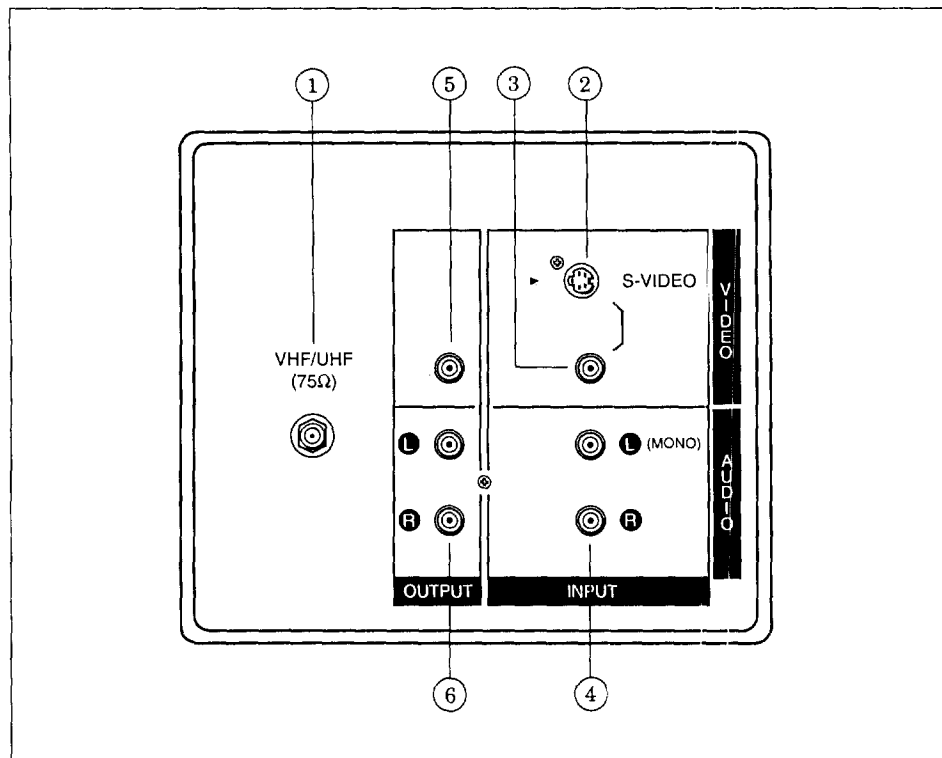

① **antenna terminal (VHF/UHF)**

Use to connect a VHF/UHF antenna.

② **S-VIDEO input terminal**

Use to connect the video out of a Super VHS (S-VHS) VCR to the TV.

▷ **Important:** If you connect Super VHS (S-VHS) equipment, External will automatically be the input for viewing your S-VHS VCR.

③ **video input terminal**

Use to connect the video output from a standard VCR or another component to the TV.

④ **audio input terminals**

Use to connect the audio output from a VCR or other equipment.

⑤ **video output terminal**

Use to connect the video of the TV to a VCR, Video Copy Processor, etc.

⑥ **audio output terminals**

Use to connect the audio of the TV to an audio system.

## ◆ Basic Connections

---

This section describes the equipment and procedures needed for basic hook-ups. (For more complex hook-ups, contact your dealer or local cable company.) The connections explained in this section are:

- **TV+antenna or cable without a decoder box,**
- **TV+cable with a decoder box,**
- **TV+separate UHF and VHF antennas,**
- **TV+VCR+antenna or cable without a decoder box,**
- **TV+VCR+cable with a decoder box, and**
- **TV+audio system.**

## TV+antenna or cable without a decoder box

### equipment you will need

If you have a standard 75-ohm coaxial cable, you will not need additional equipment. If your antenna has two leads (called flat twin leads), you'll need:

- 1 75-300 ohm transformer.

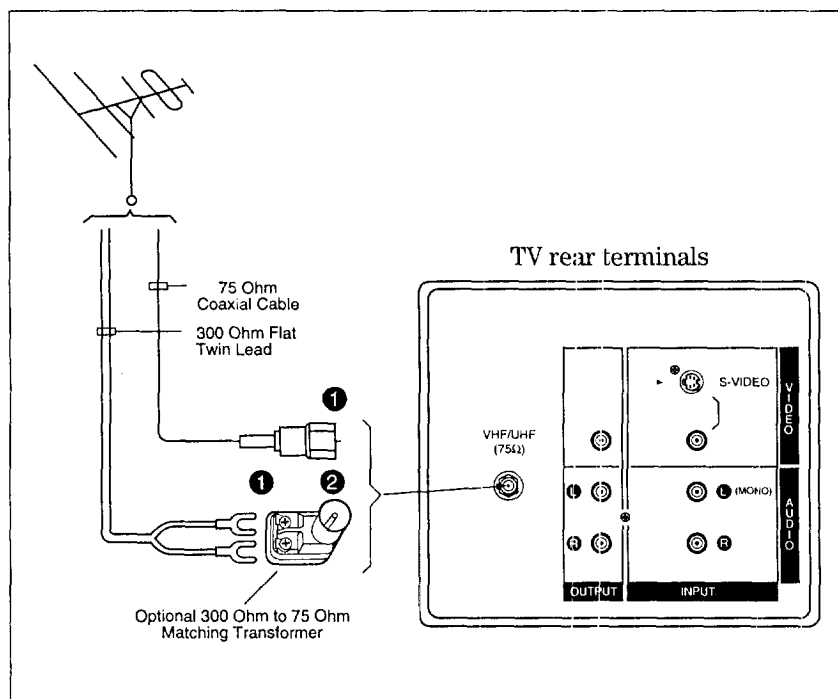
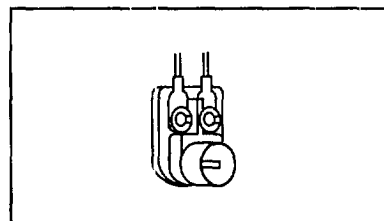

### connecting a cable

- 1 Push or screw the end of the cable onto the antenna terminal on the television.

### connecting an antenna with flat twin leads

- 1 Use a screwdriver to connect the leads to the transformer.
- 2 Push or screw the transformer onto the antenna terminal on the television.

## TV+cable with a decoder box

### equipment you will need

Use this hook-up if you need a decoder box to descramble cable signals. This hook-up will allow you to use your TV's remote control to change channels through the decoder box, if the cable layer of the remote control is set up to do so (See "Using the remote control" on page 42).

To complete the hook-up, you'll need:

- 1 length of 75 ohm coaxial cables.

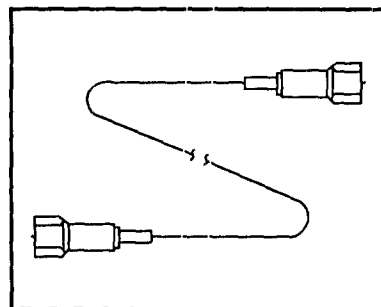

### Procedure

- 1 Connect the incoming cable to the IN terminal on the decoder box.
- 2 Connect a coaxial cable to the OUT terminal on the decoder box; connect the other end of this cable to the antenna terminal on the back of the TV.

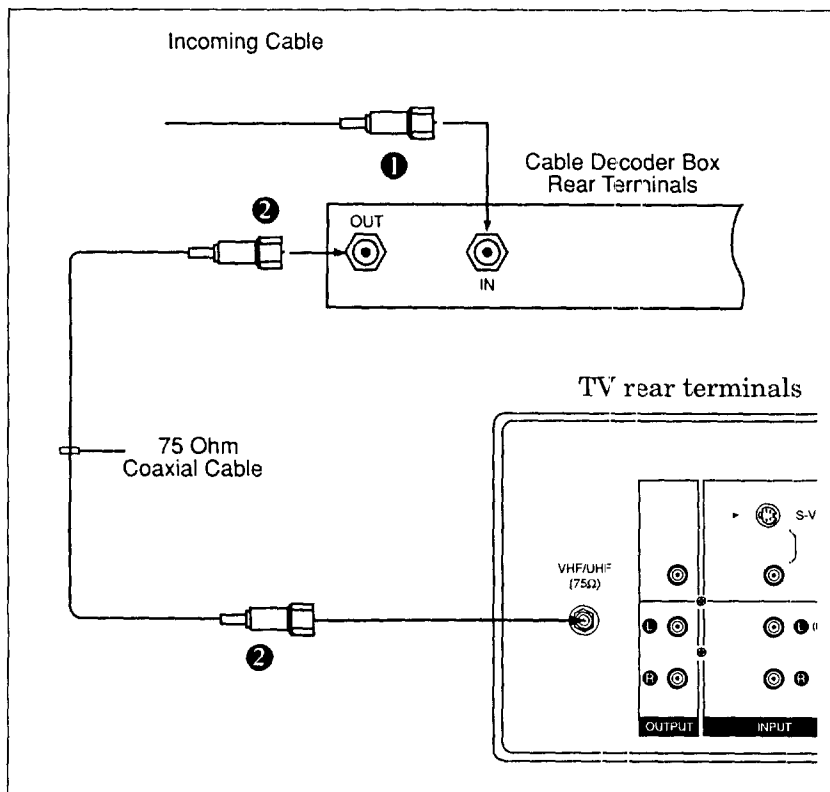

Basic Connections

## TV+ separate UHF and VHF antennas

### equipment you will need

If UHF and VHF signals are brought into your home with two separate antennas, you'll need to combine the antennas into a single wire to connect them to the TV. To do this you will need a UHF/VHF combiner. (There are different combiners for different kinds of leads. Check with your local electronics store for the kind of combiner you need.)

Pictured below is a standard combiner.

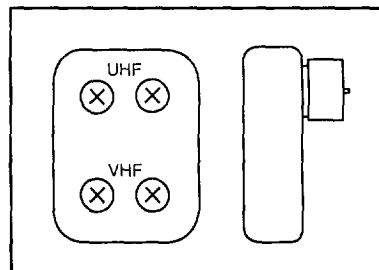

To connect separate UHF and VHF antennas to your television:

- 1 Connect the antenna leads to the UHF/VHF combiner.
- 2 Press the combiner onto the antenna terminal on the television.

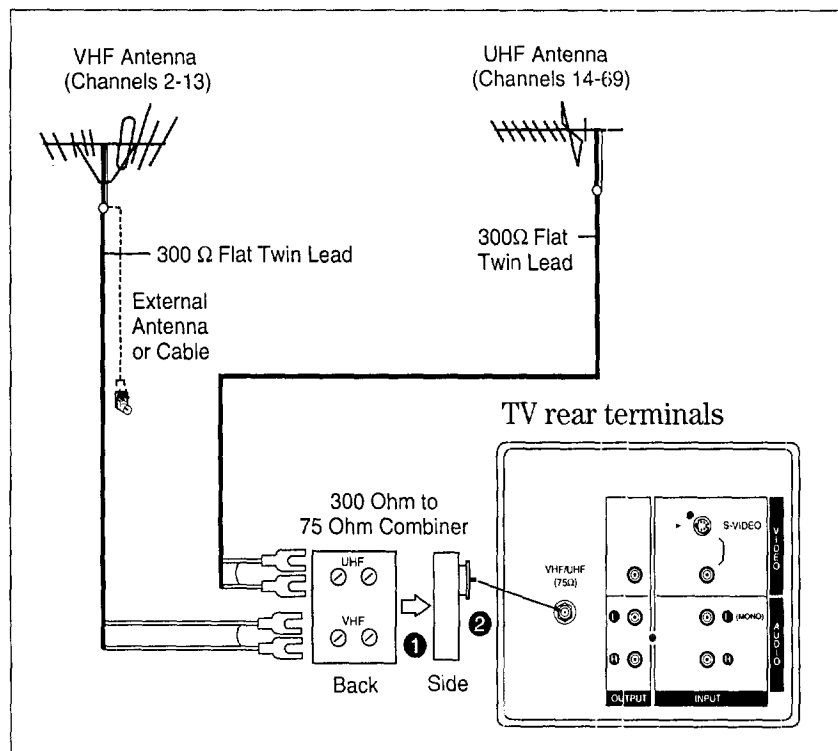



---

## TV+VCR+antenna or cable without a decoder box

### equipment you will need

You may want to connect a VCR along with your antennas or cable. To complete this hook-up, you may need the following equipment:

- 1 length of coaxial cable,

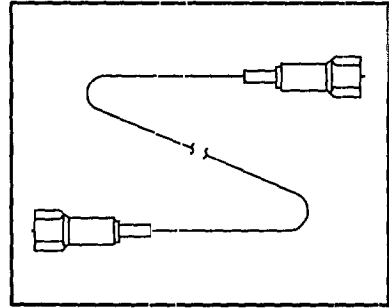

- 1 set of RCA pin-type audio cables,

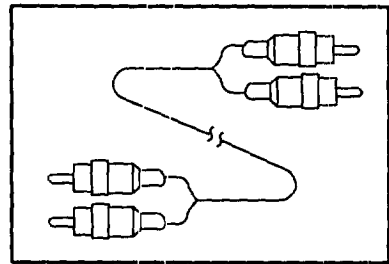

- 1 RCA pin type video cable,  
(if connecting a standard VCR),  
or

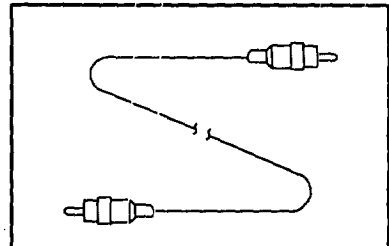

- 1 Super Video cable (S-VHS) for  
Super VHS VCRs.

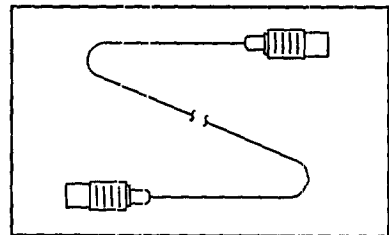

---

## **TV+VCR+antenna or cable without a decoder box (cont.)**

### **procedure**

**(See illustration on the following page.)**

- ❶ Connect the incoming cable or antenna to the ANTENNA IN terminal on the VCR.
- ❷ Connect one end of a coaxial cable to the ANTENNA OUT terminal on the VCR.
- ❸ Connect the other end of the cable to the antenna terminal on the TV.
- ❹ Connect an RCA pin-type video cable to the VIDEO OUT terminal on the back of the VCR. Connect the other end of this cable to the VIDEO INPUT terminal on the back of the television.

▷**Important:** If you are connecting a Super VHS (S-VHS) VCR, use a Super Video cable instead of an RCA pin-type video cable. Connect a Super Video cable to the S-VIDEO OUT terminal on the VCR. Connect the other end of this cable to the S-VIDEO INPUT terminal on the back of the television.

- ❺ Connect a set of RCA pin-type audio cables to the AUDIO OUT terminals on the back of the VCR. Use the red cable to connect the right (R) channel and the white cable for connecting the left (L) channel.

- ❻ Connect the other ends of this cable to the AUDIO INPUT terminals on the back of the television.

▷**Important:** If your VCR is monaural (non-stereo), you will only connect a single RCA pin-type audio cable. Connect the cable to the VCR, then connect the other end to the L (LEFT) audio input on the back of the television.

▷**Important:** If your VCR has the video channel switch, set to "OFF/AV" mode. See your VCR's owner's guide for details.

- ❼ Set the VCR to the playback mode.
- ❽ To view the VCR, select the external input source by using the INPUT button on the control panel or remote control.

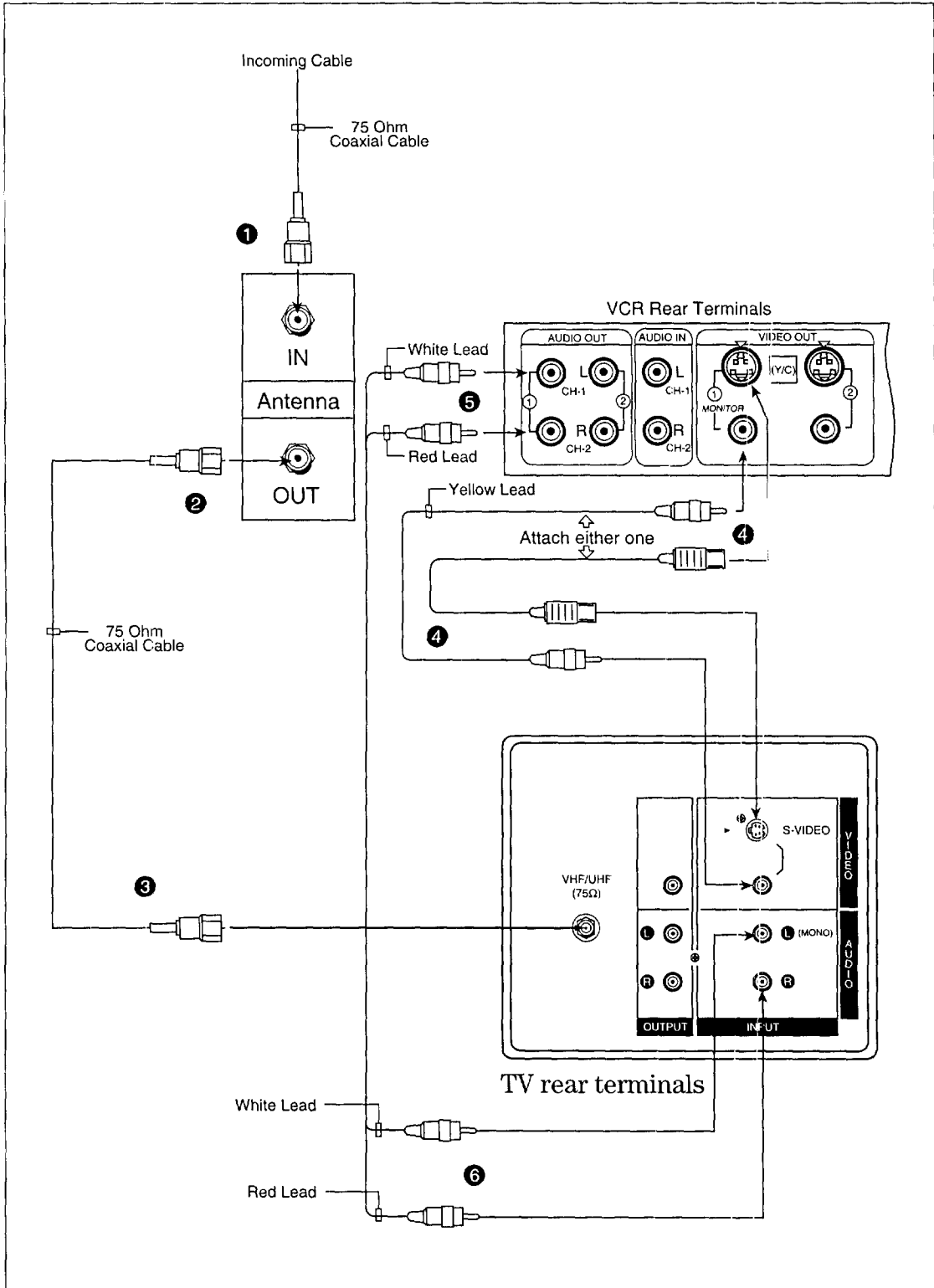

Basic Connections

---

## TV+VCR+cable with a decoder box

### equipment you will need

This hook-up will allow you to record scrambled channels. However, you should not change channels during recording.

To complete the hook-up, you'll need:

- 2 lengths of coaxial cable,
- 1 set of RCA pin-type audio cables,
- 1 RCA pin-type video cable, (if connecting a standard VCR), or
- 1 Super Video cable (S-VHS) for Super VHS VCRs.

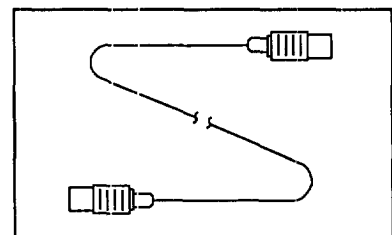
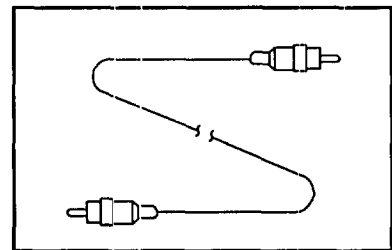
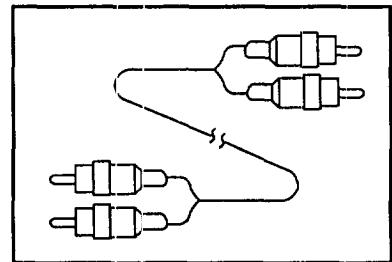
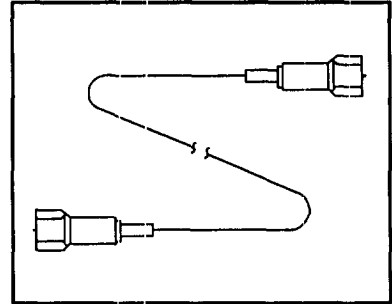

---

**procedure**

(See illustration on the following page.)

- ❶ Connect the incoming cable to the IN terminal on the decoder box.
- ❷ Connect a coaxial cable to the OUT terminal on the back of the decoder box; connect the other end of this cable to the ANTENNA-IN terminal on the back of the VCR.
- ❸ Connect the second coaxial cable to the ANTENNA-OUT terminal on the back of the VCR. Connect the other end of this cable to the antenna terminal on the back of the TV.
- ❹ Connect an RCA pin-type video cable to the VIDEO OUT terminal on the back of the VCR. Connect the other end of this cable to the VIDEO INPUT terminal on the back of the television.

▷ **Important:** If you are connecting a Super VHS (S-VHS) VCR, use a Super Video cable instead of an RCA pin-type video cable. Connect a Super Video cable to the S-VIDEO OUT terminal on the VCR. Connect the other end of this cable to the S-VIDEO INPUT terminal on the back of the television.

- ❺ Connect a set of RCA pin-type audio cables to the AUDIO OUT terminals on the back of the VCR. Use the red cable to connect the right (R) channel and the white cable for connecting the left (L) channel.

- ❻ Connect the other ends of this cable to the AUDIO INPUT terminals on the back of the television.

▷ **Important:** If your VCR is monaural (non-stereo), you will only connect a single RCA pin-type audio cable. Connect the cable to the VCR, then connect the other end to the L (LEFT) audio input on the back of the television.

▷ **Important:** If your VCR has the video channel switch, set to 'OFF/AV" mode. See your VCR's owner's guide for details.

- ❼ Set the VCR to the playback mode.

- ❽ To view the VCR, select the external input source by using the INPUT button on the control panel or remote control.

## TV+VCR+cable with a decoder box

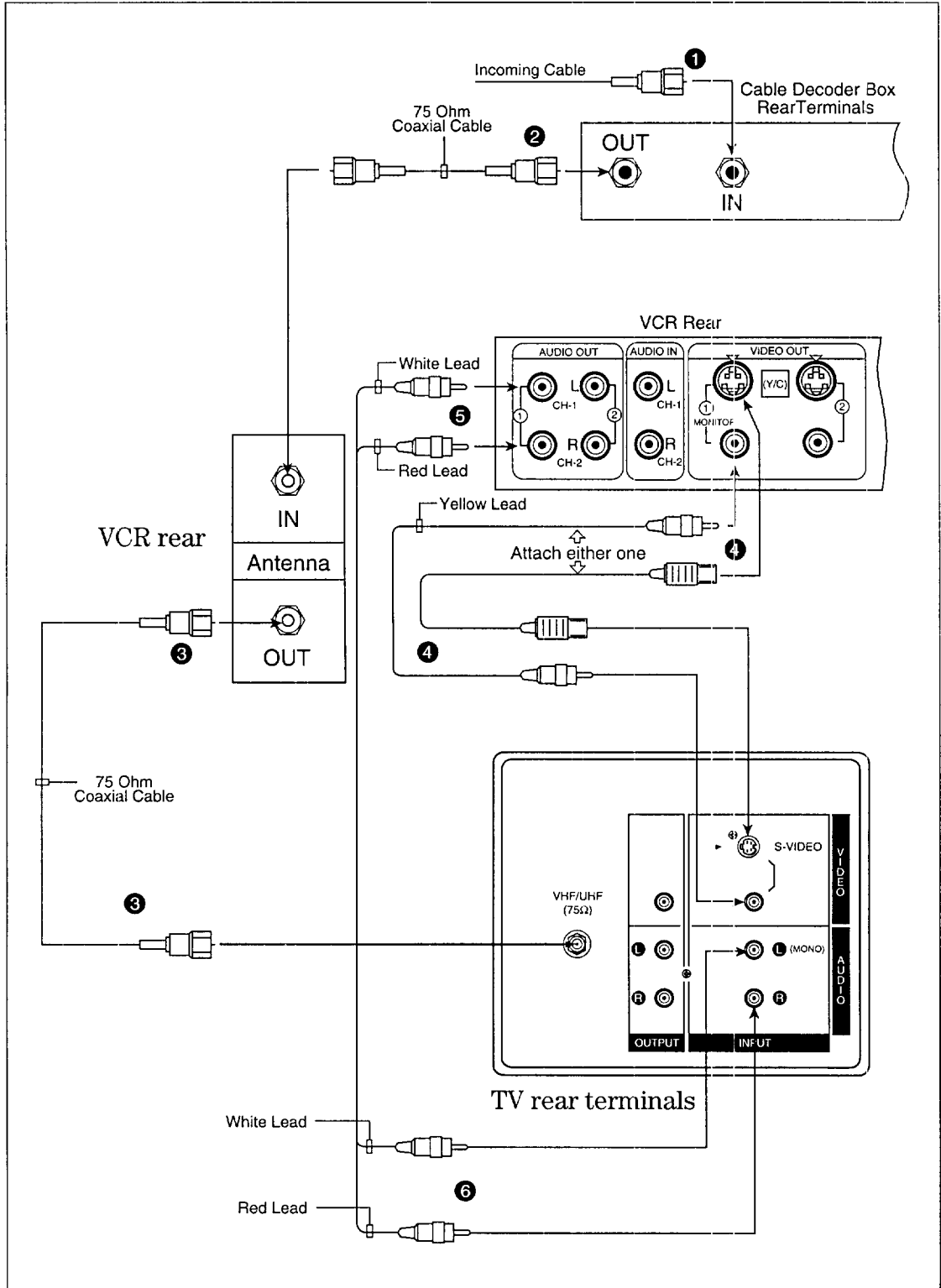

## TV+audio system

### equipment you will need

To hook-up an audio system, you will need:

- 1 set of RCA pin-type audio cables.

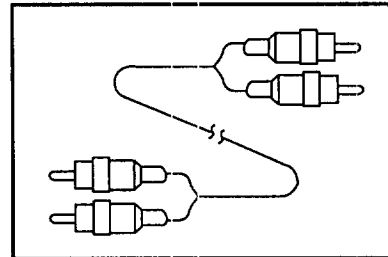

### Procedure

- 1 Connect one end of RCA pin-type audio cables to the AUDIO OUTPUT terminals on the back of the television. Use the red cable to connect the right (R) channel and the white cable to connect the left (L) channel.
- 2 Connect the other ends of this cable to the AUX IN terminals on the back of the audio system.
- 3 Turn off the television's speakers. To do this, press the AUDIO function button on the remote control until you see the SPEAKER display. Set the speakers to "Off" by pressing the ADJUST button. (See "Adjusting the sound," page 61.)
- 4 Set the audio system's input to the AUX position.

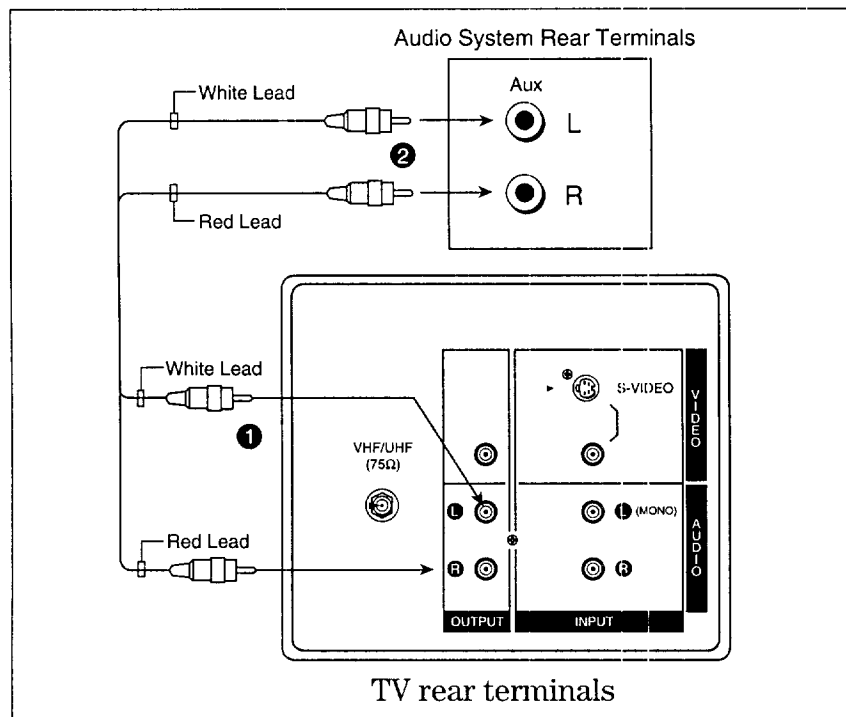







## Operating Your TV

Now that your TV is connected to the cable, antennas, or external components, it's time to enjoy your equipment. This chapter will explain how to operate the TV, first focusing on functions that are basic and easy and then explaining some advanced features.

This chapter explains:

- ◆ **Getting Started**
- ◆ **Using the Advanced Features**

## ◆ Getting Started

---

This section is designed to get you started enjoying your new TV. If you follow these procedures one by one, you will soon have a picture and can begin discovering everything your television can do.

You'll find information on:

- **Adjusting the color purity,**
- **Using the remote control,**
- **Turning the TV on/off,**
- **Selecting the input source,**
- **Changing channels,**
- **Understanding the on-screen menus,**
- **Setting the clock,**
- **Memorizing channels,**
- **Adding / deleting channels,**
- **Renaming the inputs,**
- **Selecting language,**
- **Using video mute,**
- **Using the power restore feature,**
- **Using the advanced PIP functions,**
- **Adjusting the sound,**
- **Adjusting the picture, and**
- **Using the closed caption decoder.**

## Adjusting the color purity (CS-35303, CS-35313 only)

Your MITSUBISHI CS-35303, CS-35313 color television has a large screen picture tube and color purity may be affected slightly by the earth's magnetic field. For best results, follow the instruction below for color purity adjustment.

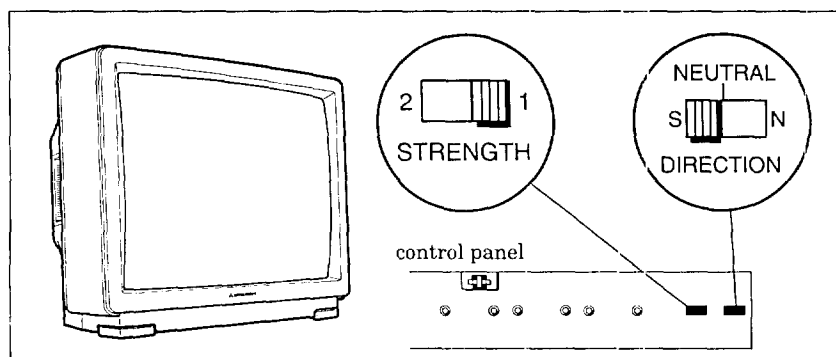

- ❶ Turn off the TV set.
- ❷ Select the desired location and install the set. Determine the compass direction where the set is facing. The direction is determined from the front of the screen facing forward.
- ❸ Select the position for the DIRECTION switch according to the chart below.

TV SET DIRECTION	DIRECTION SWITCH			STRENGTH SWITCH
	S	NEUTRAL	N	
North			X	} 1
North East			X	
North West			X	
South	X			
South East	X			
South West	X			
East		X		
West		X		

- ❹ Turn the TV on, and check the color performance.

- ▷ **Important:**
- If a color impurity is still present, change the STRENGTH switch to position "2". If a color impurity persists after changing the STRENGTH switch position, press the degauss button after a few minutes.
  - The color purity switches must be adjusted each time the set is moved to a new location.
  - If a color impurity still persists after the re-adjustment of color purity switches, contact your MITSUBISHI dealer or MITSUBISHI Authorized Warranty Service Center.

---

## Using the remote control

### operating Mitsubishi components

This remote control unit comes programmed to operate Mitsubishi TVs and VCRs. The select buttons determine which component the remote control will operate.

The following buttons are available for operation of this TV set.

- power button
- pause button
- mute control
- super quick view button
- quick view button
- volume control
- input button
- channel control
- enter button
- audio and video controls
- menu button
- cancel button
- display button
- home button
- off-timer button
- number buttons
- PIP controls

### operating VCRs from other manufacturers or cable box

The remote control is pre-set to operate Mitsubishi VCRs, but it can also operate VCRs from other manufacturers as well. If you have a VCR from another manufacturer, or if you have a cable box, it is advisable to set up the remote control.

- ▷ **Important:** Each layer (CABLE, VCR-A or VCR-B) can be set for either a cable box or a VCR.

<setting up the remote control to operate your VCR>

- ❶ Turn off your VCR.
- ❷ Choose the layer using the select button on the remote control: VCR-A, VCR-B or CABLE.
- ❸ While holding in the POWER button on the remote control, enter the code number listed in the chart on the following page for your brand of VCR. Be sure to enter both digits of the code number. (If more than one code number is listed, try the first one. If that code does not work, try the next one until you find the correct code.)
- ❹ Release the POWER button.
- ❺ Press the POWER button again. Your VCR should turn on. If the VCR turns on, your remote control is now set to operate your VCR.

If your VCR does not turn on, repeat the instructions, trying each code number listed for your brand of VCR.

Chapter 3 : Operating Your TV

If your VCR is this brand...	...enter this code	If your VCR is this brand...	...enter this code
Mitsubishi (A)	01	Philips	03, 10, 11
Mitsubishi (B)	02	Quasar	03
Canon	03	RCA	08, 13, 20
Emerson	04, 05	Sanyo	14
Funai	06	Scot	15
GE	03	Sharp	16
Goldstar	07	Sony	17, 18
Hitachi	08	Sylvania	03, 10, 11
JVC	09	Symphonic	06
Magnavox	03, 10, 11	Teknika	04, 06
Multitech	06	Toshiba	15
NEC	12	Totevision	07
Panasonic	03	Zenith	19
Philco	03, 10		

<setting up the remote control to operate your cable box>

- ❶ Turn off your cable box.
- ❷ Choose the layer using the select button on the remote control: CABLE, VCR-A or VCR-B
- ❸ While holding in the POWER button on the remote control, enter the code number listed in the chart on the next page for your brand of cable box. (If more than one code number is listed, try the first one. If that code does not work, try the next one until you find the correct code.)
- ❹ Release the POWER button.
- ❺ Press the POWER button again. Your cable box should turn on. If the cable box turns on, your remote control is now set to operate your cable box.

If your cable box does not turn on, repeat the instructions above, trying each code number listed for your brand of cable box.

## Using the remote control (cont.)

If your cable box is this brand...	...enter this code	If your cable box is this brand...	...enter this code
Zenith	51	Tocom	67, 68, 72
Hamlin	52, 53, 69	Panasonic	63, 70
Jerrold	54, 57, 58, 59, 60, 85, 87	Macom	71
G.I.	55, 56	Philips	73, 74, 75, 76, 77, 93, 94, 95, 96, 97, 98, 99
Oak	61, 62, 82	Regency	79
Pioneer	64, 65, 84		
S.A.	66, 86, 88, 89, 91, 92		

- ▷ **Important:** Sometimes manufacturers will change their products, or they may use more than one code. If this is the case, your remote may not be able to operate your VCR or cable box.
- ▷ **Important:** Each layer (CABLE, VCR-A or VCR-B) can be set for either a cable box or a VCR.
- ▷ **Important:** When you replace the batteries in your remote control, the remote will return to its initial setting.

<using your remote control to operate your VCR>

After you have set up your remote control for your particular brand of VCR, you can use the remote to operate your VCR.

- ① Choose the layer using the select button on the remote control: VCR-A, VCR-B or CABLE.
- ② Point the remote control at the VCR and press the desired buttons.

If you are using a Mitsubishi VCR, you will be able to use all of the buttons on the remote control to operate your VCR except for MUTE, VOLUME and the PIP function buttons.

If you are using another brand of VCR, you can use the POWER, CHANNEL, REC, STOP, PAUSE, REW, PLAY and FF buttons to operate your VCR.

---

<using your remote control to operate your cable box>

After you have set up your remote control for your particular brand of cable box, you can use the remote to operate your cable box.

- ❶ Choose the layer using the select button on the remote control: VCR-A, VCR-B or CABLE.
- ❷ Point the remote control at the cable box and press the desired buttons.

Only the POWER and CHANNEL buttons can be used when operating your cable box.

---

## Turning the TV on/off

- ▷ **Important:** Before using the remote control to operate the TV, press the TV select button.

Use the POWER button on either the control panel or the remote control to turn the TV on and off.

- ▷ **Important:** Even with the power turned off, there is a small current that continues to flow into the TV. This maintains any changes to the setting as well as operates the built-in clock and timing functions. Unplugging the set will erase these settings requiring that you set them again. Unplug the TV only when it won't be used for a long time.

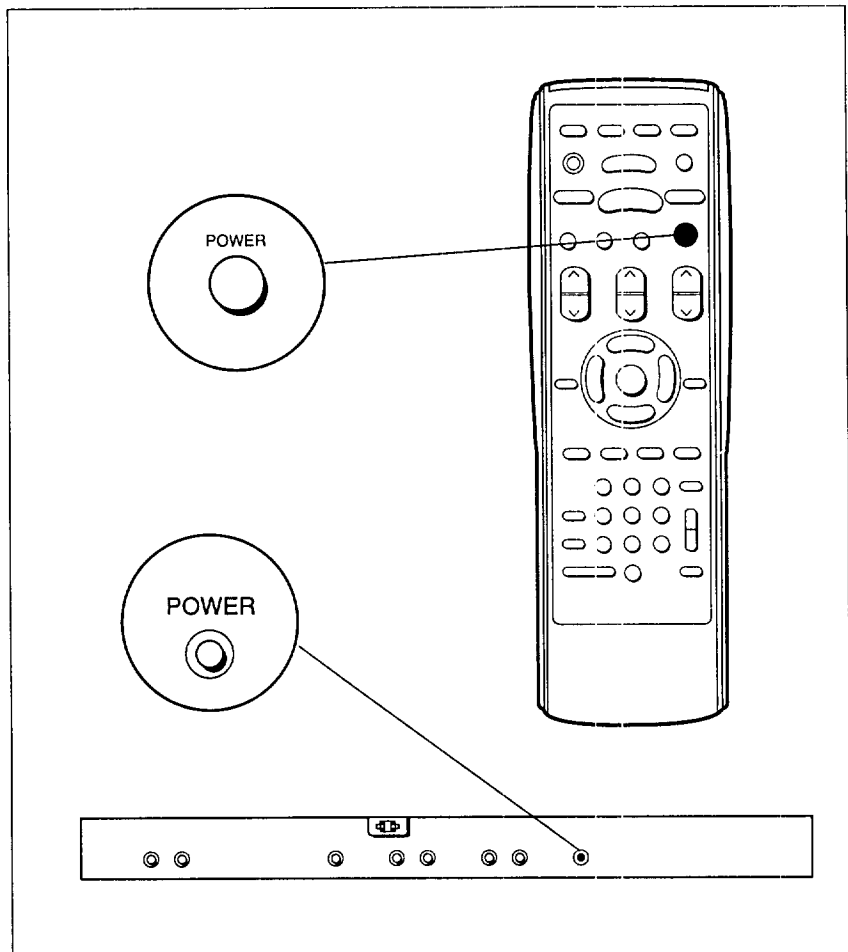



## Selecting the input source

Press the input button (INPUT) on the control panel or on the remote control to select the input source you wish to view: TV or External (Ext).

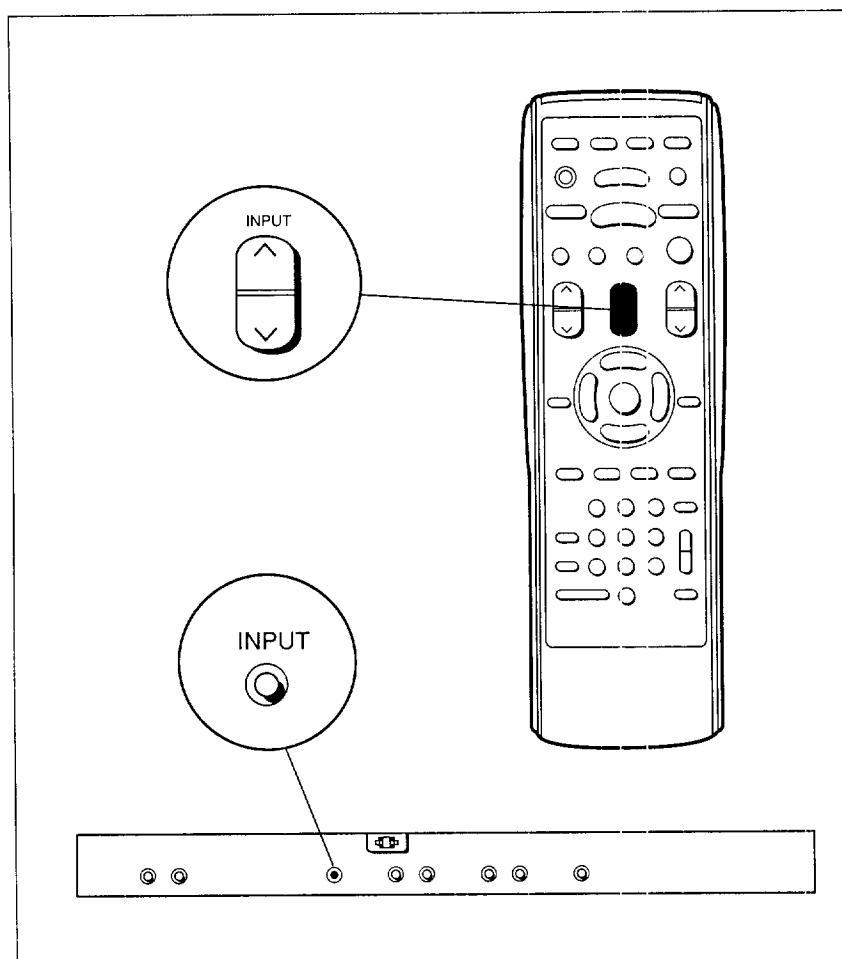

---

## Changing channels

Your TV offers you four ways of changing channels once their numbers have been programmed into channel memory.

- selecting a channel using the automatic channel scan feature.
- directly accessing a channel by pressing the number buttons.
- using the special quick view option to switch to the special memorized channel, and
- using the Super Quick View function to alternate between special channels programmed for quick viewing.

▷ **Important:** To change channels faster, use either of the following procedures:

- Enter three digits for every channel number, using zeros where needed. (For example, enter "004" to view channel 4 and "028" to view channel 28.)
- Press the ENTER button after selecting the number of the channel. (For example, press "4" and "ENTER" to view channel 4.)

▷ **Important:** Cable stations channel numbers 0 and greater than 126 are unassigned. TV stations 0, 1 and 70 through 999 are unassigned. If these channel numbers are pressed, the channel remains unchanged.

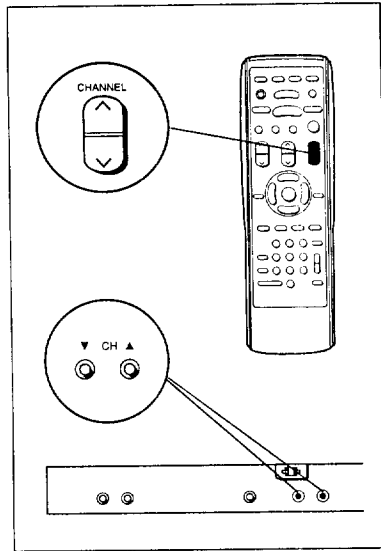

### changing channels automatically

To change channels:

- ① Press one of the channel controls (CH, CHANNEL) on the control panel or on the remote control. The TV automatically goes to the next broadcasting station.

▷ **Important:** The channel controls (CHANNEL) will work only after channels have been programmed into memory. (See "Memorizing channels," page 54.)

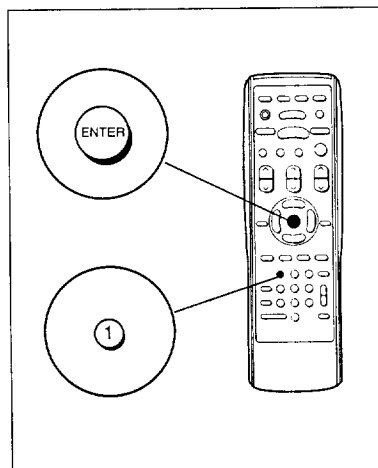

### changing channels directly

To move directly to a particular channel without going through the programmed channels:

- ① Use the remote control to select the number of the channel you want to view.
- ② Press the ENTER button.

## Changing channels (cont.)

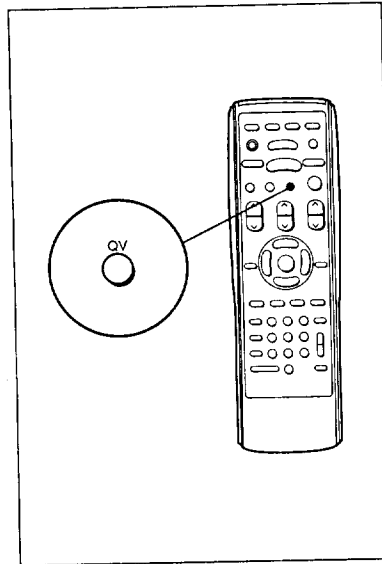

### using the quick view option

To use quick view:

- 1 Select the channel you wish to memorize as the quick view channel.
- 2 Press the QV button for about 3 seconds. On releasing this button, the channel number will appear on the screen.
- 3 Press the quick view (QV) button to view the QV channel.

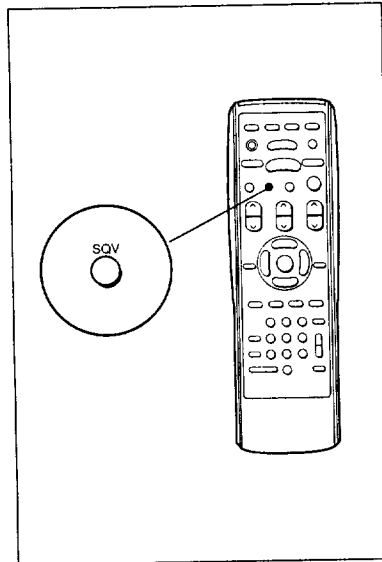

### using the super quick view option

To view selected channels programmed into super quick view memory:

- 1 Enter the desired channel into Super Quick View memory. (See "Using the Super Quick View tuning," page 69.)
- 2 Press the SQV button to view the desired channels in sequence.

---

## Understanding the on-screen menus

One of the distinctive features of this TV is an on-screen menu system that provides step-by-step instructions for using some of the TV's special capabilities.

When using any of the on-screen menus, keep the following in mind:

- The on-screen menus will clear if no item is selected within 5 minutes.
- Unavailable menu items are indicated in light blue.
- Some on-screen menu items must be set before other items are available. For example, "Set the timer" will only be available if "Set the clock" has been set.
- You can exit the on-screen menus any time by pressing the MENU button repeatedly. You will then return to regular TV viewing.
- You can also exit the on-screen menus by pressing the HOME button on the remote control.

## Setting the clock

Your TV contains an internal clock to indicate the current time. If there is a broadcaster in your area that is sending the current time along with its regular broadcast signal, then your TV can automatically set its clock with this signal. Otherwise, you can set the clock yourself.

```
TV Main Menu
-----
Your choices are:
▶ First Time Set-Up
  Customize Viewing
  Advanced Features

Use ADJUST to select.
Then press ENTER.
Press MENU to exit menus.
```

1 Press the MENU button on the remote control. The TV Main Menu will appear on the screen.

2 Select "First Time Set-Up" using the ADJUST button; then press the ENTER button.

```
First Time Set-Up
-----
▶ Set the clock
  Memorize channels
  Add/delete channels

Use ADJUST to select.
Then press ENTER.
Press MENU to return to
TV Main Menu.
```

3 You will see the "First Time Set-Up" screen. Select "Set the clock" using the ADJUST button; then press the ENTER button.

4 If you want your TV to set its clock automatically, use the ADJUST button to set "Auto clock" to "On"; if you want to set the clock yourself, set "Auto clock" to "Off."

<automatic setting>

```
Set the clock
-----
▶ Auto clock  On
  Day         --
  Clock       --
  Time zone   Atlantic
  Daylight savings  On

Use ADJUST to select.
Then press ENTER.
Press MENU to return to
First Time Set-Up Menu.
```

• Set "Auto clock" to "On" using the ADJUST button and press the ENTER button.

```
Set the clock
-----
Auto clock  On
Day         Monday
Clock       10:00 am
▶ Time zone  Atlantic
  Daylight savings  On

Use ADJUST to select.
Then press ENTER.
Press MENU to return to
First Time Set-Up Menu.
```

• Select the "Time zone" you are in using the ADJUST button; then press the ENTER button. The available time zones are: Atlantic, Eastern, Central, Mountain, Pacific, Alaska and Hawaii.

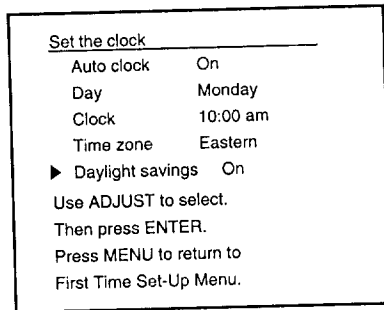

- If you follow daylight savings time, set the "Daylight savings" to "On" using the ADJUST button. If you do not follow, set it to "Off." Then press the ENTER button.
- The automatic setting is completed, and the clock will start automatically.

The screen will return to the "First Time Set-Up" menu.

▷ **Important:** The TV can only set the clock automatically ("Auto clock") when there is a broadcaster in your area that is sending the current time via Television Data Services (TVDS). The clock will start just after the TV receives the time data.

<manual setting>

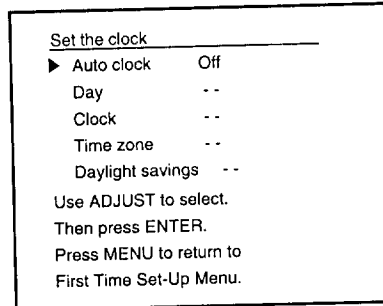

- Set "Auto clock" to "Off" using the ADJUST button and press the ENTER button.

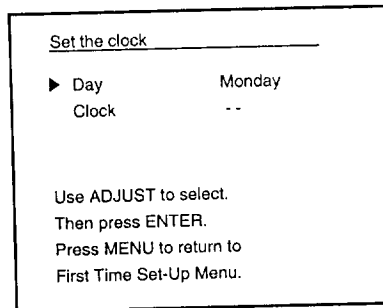

- Select the "Day" using the ADJUST button and press the ENTER button.

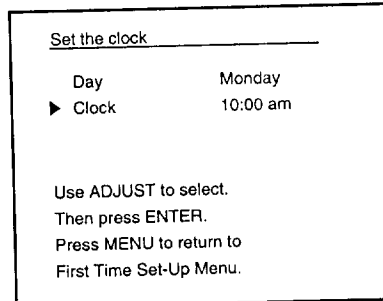

- Set the "Clock" using the ADJUST button.
- After setting Day & Clock, press the ENTER button when the precise minute arrives to start clock.

The screen will return to the "First Time Set-Up" menu.

---

## Memorizing channels

Your TV automatically memorizes the channels you can receive. Once channels are memorized, you can scan through them using the channel control on the remote control and control panel.

To memorize channels:

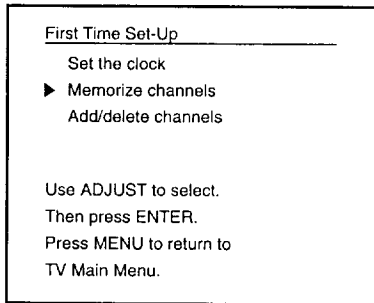

❶ Press the MENU button on the remote control. The TV Main Menu will appear on the screen.

❷ Select "First Time Set-Up" using the ADJUST button; then press the ENTER button.

❸ Select "Memorize channels" using the ADJUST button; then press the ENTER button.

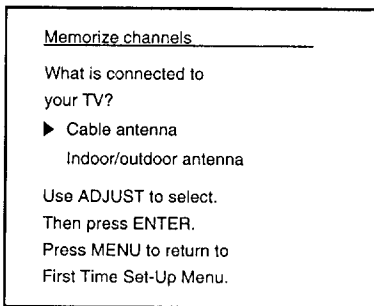

❹ The instructions for memorizing channels will appear.

Use the ADJUST button to choose the type of antenna you connected: Cable antenna or Indoor/outdoor antenna. Then press the ENTER button.

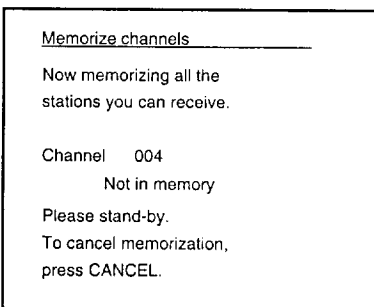

❺ You will see a message that states that channel memorization is in progress. The channel in memorization will have the word "In memory," channels not in memory say "Not in memory." You may stop channel memorization at any time by pressing the CANCEL button.

▷ **Important:** The channel controls (CHANNEL) will work only after channels have been programmed into memory. After memorizing, use the channel controls (CHANNEL) on the control panel or on the remote control to automatically advance to the next memorized channel. Use the number buttons to select individual channels.



## Adding and deleting channels

After all available channels have been programmed automatically, channels with weaker signals can be added or deleted by using the following procedure.

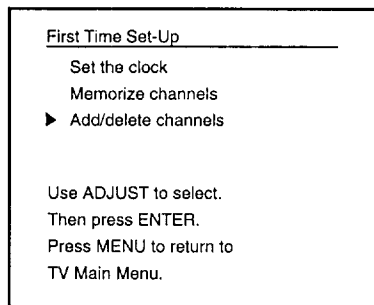

- 1 Press the MENU button on the remote control. The TV Main Menu will appear on the screen.
- 2 Select "First Time Set-Up" using the ADJUST button; then press the ENTER button.
- 3 Select "Add/delete channels" using the ADJUST button; then press the ENTER button.

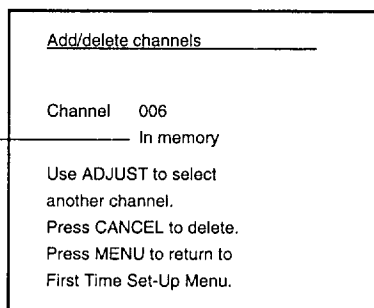

Either "In memory" or "Not in memory" will appear.

- 4 The "Add/delete channels" screen will appear.

Select the channel you would like to add or delete using the ADJUST button; then press the ENTER or CANCEL button. Channels that are in memory have the word "In memory"; channels not in memory say "Not in memory."

- 5 Following the additional on-screen instructions, add a channel into channel memory or delete a channel from channel memory.

▷ **Important:** In this menu, the CHANNEL ▲ button changes to a channel with a higher number; the CHANNEL ▼ button changes to a channel with a lower number.

## Renaming the inputs

This feature allows you to rename the external inputs. After renaming, the new name will appear on the screen display.

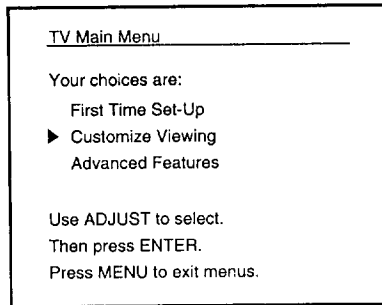

➊ Press the MENU button on the remote control. The TV Main Menu will appear on the screen.

➋ Select "Customize Viewing" using the ADJUST button; then press the ENTER button.

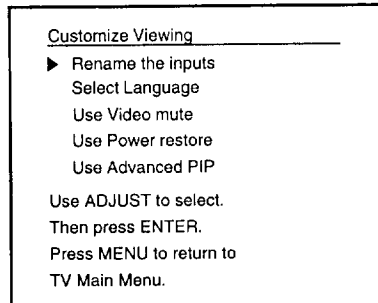

➌ You will see the "Customize Viewing" screen. Select "Rename the inputs" using the ADJUST button; then press the ENTER button.

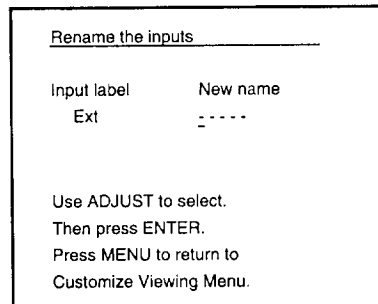

➍ Set the new name using the ADJUST button and the ENTER button.

You can rename the inputs using letters (A~Z), numbers (0~9), or symbols (: / . , ( ) ! " # \$ % & ' blank + ; < = > ? blank -).

When you press the CANCEL button while setting the name, the cursor will move to the left position. You can clear the entire name by pressing CANCEL when the cursor is at the first position.

➎ After naming, press the MENU button; the screen will return to the "Customize Viewing" menu.

---

## Selecting language

This TV allows you to see three different language on-screen menus: English, Spanish and French.

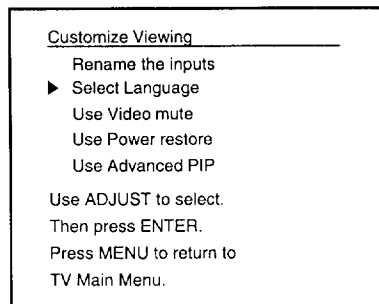

- 1 Press the MENU button on the remote control. The TV Main Menu will appear on the screen.
- 2 Select "Customize Viewing" using the ADJUST button; then press the ENTER button.
- 3 Select "Select Language" using the ADJUST button; then press the ENTER button.

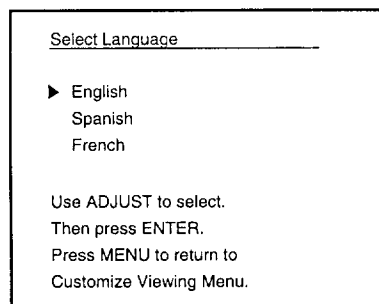

- 4 Select the language for on-screen menu using the ADJUST button.
- 5 Press the ENTER or MENU button to return to the "Customize Viewing" menu.

---

## Using video mute

With using the video mute function, any blank section of video tape is replaced by a blue screen. The sound is also turned off. If there is a case where you might wish to try viewing the playback of noisy tape, you can turn the video mute off.

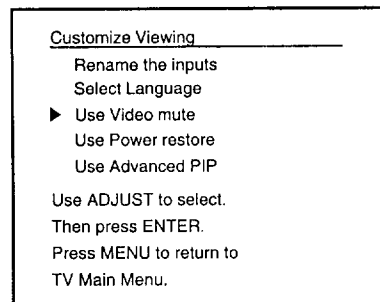

① Press the MENU button on the remote control. The TV Main Menu will appear on the screen.

② Select "Customize Viewing" using the ADJUST button; then press the ENTER button.

③ Select "Use Video mute" using the ADJUST button; then press the ENTER button.

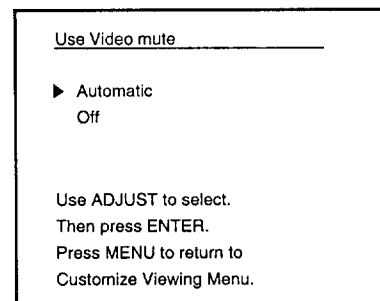

④ Select either "Automatic" for video mute on or "Off" for video mute off using the ADJUST button.

⑤ Press the ENTER or MENU button to return to the "Customize Viewing" menu.

---

## Using the power restore feature

When this feature is used, the TV will automatically turn on when electric current is supplied. This feature is useful when, for example, your TV is plugged into an outlet that you control with a wall switch.

To use the power restore feature:

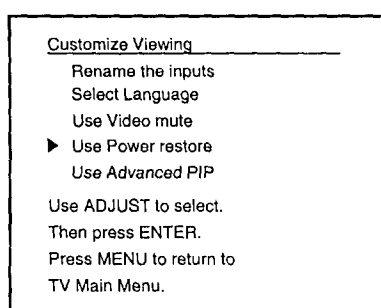

① Press the MENU button on the remote control. The Main Menu will appear on the screen.

② Select "Customize Viewing" using the ADJUST button; then press the ENTER button.

③ Select "Use Power restore" using the ADJUST button; then press the ENTER button.

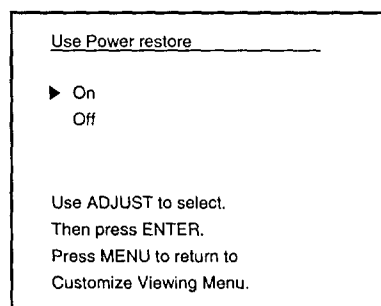

④ The "Use Power restore" screen will appear.

Select either "On" or "Off" to switch power restore feature to on or off using the ADJUST button.

⑤ Press the ENTER or MENU button to return to the "Customize Viewing" menu.

▷ **Important:** In order for this feature to work, you must leave your TV turned on when you turn off the electric current.

▷ **Important:** Even when the power restore feature is used, unplugging the set requires that you reset functions such as the built-in clock and timing functions.

---

## Using the advanced PIP functions

You can use the pause button in the Picture-in-Picture mode to display special PIP features. Select one of the following settings:

- TV Still,
- Snap-shot, or
- Replay.

In "TV Still," the PIP image switches between still and moving. In "Snap-shot," you can view and move the frozen PIP image. In "Replay," you can view still PIP images in sequence for a "strobe" animation effect. These images will appear in sets of three (from a total of seven stored images) at the speed you select. (See "Using the Picture-in-Picture (PIP) Mode," pages 76-80).

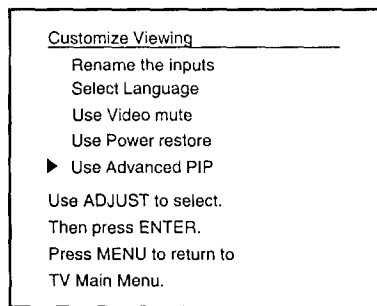

① Press the MENU button on the remote control. The TV Main Menu will appear on the screen.

② Select "Customize Viewing" using the ADJUST button; then press the ENTER button.

③ Select "Use Advanced PIP" using the ADJUST button; then press the ENTER button.

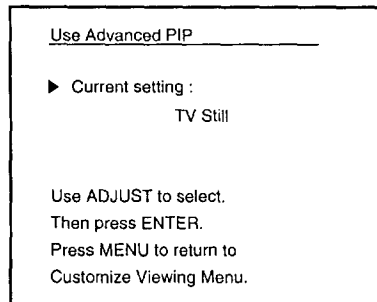

④ Select the current setting: TV Still, Snap-shot or Replay, using the ADJUST button. Then press the ENTER button.

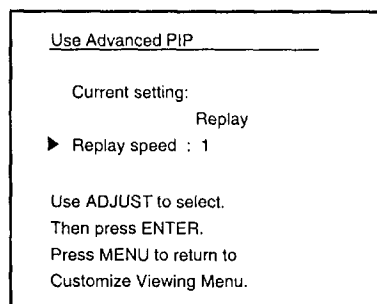

• When you select "Replay," the next option will be "Replay speed." Use the ADJUST button to set the replay speed from 1-9: 1=short interval and 9=long interval. Press ENTER. The main image will replay in sets of three in a "strobe" animation effect at the speed you selected.

⑤ Press the MENU button to return to the "Customize Viewing" menu.

---

## Adjusting the sound

You can adjust all of your television's sound functions by using a pair of buttons: select a function with the AUDIO button and adjust the function with the ADJUST button or right/left button. You use the ADJUST button to:

- select a position (e.g., stereo),
- increase or decrease the function (e.g., bass), or
- shift from one end of a scale to the other (e.g., balance).

After adjusting the sound, an on-screen display will indicate the function and level you've selected.

### what you'll adjust:

"Listen to: Stereo/SAP/Mono" allows you to change the audio reception mode to stereo, separate audio programming (SAP), or monaural (mono), depending on the type of broadcast you are receiving. As you select the reception mode, remember the following:

- The "Stereo" setting allows you to receive both mono and stereo broadcasts.
- The separate audio programming ("SAP") setting offers you the option of listening to either of two separate audio programs. For example, a combination television/radio station may broadcast through the TV.
- The "Mono" setting reduces unwanted background noise when a stereo broadcast is coming in weak. When you use the "Mono" setting, you will hear the broadcast in monaural even when the broadcast signal is in stereo.

▷ **Important:** An on-screen display appears when programs are broadcast in stereo or when separate audio programming (SAP) is available.

"Bass" controls the volume of low frequency sound.

"Treble" controls the volume of high frequency sound.

"Balance" adjusts the level of sound between the left and right speakers.

"Surround: Off/Simulate/Hall" allows you to simulate or expand stereo sound.

- "Off" does not change the sound.

- "Simulate" gives you a pseudo-stereo effect when receiving monaural sound broadcasts.
- "Hall" makes stereo sound seem wider and extend around behind you.

"Speaker: On/Off" turns the TV speakers on or off. Set to "On" for normal operation. Set to "Off" if you connected your TV to an audio system.

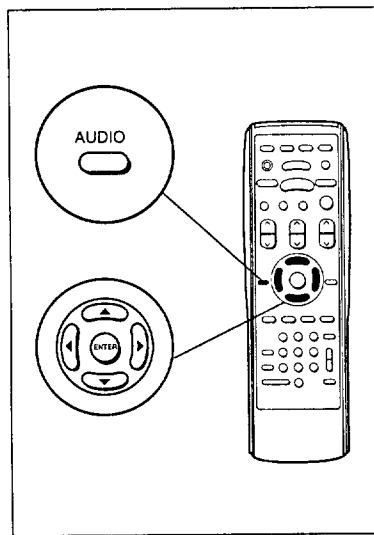

#### **adjusting the audio functions**

- ① Use the AUDIO button on the remote control to select one of the functions.
- ② Use the ADJUST (up/down) button or right/left button on the remote control to adjust the function.



---

## Adjusting the picture

You can adjust all of your television's picture functions by using a pair of buttons: select a function with the VIDEO button and adjust the function with the ADJUST button or right/left button. You use the ADJUST button to:

- shift from one end of a scale to the other (e.g., tint),
- increase or decrease the function (e.g., color),
- select a position (e.g., color temperature).

After adjusting the picture, an on-screen display will indicate the function and level you've selected.

### what you'll adjust:

"Tint" adjusts the proportion of red to green that determines the delicate tones of color.

"Color" determines the intensity of the color.

"Contrast" controls the level of white-to-black in the picture.

"Brightness" controls the light level of the image on screen.

"Sharpness" adjusts the detail and clarity of the picture.

"Color temp(eration): Low/Middle/High" is used to change the relative warmth of the picture.

"**cc** (closed captioning): 1/2/3/4/Text 1/Text 2/Text 3/Text 4/When muting/Off" is used to display the text information on the TV screen. For details, see "Using the closed caption decoder," page 64.

### adjusting the video functions

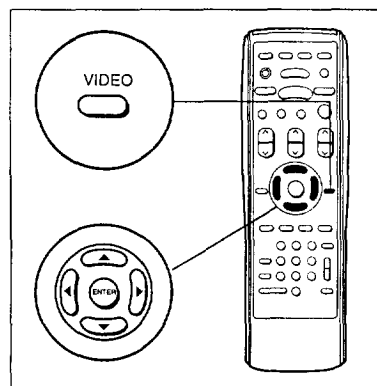

- 1 Use the VIDEO button on the remote control to select one of the functions.
- 2 Use the ADJUST (up/down) button or right/left button on the remote control to adjust the function.

---

## Using the closed caption decoder

Many broadcasters now supply closed captioning information along with their regular broadcasts.

There are two types of captioning that broadcasters can send: "standard" and "text." Standard captioning is related to the program that is being shown. Standard captioning usually follows the dialogue of the characters on-screen. Text captioning does not usually relate to the program being shown. It often contains information such as weather or news. Text captioning often blocks out your view of the program you are watching.

Your TV can decode four different "standard captioning" signals and four different "text captioning" signals on each TV channel.

To use the closed caption decoder:

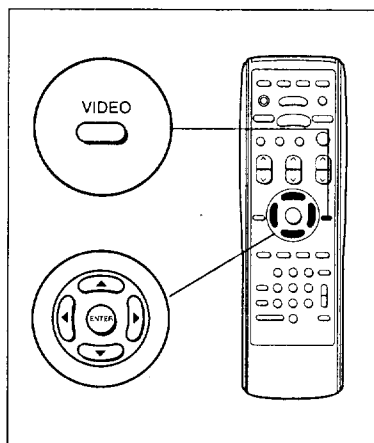

- 1 Press the VIDEO button on the remote control until the closed captioning ( **CC** ) display appears on the screen.
- 2 Press the ADJUST button or right/left button on the remote control to select the captioning signal you wish to display: **CC** 1/ **CC** 2/ **CC** 3/ **CC** 4/ **CC** Text 1/ **CC** Text 2/ **CC** Text 3/ **CC** Text 4/ **CC** When muting/Off.

You can choose to display one of four "standard captioning" signals (indicated by the word **CC** and a number), to display one of four "text captioning" signals (indicated by the word "Text" and a number), to display captions when muting, or to turn the captions off.

If you select "When muting," the standard captioning signal **CC** 1 will appear whenever you use the MUTE button.

### uses for closed captioning

Closed captioning can be used in many ways, such as:

- helping children learn to read,
- learning a foreign language, and
- using the television without disturbing others.

▷ **Important:** If you cannot display any captions on the screen, please keep in mind that not all broadcasters, video tapes, or laserdiscs supply closed caption signals.

Closed captions will not appear if you are playing a video tape that is worn or old.

## ◆ Using the Advanced Features

---

This section explains how to use some of the more advanced functions. You'll learn:

- **Setting the timer,**
- **Using the parental lock, and**
- **Using the Super Quick View tuning.**

## Setting the timer

This special feature allows you to program the TV to turn on automatically at a preset time. To set the timer:

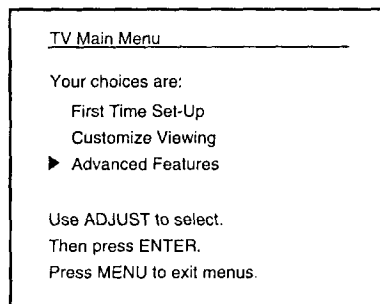

1 Press the MENU button on the remote control. The Main Menu will appear on the screen.

2 Select "Advanced Features" using the ADJUST button; then press the ENTER button.

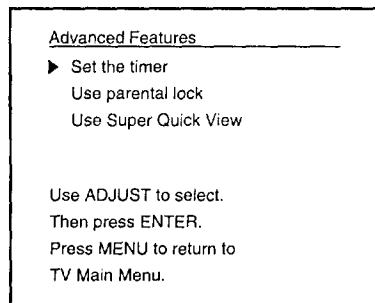

3 You will see the "Advanced Features" screen. Select "Set the timer" using the ADJUST button; then press the ENTER button.

4 Following the additional on-screen instructions, set Day, Start time and Channel using the ADJUST button and the ENTER button.

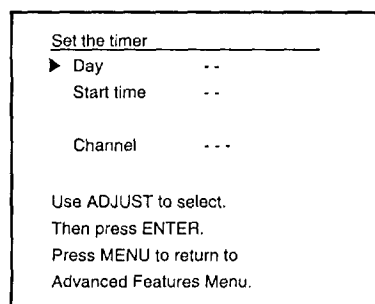

After setting the timer, confirm the program timer indicator lights up. The indicator will not light up when using the menus, or when you have locked the TV.

When you press the CANCEL button while setting the timer, the cursor will move to the previous item. To clear the timer, press the CANCEL button with the cursor at the "Day" position.

▷ **Important:** When the timer turns the TV on, the display will flash as a warning. If you do not press a TV function button for about 5 minutes, the TV will automatically turn off. Pressing a TV function button (ex. display button) causes the TV to remain on and the display to stop flashing.

## Using the parental lock

This special feature locks the entire TV or one particular channel to prevent others from watching it.

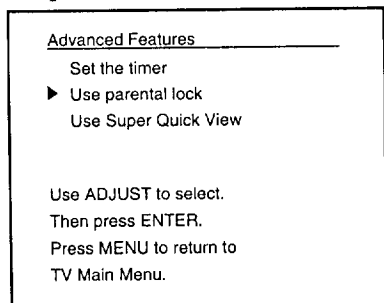

❶ Press the MENU button on the remote control. The Main Menu will appear on the screen.

❷ Select "Advanced Features" using the ADJUST button; then press the ENTER button.

❸ Select "Use parental lock" using the ADJUST button; then press the ENTER button.

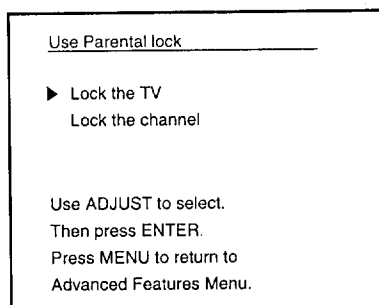

❹ Select "Lock the TV" or "Lock the channel" using the ADJUST button; then press the ENTER button.

- ▷ **Important:**
1. You must first unlock the TV before you can use it with the timer.
  2. When you set the parental lock to "on" and the lock message appears on the screen, the TV will turn off again in about 5 minutes unless you enter the code to unlock it.
  3. The lock message appears when turning the TV on or changing a channel until you set the parental lock to "off".

### locking the TV

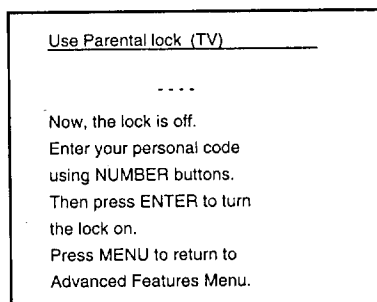

- The message for locking the TV will appear.
- Enter the secret code in four digits using the number buttons (0-9); then press the ENTER button.

You can clear the code pressing the CANCEL button.

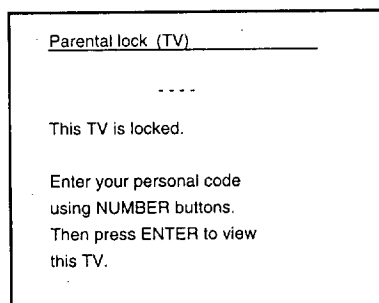

- When you set "Lock the TV" to "on," you will see a message when you next turn the television on asking you to enter your secret code.

## Using the parental lock (cont.)

### locking the channel

Use Parental lock (Channel)  
-----  
-----  
Now, the lock is off.  
Enter your personal code  
using NUMBER buttons.  
Then press ENTER to turn  
the lock on.  
Press MENU to return to  
Advanced Features Menu.

- The message for locking the channel will appear.
- Enter the secret code in four digits using the number buttons (0-9); then press the ENTER button.

You can clear the code pressing the CANCEL button.

Parental lock (Channel)  
-----  
-----  
This Channel is locked.  
  
Enter your personal code  
using NUMBER buttons.  
Then press ENTER to view  
this channel.

- When you set "Lock the channel" to "on," you will see a message when you next select the channel asking you to enter your secret code.
- Press the channel control (CHANNEL) to view an unlocked channel.

### canceling the parental lock

Use Parental lock (TV)  
-----  
-----  
Now, the lock is on.  
Enter your personal code  
using NUMBER buttons.  
Then press ENTER to turn  
the lock off.  
Press MENU to return to  
Advanced Features Menu.

- 1 Press the MENU button on the remote control. The Main Menu will appear on the screen.
- 2 Select "Advanced Features" using the ADJUST button; then press the ENTER button.
- 3 Select "Use parental lock" using the ADJUST button; then press the ENTER button.

Use Parental lock (Channel)  
-----  
-----  
Now, the lock is on.  
Enter your personal code  
using NUMBER buttons.  
Then press ENTER to turn  
the lock off.  
Press MENU to return to  
Advanced Features Menu.

- 4 Using the ADJUST button, select the lock you want to cancel; then press the ENTER button.
- 5 Enter the four digits of your secret code using the number buttons (0-9); then press the ENTER button.
- 6 Press the MENU button to return to the "Advanced Features" menu.

▷ **Important:** If you forget the Parental Lock code, please see page 89.

---

## Using the Super Quick View tuning

Super-Quick-View allows you to cycle through a list of up to ten numbers by using the SQV button. You can use the menu system to add channels to and remove channels from the list.

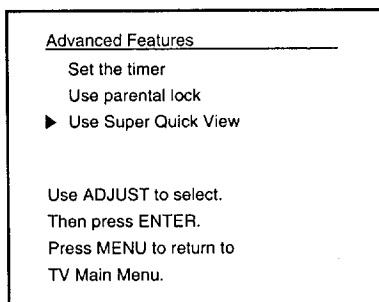

❶ Press the MENU button on the remote control. The Main Menu will appear on the screen.

❷ Select "Advanced Features" using the ADJUST button; then press the ENTER button.

❸ Select "Use Super Quick View" using the ADJUST button; then press the ENTER button.

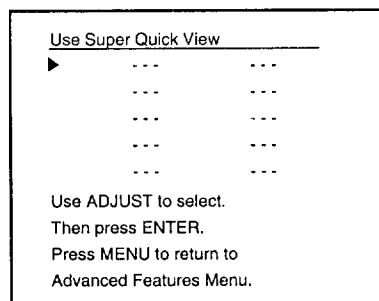

❹ Select a position to store a TV channel using the ADJUST button; then press the ENTER button.

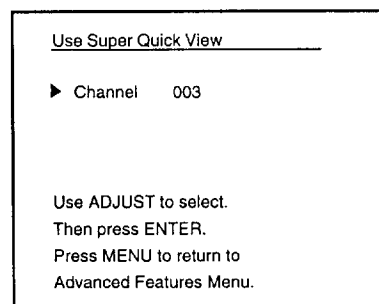

❺ Set a channel number to program into Super Quick View memory using the ADJUST button (or channel control, number buttons); then press the ENTER button.

Continue setting the channel numbers until your desired channels are programmed into Super Quick View memory.

❻ Press the MENU button to return to the "Advanced Features" menu.

▷ **Important:** You can clear each setting by pressing the CANCEL button.







## Using the Special Features

In addition to the basic and advanced functions explained in the previous chapter, this TV offers the user several special features not generally available on other brand TVs. This chapter will explain how to use these distinctive features. It contains the following topics:

- ◆ **Understanding the On-Screen Displays**
- ◆ **Using the Off-Timer**
- ◆ **Using the Picture-in-Picture (PIP) Mode**

## ◆ Understanding the On-Screen Displays

Your TV provides an on-screen summary of the current settings for the TV or cable channels, as well as the information related to Extended Data Services (XDS). XDS allows broadcasters to supply you with the current time, channel information, (such as call letters and the network name), and program information (such as the program name and program description). To view this information, press the display button (DISPLAY) on the remote control.

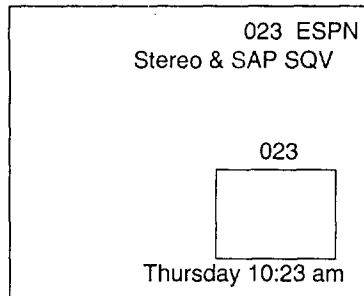

- ❶ This setting indicates the following:
- input source (channel number),
  - call letters,
  - stereo and/or SAP are available for reception on this channel,
  - this channel is programmed into super quick view memory,
  - PIP input source (when selecting PIP image),
  - current day of the week, and
  - time.

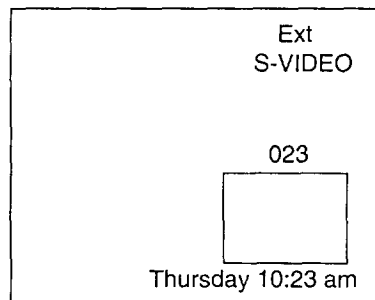

- This setting indicates the following:
- input source (Ext or input name),
  - S-VHS cable has been connected,
  - PIP input source (when selecting PIP image),
  - current day of the week, and
  - time.

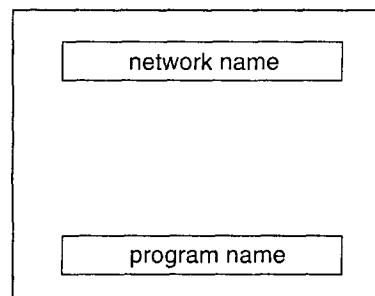

- ❷ This shows you where the network name and program name will appear if the broadcaster is supplying that information via XDS.

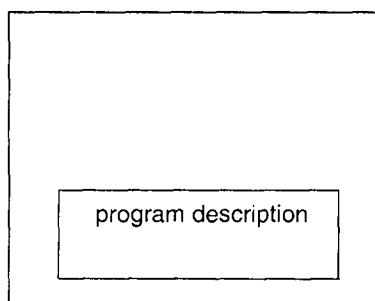

- ❸ This shows you where the program description will appear if the broadcaster is supplying that information via XDS.

▷ **Important:** If the broadcaster is not supplying information via XDS, then an explanatory message will appear ("No name available", "No description available"). Additionally, the "call letters" will not appear.

## ◆ Using the Off-Timer

---

This special function allows you to set the TV to turn off automatically. You can set the TV to turn off from 10 to 120 minutes (2 hours). In this section you'll learn:

- **Setting the off-timer, and**
- **Changing or canceling the off-timer.**

## Setting the off-timer

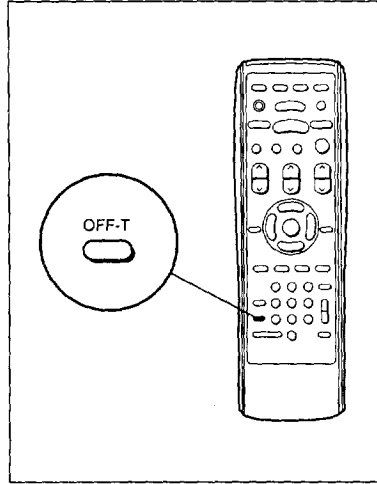

- 1 Press the off-timer button (OFF-T) on the remote control.

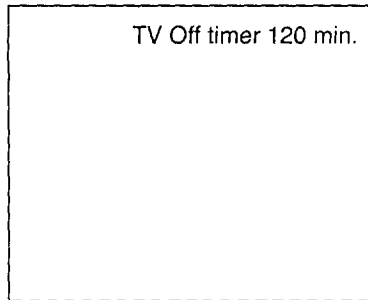

- 2 Select how long you want the TV to stay on by repeatedly pressing the off-timer button (OFF-T). The time will decrease in 10 minute intervals each time you press the button.

- 3 To view the amount of time: press the off-timer button (OFF-T) once. The on-screen display indicates "off-timer" and shows the amount of time remaining.

▷ **Important:** During the last minute before the TV is set to turn off, "Off-timer 1 min." will flash in red to remind you that the off-timer is set.

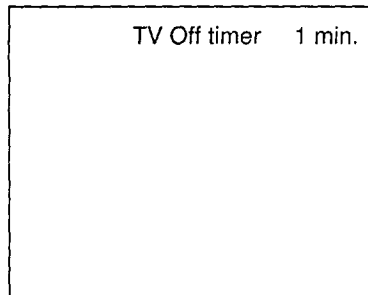

---

## Changing or canceling the off-timer

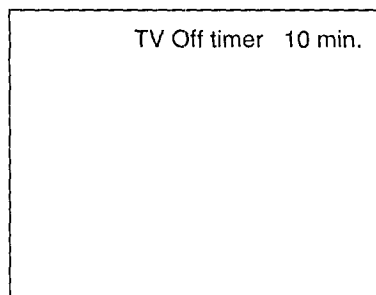

- ① Press the off-timer button (OFF-T) on the remote control. An On-screen display will indicate the amount of time remaining until the TV will turn off.
- ② Continue pressing the off-timer button (OFF-T) repeatedly to change the remaining time or cancel the off-timer. The off-timer is canceled when "---" appears instead of the remaining time.

## ◆ Using the Picture-in-Picture (PIP) Mode

---

One of the special features of the TV is the picture-in-picture (PIP) mode, which allows you to view two different sources at the same time. In this section you'll learn:

- **Selecting the PIP image,**
- **Selecting the source,**
- **Selecting the channel,**
- **Exchanging the PIP image,**
- **Moving the PIP image,**
- **Freezing the PIP image,**
- **Using the Snap-shot feature, and**
- **Using the Replay feature.**

▷ **Important:** You must have a VCR connected to the TV to see two different live action pictures when using PIP.

## Selecting the PIP image

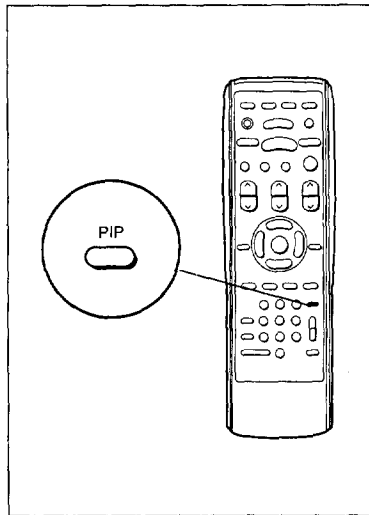

- 1 Select the number of the TV channel you want to view by using the channel control (CHANNEL).
- 2 Press the PIP button. A reduced image will appear in the bottom right corner of the screen.

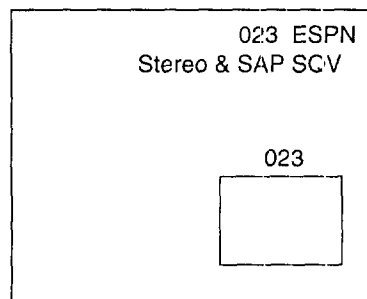

- 3 Press again; the size of the reduced image will change.

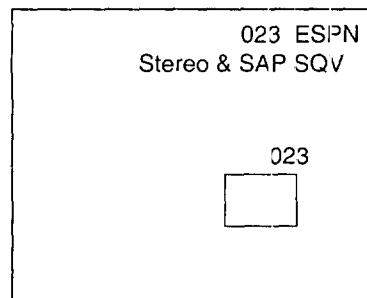

- 4 Press the PIP button once again to cancel the PIP image.

▷ **Important:** When the main image is monochrome (black and white), the PIP image will also appear in monochrome even if the PIP source is in color.

▷ **Important:** After you change the position of the reduced image, the reduced image will appear in your changed position when you select PIP again.

## Selecting the source

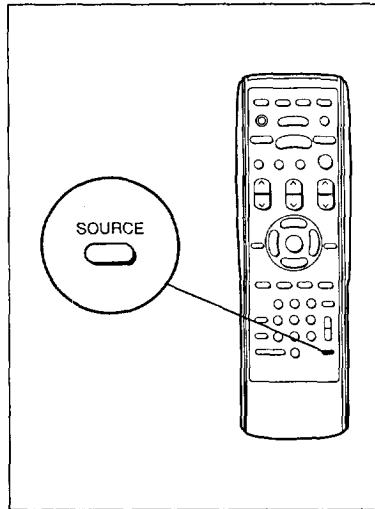

- 1 Turn your VCR on and select a channel on the VCR that is different than the channel you see on your TV screen.
- 2 Press the source button (SOURCE) on the remote control repeatedly to select the source of the PIP image: TV or External.
- 3 The PIP image will change as follows.

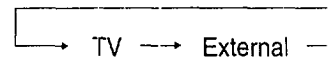

▷ **Important:** To change the background image in PIP mode, press the input button (INPUT) on the control panel or on the remote control.

## Selecting the channel

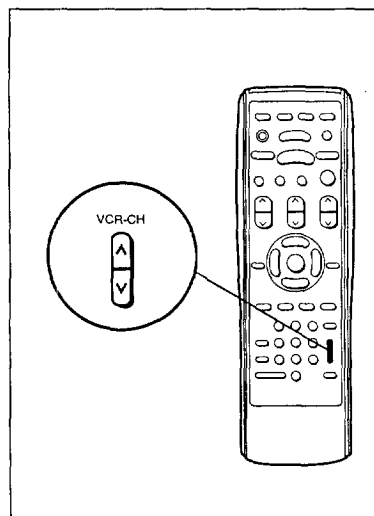

Press the PIP channel button (VCR-CH) on the remote control to change the channel of the PIP image.

▷ **Important:** When the source of the main image is the same, the PIP channel button will change the channels of both images.



## Exchanging the PIP image

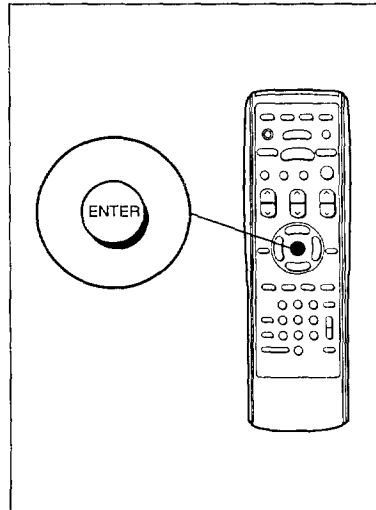

Press the enter (ENTER) button to exchange the positions of the background image and the reduced image.

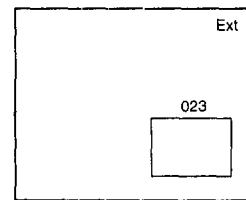
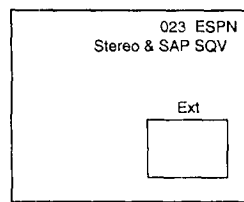

## Moving the PIP image

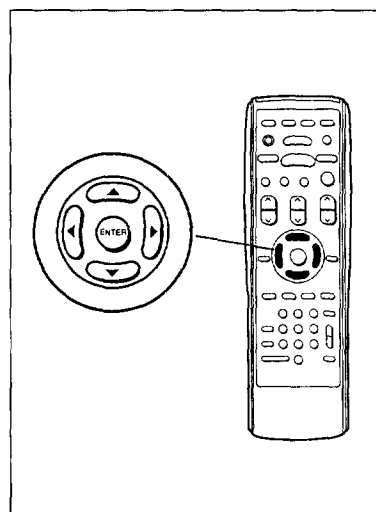

Press the adjust (up/down) button or right/left button to move the reduced image to other areas of the screen.

## Freezing the PIP image

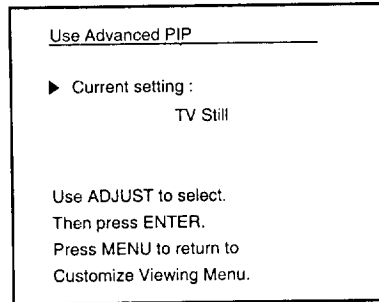

❶ Select "Use Advanced PIP" in "Customize Viewing" menu; then set the current setting to "TV Still." (See "Using the advanced PIP functions," page 60.)

❷ Use the MENU button to return to the normal picture.

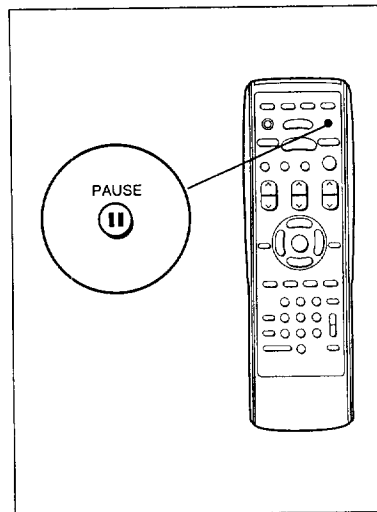

❸ Press the pause button (PAUSE) to freeze the reduced image on the screen.

❹ Press again to cancel the image freezing.

➤ **Important:** When you press the pause button while viewing the normal picture, the PIP image will appear and be frozen.

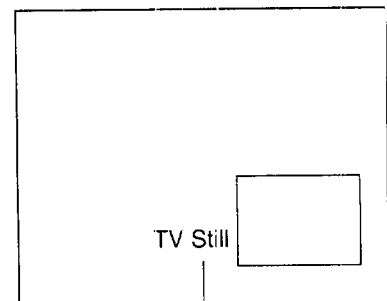

disappears after a few seconds

## Using the Snap-shot feature

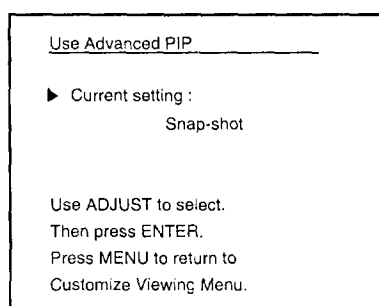

1 Select "Use Advanced PIP" in "Customize Viewing" menu; then set the current setting to "Snap-shot." (See "Using the advanced PIP functions," page 60.)

2 Use the MENU button to return to the normal picture.

3 Press the pause button (PAUSE); the frozen PIP image and the moving PIP image will appear.

4 Press the PAUSE button again; the third PIP image will appear, moving. The previous two PIP images will be frozen.

5 Each time you press the PAUSE button, the PIP images will shift upwards one by one. The top image will disappear and a frozen image appear when you press PAUSE.

6 To cancel the PIP image, press the PIP button twice.

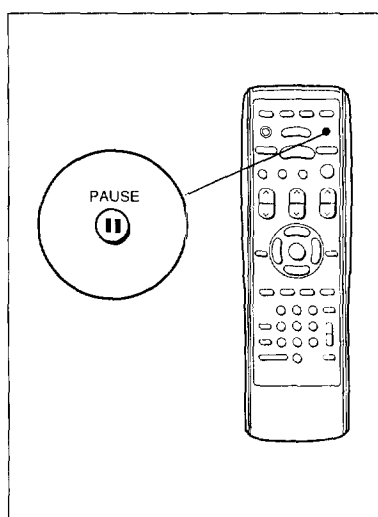

<in case of PIP off>

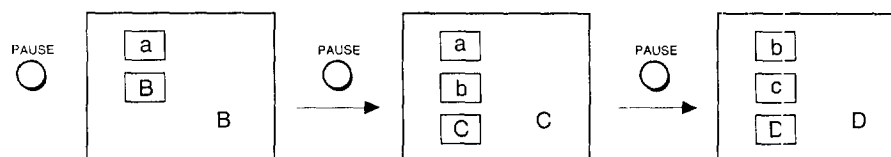

<in case of PIP on>

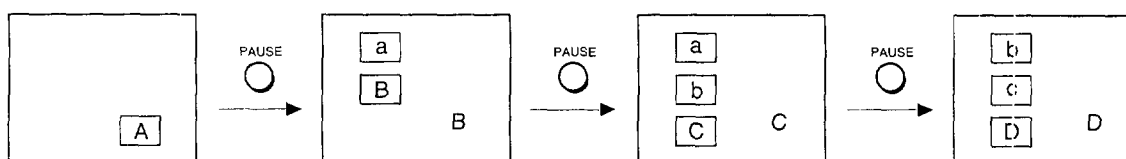

\*A, B, C, D : the moving image

\*a, b, c, d : the frozen image at the instant the PAUSE button is pressed.

## Using the Replay feature

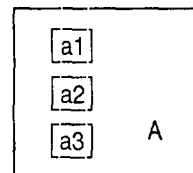
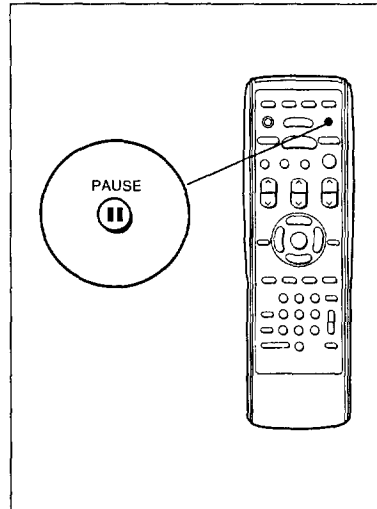
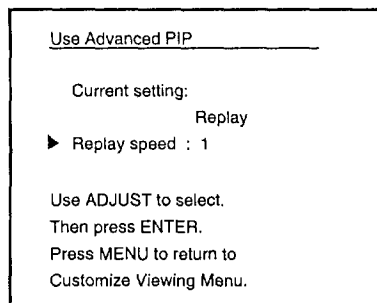
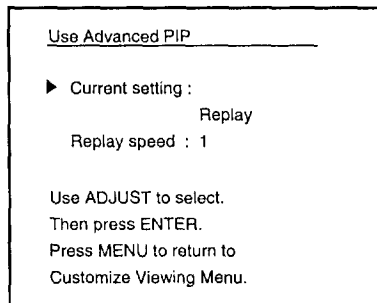

- 1 Select "Use Advanced PIP" in "Customize Viewing" menu; then set the current setting to "Replay." (See "Using the advanced PIP functions," page 60.)
- 2 Set the replay speed between 1 (short interval) and 9 (long interval).
- 3 Use the MENU button to return to the normal picture.
- 4 Press the pause button (PAUSE). The main image will be frozen and replayed in sequence for a "strobe" animation effect. These images will appear in sets of three (from a total of seven stored images) at the speed you select.
- 5 Each time you press the PAUSE button, the PIP images will shift upwards one by one.
- 6 To cancel the PIP image, press the PIP button twice.

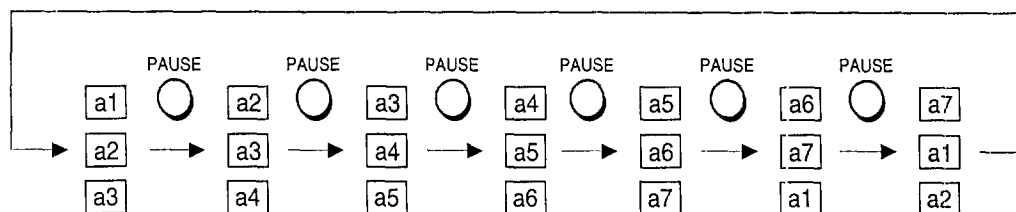



## CHAPTER 5

---

# Troubleshooting

Even though you're now familiar with the basic and advanced operations of the TV, you may run into trouble from time to time as you become accustomed to the TV. This chapter offers solutions to some of the common problems you may encounter. We suggest that you consult this chart before contacting a Mitsubishi service representative.

---

## Troubleshooting (cont.)

<b>Problems</b>	<b>Possible Solutions</b>	<b>For More Information</b>
<ul style="list-style-type: none"><li>• The remote control doesn't work.</li></ul>	<ul style="list-style-type: none"><li>• Check that the batteries are installed correctly.</li><li>• Check the select button is set to TV.</li><li>• Be sure that you are pointing the top of the remote control toward the TV from a distance of no more than 20 feet.</li></ul>	<ul style="list-style-type: none"><li>• See "Getting ready to use the remote control" in Chapter 1 for an explanation of how to install batteries in the remote control.</li><li>• See "Remote control buttons and functions" in Chapter 1, which explains where the select button is located.</li><li>• See "Getting ready to use the remote control" in Chapter 1, which contains pointers for using the remote control.</li></ul>
<ul style="list-style-type: none"><li>• The TV takes several seconds to respond to button commands.</li></ul>	<ul style="list-style-type: none"><li>• Use the ENTER button to avoid delays.</li></ul>	<ul style="list-style-type: none"><li>• See "Changing channels" in Chapter 3, which explains the function of the ENTER button.</li></ul>
<ul style="list-style-type: none"><li>• You can't access a channel.</li></ul>	<ul style="list-style-type: none"><li>• Be sure that the channel you want to view is programmed into memory.</li><li>• Check that the TV is tuned to the correct input source (antenna) for that channel.</li></ul>	<ul style="list-style-type: none"><li>• See "Memorizing channels" in Chapter 3, which explains how to program channels into the TV's memory.</li><li>• See "Selecting the input source" in Chapter 3, which explains how to change the input source.</li></ul>

---

<b>Problems</b>	<b>Possible Solutions</b>	<b>For More Information</b>
<ul style="list-style-type: none"> <li>• On-screen displays appear each time you adjust a function.</li> </ul>	<ul style="list-style-type: none"> <li>• This is part of the normal operation of the TV.</li> </ul>	<ul style="list-style-type: none"> <li>• See "Understanding the On-Screen Displays" in Chapter 4 for a full explanation of the on-screen displays.</li> </ul>
<ul style="list-style-type: none"> <li>• There's no sound even when the volume is turned up.</li> </ul>	<ul style="list-style-type: none"> <li>• Check that the MUTE button isn't on.</li> <li>• Check the setting of the "Speaker: ON/OFF" function.</li> </ul>	<ul style="list-style-type: none"> <li>• See "Remote control buttons and functions" in Chapter 1, which explains the location and function of the MUTE button.</li> <li>• See "Adjusting the sound" in Chapter 3, which explains how to turn the built-in speakers on and off.</li> </ul>
<ul style="list-style-type: none"> <li>• You forget the code you used to set the parental lock.</li> </ul>	<ul style="list-style-type: none"> <li>• Use the alternate procedure that doesn't require the use of the code.</li> </ul>	<ul style="list-style-type: none"> <li>• See the Appendix, "Procedure for Bypassing the Parental Lock."</li> </ul>
<ul style="list-style-type: none"> <li>• You can't program the TV to turn on automatically.</li> </ul>	<ul style="list-style-type: none"> <li>• The TV may be locked.</li> </ul>	<ul style="list-style-type: none"> <li>• See "Using the parental lock" of "Using the Advanced Features" in Chapter 3.</li> </ul>
<ul style="list-style-type: none"> <li>• The sound doesn't match the image on screen.</li> </ul>	<ul style="list-style-type: none"> <li>• The TV's reception mode may be set to "separate audio program (SAP)."</li> </ul>	<ul style="list-style-type: none"> <li>• See "Adjusting the sound" in Chapter 3, which explains how to select the appropriate reception mode.</li> </ul>

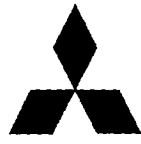

## CHAPTER 5

---

# Troubleshooting

Even though you're now familiar with the basic and advanced operations of the TV, you may run into trouble from time to time as you become accustomed to the TV. This chapter offers solutions to some of the common problems you may encounter. We suggest that you consult this chart before contacting a Mitsubishi representative.



## Calling for service

If you are unable to correct the problem, consult your MITSUBISHI dealer or MITSUBISHI Authorized Warranty Service Center.

Do not adjust any controls not described in this owner's guide.

Do not remove the protective back cover of this unit.

If you see the following display on your screen, you should not change any settings. This is a special display used by the factory.

▶ Initial	System1A : Off
E2RESET	CCD : On
Hotel : Off	Auto clock : On
	Call letr. : On
PIP : On	Net name : On
	Prog name : On
Montr. fix : Off	Prog descr : On
Auto turn : Off	
Antenna : 1	
Input : 1	

If this display appears, make sure that all of the on/off settings are the same as the illustration above and then turn the TV off. If any of the settings are different than the illustration above, turn the TV off and consult your MITSUBISHI dealer or MITSUBISHI Authorized Warranty Service Center.





Cut along dotted line and file after reading

89

After you lock the TV, you will need the secret code in order to:

- ① view the locked TV, or
- ② cancel the lock.

If you forget the code, you can view the locked TV without entering the code. To do this, simply press the buttons labeled "QV" and "9" at the same time.

▷ **Important:** This procedure will only unlock the TV temporarily. To cancel the lock completely, follow the procedure below:

- ① Press the "QV" button and the "9" button on the remote control at the same time. This will allow you to turn on a locked TV.
- ② Press the MENU button to view the main menu. Use the ADJUST button to select "Advanced Features." Press ENTER.
- ③ Use the ADJUST button to select "Lock the TV." Press ENTER.
- ④ Press the "QV" button and the "9" button on the remote control at the same time. This will turn off the lock.



**A**

- Adding and deleting channels 55
- adjust (up/down) buttons 22, 23
- Adjusting the color purity 41
- Adjusting the picture 63
  - adjusting the brightness
  - adjusting the color
  - adjusting the sharpness
  - adjusting the tint
  - changing the color temperature
  - changing the contrast
  - setting closed captioning
- Adjusting the sound 61
  - adjusting the balance
  - adjusting the bass
  - adjusting the treble
  - setting the reception mode
  - setting the surround mode
  - turning the speaker on/off
- antenna terminal 26
- audio and VCR buttons 21
- audio and video controls 21
- audio function button (AUDIO) 21
- audio input terminals 26
- audio output terminals 26
- Automatic Procedure for the Parental Lock 89
- A/V reset button (A/V RESET) 17

**B**

- Basic Connections 27
  - TV+antenna or cable with a decoder box 29
  - TV+antenna or cable without a decoder box 28
  - TV+audio system 37
  - TV+separate UHF and VHF antennas 30
  - TV+VCR+antenna or cable with a decoder box 34
  - TV+VCR+antenna or cable without a decoder box 31

**C**

- Calling for Service 87
- cancel button (CANCEL) 22
- Caution and Care 86
- Changing channels 48
- Changing or canceling the off-timer 75
- channel controls (CH, CHANNEL) 17, 21
- color purity adjustment switches 17
- Connecting Your TV 25
  - Basic connections 27
  - Overview of the Back Panel 26

**D**

- degauss button (DEGAUSS) 17
- Deleting channels 55
- display button (DISPLAY) 22

**E**

- enter button (ENTER) 21

**F**

- Freezing the PIP image 80

**G**

- Getting ready to use the remote control 18
  - general instructions 19
  - guidelines for using batteries 19
  - installing the batteries 18
  - some dos and don'ts 19
- Getting Started 40
  - Adding and deleting channels 55
  - Adjusting the color purity 41
  - Adjusting the picture 63
  - Adjusting the sound 61
  - Changing channels 48
  - Memorizing channels 54
  - Renaming the inputs 56
  - Selecting the input source 47

- Selecting language 57

- Setting the clock 52

- Turning the TV on/off 46

- Understanding the on-screen menus 51

- Using the advanced PIP functions 60

- Using the closed caption decoder 64

- Using the power restore feature 59

- Using the remote control 42

- Using video mute 58

- Getting to Know Your TV 15

- Overview of the Control Panel 16

- Overview of the Remote Control 18

**H**

- home button (HOME) 22

**I**

- Important Safeguards 3

- input button (INPUT) 17, 21

- installing the batteries 18

**M**

- Memorizing channels 54

- menu button (MENU) 22

- Moving the PIP image 79

- mute control (MUTE) 21

**N**

- number buttons 22

**O**

- off timer button (OFF-T) 22

- Operating Your TV 39

- Getting Started 40

- Using the Advanced Features 65

- Overview of the Back Panel 26

- Overview of the Control Panel 16

- Overview of the Remote control 18

Getting ready to use the remote control 18  
Remote control buttons and functions 20

## **P**

picture-in-picture controls 23  
power button (POWER) 16, 21  
program timer indicator (PROGRAM TIMER) 17

## **Q**

quick view button (QV) 21

## **R**

Renaming the inputs 56  
Remote control buttons and functions 20  
right/left buttons 22, 23

## **S**

select buttons 21  
Selecting language 57  
Selecting the channel (PIP mode) 78  
Selecting the PIP image 77  
Selecting the input source 47  
Selecting the source (PIP mode) 78  
Setting the clock 52  
Setting the off-timer 74  
Setting the timer 66  
Some Conventions Used in This Guide 13  
Summary of Special Features 10  
super quick view button (SQV) 21  
S-VIDEO input terminal 26

## **T**

Troubleshooting 83  
    Calling for Service 87  
    Caution and Care 86  
Turning the TV on/off 46  
TV+antenna or cable with a decoder box 29

TV+antenna or cable without a decoder box 28  
TV+audio system 37  
TV+separate UHF and VHF antennas 30  
TV+VCR+antenna or cable with a decoder box 34  
TV+VCR+antenna or cable without a decoder box 31

## **U**

Unpacking Your TV 11  
Understanding the On-Screen Displays 72  
Understanding the on-screen menus 51  
Using the advanced PIP functions 60  
Using the Advanced Features 65  
    Setting the timer 66  
    Using the parental lock 67  
    Using the Super Quick View tuning 69  
Using the closed caption decoder 64  
Using the Off-Timer 73  
    Changing or canceling the off-timer 75  
    Setting the off-timer 74  
Using the parental lock 67  
Using the Picture-in-Picture (PIP) Mode 76  
    Freezing the PIP image 80  
    Moving the PIP image 79  
    Selecting the channel 78  
    Selecting the PIP image 77  
    Selecting the source 78  
    Using the Replay feature 82  
    Using the Snap-shot feature 81  
Using the power restore feature 59  
Using the remote control 42  
Using the Replay feature 82  
Using the Snap-shot feature 81

Using the Special Features  
    Understanding the On-Screen Displays 72  
    Using the Off-Timer 73  
    Using the Picture-in-Picture (PIP) Mode 76  
Using the Super Quick View tuning 69  
Using video mute 58

## **V**

video function button (VID) 22  
video input terminal 26  
video output terminal 26  
volume controls (VOL, VOLUME) 16, 21

## **W**

What's in Each Chapter 12

**MITSUBISHI COLOR TELEVISION OR COLOR MONITOR  
LIMITED WARRANTY**

MITSUBISHI ELECTRONICS AMERICA, INC. ("MELA") warrants to the original purchaser of this television that if purchased from an authorized MITSUBISHI Audio/Video Dealer, should it prove defective by reason of improper workmanship and/or material:

- a. **Picture Tube.** For two years from the date of original purchase at retail, we will repair or replace at our option, any defective picture tube without charge for the tube.
- b. **Other Parts.** For one year from the date of original purchase at retail, we will repair or replace, at our option, any other defective part without charge for the part.
- c. All parts used for replacement are warranted for the remainder of the original warranty period.
- d. **Labor.** For one year from the original purchase at retail, we will provide the labor for a warranty repair by an authorized MITSUBISHI service center without charge.
- e. **Notice.** To obtain warranty service, you must notify an authorized MITSUBISHI service center of any defect within the applicable warranty time period.

**1. TO OBTAIN WARRANTY SERVICE DURING THE FIRST YEAR:**

a. Contact your nearest authorized MITSUBISHI service center whose name and address can be obtained from your MITSUBISHI dealer or by writing or calling MELA at the address and telephone number provided below.

b. Warranty service will be provided in your home or, if required, at an authorized service shop, provided that your television is located within the geographic territory customarily covered by an authorized MITSUBISHI service center. If not, you must either deliver your television to an authorized service location at your own expense, or pay for any travel and/or transportation costs the service center may charge to and from your home. Actual service labor will be provided without charge.

c. Proof of purchase date from an authorized Mitsubishi dealer is required when requesting warranty service. Present your sales receipt or other document which establishes proof and date of purchase. **THE RETURN OF THE OWNER REGISTRATION CARD IS NOT A CONDITION OF WARRANTY COVERAGE.** However, please detach and return the Owner Registration Card so that we can contact you should a question of safety arise which could affect you.

2. **AFTER THE FIRST YEAR,** to obtain warranty service for a defective picture tube, you are responsible for delivering the television or monitor to an authorized MITSUBISHI service center at your own expense.

3. **THIS WARRANTY DOES NOT COVER** damage caused by: modification, alteration, repair or service of the product by anyone other than an authorized MITSUBISHI service center; physical abuse to, or misuse of, the product; operation in a manner contrary to the instructions which accompany the product; freight damage; or any damage caused by acts of God such as lightning or fluctuation in electrical power. This warranty also excludes all costs arising from installation, adjustment of user controls, external antenna systems, service of products purchased or serviced outside the U.S.A., initial technical adjustments (set-up) and user-required maintenance. Consult the operating instructions furnished with the product for information regarding user controls.

4. **ANY EXPRESS WARRANTY NOT PROVIDED HEREIN, AND ANY REMEDY WHICH, BUT FOR THIS PROVISION, MIGHT ARISE BY IMPLICATION OR OPERATION OF LAW, IS HEREBY EXCLUDED AND DISCLAIMED.** THE IMPLIED WARRANTIES OF MERCHANTABILITY AND OF FITNESS FOR ANY PARTICULAR PURPOSE ARE EXPRESSLY LIMITED TO A TERM OF ONE YEAR.

5. **UNDER NO CIRCUMSTANCES SHALL MELA BE LIABLE TO PURCHASER OR ANY OTHER PERSON FOR ANY INCIDENTAL, SPECIAL OR CONSEQUENTIAL DAMAGES, WHETHER ARISING OUT OF BREACH OF WARRANTY, BREACH OF CONTRACT, OR OTHERWISE.**

6. Some states do not allow limitation on how long an implied warranty lasts, or the exclusion or limitation of incidental, special, or consequential damages, so the above limitations or exclusions may not apply to you.

7. This warranty gives you specific legal rights, and you may also have other rights which vary from state to state.

8. **BEFORE REQUESTING SERVICE,** please review the instruction booklet to insure proper installation and correct customer control adjustment. If the problem persists, contact your nearest MITSUBISHI Dealer for name(s) of authorized MITSUBISHI Service Center(s). If you are unable to obtain this information, please call 800-332-2119, or write us at the address below.

**MITSUBISHI ELECTRONICS AMERICA, INC.**  
P.O. Box 5025  
Norcross, GA 30091-5025



**RETAIN THIS PORTION FOR YOUR RECORDS.**

MODEL NO. \_\_\_\_\_  
SERIAL NO. \_\_\_\_\_

CUSTOMER NAME \_\_\_\_\_

STREET ADDRESS \_\_\_\_\_

CITY \_\_\_\_\_ STATE \_\_\_\_\_ ZIP \_\_\_\_\_

PHONE (\_\_\_\_\_) - \_\_\_\_\_ PURCHASE DATE \_\_\_\_/\_\_\_\_/\_\_\_\_  
A/C M/D DAY YR

PLACE OF PURCHASE \_\_\_\_\_



**MITSUBISHI ELECTRONICS AMERICA, INC.**  
6100 Atlantic Boulevard  
Norcross, GA 30071-1305