

**SONY®**

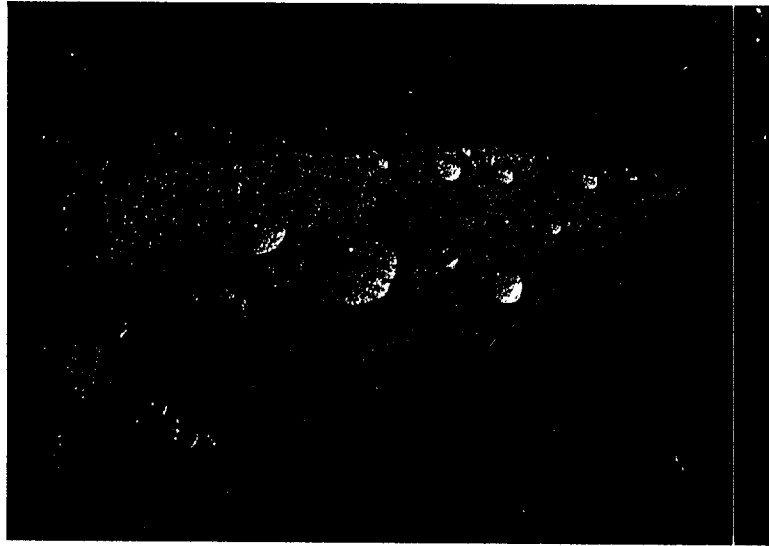

# ***Color Rear Video Projector***

---

Operating Instructions \_\_\_\_\_ **EN**

Manual de instrucciones \_\_\_\_\_ **ES**

***KP-53XBR4CT***

©1996 by Sony Corporation

# WARNING

**To prevent fire or shock hazard, do not expose the unit to rain or moisture.**

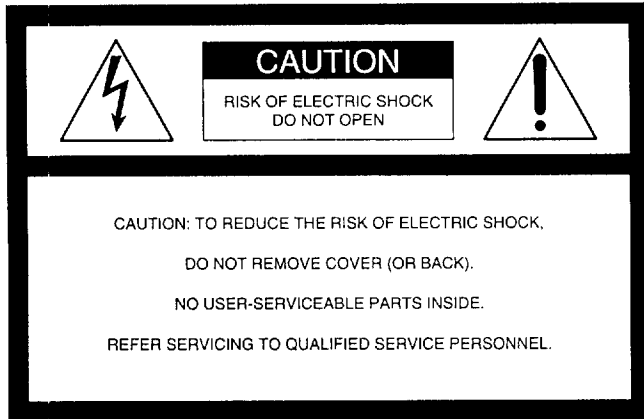

This symbol is intended to alert the user to the presence of uninsulated "dangerous voltage" within the product's enclosure that may be of sufficient magnitude to constitute a risk of electric shock to persons.



This symbol is intended to alert the user to the presence of important operating and maintenance (servicing) instructions in the literature accompanying the appliance.

## CAUTION

TO PREVENT ELECTRIC SHOCK, DO NOT USE THIS POLARIZED AC PLUG WITH AN EXTENSION CORD, RECEPTACLE OR OTHER OUTLET UNLESS THE BLADES CAN BE FULLY INSERTED TO PREVENT BLADE EXPOSURE.

## CAUTION

When using projection TV games, computers, and similar products with your projection TV, keep the brightness and contrast functions at low settings. If a fixed (non-moving) pattern is left on the screen for long periods of time at a high brightness or contrast setting, the image can be permanently imprinted onto the screen. These types of imprints are not covered by your warranty because they are the result of misuse.

## NOTIFICATION

This equipment has been tested and found to comply with the limits for a Class B digital device pursuant to Part 15 of the FCC Rules. These limits are designed to provide reasonable protection against harmful interference in a residential installation. This equipment generates, uses, and can radiate radio frequency energy and, if not installed and used in accordance with the instructions, may cause harmful interference with radio communications. However, there is no guarantee that interference will not occur in a particular installation. If this equipment does cause harmful interference to radio or television reception, which can be determined by turning the equipment off and on, the user is encouraged to try to correct the interference by one or more of the following measures:

- Reorient or relocate the receiving antennas.
- Increase the separation between the equipment and receiver.
- Connect the equipment into an outlet on a circuit different from that to which the receiver is connected.
- Consult the dealer or an experienced radio/TV technician for help.

You are cautioned that any changes or modifications not expressly approved in this manual could void your authority to operate this equipment.

This document is for the remote commander RM-Y128.  
MODELS: KP-53XBR4CT

Please keep this notice with the instruction manual.

## Note on Closed Caption (Caption Vision)

This television receiver provides display of television closed captioning in accordance with §15.119 of the FCC rules.

## Note on CATV system installer

This reminder is provided to call the CATV system installer's attention to Article 820-40 of the NEC that provides guidelines for proper grounding and, in particular, specifies that the cable ground shall be connected to the grounding system of the building, as close to the point of cable entry as practical.

Use of this television receiver for other than private viewing of programs broadcast on UHF or VHF or transmitted by cable companies for the use of the general public may require authorization from the broadcaster/cable company and/or program owner.

## Trademark

DBS® is a registered trademark of DIRECTV, Inc., a unit of Hughes Electronics Corporation.

---

## Owner's Record

The model and serial numbers are located at the rear of the projection TV. Record these numbers in the spaces provided below. Refer to them whenever you call upon your Sony dealer regarding this product.

Model No. KP-53XBR4CT

Serial No. \_\_\_\_\_

# Table of contents

- 4 Welcome!
- 4 Precautions

---

## Getting Started

- 5 Step 1: Installing the projection TV
- 6 Step 2: Connections
  - 6 Connecting an antenna
  - 6 Connecting an antenna/cable TV system without a VCR
  - 7 Connecting an antenna/cable TV system with a VCR
  - 9 Connecting a DBS® receiver
  - 10 Connecting a camcorder
  - 10 Connecting two VCRs for tape editing
  - 11 Connecting an audio system
  - 11 Connecting an amplifier with Dolby Pro Logic decoder
  - 12 Connecting an AV receiver
  - 12 Connecting other Sony equipment with the CONTROL S jacks
- 13 Step 3: Setting up the remote commander
  - 13 Inserting batteries
  - 13 Using the joystick remote commander for menu operation
- 14 Step 4: Setting up the projection TV automatically (AUTO SET UP)
  - 15 Erasing or adding channels
  - 16 Adjusting convergence (CONVERGENCE)
  - 16 Setting cable TV on or off
  - 17 Presetting channels
  - 17 Changing the menu language
- 18 Selecting the cable box output channel (TV INPUT)

---

## Operations

- 19 Watching the TV
  - 19 Switching quickly between two channels
  - 20 Muting the sound
  - 20 Displaying on-screen information
  - 20 Freezing the picture
  - 20 Setting the Sleep Timer
  - 21 Watching a video input picture
  - 21 Changing the VHF/UHF input to the AUX input

- 21 Watching two programs at one time—PIP/P&P (Twin View™)
  - 21 Displaying a window picture (PIP)
  - 22 Displaying a left picture (P&P)
  - 22 Changing the window/left picture input mode
  - 22 Changing TV channels in the window/left picture
  - 22 Listening to the sound of the window/left picture
  - 22 Changing the position of the window picture
  - 22 Swapping the main/right and window/left pictures
  - 23 Freezing the pictures
  - 23 Watching eight TV channels at one time (CH INDEX)
- 23 Using the VIDEO menu
  - 23 Adjusting the picture (VIDEO)
  - 24 Adjusting the color temperature (TRINITONE)
  - 24 Reducing picture noise (NR)
  - 25 Enhancing the picture contrast (DYNAMIC PICTURE)
  - 25 Correcting the color (COLOR CORRECTION)
- 26 Using the AUDIO menu
  - 26 Adjusting the sound (AUDIO)
  - 27 Selecting stereo or bilingual programs (MTS)
  - 27 Setting the speaker switch (SPEAKER)
- 28 Using the PROGRAM PALETTE menu
  - 28 Selecting picture effect (PROGRAM PALETTE)
  - 28 Adjusting the picture in PROGRAM PALETTE
- 29 Using the INPUT/OUTPUT menu
  - 29 Selecting an output signal (INPUT/OUTPUT)
  - 30 Setting video labels (VIDEO LABEL)
- 30 Using the TIMER menu
  - 30 Setting the clock (CURRENT TIME)
  - 32 Setting your daylight saving time (DS TIME)
  - 32 Setting the timer to turn the projection TV on and off (ON/OFF TIMER)
  - 33 Blocking out a channel (CHANNEL BLOCK)
- 34 Using the SET UP menu
  - 34 Customizing the channel names (CH CAPTION/LOGO)
  - 36 Setting your favorite channels (FAVORITE CHANNEL)
  - 36 Selecting a favorite channel
  - 37 Selecting a VCR input directly (DIRECT PLAY)
  - 37 Customizing the pointer (CUSTOMIZED POINTER)
- 38 Displaying Caption Vision/XDS (CAPTION VISION/XDS)
- 40 Operating video equipment
- 41 Operating a cable box or DBS receiver
- 42 Operating non-preprogrammed equipment—Learning function

---

## Additional Information

- 43 Troubleshooting
- 45 Specifications
- 46 Index

The captions in parentheses indicate menu names.

# Welcome!

Thank you for purchasing the Sony Color Rear Video Projection TV. Here are some of the features you will enjoy with your projection TV:

- AUTO SET UP feature that allows you to set up your TV easily by pressing the SET UP button.
- On-screen graphic menus that let you visually set various settings.
- Two tuner Picture-in-Picture or Picture & Picture (Twin View™) that allows you to watch another channel, video or cable image as a window or left picture.
- On/off timer that allows you to display the TV program of your choice on the screen for a specified duration.
- Dynamic Focus circuitry that automatically focuses the scanning electron beam for enhanced sharpness, especially at the corners.
- The supplied joystick remote commander that allows you to operate Sony and other manufacturers' video equipment, cable box and DBS receiver. The Learning function of the commander allows you to program the remote commander to operate the equipment of manufacturers whose codes are not pre-programmed.
- 3-Dimensional Comb Filter for NTSC signals that improve picture quality by reducing rainbow noise on a striped image and flicker which may be caused by color variation.
- XDS (Extended Data Service) display that allows you to receive various information which a broadcaster offers with a program.
- Favorite channel feature that allows you to watch eight channels as well as the currently selected channel at the same time and lets you select your favorite channel among them.

## About the keys on the control panel of the projection TV

Instructions in this manual are based on use of the remote commander. You can also use the keys on the projection TV if they have the same name as those on the remote commander. When you use the keys on the projection TV, press the CONTROL key on the projection TV to illuminate the keys on the control panel.

# Precautions

This projection TV operates on extremely high voltage. To prevent fire or electric shock, please follow the precautions below.

## Safety

- Operate the projection TV only on 120 V AC.
- One blade of the plug is wider than the other for safety purposes and will fit into the power outlet only one way. If you are unable to insert the plug fully into the outlet, contact your dealer.
- Should any liquid or solid object fall into the cabinet, unplug the projection TV and have it checked by qualified personnel before operating it further.
- Unplug the projection TV from the wall outlet if you are not going to use it for several days or more. To disconnect the cord, pull it out by the plug. Never pull the cord itself.

For details concerning safety precautions, see the supplied leaflet "IMPORTANT SAFEGUARDS."

## Installing

- To prevent internal heat build-up, do not block the ventilation openings.
- Do not install the projection TV in a hot or humid place, or in a place subject to excessive dust or mechanical vibration.
- Avoid operating the projection TV at temperatures below 5°C (41°F).
- If the projection TV is transported directly from a cold to a warm location, or if the room temperature has changed suddenly, the picture may be blurred or show poor color. This is because moisture has condensed on the mirror or lenses inside. If this happens, let the moisture evaporate before using the projection TV.
- To obtain the best picture, do not expose the screen to direct illumination or direct sunlight. It is recommended to use spot lighting directed down from the ceiling or to cover the windows that face the screen with opaque drapery. It is desirable to install the projection TV in a room where the floor and walls are not of reflecting material. If necessary, cover them with dark carpeting or wall paper.

## Note on cleaning

Clean the cabinet of the projection TV with a dry soft cloth. To remove dust from the screen, wipe it gently with a soft cloth. Stubborn stains may be removed with a cloth slightly dampened with a solution of mild soap and warm water. Never use strong solvents such as thinner or benzine for cleaning.

If the picture becomes dark after using the projection TV for a long period of time, it may be necessary to clean the inside of the projection TV. Consult qualified service personnel.

# Step 1: Installing the projection TV

For the best picture quality, install the projection TV within the areas shown below. For details on installation, see the Installation Manual.

## Optimum viewing area (Horizontal)

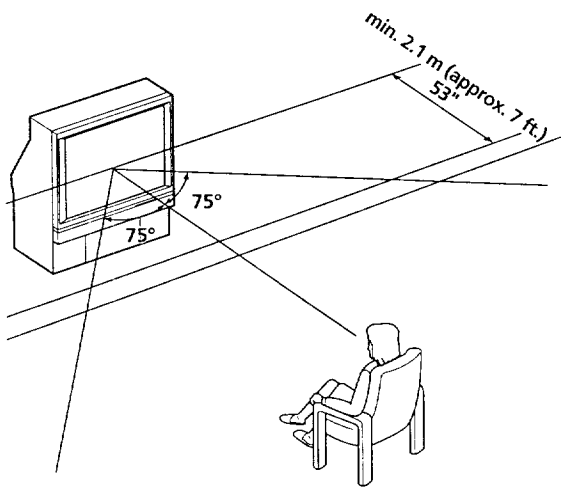

## Optimum viewing area (Vertical)

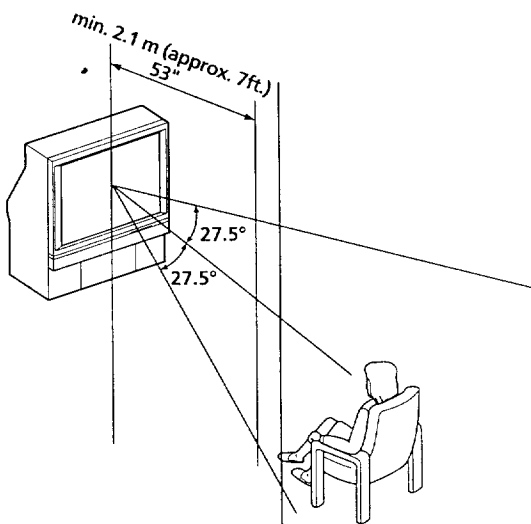

## Preparing for your projection TV

Before you use your projection TV, adjust convergence. For the procedure, see "Adjusting convergence (CONVERGENCE)" on page 16.

# Step 2: Connections

Although you can use either an indoor antenna or outdoor antenna with your projection TV, we recommend connecting to an outdoor antenna or a cable TV system for improved picture quality.

For the customers who connect a cable box, skip "Step 4: Setting up the projection TV automatically (AUTO SET UP)" (page 14) and proceed to "Selecting the cable box output channel (TV INPUT)" (page 18).

## Connecting an antenna

Connect your antenna cable to the VHF/UHF antenna terminal. If you cannot connect your antenna cable directly to the terminal, follow one of the instructions below depending on your cable type.

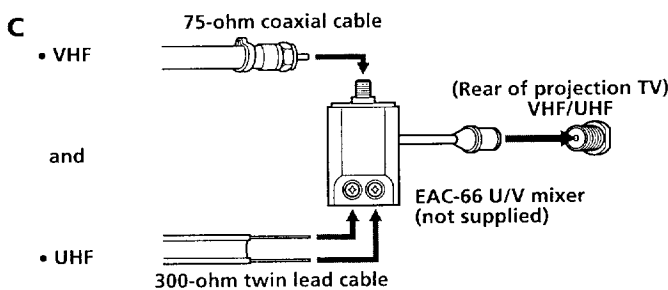
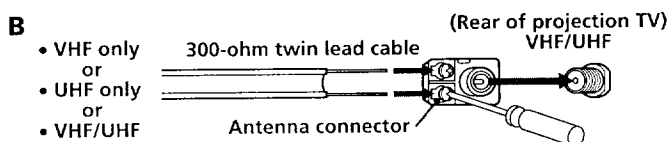
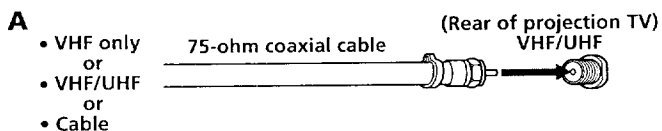

### Notes

- Most VHF/UHF combination antennas have a signal splitter. Remove the splitter before attaching the appropriate connector.
- For better picture quality, connect an antenna by using a 75-ohm coaxial cable.

## Connecting an antenna/cable TV system without a VCR

### To cable or antenna

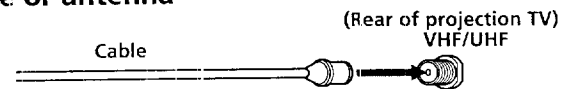

### To cable box

If your cable company requires you to connect a cable box, make the connection as follows:

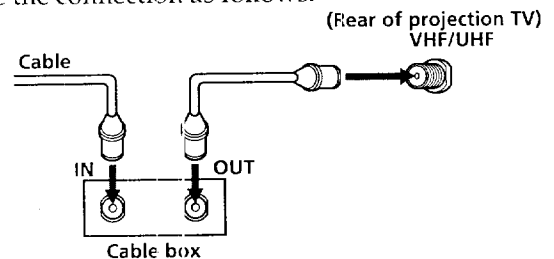

### To cable box and cable

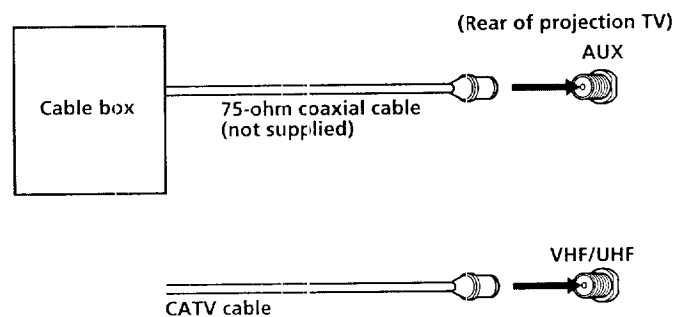

Some cable TV systems use scrambled or encoded signals requiring a cable box\* in addition to the normal cable connection.

\* The cable box will be supplied by the cable company.

### To cable and antenna

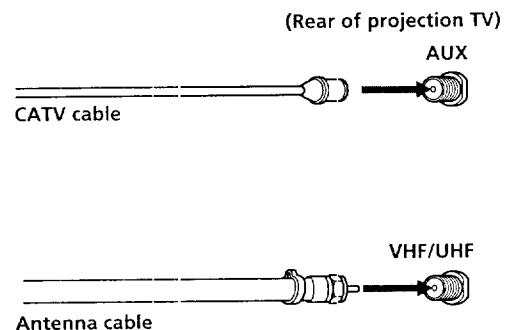

## Connecting an antenna/cable TV system with a VCR

For connection details, see the instruction manual of your VCR. Before connecting, disconnect the AC power cords of the equipment to be connected.

After making these connections, you will be able to do the following:

- View the playback of video tapes
- Record one TV program while viewing another program

### To a conventional VCR

#### Without a cable box

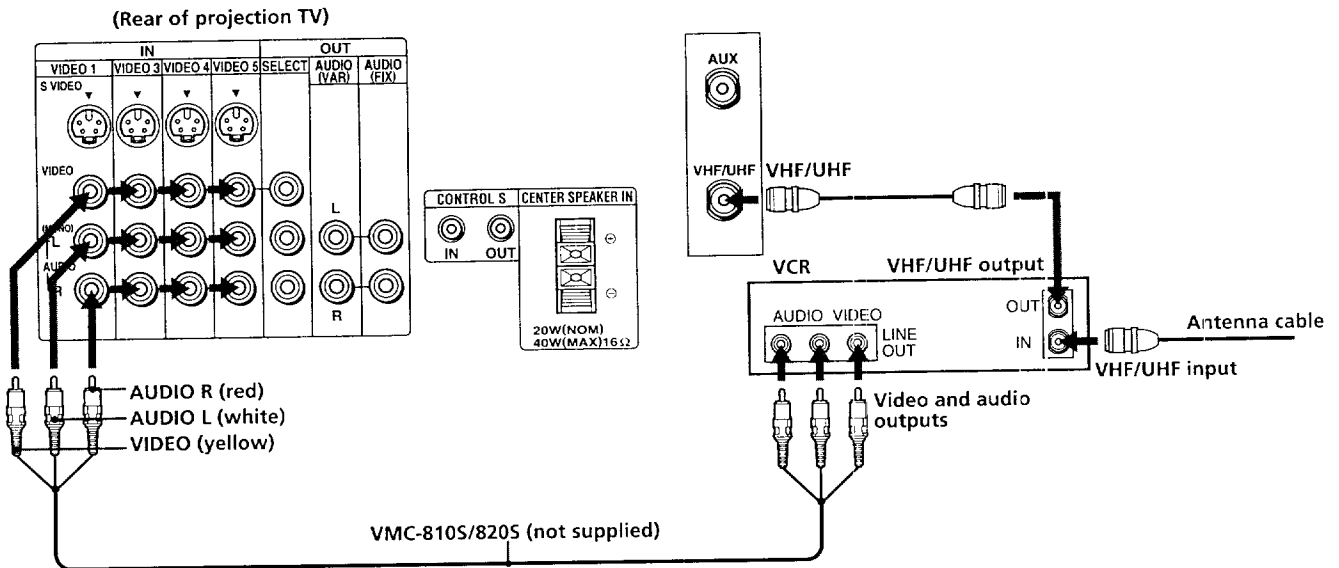

#### Notes

- To connect a monaural VCR, connect the audio output of the VCR to AUDIO L (MONO) of VIDEO 1/3/4/5 IN on the projection TV.
- Do not connect a cable to the S VIDEO connector on the projection TV.

#### With a cable box

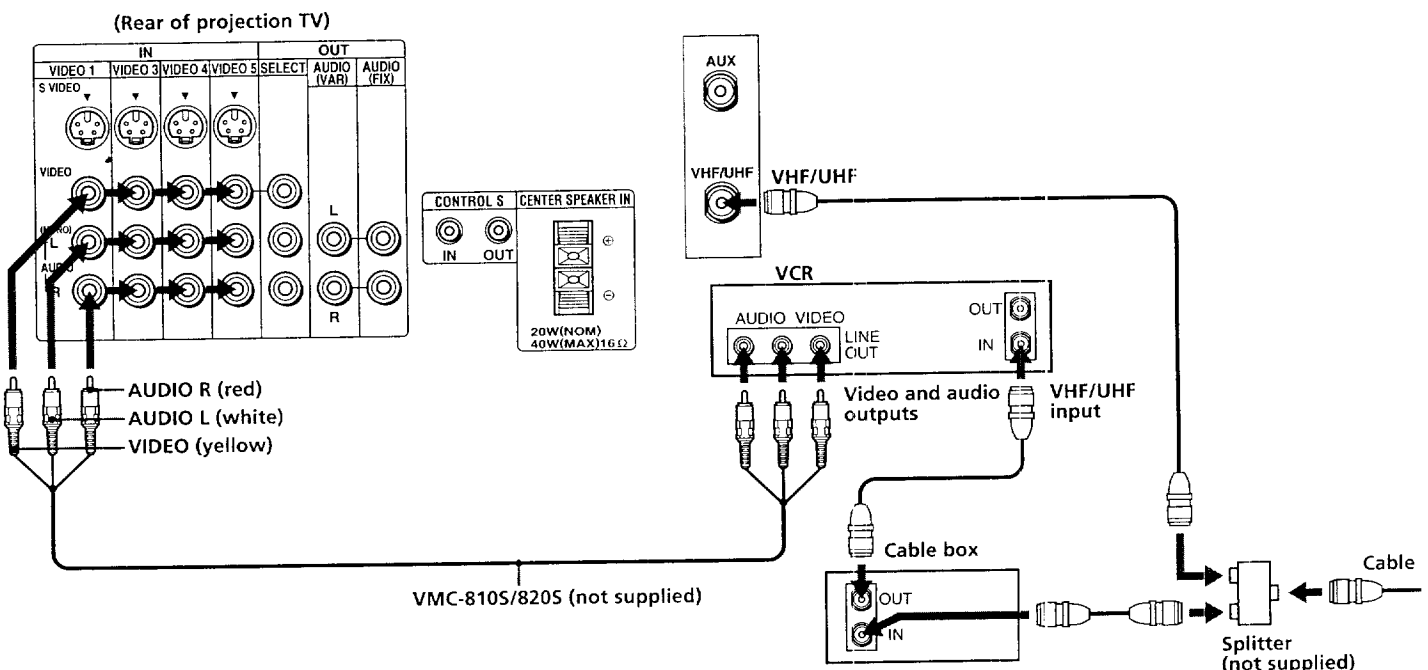

## To an S video equipped VCR

If your VCR has an S video output jack, make the connection as follows. Whenever you connect a cable to the S VIDEO connector, the projection TV automatically receives S video signals.

### Without a cable box

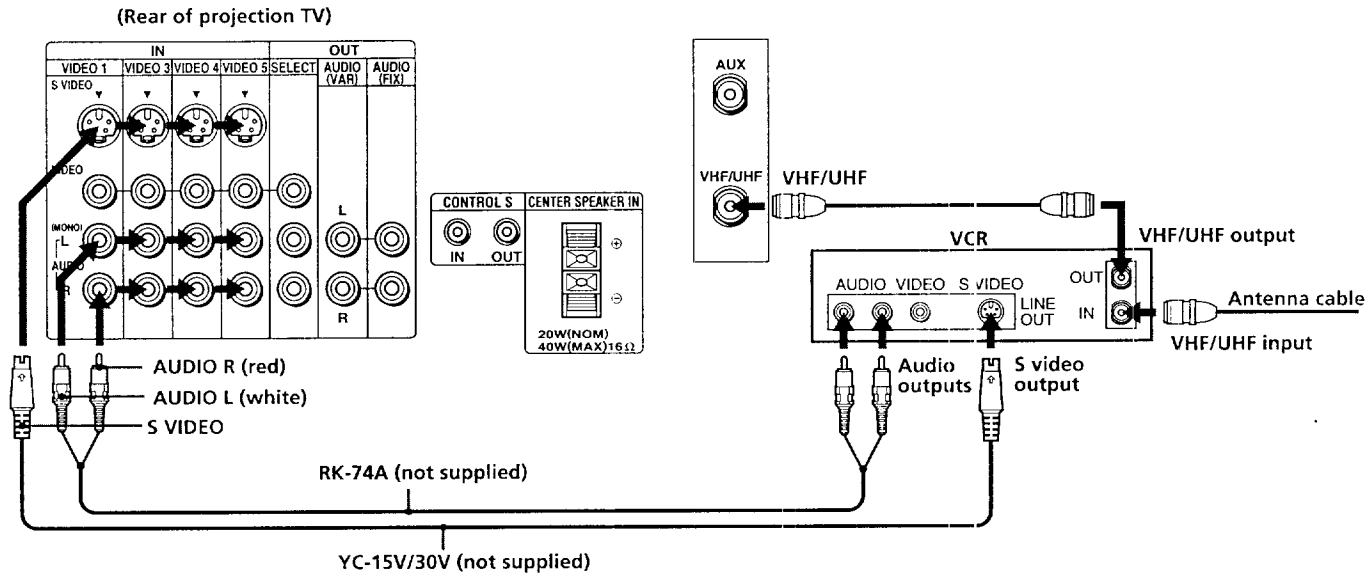

### Note

- Video signals are composed of Y (luminance) and C (chroma) signals. The S connection sends the two signals separately preventing degradation, and gives better picture quality compared to conventional connection.

### With a cable box

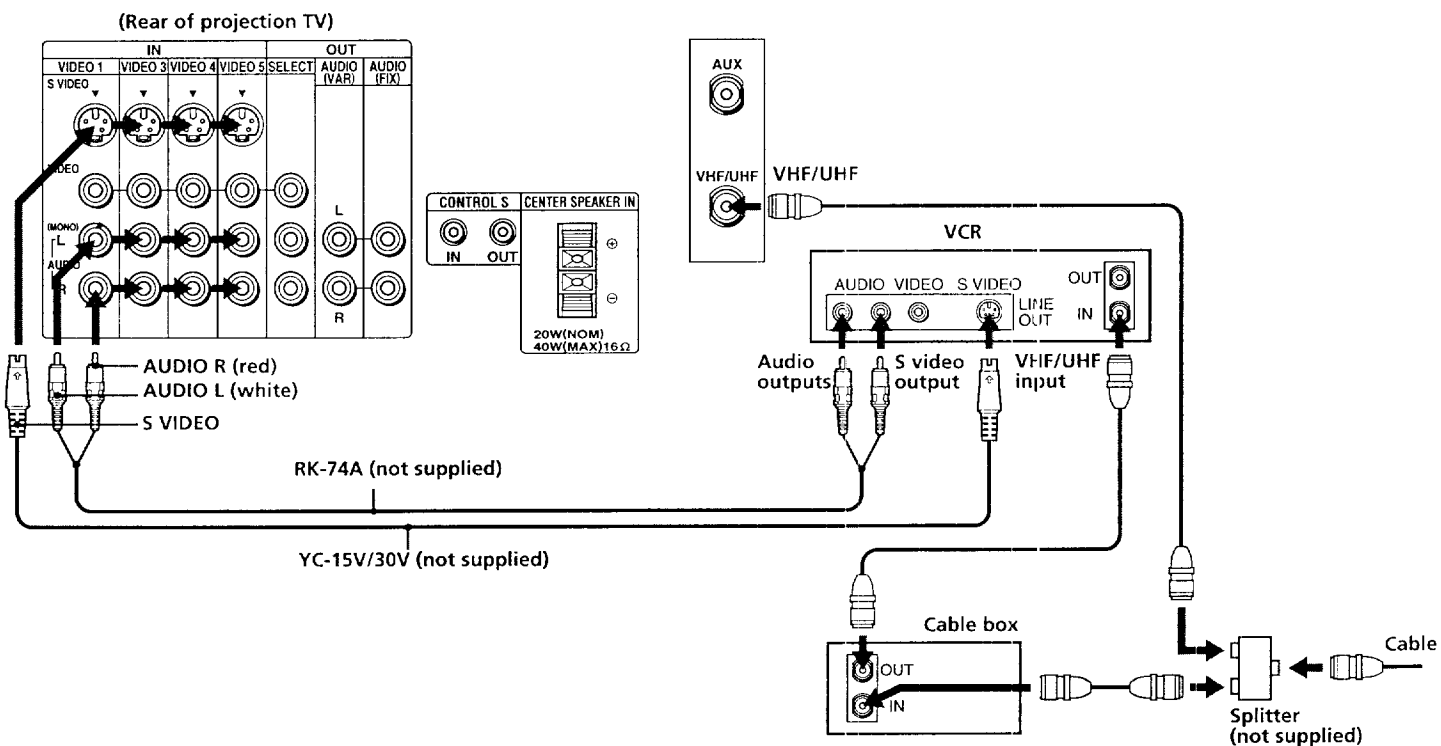



## Connecting a DBS receiver

For connection details, see the instruction manual of the DBS (Digital Broadcasting Satellites) receiver.

### To a projection TV

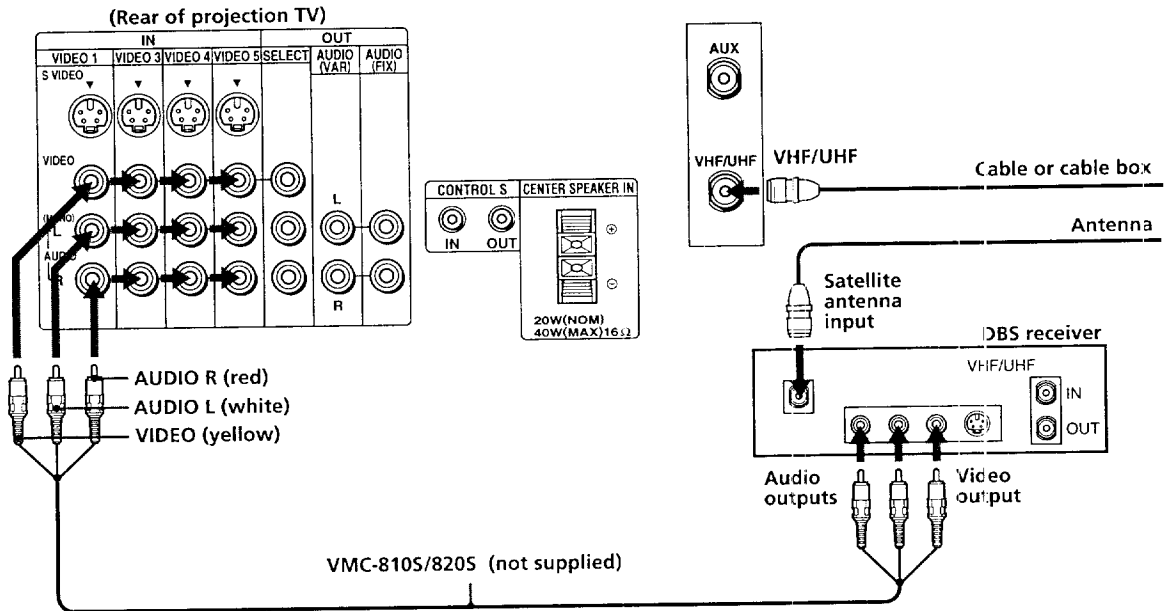

#### Note

- You can use the S VIDEO jack or the composite video jack for video connection.

### To a projection TV and VCR

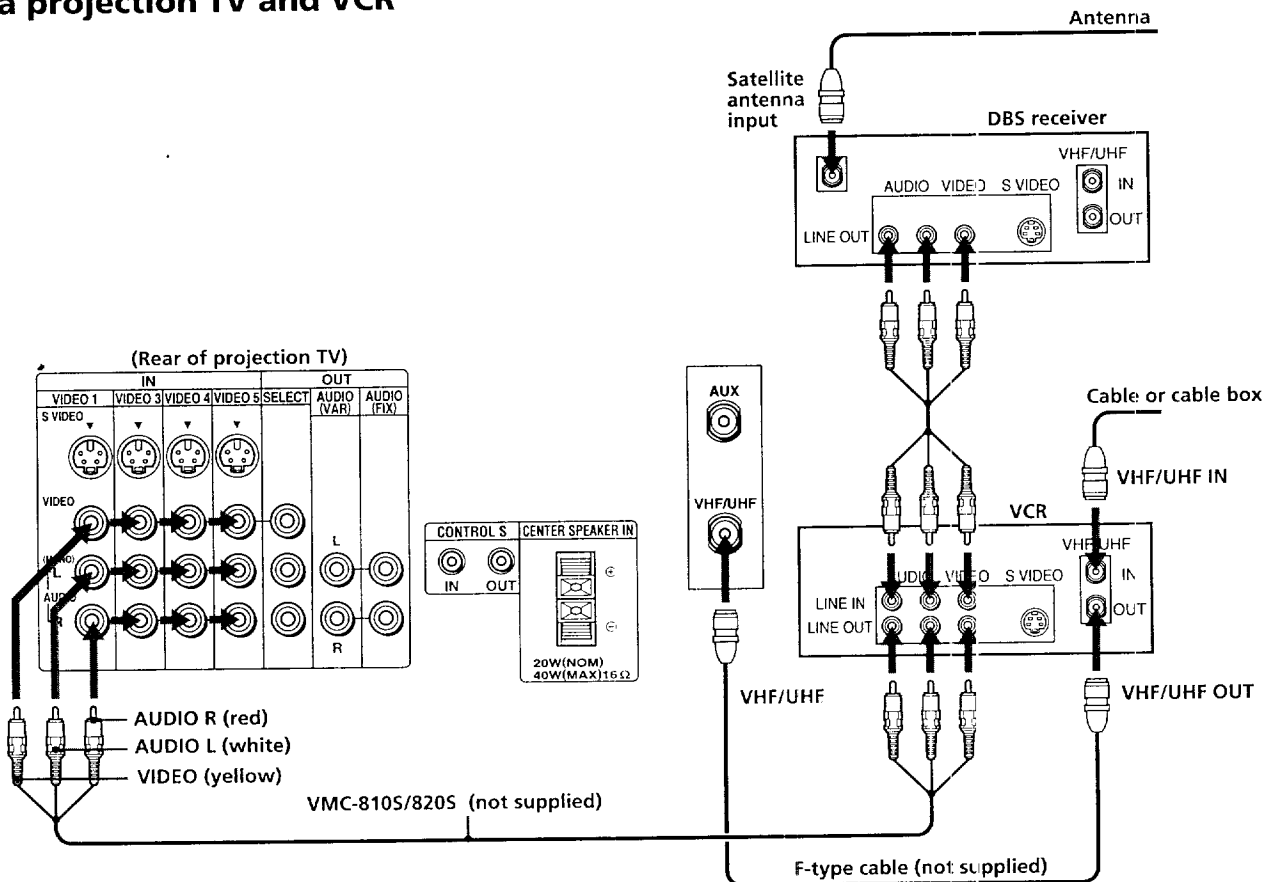

## Connecting a camcorder

This connection is convenient for watching a picture from a camcorder.

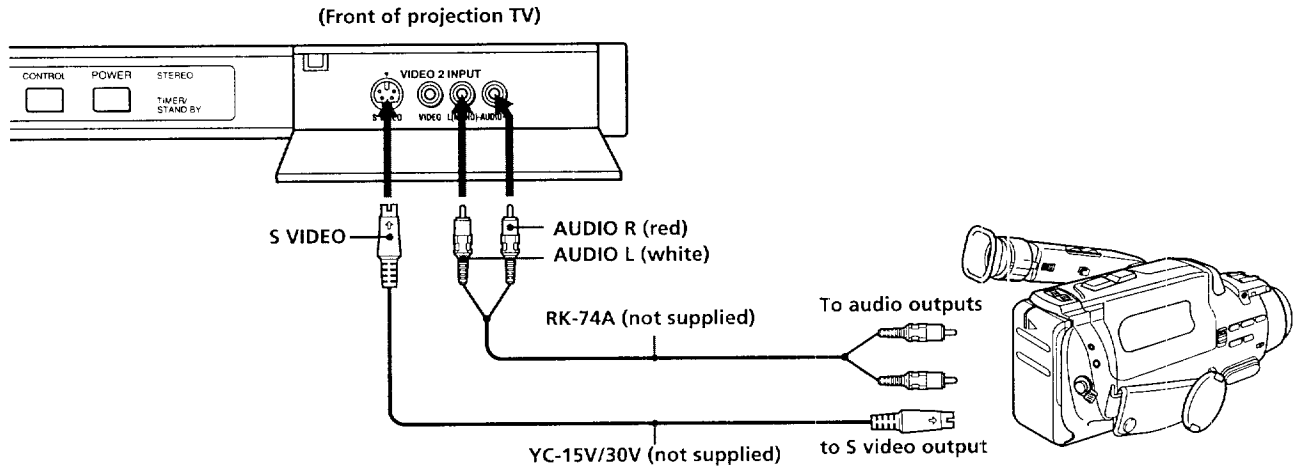

### Notes

- To connect a monaural camcorder, connect the audio output of the camcorder to AUDIO L (MONO) of VIDEO 2 INPUT of the projection TV.
- To connect a camcorder not equipped with the S video output, connect the video output of the camcorder to VIDEO INPUT of the projection TV.

## Connecting two VCRs for tape editing

You can select the output signal from the SELECT OUT jacks. For detailed information, see page 29.

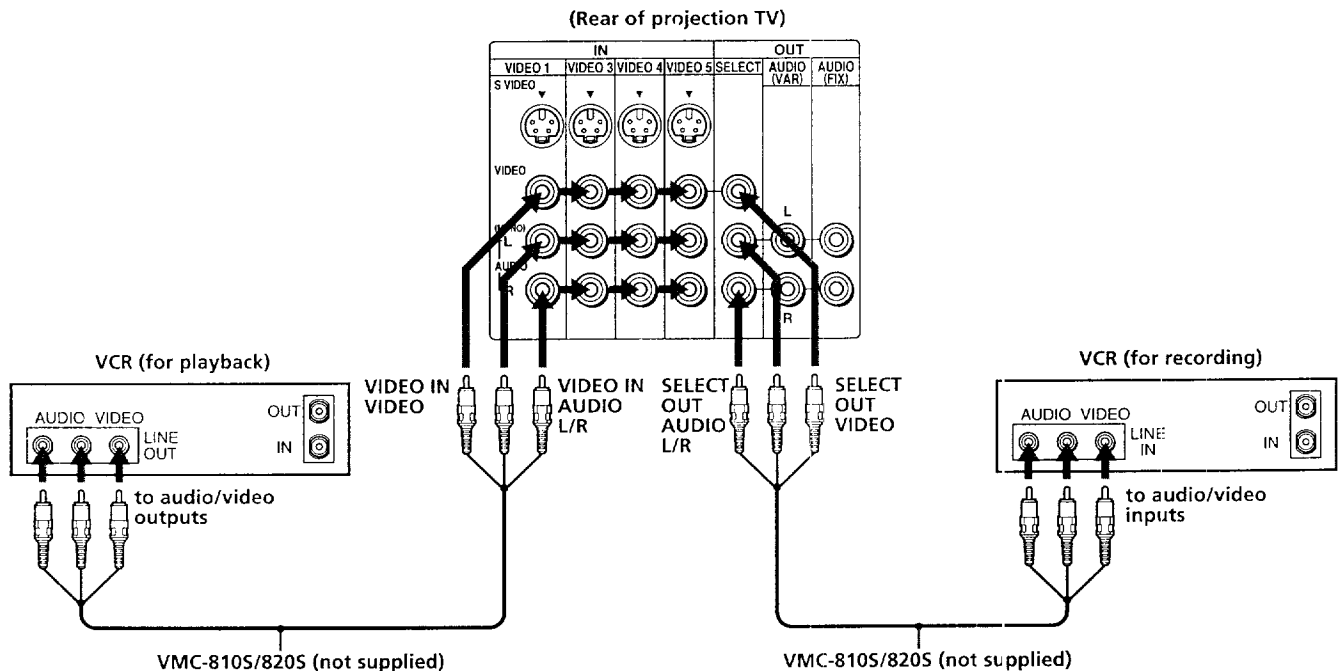

## Connecting an audio system

If you want to use the left and right speakers of a stereo amplifier, use AUDIO (VAR) OUT as shown below and switch off the projection TV speakers. (See "Setting the speaker switch (SPEAKER)" on page 27.)

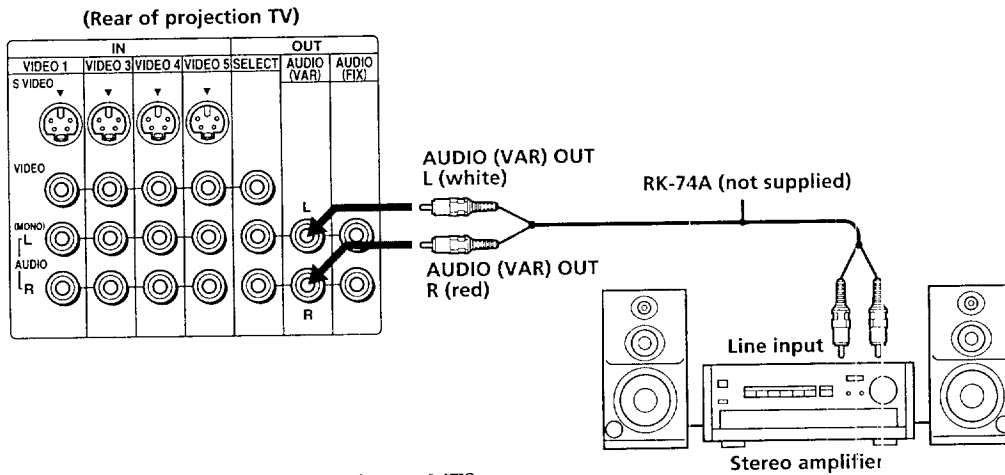

### Note

- You can adjust the bass, treble and balance, or select an MTS (Multichannel TV Sound) mode with the supplied remote commander.

## Connecting an amplifier with Dolby Pro Logic decoder

If you use an amplifier with Dolby Pro Logic decoder instead of the projection TV's audio system, you can use the projection TV's speaker as the center speaker. See "Setting the speaker switch (SPEAKER)" on page 27.

\* Manufactured under license from Dolby Laboratories Licensing Corporation. Additionally licensed under Canadian patent number 1,037,877. "Dolby," the double-D symbol  and "Pro Logic" are trademarks of Dolby Laboratories Licensing Corporation.

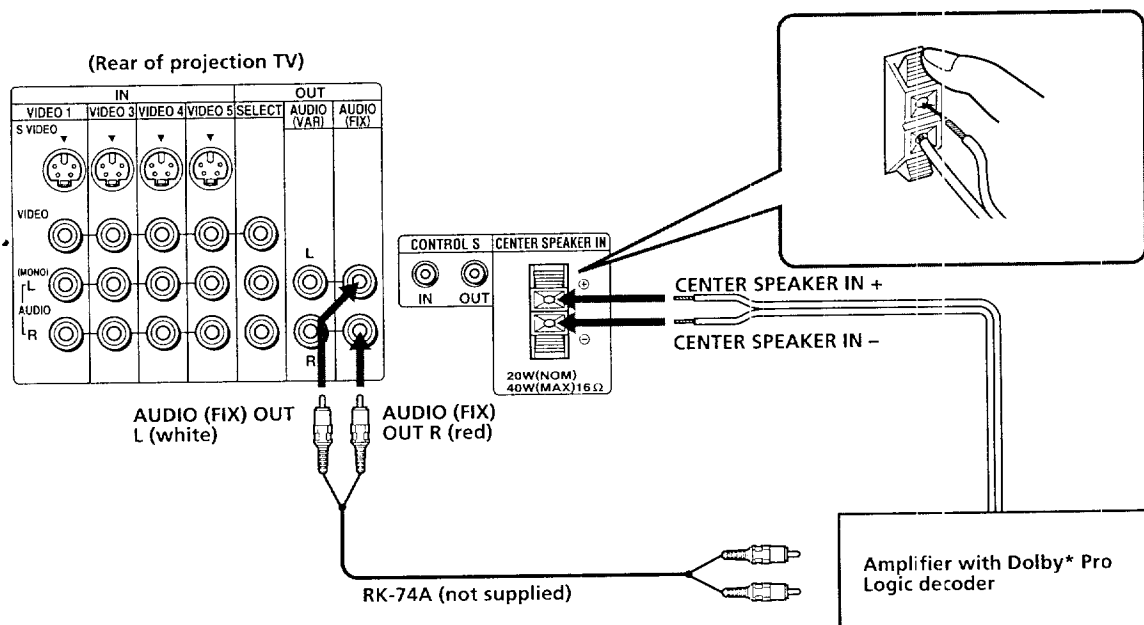

## Connecting an AV receiver

Connect an optional AV receiver to the VIDEO 1 IN jacks. For detailed information, see "Using the INPUT/OUTPUT menu" on page 29.

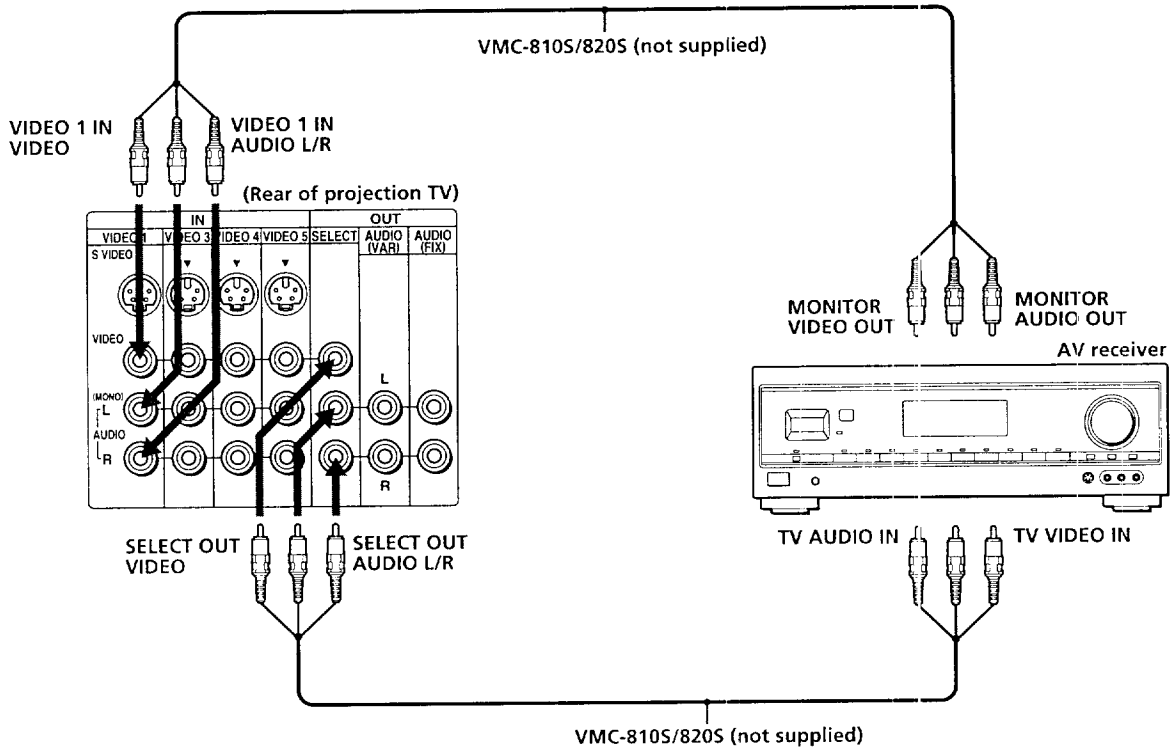

## Connecting other Sony equipment with the CONTROL S jacks

This feature allows you to control your projection TV and other Sony equipment with one remote commander.

### Notes

- To control other Sony equipment with the projection TV's remote commander, connect the CONTROL S input of the equipment to the CONTROL S OUT jack on the projection TV.
- To control the projection TV with the remote commander of other Sony equipment, connect the CONTROL S output of the equipment to the CONTROL S IN jack on the projection TV.

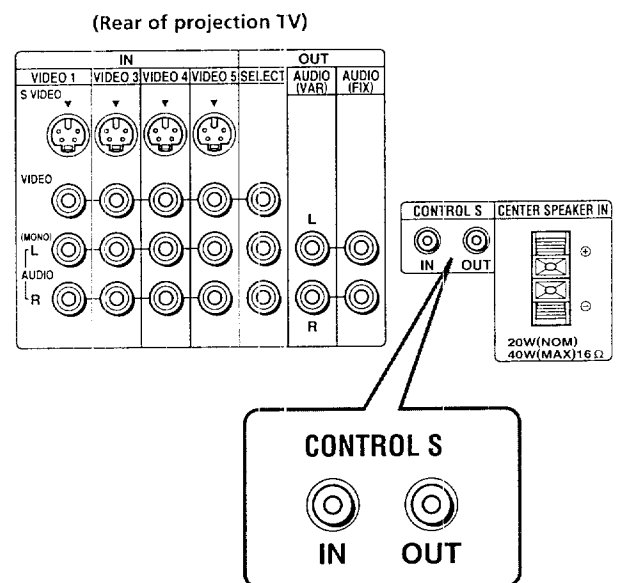

# Step 3: Setting up the remote commander

## Inserting batteries

Insert two size AA (R6) batteries (supplied) by matching the + and - on the batteries to the diagram inside the battery compartment.

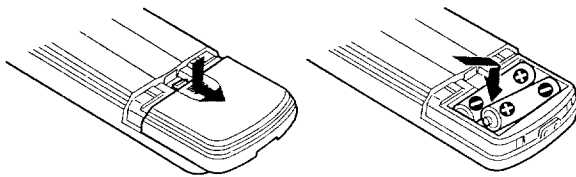

### Notes

- With normal use, the batteries should last for approximately six months.
- If you do not use the remote commander for an extended period of time, remove the batteries to avoid possible damage from battery leakage.
- Do not handle the remote commander roughly. Do not drop it, step on it or let it get wet.
- Do not place the remote commander in direct sunlight, near a heater, or where the humidity is high.

## Using the joystick remote commander for menu operation

The supplied remote commander has a joystick with motion in eight directions, as illustrated, to easily select the items in the menu.

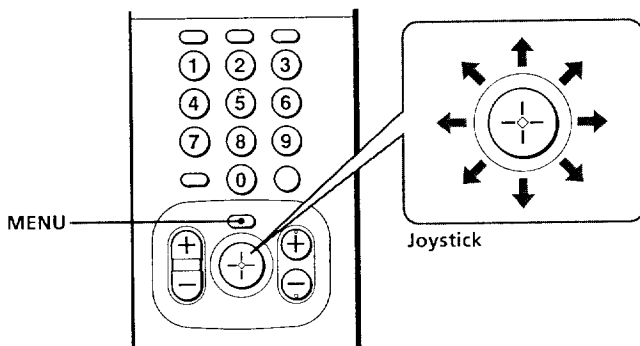

## How to use the menus

- 1 Press the MENU button to display the main menu.

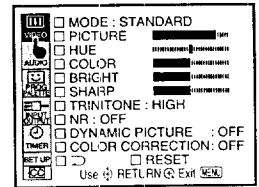

- 2 Press the joystick up or down to move the cursor (b) to the desired item.

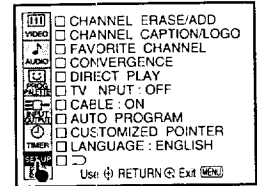
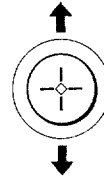

- 3 Click the joystick to display the selected menu.

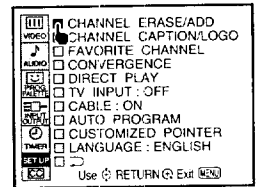
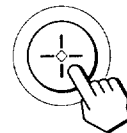

- 4 Press the joystick up or down to select the item, then click the joystick to go to the next menu.

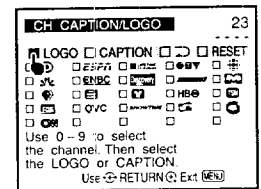
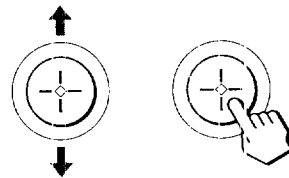

For further operations, you can select the item by pressing the joystick in some of eight directions that vary according to the selected menu. Then click the joystick to store the setting.

### To erase the main menu

Press MENU. The original screen is displayed.

### To return to the previous menu

Press the joystick up, down, right or left to move the cursor (b) to  $\rightarrow$  of each menu, and click the joystick.

### Note

- You can select one of various kinds of cursors (page 37).

# Step 4: Setting up the projection TV automatically (AUTO SET UP)

For customers who connect a cable box, skip this step and proceed to "Selecting the cable box output channel (TV INPUT)" (page 18).

You can set up your projection TV easily by using AUTO SET UP feature. It changes the on-screen menu language and presets all the receivable channels automatically. To set up the projection TV manually, see "Changing the menu language" (page 17) "Setting cable TV on or off" (page 16) and "Presetting channels" (page 17).

If the projection TV is set to a video input, you cannot execute AUTO SET UP. Press TV/VIDEO so that a channel number appears.

(Front of projection TV)

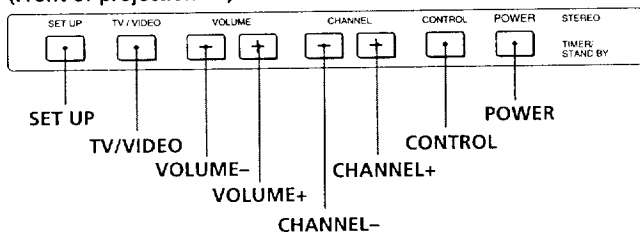

## 1 Press POWER to turn the projection TV on.



## 2 Press CONTROL.

The keys on the projection TV light up.

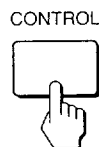

## 3 Press SET UP on the front of the projection TV.

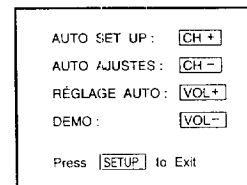

## 4 Press CHANNEL+.

If you prefer Spanish or French to English, you can change the on-screen menu language. Press CHANNEL- for Spanish or VOLUME+ for French.

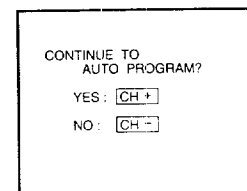
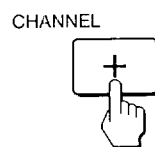

All of the menus will be set to the factory preset condition in the selected language.

## 5 Press CHANNEL+.

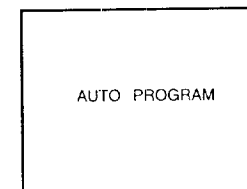
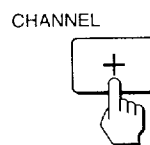

"AUTO PROGRAM" appears on the screen and the projection TV starts scanning and presetting channels automatically. When all the receivable channels are stored, "AUTO PROGRAM" disappears and the lowest numbered channel is displayed. If the projection TV receives cable TV channels, CABLE is set to ON automatically.

### Notes

- If more than 90 seconds elapse after you press a button, the menu disappears automatically.
- In case of using the AUX connector, press the ANT/AUX button on the remote commander first so that "AUX" is displayed beside the channel number on the screen. Then follow steps 2 to 4 above to perform AUTO SET UP.

### To preview the main functions (DEMO)

Press VOLUME- in step 2. The functions and menus are displayed one by one. To cancel the DEMO function, press VOLUME- again.

## Erasing or adding channels

After AUTO SET UP you can erase unnecessary channels or add the channels you want. Preset channels during the day rather than late at night, when some channels may not be broadcasting.

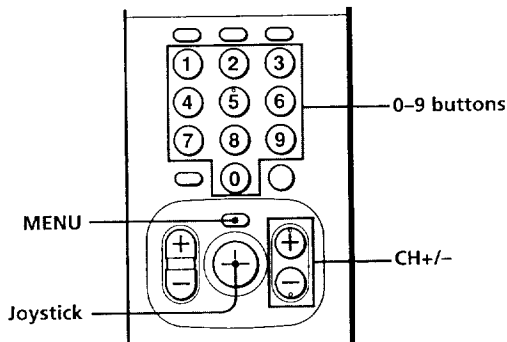

### 1 Press MENU.

The main menu appears.

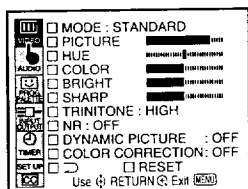

### 2 Press the joystick up or down to move the cursor (↕) to SET UP and click the joystick.

The SET UP menu appears.

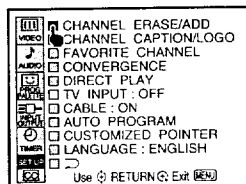
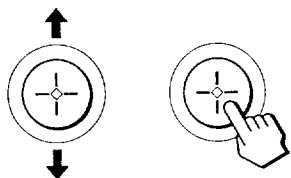

### 3 Make sure the cursor (↕) is beside CHANNEL ERASE/ADD and click the joystick.

If the cursor is not beside CHANNEL ERASE/ADD, press the joystick up or down to move the cursor and click the joystick.

The CH ERASE/ADD menu appears.

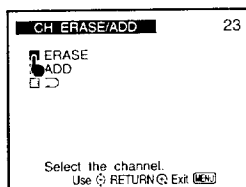
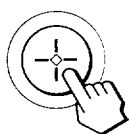

### 4 Erase or add the channel you want:

- (1) Press the joystick up or down to select ERASE or ADD.
- (2) Press CH +/- or 0-9 buttons to select the channel you want to erase or add.

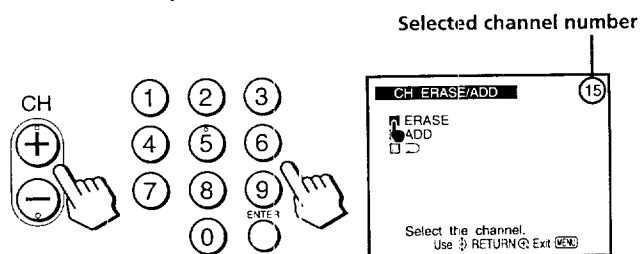

- (3) Click the joystick.

- If you select ERASE in step (1), "-" appears beside the channel number, showing that the channel is erased from the preset memory.
- If you select ADD in step (1), "+" appears beside the channel number, showing that the channel is added to the preset memory.

### 5 To erase and/or add other channels, repeat step 4.

### 6 When you finish, press MENU.



#### Notes

- If you erase or add a VHF or UHF channel, the cable TV channel with the same number is also erased or added.
- If more than 90 seconds elapse after you press a button, the menu disappears automatically.
- Erasing and adding channels is also available for the AUX input.

## Adjusting convergence (CONVERGENCE)

The projection tube image appears on the screen in three layers (red, green and blue). If they do not converge, the color is poor and the picture blurs. To correct this, adjust convergence.

- 1 Press **MENU**.
- 2 Press the joystick up or down to move the cursor (⬇) to **SET UP** and click the joystick.
- 3 Press the joystick up or down to move the cursor (⬇) to **CONVERGENCE** and click the joystick.

The CONVERGENCE adjustment screen appears.

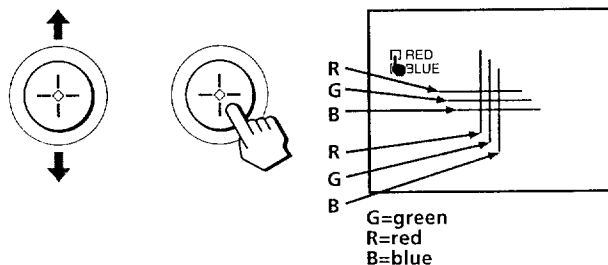

- 4 Press the joystick up or down to move the cursor (⬇) to **RED** or **BLUE**, and click the joystick.

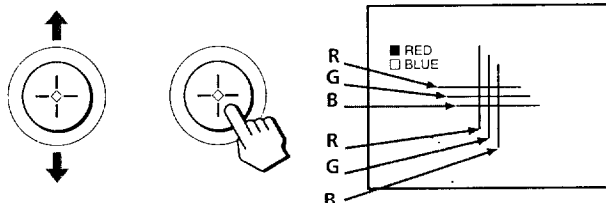

- 5 Press the joystick up, down, left or right to move the line until it converges with the center green line, and click the joystick.

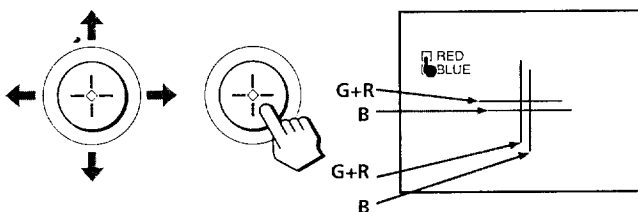

- 6 Repeat steps 4 and 5 to adjust the other lines until all three lines converge and are seen as a white cross.
- 7 Press **MENU** to return to the original screen.

### Note

- Convergence can be adjusted only left, right, up and down.

## Setting cable TV on or off

If you have connected the projection TV to a cable TV system, set **CABLE** to **ON**, the factory setting. If not, set **CABLE** to **OFF**. You do not have to do this procedure if you execute **AUTO SET UP** (page 14). Do this procedure only when you want to set it manually.

- 1 Press **MENU**.
- 2 Press the joystick up or down to move the cursor (⬇) to **SET UP** and click the joystick.
- 3 Press the joystick up or down to move the cursor (⬇) to **CABLE** and click the joystick.

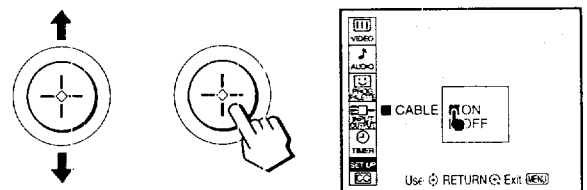

- 4 Press the joystick up or down to select **ON** or **OFF** and click the joystick.

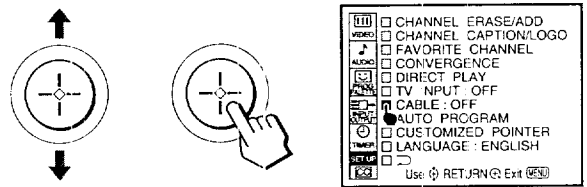

- 5 Press **MENU** to return to the original screen.

### Note

- If **CABLE** appears in grey, the projection TV is set to a video input and you cannot select **CABLE**. Press **TV/VIDEO** on the remote commander so that a channel number appears.



## Presetting channels

You can preset TV channels easily by AUTO PROGRAM feature. You do not have to do this procedure if you execute AUTO SET UP (page 14). Do this procedure only when you want to set it manually.

- 1 Press **MENU**.
- 2 Press the joystick up or down to move the cursor (b) to **SET UP** and click the joystick.

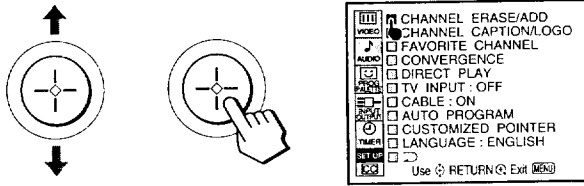

- 3 Press the joystick up or down to move the cursor (b) to **AUTO PROGRAM** and click the joystick.

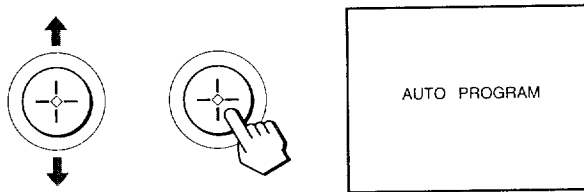

"AUTO PROGRAM" appears on the screen and the projection TV starts scanning and presetting channels automatically. When all the receivable channels are stored, "AUTO PROGRAM" disappears and the lowest numbered channel is displayed.

- 4 Press **MENU** to return to the original screen.

### Notes

- If AUTO PROGRAM appears in grey in the SET UP menu, the projection TV is set to a video input and you cannot select AUTO PROGRAM. Press TV/VIDEO on the remote commander so that a channel number appears.
- If more than 90 seconds elapse after you press a button, the menu disappears automatically.
- Presetting channels is also available for the AUX input.

## Changing the menu language

If you prefer Spanish or French to English, you can change the menu language. You do not have to do this procedure if you execute AUTO SET UP (page 14). Do this procedure only when you want to set it manually.

- 1 Press **MENU**.
- 2 Press the joystick up or down to move the cursor (b) to **SET UP** and click the joystick.
- 3 Press the joystick up or down to move the cursor (b) to **LANGUAGE** and click the joystick.

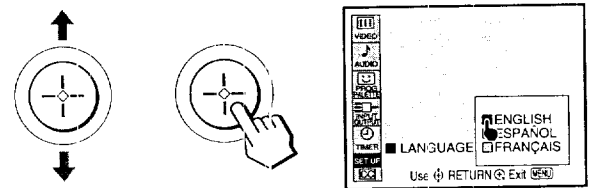

- 4 Press the joystick up or down to select the language and click the joystick.  
The menu in the selected language appears.

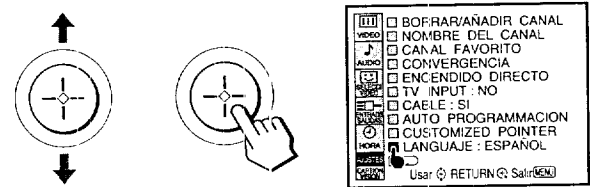

- 5 Press **MENU** to return to the original screen.

### Note

- Even when you select Spanish or French language, certain parts of the menus remain in English.

# Selecting the cable box output channel (TV INPUT)

If you use a cable box, you can select the cable box output channel on your projection TV. It is recommended that you set up your projection TV as follows when you use a cable box.

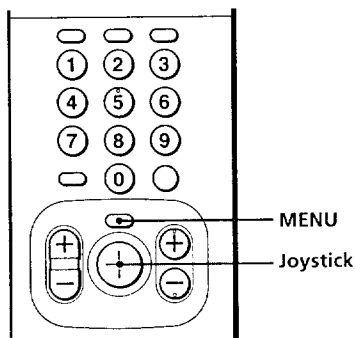

- 1 Press MENU.**
- 2 Press the joystick up or down to select SET UP and click the joystick.**
- 3 Press the joystick up or down to select TV INPUT and click the joystick.**

The cable box output channel options are displayed.

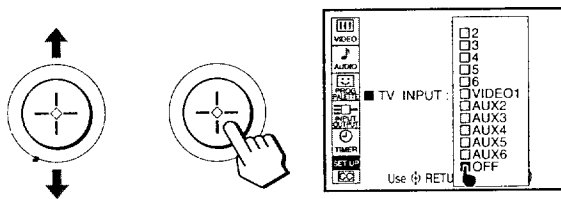

- 4 Press the joystick up or down to select the cable box output channel and click the joystick.**

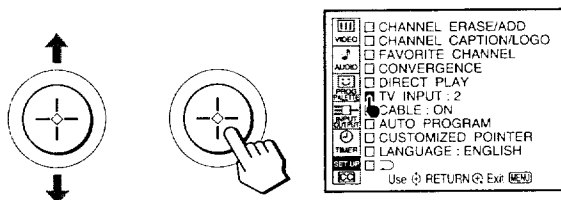

You can select the cable output channel among 2–6 channels, VIDEO 1 and AUX 2–6 channels.

## Notes

- If you set TV INPUT to any option other than OFF, you cannot use the favorite channel and CH INDEX features.
- If you set TV INPUT to VIDEO 1 INPUT mode, you cannot select TV INPUT again. Press the TV/VIDEO button to select and return to TV INPUT mode. If you are unable to return to the TV INPUT mode by using the TV/VIDEO button, select TV OUT in "Using the INPUT/OUTPUT menu" on page 29, and enter NC.
- If TV INPUT is set to OFF and you cannot receive any channels, press the ANT/AUX button on your remote commander.

# Watching the TV

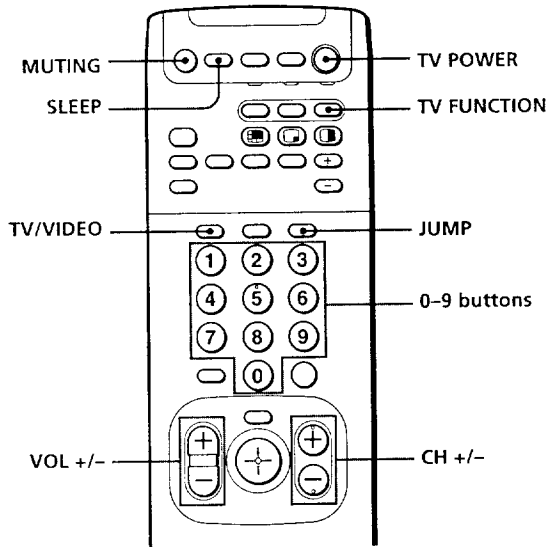

## 1 Press TV FUNCTION on the remote commander.

The red indicator flashes once on the remote commander, indicating that the buttons function for the projection TV.



## 2 Press TV POWER to turn on the projection TV.

The POWER indicator lights on the projection TV.

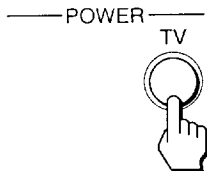

If any of "VIDEO1 to VIDEO5" appears on the screen, press the TV/VIDEO button until a channel number appears.

## 3 Select the channel you want to watch:

### To select a channel directly

Press the 0 - 9 buttons

For example, to select channel 10, press 1 and 0.

You may press ENTER to immediately change the channel.

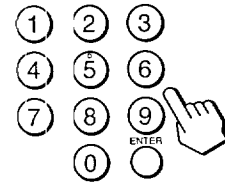

### To scan through channels

Press CH +/- until the channel you want to watch appears.

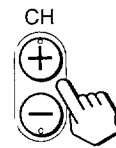

## 4 Press VOL +/- to adjust the volume.

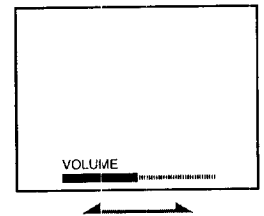

## Switching quickly between two channels

You can use the JUMP button to switch or "jump" back and forth between two channels.

### Press JUMP.



Pressing JUMP again switches back to the original channel.

### Note

- You cannot jump to channels you scanned through using the CH +/- buttons.

---

## Muting the sound

Press **MUTING**.

"MUTING" appears on the screen.



To restore the sound, press MUTING again, or press VOL +.

---

## Displaying on-screen information

Press **DISPLAY** repeatedly until the desired display appears.

Each time you press DISPLAY, the display changes as follows:

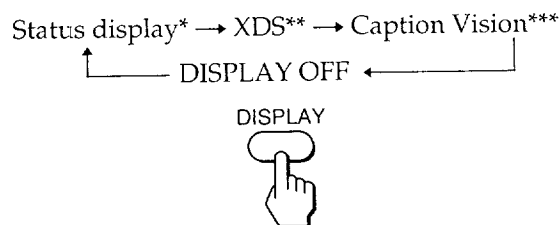

- \* Channel number, the current time, channel caption (if set), and MTS mode (if SAP is selected) are displayed. SAP indication disappears after three seconds.
- \*\* Some programs are broadcast with XDS (Extended Data Service) which shows a network name, program name, program type, program length, call letters, and time of the show. When you select XDS with the DISPLAY button, this information will be displayed on the screen if the broadcaster offers this service.
- \*\*\* Some programs are broadcast with Caption Vision. When you select Caption Vision with the DISPLAY button, Caption Vision will be displayed on the screen if the broadcaster offers this service. (See page 38 for selecting Caption Vision.)

To cancel the display, press DISPLAY repeatedly until "DISPLAY OFF" appears. "DISPLAY OFF" goes off after three seconds.

---

## Freezing the picture

You can freeze the picture.

Press **FREEZE**.



This feature is useful when you want to write down a recipe from a cooking program, a displayed address or phone number or the like.

To restore the normal screen, press PIP OFF.

### Note

- This feature is also available for PIP/P&P mode. See page 23.

---

## Setting the Sleep Timer

The projection TV stays on for the length of time you specify and then shuts off automatically.

Press **SLEEP** repeatedly until the time (in minutes) you want appears.

Each time you press SLEEP, the time changes as follows: 30 → 60 → 90 → OFF.



"SLEEP" appears about one minute before the projection TV shuts off.

To cancel the Sleep Timer, press SLEEP repeatedly until "SLEEP OFF" appears, or turn off the projection TV.

The sleep timer is also canceled when you select AUTO PROGRAM under the SET UP menu.

## Watching a video input picture

Press TV/VIDEO repeatedly until the desired video input appears.

Each time you press TV/VIDEO, the display changes as follows: TV → VIDEO 1 → VIDEO 2 → VIDEO 3 → VIDEO 4 → VIDEO 5.



To return to TV picture, press TV/VIDEO until a channel number appears.

## Changing the VHF/UHF input to the AUX input

Press ANT/AUX.

"AUX" appears beside the channel number.



Pressing ANT/AUX again switches back to the VHF/UHF input.  
When switching from "VIDEO" to "AUX," TV must be pressed twice.

## Watching two programs at one time — PIP/P&P (Twin View™)

You can watch two programs simultaneously using the Picture-in-Picture (PIP) or the Picture-and-Picture (Twin View™) feature.

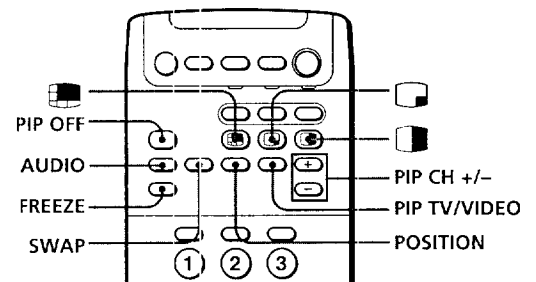

## Displaying a window picture (PIP)

Press .

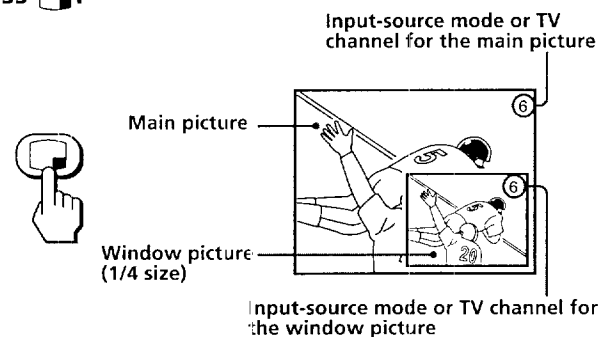

Press  repeatedly to display a smaller window picture.

Each time you press , the size of the window picture changes as follows: 1/4 size → 1/9 size → 1/16 size.

To remove the window picture, press PIP OFF.

## Displaying a left picture (P&P)

Press .

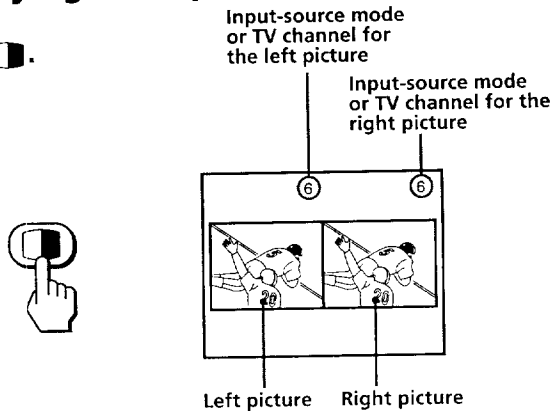

The main picture is on the right and the window picture is on the left.  
To restore the normal picture, press PIP OFF.

### Notes

- If the main/right picture is not receiving an image, the window/left picture may become a noisy picture.
- The window/left picture sound is also output from the AUDIO (VAR) OUT jacks when you listen to it.

## Changing the window/left picture input mode

Press PIP TV/VIDEO to select the input mode.

Each time you press PIP TV/VIDEO, "TV," "VIDEO 1," "VIDEO 2," "VIDEO 3," "VIDEO 4" and "VIDEO 5" appear in sequence.

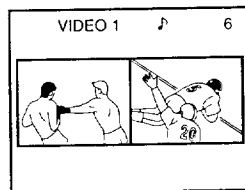

## Changing TV channels in the window/left picture

Press PIP CH +/-.

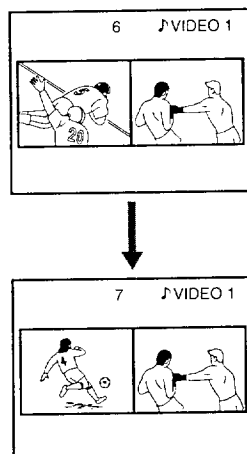
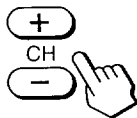

## Listening to the sound of the window/left picture

Press AUDIO.

"♪" appears for a few seconds on the window/left picture, indicating that the window/left picture sound is being received.

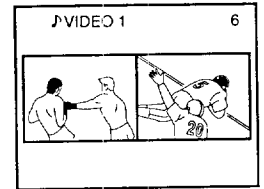

To restore the main/right picture sound, press AUDIO again.

## Changing the position of the window picture

Press POSITION.

Each time you press POSITION, the window picture will move as illustrated.

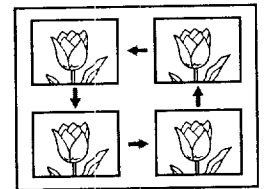

### Note

- POSITION is not a P&P feature.

## Swapping the main/right and window/left pictures

Press SWAP.

Each time you press SWAP, the images and sound from the main/right and window/left pictures switch places.

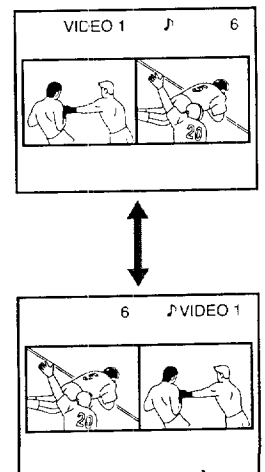
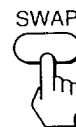

## Freezing the pictures

You can freeze both the right and left pictures.

This feature is useful when you want to write down a recipe from a cooking program, a displayed address, a phone number, etc.

Press **FREEZE**.

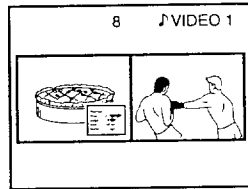

To restore the normal screen, press PIP OFF.

## Watching eight TV channels at one time (CH INDEX)

You can display all the preset channels in sequence.

Press .

A main picture and seven window pictures are displayed.

Each time you press  or PIP CH+/-, the next seven sequential channels appear.

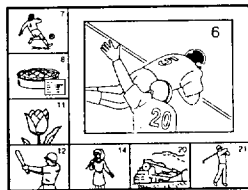

To return to the normal picture, press PIP OFF.

### Note

- If you set TV INPUT to any option other than OFF, you cannot use the CH INDEX feature.

# Using the VIDEO menu

## Adjusting the picture (VIDEO)

When watching TV programs, you can adjust picture, hue, color, brightness and sharpness to suit your taste. The adjusted level is stored in PROGRAM PALETTE.

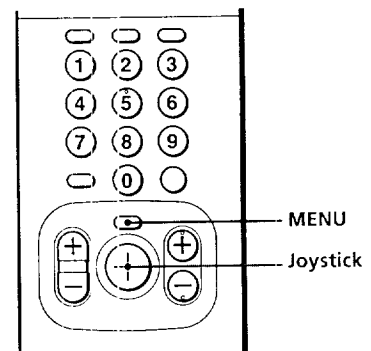

**1 Press MENU.**

**2 Make sure the cursor is beside VIDEO and click the joystick.**

If the cursor is not beside VIDEO, press the joystick up or down to move the cursor.

The VIDEO adjustment menu appears.

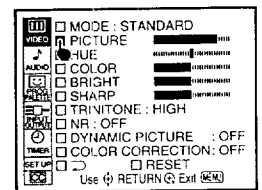
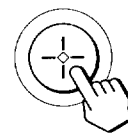

**3 Select the item you want to adjust.**  
For example:

- (1) To adjust brightness, press the joystick up or down to select BRIGHT.

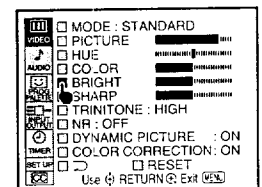
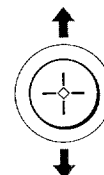

(continued)

(2) Click the joystick.

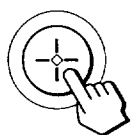

#### 4 Adjust the selected item:

(1) Press the joystick up, down, right or left to adjust the item.

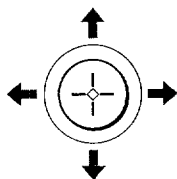

(2) Click the joystick.

The new setting appears in the VIDEO menu, and is stored in the displayed PROGRAM PALETTE mode.

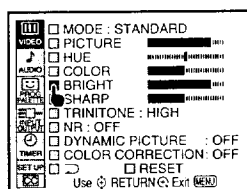
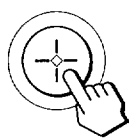

For details on each item, see "Description of adjustable items" below.

#### 5 To adjust other items, repeat steps 3 and 4.

##### Description of adjustable items

| Item    | Press the joystick up or right to          | Press the joystick down or left to        |
|---------|--|---|
| PICTURE | Increase picture contrast for vivid color. | Decrease picture contrast for soft color. |
| HUE     | Make overall picture greenish.             | Make overall picture purplish.            |
| COLOR   | Increase color intensity.                  | Decrease color intensity.                 |
| BRIGHT  | Brighten the picture.                      | Darken the picture.                       |
| SHARP   | Sharpen the picture.                       | Soften the picture.                       |

##### To restore the factory setting

While the VIDEO menu is displayed, press the joystick up, down, right or left to select RESET and click the joystick.

The Trinitone, NR, dynamic picture and color correction are also reset to the factory settings.

## Adjusting the color temperature (TRINITONE)

The TRINITONE feature controls the color temperature, permitting white balance preference adjustment without affecting skin tones.

**1 Press MENU.**

**2 Press the joystick up or down to select VIDEO and click the joystick.**

**3 Press the joystick up or down to select TRINITONE and click the joystick.**

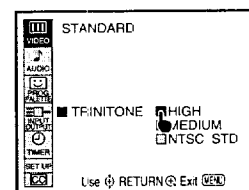
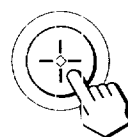
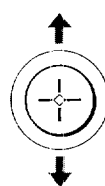

**4 Press the joystick up or down to select HIGH, MEDIUM or NTSC STD and click the joystick.**

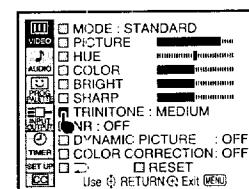
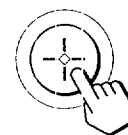

| Choose   | For                    |
|----------|------------------------|
| HIGH     | a cool (bluish) white  |
| MEDIUM   | a neutral white        |
| NTSC STD | a warm (reddish) white |

## Reducing picture noise (NR)

You can improve a weak or snowy picture when NR is set to ON.

**1 Press MENU.**

**2 Press the joystick up or down to select VIDEO and click the joystick.**



- 3 Press the joystick up or down to select NR and click the joystick.**

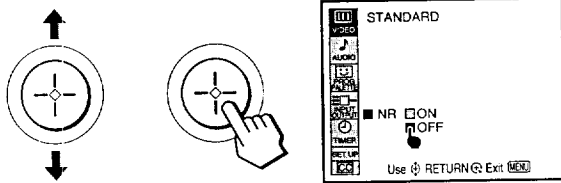

- 4 Press the joystick up or down to select ON and click the joystick.**

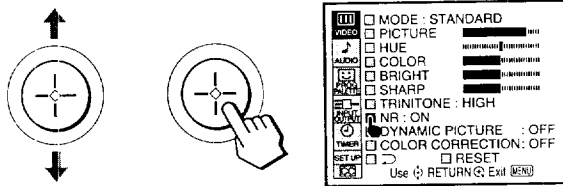

## Correcting the color (COLOR CORRECTION)

The COLOR CORRECTION feature emphasizes red and blue to make skin tones vivid.

- 1 Press MENU.**
- 2 Press the joystick up or down to select VIDEO and click the joystick.**
- 3 Press the joystick up or down to select COLOR CORRECTION and click the joystick.**

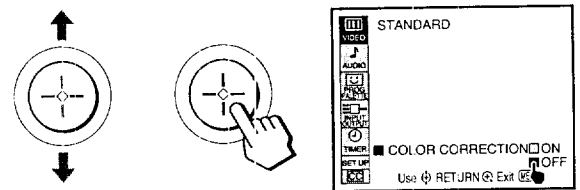

- 4 Press the joystick up or down to select ON and click the joystick.**

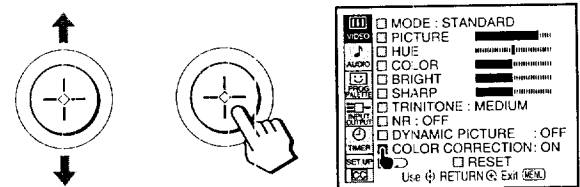

## Enhancing the picture contrast (DYNAMIC PICTURE)

The DYNAMIC PICTURE feature enhances the contrast of the picture, providing a dynamic image.

- 1 Press MENU.**
- 2 Press the joystick up or down to select VIDEO and click the joystick.**
- 3 Press the joystick up or down to select DYNAMIC PICTURE and click the joystick.**

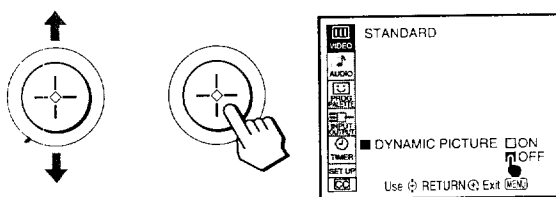

- 4 Press the joystick up or down to select ON and click the joystick.**

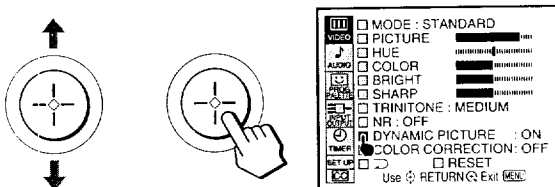

# Using the AUDIO menu

## Adjusting the sound (AUDIO)

You can adjust the treble, bass and balance to suit your taste. You can adjust the sound of video input(s) as well.

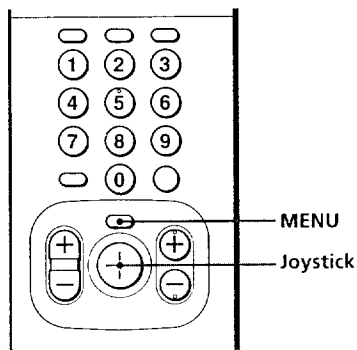

**1 Press MENU.**

**2 Press the joystick up or down to select AUDIO and click the joystick.**

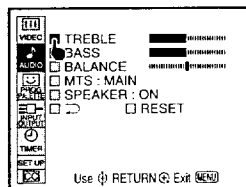
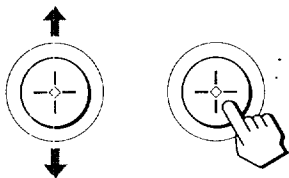

**3 Select the item you want to adjust.**  
**For example:**

(1) To adjust bass, press the joystick up or down, to select BASS.

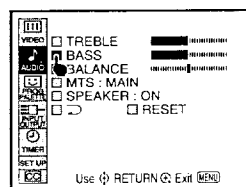
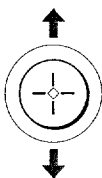

(2) Click the joystick.

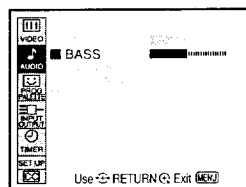
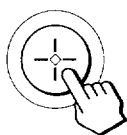

**4 Adjust the selected item:**

(1) Press the joystick up, down, right or left to adjust the item.

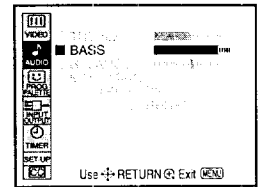
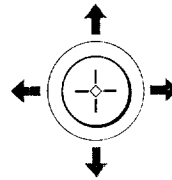

(2) Click the joystick.

The new setting appears in the AUDIO menu.

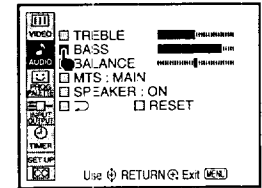
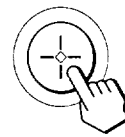

For details on each item, see "Description of adjustable items" below.

**5 To adjust other items, repeat steps 3 and 4 above.**

### Description of adjustable items

| Item    | Press the joystick up or right to     | Press the joystick down or left to   |
|---------|---------------------------------------|--------------------------------------|
| TREBLE  | Increase the treble response.         | Decrease the treble response.        |
| BASS    | Increase the bass response.           | Decrease the bass response.          |
| BALANCE | Emphasize the right speaker's volume. | Emphasize the left speaker's volume. |

### To restore the factory settings

While the AUDIO menu is displayed, press the joystick up, down, right or left to select RESET and then click the joystick. All the settings in the AUDIO menu are reset to the factory settings.

## Selecting stereo or bilingual programs (MTS)

The Multichannel TV Sound (MTS) feature gives you the choice to enjoy stereo sound or Second Audio Programs (SAP) when available. The initial setting is stereo sound (MAIN).

- 1 Press **MENU**.
- 2 Press the joystick up or down to select **AUDIO** and click the joystick.
- 3 Press the joystick up or down to select **MTS** and click the joystick.

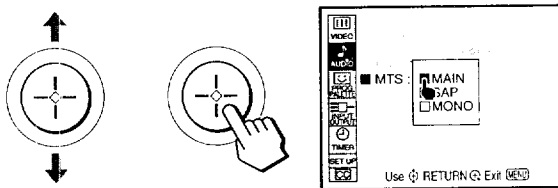

- 4 Press the joystick up or down to select **MAIN, SAP or MONO** and click the joystick.

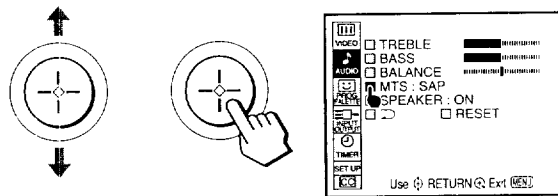

| Choose | To   |
|--------|--|
| MAIN   | Listen to stereo sound.<br>The STEREO indicator on the projection TV lights up while a stereo broadcast is received. |
| SAP    | Listen to bilingual programs.<br>The sound of non-SAP programs will be muted when SAP is selected.                   |
| MONO   | Reduce noise during stereo broadcasts.   |

### Note

- Stereo and SAP sounds are subject to program sources.

## Setting the speaker switch (SPEAKER)

You may switch off the projection TV speakers when, for example, you want to listen to the sound through a stereo system.

If you connect an amplifier with Dolby Pro Logic decoder to the CENTER SPEAKER IN terminal, you can use the projection TV speakers as center speaker.

- 1 Press **MENU**.
- 2 Press the joystick up or down to select **AUDIO** and click the joystick.
- 3 Press the joystick up or down to select **SPEAKER** and click the joystick.

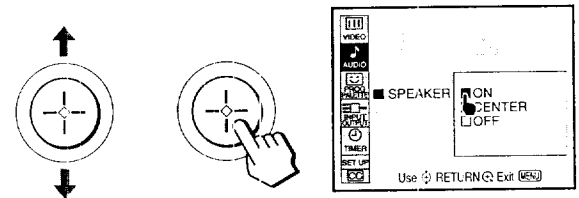

- 4 Press the joystick up or down to select **ON, CENTER or OFF** and click the joystick.

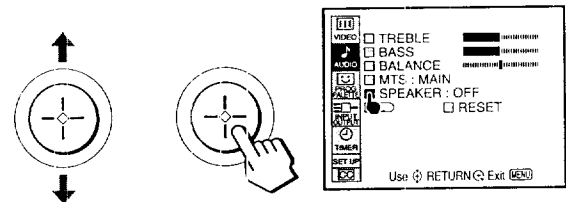

| Choose | To   |
|--------|--|
| ON     | Listen to the sound from the projection TV.  |
| CENTER | Use the projection TV center speakers as the center speaker in another surround audio system.                              |
| OFF    | Turn off the projection TV speaker sound and listen to the projection TV's sound solely through the audio system speakers. |

# Using the PROGRAM PALETTE menu

## Selecting picture effect (PROGRAM PALETTE)

You can select one of five modes for picture effect that best suits the different programs.  
You can also adjust the picture for each setting to suit your taste.

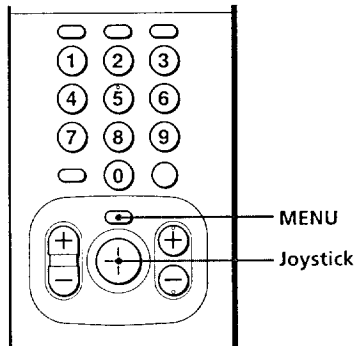

- 1 Press MENU.
- 2 Press the joystick up or down to select PROG PALETTE and click the joystick.

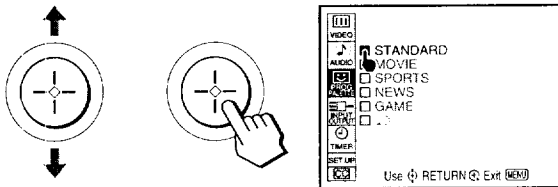

- 3 Select the item you want.  
For example:

(1) To select MOVIE, press the joystick up or down to move the cursor to MOVIE.

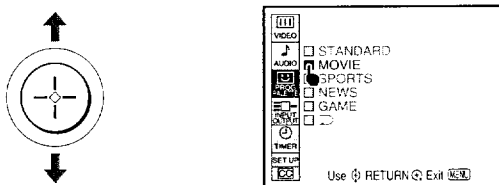

(2) Click the joystick.

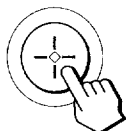

For details on each item, see "Effect of picture settings" below.

## Effect of picture settings

| Item     | Picture effect           |
|----------|--------------------------|
| STANDARD | Standard                 |
| MOVIE    | Finely detailed picture  |
| SPORTS   | Vivid, bright picture    |
| NEWS     | Reduced noise in picture |
| GAME     | Softer picture           |

## Adjusting the picture in PROGRAM PALETTE

- 1 Press MENU.
- 2 Press the joystick up or down to select VIDEO and click the joystick.

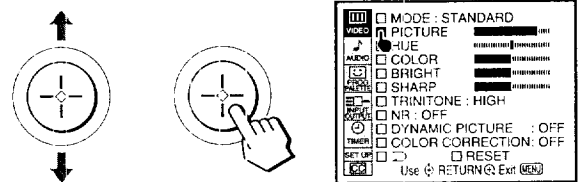

- 3 Press the joystick up or down to select MODE and click the joystick.

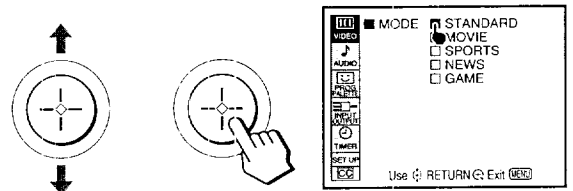

- 4 Press the joystick up or down to select the item you want to adjust and click the joystick.

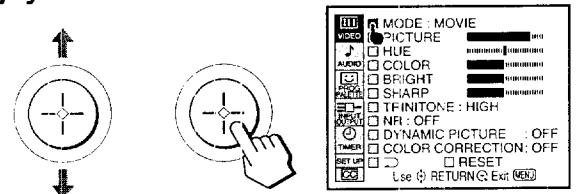

- 5 Adjust the picture according to the steps 3 to 5 in "Adjusting the picture" on page 23.

## To restore the factory setting

While the VIDEO menu is displayed, press the joystick up, down, right or left to select RESET and click the joystick.

# Using the INPUT/OUTPUT menu

## Selecting an output signal (INPUT/OUTPUT)

You can select an output signal from the SELECT OUT jacks at the rear of the projection TV.

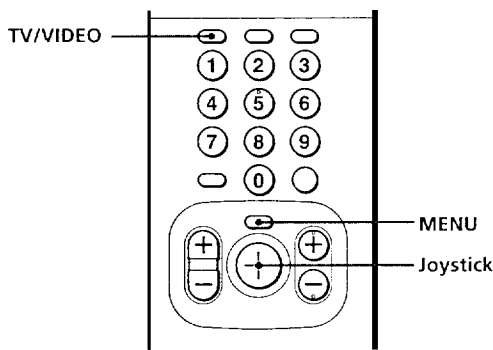

**1 Press MENU.**

**2 Press the joystick up or down to select INPUT/OUTPUT and click the joystick.**

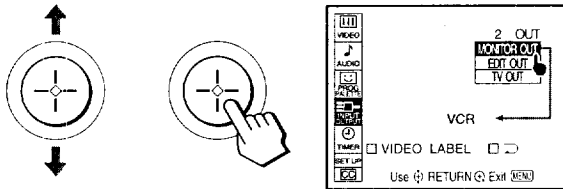

**3 Select MONITOR OUT, EDIT OUT or TV OUT.**

| Select      | To  |
|-------------|---|
| MONITOR OUT | Output the signal of the picture displayed on the projection TV screen. Use this option to edit tapes while monitoring.   |
| EDIT OUT    | Output the signal input to the projection TV regardless of the displayed picture on the screen. Use this option to edit tapes while watching an input image different from that being recorded. |
| TV OUT      | Output the TV signal. Use this option when you connect an AV receiver to the VIDEO 1 IN jacks.  |

### To select MONITOR OUT:

- (1) Make sure the cursor is beside MONITOR OUT and click the joystick.
- (2) Press TV/VIDEO to select the input to the projection TV and click the joystick.

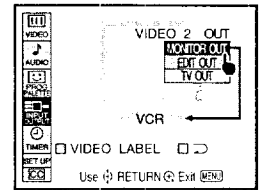

### To select EDIT OUT:

- (1) Press the joystick up or down to select EDIT OUT and click the joystick.
- (2) Press the joystick up or down to select the input to be edited and click the joystick.

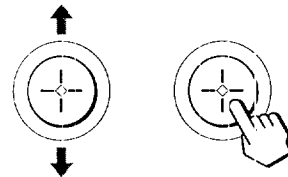

### To select TV OUT:

- (1) Press the joystick up or down to select TV OUT and click the joystick. "Set up using only VIDEO1 input?" appears.

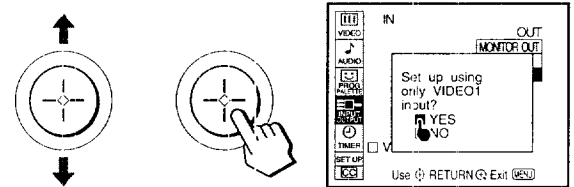

- (2) If you connect only an AV receiver to your projection TV, press the joystick up or down to select YES. Then click the joystick. You can always select the signal from the receiver by pressing TV/VIDEO once. If you connect your audio/video equipment to the projection TV, select NO. You can select any of the VIDEO 1 to VIDEO 5 inputs with the TV/VIDEO button.

### Notes

- When you set INPUT/OUTPUT to TV OUT, you cannot swap the main/right and window/left pictures.
- The SELECT OUT signal is only available when the projection TV is on.

## Setting video labels (VIDEO LABEL)

This feature allows you to label each input mode so that you can easily identify the connected equipment. For example, you can label VIDEO 2 IN as VHS.

- 1** Press **MENU**.
- 2** Press the joystick up or down to select **INPUT/OUTPUT** and click the joystick.
- 3** Press the joystick up, down, right or left to select **VIDEO LABEL** and click the joystick.

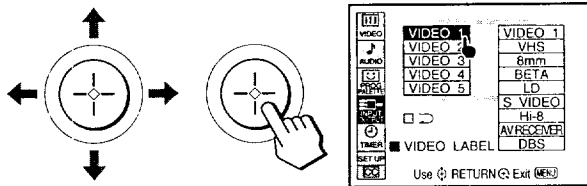

- 4** Press the joystick up or down to select the input mode you want to label and click the joystick.

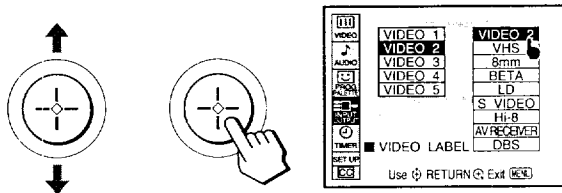

- 5** Press the joystick up or down to select the label and click the joystick.

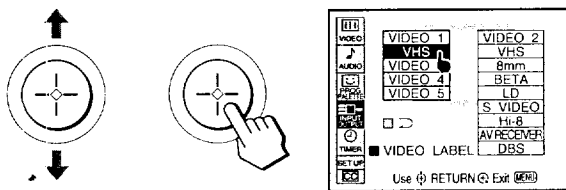

- 6** Repeat steps 4 and 5 to label other input modes.

### Note

- If more than 90 seconds elapse after you press a button, the menu disappears automatically.

## Using the TIMER menu

### Setting the clock (CURRENT TIME)

Setting the clock enables you to check the time, turn the projection TV on and off with the timer, or to block a TV channel from being watched at a certain time.

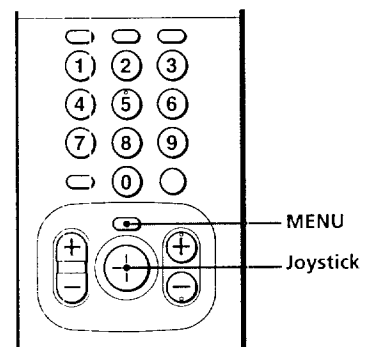

- 1** Press **MENU**.
- 2** Press the joystick up or down to select **TIMER** and click the joystick.

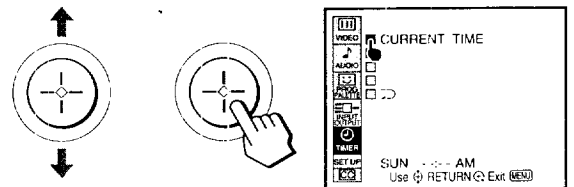

- 3** Make sure the cursor (b) is beside **CURRENT TIME**, and click the joystick.

If the cursor is not beside CURRENT TIME, press the joystick up or down to move the cursor.

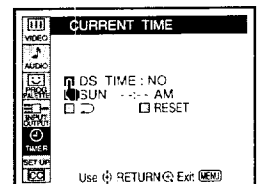
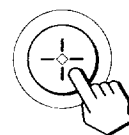

#### 4 Set the current time.

- (1) Press the joystick up or down to select time display and click the joystick. The item to be set is highlighted.

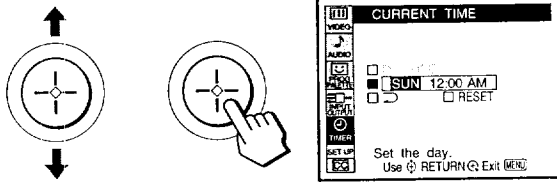

- (2) Press the joystick up or down to set the day and click the joystick.

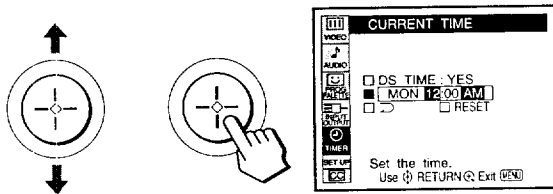

- (3) Set the hour and minute in the same way as in step (2). When you click the joystick after setting the minute, the clock starts.

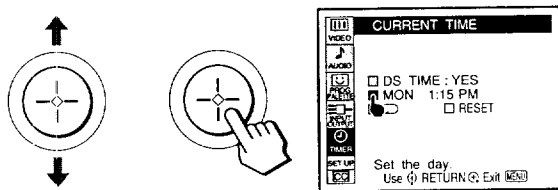

#### 5 Press the joystick up or down to select DS (Daylight Saving) TIME, and click the joystick.

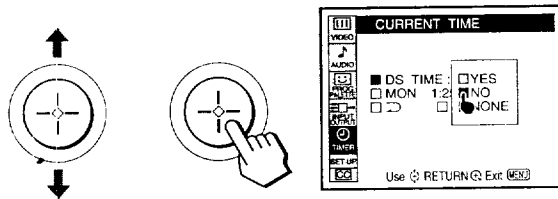

#### 6 Press the joystick up or down to select YES, NO or NONE and click the joystick.

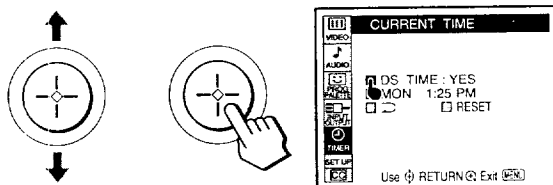

| Choose | To   |
|--------|--|
| YES    | Set for daylight saving start (set after the first Sunday in April).<br>Current time automatically moves one hour ahead. |
| NO     | Set for daylight saving end (set after the last Sunday in October).  |
| NONE   | Set if your area does not use daylight saving time.  |

#### To correct the time

While the CURRENT TIME menu is displayed, press the joystick up, down, right or left to select RESET, and then click the joystick.

#### To display the current time on the projection TV screen

Press DISPLAY.

#### Notes

- If you unplug the projection TV or a power interruption occurs, the clock setting will be erased. Reset the current time.
- If you connect a VCR using an RF cable, the projection TV may not set up the correct current time information.

## Setting your daylight saving time (DS TIME)

Make sure to set the clock before setting daylight saving time.

- 1 Press **MENU**.
- 2 Press the joystick up or down to select **TIMER** and click the joystick.
- 3 Press the joystick up or down to select **DS TIME** and click the joystick.

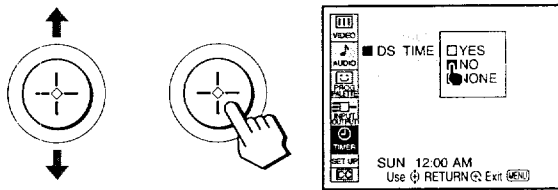

- 4 Press the joystick up or down to select **YES**, **NO** or **NONE** and click the joystick.

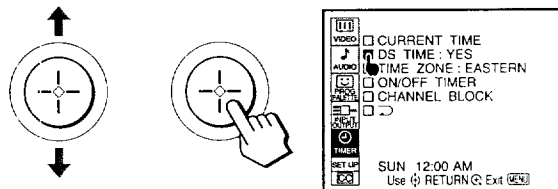

| Choose | To   |
|--------|--|
| YES    | Set for daylight saving start (set after the first Sunday in April).<br>Current time automatically moves one hour ahead. |
| NO     | Set for daylight saving end (set after the last Sunday in October).  |
| NONE   | Set if your area does not use daylight saving time.  |

## Setting the timer to turn the projection TV on and off (ON/OFF TIMER)

You can set the projection TV to turn on and off at the time you specify. Make sure the clock is set correctly. If it is not, set the clock first (page 30).

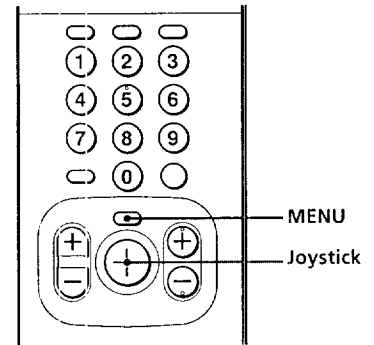

- 1 Press **MENU**.
- 2 Press the joystick up or down to select **TIMER** and click the joystick.
- 3 Press the joystick up or down to select **ON/OFF TIMER** and click the joystick.

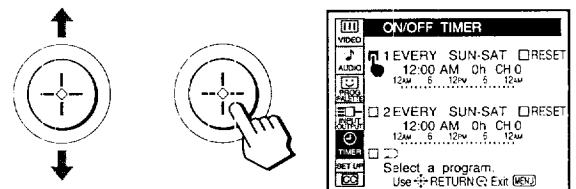

- 4 Enter the **ON/OFF TIMER** setting.

(1) Press the joystick up or down to select program 1 or 2 and click the joystick.

(2) Press the joystick up or down to set the day(s) and click the joystick. Each time you press the joystick up or down, the days cycle as shown below.

EVERY SUN-SAT → EVERY MON-FRI →  
SUNDAY → ... → SATURDAY → EVERY  
SUNDAY → ... → EVERY SATURDAY

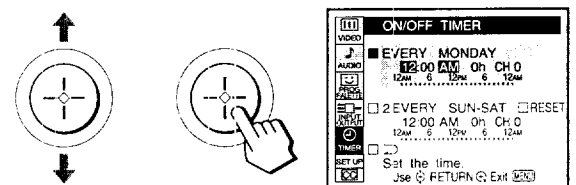



- (3) Press the joystick up or down to set the time (hour then minute) that you want to turn on the projection TV and click the joystick.

The  indicator appears indicating the turn-on time.

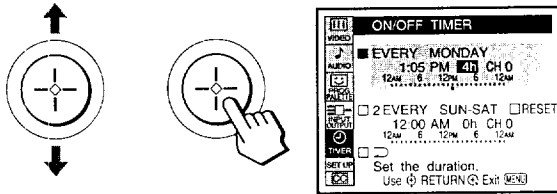

- (4) Press the joystick up or down to set the time duration and click the joystick.

Each time you click the joystick, the time duration increases by one hour up to a maximum of six hours. The bar indicator shows how long the projection TV is on.

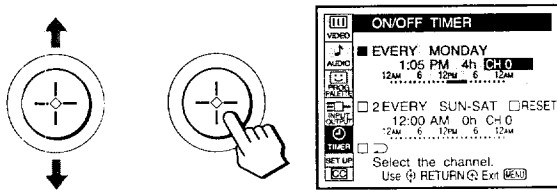

- (5) Press the joystick up or down to select the channel and click the joystick.

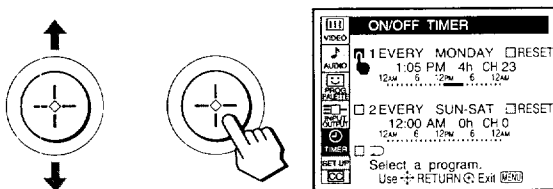

The TIMER indicator on the projection TV lights.

## 5 To set another program, click the joystick and repeat step 4.

One minute before the projection TV turns off, a message "TV will turn off." is displayed on the screen.

### To cancel the timer

While the ON/OFF TIMER is displayed, press the joystick right or left to select RESET besides the program to be reset. Then click the joystick.

### Note

- If you unplug the projection TV or a power interruption occurs, ON/OFF TIMER settings will be erased. Reset the current time, then set the timer.

## Blocking out a channel (CHANNEL BLOCK)

This feature allows you to prevent children from watching unsuitable programs. Make sure the clock is set correctly. If it is not, set the clock first (page 30).

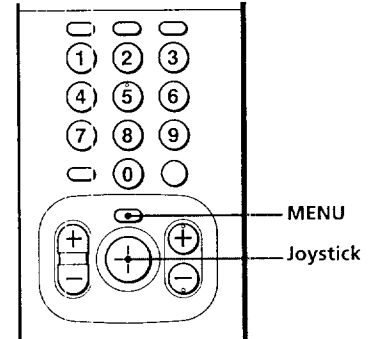

- 1 Press MENU.
- 2 Press the joystick up or down to select TIMER and click the joystick.
- 3 Press the joystick up or down to select CHANNEL BLOCK and click the joystick.

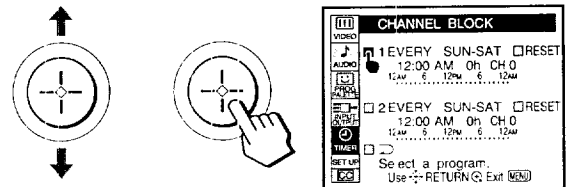

## 4 Enter a CHANNEL BLOCK setting.

- (1) Press the joystick up or down to select program 1 or 2 and click the joystick.

- (2) Press the joystick up or down to set the day(s) and click the joystick. Each time you press the joystick up or down, the days cycle as shown below.

EVERY SUN-SAT → EVERY MON-FRI → SUNDAY → ... → SATURDAY → EVERY SUNDAY → ... → EVERY SATURDAY

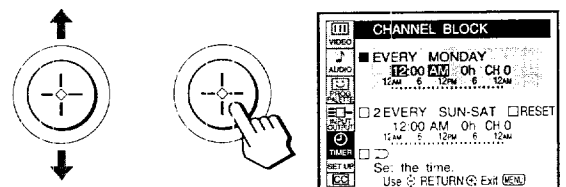

(continued)

- (3) Press the joystick up or down to set the time (hour then minute) that you want to start blocking the channel and click the joystick.

The  indicator appears indicating the time to start blocking.

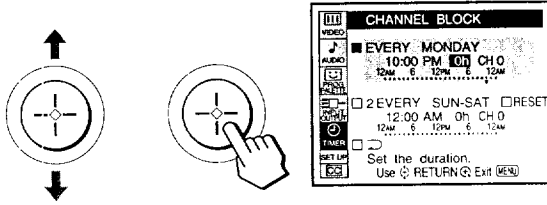

- (4) Press the joystick up or down to select the time duration you want to block and click the joystick.

Each time you click the joystick, the time duration increases by one hour up to a maximum of 12 hours. The bar indicator shows how long the projection TV is blocked out.

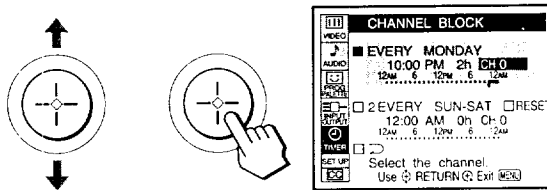

- (5) Press the joystick up or down to select the channel and click the joystick.

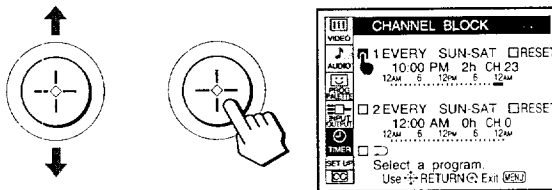

## 5 To set another program, click the joystick and repeat step 4.

If you select the blocked channel during the time you set, the message "BLOCKED" appears and the picture is blocked and the sound is muted.

### To cancel a CHANNEL BLOCK setting

While the CHANNEL BLOCK menu is displayed, press the joystick right or left to select RESET besides the program to be reset. Then click the joystick.

#### Note

- If the CHANNEL BLOCK and ON/OFF TIMER settings are overlapped, the later time setting has priority over the earlier setting.

# Using the SET UP menu

## Customizing the channel names (CH CAPTION/LOGO)

You can add a caption to up to 20 channels. This feature allows you to easily identify which channel you are watching. You can choose a broadcaster's logo (LOGO) or make your own four-letter caption (CAPTION).

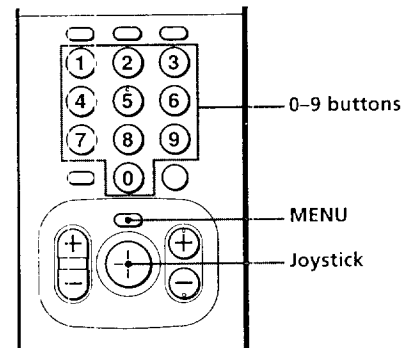

- 1 Press MENU.
- 2 Press the joystick up or down to select SET UP and click the joystick.
- 3 Press the joystick up or down to select CH CAPTION/LOGO and click the joystick.

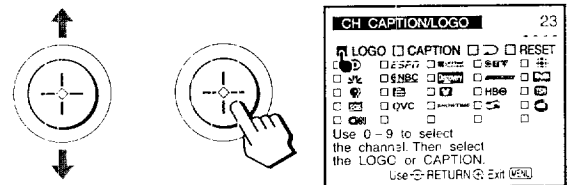

- 4 Press the 0-9 buttons to select the channel that you want to caption.

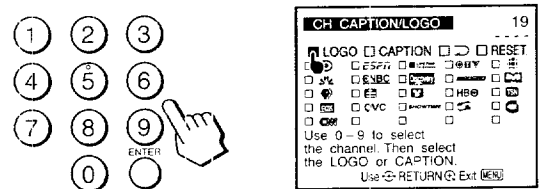

## 5 Select LOGO or CAPTION.

### To select LOGO:

- (1) Make sure that the cursor is beside LOGO, and click the joystick.

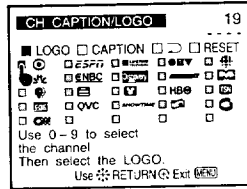

- (2) Press the joystick in any of eight directions to select the broadcaster's logo and click the joystick.

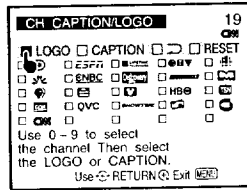
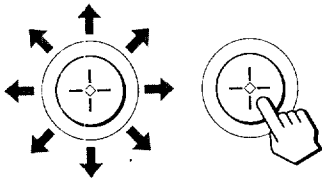

### To select CAPTION:

- (1) Press the joystick right or left to select CAPTION and click the joystick.

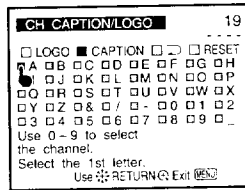
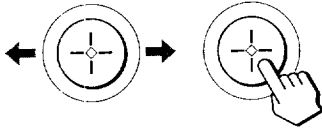

- (2) Press the joystick in any of eight directions to select the first letter.

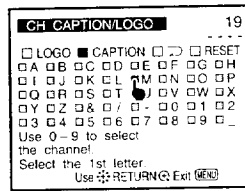
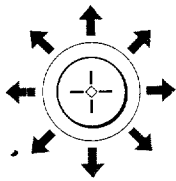

- (3) Click the joystick.

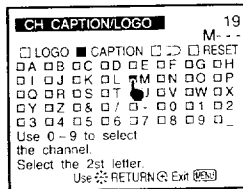
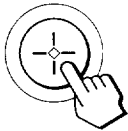

- (4) Repeat steps (2) and (3) to select the remaining letters.

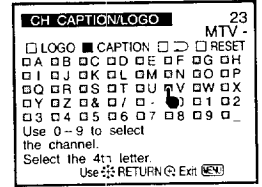
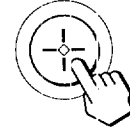
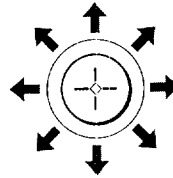

If you select fewer than three letters, move the cursor ( ) to "-" after entering the letters, and click the joystick.

## 6 Repeat steps 4 and 5 to caption other channels.

### To erase a caption

While the CH CAPTION/LOGO menu is displayed, press the joystick in any of eight directions to select RESET, then click the joystick.

### Notes

- If the CH CAPTION/LOGO menu appears in grey, the projection TV is set to a video input, and you cannot select CH CAPTION/LOGO. Press TV/VIDEO so that a channel number appears.
- If more than 90 seconds elapse after you press a button, the menu disappears automatically.
- The CH CAPTION/LOGO feature is also available for the AUX input.
- If you move the cursor to the blank spaces at the bottom of the CH CAPTION/LOGO menu when you are selecting a logo, you cannot select any logo.

## Setting your favorite channels (FAVORITE CHANNEL)

This feature allows you to select your favorite channels (up to eight channels) easily while displaying them on the screen at the same time.

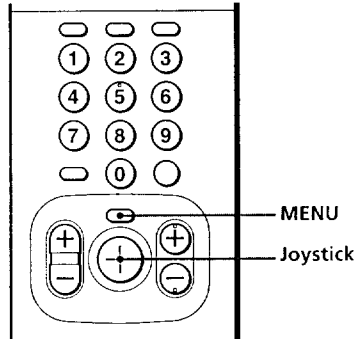

- 1 Press MENU.**
- 2 Press the joystick up or down to select SET UP and click the joystick.**
- 3 Press the joystick up or down to select FAVORITE CHANNEL and click the joystick.**

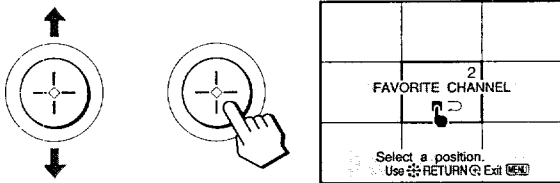

- 4 Press the joystick in any of eight directions to select the position in the FAVORITE CHANNEL screen, then click the joystick.**  
The current channel is displayed in the selected position.

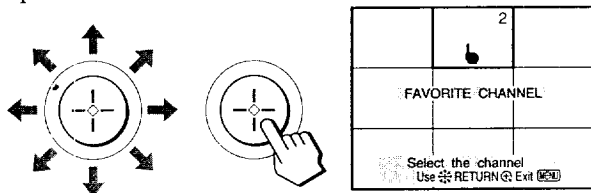

- 5 Press the joystick up or down to select the desired channel and click the joystick.**  
The new channel is stored in the FAVORITE CHANNEL screen in the selected position.

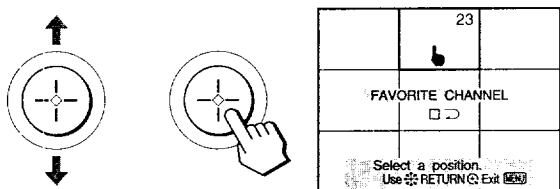

- 6 Repeat steps 4 and 5 to set other favorite channels.**

### Note

- If you set TV INPUT to any option other than OFF, you cannot use the FAVORITE CHANNEL feature.

## Selecting a favorite channel

After you set your favorite channels, you can select a channel you want while displaying all your favorite channels on the projection TV screen at the same time.

- 1 Click the joystick.**

Eight window pictures of your favorite channels appear on the screen with the full-motion picture of the currently selected channel in the center.

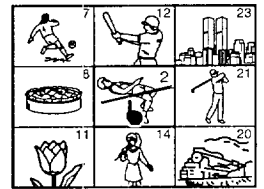
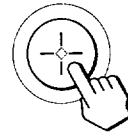

- 2 Press the joystick to move the cursor to the channel you want to watch.**

The joystick of the remote commander lets you select any picture with a press.

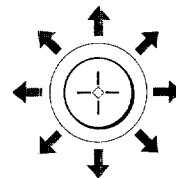

- 3 Click the joystick.**

The picture of the selected channel is displayed on the screen.

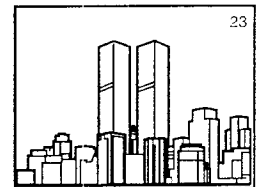
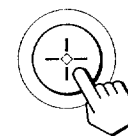

## Selecting a VCR input directly (DIRECT PLAY)

The DIRECT PLAY feature allows you to switch from TV input to VCR input mode by pressing the ► (playback) button on the supplied remote commander. For example, connect your VCR to the VIDEO 1 IN jacks and set the VTR1 2 3 MDP selector located beneath the lid of the remote commander to VTR2. After completing the procedure below, the input mode is switched to the VCR connected to the VIDEO 1 IN jacks when you press the ► button.

- 1 Press MENU.
- 2 Press the joystick up or down to select SET UP, and click the joystick.
- 3 Press the joystick up or down to select DIRECT PLAY and click the joystick.

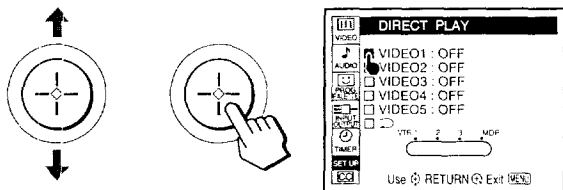

- 4 Press the joystick up or down to select the input to which the video equipment is connected and click the joystick.

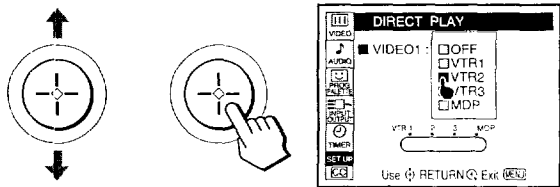

- 5 Press the joystick up or down to select the position of the VTR1 2 3 MDP selector and click the joystick.

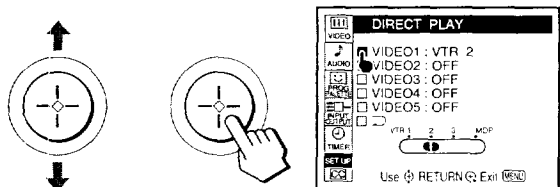

## Customizing the pointer (CUSTOMIZED POINTER)

You can choose the desired cursor (pointer) from among eight different designs and/or colors.

- 1 Press MENU.
- 2 Press the joystick up or down to select SET UP and click the joystick.
- 3 Press the joystick up or down to select CUSTOMIZED POINTER and click the joystick.

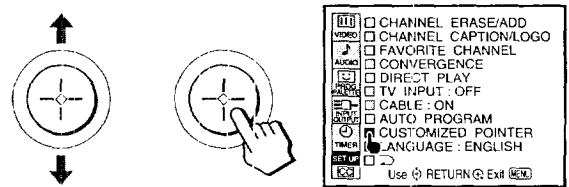

- 4 Press the joystick in any of eight directions to select the desired cursor and click the joystick.

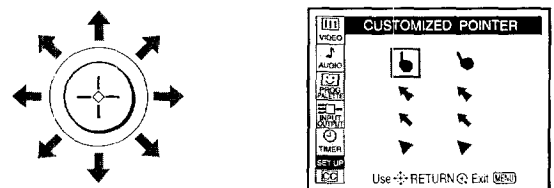

# Displaying Caption Vision/XDS

## (CAPTION VISION/XDS)

### To display Caption Vision

Press DISPLAY. (See page 20 for details.)

#### Notes

- Poor reception of TV programs can cause errors in Caption Vision and XDS.
- Captions may appear with a white box or other errors instead of a certain word.
- XDS, Caption Vision, and the status display cannot be used at the same time.
- For details on XDS, see page 20.

Some programs are broadcast with Caption Vision. To display Caption Vision, select either CC1, CC2, CC3, CC4, TEXT1, TEXT2, TEXT3 or TEXT4 from the menu. CC1, CC2, CC3 or CC4 shows you a caption, that is a printed version of the dialog or sound effects of a program. (The mode should be set to CC1 for most programs.)

TEXT1, TEXT2, TEXT3 or TEXT4 shows you text, that is information presented using either half or the whole screen. It is not usually related to the program.

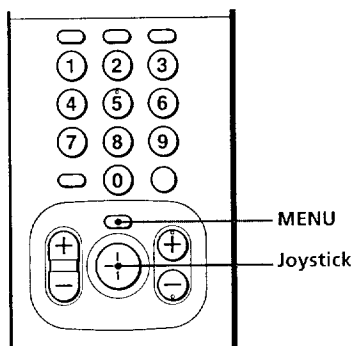

**1 Press MENU.**

**2 Press the joystick up or down to select  and click the joystick.**

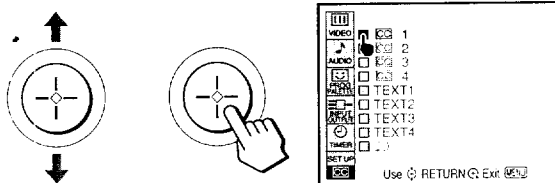

**3 Press the joystick up or down to select the caption type and click the joystick.**

The selected caption type is colored green.

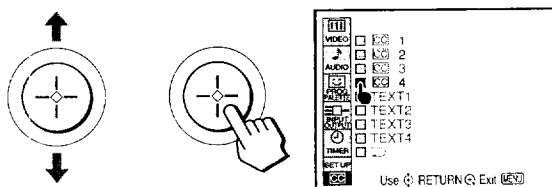

# Operating video equipment

You can program the supplied remote commander to operate video equipment that have an infrared remote sensor. For programming, set the manufacturer's code number. You can set the manufacturer's code to each of four positions of the VTR1 2 3 MDP selector, so that you can operate four different pieces of equipment.

## Setting the manufacturer's code

The following Sony video equipment is assigned to each position of the VTR1 2 3 MDP selector at its factory preset:

VTR1 Beta, ED Beta VCRs  
 VTR2 8 mm VCR  
 VTR3 VHS VCR  
 MDP Multi-disc player

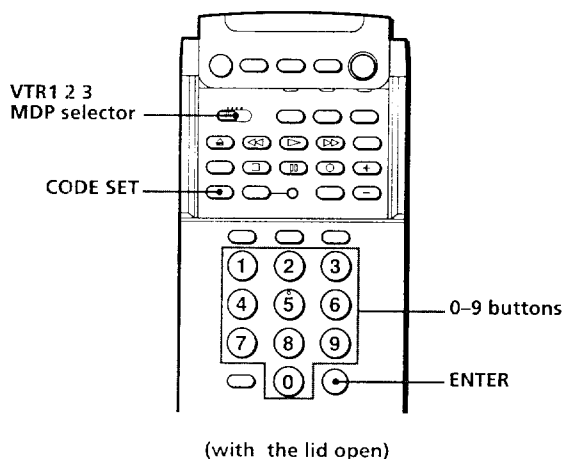

### Note

- To use another manufacturer's equipment besides a Sony VCR, set the selector to a position not being used for your Sony VCR.

**1 Turn off the equipment you want to set up.**

**2 Open the lid, then set the VTR1 2 3 MDP selector to the position you want to set the code.**

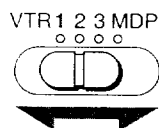

**3 Press CODE SET, then press 0 - 9 to enter the manufacturer's code number (see the chart below) and press ENTER. For example, to operate a Sony 8 mm VCR, press CODE SET, 3, 0, 2 and ENTER.**

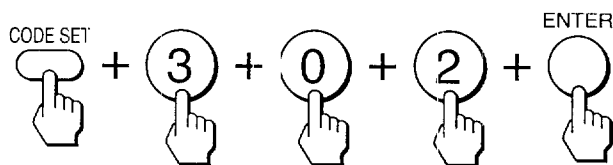

## VCR manufacturer code numbers

| Manufacturer             | Code number                            |
|--------------------------|--|
| Sony                     | 301, 302, 303                          |
| Aiwa                     | 338                                    |
| Audio Dynamic            | 314, 337                               |
| Bell & Howell (M. Wards) | 330, 343                               |
| Brocsonic                | 319                                    |
| Canon                    | 309, 303                               |
| Citizen                  | 332                                    |
| Craig                    | 315, 302, 332                          |
| Curtis Mathis            | 304, 338, 309                          |
| Daewoo                   | 341, 312, 309                          |
| DBX                      | 314, 336, 337                          |
| Dimensia                 | 304                                    |
| Emerson                  | 319, 320, 316, 317, 318                |
| Fisher                   | 330, 334, 335, 333                     |
| Funai                    | 338                                    |
| General Electric         | 329, 304, 309                          |
| Goldstar                 | 332                                    |
| Hitachi                  | 306, 304, 305                          |
| Instant Replay           | 309, 308                               |
| JC Penney                | 309, 305, 304, 330, 314, 336, 337      |
| JVC                      | 314, 336, 337                          |
| Kenwood                  | 314, 336, 332, 337                     |
| LXI (Sears)              | 332, 305, 333, 334, 330, 335           |
| Magnavox                 | 310, 308, 309                          |
| Marantz                  | 314, 336, 337                          |
| Marta                    | 332                                    |
| Memorex                  | 309, 335                               |
| Minolta                  | 305, 304                               |
| Mitsubishi/MGA           | 323, 324, 325, 326                     |
| Multitech                | 325, 338, 321                          |
| NEC                      | 314, 336, 337                          |
| Olympic                  | 309, 308                               |
| Panasonic                | 308, 309, 306, 307                     |
| Pentax                   | 305, 304                               |
| Philco                   | 308, 309                               |
| Philips                  | 310, 308, 309                          |
| Pioneer                  | 308                                    |
| Quasar                   | 308, 309                               |
| RCA/PROSCAN              | 304, 305, 308, 309, 310, 311, 312, 313 |

(continued)

## VCR manufacturer code numbers

| Manufacturer              | Code number                            |
|---------------------------|--|
| Realistic                 | 309, 330, 328, 335, 324, 338           |
| Sansui                    | 314                                    |
| Singer                    | 315                                    |
| Samsung                   | 322, 313, 321                          |
| Sanyo                     | 330, 335                               |
| Scott                     | 312, 313, 321, 335, 323, 324, 325, 326 |
| Sharp                     | 327, 328                               |
| Shintom                   | 315                                    |
| Signature 2000 (M. Wards) | 338, 327                               |
| Sylvania                  | 310, 308, 309, 338                     |
| Symphonic                 | 338                                    |
| Tashiro                   | 332                                    |
| Tatung                    | 314, 336, 337                          |
| Teac                      | 314, 336, 338, 337                     |
| Technics                  | 309, 308                               |
| Toshiba                   | 312, 311                               |
| Wards                     | 327, 328, 335, 331, 332                |
| Yamaha                    | 330, 314, 336, 337                     |
| Zenith                    | 331                                    |

## MDP manufacturer code numbers

| Manufacturer | Code number |
|--------------|-------------|
| Sony         | 701         |
| Kenwood      | 707         |
| Magnavox     | 703         |
| Maranz       | 702         |
| Mitsubishi   | 702         |
| Panasonic    | 704         |
| Philips      | 703         |
| Pioneer      | 702         |
| RCA          | 702         |
| Sanyo        | 706         |
| Sharp        | 705         |
| Yamaha       | 703         |

### Notes

- If more than one code number is listed, try entering them one by one, until you come to the correct code for your equipment.
- In some rare cases, you may not be able to operate your non-Sony video equipment with this remote commander. This is because your equipment may use a code that is not provided with this remote commander. In this case, please use the equipment's own remote control unit or use the learning function (page 42).
- The code numbers for Sony equipment are assigned at the factory as follows:
 

|                    |     |
|--------------------|-----|
| VHS VCR            | 301 |
| 8 mm VCR           | 302 |
| Beta, ED Beta VCRs | 303 |
| Multi-disc player  | 701 |

### Caution

- Whenever you remove the batteries — to replace them, for example — if too much time is taken, the code numbers revert to the factory settings and must be reset.

## Operating video equipment

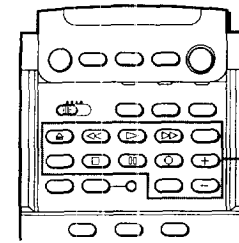

(with the lid open)

- 1 Set the VTR1 2 3 MDP selector to the position you set for the video equipment.

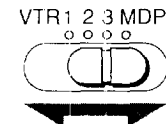

- 2 Use the video operating buttons on the remote commander to operate the video equipment.

| Operating a VCR                           | Buttons on the remote commander                |
|---|--|
| To turn on or off                         | Press POWER                                    |
| To change channels                        | Press CH +/-                                   |
| To record                                 | Press ● and REC simultaneously                 |
| To play                                   | Press ►  |
| To stop                                   | Press ■  |
| To fast forward                           | Press ►►                                       |
| To rewind the tape                        | Press ◄◄                                       |
| To pause                                  | Press  |
|   | To resume normal playback, press again.        |
| To search the picture forward or backward | Press ►► or ◄◄ during playback                 |
|   | To resume normal playback, release the button. |
| To change input mode                      | Press TV/VTR                                   |
| To eject a cassette                       | Press ▲ (Used only with Sony brand products)   |

| Operating a multi-disc player              | Buttons on the remote commander                |
|--|--|
| To turn on or off                          | Press POWER                                    |
| To play                                    | Press ►  |
| To stop                                    | Press ■  |
| To pause                                   | Press  |
|  | To resume normal playback, press again.        |
| To search the picture forward or backward  | Keep pressing ►► or ◄◄ during playback         |
|  | To resume normal playback, release the button. |
| To search the chapter forward and backward | Press CH +/-                                   |
| To eject a disc                            | Press ▲ (Used only with Sony brand products)   |

### Note

- If the video equipment does not have a certain function, the corresponding button on this remote commander will not operate.



# Operating a cable box or DBS receiver

You can program the supplied remote commander to operate a cable box or DBS receiver. Follow the procedures below to set the manufacturer's code number to operate it.

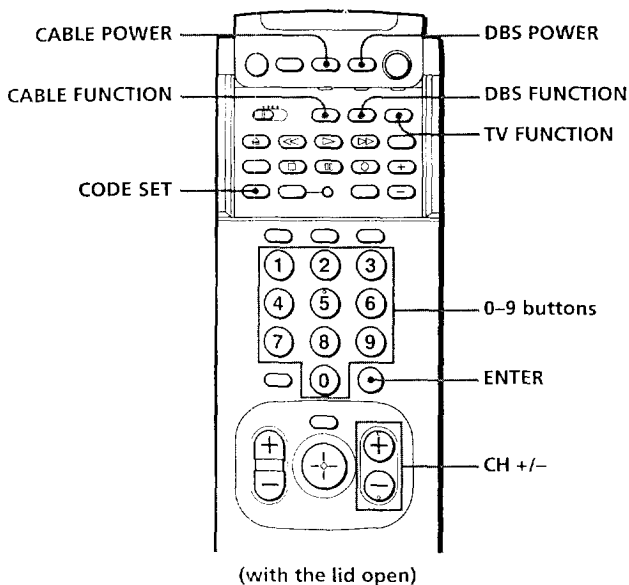

**1 Turn off the equipment you want to set up and press FUNCTION of the equipment you want to set up (CABLE or DBS).**

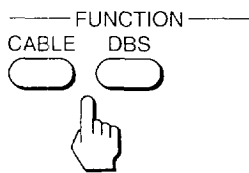

**2 Press CODE SET, then press 0 - 9 to enter the manufacturer's code number (see the chart below) and press ENTER. For example, to program your remote commander to operate a Zenith cable box, press CODE SET, 2, 1, 2 and ENTER.**

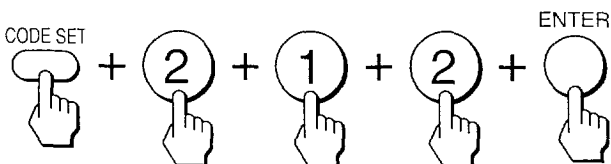

**3 Press CABLE POWER to turn on a cable box or DBS POWER when you use a DBS receiver.**

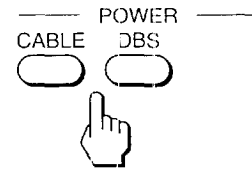

**4 Use the projection TV control buttons to check if your code number works.**

For example, to operate a cable box, you can use the CABLE POWER, JUMP, CH +/-, 0-9 and ENTER buttons.

To operate a DBS receiver, you can use the DBS POWER, JUMP, DISPLAY, MENU and 0-9 buttons, and the joystick.

## To operate the projection TV

Press TV FUNCTION. Then use the projection TV control buttons to control the projection TV.

## For more details on operating the cable box or DBS receiver

Refer to the operating instructions that come with the equipment.

## If the remote commander doesn't work

- First, try repeating the setup procedures using the other codes listed for your equipment.
- If — after trying all the codes listed for your equipment — you still cannot get the remote commander to work properly, try the learning function described on page 42.

## Manufacturer code numbers (cable box)

| Manufacturer       | Code number                                 |
|--------------------|---|
| Hamlin/Regal       | 222, 223, 224, 225, 226                     |
| Jerrold/G. I.      | 201, 202, 203, 204, 205, 206, 207, 208, 218 |
| Oak                | 227, 228, 229                               |
| Panasonic          | 219, 220, 221                               |
| Pioneer            | 214, 215                                    |
| Scientific Atlanta | 209, 210, 211                               |
| Tocom              | 216, 217                                    |
| Zenith             | 212, 213                                    |

## Manufacturer code numbers (DBS receiver)

| Manufacturer | Code number |
|--------------|-------------|
| Sony         | 801         |
| RCA          | 802         |

## Notes

- If more than one code number is listed, try entering them one by one until you come to the correct code for your equipment.
- If you enter a new code number, the code number you previously entered at that setting is erased.
- In some rare cases, your equipment may use a code that is not provided with this remote commander and you may not be able to operate your equipment with the supplied remote commander. In this case, use the equipment's own remote control unit or use the learning function (page 42).
- Whenever you remove the batteries — to replace them, for example — if too much time is taken, the code numbers revert to the factory settings and must be reset.

# Operating non-preprogrammed equipment — Learning function

You can program the supplied remote commander to learn the functions of another remote commander. Use this function to operate equipment whose manufacturer's code is not preprogrammed, such as Sony or other manufacturers' audio equipment or other equipment whose manufacturer's code is not listed on pages 39 – 41.

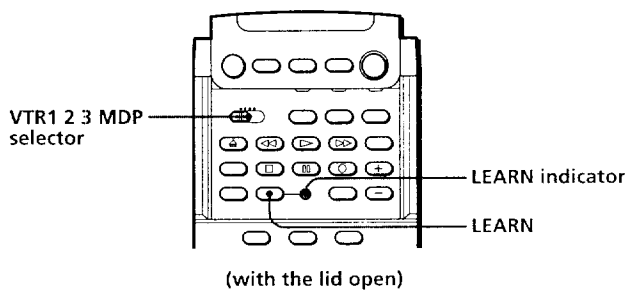

## 1 Set the VTR1 2 3 MDP selector to VTR3 or MDP.

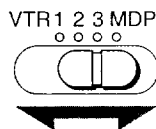

## 2 Place the supplied remote commander and the other equipment's remote commander directly facing each other, approximately 5 cm (2 inches) apart.

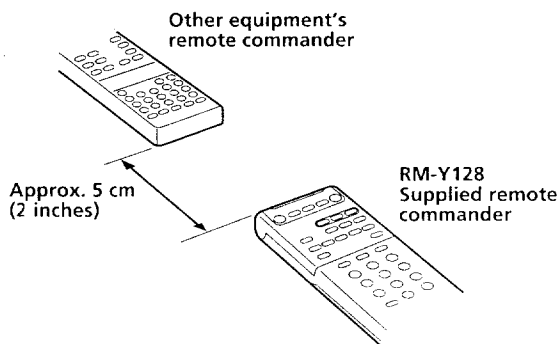

## 3 Press and release the LEARN button.

The LEARN indicator lights up.

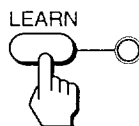

## 4 Press and release the button on the supplied remote commander that will learn the function.

The LEARN indicator flashes off and then on again, indicating that the remote commander is ready to learn.

## 5 Hold down the corresponding button on the other remote commander and release the button when the LEARN indicator flashes off then on again.

When the LEARN indicator flashes off and then on again, this indicates that learning is complete. If not, repeat steps 4 and 5.

## 6 Repeat steps 4 and 5 to learn other functions.

## 7 Press LEARN.

The LEARN indicator goes off, indicating that learning is complete.

### Notes

- The LEARNING function does not work in VTR1 or VTR2 setting.
- Do not move the remote commanders during learning.
- If you press a button of the supplied remote commander that cannot be used for learning in learning mode, the LEARN indicator flashes four times.
- If the other remote commander's signal cannot be learned, the LEARN indicator flashes four times.
- To clear all learned signals from memory, set the VTR1 2 3 MDP selector to MDP, press LEARN, then press TV POWER while holding down VOL -. Then press LEARN again.

### Caution

- Whenever you remove the batteries — to replace them, for example — if too much time is taken, the code numbers revert to the factory settings and must be reset.

# Troubleshooting

After trying the methods below, if the problem persists, contact your nearest Sony dealer.

### No picture (screen not lit), no sound

- Make sure the power cord is connected securely.
- Check to see if the TV/VIDEO setting is correct: when watching TV, set to TV, and when watching video tapes, set to VIDEO. (pages 19, 21)
- Before you use the projection TV, cable box or DBS receiver, make sure to press the corresponding FUNCTION button on the remote commander. (pages 19, 41)
- Try another channel. It could be station trouble.

### Poor or no picture (screen lit), good sound

- Adjust PICTURE in the VIDEO menu. (page 23)
- Adjust BRIGHT in the VIDEO menu. (page 23)
- Adjust the convergence. (page 16)
- Check antenna/cable connections. (page 6)

### Good picture, no sound

- Press MUTING so that "MUTING" disappears from the screen. (page 20)
- Check the MTS setting in the AUDIO menu. (page 27)
- Make sure SPEAKER is set to ON in the AUDIO menu. (page 27)

### No color

- Adjust COLOR in the VIDEO menu. (page 23)
- Confirm that a black and white program is not being broadcast.

### Only snow and noise appear on the screen

- Check the CABLE setting in the SET UP menu. (page 16)
- Check the antenna/cable connections. (page 6)
- Make sure the channel is broadcasting programs.

### Dotted lines or stripes

- Adjust the antenna.
- Move the projection TV away from noise sources such as cars, neon signs, and hair-dryers.

### Double images or ghosts

- Use a highly directional outdoor antenna or a cable (when the problem is caused by reflections from nearby mountains or tall buildings.)

### Cannot operate menu

- If the item you want to choose appears in grey, you cannot select it. Press TV/VIDEO correctly.
- Check the CABLE setting in the SET UP menu. (page 16)

### Cannot receive upper channels (UHF) when using an antenna

- Check if CABLE is OFF in the SET UP menu. (page 16)
- Use AUTO PROGRAM to add receivable channels that are not presently in the memory. (page 17)

### Cannot receive any channels when using cable TV

- Check if CABLE is ON in the SET UP menu. (page 16)
- Use AUTO PROGRAM to add receivable channels that are not presently in the memory. (pages 17)

### Remote commander does not operate

- Battery could be weak. Replace the battery. (page 13)
- Make sure the projection TV's power cord is connected securely to wall outlet.
- Press TV FUNCTION when operating your projection TV.
- Are fluorescent lights too close to the projection TV? Move lights at least 3 - 4 feet away from the projection TV.

(continued)

**Some of the remote commander's buttons do not function**

- ➔ Press the correct FUNCTION button according to the equipment you operate. (pages 19, 40)

**Cannot gain enough volume when using a cable box**

- ➔ Increase the volume at the cable box. Then press TV FUNCTION and adjust the projection TV's volume. (page 41)

**The current time resets whenever the projection TV is turned on**

- ➔ Connect the projection TV's and the cable box's AV power cords to separate wall outlets.

**Cannot operate the 0-9 buttons, CH +/-, TV/VIDEO and ANT/AUX buttons on the remote commander.**

- ➔ Select TV OUT in the INPUT/OUTPUT menu and enter NO. (page 29)

# Specifications

|  |  |
|--|--|
| <b>Projection system</b>                 | 3 picture tubes, 3 lenses, horizontal in-line system   |
| <b>Picture tube</b>                      | 7-inch high-brightness monochrome tubes (6.3 raster size), with optical coupling and liquidcooling system  |
| <b>Projection lenses</b>                 | High performance, large diameter hybrid lens F1.0  |
| <b>Screen size (measured diagonally)</b> | 53 inches  |
| <b>Screen brightness</b>                 | 900 cd/m <sup>2</sup>  |
| <b>Television system</b>                 | American TV standard   |
| <b>Channel coverage</b>                  | VHF: 2-13/UHF: 14-69/CATV: 1-125   |
| <b>Antenna</b>                           | 75-ohm external antenna terminal for VHF/UHF   |
| <b>Inputs/outputs</b>                    | VIDEO 1/3/4/5 IN and VIDEO 2 INPUT<br>S VIDEO IN (4-pin mini DIN):<br>Y: 1 Vp-p, 75-ohms unbalanced, sync negative<br>C: 0.286 Vp-p (Burst signal), 75 ohms<br>VIDEO (phono jack): 1 Vp-p, 75-ohms unbalanced, sync negative<br>AUDIO (phono jacks): 500 mVrms (100% modulation), Impedance : 47 kilohms<br>SELECT OUT<br>VIDEO (phono jack): 1 Vp-p, 75 ohms unbalanced, sync negative<br>AUDIO (phono jacks): 470 mVrms (100% modulation), Impedance: 75 kilohms |

|                             |   |
|-----------------------------|---|
|                             | AUDIO (VAR) OUT (phono jacks): 760 mVrms (100% modulation)  |
|                             | AUDIO (FIX) OUT (phono jacks): 500 mVrms (100% modulation)  |
|                             | CONTROL S IN/OUT mini jacks   |
| <b>Speaker</b>              | Full range speakers<br>100 mm (3.9 inches) diameter   |
| <b>Speaker output</b>       | 10 W × 2  |
| <b>Power requirement</b>    | 120 V, 60 Hz  |
| <b>Power consumption</b>    | 240 W<br>Standby mode: 4 W  |
| <b>Dimensions</b>           | 1,164 × 1,443 × 630.6 mm<br>(45 <sup>7</sup> / <sub>8</sub> × 56 <sup>7</sup> / <sub>8</sub> × 24 <sup>7</sup> / <sub>8</sub> inches) |
| <b>Mass</b>                 | 100.4 kg (22 lb 5 oz)   |
| <b>Supplied accessories</b> | Remote commander RM-Y128 (1)<br>Size AA (R6) battery (2)  |
| <b>Optional accessories</b> | U/V mixer EAC-66<br>Connecting cables RK-74A,<br>VMC-810S/820S, YC-15V/30V  |











Design and specifications are subject to change without notice.

# Index

Adjusting  
    convergence 16  
    the picture 23  
    the sound 26  
Antenna 6  
Auto program 14, 17  
Battery 13  
Cable box 41  
Cable TV 16  
Caption Vision 20, 38  
Changing the menu language 17  
Channel block 33  
Channel Caption/logo 34  
Connection  
    with a DBS receiver 9  
    with a VCR 7, 8  
    with an antenna 6  
    without a VCR 6  
DEMO 14  
Dolby Pro-Logic 11  
DBS receiver 9, 41  
Erase/add 15  
Joystick 13  
Jump 19  
MTS (Multichannel TV Sound) 27  
Muting 20  
P&P (Picture-and-Picture) 21  
PIP (Picture-in-picture) 21  
Presetting channels 14, 17  
PROGRAM PALETTE 27  
Remote commander 13  
S video 8  
SAP (Second Audio Program) 27  
Setting  
    daylight saving time 31, 32  
    the clock 30  
Sleep timer 20  
STEREO indicator 27

TIMER indicator 33  
Twin View™ 21  
Video label 30  
Watching  
    TV 19  
    video tapes 21  
XDS 20, 38

## Names of controls

 (channel index) button 23  
 (P&P) button 21  
 (PIP) button 21  
ANT/AUX button 21  
AUDIO button 22  
AUDIO L(MONO)/R IN jacks 7–10, 12  
AUDIO (FIX) OUT jacks 11  
AUDIO (VAR) OUT jacks 11  
CENTER SPEAKER IN terminals 11  
CH(channel) +/- buttons 15, 19  
CODE SET button 39  
CONTROL S jacks 12  
DISPLAY button 20  
ENTER button 19, 39  
FREEZE button 23  
FUNCTION (CABLE) button 41  
FUNCTION (DBS) button 41  
FUNCTION (TV) button 19  
Joystick 13  
JUMP button 19  
MENU button 13  
MUTING button 20  
PIP CH (channel) +/- buttons 22  
PIP OFF button 21  
PIP TV/VIDEO button 22  
POSITION button 22  
POWER (CABLE) button 41  
POWER (DBS) button 41  
POWER (TV) button 19  
S VIDEO input jacks 8  
SELECT OUT jacks 10, 12  
SLEEP button 20  
SWAP button 22  
TV/VIDEO button 14, 21  
VTR (POWER, CH +/-, , , , , , , ,  
REC, TV/VTR) buttons 40  
VHF/UHF antenna terminal 6, 7  
VIDEO 1/3/4/5 IN jacks 7–10  
VIDEO 2 INPUT jacks 10  
VOL (volume) +/- buttons 19





***Color Rear Video  
Projector***