

 MITSUBISHI

**HS-U760**

Video  
Cassette  
Recorder  
Owner's  
Guide

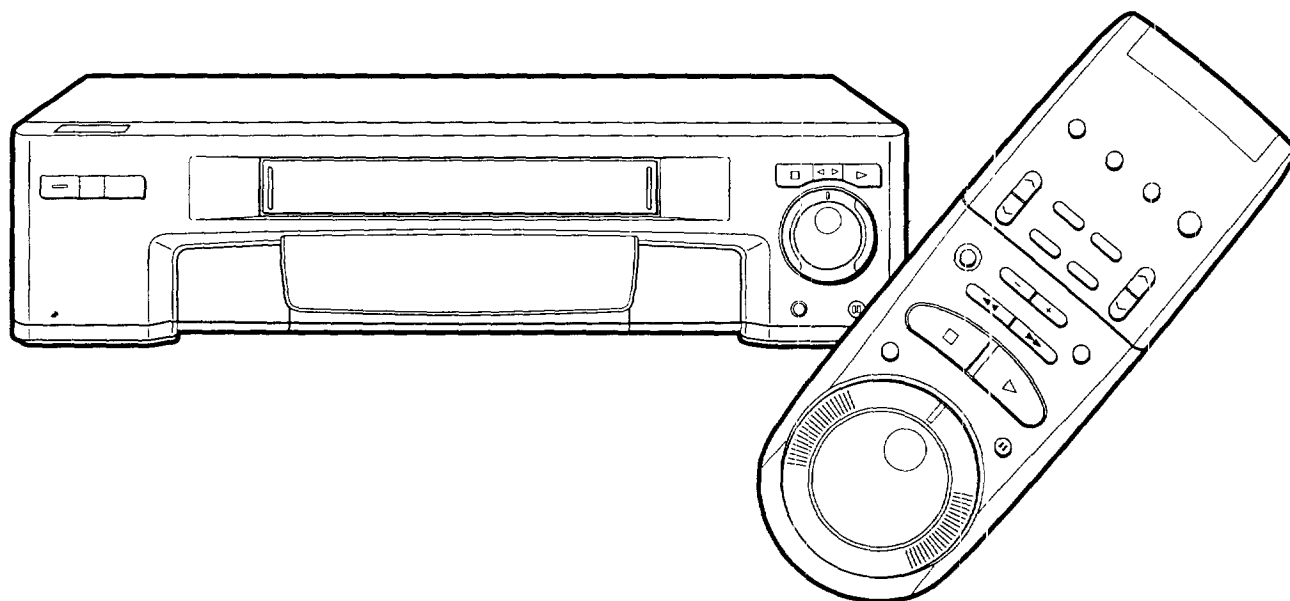

**VCR Plus+**  
w/Cable Channel  
Changer

VCR Plus+ and PlusCode are trademarks of Gemstar Development Corp. VCR Plus+ system is manufactured under license from Gemstar Development Corporation.

**S VHS**

This Video Cassette Recorder is based on the S-VHS and VHS formats. Only video cassette tapes with the **SVHS** mark or the **VHS** mark may be used with this model.

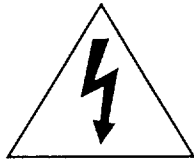

## CAUTION

RISK OF ELECTRIC SHOCK  
DO NOT OPEN



**CAUTION:** TO REDUCE THE RISK OF ELECTRIC SHOCK,  
DO NOT REMOVE COVER (OR BACK).  
NO USER-SERVICEABLE PARTS INSIDE.  
REFER SERVICING TO QUALIFIED SERVICE PERSONNEL.

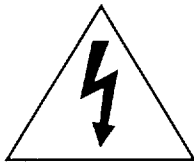

The lightning flash with arrowhead symbol, within an equilateral triangle, is intended to alert the user to the presence of uninsulated “dangerous voltage” within the product’s enclosure that may be of sufficient magnitude to constitute a risk of electric shock.



The exclamation point within an equilateral triangle is intended to alert the user to the presence of important operating and maintenance (servicing) instructions in the literature accompanying the appliance.

### **IMPORTANT:**

RECORDING OF COPYRIGHTED TELEVISION PROGRAMS MAY VIOLATE COPYRIGHT LAW.

### **WARNING:**

TO PREVENT FIRE OR SHOCK HAZARD, DO NOT EXPOSE THIS APPLIANCE TO RAIN OR MOISTURE.

### **CAUTION:**

TO PREVENT ELECTRIC SHOCK HAZARD, DO NOT USE THIS (POLARIZED) PLUG WITH AN EXTENSION CORD, RECEPTACLE OR OTHER OUTLET UNLESS THE BLADES CAN BE FULLY INSERTED TO PREVENT BLADE EXPOSURE.

### **NOTE TO CATV SYSTEM INSTALLER:**

THIS REMINDER IS PROVIDED TO CALL THE CATV SYSTEM INSTALLER’S ATTENTION TO ARTICLE 820-40 OF THE NEC THAT PROVIDES GUIDELINES FOR PROPER GROUNDING AND, IN PARTICULAR, SPECIFIES THAT THE CABLE GROUND SHALL BE CONNECTED TO THE GROUNDING SYSTEM OF THE BUILDING, AS CLOSE TO THE POINT OF CABLE ENTRY AS PRACTICAL.



# Table of Contents

<b>Important Safeguards</b> .....	2	Descriptions of video functions .....	30
<b>Preface</b>		Using the Menus to Set the Time .....	31
<b>Welcome to Mitsubishi</b> .....	5	Programming the VCR to Receive TV	
Unpacking Your VCR .....	5	Channels .....	33
<b>Chapter One</b>		Programming channels automatically ..	33
<b>Getting to Know Your VCR</b> .....	6	Using video mute .....	36
Front Panel Buttons and Functions .....	6	Adding and deleting channels .....	36
Fluorescent Display .....	7	Selecting a channel .....	37
Overview of the Remote Control .....	9	Setting the VCR Plus+ Guide Channel	
Rear Panel Terminals .....	11	Numbers .....	38
<b>Chapter Two</b>		Recording .....	40
<b>Connecting Your VCR</b> .....	12	Recording a current broadcast .....	40
Connecting the Antenna or Cable		Programming your VCR to record .....	41
to the VCR .....	12	Programming with VCR Plus+ .....	44
Connecting cable antennas .....	12	Using Quick Program .....	45
Connecting other antennas .....	13	Using One-Touch Recording (OTR) .....	46
Connecting separate UHF/VHF		Using One Key Programming .....	47
antennas .....	14	Notes about programmed recording .....	50
Connecting the Television .....	15	<b>Chapter Four</b>	
Determining if you need a splitter .....	15	<b>Using the Advanced Features</b> .....	53
Connecting a regular TV to the VCR .....	16	Using the Advanced Playback Controls .....	53
Connecting a TV with audio and		Using special effects .....	53
video inputs .....	17	Adjusting the tracking .....	54
Connecting a Satellite Receiver (optional) ..	18	Using the time counter .....	55
Connecting the A/V Network (optional) .....	19	Using the Advanced Recording Controls ..	55
<b>Chapter Three</b>		Using the PerfectTape™ feature .....	56
<b>Operating Your VCR</b> .....	21	Displaying the time gauge and the	
Setting Up Your VCR for the First Time ..	21	remaining time .....	57
Setting up your VCR if you are using a		Displaying the present time .....	58
regular TV .....	21	Searching Techniques .....	58
Setting up your VCR if you are using a		Quick searching .....	58
monitor TV .....	22	Edit searching .....	59
Using the Remote Control .....	22	Speed searching .....	59
Using the remote control to operate		Searching by time .....	60
the VCR .....	22	Searching for a blank portion of tape ..	61
Using the remote control to operate		Index search techniques .....	61
the TV .....	23	Using the Active A/V Network Features ..	64
Viewing the Picture Coming from		Making a Copy of a Tape .....	66
Your VCR .....	25	Using your HS-U760 to record from	
Loading and Unloading Tapes .....	26	another VCR .....	66
Playing a Tape .....	27	Using your HS-U760 to play back to	
Playing back a tape .....	27	another VCR .....	67
Using basic playback controls .....	27	Using edit control .....	68
Selecting the On-screen Language .....	28	Using Child Lock .....	69
Using the Audio and Video Functions .....	28	<b>Chapter Five</b>	
Selecting and adjusting the audio and		<b>Troubleshooting</b> .....	70
video functions .....	29	<b>Index</b> .....	71
Descriptions of audio functions .....	29		

---

# IMPORTANT SAFEGUARDS

PLEASE READ ALL THESE INSTRUCTIONS REGARDING YOUR VCR AND RETAIN FOR FUTURE REFERENCE. FOLLOW ALL WARNINGS AND INSTRUCTIONS MARKED ON THE VCR.

1. **Read Instructions**  
All the safety and operating instructions should be read before the appliance is operated.
2. **Retain Instructions**  
The safety and operating instructions should be retained for future reference.
3. **Heed Warnings**  
All warnings on the appliance and in the operating instructions should be adhered to.
4. **Follow Instructions**  
All operating and use instructions should be followed.
5. **Cleaning**  
Unplug this video product from the wall outlet before cleaning. Do not use liquid cleaners or aerosol cleaners. Use a damp cloth for cleaning.
6. **Attachments**  
Do not use attachments not recommended by the video product manufacturer as they may cause hazards.
7. **Water and Moisture**  
Do not use this video product near water — for example, near a bath tub, wash bowl, kitchen sink, or laundry tub, in a wet basement, or near a swimming pool, and the like.
8. **Accessories**  
Do not place this video product on an unstable cart, stand, tripod, bracket, or table. The video product may fall, causing serious injury to a child or adult, and serious damage to the appliance. Use only with a cart, stand, tripod, bracket, or table recommended by the manufacturer, or sold with the video product. Any mounting of the appliance should follow the manufacturer's instructions, and should use a mounting accessory recommended by the manufacturer.

An appliance and cart combination should be moved with care. Quick stops, excessive force, and uneven surfaces may cause the appliance and cart combination to overturn.



9. **Ventilation**  
Slots and openings in the cabinet are provided for ventilation and to ensure reliable operation of the video product and to protect it from overheating, and these openings must not be blocked or covered. The openings should never be blocked by placing the video product on a bed, sofa, rug, or other similar surface. This video product should never be placed near or over a radiator or heat register. This video product should not be placed in a built-in installation such as a bookcase or rack unless proper ventilation is provided or the manufacturer's instructions have been adhered to.
10. **Power Sources**  
This video product should be operated only from the type of power source indicated on the marking label. If you are not sure of the type of power supply to your home, consult your appliance dealer or local power company. For video products intended to operate from battery power or other sources, refer to the operating instructions.
11. **Grounding or Polarization**  
This video product is equipped with a polarized alternating-current line plug (a plug having one blade wider than the other). This plug will fit into the power outlet only one way. This is a safety feature. If you are unable to insert the plug fully into the outlet, try reversing the plug. If the plug should still fail to fit, contact your electrician to replace your obsolete outlet. Do not defeat the safety purpose of the polarized plug.

12. Power-Cord Protection

Power-supply cords should be routed so that they are not likely to be walked on or pinched by items placed upon or against them, paying particular attention to cords at plugs, convenience receptacles, and the point where they exit from the appliance.

13. Lightning

For added protection for this video product receiver during a lightning storm, or when it is left unattended and unused for long periods of time, unplug it from the wall outlet and disconnect the antenna or cable system. This will prevent damage to the video product due to lightning and power-line surges.

14. Power Lines

An outside antenna system should not be located in the vicinity of overhead power lines or other electric light or power circuits, or where it can fall into such power lines or circuits. When installing an outside antenna system, extreme care should be taken to keep from touching such power lines or circuits as contact with them might be fatal.

15. Overloading

Do not overload wall outlets and extension cords as this can result in a risk of fire or electric shock.

16. Object and Liquid Entry

Never push objects of any kind into this video product through openings as they may touch dangerous voltage points or short-out parts that could result in a fire or electric shock. Never spill liquid of any kind on the video product.

17. Outdoor Antenna Grounding

If an outside antenna or cable system is connected to the video product, be sure the antenna or cable system is grounded so as to provide some protection against voltage surges and built-up static charges.

Section 810 of the National Electrical Code, ANSI/NFPA No.70, provides information with regard to proper grounding of the mast and supporting structure, grounding of the lead-in wire to an antenna discharge unit, size of grounding conductors, location of antenna discharge unit, connection to grounding electrodes, and requirements for the grounding electrode.

EXAMPLE OF ANTENNA GROUNDING

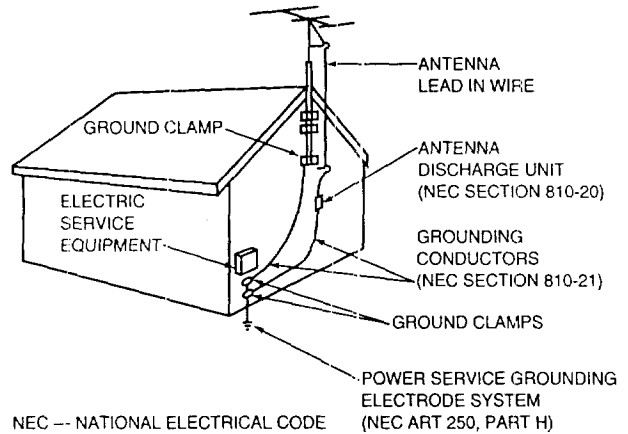

18. Servicing

Do not attempt to service this video product yourself as opening or removing covers may expose you to dangerous voltage or other hazards. Refer all servicing to qualified service personnel.

19. Damage Requiring Service

Unplug this video product from the wall outlet and refer servicing to qualified service personnel under the following conditions:

- (a) When the power-supply cord or plug is damaged.
- (b) If liquid has been spilled, or objects have fallen into the video product.
- (c) If the video product has been exposed to rain or water.
- (d) If the video product does not operate normally by following the operating instructions. Adjust only those controls that are covered by the operating instructions as an improper adjustment of other controls may result in damage and will often require extensive work by a qualified technician to restore the video product to its normal operation.
- (e) If the video product has been dropped or the cabinet has been damaged.
- (f) When the video product exhibits a distinct change in performance — this indicates a need for service.

20. Replacement Parts

When replacement parts are required, be sure the service technician has used replacement parts specified by the manufacturer or have the same characteristics as the original part. Unauthorized substitutions may result in fire, electric shock or other hazards.

## Important Safeguards

---

### 21. Safety Check

Upon completion of any service or repairs to this video product, ask the service technician to perform safety checks to determine that the video product is in safe operating condition.

### CONDENSATION

Leave the VCR on, without a tape in it, for 2 hours if the VCR has been exposed to sudden changes in temperature. Sudden temperature changes cause moisture to form on the metal parts inside the VCR. This moisture can cause the tape to stick and damage the head. Leaving the VCR on for a 2 hour period will dry the inside of the VCR.

### PROTECT THE POWER CORD

Do not damage the power cord. Damage to the power cord may cause a fire or shock hazard. When unplugging the power cord, please hold it by the plug and remove it carefully.

### DO NOT PLACE ANYTHING ON THE RECORDER

Heavy objects placed on the recorder will cause damage. The top of the recorder is also slotted to provide ventilation. Do not obstruct these ventilation slots.

### WHEN NOT IN USE

When you finish operating the recorder, always unload the cassette and turn OFF the VCR POWER.

### CARE OF THE VIDEO CASSETTE TAPES

- Avoid violent vibration or shock.
- Do not place in a location where strong magnetic fields exist (near a motor, transformer or magnet).
- Never place or store in direct sunlight.
- Avoid dusty places.
- Place the cassette in the cassette case and store vertically.
- Never store tape in a high humidity location.

### INFORMATION

This equipment has been tested and found to comply with the limits for a Class B digital device, pursuant to Part 15 of the FCC Rules. These limits are designed to provide reasonable protection against harmful interference in a residential installation. This equipment generates, uses, and can radiate radio frequency energy and, if not installed and used in accordance with the instructions, may cause harmful interference to radio communications. However, there is no guarantee that interference will not occur in a particular installation. If this equipment does cause harmful interference to radio or television reception, which can be determined by turning the equipment off and on, the user is encouraged to try to correct the interference by one or more of the following measures:

- Reorient or relocate the receiving antenna;
- Increase the separation between the equipment and receiver;
- Connect the equipment into an outlet on a circuit different from that to which the receiver is connected;
- Consult the dealer or an experienced radio/TV technician for help.

Changes or modifications not expressly approved by the party responsible for compliance could void the user's authority to operate the equipment.

If necessary, the user should consult the dealer or an experienced radio/television technician for additional suggestions. The user may find the following booklet prepared by the Federal Communications Commission helpful:

“How to Identify and Resolve Radio-TV Interference Problems.”

This booklet is available from the US Government Printing Office, Washington, D.C., 20402, Stock No. 004-000-00345-4.



Congratulations on your purchase of this Mitsubishi Video Cassette Recorder. Your new VCR produces superior sound and the highest resolution S-VHS picture available. It includes VHS Hi-Fi audio recording and playback, delivering compact disc-quality audio. Your VCR also includes the VCR Plus+ system and converter box control for simplified programming.

Your owner's guide has been designed with easy-to-follow explanations and directions. In addition, your VCR comes with Mitsubishi's exclusive ▶ViewPoint® on-screen operating system. This system has been developed to simplify the operation of your VCR with clear, understandable language and design.

Thank you for selecting our product and welcome to Mitsubishi.

## ◆ Unpacking Your VCR

As you unpack your new VCR, please make sure the following items are included:

Remote control

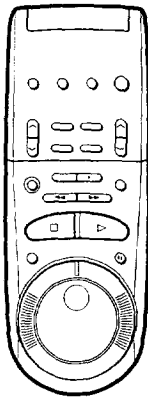

2 "AA" size batteries



1 Audio cable with red and white plugs at each end

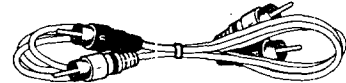

1 Video cable

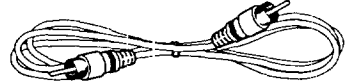

Registration card

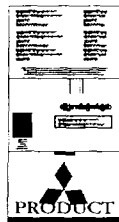

1 S-Video cable

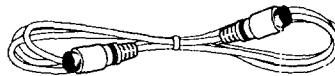

1 Coaxial cable

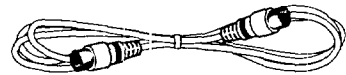

If any of these items are missing, please contact your dealer.

A few suggestions:

- 1 Be sure to save the box and packing material your VCR came in. Your VCR should always be transported in this box.
- 2 Before you hook up your VCR, please take a few minutes to:
  - complete the registration card and send it back to us immediately,
  - file your sales receipt in a safe place, and
  - place the VCR on a stable surface with sufficient lighting to do the hook-up.

▷ **Important:** Never place any heavy objects on top of the VCR. Do not place the VCR on top of the television.



Now that you have unpacked your player and read through the safety information, it's time to become familiar with the buttons and controls.

If you are experienced with using VCRs, you may just want to glance at this section and refer to it later. If VCRs are new to you, you may want to take your time and become familiar with the locations of all the controls.

On the following pages, you'll find information on:

- ◆ **Front Panel Buttons and Functions**
- ◆ **Fluorescent Display**
- ◆ **Overview of the Remote Control**
- ◆ **Rear Panel Terminals**

---

## ◆ **Front Panel Buttons and Functions**

- ① **power button and indicator (POWER)**  
Press this button to turn the VCR on or off. The indicator will light up when the power is on. You must turn the VCR off after you have programmed it to record.
- ② **converter box control transmitter**  
This window (on top of the VCR) transmits signals from your VCR to your cable box or satellite receiver.
- ③ **eject button (EJECT)**  
Press this button to eject the cassette.
- ④ **cassette slot**  
This is where you put the video cassette.
- ⑤ **stop button (STOP)**  
Press this button to stop a tape and turn off tape-related functions.
- ⑥ **jog/shuttle indicators**  
These will light up when you use special effects.
- ⑦ **play button (PLAY)**  
Press this button to play a tape.
- ⑧ **shuttle ring**  
Turn this ring to the right to fast forward a tape or to fast forward search. Turn this ring to the left to rewind a tape or to reverse search.
- ⑨ **video input 2 terminal**  
If you want to record or dub video from another source (such as a VCR or camcorder), you plug the source in here.
- ⑩ **audio input 2 terminals**  
If you want to record or dub audio from another source (such as a VCR or camcorder), you plug the source in here.
- ⑪ **input button (INPUT)**  
Press this button to select between the antenna and any other connected equipment. Also use this button to adjust the VCR's clock for daylight savings time.
- ⑫ **remote control sensor**  
This receives signals from the remote control. Do not block it.
- ⑬ **fluorescent display**  
See the next section.
- ⑭ **remote control switch (REMOTE)**  
This switch allows you to use the remote control to operate both the HS-U760 and another Mitsubishi VCR. (See page 23.)



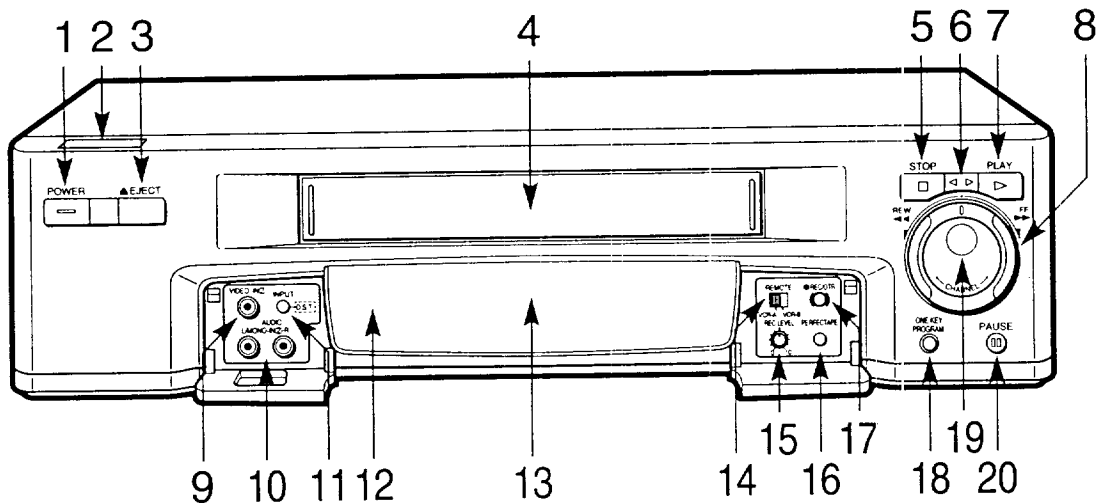

- ⑮ **record level control (REC LEVEL)**  
Use this control to lower or raise the audio level during recording.
- ⑯ **PerfectTape button (PERFECTAPE)**  
Press this button to use the PerfectTape™ feature. The PerfectTape™ feature will test your videotape and set the VCR to make the best possible recording with that tape.
- ⑰ **record button (REC/OTR)**  
Press this button once to record until the end of the tape. Press repeatedly to set the time for One-Touch Recording (OTR).
- ⑱ **jog dial**  
When the tape is stopped, this dial will change channels. When the tape is paused, it will advance the tape frame-by-frame. This dial can also adjust tracking and picture vibration. (See page 54.)
- ⑲ **pause button and indicator (PAUSE)**  
Press this button to pause a tape when recording, or to freeze a frame when viewing a tape. The indicator (II) will light up when you pause or freeze a tape.
- ⑲ **one key program button (ONE KEY PROGRAM)**  
Press to program the VCR to record.

### ◆ Fluorescent Display

(see the illustration on the next page)

- ① **lock light (LOCK)**  
This lights up when you use the “Child Lock” feature.
  - ② **remain light (REM)**  
When this is lit, the numbers in the display show the time remaining on the tape, in hours and minutes.
  - ③ **counter/time display**  
This area displays: the current time; a time counter showing how long the tape has run; the amount of time remaining on the tape; the audio level in decibels for both the left (L) and right (R) audio channels; or the channel number if the VCR is connected to a satellite receiver.
  - ④ **tape status symbol**  
This will light up when a tape is in the VCR. The dashes in the center of the symbol simulate the movement of the tape when playing and recording.
- The current time is displayed when the VCR is turned off or when you press the DISPLAY button. The counter is automatically set to “0h00m00s” when a new tape is loaded. The counter will display “- H - - M - - S” when no tape is in the VCR.

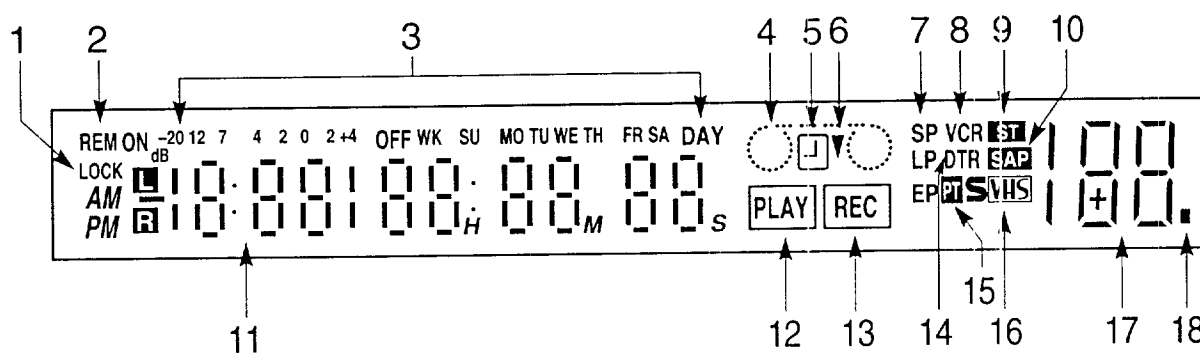

- ⑤ **programmed recording light**  
This lights up when the VCR is off and you have programmed the VCR to record.
- ⑥ **index light**  
This will flash when you are writing or erasing an index mark; it will light up when you begin searching for an index mark.
- ⑦ **tape speed lights (SP, LP, EP)**  
This will light to indicate the tape speed you are using when playing or recording. "SP" indicates standard play; "LP" indicates long play; "EP" indicates extended play.
- ⑧ **VCR light (VCR)**  
This will light up when the VCR/TV button is set to "VCR." It indicates that the antenna signal is being routed through the VCR's tuner.
- ⑨ **stereo indicator (ST)**  
This lights up when the VCR is receiving a stereo signal.
- ⑩ **SAP indicator (SAP)**  
This will light up to indicate that the channel you are watching has a Separate Audio Program, or S.A.P. An S.A.P. is an alternative soundtrack to the program you are watching. The S.A.P. is often another language.
- ⑪ **satellite channel display**  
If you set up your VCR to receive signals from a satellite receiver, this area can display the satellite channel you are receiving. This area can display 3-digit numbers up to "999."
- ⑫ **play light (PLAY)**  
This lights up when the VCR is playing a tape.
- ⑬ **record light (REC)**  
This lights up when the VCR is recording.
- ⑭ **digital tracking light (DTR)**  
This will flash when you first play a new cassette, indicating that the VCR is adjusting the tracking. When tracking is finished, it will glow steadily. If you adjust the tracking manually, it will turn off.
- ⑮ **PerfectTape (PT)**  
This will flash when the PerfectTape™ test is in progress. It will light steadily when the test is completed.
- ⑯ **S-VHS indicator**  
This will light up when you play or record in the S-VHS format.
- ⑰ **channel display**  
This displays the cable channel, broadcast channel, or input you have selected.
- ⑱ **cable tuning light**  
This lights up when your VCR is set to receive cable broadcasts.

## ◆ Overview of the Remote Control

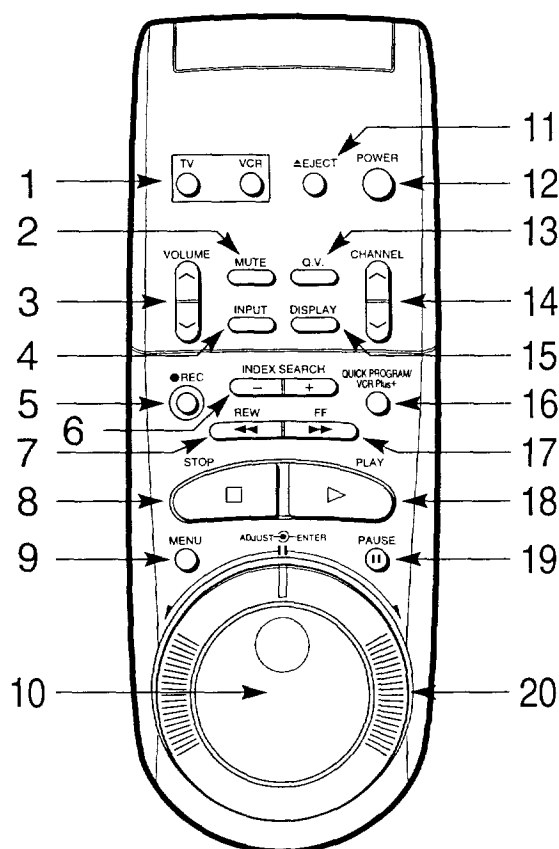

### ① **TV and VCR buttons (TV, VCR)**

In addition to operating your VCR, your VCR remote control can be used to operate most of the functions of many brands of televisions. Press the VCR button to use the remote to operate the VCR. After setting up your remote for your particular brand of television, press the TV button to use the remote to operate your television. See your TV owner's guide for more information about operating your TV.

### ② **mute button (MUTE)**

Press this button to turn off the sound completely or to restore it to its previous volume.

### ③ **volume controls (VOLUME)**

Press the bottom half of this button (indicated by the down arrow) to lower the volume; press the top half (indicated by the up arrow) to raise the volume.

### ④ **input button (INPUT)**

Press this button to select between the antenna and any other video equipment that may be connected.

### ⑤ **record button (REC)**

Press this button to start recording. When recording or playing a tape, you can use the button to add a manual index mark.

### ⑥ **index search buttons (INDEX SEARCH)**

Use these buttons to begin index search.

### ⑦ **rewind and reverse search button (REW)**

Press this button to rewind a tape or to reverse search.

### ⑧ **stop button (STOP)**

Press this button to stop a tape.

### ⑨ **menu button (MENU)**

Press this button to display the menus, which are lists of features and instructions, on your television screen. Also press the button to exit the menus.

### ⑩ **adjust dial (ADJUST)**

When the tape is paused, this dial will advance the tape frame-by-frame. When using the menus, this dial will select and adjust menu items.

### ⑪ **eject button (EJECT)**

Press this button to eject a tape.

### ⑫ **power button (POWER)**

Press this button to turn the VCR on or off. If you have programmed the VCR to record, you need to turn the VCR off.

### ⑬ **quick view button (Q.V.)**

Press this button to use quick search, to use the VCR's super quick view feature, or to use a Mitsubishi TV's quick view feature.

### ⑭ **channel buttons (CHANNEL)**

Press these buttons to change channels.

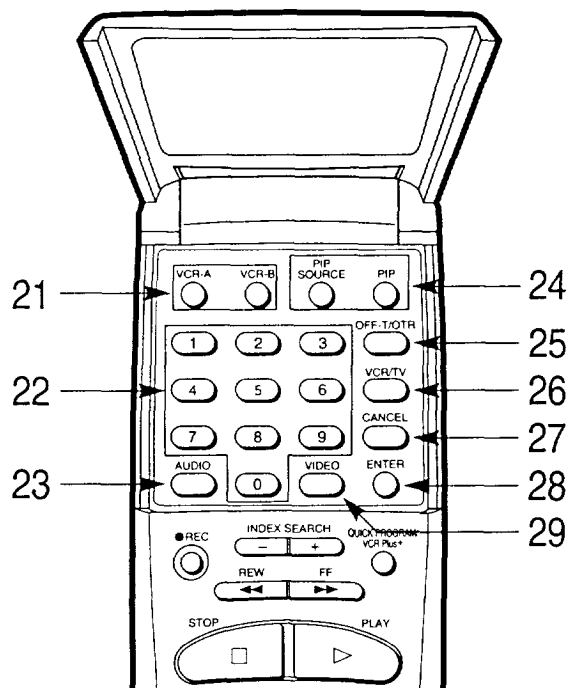

- ⑮ **display button (DISPLAY)**  
Press this button to display the following information on the television:
- how much time has elapsed on the current tape,
  - the channel number you are watching,
  - the source that is supplying the VCR with a signal,
  - the present time,
  - whether the VCR is stopped, playing, or recording, and
  - how much time is left on the tape.
- This button can also be used to turn on and off the “Child Lock” feature.
- ⑯ **quick program and VCR Plus+ button (QUICK PROGRAM/VCR Plus+)**  
This button allows you to program your VCR more quickly and easily. When you press this button, you will immediately see the “Program to record” screen, where you can enter a VCR PlusCode number or begin programming your VCR to record.
- ⑰ **fast forward and fast forward search button (FF)**  
Press this button to fast forward a tape or to fast forward search.
- ⑱ **play button (PLAY)**  
Press this button to play a tape.

- ⑲ **pause button (PAUSE)**  
Press this button to pause a tape when recording or to freeze a frame when viewing a tape.
- ⑳ **shuttle ring**  
When a tape is playing, turn this ring to adjust the playback speed. When using the menus, turn this ring to enter or cancel selections. When viewing TV channels through the VCR, use this ring to add channels to, or delete channels from, the super quick view memory.
- ㉑ **mode buttons (VCR-A, VCR-B)**  
Use these buttons to operate two Mitsubishi VCRs with one remote. (See page 23.)
- ㉒ **number buttons**  
Use these buttons to select TV stations and to enter VCR PlusCode numbers.
- ㉓ **audio function button (AUDIO)**  
Press this button to adjust the VCR’s audio functions.
- ㉔ **picture-in-picture buttons (PIP SOURCE, PIP)**  
Use these buttons to control the picture-in-picture functions of a Mitsubishi TV.
- ㉕ **off-timer and one-touch recording button (OFF-T/OTR)**  
This button has two functions:
- If the remote is set up to operate a Mitsubishi TV, use this button to use the TV’s off-timer. (See your Mitsubishi TV owner’s guide for more details.)
  - It can be used to operate the VCR’s OTR feature (see page 46).
- ㉖ **VCR/TV button (VCR/TV)**  
Press this button to switch between the VCR’s tuner and the TV’s tuner. When you select “VCR,” you change channels on the VCR; when you select “TV,” you change channels on the TV.
- ㉗ **cancel button (CANCEL)**  
Use this button to cancel selections on the on-screen menus, to delete channels from the super quick view memory, or to reset the counter display to “000000s.”

- ⑳ **enter button (ENTER)**  
Use this button to add channels to the super quick view memory or to enter selections on the on-screen menus.

- ㉑ **video function button (VIDEO)**  
Press this button to adjust the VCR's video functions.

## ◆ Rear Panel Terminals

### ① antenna terminals

#### • antenna in (ANTENNA IN)

Use this terminal to attach an external antenna or cable. This “brings in” an outside signal.

#### • antenna out (ANTENNA OUT)

Use this terminal to attach the VCR to your TV. This terminal “sends out” the signal to your TV.

### ② video input and output terminals

These yellow terminals are for sending (OUT) and receiving (IN) video signals. You will only need to use these if you have a monitor television, or for making copies of tapes. The black terminals marked with an “S” marked are called “S-Video” terminals and can be used to connect televisions with S-Video terminals. (“S-Video Terminal” refers to a Separate Luminance-Chrominance (Y/C) terminal that conforms to the NTSC signal.)

### ③ converter box control terminal (CONVERTER BOX CONTROL)

Use this terminal to connect a cable that sends signals to a converter box or satellite receiver. (The cable is available from your Mitsubishi dealer, part name, “KIT-CBC.”)

Use this cable if:

- your converter box or satellite receiver cannot receive a signal from the Converter Box Control Transmitter, or
- you would like to place your converter box or satellite receiver away from the VCR.

### ④ edit terminal (EDIT)

When you use the edit terminal to connect two Mitsubishi VCRs, you can synchronize the VCRs' pause and record functions, making it easier to edit copies of tapes.

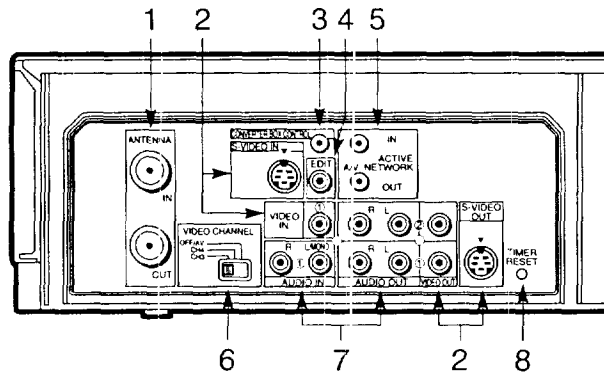

### ⑤ A/V Network terminals (ACTIVE A/V NETWORK)

Use these terminals to connect the VCR to other Mitsubishi products that have Active A/V Network terminals or A/V Network terminals.

### ⑥ video channel switch (VIDEO CHANNEL)

If you connect your VCR to a monitor TV, set this switch to “OFF/AV.” If you connect your VCR to a regular TV, set the switch to “3” or “4,” whichever station is NOT used for broadcasting in your area. (See page 21.)

### ⑦ audio input and output terminals

These red and white terminals are for sending (OUT) and receiving (IN) audio signals. Red signifies the right channel, and white signifies the left channel. Stereo audio cables are also color coded red and white. If you are receiving or sending a mono (non-stereo) signal, you should use only the left (white) terminal.

### ⑧ timer reset button (TIMER RESET)

If you press this button, you will erase all of your programmed recording settings, reset the on-screen language, and also reset the clock. Use this button with care.



Now that you're familiar with some of your VCR's features, you're ready to connect the antenna and the television. You won't have to complete all of the connections you see in this chapter — make only those connections that apply to your equipment.

You should keep in mind that there are two steps you need to take to connect your VCR: first, connect the antenna or cable to the VCR, then connect the VCR to the television.

- ◆ **Connecting the Antenna or Cable to the VCR**
- ◆ **Connecting the Television**
- ◆ **Connecting a Satellite Receiver (optional)**
- ◆ **Connecting the A/V Network (optional)**

---

## ◆ Connecting the Antenna or Cable to the VCR

The first thing you need to do is connect the antenna or cable. Because there are at least three different types of antennas, this chapter will show how to connect all of them. You don't need to make all the connections. First, find out what kind of antenna you have. Then, make the connection for that type of antenna. You can then go to the next section, "Connecting the Television."

This section shows you:

- Connecting cable antennas,
- Connecting other antennas, and
- Connecting separate UHF/VHF antennas.

### Connecting cable antennas

If you have cable TV, this is the only antenna you need to hook up. Because some cable companies require a cable box (for unscrambling cable signals), there are two kinds of cable connections shown: with and without a cable box.

#### connecting cable without a cable box

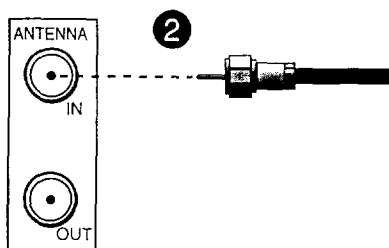

- ❶ Find the "source" cable. It usually comes out of the floor or out of a wall. If it is connected to your TV, disconnect it.
- ❷ Connect the cable to the ANTENNA IN terminal on the back of your VCR. Screw or push the cable onto the terminal until it is tight.
- ❸ When you are finished, go to page 15, "Connecting the Television."

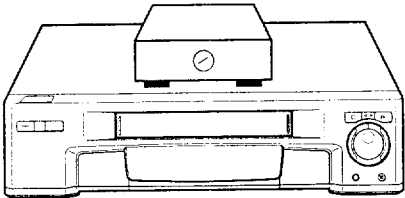
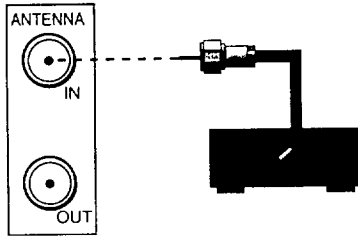

### connecting cable with a cable box

If your cable system requires you to use a cable box, follow the directions below to connect your cable box to your VCR:

- ❶ Disconnect the cable box from the TV.
- ❷ Connect the cable coming from the cable box to the ANTENNA IN terminal on the back of your VCR. Screw or push the cable onto the terminal until it is tight.
- ❸ Place the cable box on the center of the top of the VCR. Place the rear of the cable box flush with the rear of the VCR. Make sure the cable box doesn't obstruct the VCR's ventilation slots.
- ❹ When finished, go to page 15, "Connecting the Television."

If your cable box has audio and video outputs, follow the additional directions below.

- ❺ Connect one audio cable to the left audio output terminal on the cable box. Connect the other end of this cable to the AUDIO INPUT terminal on the VCR labeled L/MONO.
- ❻ Connect one audio cable to the right audio output terminal on the cable box. Connect the other end of this cable to the AUDIO INPUT terminal on the VCR labeled R.
- ❼ Connect one video cable to the video output terminal on the cable box. Connect the other end of this cable to the VIDEO INPUT terminal on the VCR.

If you plan to connect a satellite receiver to your VCR, connect the cable box to the input terminals on the front of the VCR. Otherwise, connect the cable box to the rear terminals. Audio and video cables are available at your local electronics store.

▷ **Important:** If you need a cable box to descramble all cable channels, you can't record one channel while watching another. If you have questions concerning your cable system, please contact your cable company.

### Connecting other antennas

If you don't have cable TV, you'll need to connect a regular antenna. Your antenna may have one of two different kind of ends (called "leads") on it. The two kinds of leads are:

300-ohm flat twin leads  
that look like this... :



...or a 75-ohm round lead  
that looks like this:



Follow the procedures for connecting the kind of leads your antenna has, then go to page 15, "Connecting the Television."

**connecting an antenna with a 300-ohm flat twin lead**

(If you have a 300-ohm flat twin lead, you will need to purchase a 300-75 ohm adapter at your local hardware or electronics store.)

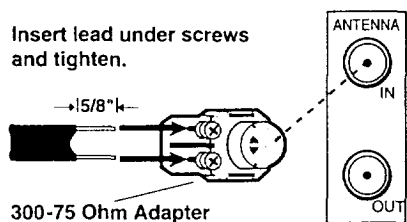

- 1 Disconnect the antenna from the back of the TV.
- 2 Before you can attach the antenna leads to the adapter, you need to expose a 5/8 inch segment of each lead by scraping off the brown plastic covering. Sometimes these leads have "U" shaped clips that fit around the plastic, in which case you will not need to peel back the plastic.

Wrap each exposed end of wire once or twice around the screw shanks of the adapter (or insert the clips under the screw heads). Tighten the screws.

- 3 Push the adapter firmly onto the antenna terminal on the VCR labeled ANTENNA IN.
- 4 Go to page 15, "Connecting the Television."



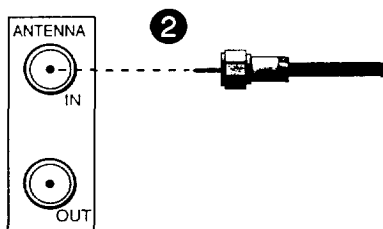



**connecting an antenna with a 75-ohm round lead**



- 1 Disconnect the antenna from the back of the TV.
- 2 Connect the antenna to the ANTENNA IN terminal on the back of the VCR. Screw or push the cable until it is tight.
- 3 Go to page 15, "Connecting the Television."

**Connecting separate UHF/VHF antennas**

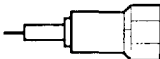
You may have two separate antennas (one UHF, one VHF) that bring TV signals into your home. If you do, you'll need to combine the two antennas before connecting them to the VCR. To do this, you'll need an attachment called a combiner (which is available at your electronics store). This chart will help you determine the kind of combiner you need.

If your UHF antenna wire looks like this...	...and your VHF antenna wire looks like this...	...then you need a combiner like this.
		
		



To connect your antennas:

- ❶ Disconnect the antennas from the back of the TV.
- ❷ Connect the antenna leads onto the combiner.
- ❸ Screw or push the combiner onto the ANTENNA IN terminal on the VCR.
- ❹ See “Connecting the Television,” below.

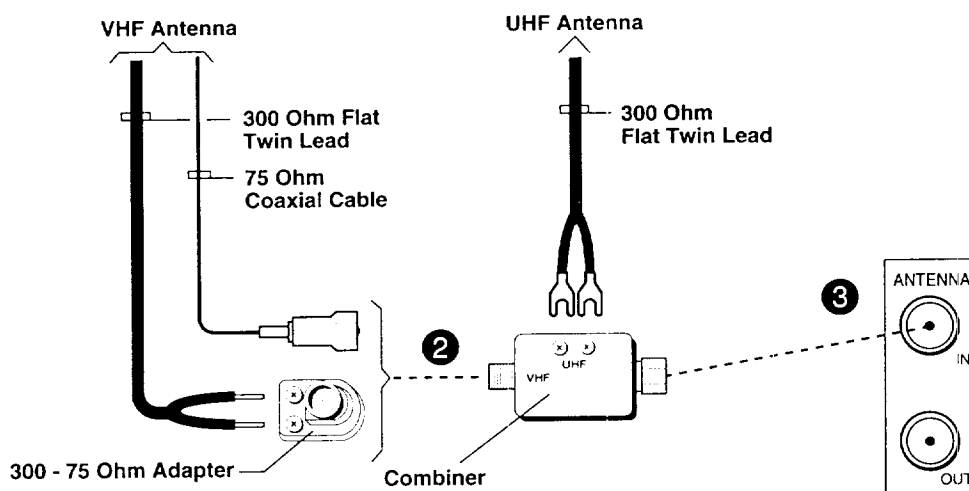

## ◆ Connecting the Television

Now that you have completed the antenna connections to your VCR, you're ready to connect the VCR to the TV. (If you haven't connected the antenna to the VCR, go to page 12, "Connecting the Antenna or Cable to the VCR.") Because every television is different (especially older model TVs), your VCR may need to be connected in one of a variety of ways. This section shows you:

- Determining if you need a splitter,
- Connecting a regular TV to the VCR, and
- Connecting a TV with audio and video inputs.

### Determining if you need a splitter

You should look at the back panel of your TV to see if you need any special equipment to connect the TV to the VCR. You may need an attachment called a UHF/VHF splitter (which is available at your local electronics store).

The chart on the next page will tell you if you need a splitter, and what the splitter will look like.

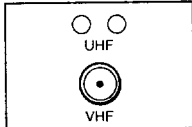
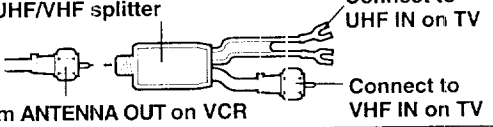
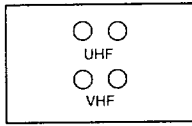
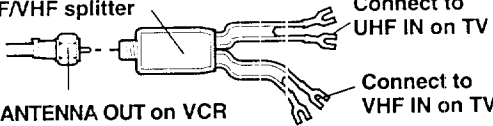
If the TV's antenna terminal looks like this...	...then you will need a splitter that looks like this.
	<p>No splitter needed</p>
	
	

**Connecting a regular TV to the VCR**

- 1 Take the black cable (called a coaxial cable) that is supplied with your VCR and attach it to the terminal labeled ANTENNA OUT on the back of your VCR.
- 2 Connect the other end of this cable to the terminal on your TV labeled ANTENNA IN. This terminal is sometimes also called "ANT-IN" or "VHF IN." If you have an older TV without this kind of terminal, you will have to use a splitter and then connect the splitter to the television.
- 3 If you have a TV with audio and video inputs, you should proceed to the next section, "Connecting a TV with audio and video inputs." Otherwise, your connections are complete.

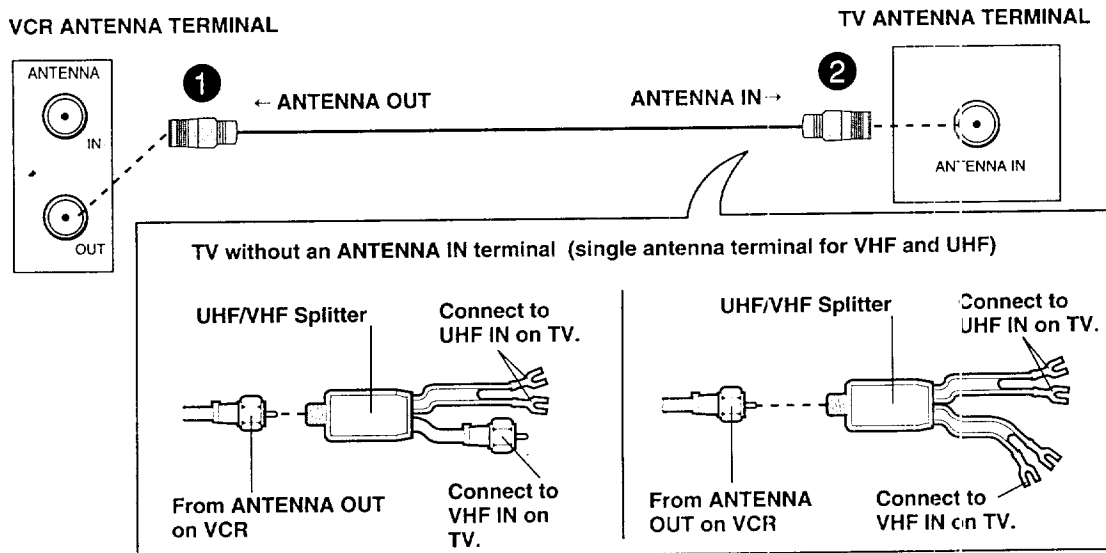

## Connecting a TV with audio and video inputs

Because you purchased a Hi-Fi VCR, you will want to take advantage of its superior sound capability and connect it to a stereo TV system with audio and video inputs.

Before you begin this section:

- You should have already completed the section “Connecting a regular TV to the VCR.”

### connecting a stereo TV with audio and video inputs

- 1 Connect a set of red and white audio cables to the AUDIO OUTPUT terminals on the VCR labeled AUDIO OUT. The red cable is for connecting the right (R) channel and the white cable is for connecting the left (L) channel. If your TV has only one (mono) audio input, connect only the white (L) output from your VCR.

▷ **Important:** If you are connecting your VCR to a mono (non-stereo) TV, you cannot take advantage of your VCR’s Hi-Fi sound.

- 2 Connect the other ends of this cable to the AUDIO INPUT terminals on your TV labeled AUDIO IN.
- 3 Connect a single yellow video cable to the VIDEO OUTPUT terminal labeled VIDEO OUT on the VCR, **or** connect a single S-Video cable to the S-VIDEO OUT terminal on the VCR.
- 4 Connect the other end of the video cable to the yellow VIDEO INPUT terminal on the TV labeled VIDEO IN, **or** connect the other end of the S-Video cable to the S-VIDEO IN terminal on the TV.

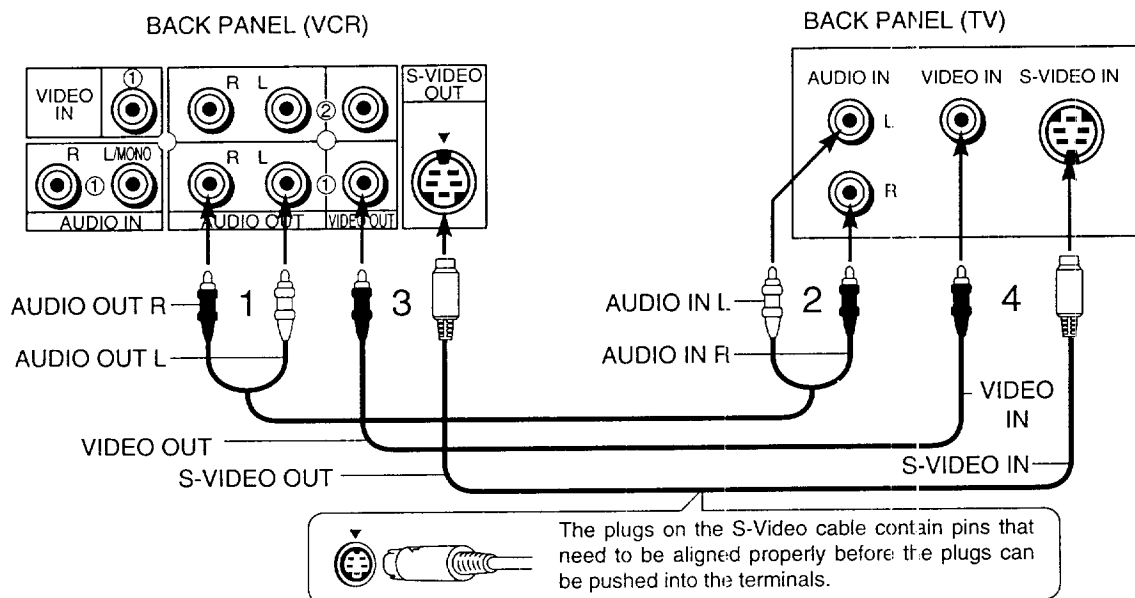

◆ Connecting a Satellite Receiver (optional)

If you have an RCA Satellite Receiver, you can connect the receiver to your VCR. This will not only allow you to record TV programs coming from the receiver, but it will allow you to control the receiver through the VCR.

connecting a satellite receiver

To connect the satellite receiver, you will need an S-Video cable and one stereo audio cable. You can purchase these cables at your Mitsubishi dealer or at your local electronics store.

before you begin, you should:

- have completed all connections between your VCR, TV, and cable or antenna; (see pages 12-17) and
  - make sure that your satellite receiver has been installed correctly. (See your satellite receiver's manual for more information.)
- ❶ Place the satellite receiver near your VCR so that there is an open path between the remote control sensor on the receiver and the Converter Box Transmitter on the VCR. (The Converter Box Transmitter is the small window on top of the VCR.)
  - ❷ Connect one audio cable to the left audio output terminal on the receiver; connect the other end of the cable to the terminal on the rear panel of the VCR labeled AUDIO IN 1 L/MONO. Connect another audio cable to the right output terminal on the receiver; connect the other end of this cable to the terminal on the rear panel of the VCR labeled AUDIO IN 1 R.

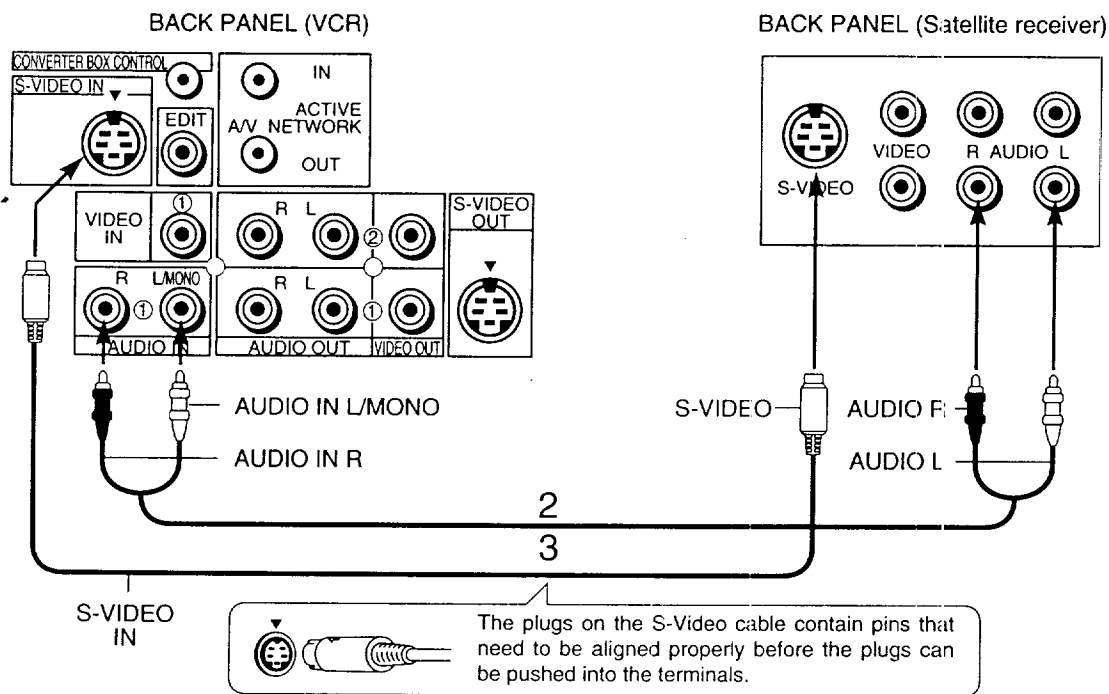

- ③ Connect an S-Video cable to the S-Video output terminal on the receiver; connect the other end of the cable to the terminal on the rear of the VCR labeled S-VIDEO IN.

▷**Important:** If possible, you should have connected your VCR to your TV with an S-Video cable. Not only will this provide you with a better picture, but it will allow you to watch the satellite video signal on your TV even when the VCR is off. If you connect your VCR to your TV with a standard video cable, you will have to turn your VCR on to watch the video signal from the satellite receiver. (You will be able to hear the audio signal from your satellite receiver both when the VCR is on and when it is off.)

If you want to connect a cable box with audio/video outputs to your VCR, connect it to the terminals on the front of the VCR.

When you connect a satellite receiver to the S-Video input on the rear of the VCR, you cannot record through the standard video input on the rear of the VCR.

#### ◆ Connecting the A/V Network (optional)

Some Mitsubishi TVs and VCRs have special input and output terminals called the “A/V Network.” The primary purpose of the A/V Network is to “pass” remote control codes between Mitsubishi components. That is, when the A/V Network is connected, you can point your VCR remote control at the TV, and the TV will “pass” the commands on to the VCR.

To connect the A/V Network, you will need a cable with a “mini” jack at both ends. (A mini jack is the kind you find on headphones for personal stereos.) A cable may be included with your Mitsubishi TV. If not, you can purchase a cable with mini jacks at your Mitsubishi dealer or an electronics store.

To connect the A/V Network:

- ① Connect a cable to the terminal on the TV labeled A/V NETWORK OUT or ACTIVE A/V NETWORK. Connect the other end of the cable to the terminal on the VCR labeled ACTIVE A/V NETWORK IN.

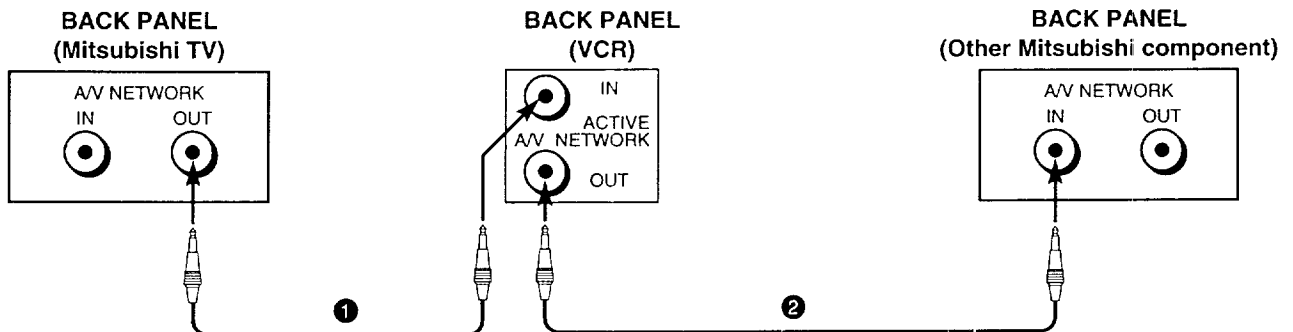

- 2 If you have another Mitsubishi component equipped with A/V Network, attach a cable to the terminal on the VCR labeled ACTIVE A/V NETWORK OUT. Attach the other end of this cable to the terminal on the other component labeled A/V NETWORK IN or ACTIVE A/V NETWORK IN.

▷ **Important:** Never connect your A/V Network in a loop, as shown below.

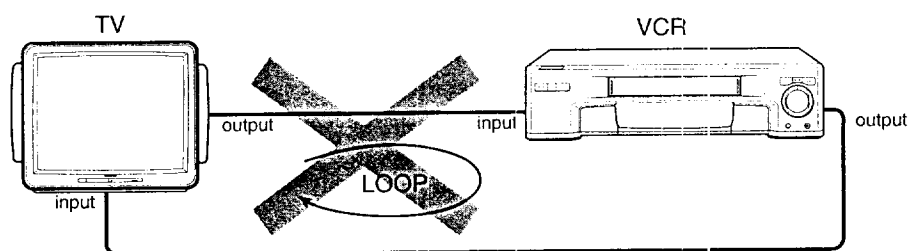

#### connecting *Active A/V Network*

Your VCR has the ability to perform certain automated functions in conjunction with Mitsubishi TVs that have ACTIVE A/V NETWORK terminals. These automated functions are called "Active A/V Network."

In order for Active A/V Network to function properly, you must make the connections above and your VCR must be connected to the EXT-1 input terminals of your Mitsubishi TV. Information on how to use the Active A/V Network features begins on page 64.



Now that you've completed your antenna, VCR, and TV connections, you're ready to start enjoying your equipment. To get the most satisfaction out of your VCR, you should carefully read the two sections, "Setting Up Your VCR for the First Time" and "Viewing the Picture Coming from Your VCR." Then you can start exploring what your new VCR can do.

In this chapter, you'll learn:

- ◆ Setting Up Your VCR for the First Time
- ◆ Using the Remote Control
- ◆ Viewing the Picture Coming from Your VCR
- ◆ Loading and Unloading Tapes
- ◆ Playing a Tape
- ◆ Selecting the On-screen Language
- ◆ Using the Audio and Video Functions
- ◆ Using the Menus to Set the Time
- ◆ Programming the VCR to Receive TV Channels
- ◆ Setting the VCR Plus+ Guide Channel Numbers
- ◆ Recording

## ◆ Setting Up Your VCR for the First Time

It's important that your VCR is set up correctly before you try to use it. If you carefully read this section, you will avoid confusion later and get the most out of operating your system.

This section teaches you about:

- Setting up your VCR if you are using a regular TV, and
- Setting up your VCR if you are using a monitor TV.

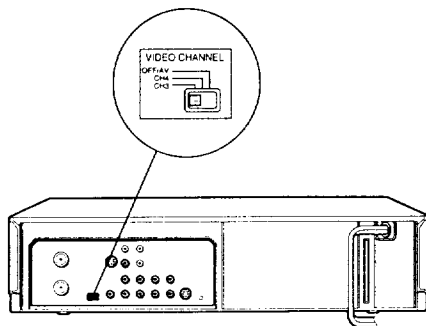

### Setting up your VCR if you are using a regular TV

- 1 Turn on your TV and tune it to channel 3 or 4, whichever is NOT used for broadcast in your area.
- 2 Look at the back panel of the VCR and set the VIDEO CHANNEL switch to channel 3 or 4 (the same channel to which you tuned the TV in step 1).
- 3 Turn the VCR on by pressing the POWER button.

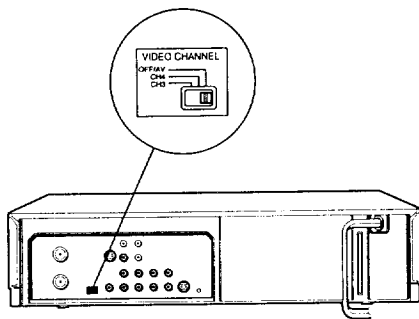

### Setting up your VCR if you are using a monitor TV

- ❶ Turn on your TV and switch it to the correct external input. (For most Mitsubishi TVs, this means pressing the TV's INPUT button until you see the words "Ext-1" on the screen.)
- ❷ Look at the back panel of the VCR and set the VIDEO CHANNEL switch to OFF/AV.
- ❸ Turn the VCR on by pressing the POWER button.

### Helpful Information

#### What is a Monitor TV?

A monitor TV is one that has both audio and video inputs. This enables the TV to display the picture and play the sound from an external tuner, such as a VCR tuner.

If your TV does not have both audio and video inputs, it is a "regular" TV.

Once you know what type of TV you are using, you might want to mark it here so that you (and others) won't forget.

Monitor

"Regular"

### ◆ Using the Remote Control

In this section, you'll learn how to set up and use your remote control. This section includes:

- Using the remote control to operate the VCR, and
- Using the remote control to operate the TV.

#### Using the remote control to operate the VCR

##### installing the batteries

- ❶ Unpack two AA size batteries.
- ❷ To remove the back cover, press the ridged area gently, then push the cover in the direction of the arrow and lift.
- ❸ Load the batteries, making sure the polarities (+) and (-) are correct.

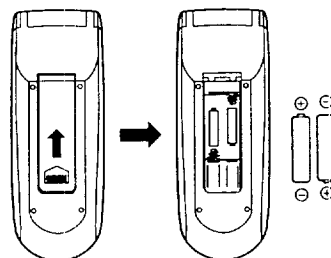

For best results, please use Duracell AA MN-1500 batteries.



### operating the remote control

- 1 Make sure the REMOTE switch on the front panel of the VCR is set to "VCR-A."
- 2 Press the VCR button on the remote control. This "tells" the remote that you want to control the VCR.
- 3 Press the VCR-A button on the remote control.
- 4 While within 23 feet of the VCR, point the remote control toward the VCR and press the buttons you desire.

### using one remote to operate two Mitsubishi VCRs

If you have another Mitsubishi VCR in addition to your HS-U760, you can use the HS-U760 remote control to operate both.

- 1 Set the REMOTE switch on the HS-U760 to "VCR-B."
- 2 Set the REMOTE switch on the other Mitsubishi VCR to "VCR-A." If the other Mitsubishi VCR has a REMOTE switch with ON/OFF settings, set it to ON. If it does not have a REMOTE switch, do not change any settings.
- 3 To operate the HS-U760, press the VCR button on the remote control, then press the VCR-B button. The remote will be set to control the HS-U760.
- 4 To operate the other VCR, press the VCR button on the remote control, then press the VCR-A button. The remote will be set to control the other VCR.

Code Buttons
1*
2*
3*
4
5
6
7
8
9
0
ENTER
CANCEL
VCR/TV
AUDIO

\*Use button 1, 2, or 3 to set up your remote for use with Mitsubishi TVs.

### Using the remote control to operate the TV

The HS-U760 remote control can operate many of the frequently-used functions of your TV. This way, you need to use only one remote to operate both your VCR and TV.

The HS-U760 remote control is pre-set to operate Mitsubishi televisions, but it can also operate TVs from other manufacturers. If you need to set your remote control for your particular brand of television, follow the instructions below.

### setting up your remote control to operate your TV

- 1 Turn off your TV.
- 2 On the HS-U760 remote control, press the TV button.
- 3 While holding in the PIP button, press one of the buttons listed in the "Code Buttons" list to the left. If your TV turns on, proceed to step 5.

- 4 If your TV does not turn on, repeat step 3, but try a different button listed in the “Code Buttons” list. Keep trying the buttons until your TV turns on.
- 5 Once your TV has turned on, your remote is set up to operate your brand of TV. You may want to circle the code button that you used.

You do not need to perform this set-up again unless you change the batteries, set up your remote for another brand of television, or you get a new TV.

Once you have correctly set your remote control to operate your TV, you will be able to use the POWER, CHANNEL, VOLUME, MUTE and number buttons to operate your TV.

Additionally, you will be able to use the DISPLAY, INPUT and ENTER buttons, depending on which type of TV you have. Please refer to the table below.

If you used this code button to set up your remote ...	... then the DISPLAY button will work like this button...	... and the INPUT button will work like this button...	... and the ENTER button will work like this button...
1	DISPLAY	INPUT	ENTER
2	—	TV/VIDEO	—
3	DISPLAY	TV/VIDEO	100
4	DISPLAY	—	ENTER
5	DISPLAY	—	ENTER
6	RECALL	TV/VIDEO	—
7	RECALL	TV/VTR	ENTER
8	DISPLAY	AUX	100
9	—	TV/VIDEO	—
0	DISPLAY	TV/VIDEO	100
ENTER	—	—	ENTER
CANCEL	DISPLAY	—	100
VCR/TV	DISPLAY	TV/VTR	ENTER
AUDIO	DISPLAY	TV/VIDEO	ENTER

- ▷ **Important:** Depending on the model TV you have, all or some of the buttons may not function, or they may operate different features than indicated above. You may need to use the TV's remote control.
- ▷ **Important:** Sometimes manufacturers will change the remote control codes for their products, or they will use more than one code. If this is the case, your remote may not be able to control your TV.
- ▷ **Important:** When you replace the batteries in your remote, the remote will return to its initial setting (code button “1”). Repeat the steps above to reset your remote control. If you enter a new code, the previous code will be erased.

#### operating your TV with the HS-U760 remote control

- 1 Press the TV button on the HS-U760 remote control.

- ② Point the remote control towards the remote sensor on the TV and press the desired buttons.
- ③ To once again control the VCR, press the VCR button.

▷ **Important:** Because of variations among models, some or all buttons may not work, or they may operate different functions than listed above, for your particular TV. If this occurs, you may need to use your TV remote control.

## ◆ Viewing the Picture Coming from Your VCR

This is the most important part of using your VCR, but often the most confusing: how do you view a picture coming from the VCR?

Before you begin, you should know:

- whether you are viewing a “Monitor TV” or a “Regular TV.” (See page 22.)

### Viewing the picture coming from your VCR if you are using a regular TV

- ① Turn on your TV and tune it to channel 3 or 4.
- ② Turn on the VCR by pressing the POWER button.
- ③ Check to see if the “VCR” light on the front panel display is lit. If it is not lit, press the VCR/TV button until it is lit.

You are viewing the picture from your VCR!

With this set-up, you will use the VCR/TV button when recording, when viewing tapes or broadcast stations through your VCR, or before using the VCR’s menus. You also use the VCR/TV button to switch back to normal TV viewing.

### Viewing the picture coming from your VCR if you are using a monitor TV

- ① Turn on your TV and switch it to the correct external input. (For most Mitsubishi TVs, this means pressing the TV’s INPUT button until you see the words “Ext-1” or “Input-1” on the screen.)
- ② Turn the VCR on by pressing the POWER button.

You are viewing the picture from your VCR!

If you wish to return to normal TV viewing, switch your TV’s input back to its previous position.

▷ **Important:** If your system includes a home theater receiver or an A/V receiver, refer to your home theater receiver’s owner’s guide.

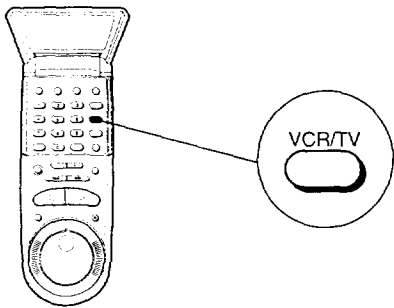

## ◆ Loading and Unloading Tapes

### Loading a tape

▶ **Important:** Tapes can be loaded into your VCR as long as the VCR is plugged in. Even when the VCR POWER is off, loading a tape will automatically turn the VCR on. Use only tapes that have a **VHS** label or an **SVHS** label.

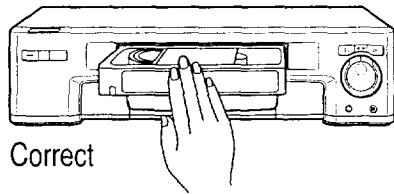

Correct

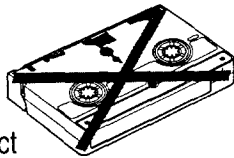

Incorrect

- 1 Hold the tape so that the long narrow edge with the contents label faces towards you. The other edge is hinged and should face towards the VCR. The plastic window that shows the videotape should face up.
- 2 Gently insert the tape into the cassette slot until the VCR automatically takes it in.

▶ **Important:** Your VCR will eject the tape if you improperly load it. If the VCR ejects the tape, remove the tape, check to see that the contents label is facing you, that the geared tape reels are facing downwards, wait a few seconds, and try again.

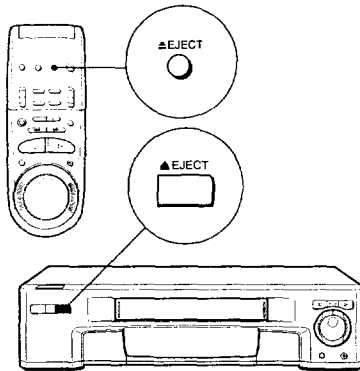

### Unloading a tape

- 1 Press the EJECT button on the front of the VCR or on the remote control. If the VCR POWER is off, the VCR will turn on, eject the tape, then turn off.
- 2 Remove the tape.

▶ **Important:** You cannot eject a tape while it is recording. You must first press STOP.

### Preventing accidental erasure

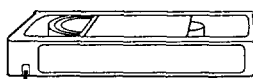

Erasure prevention tab

Tapes come with a tab that, when removed, prevents you from recording on the tape. If you attempt to record over a tape that has had this tab removed, the VCR will briefly display an error message on the TV screen and will eject the tape. To record over such a tape, simply place a piece of vinyl tape over the opening.

### Using repaired tapes

▶ **Warning:** We recommend that you take any broken or torn tapes to a professional for repair. If you repair a torn tape with improper materials, you could damage your VCR when you play the tape.

### Head cleaning

Your VCR automatically cleans the head and the drum of the VCR whenever you load a tape. If you see “noise” or snow when playing a tape, eject the tape, re-load the tape, then wait 3 or 4 seconds. Repeat this process several times to improve the picture.

## ◆ Playing a Tape

Now that your VCR is connected and properly set up, and you know how to view a picture coming from your VCR, it's time to play a tape. This section describes:

- Playing back a tape, and
- Using basic playback controls.

### Playing back a tape

Before you begin, you need to know:

- how to view the picture coming from your VCR (page 25).

- 1 To play a tape, load a pre-recorded cassette.
- 2 Press the PLAY button either on the front panel or on the remote control.

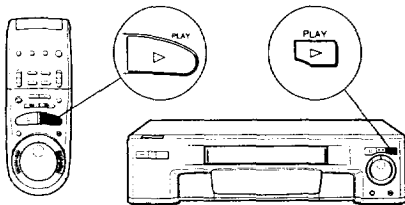

The VCR will automatically play the tape at the correct speed. When the VCR reaches the end of the tape, it will automatically rewind the tape and stop.

Playing a tape is also an Active A/V Network Feature. (For more information, please see page 64.)

### Using basic playback controls

#### rewinding a tape

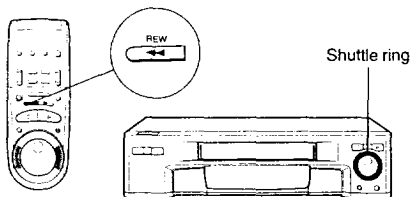

Press the REW button on the remote control or turn the shuttle ring on the front panel to the left.

If the tape is stopped, you will begin rewinding. If the tape is playing, you will begin "reverse speed search."

► **Important:** If you press the POWER button while the tape is rewinding, the VCR will turn OFF when the beginning of the tape is reached.

#### fast forwarding a tape

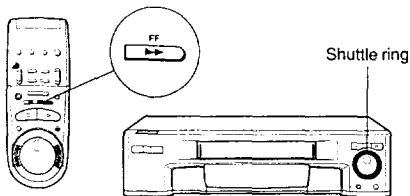

Press the FF button on the remote control or turn the shuttle ring on the front panel to the right.

If the tape is stopped, you will begin fast forwarding. If the tape is playing, you will begin "forward speed search."

#### pausing a tape

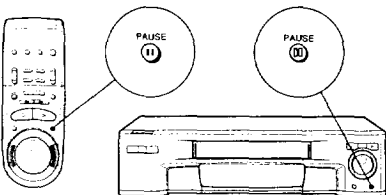

Press the PAUSE button on the front panel or on the remote control to freeze the picture on the screen.

► **Important:** If you leave the VCR in pause for 5 minutes, the VCR will automatically stop to prevent damage to the tape.

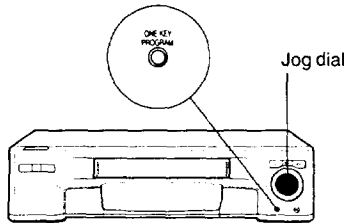

### controlling vibration during still frame

If the picture vibrates during still frame, turn the jog dial while holding down the ONE KEY PROGRAM button on the front panel until the picture is steady.

## ◆ Selecting the On-screen Language

You can set your VCR to display on-screen messages, menus, and functions in English or French. You should do this before you use the menus or set any audio/video functions.

### Before you begin, you need to know:

- how to view the picture coming from your VCR. (See page 25.)

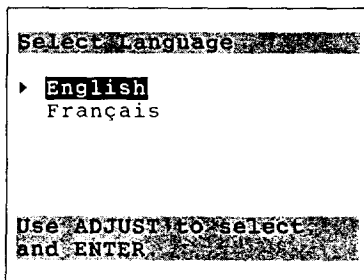

- 1 Make sure you are viewing the picture coming from your VCR. Then, press the MENU button on the remote control. If this is the first time the menus have been used, you will see the menu for selecting an on-screen language.
- 2 Turn the ADJUST dial on the remote control to move the cursor next to the desired language.
- 3 Turn the shuttle ring right on the remote control. The menu will change to the "VCR Main Menu."
- 4 Press the MENU button to exit the menus.

▷ **Important:** The "Select Language" menu is unique. While all other menus can be accessed at almost any time, the "Select Language" menu will not automatically appear again after it is first set. To see the "Select Language" menu, press the TIMER RESET button on the back of the VCR, then follow the procedure on this page.

## ◆ Using the Audio and Video Functions

You can use the remote control to select many of the VCR's audio and video functions and adjust their settings. The VCR will display the settings on the television's screen.

This section will teach you about:

- Selecting and adjusting the audio and video functions,
- Descriptions of audio functions, and
- Descriptions of video functions.

The audio functions you can adjust are:

- audio monitor,
- normal record,
- level meter, and
- front display.

The video functions you can adjust are:

- record speed,
- record format,
- tape,
- intelligent picture (I.P.), and
- sharpness.

### Selecting and adjusting the audio and video functions

Below are instructions on how to select and adjust the audio and video functions. If you are not familiar with the purpose of these functions, definitions begin below.

Before you begin, you need to know:

- how to view the picture coming from your VCR (page 25).

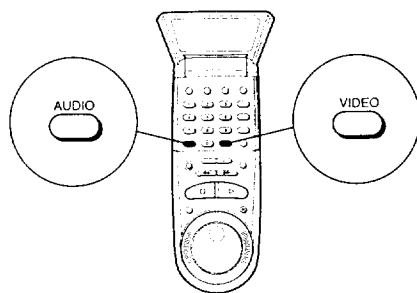

- 1 Press the AUDIO button on the remote control to see the audio function menu, or press the VIDEO button on the remote control to see the video function menu.
- 2 Press the AUDIO or VIDEO button until the function you want to adjust appears.

#### Audio function menu

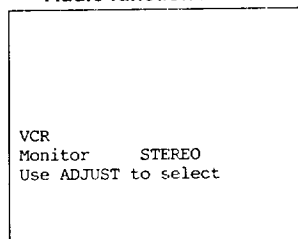

#### Video function menu

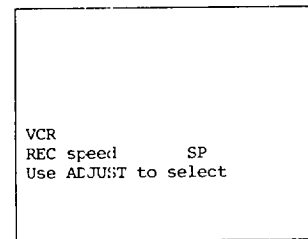

- 3 Turn the ADJUST dial on the remote to adjust the setting. The functions will disappear if you do not press any buttons for 5 seconds.

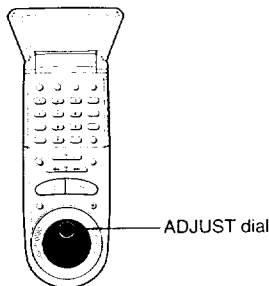

▷ **Important:** The audio and video function menus do not appear when the VCR menu is displayed; when playing a tape with I.P. set to "DUB"; or during special effects playback. The recording speed (REC speed), recording format (REC format), and tape functions do not appear during playback. The "Sharpness" video function only appears during playback when "I.P. switch" is set to normal.

### Descriptions of audio functions

Below are descriptions of the audio functions, their uses and their settings.

#### audio monitor

The monitor function allows you to listen to the various audio tracks that your VCR is capable of recording. You can choose to listen to a MONO track, both channels of the STEREO track, or either of the channels (left (L) and right (R)) of the stereo track.

- Choose L to listen to the left channel of a stereo track.
- Choose R to listen to the right channel of the stereo track.
- Choose STEREO to listen to both stereo channels.
- The MONO track is lower in quality than the others, and the monitor is automatically set to MONO if you are watching a tape that was not recorded in VHS Hi-Fi. Set the audio monitor to MONO to hear an S.A.P. signal recorded on the mono track of a Hi-Fi tape (see below).

▷ **Important:** If you have your VCR connected to a surround sound system, set the audio monitor to STEREO. Surround sound requires both left and right channels to create the rear channel effects.

#### **normal recording (Normal REC)**

When your VCR is recording, it actually records the audio portion of a program twice: once on the stereo Hi-Fi tracks, and once on the mono track. Additionally, your VCR is able to receive Separate Audio Program broadcasts, also known as an S.A.P. broadcast. An S.A.P. broadcast is an alternative audio soundtrack for a program; it is often a soundtrack in another language.

You can use the normal recording function to record the S.A.P. broadcast on the mono track by choosing "SAF." Otherwise, choose "L+R." In either case, the main program is recorded on the stereo Hi-Fi track. Also, if there is no S.A.P. broadcast, the VCR will record the main program on the mono track.

Be careful if you choose S.A.P. If you play your tapes on a non-Hi-Fi VCR, you only hear the mono track. You may have to watch your favorite show in a language you don't understand!

#### **level meters (Level meter)**

Use this function to turn the front panel level meters on or off.

#### **front display (Front disp)**

Use the front display function to dim or brighten the front panel.

### **Descriptions of video functions**

Below are descriptions of the video functions, their uses and their settings. To select these functions or to adjust their settings, refer to the section "Selecting and adjusting the audio and video functions." (See page 29.)

#### **recording speed (REC speed)**

The recording speed has an effect on picture quality. SP produces the best picture quality and records up to two hours of video on a T-120 tape. Mitsubishi's EP speed has only slightly poorer quality, and records up to six hours on a T-120. You can only record in SP or EP speed, but play back tapes recorded in SP, LP or EP.

#### **recording format (REC format)**

This function allows you to choose between recording in standard VHS or Super-VHS (S-VHS).



#### tape (Tape)

Adjust this function to ensure the accuracy of the Tape Remaining display. If you are using a tape that is two hours long or less (labeled T-30 through T-120), set this function to "T-120." If you are using a tape labeled T-160, set the function to "T-160." If you are using a tape labeled T-180, set the function to "T-180." You cannot use this function with a tape that is less than 30 minutes long, or with a tape labeled "T-210."

#### Intelligent picture (I.P. Switch)

This function is used to turn on the Intelligent Picture (I.P.) circuitry, which automatically maximizes picture quality. Set the switch to "ON" when playing an older tape, a poor quality tape, or rental tapes. Set it to "DUB" when you are using the HS-U760 to dub to another VCR.

#### sharpness (Sharpness)

Use this function to adjust between sharp (+) and soft (-) picture.

## ◆ Using the Menus to Set the Time

This section will show you how to use the on-screen menus. You will use the menus to operate many features, such as setting the time, programming to record, and memorizing channels.

#### Before you begin, you need to know:

- how to view the picture coming from your VCR (page 25),
- that you use the ADJUST dial and shuttle ring on the remote control, not on the front panel, to use the menus.

- 1 Make sure you are viewing the picture coming from your VCR. Then, press the MENU button on the remote control. You will see the "VCR Main Menu." Make sure the cursor is next to the words "First Time Set-Up." If it is not, use the ADJUST dial to place the cursor there.
- 2 Turn the shuttle ring right. The "First Time Set-Up" menu will appear. The cursor will be next to "Set the clock." Turn the shuttle ring right.
- 3 You will see the "Set the clock" menu. The cursor will be next to the word "Month." Turn the ADJUST dial until the correct month appears on screen. Turn the shuttle ring right.
- 4 The cursor automatically moves to the word "Year." Turn the ADJUST dial to set the year. Turn the shuttle ring right.

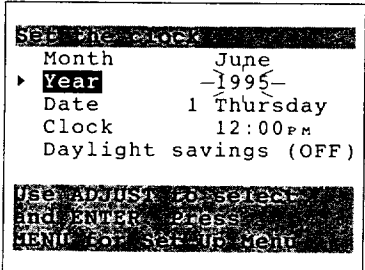
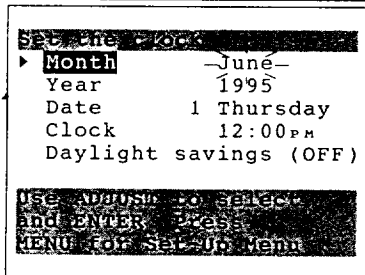
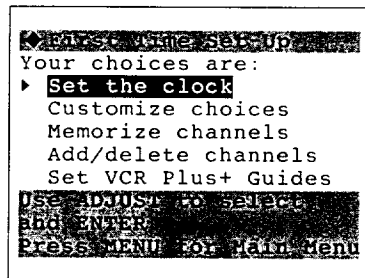

```

Set the clock
Month      June
Year      1995
▶ Date    -18 Sunday-
Clock     12:00 P.M.
Daylight savings (OFF)

Use ADJUST to select
and ENTER. Press
MENU for Set-Up Menu

```

```

Set the clock
Month      June
Year      1995
Date      18 Sunday
▶ Clock    7:00 P.M.
Daylight savings (OFF)

Use ADJUST to select
and ENTER. Press
MENU for Set-Up Menu

```

```

Set the clock
Month      June
Year      1995
Date      18 Sunday
▶ Clock    7:30 P.M.
Daylight savings (OFF)

Use ADJUST to select
and ENTER. Press
MENU for Set-Up Menu

```

```

Set the clock
Month      June
Year      1995
Date      18 Sunday
Clock     7:30 P.M.
▶ Daylight savings (OFF)

Use ADJUST to select
and ENTER. Press
MENU for Set-Up Menu

```

- 5 The cursor automatically moves to the word "Date." Turn the ADJUST dial to set the date. Turn the shuttle ring right.

- 6 The cursor automatically moves to the word "Clock." The hour numbers and the am/pm indicator will be blinking. Turn the ADJUST dial to set the hour and am/pm at the same time. Turning the dial right moves the clock forward; turning the dial left moves the clock backwards.

Turn the shuttle ring right.

- 7 The minutes numbers will now be blinking. Turn the ADJUST dial to set the minutes. When you have set the correct time, turn the shuttle ring right.
- 8 The cursor automatically moves to the words "Daylight savings." If you are currently following Daylight Savings Time, use the ADJUST dial to select "ON"; otherwise, use the ADJUST dial to select "OFF." Turn the shuttle ring right; the display will return to the "First Time Set-Up" menu and the clock will start running.
- 9 Press the MENU button once to return to the "VCR Main Menu"; press the MENU button again to turn off the menus.

#### setting the clock forward or backward by one hour (adjusting for Daylight Savings Time)

You can adjust the Daylight Savings Time setting without entering the menus. With the VCR turned off, press the INPUT button on the front panel. If Daylight Savings is currently ON, this will turn it off and set the clock back one hour. If it is currently OFF, this will turn it on and set the clock forward one hour. Each time you press the INPUT button, the Daylight Savings setting will switch between "ON" and "OFF." Any time you adjust this setting, check your programmed recordings to be sure they are set to the correct time.

If you want to adjust the clock when your VCR is in stand-by for programmed recording, simply press the POWER button *on the front panel*. This turns off the programmed recording light, but the VCR will remain turned off. When you finish adjusting the clock, press the POWER button again, and make sure that the programmed recording light is back on.

- ▷ **Important:** If you have a Mitsubishi TV with both Active A/V Network and "StarSight" features, you don't have to set the time on your VCR. See your TV Owner's Guide for details.

## ◆ Programming the VCR to Receive TV Channels

Before your VCR can receive television channels, you need to program all of the channels you can receive into your VCR. Fortunately, our menu system makes this an easy process. This section will also explain some other channel-related functions.

This section explains:

- Programming channels automatically,
- Using video mute,
- Adding and deleting channels, and
- Selecting a channel.

### Programming channels automatically

Using this process, your VCR will automatically tune in all of the television stations you can receive. You can later get rid of unwanted or unused stations.

#### A special note to cable box subscribers

*If your local cable box company scrambles some or all stations, and/or requires you to use a cable box, then your ability to program channels will be limited. The cable box receives all of your channels and then sends only one to your TV (and your VCR), usually on channel 3 or 4.*

*If you are required to use a cable box, you should choose “Cable box only” option in step 5 on the next page. Your HS-U760 will use its special Converter Box Control technology to change the channels on the cable box.*

*If your cable box or cable system seems incompatible with your new VCR, call your cable company. They may be able to provide solutions to your problems.*

Before you begin, you should:

- have completed all connections between your VCR, TV, cable, antenna, cable box, and satellite receiver (if any); (pages 12-20)
- know how to view the picture coming from your VCR; (page 25)
- know how to use the menus. (See page 31.)

To program channels automatically:

- 1 Press the MENU button on the remote control. You will see the “VCR Main Menu” on the TV screen.
- 2 Use the ADJUST dial on the remote to move the cursor next to “First Time Set-Up.” Turn the shuttle ring right.
- 3 The “First Time Set-Up” menu appears on your screen. Turn the ADJUST dial to move the cursor next to “Memorize channels.” Turn the shuttle ring right.

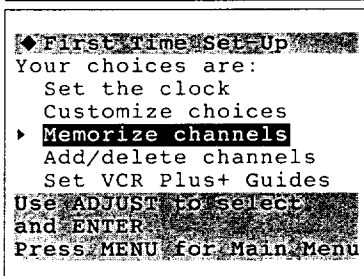
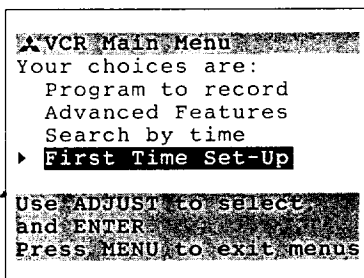

▷ **Important:** If you are recording or playing back a tape, the words “Not available” will flash and an error message will appear. To correct this, stop the tape.

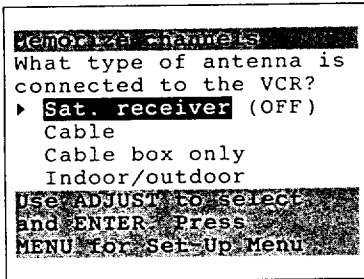

- 4 You will see the menu for automatically memorizing channels. If you are using an RCA satellite receiver, turn the ADJUST dial to select "Sat. receiver," then use the shuttle ring to change "OFF" to "1." If you are not using a satellite receiver, make sure "Sat. receiver" is set to "OFF."
- 5 Using the list below as a reference, turn the ADJUST dial to select the kind of antenna you connected.
  - If you are using a cable box that sends signals to your VCR on only one channel and can be operated by a remote control, choose "Cable box only," and skip to step 7, below.
  - If you are using any other cable combination, including a cable box with an A/B switch, choose "Cable."
  - If you are using an antenna that receives only over-the-air broadcasts, such as "rabbit ears" or a roof-mounted antenna, choose "Indoor/outdoor."

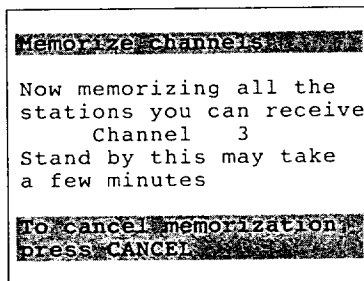

After you have selected, turn the shuttle ring right.

- 6 If you choose "Cable" or "Indoor/outdoor," an on-screen message and the display on the front of your VCR will show you that the VCR is memorizing the stations you can receive. You can cancel the memorization at any time by pressing CANCEL on the remote control. After the VCR has programmed all the channels, the screen will return the VCR's picture.

► **Important:** Automatic programming may include vacant channels if there are stray signals or noise on those channels. If this occurs, you can manually delete the channels using the procedure in the section "Adding and deleting channels."

**If you choose "Cable box only,"**

You need to tell the VCR which manufacturer makes your cable box, and on which channel the cable box sends a signal. You will see the screen to the left.

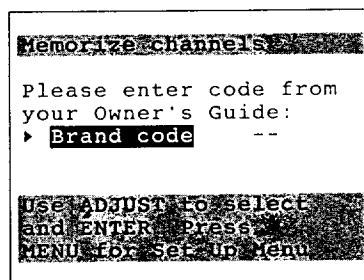

- 7 The cursor will be next to "Brand code." Turn the ADJUST dial or press the number buttons to select the manufacturer's code number for your cable box. The codes are listed below:

Manufacturer	Code Number	Manufacturer	Code Number	Manufacturer	Code Number
ABC	1, 2, 11	Magnavox	59, 61, 67	Sheritech	57
Archer	29, 58, 65	Movietime	30, 31, 51, 54	SL Marx	5, 14, 29
Century	29, 65	NSC	20, 51, 52	Sprucer	14, 21, 25
Citizen	29, 65	OAK	27, 39, 40, 49, 50, 61	Stargate	5, 14, 29, 65
Diamond	54, 58	Panasonic	14, 21, 25	Sylvania	66
Eagle	17, 18, 19, 61, 62, 63	Paragon	6, 7	Teknika	36
Eastern	68	Pioneer	14, 15, 16, 92, 93, 94	Texscan	53, 66
G C Electronic	29, 65	Philips	26, 61, 62, 63, 64	Tocom	1,2,3,4,5,41,42,43,44,69,91
Gemini	5, 60	RCA	14, 21, 25	Toshiba	32, 33, 34
General Electric	35	Realistic	37, 38	Unika	48
General Instrument	1,2,3,4,5,41,42,43,44,69,91	Regal	45, 48	United Cable	2
Hamlin	22, 23, 45, 46, 47	Regency	68	Universal	30, 31, 54, 65
Hitachi	24	Rembrandt	55, 56	Videoway	6, 7
Jerrold	1,2,3,4,5,41,42,43,44,69,91	Samsung	5, 14, 21, 25, 29	Viewstar	17, 18, 19, 61, 62, 62
Macom	28	Scientific Atlanta	10, 11, 12, 13	Zenith	6, 7, 8, 9

**Memorize channels**

Your cable box sends a signal on which channel?

Brand code 1

▶ **Channel** 3

Use ADJUST to select and ENTER. Press MENU for Set-Up Menu

**Memorize channels**

Your cable box sends a signal on which channel?

Brand code 1

▶ **Channel** L1

Use ADJUST to select and ENTER. Press MENU for Set-Up Menu

**Memorize channels**

Now memorizing all the stations you can receive

Channel 3

Stand by this may take a few minutes

To cancel memorization press CANCEL

- 8 After you have selected the manufacturer's code, turn the shuttle ring right. The cursor will move to "Channel."
- 9 Use the ADJUST dial to select the channel on which your cable box sends a signal to the VCR. If you connected your cable box with audio/video cables, use the INPUT button to select "L1" if you connected them to the rear panel or "L2" if you connected them to the front panel.
- 10 You need to determine whether or not you have selected the correct "Brand Code." To do this, press the CHANNEL buttons on the remote control. As you press the buttons, the channel number on the front of your VCR should change. Watch your cable box. Your cable box should show the exact same number a moment after it appears on your VCR.

If your cable box does not change channels at all, or does not show the exact same number, do one of the following:

- Try moving the cable box on top of the VCR.
- If more than one "Brand Code" is listed for your type of cable box, try a different one. (You can use the CANCEL button to move back to the "Brand Code" option.)

- 11 After you have determined that you are using the correct Brand Code, turn the shuttle ring right to begin memorizing channels. The TV screen will show you a message that the VCR is memorizing the channels coming from your cable box. Your TV screen, the front of your VCR, and your cable box should all display each channel number, one by one.

When the VCR is finished memorizing, it will return to the VCR's picture.

▷ **Important:** If no code number is listed for your cable box, or if none of the numbers listed will work, try each code, from 01 to 94.

If your cable box cannot be operated by a remote control (i.e., if it is operated with a mechanical dial or slide), then your VCR will not be able to change channels on the cable box.

If your cable box will not respond to any of the codes, your VCR cannot change channels on the cable box. You will need to change channels yourself, using the cable box's remote control. You should re-program your VCR, choosing "Cable" in step 5 on page 34. When programming to record, you will need to leave your cable box ON and tuned to the channel you wish to record.

If you connected a satellite receiver, press the CHANNEL buttons to see that the TV shows the channels coming from the receiver. If it does not, try repositioning or moving the satellite receiver.

▷ **Important:** Automatic programming may include vacant channels if there are stray signals or noise on those channels. If this occurs, you can manually delete the channels using the procedure in the section "Adding and deleting channels."

## Using video mute

When you turn video mute ON, any blank section of tape, or any station with a weak signal, will be replaced by a blue screen. The sound will also be turned off. If there is a time when you would like to try to tune in a weak station, turn video mute OFF.

Before you begin, you should know how:

- to view the picture coming from your VCR; (see page 25)
- to use the menus. (See page 31.)

```

◆ First Time Set-Up
Your choices are:
  Set the clock
  ▶ Customize choices
    Memorize channels
    Add/delete channels
    Set VCR Plus+ Guides
Use ADJUST to select
and ENTER.
Press MENU for Main Menu
  
```

```

Customize choices
PerfectTape      (AUTO)
▶ Video mute     (ON )
A/V Network     (OFF)

Use ADJUST to select,
and ENTER to change
settings. Press
MENU for Set-Up Menu
  
```

- 1 Press the MENU button on the remote control. The "VCR Main Menu" appears on your TV.
- 2 Use the ADJUST dial on the remote to move the cursor next to "First Time Set-Up." Turn the shuttle ring right.
- 3 The "First Time Set-Up" menu appears on your screen. Use the ADJUST dial to move the cursor next to "Customize choices" and turn the shuttle ring right.
- 4 Use the ADJUST dial to select "Video mute." Then, turn the shuttle ring to set video mute to ON or OFF.
- 5 Press the MENU button once to return to the "First Time Set-Up" menu; press the MENU button a second time to return to the "VCR Main Menu;" press the MENU button a third time to turn off the menus.

## Adding and deleting channels

If necessary, you can manually add or delete channels after you have completed the automatic channel programming. (You cannot do this for channels coming from a satellite receiver.)

Before you begin, you should know how:

- to view the picture coming from your VCR; (see page 25)
- to use the menus. (See page 31.)

```

◆ First Time Set-Up
Your choices are:
  Set the clock
  Customize choices
  Memorize channels
  ▶ Add/delete channels
    Set VCR Plus+ Guides
Use ADJUST to select
and ENTER.
Press MENU for Main Menu
  
```

- 1 Make sure that video mute is ON. (See above.)
- 2 Press the MENU button on the remote control. The "VCR Main Menu" appears on your TV.
- 3 Turn the ADJUST dial on the remote control to move the cursor next to "First Time Set-Up." Turn the shuttle ring right.
- 4 You will see the "First Time Set-Up" menu. Turn the ADJUST dial to move the cursor next to "Add/delete channels." Turn the shuttle ring right.

► **Important:** If you are recording or playing back a tape, or if you are watching a channel from a satellite receiver, then the words "Not available" will flash and you will see an error message.

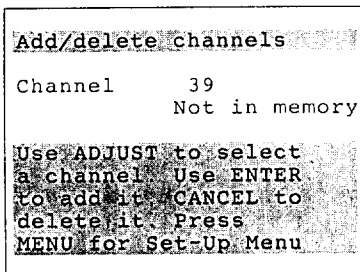

- 5 You will see the screen for adding or deleting channels. Use the ADJUST dial to select the channel that you want to add or delete. Press the ENTER button or turn the shuttle ring right to add the channel; press the CANCEL button or turn the shuttle ring left to delete it.
- 6 When you are finished adding or deleting channels, press the MENU button once to return to the "First Time Set-Up" menu; press the MENU button a second time to return to the "VCR Main Menu"; press the MENU button a third time to turn off the menu.

▷ **Important:** If you use automatic programming again, you will lose all of the manual changes you made. All of the channels you deleted will be added; all of the channels you added will be deleted. If you are using a cable box that receives only one or two digit channels, you cannot add a three-digit channel.

### Selecting a channel

Now that you have programmed your channels, and added or deleted some, you will want to be able to select channels. (If you have not yet programmed your channels, see page 33.)

There are two basic ways to select channels: sequentially or directly. You can also use the super quick view memory.

#### selecting channels sequentially

Press the CHANNEL buttons on the remote control or turn the jog dial on the VCR front panel. This will cycle through the channels in sequential numerical order. If you have connected your VCR to a satellite receiver, you can change channels in 10-digit increments by holding down the CHANNEL button for one second or by turning the jog dial quickly.

#### selecting channels directly

Use the number buttons on the remote control. For example, to choose channel 23, press the "2" button, then the "3" button.

To select a single digit channel, such as channel 5, press the "0" button, then the number button, "5." You can also press the number button "5," then turn the shuttle ring right.

▷ **Important:** The VCR can receive UHF/VHF channels 2–69, cable box channels 1–99, cable channels 1–125, and satellite channels 100–999. If you try to select a channel number that the VCR cannot receive, the VCR will not change channels. If you are using a satellite receiver, you cannot select cable channels 100–125.

#### using super quick view memory

Super quick view lets you quickly switch to your favorite channels. To use super quick view, you add channels to the super quick view memory, then use the Q.V. button to cycle through those channels.

To add a channel to the super quick view memory:

- ❶ Select the channel you want to add, either with the CHANNEL button or the number buttons.
- ❷ While the channel number is still on the screen, turn the shuttle ring right on the remote control. The letters "SQV" will appear, indicating that the channel has been added to the super quick view memory.

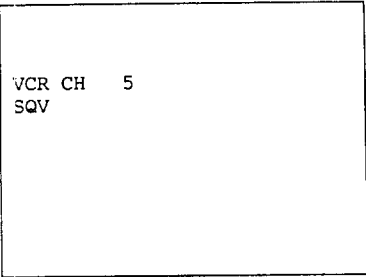

VCR CH 5  
SQV

Now, when you press the Q.V. button, you will cycle through all of the channels you added to the super quick view memory.

To remove a channel from the super quick view memory:

- ❶ Select the channel you want to remove, either with the CHANNEL button, the number buttons, or the Q.V. button.
- ❷ While the channel number is still on the screen, press the CANCEL button on the remote control or turn the shuttle ring left. The letters "SQV" will disappear, indicating that the channel has been removed from the super quick view memory.

## ◆ Setting the VCR Plus+ Guide Channel Numbers

The VCR Plus+ system allows you to program your VCR to record television shows by simply entering a PlusCode number found after each program in your TV listings.

VCR Plus+ assigns a unique number to each channel in your area. You must do a one-time set-up of your VCR using these assigned guide channel numbers in order to record correctly when using the PlusCode numbers.

### A special note to cable box subscribers

*If your local cable company scrambles some or all stations, and/or requires you to use a cable box, then you may need to take an extra step when using VCR Plus+ to program your VCR.*

- *If the HS-U760 is able to control your cable box (and you have chosen "Cable box only" when you memorized channels), simply follow the instructions below.*
- *If the HS-U760 is unable to control your cable box (or you have chosen "Cable" when you memorized channels), you will need to set all of the VCR Plus+ Channel Guides to the channel on which your cable box sends a signal (usually channel 3 or 4). Then, when you program, leave your cable box turned ON, tuned to the channel you wish to record.*

*If you have difficulty recording, your cable company may be able to suggest an alternative hook-up method that will allow you to use VCR Plus+ without leaving the cable box on, or they may be able to provide additional solutions. Contact them for more help.*



**Before you begin, you need:**

- to know how to view the picture coming from your VCR; (see page 25), and
- to know how to use the menus. (See page 31.)

▷ **Important:** Most importantly, you need to have a list of the VCR Plus+ Channel Guides for your area. This list can be found in *TV Guide*. Your local newspaper or your cable company may also be able to provide you with this list.

**To set the VCR Plus+ Channel Guides:**

Complete the following set-up procedure only for each station whose assigned guide channel number is different from the channel number that you receive it on. For example, if the guide channel number for HBO is 33, and your VCR receives HBO on 27, you need to “set up” these numbers using the procedure described below. For channels whose guide numbers are the same (for example, if the guide number for HBO is 33, and your VCR also receives HBO on 33), you can skip this set-up procedure.

- 1 Press the MENU button on the remote control. Turn the ADJUST dial to move the cursor next to “First Time Set-Up.” Turn the shuttle ring right.
- 2 The “First Time Set-Up” menu appears on your screen. Turn the ADJUST dial to move the cursor next to “Set VCR Plus+ Guides.” Turn the shuttle ring right.
- 3 You will see the “Set VCR Plus+ Guides” menu on your screen. In the “Plus Guide” column on the left is a list of the VCR Plus+ guide channel numbers, and in the “BOX Channel” or “VCR Channel” column on the right is a list of the actual channels your VCR receives in your home.
- 4 Turn the ADJUST dial to place the cursor next to a VCR Plus+ guide number for the channel you want to set. For example, if you want to set HBO, and if the VCR Plus+ guide channel number for HBO is “33,” move the cursor next to “33.” You may have to cycle through a number of “screens” before the higher number guide channels are displayed on the screen.

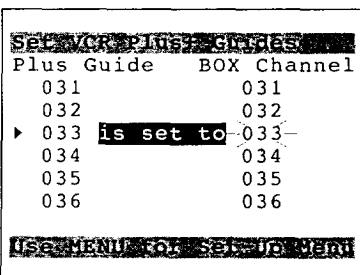
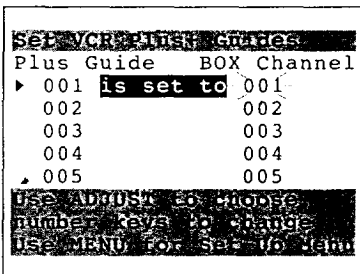
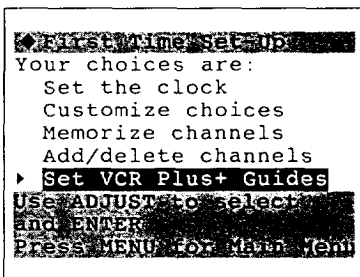

Set VCR Plus+ Guides	
Plus Guide	BOX Channel
031	031
032	032
▶ 033	is set to 027
034	034
035	035
036	036

Use MENU for Set-Up Menu

- Use the number buttons to enter the actual VCR channel on which you receive the station. For example, if your VCR receives HBO on channel 27, enter the number "27" next to the VCR Plus+ guide channel for HBO.

If you are using a cable box that the VCR cannot control, enter the channel on which your cable box sends signals to your VCR (usually channel 3 or 4).

- To change more guide channel numbers, repeat steps 4 and 5. When you are finished, press the MENU button three times to exit the menus.

## ◆ Recording

Your new VCR offers a wide variety of recording options that take full advantage of our advanced electronics. This section tells you about the following recording procedures:

- Recording a current broadcast,
- Programming your VCR to record,
- Programming with VCR Plus+,
- Using Quick Program,
- Using One-Touch Recording (OTR),
- Using One Key Programming, and
- Notes about programmed recording.

### Recording a current broadcast

Before you begin, you need to know how:

- to view the picture coming from your VCR. (See page 25.)

To record a TV program that is currently playing:

- Load a tape with its erasure tab intact into the VCR. If you have not yet recorded on this tape, the VCR will test the tape with the PerfectTape feature. For more information on this feature, please see page 56.
- Set the VCR's input to tuner. To do this, press the INPUT button on the front panel or on the remote until the channel display shows on-screen or on the front panel.
- If you have not already done so, set the speed at which you would like to record. (See "Selecting and adjusting the audio and video functions" on page 29.)
- Select the channel you would like to record by using the CHANNEL button or the jog dial on the front panel. (If you are using a cable box that the VCR cannot control, select channel 3 or 4 on the VCR, and change the channel on the cable box, not on the VCR.)

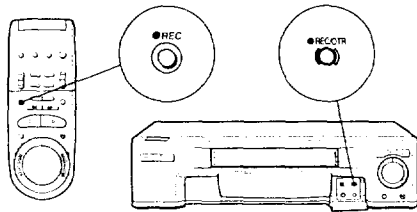

- 5 Press the record button (REC) on the remote control or the record button (REC/OTR) on the front panel of the VCR.

Recording will start. When you reach the end of the tape, the VCR will automatically rewind. You can stop recording at any time by pressing the STOP or PAUSE button. To resume recording from STOP, press REC. To resume recording from PAUSE, press PAUSE. (You cannot use the REC/OTR button to resume recording from PAUSE.)

▷ **Important:** If you pause the VCR for five minutes, recording will stop automatically to protect the tape. If you record in extended play (EP), you will only be able to play the tape on a VCR equipped for EP play, such as this one. If you attempt to record on a tape that has had its erasure prevention tab removed, the VCR will eject the tape and briefly display an error message on your TV screen.

#### using the record level

While recording, you can manually adjust the Hi-Fi soundtrack. To do this, set the "Monitor" audio function to STEREO and the "Level meter" function to ON. Then, adjust the REC LEVEL control while observing the peak level meters. The meters are divided into green and red sections. Adjust the REC LEVEL control so that the green bars are lit, with the red bars only occasionally lit.

#### using record cancel

Record cancel allows you to stop a recording you started accidentally and then rewind the tape to the point where recording started. You can use record cancel only if you start recording from the record-pause mode. To use record cancel, press the rewind button (REW) or turn the shuttle ring on the front panel left within eight seconds of when you accidentally started recording. The VCR rewinds to where the recording started and enters the record-pause mode.

### Programming your VCR to record

You can program your VCR to record with the help of Mitsubishi's on-screen operating system. You can schedule up to eight recording "events" within a one month period.

#### Before you begin, you must:

- know how to view the picture coming from your VCR; and
- have set the clock. (See page 31.)

To program your VCR to record:

- 1 Load a tape with its erasure tab intact into the VCR. If you have not yet recorded on this tape, the VCR will test the tape with the PerfectTape feature. For more information on this feature, please see page 56.

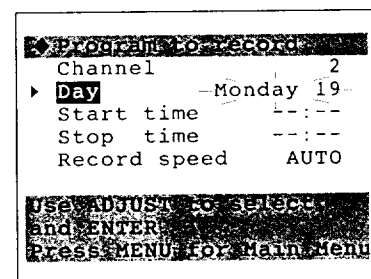
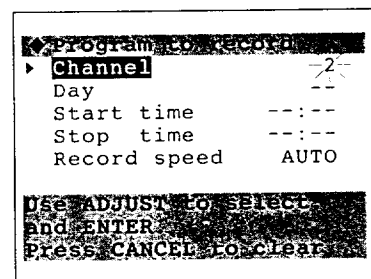
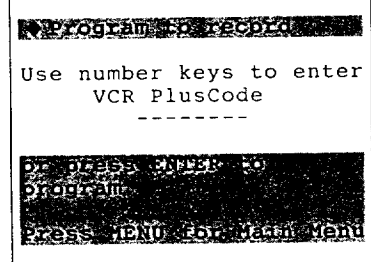
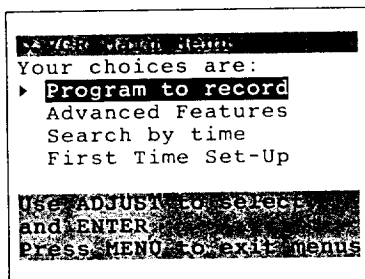

- 2 Press the MENU button on the remote control. The "VCR Main Menu" appears on your screen. Use the ADJUST dial on the remote control to move the cursor next to "Program to record." Turn the shuttle ring right.

If there is at least one programmed recording already entered, you will see the "recap" screen. You can choose an empty recording slot, or wait four seconds and the VCR will automatically choose the first empty slot.

- 3 You will see the VCR Plus+ "Program to record" menu. (For more information on using VCR Plus+ to program your VCR, see page 44.) Turn the shuttle ring right to skip this screen.

- 4 You will see the "Program to Record" menu. Turn the ADJUST dial to choose the channel you would like to record (for example, channel 2). Turn the shuttle ring right.
  - If you are using a cable box that the VCR cannot control, enter the channel number on which the cable box sends a signal to your VCR (usually channel 3 or 4).
  - If you wish to record from an external source, press the INPUT button or turn the ADJUST dial until "External L1" or "External L2" appears. Select "External L1" to record from an external source connected to the rear panel; select "External L2" to record from an external source connected to the front panel.
  - If you are recording from a satellite receiver, you do not need to select "L1." Simply choose the channel you would like to record (for example, channel 245.)

- 5 The "Day" will flash. Turn the ADJUST dial to highlight the day on which you want to record (for example, Monday the nineteenth). Turn the shuttle ring right.

▷ **Important:** When selecting a day, your choices are: a single day up to one month away, every day from Monday through Friday, or the same day every week. To program for every day from Monday through Friday (to tape a soap opera, for example), turn the ADJUST dial until "Monday-Friday" appears. To program the same day every week (to tape your favorite weekly sitcom, for example), turn the ADJUST dial until "Every" and the desired day of the week appear.

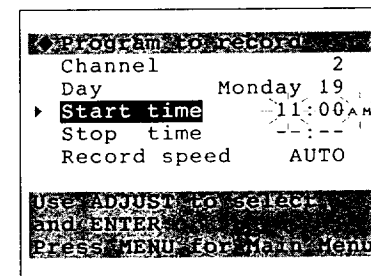

- 6 The hour numbers of the starting time, along with the am/pm indicator, will flash. Turn the ADJUST dial to set the hour when you wish recording to start. Turn the shuttle ring right.

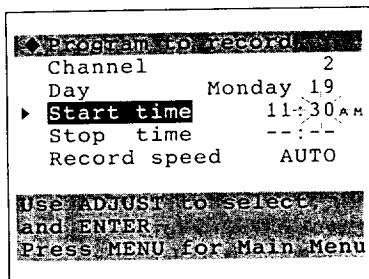

- 7 The minute numbers of the start time will flash. Turn the ADJUST dial to set the minutes when you wish recording to start. Turn the shuttle ring right.

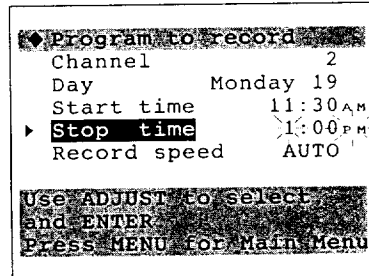

- 8 The hour numbers of the stop time, along with the am/pm indicator, will flash. Turn the ADJUST dial to set the hour when you wish recording to stop. Turn the shuttle ring right.

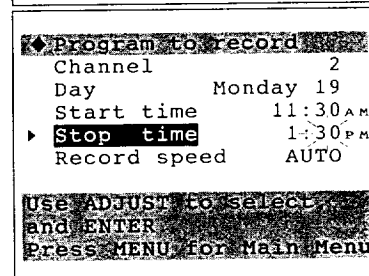

- 9 The minute numbers of the stop time will flash. Turn the ADJUST dial to set the minutes when you wish recording to stop. Turn the shuttle ring right.

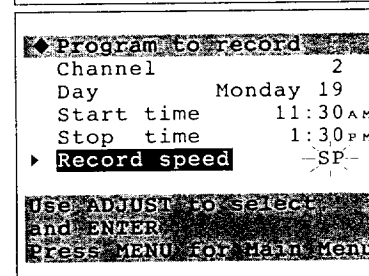

- 10 Turn the ADJUST dial to set the recording speed (SP, EP, or auto recording speed (AUTO)). (See "auto speed programming" on page 50 for an explanation of the auto speed recording feature.) Turn the shuttle ring right.

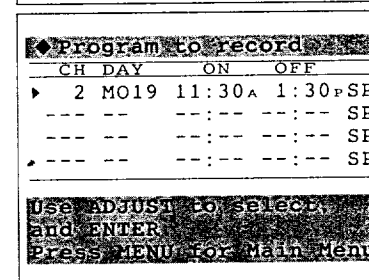

- 11 The contents of the programmed memory will appear on the "recap" screen.
- 12 To program additional recording times, select an empty program line by turning the ADJUST dial. Then, turn the shuttle ring right. You will return to the VCR Plus+ "Program to record" screen. Continue the programming procedure from step 3.

► **Important:** Only four of the eight program lines appear on-screen at any one time. To see additional program lines, turn the ADJUST dial to scroll the lines on the screen.

- 13 When you are finished with all programming, turn the VCR power OFF and make sure the programmed recording light (□) is lit. However, if you have a cable box, leave it turned ON. Additionally, if the HS-U760 does not control your cable box, leave the box tuned to the station you wish to record.

### changing settings while programming

If you wish to change one of your settings (such as start time) while you are programming, turn the shuttle ring on the remote to select the setting you wish to change. Turning the ring right will move you forward through the list, while turning the ring left will move you backwards. Then, use the ADJUST dial to change the setting.

- ▷ **Important:** If you turn the shuttle ring left while the cursor is next to the channel number, you will cancel the entire program.

### Programming with VCR Plus+

VCR Plus+ allows you to program your VCR to record by simply entering a VCR Plus+ number. You can find this number in *TV Guide* or (possibly) your local TV listings.

#### Before you begin,

- you need to know how to view the picture coming from your VCR; (see page 25)
- you must have set the clock; (see page 31) and
- you must have set your VCR Plus+ Channel Guides. (See page 38.)

- 1 Load a tape with its erasure tab intact into the VCR.

If you have not yet recorded on this tape, the VCR will test the tape with the PerfectTape feature. For more information on this feature, please see page 56.

- 2 Press the MENU button on the remote control. The “VCR Main Menu” appears on your screen. Use the ADJUST dial on the remote control to move the cursor next to “Program to record.” Turn the shuttle ring right.

If there is at least one programmed recording already entered, you will see the “recap” screen. You can choose an empty recording slot, or wait four seconds and the VCR will automatically choose the first empty slot.

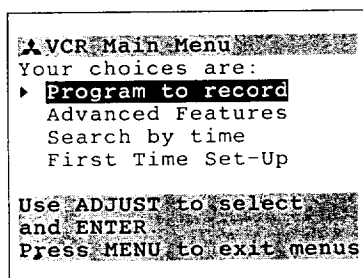

- 3 You will see the VCR Plus+ “Program to record” screen. Use the number buttons on the remote control to enter the PlusCode number for the television show you want to record. For example, if the PlusCode number for the program you want to record is 5678, simply enter “5678.”

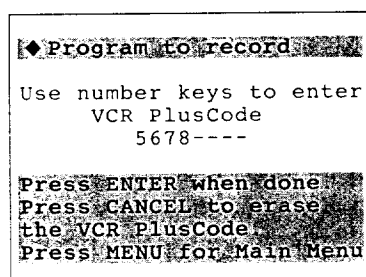

- 4 If you enter a number incorrectly, turn the shuttle ring left or press the CANCEL button on the remote control. When you have finished entering the PlusCode number, turn the shuttle ring right.

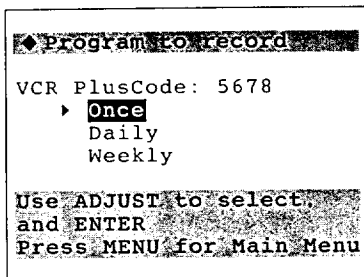

- 5 Use the ADJUST dial to select whether you want to record your program once, daily, or weekly.
  - If you choose “Once,” your VCR will only record the show once.
  - If you choose “Daily,” your VCR will record the same channel at the same time, Monday through Friday.
  - If you choose “Weekly,” your VCR will record the same channel at the same time, on the same day, each week.

After you have made your choice, turn the shuttle ring right.

▷ **Important:** If two programmed recording times overlap, the message, “VCR is already programmed for that time” will display on the screen. You will need to erase the previous program before you can enter the new one. If the code number you entered is wrong, the message, “VCR PlusCode, Not a valid code” will display on the screen.

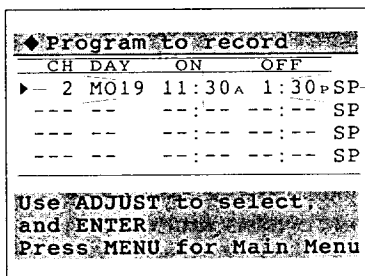

- 6 The program you have chosen to record will appear in the “recap” format, and will flash for three seconds.
- 7 If you wish to change the record speed, turn the shuttle ring right repeatedly until the record speed is flashing. Change the recording speed by turning the ADJUST dial. When finished, turn the shuttle ring right once more.
- 8 To program additional recording times, select an empty program line by turning the ADJUST dial. Then, turn the shuttle ring right. You will return to the VCR Plus+ “Program to record” screen. Continue the VCR Plus+ programming procedure from step 3.
- 9 When you are finished with all programming, turn the VCR power OFF and make sure the programmed recording light (☐) is lit. However, if you have a cable box, leave it turned ON. Additionally, if the HS-U760 does not control your cable box, leave the box tuned to the station you wish to record.

### Using Quick Program

Quick Program is an exclusive Mitsubishi feature that simplifies the process of programming your VCR to record. When you press the QUICK PROGRAM/VCR Plus+ button on the remote control, you will immediately see the VCR Plus+ “Program to record” menu and can begin programming right away.

You can use this feature even when the VCR is stopped, playing, recording, fast forwarding, rewinding, or off. However, the QUICK PROGRAM/VCR Plus+ button does not function during One Key Programming.

Quick Program is also an “Active A/V Network” feature. If you have a Mitsubishi TV with Active A/V Network, see page 64 for more information.

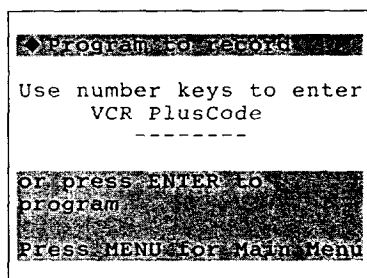

CH	DAY	ON	OFF
▶ 2	MO19	11:30A	1:30P SP
10	TH22	9:00P	10:00P EP
7	E-WE	8:00A	9:00A EP
29	FR23	5:30P	5:45P EP
8	TU27	11:00P	0:30A SP
33	M-F	7:00P	7:15P EP
15	SA 1	8:00P	9:00P EP
46	SU25	7:00A	9:00A SP

To use quick program:

- 1 Press the QUICK PROGRAM/VCR Plus+ button on the remote control. If the VCR is off, it will turn on. After tuning your TV to the correct channel or input, you will see the VCR Plus+ “Program to Record” screen.

If the VCR’s memory is full, you will see the recap screen (below left) instead of the VCR Plus+ “Program to Record” screen. You will need to use the CANCEL button to erase an entry before you can add another one.

- 2 Complete programming as described in “Programming your VCR to record,” or “Programming with VCR Plus+.” When you are finished, press the QUICK PROGRAM/VCR Plus+ button again. If the VCR is stopped, it will turn off and be ready to record your program at a later time. If the VCR is playing, recording, fast forwarding or rewinding, the menus will turn off, but the VCR power will remain on.

When you are finished with all programming, be sure the VCR power is OFF and the programmed recording light (☐) is lit. However, if you have a cable box, leave it turned ON. Additionally, if the HS-U760 does not control your cable box, leave the box tuned to the station you wish to record.

▷ **Important:** If you press the QUICK PROGRAM/VCR Plus+ button, but the clock is not set, you will see the “Set the clock” menu.

If you have set the A/V Network to ACTIVE, you should point your remote control at the television when using Quick Program.

### Using One-Touch Recording (OTR)

One-Touch Recording (also called OTR) is a way to begin recording immediately, but have your VCR stop recording and turn off automatically after your show is over.

**Before you begin, you need to know how:**

- to view the picture coming from your VCR. (See page 25.)

- 1 Load a tape with its erasure tab intact into the VCR. If you have not yet recorded on this tape, the VCR will test the tape with the PerfectTape feature. For more information on this feature, please see page 56.
- 2 Set the VCR’s input to tuner. To do this, press the INPUT button on the front panel or on the remote control until the channel display shows on-screen or on the front panel fluorescent display.
- 3 Use the CHANNEL buttons on the remote control or the jog dial on the front panel to select the channel you would like to record.



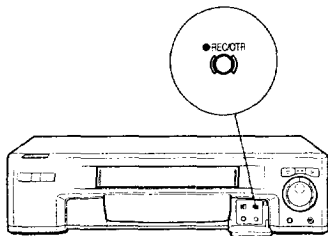

If you are using a cable box that the VCR does not control, select channel 3 or 4 on the VCR, and change the channel on the cable box.

- ④ Press the REC/OTR button on the front panel twice. The first time you press the button, recording will begin. The second time you press the button, 30 minutes is added to the OTR timer, which is displayed on the front panel. (You can also use the OTR/OFF-T button on the remote control. When you first press this button, the VCR will begin recording and 30 minutes is added to the OTR timer.)
- ⑤ Press the REC/OTR button or OTR/OFF-T button for each 30 minutes you want to add to the OTR timer, up to 4 hours. If you press the button 10 times, you will see the word "End" on the front panel display. The VCR will record until the end of the tape. If you press the button an eleventh time, the VCR will resume normal recording.

The OTR timer will begin to count down. When it reaches zero, the VCR will stop recording and turn off. If you have previously programmed your VCR to record, the VCR will be ready to record what you've programmed. If the end of the tape is reached before OTR is finished, the VCR will stop and the power will turn off.

▷ **Important:** If you attempt to record on a tape that has had its erasure prevention tab removed, the VCR will eject the tape. In addition, the VCR will briefly display an error message on your TV screen.

If you program too much time into the OTR timer, continue pressing the REC/OTR button or OTR/OFF-T button. You will "cycle" around once you have reached the 4-hour point. You can start over, adding time in 30 minute intervals.

#### how OTR affects other controls

If you press the PAUSE button during OTR, the VCR will pause recording, but the OTR timer continues to count down.

If you press STOP during OTR, you erase the OTR programming.

You cannot use the REC/OTR button on the front panel to resume recording from the record-pause mode.

### Using One Key Programming

One Key Programming is a programming method that is simple to use and easy to learn, without using the remote control.

#### Before you begin,

- you need to know how to view the picture coming from your VCR; (see page 25) and
- you must have set the clock. (See page 31.)

To use One-Key Programming:

- 1 Load a tape with its erasure tab intact into the VCR.

If you have not yet recorded on this tape, the VCR will test the tape with the PerfectTape feature. For more information on this feature, please see page 56.

- 2 Press the ONE KEY PROGRAM button. (If you have not set the time, the “Set the Clock” menu will appear. Set the clock, and then proceed.) If there is already a program in the VCR’s memory, you will see the “recap” screen. You can use the ONE KEY PROGRAM button to select an empty programming slot, or you can wait 4 seconds for the VCR to automatically select an empty slot.

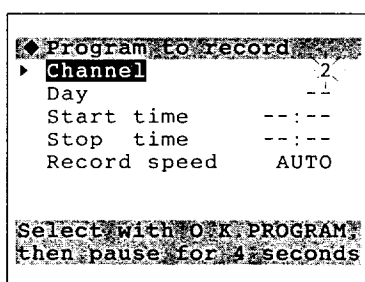

- 3 You will see the “Program to Record” screen. Press the ONE KEY PROGRAM button until the channel you would like to record (for example, channel 2) appears. Then, wait for 4 seconds. The cursor will move down to the next position, “Day.” (If you are recording from a cable box that the VCR cannot control, set the channel to 3 or 4, whichever the cable box sends signals on.)

► **Important:** If you wish to record from an external source, press the ONE KEY PROGRAM button until “External L1” or “External L2” appears.

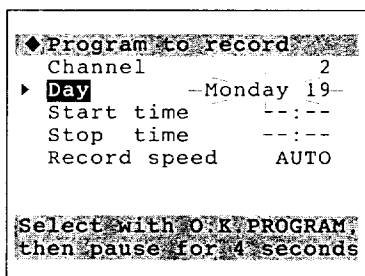

- 4 Press the ONE KEY PROGRAM button to choose the day you would like to record (for example, Monday the nineteenth). Then, wait for 4 seconds. The cursor will move to the starting time, and the hours will flash.

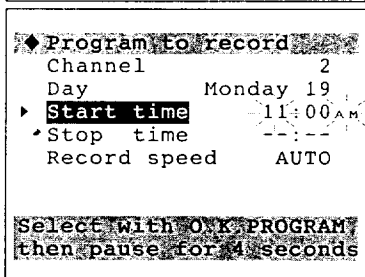

- 5 Press the ONE KEY PROGRAM button to choose the hour when you wish recording to start. Then, wait for 4 seconds. The minute numbers will begin to flash.

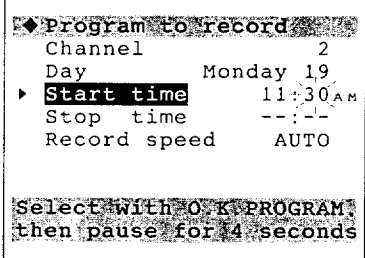

- 6 Press the ONE KEY PROGRAM button to choose the minute when you wish recording to start. Then, wait for 4 seconds. The cursor will move to “Stop time.”

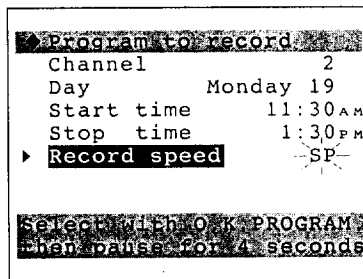
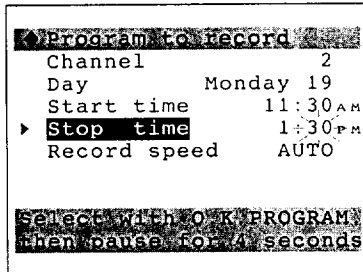
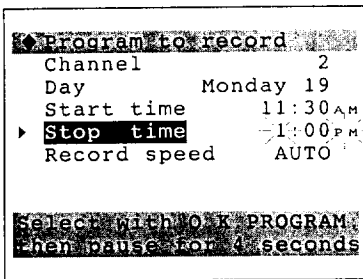

7 Press the ONE KEY PROGRAM button to choose the hour when you wish recording to stop. Then, wait for 4 seconds. The minute numbers will begin to flash.

8 Press the ONE KEY PROGRAM button to choose the minute when you wish recording to stop. Then, wait for 4 seconds. The record speed will flash.

9 Press the ONE KEY PROGRAM button to set the recording speed. After 4 seconds, the menus will turn off.

10 When you are finished with all programming, turn the VCR power OFF and make sure the programmed recording light (☐) is lit. However, if you have a cable box, leave it turned ON. Additionally, if the HS-U760 does not control your cable box, leave the box tuned to the station you wish to record.

The VCR is ready to record what you've programmed. If you want to exit One Key Programming, press STOP.

#### changing settings while programming

If you make a mistake when using One Key Program:

- 1 Turn the shuttle ring on the front panel to move the cursor to the setting you wish to change. Turning the ring right will move you forward, while turning the ring left will move you backward. If you wish to use the remote control, you can use ENTER to move forward or CANCEL to move backward.
- 2 Once you have chosen a setting, you can change it by using the jog dial on the front panel or the ADJUST dial on the remote control.
- 3 Once you have corrected the setting, turn the shuttle ring right or press ENTER on the remote control to resume your place.

▷ **Important:** If you press CANCEL or turn the shuttle ring left while the cursor is next to the channel number, you will cancel the entire program. If you want to stop using One Key Programming, press the STOP button.

### Notes about programmed recording

- ▷ **Important:** You cannot use the VCR when the programmed recording light (☐) is lit. If you want to use the VCR before programmed recording begins, press the POWER button on the remote once. This turns the programmed recording light off and the VCR on.

If you use the POWER button on the front panel for this purpose, you will have to press it twice. Pressing it once turns off the programmed recording light; pressing it a second time turns the VCR on.

When you are finished using the VCR, turn the VCR power off again, either with the POWER button on the remote or the POWER button on the front panel. Make sure the programmed recording light is back on.

After a program has been recorded, the VCR memory is cleared (unless you have scheduled the VCR to record the program every day or every week).

If there is already a program in the VCR's memory, you will see the "recap" screen when you bring up the menus for programming to record (unless you are programming with the QUICK PROGRAM/VCR Plus+ button). If the VCR's memory is full, you must erase a program before you can enter a new one.

If a tape runs out during programmed recording, the VCR ejects the tape and the programmed recording light (☐) and the tape status symbol (⊙) will flash. Load a new tape and press the REC button. The VCR will resume recording. Do not overlap the recording times you program.

- ▷ **Important:** Remember that when your VCR is off, it may also be in stand-by for programmed recording. Also remember that the VCR, when programmed, will record over the next section of tape. So, to avoid recording over tapes you want to save, remember that the VCR automatically shuts off during OTR recording and "rewind & off."

Your VCR will not record over a tape that has the erasure prevention tab removed (see "Preventing accidental erasure"). All rental movies have this tab removed, so they are safe from being accidentally erased.

#### auto speed programming

Use auto speed programming if you want to record as much of the program as possible in standard play (SP) speed, but you want the VCR to automatically switch to extended play (EP) if there is not enough tape left.

Auto speed programming is only available in the first programming slot. In this first slot, the recording speed is automatically

set to AUTO. If you want to use auto speed programming in this programming slot, you don't need to change anything.

▷ **Important:** Make sure that the "Tape" video function matches the kind of tape you are using. (See "Selecting and adjusting the audio and video functions" on page 29.)

Set the time for recording to end a minute or two beyond the program's scheduled broadcast time.

#### programming TV programs that end on the day after

If you want to start the recording at 11:00 PM and end it at 2:00 AM the next day, simply set the start time to 11:00 PM on the recording start day and the end time to 2:00 AM. There is no need to change the day of the week.

#### skipping programs

If you have already entered a program into your VCR's memory, you can skip the program without going into the VCR's menus. Simply press the POWER button on the front panel once. The programmed recording light (☐) will turn off, and the program will be skipped. If you decide not to skip the program, press the POWER button on the front panel twice; the programmed recording light will light up again.

#### changing programmed recording settings

If you want to change the programmed recording settings:

- ❶ Turn the VCR on with the POWER button.
- ❷ Press the MENU button on the remote control.
- ❸ Turn the ADJUST dial to select "Program to record." Turn the shuttle ring right. You'll see the "recap" screen.
- ❹ Turn the ADJUST dial to place the cursor next to the program you wish to change. Turn the shuttle ring right. You will see the "Program to record" menu.
- ❺ Repeatedly turn the shuttle ring right to place the cursor next to the item you wish to change. Use the ADJUST dial to change it.
- ❻ Use the MENU button to turn off the menus. Then, use the POWER button to turn off the VCR. Make sure the programmed recording light is on.

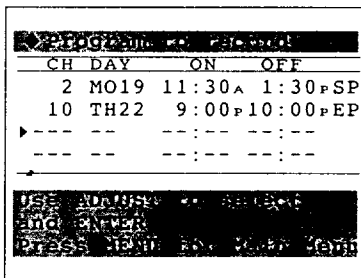

◆ Program to record			
CH	DAY	ON	OFF
2	MO19	11:30A	1:30P SP
10	TH22	9:00P	10:00P EP
▶	----	----	----
----	----	----	----

Use ADJUST to select  
and ENTER  
Press MENU for Main Menu

#### canceling a programmed recording

- ❶ Press POWER to turn the VCR on.
- ❷ Press the MENU button on the remote control. The “VCR Main Menu” appears on your screen. Use the ADJUST dial on the remote control to move the cursor next to “Program to record.” Turn the shuttle ring right.
- ❸ You will see the “recap” screen. Use the ADJUST dial to place the cursor next to the program you wish to cancel.
- ❹ Press the CANCEL button. The program is erased.
- ❺ Press the MENU button once to return to the Main Menu; press it again to turn off the menus.

#### using the TIMER RESET button

You can use the TIMER RESET button on the rear panel to erase both the time and all programmed recordings.

To use the TIMER RESET button, press it with a pencil or a ball point pen. The power will turn off and the clock will reset. All programmed recording is erased.

Additionally, the TIMER RESET button will reset the on-screen language you selected. The next time you use the menus, you will have to select the on-screen language. (See page 28.)

#### loading a tape for programming

If, after programming, you forget to load a tape, or if you load a tape with its erasure tab removed, then the programmed recording light and the tape status symbol will flash. A tape without an erasure tab will be ejected. To correct this, load a tape with its erasure tab intact, and turn off the VCR.

#### using the satellite receiver

Your VCR can turn your satellite receiver on and off when it is time for a programmed recording.

You can view satellite channels through your VCR when your VCR is off only if you connected your VCR and TV with an S-Video cable. If you used a standard video cable, you can only view satellite channels through your VCR when the VCR is on.

#### memory backup

If the VCR is without power for 30 minutes or less, it will retain the time and the programmed settings, provided the VCR has been plugged in for at least an hour beforehand. If the power is lost for more than 30 minutes, the time and the programmed settings will be lost.



Now that you've learned about the basic operation of your VCR, you're ready to discover its advanced features. You'll find information on:

- ◆ Using the Advanced Playback Controls
- ◆ Using the Advanced Recording Controls
- ◆ Searching Techniques
- ◆ Using the Active A/V Network Features
- ◆ Making a Copy of a Tape
- ◆ Using Child Lock

Before you use the advanced features, you should be familiar with all of the VCR's basic operations, including viewing a picture coming from your VCR (page 25), playing back a tape (page 27), using the menus (page 31), and recording (page 40). If you find any of the information in this section confusing, you may want to review the previous chapters.

---

## ◆ Using the Advanced Playback Controls

In this section, you'll discover some of the advanced playback features of your VCR. These include:

- Using special effects,
- Adjusting the tracking, and
- Using the time counter.

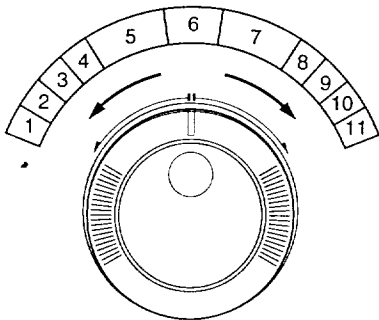

- 1 Reverse high speed search
- 2 Reverse speed search
- 3 Reverse fast playback
- 4 Reverse playback
- 5 Reverse slow-motion playback
- 6 Still
- 7 Slow-motion playback
- 8 Playback
- 9 Quickview
- 10 Forward speed search
- 11 Forward high speed search

### Using special effects

You can use the shuttle ring and the jog dial on the front panel, or the shuttle ring and ADJUST dial on the remote to control the playback speed of the tape.

#### using the shuttle ring when the tape is paused

Turning the shuttle ring will change the playback speed in steps.

- ❶ While the VCR is playing a tape, press the PAUSE button to freeze the picture on the screen.
- ❷ Turn the shuttle ring and hold it to play the tape at a particular speed (see the chart to the left). If you release the ring, it will come back to the center position, and the still (PAUSE) mode will resume.
- ❸ To resume normal playback, press the PLAY button.

► **Important:** After about five minutes in the still or slow-motion mode, the VCR will automatically stop to avoid damage to the tape. Depending on the type of TV you are using, the picture may vibrate vertically when you pause the VCR's picture.

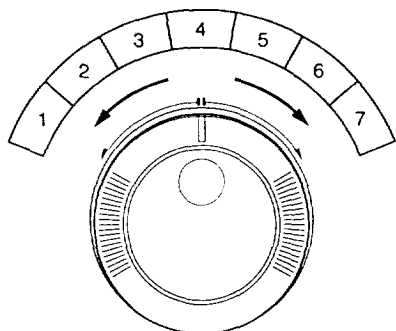

- 1 Reverse high speed search
- 2 Reverse speed search
- 3 Reverse fast playback
- 4 Playback
- 5 Quickview
- 6 Forward speed search
- 7 Forward high speed search

#### using the shuttle ring when the tape is playing

You can also change the playback speed with the shuttle ring without entering the PAUSE mode. To do this, turn the shuttle ring and hold it to play the tape at a particular speed (see the diagram to the left). If you release the ring, it will come back to the center position, and normal playback will resume.

#### using the jog dial or ADJUST dial

You can use the jog dial or the ADJUST dial to advance the tape frame by frame.

- ❶ While the VCR is playing a tape, press the PAUSE button to freeze the picture on the screen.
- ❷ Turn the jog dial or ADJUST dial clockwise to advance the tape forward. Turn it counter-clockwise to reverse the tape. The faster you turn the dial, the faster the tape will move.
- ❸ To resume normal playback, press the PLAY button.

#### jog/shuttle indicators

When you are using special effects, the jog/shuttle indicators (► and ◀) and the pause indicator (||) will light up as follows:

- || will light up when you are in still frame
- ► will light up when you use a special effect in the forward direction; ◀ will light up when you use a special effect in the reverse direction
- || and ► will light up when you move frame by frame forward. || and ◀ will light up when you move frame by frame in reverse.

#### using still adjustment

Sometimes during still frame, the picture may vibrate or shake. To correct this problem, turn the jog dial on the front panel while pressing the ONE KEY PROGRAM button. (Side-to-side vibration cannot be corrected.)

### Adjusting the tracking

#### automatic tracking

Your VCR automatically adjusts the tape to give you the best quality picture. When you press the PLAY button, the DIGITAL TRACKING light will flash, showing that the VCR is adjusting the picture. When the VCR has finished adjusting the picture, the DTR light will shine steadily.

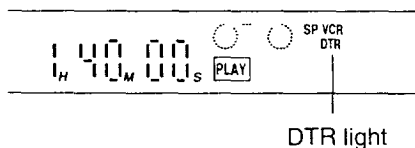

► **Important:** A certain amount of "noise" in the picture or sound is normal while the VCR is tracking a tape.



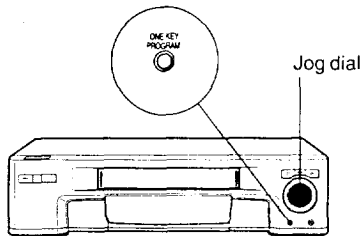

### manual tracking

From time to time, you might play a tape that has excess “noise” in the picture (often looking like vibration or interference at the top or bottom of the screen). To correct the picture, you will have to manually track the tape.

- ❶ While the tape is playing, press and hold the ONE KEY PROGRAM button and turn the jog dial until the picture is clear of excess “noise.”
- ❷ To continue automatic tracking, press the ONE KEY PROGRAM button on the front panel. Automatic tracking will also resume when you eject the tape.

### slow tracking

Slow tracking is used to adjust the playback quality during slow motion playback and still frame. You can only use slow tracking if your tape was recorded in extended play (EP) speed. To adjust the slow tracking, put a tape into slow motion, then press and hold the ONE KEY PROGRAM button and turn the jog dial on the front panel of the VCR until the best picture is obtained.

### Using the time counter

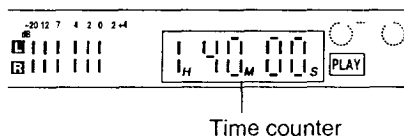

Your VCR has a time counter that shows the amount of time the tape has run in hours, minutes, and seconds. This counter is useful when you want to find specific points on a tape. The counter will not work with blank tapes, on blank sections of tape, or when the VCR's power is off.

### setting the counter

To set the counter to “0H00M00s,” press the CANCEL button on the remote control. (You cannot reset the counter if the VCR channel number is being displayed on the TV or if you are using the VCR's menus.)

Your VCR will automatically reset the counter to “0H00M00s” when you load a tape into the VCR. It will display “- H - - M - - S” when there is no tape in the VCR.

▷ **Important:** The counter cannot display times greater than “9H59M59s” in either the forward or reverse direction. If you are using a tape labeled T-210, the counter will not be displayed correctly when the tape runs longer than “9H59M59s.”

## ◆ Using the Advanced Recording Controls

In this section, you'll learn about some of the advanced recording features of your VCR, including:

- Using the PerfectTape™ feature,
- Displaying the time gauge and the remaining time, and
- Displaying the present time.

## Using the PerfectTape™ feature

PerfectTape™ is an exclusive Mitsubishi feature that tests the quality of your video tapes. After each test, the VCR will adjust its internal circuitry in order to make the best possible recording on your tape.

### setting up PerfectTape™

You have the option of setting PerfectTape™ to function only when you start a test, or to automatically function every time you insert a tape that has not yet been recorded. To do this:

- ❶ Press the MENU button on the remote control to display the “VCR Main Menu.” Use the ADJUST dial on the remote control to move the cursor next to “First Time Set-Up.” Turn the shuttle ring right.
- ❷ The “First Time Set-Up” menu will appear. Use the ADJUST dial to move the cursor next to “Customize choices” and turn the shuttle ring right.
- ❸ The “Customize choices” menu will appear. The cursor will be next to the “PerfectTape” option.
- ❹ Turn the shuttle ring right to set “PerfectTape” to AUTO or MANUAL.
- ❺ Press the MENU button three times to turn off the menus.

If you set PerfectTape™ to AUTO, the VCR will automatically test any non-recorded tapes you place in the VCR. It will not automatically test pre-recorded tapes – you must choose to test those yourself.

If you set PerfectTape™ to MANUAL, the VCR will not automatically test any tapes. PerfectTape will only function when you initiate a test.

### using PerfectTape™ automatically

Before you begin, you need to:

- have set “PerfectTape” to “AUTO” in the “Customize choices” menu.

- ❶ Load a tape that has not been recorded into the VCR.

The VCR will display the testing status screen. When testing, the VCR records for one second, then evaluates the recording it made. The entire test takes about eight seconds. During this time, the “PT” light on the front panel will flash. If you wish to cancel the test, press the STOP button while the “PT” light is still flashing.

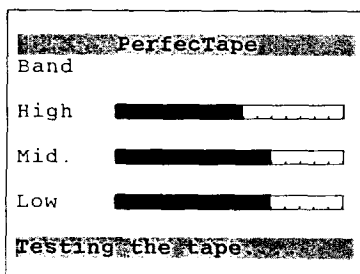
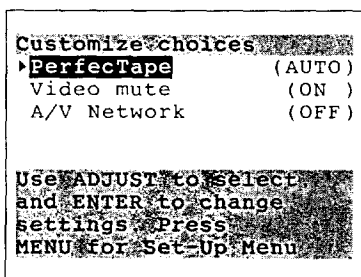
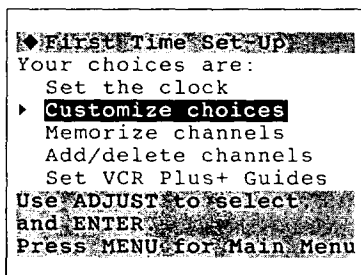

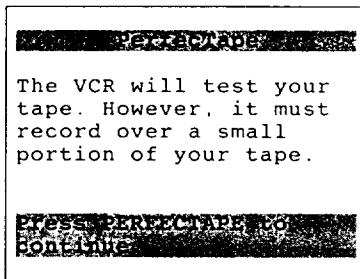
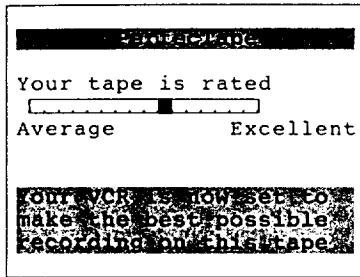

When the test is finished, the VCR will display the rating of your tape for eight seconds. On the front panel, the "PT" light will shine steadily, indicating that the VCR has set its internal circuitry to make the best possible recording on this tape.

#### using PerfectTape™ manually

- ❶ Load a tape that has its erasure tab intact into the VCR.
- ❷ Find a portion of the tape that is OK to record over; this feature will record over one second of your tape.
- ❸ Press the PERFECTAPE button on the front panel. You will see the PerfectTape™ explanation screen.
- ❹ Press the PERFECTAPE button again to begin the test. The VCR will display the testing status screen. When testing, the VCR records for one second, then evaluates the recording it made. The test takes about eight seconds. During this time, the "PT" light on the front panel will flash. To cancel the test, press the STOP button while the "PT" light is still flashing.

When the test is finished, the VCR will display the rating of your tape for eight seconds. On the front panel, the "PT" light will shine steadily, indicating that the VCR has set its internal circuitry to make the best recording on the tape. You can quickly turn off the display by pressing the STOP button or the PERFECTAPE button.

If you would like to record without the settings that resulted from the test, press the PERFECTAPE button to turn off the PT light on the fluorescent display. If you would like to restore the settings, press the PERFECTAPE button to turn the PT light back on. Should you wish to erase the settings, eject the tape. The settings will also be erased if you press the TIMER RESET button or if the VCR loses power.

#### Displaying the time gauge and the remaining time

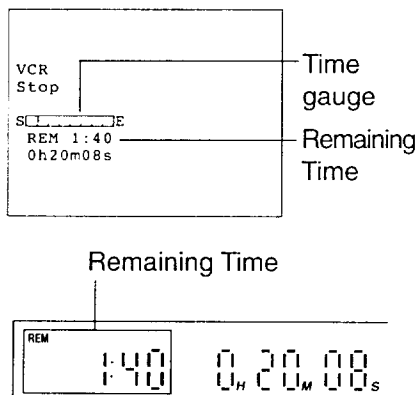

The time gauge is a graphic representation of your position on a video tape. The left side of the gauge is the start (S) of the tape, and the right side is the end (E) of the tape. For a T-120 length tape, played at standard (SP) speed, each mark on the gauge represents about 15 minutes. The remaining time display shows the time, in hours and minutes, left until the end of a tape.

#### The time gauge and the remaining time automatically appear:

during fast forward and rewind (from a stopped tape), during timed searches, index searches, when rewinding for repeat playback, during skip search, and during searches for blank sections of tape.

You can turn off the time gauge and the remaining time by pressing the DISPLAY button twice.

**To make the time gauge and the remaining time appear:**

Press the DISPLAY button once. The time gauge and remaining time will appear on the TV screen, and the remaining time will appear on the fluorescent display. They will disappear after four seconds when playing a tape. To turn off the display, press the DISPLAY button twice.

- ▷ **Important:** The time gauge and remaining time work by detecting control signals on recorded tapes. They will therefore not function with tapes that have not yet been recorded. Also, you must have set the "Tape" video function correctly.

Depending on the length of the tape being used, it may take a moment for the display to appear.

The tape remaining display may not show the correct remaining time if the tape function is incorrectly set (see "Using the Audio and Video Functions" on page 28), if you are using speed search, if you are using a special length cassette (such as T-10 length or T-210 length), or if you are using a cassette with an adapter.

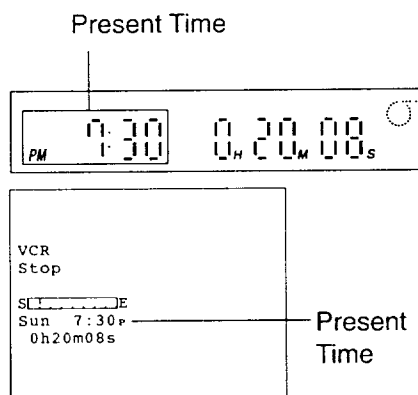
**Displaying the present time**

The present time display on the fluorescent display panel or on the TV screen shows the current time. If you have not set the clock, or if there has been a power failure of longer than 30 minutes, the display will show - : - -. The current time will be displayed when the VCR is off. To see the current time when the VCR is on:

- ① Press the DISPLAY button on the remote control twice. The peak level meter will be replaced by the present time.
- ② To turn off the present time, press DISPLAY once.

**◆ Searching Techniques**

The VCR lets you search through a tape in a number of ways. These include:

- Quick searching,
- Edit searching,
- Speed searching,
- Searching by time,
- Searching for a blank portion of tape, and
- Index search techniques.

**Quick searching**

This feature lets you search through the tape you are playing in 30 second intervals. It is designed so that you can quickly speed through any commercials you may have recorded.

"..." indicates 30 seconds of quick search time

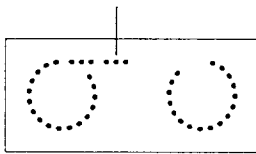

- 1 While playing a tape, press the Q.V. button. The VCR will speed through 30 seconds of tape, then resume playback.
- 2 Press the Q.V. button again for an additional 30 second interval of quick search. You can press Q.V. up to 4 times, for a quick search total of 2 minutes. The quick search time is indicated on the fluorescent display.

### Edit searching

Edit search is very useful for editing out commercials if you are recording a program while you are watching it. It is also useful as a general editing feature. This feature is sometimes called EE (electronic-to-electronic) editing. This function works only when you are in "record-pause" mode.

- 1 During record pause, press the FF or REW button or use the shuttle ring to locate the point where you want to resume recording.
- 2 When you find the point where you want to continue recording (e.g. the last frame before the commercial), stop operating the buttons or shuttle ring. After 3 seconds, the VCR will return to record pause; you will see the live picture.
- 3 Press the PAUSE button (NOT the REC button) to resume recording (when the commercials are over).

▷ **Important:** Edit search will begin any time you are in record-pause and operate the REW or FF buttons or the shuttle ring. Edit search will end after 3 seconds of not using the buttons or shuttle ring.

### Speed searching

You can use speed search to visually search through the contents of a videotape. To do this:

- 1 While playing a tape, press FF or REW button on the remote control. You will see the picture as it fast forwards or rewinds. It is normal to see some "noise bars."
- 2 If you press the FF or REW button and hold it down for about 1 second, the search speed will increase.
- 3 To resume normal playback, press FF or REW again quickly, or press PLAY.

▷ **Important:** The fastest search speed that allows you to see the picture is about 30 times normal speed. Using fast forward or rewind without the picture allows you to search up to 200 times normal speed. The fastest way to move through the tape is without a picture. It is normal for the number of noise bars on the screen to increase and roll from top to bottom as the visual search speed increases.

**spot check**

This feature allows you to visually check the position of the tape during fast forward or rewind.

- ❶ While the tape is in fast forward or rewind (without picture), press and hold either the FF or REW button (whichever is the same as what the tape is doing).
- ❷ After a short delay, you will see the contents of the videotape, still in speed search. The picture will stay on the screen as long as you hold down the button.
- ❸ When you release the button, the tape will resume fast forwarding or rewinding without a picture.

**Searching by time**

You can use the time counter to search to a specific point on a tape. You can search in one of two ways:

- You can search to a certain point, measured from the beginning of the tape.
- You can search to a certain point, measured from the current position on the tape. (You cannot search further than “9h59m59s” in either direction.)

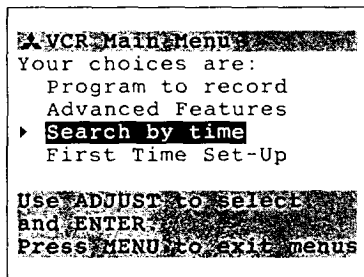

To search for a point measured from the beginning of the tape:

- ❶ Press the MENU button on the remote control to display the “VCR Main Menu.”
- ❷ Turn the ADJUST dial on the remote control to move the cursor next to “Search by time.” Turn the shuttle ring right.

▷ **Important:** If there is no tape loaded in the VCR, or if the VCR is recording, then the words “Not available” will flash and you will see an error message. Load a tape into the VCR or stop recording.

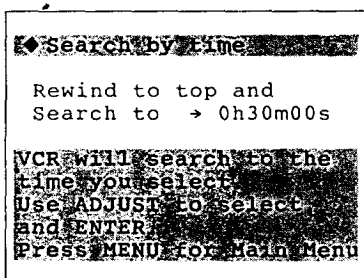

- ❸ You will see the “Search by time” menu. Turn the ADJUST dial to set the point on the tape (measured from the beginning) to which you want to search, in hours and minutes.

Turn the ADJUST dial quickly to set the hour and minutes in 10-minute intervals. Turn it slowly to set single minutes. You can also use the number buttons.

If you want to clear the time you have entered, press CANCEL or turn the shuttle ring left.

▷ **Important:** If the elapsed time counter has been reset, the display you will see will not match the one shown in step ❸. If this is the case, eject the tape and reinsert it, then repeat steps ❶ through ❸.

- 4 Turn the shuttle ring right. (If you used the number buttons, you do not need to do this.) The VCR will rewind to the beginning of the tape, reset the counter to 0h00m00s, fast forward to the point you selected and begin playing.
- 5 Press PLAY or STOP to cancel the time search.

To search to a point, measured from the current tape position:

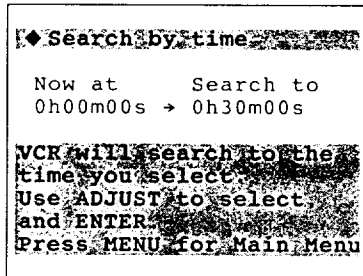

- 1 Before entering the menus, press the CANCEL button to reset the counter to 0h00m00s.
- 2 Follow the instructions 1 through 3 above. You will see the display at the left.
- 3 Turn the shuttle ring right. The VCR will fast forward or rewind to the point you select.

If you want to search to another point on the same tape, you do not need to press the CANCEL button in step 1.

▷ **Important:** If the VCR reaches the end of the tape before finding the point you've chosen, the search is canceled; if the VCR reaches the beginning of the tape, it will begin playback. The tape may not search to the exact point you have chosen.

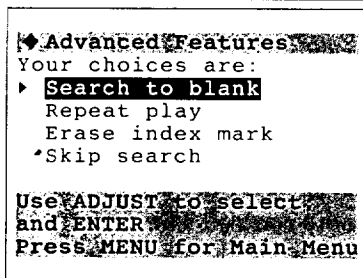
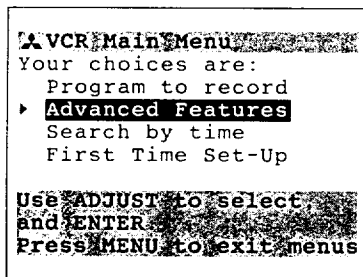

### Searching for a blank portion of tape

Use "Search to blank" to find the next blank portion of a tape.

- 1 Press the MENU button on the remote control to display the "VCR Main Menu."
- 2 Turn the ADJUST dial on the remote control to move the cursor next to "Advanced Features." Turn the shuttle ring right. ("Advanced Features" are not available if there is no tape in the VCR, or if the VCR is recording.)
- 3 The "Advanced Features" menu will appear on your screen. The cursor will be next to "Search to blank." Turn the shuttle ring right. The VCR will fast forward and stop at the first blank (unrecorded) section of tape. If the VCR reaches the end of the tape, the search is canceled.

▷ **Important:** If there is no tape loaded in the VCR, or if the VCR is recording, you will see an error message, indicating that this feature is not available. Load a tape into the VCR or stop recording.

### Index search techniques

Index search is a way to find specific points on a tape. Before using index search, index marks are placed at important places on a tape. Then, index search is used to find these marks. Index marks are added automatically whenever your VCR starts a new recording; you can also add index marks manually at any point.

### automatic index marks

Whenever recording is begun from the STOP mode, an index mark is automatically added to the tape. The index light (▼) will flash on the fluorescent display, and an on-screen message will indicate that the mark is being recorded.

- ▷ **Important:** Index marks are not added when you press PAUSE to begin recording from the record-pause mode.

### manual index marks

To add an index mark yourself, press the REC button on the remote control while a tape is recording or playing.

- ▷ **Important:** Index marks must be added at least one minute apart. You cannot add an index mark to a tape with its erasure tab removed. When you add an index mark to a playing tape, the sound on the mono track will turn off. To search for an index mark:

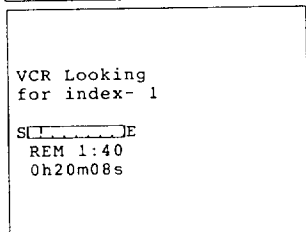
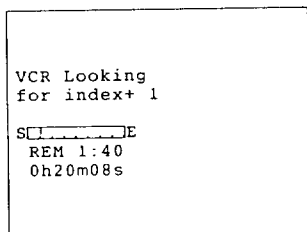

- 1 Press the INDEX SEARCH “+” button on the remote control to begin a forward search; press INDEX SEARCH “-” to search in the reverse direction. The VCR will fast forward or rewind and display one of two screens (left) on the TV.

Once the VCR finds an index mark, it will begin playing back the tape from that point.

- 2 You can press the plus (+) or minus (-) buttons up to 19 times to search for that many index marks. For example, to find the third index mark ahead, press the plus (+) button three times. The on-screen display will count down the number of marks to be passed before playback begins.
- 3 To cancel index search, press PLAY or STOP.

### erasing index marks

- 1 Make sure the video mute function is on. (See “Using Video Mute” on page 36.)
- 2 Press the MENU button on the remote control. The “VCR Main Menu” will appear on your screen.
- 3 Use the ADJUST dial on the remote control to move the cursor next to “Advanced Features.” Turn the shuttle ring right. (“Advanced Features” are not available if there is no tape in the VCR, or if the VCR is recording.)
- 4 The “Advanced Features” menu will appear on your screen. Turn the ADJUST dial to move the cursor next to “Erase index mark.” Then, turn the shuttle ring right.

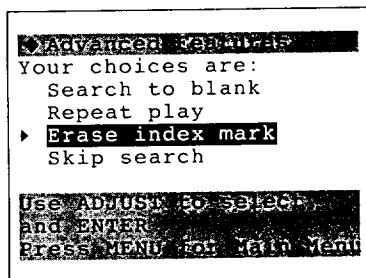



▷ **Important:** If there is no tape loaded in the VCR, if the VCR is recording, or if the tape has had its erasure tab removed, you will see an error message indicating that this feature is not available. Load a tape into the VCR, stop recording, or place a piece of tape over the erasure tab to correct this.

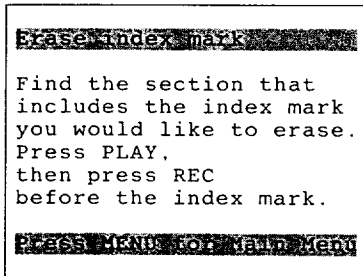

- 5 You will see the “Erase Index Mark” menu (left). Without exiting the menus, use the INDEX SEARCH buttons to find the index mark you wish to erase.
- 6 When the index mark has been located, and playback has begun, press STOP.
- 7 Rewind the tape for a few seconds, then press STOP.
- 8 Press the PLAY button, then the REC button on the remote control. The index light (▼) on the fluorescent display will light up. When the index mark is found, the index light (▼) on the fluorescent display will flash, and the mark will be erased.
- 9 When the index mark has been erased, press STOP.

▷ **Important:** When you erase an index mark from a tape, you cannot hear the sound on the mono track.

#### using repeat playback

You can play back a section of tape over and over using the following procedure. The tape will play until the next index mark, rewind to the previous index mark, and resume playing. If there is only one index mark on the tape, then the VCR will play or rewind to that mark and resume playback. If there is no index mark, the entire cassette will repeat.

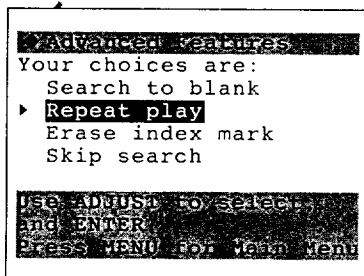
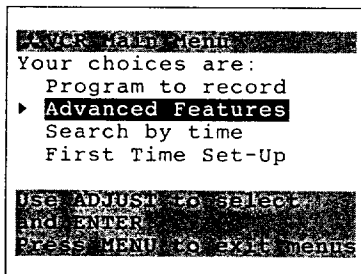

- 1 Press the MENU button on the remote control. The “VCR Main Menu” will appear on your screen. Use the ADJUST dial to place the cursor next to “Advanced Features.” Turn the shuttle ring right.
- 2 The “Advanced Features” menu will appear on the screen. Use the ADJUST dial on the remote control to move the cursor next to “Repeat play.” Turn the shuttle ring right.

When the VCR encounters the next mark (or the end of the tape), it will automatically rewind to the previous mark and begin playback.

▷ **Important:** If there is no tape loaded in the VCR, or if the VCR is recording, you will see an error message indicating that this feature is not available. Load a tape into the VCR or stop recording.

- 3 Press the STOP button to cancel the repeat.

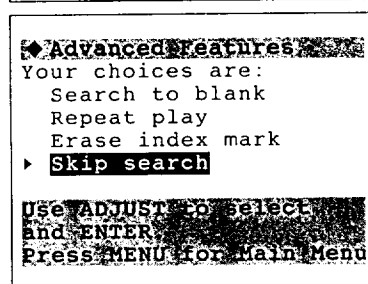
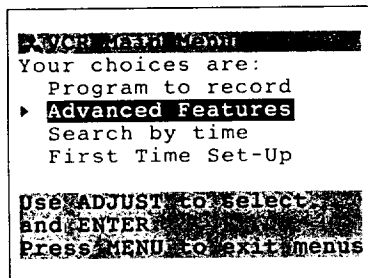

### skip search

When you use skip search, the VCR will fast forward or rewind (without picture) through the tape, showing you short sections of the tape wherever it finds an index mark. Skip search only works if there are index marks recorded on the tape.

- ❶ Press the MENU button on the remote control. The “VCR Main Menu” will appear on your screen. Use the ADJUST dial to move the cursor next to “Advanced Features.” Turn the shuttle ring right.
- ❷ The “Advanced Features” menu will appear on the screen. Use the ADJUST buttons on the remote control to move the cursor next to “Skip search.” Turn the shuttle ring right.

The VCR will fast forward until it finds an index mark. Then, it will show the tape in visual forward speed search for about five seconds. Then it will fast forward again, looking for the next index mark.

▷ **Important:** If there is no tape loaded in the VCR, or if the VCR is recording, you will see an error message indicating that this feature is not available. Load a tape into the VCR or stop recording.

- ❸ Press PLAY when you see the section you are looking for.
- ❹ Press REW to reverse the direction of the skip search.
- ❺ Press STOP or PLAY to cancel skip search.

▷ **Important:** When searching forward, skip search will only find index marks recorded more than three minutes apart; when searching in reverse, skip search will only find index marks recorded at least ten minutes apart.

## ◆ Using the Active A/V Network Features

The Active A/V Network is a benefit of certain Mitsubishi TVs and VCRs. The Active A/V Network allows you to use many of the commonly used features of your system at the press of one button.

### Before you begin,

- your VCR must be connected to External 1 (EXT-1) of a Mitsubishi TV with Active A/V Network; (pages 15-17)
- you must have turned on video mute (page 36);
- you must have turned on the Active A/V Network setting on your TV (see your TV's owner's guide for information);
- you must have set the VCR remote mode to VCR-A; and
- you must have connected a cable from the Active A/V Network OUT terminal of the TV to the Active A/V Network IN terminal of the VCR (page 19).

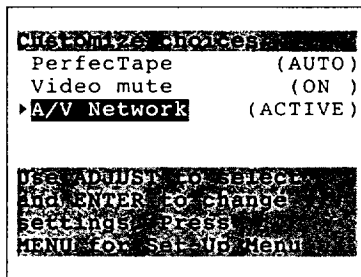
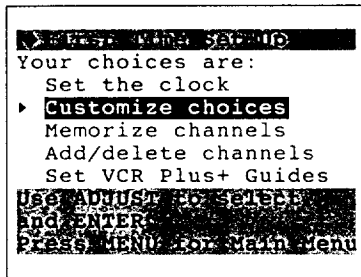

To turn on the Active A/V Network on your VCR:

- ❶ Press the MENU button on the remote control. The “VCR Main Menu” appears on your TV.
- ❷ Use the ADJUST dial on the remote to move the cursor next to “First Time Set-Up.” Turn the shuttle ring right.
- ❸ The “First Time Set-Up” menu appears on your screen. Use the ADJUST dial to move the cursor next to “Customize choices.” Turn the shuttle ring right.
- ❹ Use the ADJUST dial to move the cursor next to “A/V Network.”
- ❺ Turn the shuttle ring right to set “A/V Network” to ACTIVE.
- ❻ Press the MENU button three times to turn off the menus.

#### what the Active A/V Network does

The Active A/V Network makes it easier and faster to use the VCR’s Quick Program and Play commands.

#### When you press QUICK PROGRAM/VCR Plus+ to begin programming:

- Active A/V Network will turn on your VCR and bring it to the VCR Plus+ “Program to Record” Screen.
- Active A/V Network will turn on your TV (if it is off), and switch the TV to EXT-1.

#### When you press QUICK PROGRAM/VCR Plus+ to end programming:

- Active A/V Network will turn off your VCR (unless a tape is currently playing or recording).
- Active A/V Network will return your TV to the channel it was on before, or turn it off (if it was off originally).

#### When you press PLAY on the remote:

- Active A/V Network will turn your VCR on and begin playing the tape.
- Active A/V Network will turn the TV on, set to EXT-1.

#### When you turn your TV off:

- Your VCR will turn off, unless it is playing or recording.

Active A/V Network also affects your VCR when your TV’s P.I.P. function is used. Active A/V Network can set your VCR’s clock if your TV is equipped with the “StarSight” feature. See your TV Owner’s Guide for more information.

▷ **Important:** When using the Active A/V Network, you should always point your remote control at your television, not at your VCR.

## ◆ Making a Copy of a Tape

There are two basic ways to make a copy of a tape. One way is to use the HS-U760 to play a tape and use another VCR to record. The other way is to use another VCR to play a tape and the HS-U760 to record.

Whichever method you choose, you will need one RCA audio cable and one RCA video cable (or one S-Video cable) to connect the two VCRs. If you do not have these cables, they are available at your local electronics retailer. In this section you'll learn:

- Using your HS-U760 to record from another VCR,
- Using your HS-U760 to play back to another VCR, and
- Using edit control.

### Using your HS-U760 to record from another VCR

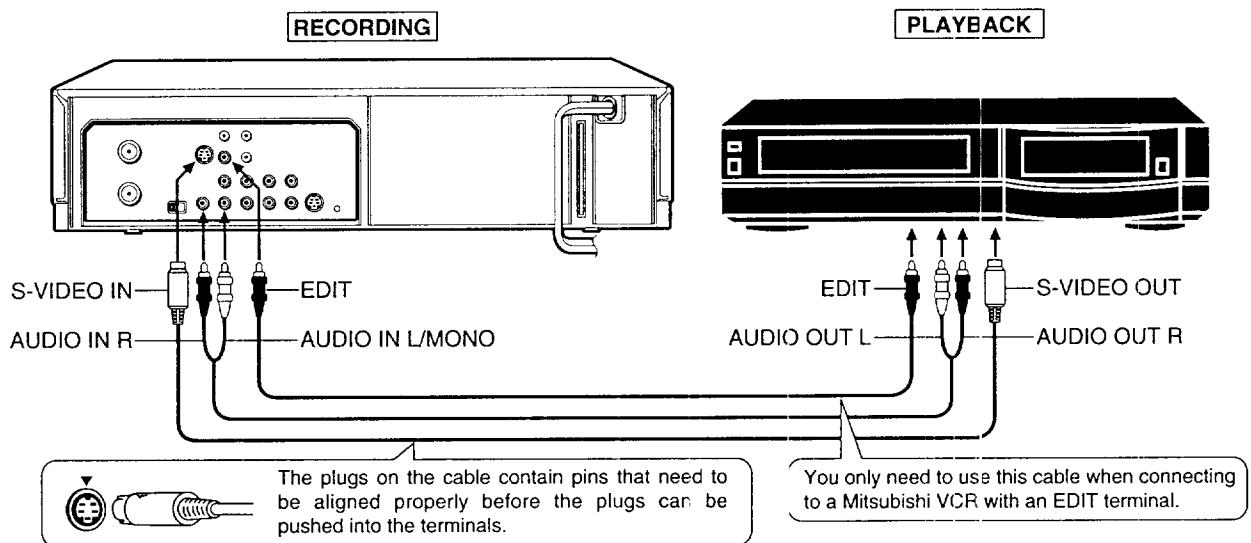

- 1 Connect one RCA audio cable to the AUDIO OUTPUT terminal on the other VCR. Connect the other end of this cable to the AUDIO INPUT terminal on the HS-U760 labeled L/MONO. If the other VCR is mono, this is the only audio connection necessary.
- 2 If the other VCR has stereo outputs, connect another RCA audio cable to the AUDIO OUTPUT terminal of the playback VCR. Connect the other end of this cable to the AUDIO INPUT terminal on the HS-U760 (labeled R).
- 3 If you are recording from a standard VHS VCR, connect a video cable to the VIDEO OUTPUT terminal on the playback VCR. Connect the other end of this cable to the VIDEO INPUT terminal on the HS-U760 (labeled VIDEO IN). If you are dubbing from an S-VHS VCR, connect an S-Video cable to the S-VIDEO OUTPUT terminal on the playback VCR. Connect the other end of this cable to the S-VIDEO INPUT terminal on the HS-U760 (labeled S-VIDEO IN).
- 4 If you want to record from a standard video source connected to the HS-U760's rear panel, you must disconnect any S-Video cables (such as those from a satellite receiver.)
- 4 If you are using another Mitsubishi VCR with an EDIT terminal, connect a cable between the two VCR's EDIT terminals.
- 5 If the other VCR is a Hi-Fi deck, set the audio monitor to "STEREO."

- 6 If you attached the connection cables to the back of the HS-U760, use the INPUT button to set the HS-U760 to External 1 (L1). If you attached the cables to the front of the HS-U760, use the INPUT button to set the HS-U760 to External 2 (L2).
- 7 If you connected the EDIT terminals, see "Using edit control" later in this chapter.
- 8 Put a blank tape into the HS-U760 and find where you want to begin recording. Press STOP. If you are recording in S-VHS, you should use an S-VHS tape and set the recording format to S-VHS.
- 9 Put the tape you want to copy into the other VCR and find the place from which you want to begin copying. Press STOP.
- 10 On the HS-U760, press REC, then PAUSE.
- 11 On the other VCR, press PLAY, then PAUSE.
- 12 Release the PAUSE button on both VCRs at the same time.
- 12 When finished, press STOP on both VCRs.

### Using your HS-U760 to play back to another VCR

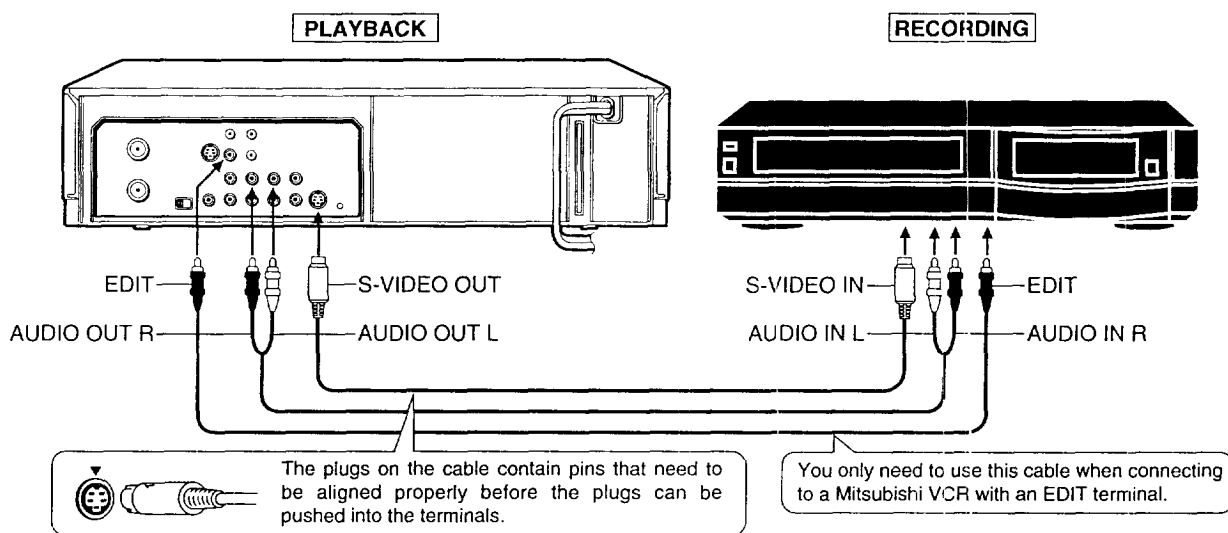

- 1 Connect one RCA audio cable to the AUDIO INPUT terminal on the other VCR. Connect the other end of this cable to the AUDIO OUTPUT terminal on the HS-U760 (labeled L). If the other VCR is mono, you need a Y-adaptor to record both audio channels.
- 2 If the other VCR has stereo outputs, connect another RCA audio cable to the AUDIO INPUT terminal of the other VCR. Connect the other end of this cable to the AUDIO OUTPUT terminal on the HS-U760 (R).
- 3 If you are dubbing to a standard VCR, connect a video cable to the VIDEO INPUT terminal on the other VCR. Connect the other end of this cable to the VIDEO OUTPUT terminal on the HS-U760 (VIDEO OUT).
- 4 If you are using another Mitsubishi VCR with an EDIT jack, you can connect the two VCRs for synchronized editing. This makes editing much easier and requires only one additional video cable for connection. Connect the cable between the EDIT jacks on the both VCRs.
- 5 Set the audio monitor on the HS-U760 to "STEREO." (See "Selecting and adjusting the audio and video functions," on page 29.)

- ⑥ Set the I.P. switch on your HS-U760 to "DUB." This turns off the sharpness control and improves the quality of your copy. In addition, the on-screen displays will not appear, so they won't be accidentally copied onto your new tape. Make sure to set the I.P. switch to ON or NORMAL when you're done.
- ⑦ Set the input of the other VCR to "External."
- ⑧ If you connected the EDIT jack, see "Using edit control" later in this chapter to make the copy.
- ⑨ Put a blank tape into the other VCR and find the place where you want to begin recording. Press STOP. If the other VCR is a Super VHS VCR, be sure to use an S-VHS tape, and to set the recording format to S-VHS.
- ⑩ Put the tape you want to copy into the HS-U760 and find the place from which you want to begin copying. Press STOP.
- ⑪ On the other VCR, press record (REC), and then PAUSE.
- ⑫ On the HS-U760, press PLAY and then PAUSE.
- ⑬ Release the PAUSE button on both VCRs at the same time.
- ⑭ Press STOP on both VCRs when you are finished.

### Using edit control

If the other VCR you are using is a Mitsubishi VCR with an EDIT jack, you can synchronize the starting and stopping of the VCRs when editing. This greatly simplifies editing, and requires only the additional connection of an edit cable between the two VCRs.

Connect the two VCRs as described in the previous section (Using your HS-U760 to play back to another VCR), and follow the instructions in the table at the top of the next page.

HS-U760 (Playback VCR)	Other Mitsubishi VCR with an EDIT jack (Recording VCR)
Locate the start of the scene you want to copy and press PAUSE.	Locate the point where you want recording to begin, press PAUSE, then RECORD.
Press the PLAY button. Your HS-U760 automatically rewinds a short way and then begins to play back. (This function, called "preroll," allows the HS-U760 to get up to speed before the edit begins, resulting in cleaner edits.)	Once PLAY is pressed on the HS-U760, recording will automatically begin on this VCR.
Press the PAUSE button when you want to stop the edit.	This VCR will automatically PAUSE.
You may use the ADJUST dial, the shuttle ring, or the jog dial to find the next edit point. When you have located the edit point, press PLAY.	This VCR will begin recording.

## ◆ Using Child Lock

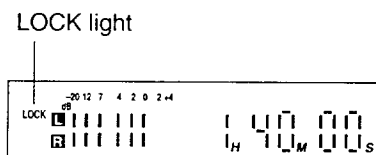

The child lock feature prevents others from using your VCR. To lock the VCR:

- ① Press and hold down the DISPLAY button on the remote control for about 8 seconds. The LOCK light on the fluorescent display will light up.
- ② To cancel the child lock, press and hold down the DISPLAY button for about 8 seconds, until the LOCK light on the fluorescent display goes out.

▷ **Important:** You can lock the VCR with the power off, even if the VCR is standing by for a programmed recording. If you lock the VCR with no cassette in it, the VCR will not accept a cassette.



## CHAPTER FIVE Troubleshooting

Problems	Possible Solutions	For More Information
The VCR won't turn on.	<ul style="list-style-type: none"><li>• Check the power cord and the AC outlet.</li><li>• Is the LOCK light ON? If so, press and hold the DISPLAY button for more than 8 seconds until the LOCK light disappears.</li></ul>	See Chapter 1, "Getting to Know Your VCR."
The VCR power is on but no controls work.	<ul style="list-style-type: none"><li>• Press the TIMER RESET button.</li><li>• Is the LOCK light ON? If so, press and hold the DISPLAY button for more than 8 seconds until the LOCK light disappears.</li></ul>	See Chapter 3, "Operating Your VCR."
You can't see the VCR's picture on your TV.	<ul style="list-style-type: none"><li>• Check the TV's input setting.</li><li>• Check to see that your VCR is not set to "L1" or "L2."</li></ul>	See Chapter 3, "Operating Your VCR."
Poor picture when watching the VCR's tuner on your TV.	<ul style="list-style-type: none"><li>• Check the VIDEO CHANNEL setting on the back of your VCR.</li><li>• Check your TV's fine tuning.</li></ul>	See Chapter 3, "Operating Your VCR."
VCR REC button doesn't function.	<ul style="list-style-type: none"><li>• Check the erasure prevention tab on the cassette.</li></ul>	See Chapter 3, "Operating Your VCR."
No picture during recording.	<ul style="list-style-type: none"><li>• Check the hook-up.</li><li>• Check to see if your TV is set to the correct channel or input.</li></ul>	See Chapter 2, "Connecting Your VCR" or Chapter 3, "Operating Your VCR."
VCR does not record TV.	<ul style="list-style-type: none"><li>• Check the VCR tuning.</li><li>• Check the input selection on the VCR. Does the front panel display show "L1" or "L2"? If so, you must switch it to tuner by pressing the INPUT button.</li></ul>	See Chapter 3, "Operating Your VCR."
The VCR timer recording does not operate.	<ul style="list-style-type: none"><li>• Check that the programmed recording light lights up on the fluorescent display.</li><li>• Check the clock time.</li></ul>	See Chapter 3, "Operating Your VCR."
Noise in the picture and distorted sound.	<ul style="list-style-type: none"><li>• Check the tracking control. Adjust manually if necessary.</li></ul>	See Chapter 4, "Using the Advanced Features."
Poor or no Hi-Fi sound.	<ul style="list-style-type: none"><li>• Check the monitor settings.</li><li>• Check the quality of the video tape.</li></ul>	See Chapter 3, "Operating Your VCR."
Playback is noisy or "snowy".	<ul style="list-style-type: none"><li>• Try automatic head cleaning.</li><li>• Have your VCR video heads cleaned by a qualified service technician.</li></ul>	See Chapter 3, "Operating Your VCR."
VCR remote does not function.	<ul style="list-style-type: none"><li>• Press the VCR button on the remote control before operating your VCR.</li><li>• Press the TV button on the remote control before operating your TV.</li></ul>	See Chapter 3, "Operating Your VCR."
Your converter box or satellite receiver does not respond to any signals from the VCR's Remote Control Transmitter (the small window on top of the VCR).	<ul style="list-style-type: none"><li>• Try moving the cable box so that there is a clear line of sight between the transmitter and the box's remote sensor.</li><li>• Sometimes a cable box needs to be set by the cable company to receive signals. Contact your cable company.</li><li>• You may need to connect a cable (part number, "KIT-CBC" to the CONVERTER BOX CONTROL terminal on the rear of the VCR. Contact your Mitsubishi dealer for more help.</li></ul>	



**A**

A/V Network:  
 active ..... 64  
 connecting ..... 19  
 terminals ..... 11  
 adding channels ..... 36  
 adjust dial ..... 9  
 antenna  
 connecting ..... 12  
 terminals ..... 11  
 audio  
 connecting a TV with  
 inputs ..... 17  
 function button ..... 10  
 input terminals ..... 6, 11  
 monitor ..... 29  
 using functions ..... 28  
 auto speed programming .... 50

**B**

backup, memory ..... 52  
 batteries  
 installing ..... 22  
 blank, searching for ..... 61

**C**

cable box  
 code numbers ..... 34  
 connecting ..... 13  
 cable tuning light ..... 8  
 cable, connecting ..... 12  
 cancel button ..... 10  
 canceling programmed recording ..... 52  
 cassette slot ..... 6  
 changing programmed  
 settings ..... 51  
 changing settings while  
 programming ..... 44, 49  
 channel buttons ..... 9  
 channel display ..... 8  
 channels  
 adding and deleting ..... 36  
 programming the VCR to  
 receive ..... 33  
 selecting ..... 37  
 VCR Plus+ guides ..... 38  
 child lock ..... 69  
 cleaning, head ..... 26  
 clock, setting ..... 31

Connecting Your VCR ..... 12

connecting  
 A/V Network ..... 19  
 antenna ..... 12  
 cable ..... 12  
 cable box ..... 13  
 satellite ..... 18  
 television ..... 15, 16, 17  
 UHF/VHF antennas ..... 14  
 converter box  
 control terminal ..... 11  
 transmitter ..... 6  
 copying a tape ..... 66  
 counter display ..... 7  
 counter, time ..... 55

**D**

daylight savings time ..... 32  
 deleting channels ..... 36  
 digital tracking (DTR) light .. 8  
 display button ..... 10  
 dubbing ..... 66

**E**

edit search ..... 59  
 eject button ..... 6, 9  
 enter button ..... 11  
 erasure, preventing tape .... 26

**F**

fast forward button ..... 10  
 fast forwarding ..... 27  
 features, advanced ..... 53  
 fluorescent display ..... 6, 7  
 français ..... 23  
 Front Panel Buttons and  
 Functions ..... 6  
 front display ..... 30

**G**

guides, VCR Plus+  
 channel ..... 38

**H**

head cleaning ..... 26

**I**

Important Safeguards ..... 2

**index**

light ..... 8  
 marks ..... 62  
 search ..... 61  
 search buttons ..... 9  
 input  
 audio terminal ..... 6, 11  
 button ..... 6, 9  
 video terminals ..... 6, 11  
 installing the batteries ..... 22  
 intelligent picture ..... 31

**J**

jog dial ..... 7

**L**

L+R ..... 30  
 language, selecting ..... 28  
 level meters ..... 30  
 loading tapes ..... 26  
 lock light ..... 7  
 lock, child ..... 69

**M**

memorizing channels ..... 33  
 memory backup ..... 52  
 menu button ..... 9  
 menus, using ..... 31  
 mode buttons ..... 10  
 monitor television ..... 22  
 mono ..... 30  
 mute button ..... 9  
 mute, video ..... 36

**N**

normal recording ..... 30  
 number buttons ..... 10

**O**

OFF-T button ..... 10  
 one key program button ..... 7  
 one key programming ..... 47  
 one-touch recording (OTR)  
 button ..... 7, 10  
 using ..... 46

**P**

pause button ..... 7, 10  
 pausing a tape ..... 27

- PerfectTape  
   button ..... 7  
   light ..... 8  
   using ..... 56  
 picture-in-picture (PIP)  
   buttons ..... 10  
 picture, viewing the one  
   coming from your VCR .... 25  
 PIP source button ..... 10  
 play button ..... 6, 10  
 play light ..... 8  
 playback controls ..... 27  
   advanced ..... 53  
 power button ..... 6, 9  
 programmed recording light . 8  
 programming  
   auto speed ..... 50  
   changing settings  
     while ..... 44, 49  
   one key ..... 47  
   the VCR to receive  
     channels ..... 33  
   TV shows that end the day  
     after ..... 51  
   VCR Plus+ ..... 44  
   VCR to record ..... 41
- Q**
- quick program  
   button ..... 10  
   using ..... 45  
 quick search ..... 58  
 quick view button ..... 9  
 quick view, super ..... 37
- R**
- record button ..... 7, 9  
 recording format ..... 30  
 record light ..... 8  
 recording speed ..... 30  
 recording  
   advanced controls ..... 55  
   canceling ..... 52  
   changing programmed  
     settings ..... 51  
   current broadcast ..... 40  
   notes about ..... 50  
   one key programming ..... 47  
   one-touch ..... 46  
   programming your  
     VCR to ..... 41  
     Quick Program ..... 45  
     VCR Plus+ ..... 44  
 remain light ..... 7
- remaining time ..... 57  
 remote control  
   buttons ..... 9  
   installing batteries ..... 22  
   overview ..... 9  
   sensor ..... 6  
   switch ..... 6  
   using ..... 22  
 repaired tapes ..... 26  
 repeat playback ..... 63  
 rewind button ..... 9  
 rewinding ..... 27
- S**
- safeguards, important ..... 2  
 SAP ..... 30  
 SAP indicator ..... 8  
 satellite  
   channel display ..... 8  
   connecting ..... 18  
   memorizing channels ..... 33  
   programming to record .... 42  
 search  
   blank ..... 61  
   edit ..... 59  
   index ..... 61  
   quick ..... 58  
   skip ..... 64  
   speed ..... 59  
   techniques ..... 58  
   time ..... 60  
 setting the clock ..... 31  
 sharpness ..... 31  
 shuttle ring ..... 6, 10  
 skip search ..... 64  
 skipping programs ..... 51  
 slow motion ..... 53  
 special effects ..... 53  
 speed search ..... 59  
 spot check ..... 60  
 stereo ..... 30  
 stereo indicator ..... 8  
 stop button ..... 6, 9  
 super quick view ..... 37
- T**
- tape speed light ..... 8  
 tape status symbol ..... 7  
 tape  
   copying ..... 66  
   function ..... 31  
   loading ..... 26  
   playing ..... 27  
   preventing erasure ..... 26
- repaired ..... 26  
 repeating ..... 63  
 searching for blank ..... 61  
 unloading ..... 26  
 television  
   connecting ..... 15  
   monitor ..... 22  
   operating with remote .... 23  
 terminals, rear panel ..... 11  
 time counter ..... 55  
 time, setting ..... 31  
 time  
   gauge ..... 57  
   present ..... 58  
   remaining ..... 57  
   search ..... 60  
 timer reset button ..... 11, 52  
 tracking ..... 54  
 TV button ..... 9
- U**
- UHF/VHF antennas,  
   connecting ..... 14  
 unloading tapes ..... 26
- V**
- VCR Plus+  
   button ..... 10  
   programming with ..... 44  
   setting channel guides .... 38  
 VCR-A/VCR-B button ..... 10  
 VCR/TV button ..... 10  
 VCR  
   A/B remote control switch . 6  
   button ..... 9  
   light ..... 8  
   locking ..... 69  
   operating ..... 21  
   operating two with one  
     remote ..... 23  
   operating with remote .... 22  
   setting up ..... 21  
   viewing the picture coming  
     from your ..... 25  
 vibration, controlling ..... 28  
 video channel switch .... 11, 21  
 video  
   connecting a TV with  
     inputs ..... 16  
   function button ..... 11  
   input terminals ..... 6, 11  
   mute ..... 36  
   using functions ..... 28  
 volume controls ..... 9

## MITSUBISHI VIDEO CASSETTE RECORDER LIMITED WARRANTY

MITSUBISHI ELECTRONICS AMERICA, INC. ("MELA") warrants to the original purchaser of this video cassette recorder if purchased from an authorized MITSUBISHI Audio/Video Dealer that, should it prove defective by reason of improper workmanship and/or material:

- a. **Parts.** For one year from the date of original purchase at retail, we will repair or replace, at our option, any defective part including the video head without charge for the part. Parts used for replacement are warranted for the remainder of the original warranty period.
- b. **Labor.** For six months from the date of original purchase at retail, we will provide the labor for a warranty repair without charge at an authorized MITSUBISHI service center.
- c. **Notice.** To obtain warranty service, you must notify an authorized MITSUBISHI service center of any defect within the applicable warranty time period.

1. **TO OBTAIN WARRANTY SERVICE,** deliver your VCR to the nearest MITSUBISHI service center. Shipping expenses are your responsibility. The name and address of the nearest service center can be obtained from your MITSUBISHI Dealer, or by writing or calling MELA at the address and telephone number below. Proof of purchase date from an authorized MITSUBISHI Dealer is required when requesting warranty service. Present your sales receipt or other document which establishes proof and date of purchase. **THE RETURN OF THE OWNER REGISTRATION CARD IS NOT A CONDITION OF WARRANTY COVERAGE.** However, please detach and return the Owner Registration Card so that we can contact you should a question of safety arise which could affect you.

2. **THIS WARRANTY DOES NOT COVER** damage caused by: modification, alteration, repair or service of this product by anyone other than an authorized MITSUBISHI service center; physical abuse to, or misuse of, the VCR; operation in a manner contrary to the instructions which accompany the VCR; freight damage; or any damage caused by acts of God such as lightning or fluctuation in electrical power. This warranty also excludes all costs arising from installation, adjustment of user controls, external antenna systems, service of products purchased or serviced outside the U.S.A., initial technical adjustments (set-up) and user-required maintenance including head cleaning. Consult the operating instructions enclosed with the product for information regarding user controls.

3. **ANY EXPRESS WARRANTY NOT PROVIDED HEREIN, AND ANY REMEDY WHICH, BUT FOR THIS PROVISION, MIGHT ARISE BY IMPLICATION OR OPERATION OF LAW, IS HEREBY EXCLUDED AND DISCLAIMED. THE IMPLIED WARRANTIES OF MERCHANTABILITY AND OF FITNESS FOR ANY PARTICULAR PURPOSE ARE EXPRESSLY LIMITED TO A TERM OF ONE YEAR.**

4. **UNDER NO CIRCUMSTANCES SHALL MELA BE LIABLE TO PURCHASER OR ANY OTHER PERSON FOR ANY INCIDENTAL, SPECIAL OR CONSEQUENTIAL DAMAGES, WHETHER ARISING OUT OF BREACH OF WARRANTY, BREACH OF CONTRACT, OR OTHERWISE.**

5. Some state do not allow limitations on how long an implied warranty lasts, or the exclusion or limitation of incidental, special, or consequential damages, so the above limitations or exclusions may not apply to you.

6. This warranty gives you specific legal rights and you may also have other rights which vary from state to state.

7. **BEFORE REQUESTING SERVICE,** please review the instruction booklet to insure proper installation and correct customer control adjustment. If the problem persists, contact your nearest MITSUBISHI Dealer for name(s) of authorized MITSUBISHI Service Center(s). If you are unable to obtain the information, please call 1-800-332-2119, or write us at the address below.

**MITSUBISHI ELECTRONICS AMERICA, INC.**  
P.O. Box 5025  
Norcross, GA 30091-5025



RETAIN THIS PORTION FOR YOUR RECORDS

SERIAL NO. \_\_\_\_\_

CUSTOMER NAME _____			
STREET ADDRESS _____			
CITY _____	STATE _____	ZIP _____	
PHONE (    ) _____	PURCHASE DATE _____ / _____ / _____		
	MO	DAY	YR

PLACE OF PURCHASE \_\_\_\_\_



MITSUBISHI ELECTRONICS AMERICA, INC.  
6100 Atlantic Boulevard  
Norcross, GA 30071-1305

© 1995 Mitsubishi Electronics America, Inc.

872C137A3

PRINTED IN JAPAN