

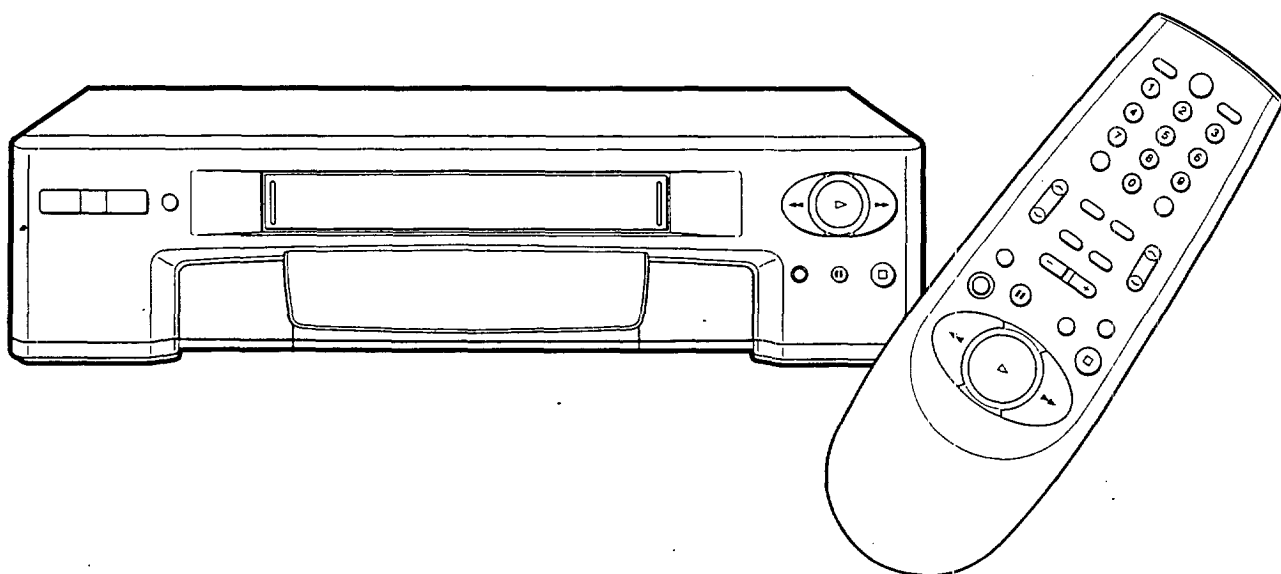

 MITSUBISHI

HS-U510

Video
Cassette
Recorder
Owner's
Guide



 This Video Cassette Recorder is based on the VHS format. Only video cassette tapes with the  mark may be used with this model.

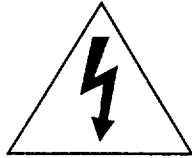

CAUTION

RISK OF ELECTRIC SHOCK
DO NOT OPEN



CAUTION: TO REDUCE THE RISK OF ELECTRIC SHOCK,
DO NOT REMOVE COVER (OR BACK)
NO USER-SERVICABLE PARTS INSIDE
REFER SERVICING TO QUALIFIED SERVICE PERSONNEL.

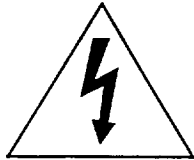

The lightning flash with arrowhead symbol, within an equilateral triangle, is intended to alert the user to the presence of uninsulated “dangerous voltage” within the product’s enclosure that may be of sufficient magnitude to constitute a risk of electric shock.



The exclamation point within an equilateral triangle is intended to alert the user to the presence of important operating and maintenance (servicing) instructions in the literature accompanying the appliance.

IMPORTANT:

RECORDING OF COPYRIGHTED TELEVISION PROGRAMS MAY VIOLATE COPYRIGHT LAW.

WARNING:

TO PREVENT FIRE OR SHOCK HAZARD, DO NOT EXPOSE THIS APPLIANCE TO RAIN OR MOISTURE.

CAUTION:

TO PREVENT ELECTRIC SHOCK HAZARD, DO NOT USE THIS (POLARIZED) PLUG WITH AN EXTENSION CORD, RECEPTACLE OR OTHER OUTLET UNLESS THE BLADES CAN BE FULLY INSERTED TO PREVENT BLADE EXPOSURE.

NOTE TO CATV SYSTEM INSTALLER:

THIS REMINDER IS PROVIDED TO CALL THE CATV SYSTEM INSTALLER’S ATTENTION TO ARTICLE 820-40 OF THE NEC THAT PROVIDES GUIDELINES FOR PROPER GROUNDING AND, IN PARTICULAR, SPECIFIES THAT THE CABLE GROUND SHALL BE CONNECTED TO THE GROUNDING SYSTEM OF THE BUILDING, AS CLOSE TO THE POINT OF CABLE ENTRY AS PRACTICAL.



Table of Contents

Important Safeguards	2
Preface	
Welcome to Mitsubishi	5
Unpacking Your VCR	5
Chapter One	
Getting to Know Your VCR	6
Front Panel Buttons and Functions	6
Fluorescent Display	7
Overview of the Remote Control	8
Rear Panel Terminals	10
Chapter Two	
Connecting Your VCR	11
Connecting the Antenna or Cable to the VCR	11
Connecting cable antennas	11
Connecting other antennas	13
Connecting separate UHF/VHF antennas	14
Connecting the Television	15
Determining if you need a splitter	15
Connecting a regular TV to the VCR	16
Connecting a TV with audio and video inputs	16
Connecting the A/V Network (optional)	17
Chapter Three	
Operating Your VCR	19
Setting Up Your VCR for the First Time ..	19
Setting up your VCR if you are using a regular TV	19
Setting up your VCR if you are using a monitor TV	20
Using the Remote Control	20
Using the remote control to operate the VCR	20
Using the remote control to operate the TV	21
Viewing the Picture Coming from Your VCR	22
Viewing the picture coming from your VCR if you are using a regular TV	23
Viewing the picture coming from your VCR if you are using a monitor TV	23
Loading and Unloading Tapes	23
Playing a Tape	24
Playing back a tape	24
Using basic playback controls	25
Selecting the On-screen Language	25
Using the Audio and Video Functions	26
Selecting and adjusting the audio and video functions	26
Descriptions of audio and video functions	27
Using the Menus to Set the Time	28
Programming the VCR to Receive TV Channels	30
Programming channels automatically ..	30
Using video mute	31
Adding and deleting channels	32
Selecting a channel	33
Recording	33
Recording a current broadcast	34
Programming your VCR to record	35
Using One-Touch Recording (OTR)	37
Using One Key Programming	38
Using Quick Program	40
Notes about programmed recording	41
Chapter Four	
Using the Advanced Features	45
Using the Advanced Playback Controls ..	45
Using special effects	45
Adjusting the tracking	46
Using the time counter	47
Using the Advanced Recording Controls ..	47
Using the PerfectTape™ feature	48
Displaying the time gauge and the remaining time	49
Displaying the present time	50
Searching Techniques	50
Edit searching	51
Speed searching	51
Searching by time	52
Searching for a blank portion of tape ..	53
Index search techniques	53
Using the Active A/V Network Features ..	56
Making a Copy of a Tape	57
Using your HS-U510 to record from another VCR	58
Using your HS-U510 to play back to another VCR	59
Using Child Lock	59
Chapter Five	
Troubleshooting	60
Index	61

IMPORTANT SAFEGUARDS

PLEASE READ ALL THESE INSTRUCTIONS REGARDING YOUR VCR AND RETAIN FOR FUTURE REFERENCE. FOLLOW ALL WARNINGS AND INSTRUCTIONS MARKED ON THE VCR.

1. Read Instructions

All the safety and operating instructions should be read before the appliance is operated.

2. Retain Instructions

The safety and operating instructions should be retained for future reference.

3. Heed Warnings

All warnings on the appliance and in the operating instructions should be adhered to.

4. Follow instructions

All operating and use instructions should be followed.

5. Cleaning

Unplug this video product from the wall outlet before cleaning. Do not use liquid cleaners or aerosol cleaners. Use a damp cloth for cleaning.

6. Attachments

Do not use attachments not recommended by the video product manufacturer as they may cause hazards.

7. Water and Moisture

Do not use this video product near water — for example, near a bath tub, wash bowl, kitchen sink, or laundry tub, in a wet basement, or near a swimming pool, and the like.

8. Accessories

Do not place this video product on an unstable cart, stand, tripod, bracket, or table. The video product may fall, causing serious injury to a child or adult, and serious damage to the appliance. Use only with a cart, stand, tripod, bracket, or table recommended by the manufacturer, or sold with the video product. Any mounting of the appliance should follow the manufacturer's instructions, and should use a mounting accessory recommended by the manufacturer.

An appliance and cart combination should be moved with care. Quick stops, excessive force, and uneven surfaces may cause the appliance and cart combination to overturn.



9. Ventilation

Slots and openings in the cabinet are provided for ventilation and to ensure reliable operation of the video product and to protect it from overheating, and these openings must not be blocked or covered. The openings should never be blocked by placing the video product on a bed, sofa, rug, or other similar surface. This video product should never be placed near or over a radiator or heat register. This video product should not be placed in a built-in installation such as a bookcase or rack unless proper ventilation is provided or the manufacturer's instructions have been adhered to.

10. Power Sources

This video product should be operated only from the type of power source indicated on the marking label. If you are not sure of the type of power supply to your home, consult your appliance dealer or local power company. For video products intended to operate from battery power, or other sources, refer to the operating instructions.

11. Grounding or Polarization

This video product is equipped with a polarized alternating-current line plug (a plug having one blade wider than the other). This plug will fit into the power outlet only one way. This is a safety feature. If you are unable to insert the plug fully into the outlet, try reversing the plug. If the plug should still fail to fit, contact your electrician to replace your obsolete outlet. Do not defeat the safety purpose of the polarized plug.

12. Power-Cord Protection

Power-supply cords should be routed so that they are not likely to be walked on or pinched by items placed upon or against them, paying particular attention to cords at plugs, convenience receptacles, and the point where they exit from the appliance.

13. Lightning

For added protection for this video product receiver during a lightning storm, or when it is left unattended and unused for long periods of time, unplug it from the wall outlet and disconnect the antenna or cable system. This will prevent damage to the video product due to lightning and power-line surges.

14. Power Lines

An outside antenna system should not be located in the vicinity of overhead power lines or other electric light or power circuits, or where it can fall into such power lines or circuits. When installing an outside antenna system, extreme care should be taken to keep from touching such power lines or circuits as contact with them might be fatal.

15. Overloading

Do not overload wall outlets and extension cords as this can result in a risk of fire or electric shock.

16. Object and Liquid Entry

Never push objects of any kind into this video product through openings as they may touch dangerous voltage points or short-out parts that could result in a fire or electric shock. Never spill liquid of any kind on the video product.

17. Outdoor Antenna Grounding

If an outside antenna or cable system is connected to the video product, be sure the antenna or cable system is grounded so as to provide some protection against voltage surges and built-up static charges.

Section 810 of the National Electrical Code, ANSI/NFPA No. 70, provides information with regard to proper grounding of the mast and supporting structure, grounding of the lead-in wire to an antenna discharge unit, size of grounding conductors, location of antenna discharge unit, connection to grounding electrodes, and requirements for the grounding electrode.

EXAMPLE OF ANTENNA GROUNDING

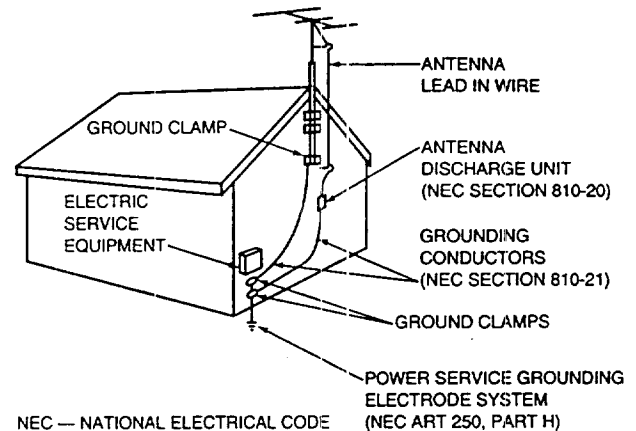

18. Servicing

Do not attempt to service this video product yourself as opening or removing covers may expose you to dangerous voltage or other hazards. Refer all servicing to qualified service personnel.

19. Damage Requiring Service

Unplug this video product from the wall outlet and refer servicing to qualified service personnel under the following conditions:

- When the power-supply cord or plug is damaged.
- If liquid has been spilled, or objects have fallen into the video product.
- If the video product has been exposed to rain or water.
- If the video product does not operate normally by following the operating instructions.
Adjust only those controls that are covered by the operating instructions as an improper adjustment of other controls may result in damage and will often require extensive work by a qualified technician to restore the video product to its normal operation.
- If the video product has been dropped or the cabinet has been damaged.
- When the video product exhibits a distinct change in performance — this indicates a need for service.

20. Replacement Parts

When replacement parts are required, be sure the service technician has used replacement parts specified by the manufacturer or have the same characteristics as the original part. Unauthorized substitutions may result in fire, electric shock or other hazards.

21. Safety Check

Upon completion of any service or repairs to this video product, ask the service technician to perform safety checks to determine that the video product is in safe operating conditions.

CONDENSATION

Leave the VCR on, without a tape in it, for 2 hours if the VCR has been exposed to sudden changes in temperature. Sudden temperature changes cause moisture to form on the metal parts inside the VCR. This moisture can cause tape to stick and damage the head. Leaving the VCR on for a 2 hour period will dry the inside of the VCR.

PROTECT THE POWER CORD

Do not damage the power cord. Damage to the power cord may cause a fire or shock hazard. When unplugging the power cord, please hold by the plug and remove it carefully.

DO NOT PLACE ANYTHING ON THE RECORDER

Heavy objects placed on the recorder will cause damage. The top of the recorder is also slotted to provide ventilation. Do not obstruct these ventilation slots.

WHEN NOT IN USE

When you finish operating the recorder, always unload the cassette and turn OFF the VCR POWER.

CARE OF THE VIDEO CASSETTE TAPES

- Avoid violent vibration or shock.
- Do not place in a location where strong magnetic fields exist (near a motor, transformer or magnet).
- Never place or store in direct sunlight.
- Avoid dusty places.
- Place the cassette in the cassette case and store vertically.
- Never store tape in a high humidity location.

INFORMATION

This equipment has been tested and found to comply with the limits for a Class B digital device, pursuant to Part 15 of the FCC Rules. These limits are designed to provide reasonable protection against harmful interference in a residential installation. This equipment generates, uses, and can radiate radio frequency energy and, if not installed and used in accordance with the instructions, may cause harmful interference to radio communications. However, there is no guarantee that interference will not occur in a particular installation. If this equipment does cause harmful interference to radio or television reception, which can be determined by turning the equipment off and on, the user is encouraged to try to correct the interference by one or more of the following measures:

- Reorient or relocate the receiving antenna;
- Increase the separation between the equipment and receiver;
- Connect the equipment into an outlet on a circuit different from that to which the receiver is connected;
- Consult the dealer or an experienced radio/TV technician for help.

Changes or modifications not expressly approved by the party responsible for compliance could void the user's authority to operate the equipment.

If necessary, the user should consult the dealer or an experienced radio/television technician for additional suggestions. The user may find the following booklet prepared by the Federal Communications Commission helpful:

"How to Identify and Resolve Radio-TV Interference Problems."

This booklet is available from the US Government Printing Office, Washington, D.C., 20402, Stock No. 004-000-00345-4.



Congratulations on your purchase of this Mitsubishi Video Cassette Recorder. Your new VCR produces superior sound and a high resolution VHS picture. It includes VHS Hi-Fi audio recording and playback, delivering compact disc-quality audio.

Your owner's guide has been designed with easy-to-follow explanations and directions. In addition, your VCR comes with Mitsubishi's exclusive **VIEWPOINT**® on-screen operating system. This system has been developed to simplify the operation of your VCR with clear, understandable language and design.

Thank you for selecting our product and welcome to Mitsubishi.

◆ Unpacking Your VCR

As you unpack your new VCR, please make sure the following items are included:

- Remote control

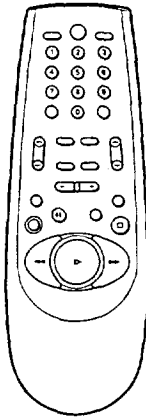

- 2 "AA" size batteries



- Registration card

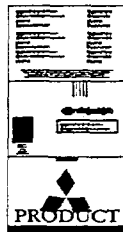

- 1 Audio cable with red and white plugs at each end

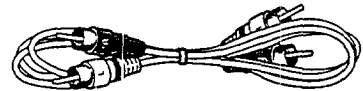

- 1 Video cable

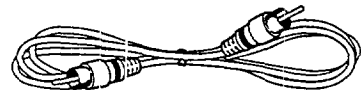

- 1 Coaxial cable

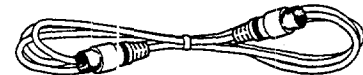

If any of these items are missing, please contact your dealer.

A few suggestions:

- ① Be sure to save the box and packing material your VCR came in. Your VCR should always be transported in this box.
- ② Before you hook up your VCR, please take a few minutes to:
 - complete the registration card and send it back to us immediately,
 - file your sales receipt in a safe place, and
 - place the VCR on a stable surface with sufficient lighting to do the hook-up.

▷ **Important:** Never place any heavy objects on top of the VCR. Do not place the VCR on top of the television.



Now that you have unpacked your player and read through the safety information, it's time to become familiar with the buttons and controls.

If you are experienced with using VCRs, you may just want to glance at this section and refer to it later. If VCRs are new to you, you may want to take your time and become familiar with the locations of all the controls.

On the following pages, you'll find information on:

- ◆ **Front Panel Buttons and Functions**
- ◆ **Fluorescent Display**
- ◆ **Overview of the Remote Control**
- ◆ **Rear Panel Terminals**

◆ **Front Panel Buttons and Functions**

- ① **power button (POWER)**
Press this button to turn the VCR on or off. Remember, you need to turn the VCR off after you have programmed the VCR to record.
- ② **eject button (EJECT)**
Press this button to eject the cassette.
- ③ **PerfectTape button (PERFECTAPE)**
Press this button to use the PerfectTape™ feature. The PerfectTape™ feature will test your videotape and set the VCR to make the best possible recording with that tape.
- ④ **cassette slot**
This is where you put the video cassette.
- ⑤ **rewind and reverse search button (REW)**
Press this button to rewind a tape or to reverse search. You can also use this button to control the playback speed of a tape.
- ⑥ **play button (PLAY)**
Press this button to play a tape.
- ⑦ **fast forward and fast forward search button (FF)**
Press this button to fast forward a tape or to fast forward search. You can also use this button to control the playback speed of a tape.
- ⑧ **video input 2 terminal**
If you want to record a video signal from another source (such as a camcorder or VCR), you connect the other source here.
- ⑨ **audio input 2 terminals**
If you want to record an audio signal from another source (such as a camcorder or VCR), you connect the other source here.
- ⑩ **input button (INPUT)**
Press this button to choose between the antenna and any other equipment that may be connected. You will also use this button to adjust the VCR's clock for daylight savings time.
- ⑪ **remote control sensor**
This receives signals from the remote control. Do not block it.

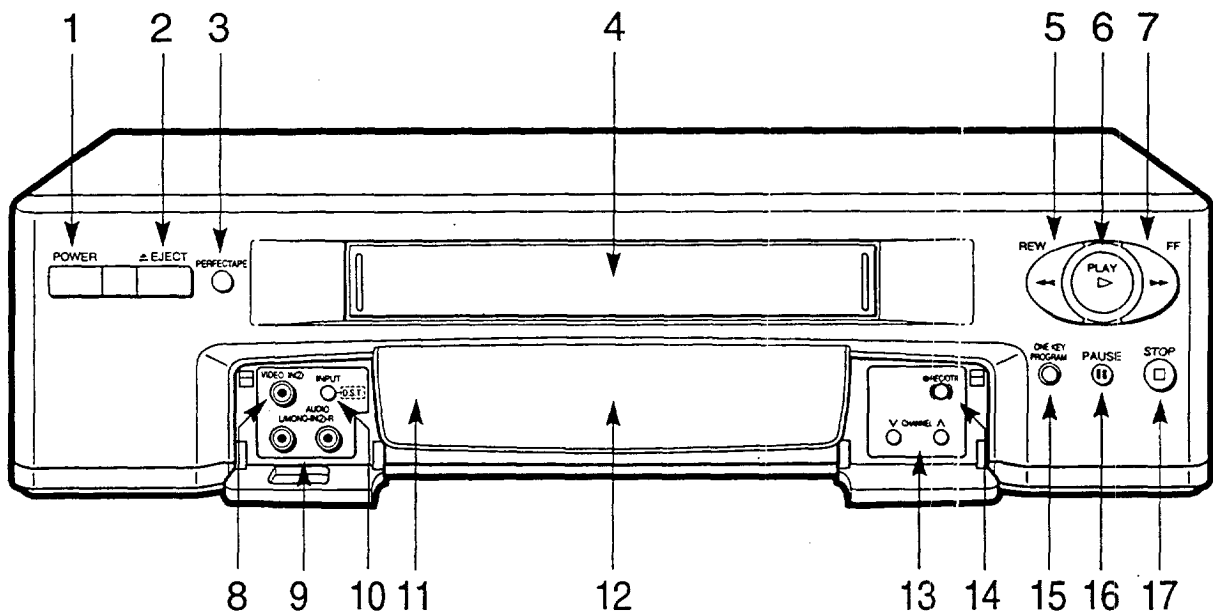

⑫ **fluorescent display**
See below.

⑬ **channel buttons (CHANNEL)**
Press these buttons to change channels. Also use these buttons to adjust tracking and picture vibration.

⑭ **record button (REC/OTR)**
Press this button once to record until the end of the tape. Press repeatedly to set the time for One-Touch Recording (OTR).

⑮ **one key program button (ONE KEY PROGRAM)**
Press this button to program the VCR to record.

⑯ **pause button (PAUSE)**
Press this button to pause a tape when recording, or to freeze a frame when viewing a tape.

⑰ **stop button (STOP)**
Press this button to stop a tape.

◆ **Fluorescent Display**
(see the illustration on the next page)

① **lock light (LOCK)**
This lights up when you use the "Child Lock" feature.

② **remain light (REM)**
When this is lit, the numbers in the display show the tape remaining on the tape, in hours and minutes.

③ **counter display**
This displays either the current time, how long the tape has run, or the amount of time remaining on the tape. The counter is automatically set to 0h00m00s when a new tape is loaded. It will display "-H -M -s" when no tape is in the VCR. The current time is displayed whenever the VCR is

turned off or when you press the DISPLAY button. This area also displays the contents of a programmed recording when you are programming your VCR. Additionally, it displays the audio level in decibels for both the left (L) and right (R) audio channels.

④ **tape status symbol**
This will light up when a tape is in the VCR. The dashes in the center of the symbol simulate the movement of the tape when playing and recording.

⑤ **programmed recording light**
This lights up when the VCR is off and you have programmed the VCR to record.

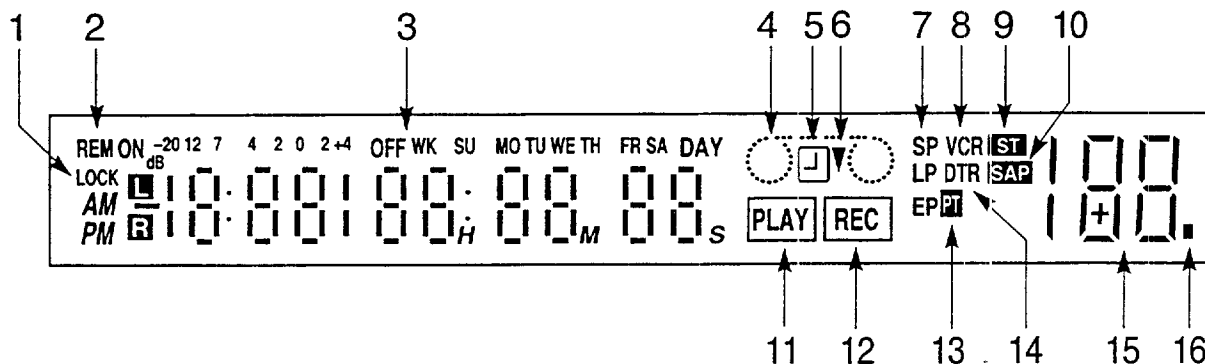

- ⑥ **index light**
This will flash when you are writing or erasing an index mark; it will light when you begin searching for an index mark.
- ⑦ **tape speed light (SP, LP, EP)**
This will light to indicate the tape speed you are using when playing or recording. "SP" indicates standard play; "LP" indicates long play; "EP" indicates extended play.
- ⑧ **VCR light (VCR)**
This will light up when the VCR/TV button is set to "VCR." It indicates that the antenna signal is being routed through the VCR's tuner.
- ⑨ **stereo indicator (ST)**
This lights up when the VCR is receiving a stereo signal.
- ⑩ **SAP indicator (SAP)**
This will light up to indicate that the channel you are watching has a Separate Audio Program, or SAP. An SAP is an alternative soundtrack to the program you are watching, often another language.
- ⑪ **play light (PLAY)**
This lights up when the VCR is playing.
- ⑫ **record light (REC)**
This lights up when the VCR is recording.
- ⑬ **PerfectTape light (PT)**
This will flash when the PerfectTape™ test is in progress. It will light steadily when the test is completed.
- ⑭ **digital tracking light (DTR)**
This will flash when you first play a new cassette, indicating that the VCR is adjusting the tracking. When tracking is finished, it will glow steadily. If you adjust the tracking manually, it will turn off.
- ⑮ **channel display**
This displays the channel or the input you have selected.
- ⑯ **cable tuning light**
This lights up when your VCR is set to receive cable broadcasts.

◆ Overview of the Remote Control

- ① **power button (POWER)**
Press this button to turn the VCR on or off. If you have programmed the VCR to record, you need to turn the VCR off.
- ② **TV button (TV)**
Your VCR remote control can be used to control most of the functions of many brands of televisions. After setting up your remote for your particular brand of television, press this button when you want to use the remote to operate your television. See your TV owner's guide for information about operating your TV.
- ③ **number buttons**
Use these buttons to select television stations.
- ④ **input button (INPUT)**
Press this button to select between the antenna and any other video equipment that may be connected.

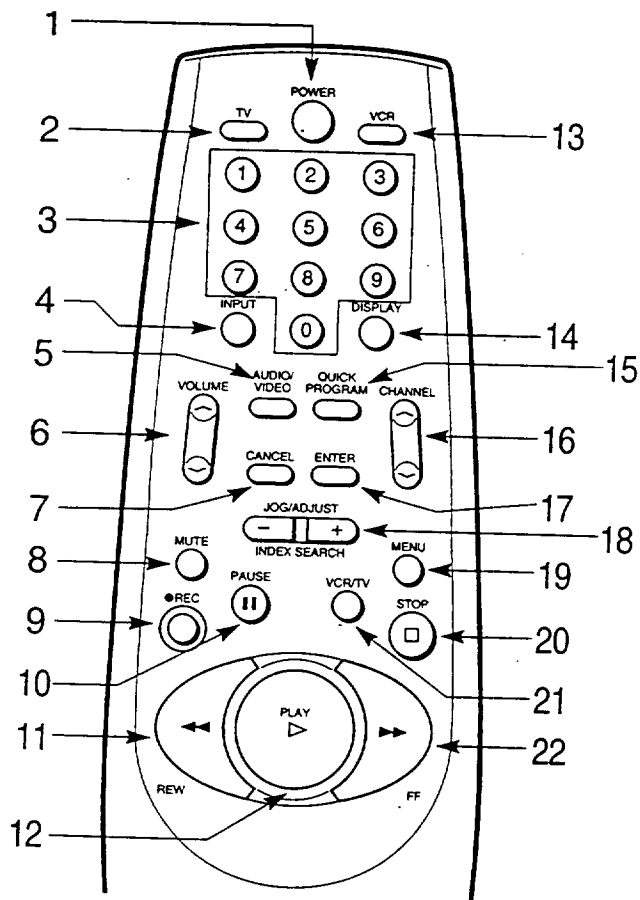

- ⑤ **function button (AUDIO/VIDEO)**
Press this button to adjust the VCR's audio and video functions.
- ⑥ **volume controls (VOLUME)**
Press the bottom half of this button (indicated by the down arrow) to lower the volume; press the top half of this button (the up arrow) to raise the volume.
- ⑦ **cancel button (CANCEL)**
Use this button to cancel selections on the on-screen menus or to reset the counter display to "0H00M00s."
- ⑧ **mute button (MUTE)**
Press this button to turn off the sound or to restore it to its previous volume.
- ⑨ **record button (REC)**
Press this button to start recording.
- ⑩ **pause button (PAUSE)**
Press this button to pause a tape when recording, or to freeze a frame when viewing a tape.
- ⑪ **rewind and reverse search button (REW)**
Press this button to rewind a tape or to reverse search. You can also use this button to control the playback speed of a tape.
- ⑫ **play button (PLAY)**
Press this button to play a tape.
- ⑬ **VCR button (VCR)**
Press this button before using the remote to operate your VCR.
- ⑭ **display button (DISPLAY)**
Press to display the following information on the television:
- how much time has elapsed on the current tape,
 - the channel number you are watching,
 - the source that is supplying the VCR with a signal,
 - the present time,
 - whether the VCR is stopped, playing, or recording, and
 - how much time is left on the tape.
- This button can also be used to turn on and off the "Child Lock" feature.
- ⑮ **quick program button (QUICK PROGRAM)**
This button allows you to program your VCR more quickly and easily. When you press this button, you will immediately see the "Program to record" screen, where you can begin programming your VCR to record.
- ⑯ **channel buttons (CHANNEL)**
Press these buttons to change channels.
- ⑰ **enter button (ENTER)**
Use this button to enter a channel or to enter selections on the on-screen menus.
- ⑱ **jog, adjust, and index search buttons (JOG/ADJUST, INDEX SEARCH)**
After pausing a tape, you can use these buttons to advance a tape frame-by-frame. When using the on-screen menus, use these buttons to select or adjust items. Otherwise, use these buttons to begin an index search.

- ⑱ **menu button (MENU)**
Press this button to display the menus, which are lists of features and instructions, on your television screen. Also press the button to exit the menus.
- ⑳ **stop button (STOP)**
Press this button to stop a tape.
- ㉑ **VCR/TV button (VCR/TV)**
Press this button to switch between the VCR's tuner and the TV's tuner. When

you select "VCR," you change channels on the VCR; when you select "TV," you change channels on the TV.

- ㉒ **fast forward and fast forward search button (FF)**
Press this button to fast forward a tape or to fast forward search. You can also use this button to control the playback speed of a tape.

◆ Rear Panel Terminals

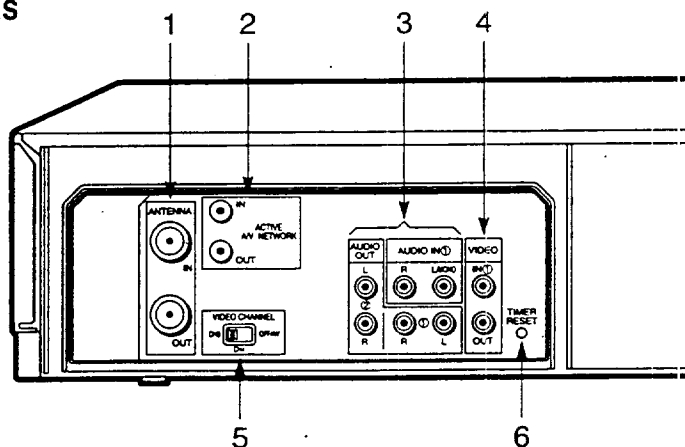

- ① **antenna terminals**
- **antenna in terminal (ANTENNA IN)**
Use this terminal to attach an external antenna or cable. This "brings in" an outside signal.
 - **antenna out terminal (ANTENNA OUT)**
Use this terminal to attach the VCR to your TV. This terminal "sends out" the signal to your TV.
- ② **A/V Network terminals (ACTIVE A/V NETWORK)**
Use these terminals to connect the VCR with other Mitsubishi products that have Active A/V Network terminals or A/V Network terminals.
- ③ **audio input and output terminals**
These red and white terminals are for sending (OUT) and receiving (IN) audio signals. Red signifies the right channel, and white signifies the left channel. Stereo audio cables are also color coded red and white. If you are receiving or sending a mono (not stereo) signal, you should use only the left (white) terminal.
- ④ **video input and output terminals**
These yellow terminals are for sending (OUT) and receiving (IN) video signals. You will only need to use these if you have a monitor television, or for making copies of tapes.
- ⑤ **video channel switch (VIDEO CHANNEL)**
If you connect your VCR to a monitor TV, you set this switch to "OFF/AV." If you connect your VCR to a regular TV, you set the switch to "3" or "4," whichever station is NOT used for broadcasting in your area. (See "Setting Up Your VCR for the First Time" in Chapter 3.)
- ⑥ **timer reset button (TIMER RESET)**
If you press this button, you will erase all of your programmed recording settings, reset the on-screen language, and also reset the clock. Use this button with care.



Now that you're familiar with some of your VCR's features, you're ready to connect the antenna and the television. You won't have to complete all of the connections you see in this chapter — make only those connections that apply to your equipment.

You should keep in mind that there are two steps you need to take to connect your VCR: first, connect the antenna or cable to the VCR, then connect the VCR to the television.

- ◆ **Connecting the Antenna or Cable to the VCR**
- ◆ **Connecting the Television**
- ◆ **Connecting the A/V Network (optional)**

◆ **Connecting the Antenna or Cable to the VCR**

The first thing you need to do is connect the antenna or cable. Because there are at least four different types of antennas, this chapter will show how to connect all of them. You don't need to make all the connections. First, find out what kind of antenna you have. Then, make the connection for that type of antenna. You can then go straight to the next section, "Connecting the Television."

This section shows you:

- Connecting cable antennas,
- Connecting other antennas, and
- Connecting separate UHF/VHF antennas.

Connecting cable antennas

If you have cable TV, this is the only antenna you need to hook up. Because some cable companies require a cable box (for unscrambling cable signals), there are two kinds of cable connections shown: with and without a cable box.

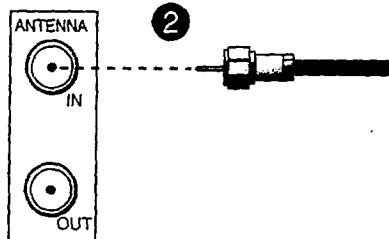

connecting cable without a cable box

- ① Find the "source" cable. It usually comes out of the floor or out of a wall. If it is connected to your TV, disconnect it.
- ② Connect the cable to the ANTENNA IN terminal on the back of your VCR. Screw or push the cable onto the terminal until it is tight.
- ③ When you are finished, go to page 15, "Connecting the Television."

connecting cable with a cable box, if all channels are scrambled

If your cable system scrambles all of its channels, follow the directions below to connect your cable box to your VCR:

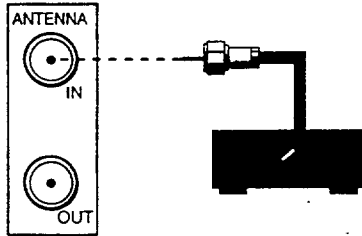

- 1 Disconnect the cable box from the TV.
- 2 Connect the cable from the cable box to the ANTENNA IN terminal on the back of your VCR. Screw or push the cable onto the terminal until it is tight.
- 3 See page 15, "Connecting the Television."

▷ **Important:** If your cable company scrambles all of its channels, you cannot record one channel while watching another.

connecting cable with a cable box, if only some channels are scrambled

If your cable company only requires the use of a cable box for some channels, we suggest using the following connection. This connection will allow you to watch one non-scrambled channel while you record another non-scrambled channel.

Before you begin, you will need:

- a cable splitter,
- four lengths of co-axial cable, and
- a cable A/B switch.

- 1 Find the "source" cable; it usually comes out of the wall or the floor. If it is connected to your cable box, disconnect it.
- 2 Connect the source cable to the "in" terminal on the cable splitter.
- 3 Connect one end of a coaxial cable to an "out" terminal on the splitter. Connect the other end of this cable to the "A-IN" terminal on the A/B switch.
- 4 Connect one end of the second coaxial cable to the other "out" terminal on the splitter. Connect the other end of this cable to the "ANTENNA IN" terminal on the cable box.
- 5 Connect the third coaxial cable to the "ANTENNA OUT" terminal on the cable box. Connect the other end of this cable to the "B-IN" terminal on the A/B switch.

VCR Back Panel

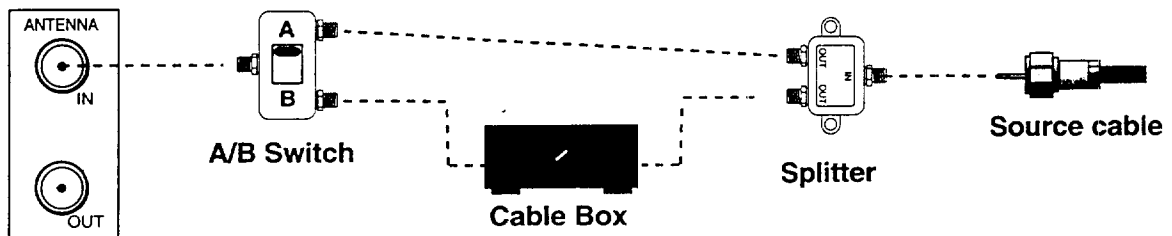

- ⑥ Connect the fourth coaxial cable to the "OUT" terminal on the A/B switch. Connect the other end of this cable to the "ANTENNA IN" terminal on your VCR.
- ⑦ When you are finished, go to page 15, "Connecting the Television."

With this connection, you should set the A/B switch to "B" only when you are recording a scrambled channel. In that case, you should set your VCR to record channel 3 (or 4), and manually set the cable box to the channel you wish to record.

You should leave the A/B switch set to "A" for all other situations.

If you have questions concerning your cable system, please contact your cable company.

▷ **Important:** With this connection, you cannot record a scrambled channel and watch a non-scrambled channel at the same time. You also cannot watch a scrambled channel and record a non-scrambled channel at the same time.

Connecting other antennas

If you don't have cable TV, you'll need to connect a regular antenna. Your antenna may have one of two different kind of ends (called "leads") on it.

The two kinds of leads are:

- 300-ohm flat twin leads that look like this:



- or a 75-ohm round lead that looks like this:



Follow the procedures for connecting the kind of leads your antenna has, then go to page 15, "Connecting the Television."

connecting an antenna with a 300-ohm flat twin lead

(If you have a 300-ohm flat twin lead, you will need to purchase a 300-75 ohm adapter at your local hardware or electronics store.)

- ① Disconnect the antenna from the back of the TV.
- ② Before you can attach the antenna leads to the adapter, you need to expose a 5/8 inch segment of each lead by scraping off the brown plastic covering. Sometimes these leads have "U" shaped clips that fit around the screw, in which case you will not need to peel back the plastic.

Insert lead under screws and tighten.

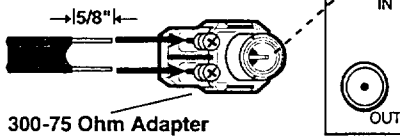

Wrap each exposed end of wire once or twice around the screw shanks of the adapter (or insert the clips under the screw heads). Tighten the screws.

- 3 Push the adapter firmly onto the antenna terminal on the VCR labeled ANTENNA IN.
- 4 When you are finished, go to page 15, "Connecting the Television."

connecting an antenna with a 75-ohm round lead

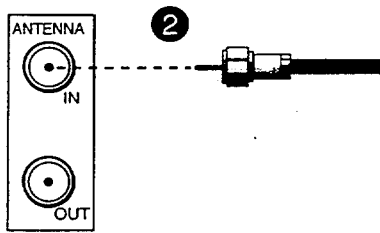

- 1 Disconnect the antenna from the back of the TV.
- 2 Connect the antenna to the ANTENNA IN terminal on the back of the VCR. Screw or push the cable until it is tight.
- 3 When you are finished, go to page 15, "Connecting the Television."

connecting separate UHF/VHF antennas

You may have two separate antennas (one UHF, one VHF) that bring TV signals into your home. If you do, you'll need to combine the two antennas into a single wire to connect them to the VCR. To do this, you'll need an attachment called a combiner (which is available at your electronics store).

The chart below will help you determine the kind of combiner you need.

If your UHF antenna wire looks like this...	...and your VHF antenna wire looks like this...	...then you need a combiner like this.

To connect your antennas:
(please see the illustration on the next page.)

- 1 Disconnect the antennas from the back of the TV.
- 2 Connect the antenna leads onto the combiner.
- 3 Screw or push the combiner onto the ANTENNA IN terminal on the VCR.
- 4 When you are finished, see page 15, "Connecting the Television."

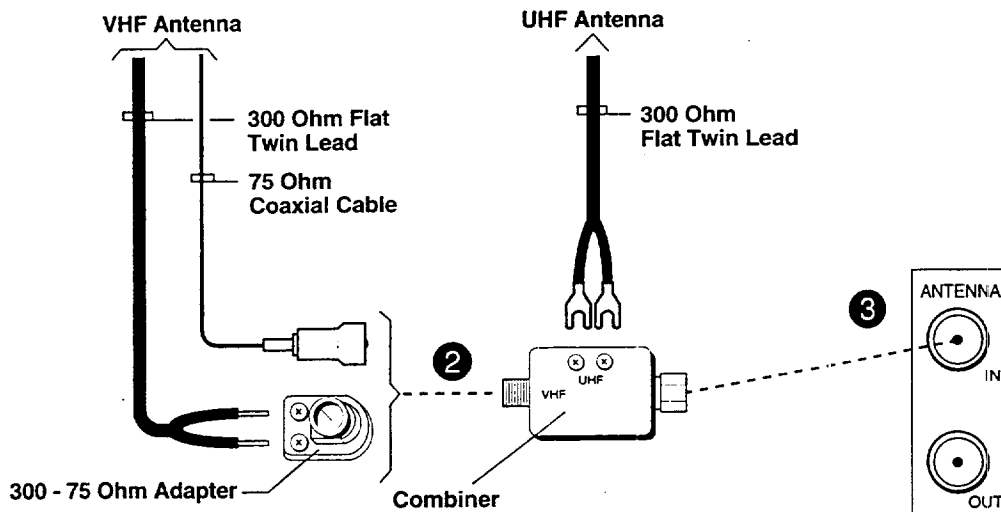

◆ Connecting the Television

Now that you have completed the antenna connections to your VCR, you're ready to connect the VCR to the TV. (If you haven't connected the antenna to the VCR, go to page 11, "Connecting the Antenna or Cable to the VCR.") Because every television is different (especially older model TVs), your VCR may need to be connected in one of a variety of ways. This section shows you:

- Determining if you need a splitter,
- Connecting a regular TV to the VCR, and
- Connecting a TV with audio and video inputs.

Determining if you need a splitter

You should look at the back panel of your TV to see if you need any special equipment to connect the TV to the VCR. You may need an attachment called a UHF/VHF splitter (which is available at your local electronics store). The chart below will tell you if you need a splitter, and what the splitter will look like.

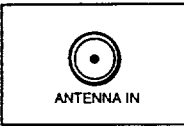
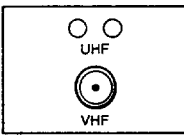
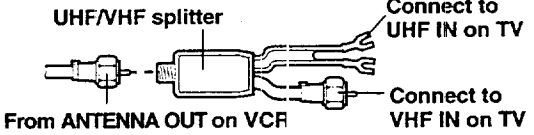
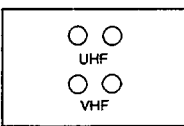
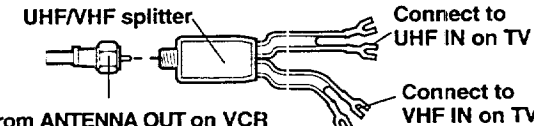
If the TV's antenna terminal looks like this...	...then you will need a splitter that looks like this.
	<p style="text-align: center;">No splitter needed</p>
	
	

Connecting a regular TV to the VCR

To connect a regular TV to the VCR:

- ❶ Take the black cable (called a coaxial cable) that is supplied with your VCR and attach it to the terminal labeled ANTENNA OUT on the back of your VCR.
- ❷ Connect the other end of this cable to the terminal on your TV labeled ANTENNA IN. This terminal is sometimes also called "ANT-IN" or "VHF IN." If you have an older TV without this kind of terminal, you will have to use a splitter and then connect the splitter to the television.
- ❸ If you have a TV with audio and video inputs, you should proceed to the next section, "Connecting a TV with audio and video inputs." Otherwise, your connections are complete.

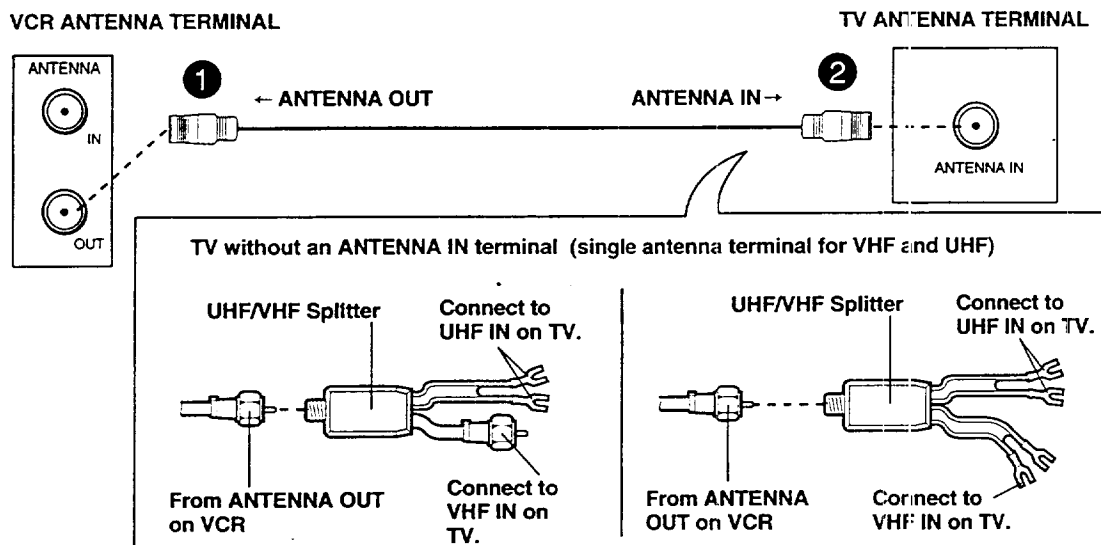

Connecting a TV with audio and video inputs

Your new VCR can be connected to many different types of televisions. Because you purchased a Hi-Fi VCR, you will want to take advantage of its superior sound capability and connect it to a stereo TV system.

Before you begin:

- You should have already completed the section "Connecting a regular TV to the VCR."

connecting a stereo TV with audio video inputs

- ❶ Connect a set of red and white audio cables to the AUDIO OUTPUT terminals on the VCR labeled AUDIO OUT. The red cable is for connecting the right (R) channel and the white cable is for connecting the left (L) channel.

If your TV has only one (mono) audio input, connect only the white (L) output from your VCR.

- 2 Connect the other ends of this cable to the AUDIO INPUT terminals on your TV labeled AUDIO IN.
- 3 Connect a single yellow video cable to the VIDEO OUTPUT terminal labeled VIDEO OUT on the VCR.
- 4 Connect the other end of this cable to the yellow VIDEO INPUT terminal on the TV labeled VIDEO IN.

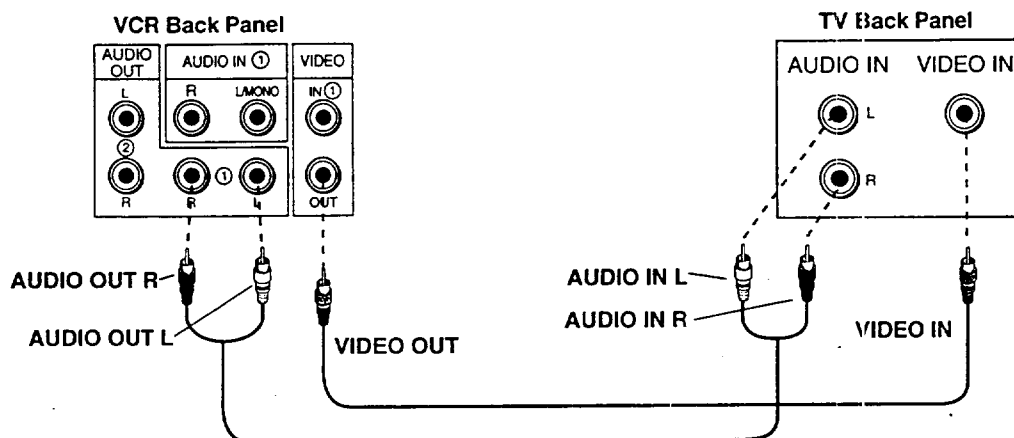

◆ Connecting the A/V Network (optional)

Some Mitsubishi TVs and VCRs have special input and output terminals called the "A/V Network." The primary purpose of the A/V Network is to "pass" remote control codes between Mitsubishi components.

In simple language, when the A/V Network is connected, you can point your VCR remote control at the TV, and the TV will "pass" the commands on to the VCR.

To connect the A/V Network, you will need a cable with a "mini" jack at both ends. (A mini jack is the kind you find on headphones for personal stereos.) A cable may be included with your Mitsubishi TV. If not, you can purchase a cable with mini jacks at your Mitsubishi dealer or an electronics store.

To connect the A/V Network:

- 1 Connect a cable to the terminal on the TV labeled A/V NETWORK OUT or ACTIVE A/V NETWORK. Connect the other end of the cable to the terminal on the VCR labeled ACTIVE A/V NETWORK IN.

- ② If you have another Mitsubishi component equipped with A/V Network, attach a cable to the terminal on the VCR labeled ACTIVE A/V NETWORK OUT. Attach the other end of this cable to the terminal on the other component labeled A/V NETWORK IN or ACTIVE A/V NETWORK IN.

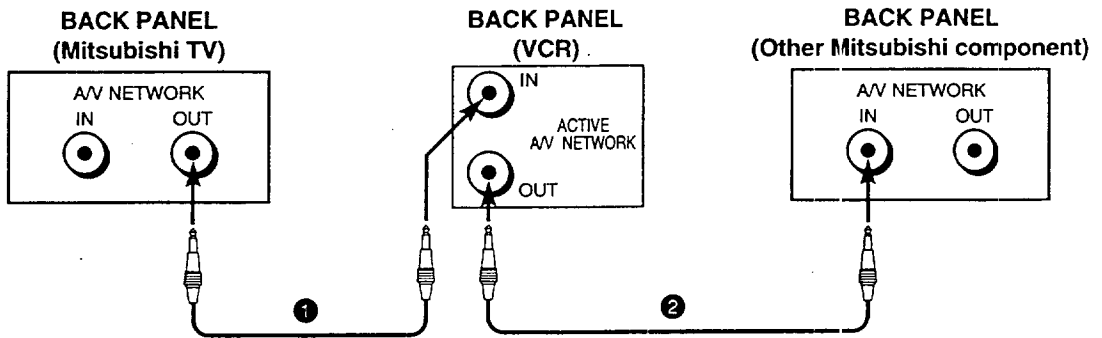

▷ **Important:** Never connect your A/V Network in a loop, as shown below.

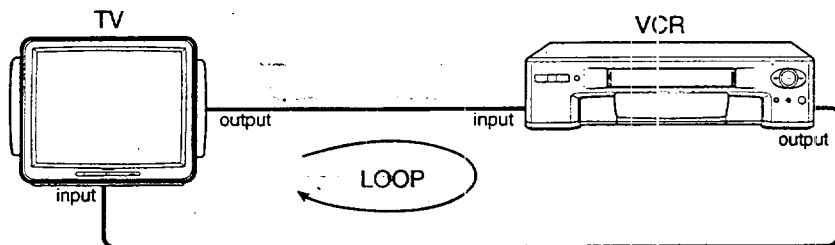

connecting Active A/V Network

Your VCR has the ability to perform certain automated functions in conjunction with Mitsubishi TVs that have ACTIVE A/V NETWORK terminals. These automated functions are called "Active A/V Network."

In order for Active A/V Network to function properly, you must make the connections above and your VCR must be connected to the EXT-1 input terminals of your Mitsubishi TV. Information on how to use the Active A/V Network features begins on page 56.



Now that you've completed your antenna, VCR, and TV connections, you're ready to start enjoying your equipment. To get the most satisfaction out of your VCR, you should carefully read the two sections, "Setting Up Your VCR for the First Time" and "Viewing the Picture Coming from Your VCR." Then you can start exploring what your new VCR can do.

In this chapter, you'll learn:

- ◆ **Setting Up Your VCR for the First Time**
- ◆ **Using the Remote Control**
- ◆ **Viewing the Picture Coming from Your VCR**
- ◆ **Loading and Unloading Tapes**
- ◆ **Playing a Tape**
- ◆ **Selecting the On-screen Language**
- ◆ **Using the Audio and Video Functions**
- ◆ **Using the Menus to Set the Time**
- ◆ **Programming the VCR to Receive TV Channels**
- ◆ **Recording**

◆ **Setting Up Your VCR for the First Time**

It's important that your VCR is set up correctly before you try to work it. If you carefully read this section, you will avoid confusion later and get the most out of operating your system.

This section teaches you about:

- Setting up your VCR if you are using a regular TV, and
- Setting up your VCR if you are using a monitor TV.

Setting up your VCR if you are using a regular TV

- ① Turn on your TV and turn it to channel 3 or 4, whichever is NOT used for broadcast in your area.
- ② Look at the back panel of the VCR and set the VIDEO CHANNEL switch to channel 3 or 4, whichever is the same as the TV.
- ③ Turn the VCR on by pressing the POWER button.

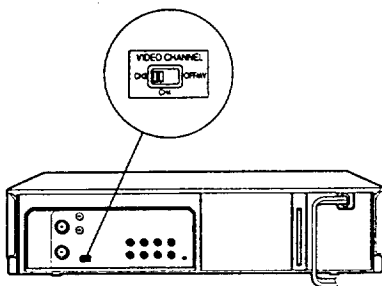

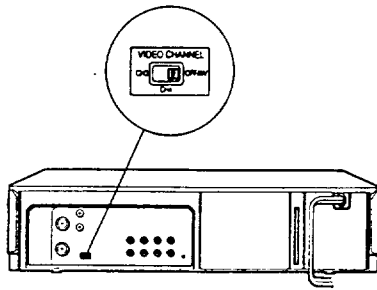

Helpful Information

Setting up your VCR if you are using a monitor TV

- ❶ Turn on your TV and switch it to the correct external input. (For most Mitsubishi TVs, this means pressing the TV's INPUT button until you see the words "Ext-1" on the screen.)
- ❷ Look at the back panel of the VCR and set the VIDEO CHANNEL switch to OFF/AV.
- ❸ Turn the VCR on by pressing the POWER button.

What is a Monitor TV?

A monitor TV is one that has both audio and video inputs. This enables the TV screen to display a picture from an external tuner, such as a VCR tuner.

If your TV does not have both audio and video inputs, it is a "regular" TV.

Once you know what type of TV you are using, you might want to mark it here so that you (and others) won't forget.

Monitor

"Regular"

◆ Using the Remote Control

In this section, you'll learn how to set up and use your remote control. This section includes:

- Using the remote control to operate the VCR, and
- Using the remote control to operate the TV.

Using the remote control to operate the VCR

installing the batteries

- ❶ Unpack two AA size batteries.
- ❷ To remove the back cover, press the ridged area gently, then push the cover in the direction of the arrow and lift.
- ❸ Load the batteries, making sure the polarities (+) and (-) are correct.

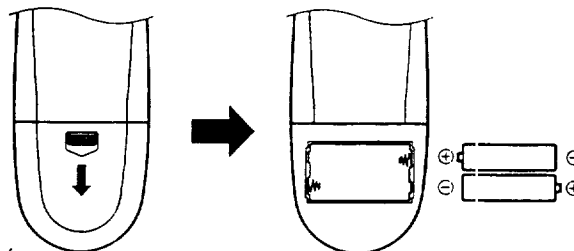

For best results, please use Duracell AA MN-1500 batteries.

operating the remote control

- 1 Press the VCR button on the remote control. This "tells" the remote that you want to control the VCR.
- 2 While within 23 feet of the VCR, point the remote control toward the VCR and press the buttons you desire.

Using the remote control to operate the TV

The HS-U510 remote control can operate many of the frequently-used functions of your TV. This way, you need to use only one remote to operate both your VCR and TV.

The HS-U510 remote control is pre-set to operate Mitsubishi televisions, but it also can operate TVs from other manufacturers. If you need to set your remote control for your particular brand of television, follow the instructions below.

Code Buttons
1*
2*
3*
4
5
6
7
8
9
0
ENTER
CANCEL
INPUT
DISPLAY
VOLUME ▲

*Use button 1, 2, or 3 to set up your remote for use with Mitsubishi TVs.

setting up your remote control to operate your TV

- 1 Turn off your TV.
- 2 On the HS-U510 remote control, press the TV button.
- 3 While holding in the POWER button, press one of the buttons listed in the "Code Buttons" list to the left. If your TV turns on, proceed to step 5.
- 4 If your TV does not turn on, repeat step 3, but try a different button listed in the "Code Buttons" list. Keep trying the buttons until your TV turns on.
- 5 Once your TV has turned on, your remote is set up to operate your brand of TV. You may want to circle the code button that you used.

You will not have to perform this set-up again unless you change the batteries, set up your remote for another brand of television, or you get a new TV.

Once you have correctly set your remote control to operate your TV, you will be able to use the POWER, CHANNEL, VOLUME, MUTE and number buttons to operate your TV.

Additionally, you will be able to use the DISPLAY, INPUT and ENTER buttons, depending on which type of TV you have. Please refer to the table on the next page.

▷ **Important:** Sometimes manufacturers will change the remote control codes for their products, or they will use more than one code. If this is the case, your remote may not be able to control your TV with this remote.

if you used this code button to set up your remote the the DISPLAY button will work like this button...	... and the INPUT button will work like this button...	... and the ENTER button will work like this button ...
1	DISPLAY	INPUT	ENTER
2	---	TV/VIDEO	---
3	DISPLAY	TV/VIDEO	100
4	DISPLAY	---	ENTER
5	DISPLAY	---	ENTER
6	RECALL	TV/VIDEO	---
7	RECALL	TV/TR	ENTER
8	DISPLAY	AUX	100
9	---	TV/VIDEO	---
0	DISPLAY	TV/VIDEO	100
ENTER	---	---	ENTER
CANCEL	DISPLAY	---	100
INPUT	DISPLAY	TV/TR	ENTER
DISPLAY	DISPLAY	TV/VIDEO	ENTER
VOLUME ▲	DISPLAY	TV/VIDEO	---

▷ **Important:** When you replace the batteries in your remote, the remote will return to its initial setting (code button “1”). Repeat the steps on the previous page to reset your remote control.

operating your TV with the HS-U510 remote control

- ❶ Press the TV button on the HS-U510 remote control.
- ❷ Point the remote control towards the remote sensor on the TV and press the desired buttons.
- ❸ To once again control the VCR, press the VCR button.

▷ **Important:** Because of variations among models, some or all buttons may not work, or they may operate different functions than listed above, for your particular TV. If this occurs, you may need to use your TV remote control.

◆ Viewing the Picture Coming from Your VCR

This is the most important part of using your VCR, but often the most confusing: how do you view a picture coming from the VCR?

Before you begin, you should know:

- whether you are viewing a “Monitor TV” or a “Regular TV.” (See page 20.)

This section teaches you about:

- Viewing the picture coming from your VCR if you are using a regular TV, and
- Viewing the picture coming from your VCR if you are using a monitor TV.

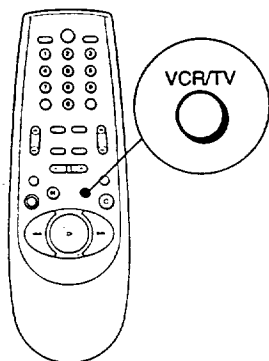

Viewing the picture coming from your VCR if you are using a regular TV

- ❶ Turn on your TV and turn it to channel 3 or 4.
- ❷ Turn on the VCR by pressing the POWER button.
- ❸ Check to see if the "VCR" light on the front panel display is lit. If it is not lit, press the VCR/TV button until it is lit. You are viewing the picture from your VCR!

With this set-up, you will use the VCR/TV button when recording, when viewing tapes or broadcast stations through your VCR, or before using the VCR's menus. You also use the VCR/TV button to switch back to normal TV viewing.

Viewing the picture coming from your VCR if you are using a monitor TV

- ❶ Turn on your TV and switch it to the correct external input. (For most Mitsubishi TVs, this means pressing the TV's INPUT button until you see the words "Ext-1" on the screen.)
- ❷ Turn the VCR on by pressing the POWER button. You are viewing the picture from your VCR!

▷ **Important:** If you wish to return to normal TV viewing, switch your TV's input back to its previous position. If your system includes a home theater receiver or an A/V receiver, please refer to your home theater receiver's owner's guide.

◆ Loading and Unloading Tapes

▷ **Important:** Tapes can be loaded into your VCR as long as the VCR is plugged in. Even when the VCR POWER is off, loading a tape will automatically turn the VCR on. Use only tapes that have a **VHS** label.

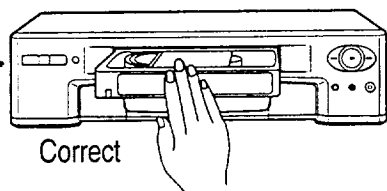

Correct

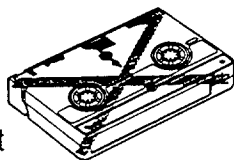

Incorrect

Loading a tape

- ❶ Hold the tape so that the long narrow edge with the contents label faces towards you. The other edge is hinged and should face towards the VCR. The plastic window that shows the videotape should face up.
- ❷ Gently insert the tape into the cassette slot until the VCR automatically takes it in.

If you load a tape that has not yet been recorded, your VCR will test the tape with the PerfectTape feature (see page 48).

▷ **Important:** Your new VCR will eject the tape if you improperly load it. If the VCR ejects the tape, remove the tape, check to see that the contents label is facing you, that the geared tape reels are facing downwards, wait a few seconds, and try again.

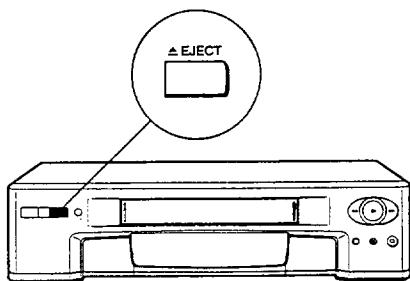

► **Important:** You cannot eject a tape while recording. You must first press STOP.

Unloading a tape

- ❶ Press the EJECT button on the front of the VCR. If the VCR POWER is off, the VCR will turn on, eject the tape, then turn off.
- ❷ Remove the tape.

preventing accidental erasure

Tapes come with a tab which, when removed, prevents you from recording over them. If you attempt to record over a tape that has had this tab removed, the VCR will eject it and briefly display an error message. To record over such a tape, simply place a piece of vinyl tape over the opening.

using repaired tapes

► **Warning:** We recommend that you take any broken or torn tapes to a professional for repair. If you repair a torn tape with improper materials, you could damage your VCR when you play the tape.

head cleaning

Your VCR automatically cleans the head and the drum of the VCR whenever you load a tape. If you see “noise” or snow when playing a tape, eject the tape, re-load the tape, then wait 3 or 4 seconds. Repeat this process several times to improve the picture.

◆ Playing a Tape

Now that your VCR is connected and properly set up, and you know how to view a picture coming from your VCR, it's time to play a tape. This section describes:

- Playing back a tape, and
- Using basic playback controls.

Playing back a tape

Before you begin, you need to know:

- how to view the picture coming from your VCR (page 22).

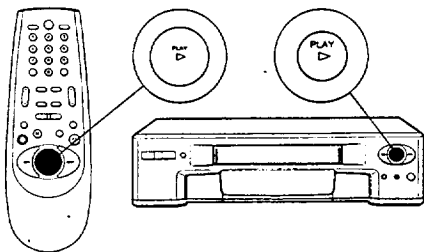

- ❶ Load a pre-recorded cassette.
- ❷ Press the PLAY button either on the front panel or on the remote control.

The VCR will automatically play the tape at the correct speed. When the VCR reaches the end of the tape, it will automatically rewind the tape and stop.

Playing a tape is also an Active A/V Network feature. (For more information, see page 56.)

Using basic playback controls

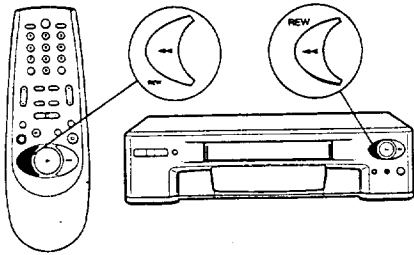

rewinding a tape

Press the REW button on the remote control or on the front panel.

If the tape is stopped, you will begin rewinding. If the tape is playing, you will begin "reverse speed search."

► **Important:** If you press the POWER button while the tape is rewinding, the VCR will turn OFF when the beginning of the tape is reached.

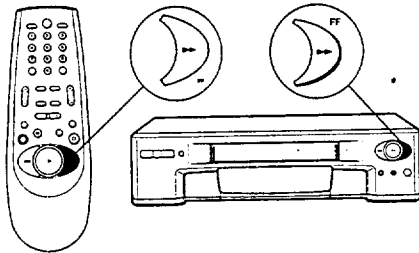

fast forwarding a tape

Press the FF button on the remote control or on the front panel.

If the tape is stopped, you will begin fast forward. If the tape is playing, you will begin "forward speed search."

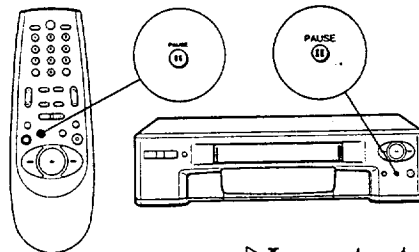

pausing a tape

Press the PAUSE button on the front panel or on the remote control to freeze the picture on the screen.

► **Important:** If you leave the VCR in pause for 5 minutes when playing a tape, the VCR will automatically stop to prevent damage to the tape. If you pause the tape for more than 5 minutes during recording, the VCR will stop recording.

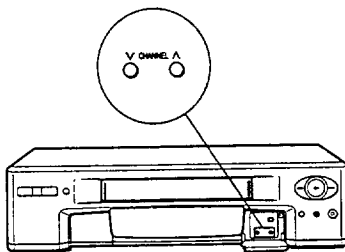

controlling vibration during still frame

If the picture vibrates during still frame, press the CHANNEL buttons on the front panel until the picture is steady.

◆ Selecting the On-screen Language

You can set your VCR to display on-screen messages, menus, and functions in one of three languages: English, Spanish, or French. You should do this before you use the menus or set any audio/video functions.

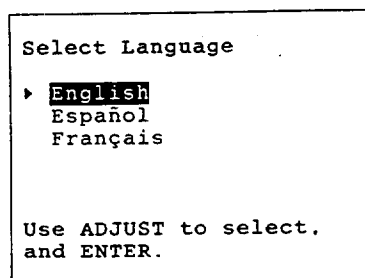

Before you begin, you need to know:

- how to view the picture coming from your VCR. (See page 22.)
- 1 Make sure you are viewing the picture coming from your VCR. Then, press the MENU button on the remote control. If this is the first time the menus have been used, you will see the menu for selecting an on-screen language.

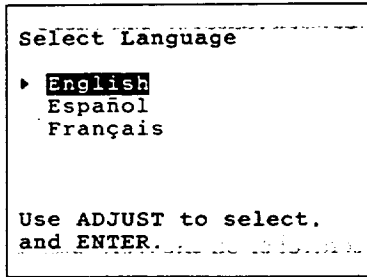

- ② Press the JOG/ADJUST buttons on the remote control to move the cursor next to the desired language.
- ③ Press the ENTER button on the remote control. The menu will change to the “VCR Main Menu.”
- ④ Press the MENU button to exit the menus.

▷ **Important:** The “Select Language” menu is unique. While all other menus can be accessed at almost any time, the “Select Language” menu will not automatically appear again after it is first set. To see the “Select Language” menu, press the TIMER RESET button on the rear panel to clear the language setting. Then, follow the instructions above.

◆ Using the Audio and Video Functions

You can use the remote control to select many of the VCR’s audio and video functions and adjust their settings. The VCR will display the settings on the television’s screen.

This section will teach you about:

- Selecting and adjusting the audio and video functions, and
- Descriptions of audio and video functions.

The audio and video functions you can adjust are:

- monitor,
- normal record,
- level meter,
- front display,
- record speed, and
- tape.

Selecting and adjusting the audio and video functions

Below are instructions on how to select and adjust these functions. If you are not familiar with the purpose of these functions, definitions begin on the next page.

Before you begin, you need to know:

- how to view the picture coming from your VCR (page 22).

- ① Press the AUDIO/VIDEO button on the remote control to see the function menu.

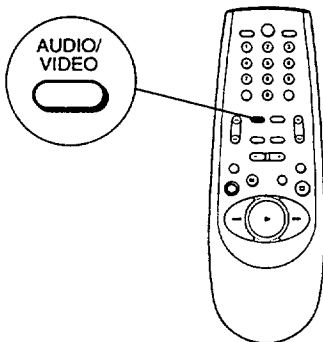

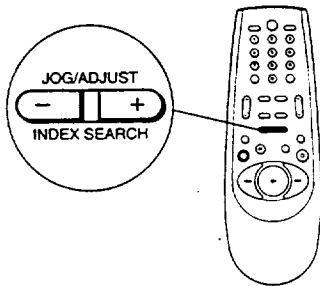

- ② Press the AUDIO/VIDEO button until the function you want to select appears.
- ③ Press the JOG/ADJUST buttons on the remote to adjust the setting.

The functions will disappear if you do not press any buttons for 5 seconds.

▷ **Important:** The audio and video function displays do not appear when the VCR menu is displayed and during special effects playback. Additionally, the recording speed ("REC speed") and "Tape" functions do not appear during playback.

Descriptions of audio and video functions

Following is a list of the audio and video functions, along with descriptions of their uses and their settings.

audio monitor

The monitor function allows you to listen to the various audio tracks that your VCR is capable of recording. You can choose to listen to a MONO track, both channels of the STEREO track, or either of the channels (left (L) and right (R)) of the stereo track.

- The MONO track is much lower in quality than the others. However, the monitor is automatically set to MONO if you are watching a tape that was not recorded in VHS Hi-Fi.
- Choose L to listen to the left channel of a stereo track.
- Choose R to listen to the right channel of the stereo track.
- Choose STEREO to listen to both the left and right channels of the stereo track.

▷ **Important:** If you have your VCR connected to a surround sound system, you must set the audio monitor to STEREO. Surround sound relies on the combination of left and right channels to create the rear channels effects.

normal recording (Normal REC)

When your VCR is recording, it actually records the audio portion of a program twice: once on the stereo Hi-Fi tracks, and once on the mono track. Additionally, your VCR is able to receive Separate Audio Program broadcasts, also known as an SAP broadcast. A SAP broadcast is an alternative audio soundtrack for your program; it is often a version in another language.

You can use the normal recording function to set the VCR to record the SAP broadcast on the mono track by choosing SAP. Otherwise, choose L+R. In either case, the main program is recorded on the stereo Hi-Fi track. Also, if there is no SAP broadcast, the VCR will record the main program on the mono track.

Be careful if you choose SAP. If you play your tapes back on a non-Hi-Fi VCR, you will be able to hear only the mono track. You may have to watch a show in a language you don't understand!

level meters (Level meter)

Use the level meters function to turn the front panel level meters on or off.

front display (Front disp)

Use the front display function to dim or brighten the front panel.

record speed (REC speed)

The speed at which you record has an effect on picture quality. SP will produce the best picture quality and can record up to two hours of video on a T-120 tape. Mitsubishi's EP speed has only slightly poorer quality, but records up to six hours on a T-120. Your VCR can only record in SP or EP speed, but can play back tapes recorded in SP, LP or EP.

tape (Tape)

Adjust this function to ensure the accuracy of the Tape Remaining display. If you are using a tape that is two hours long or less (labeled T-30 through T-120), set this function to "T-120." If you are using a tape labeled T-160, set the function to "T-160." If you are using a tape label T-180, set the function to "T-180." You cannot use this function with a tape that is less than 30 minutes long, or with a tape labeled "T-210."

◆ Using the Menus to Set the Time

This section will show you how to use the on-screen menus. You will use the menus to operate many features, such as setting the time, programming to record, and memorizing channels.

Before you begin, you need to know:

- how to view the picture coming from your VCR (page 22).

① Make sure you are viewing the picture coming from your VCR. Then, press the MENU button on the remote control. You will see the "VCR Main Menu." Make sure the cursor is next to the words "First Time Set-Up." If it is not, use the JOG/ADJUST buttons to place the cursor there.

② Press ENTER. The "First Time Set-Up" menu will appear. The cursor will be next to "Set the clock." Press the ENTER button.

③ You will see the "Set the clock" menu. The cursor will be next to the word "Month." Press the JOG/ADJUST buttons until the correct month appears on screen. Press the ENTER button.

```

◆ First Time Set-Up
Your choices are:
▶ Set the clock
  Customize choices
  Memorize channels
  Add/delete channels

Use ADJUST to select
and ENTER.
Press MENU for Main Menu

```

```

Set the clock
▶ Month      June
  Year      1995
  Date      1 Thursday
  Clock     12:00 PM
  Daylight savings (OFF)

Use ADJUST to select
and ENTER. Press
MENU for Set-Up Menu

```

```

Set the clock
Month      June
▶ Year     -1995-
Date       1 Thursday
Clock      12:00PM
Daylight savings (OFF)

Use ADJUST to select,
and ENTER. Press
MENU for Set-Up Menu

```

```

Set the clock
Month      June
Year       1995
▶ Date     -18 Sunday-
Clock      12:00PM
Daylight savings (OFF)

Use ADJUST to select,
and ENTER. Press
MENU for Set-Up Menu

```

```

Set the clock
Month      June
Year       1995
Date       18 Sunday
▶ Clock    -7:00PM-
Daylight savings (OFF)

Use ADJUST to select,
and ENTER. Press
MENU for Set-Up Menu

```

```

Set the clock
Month      June
Year       1995
Date       18 Sunday
▶ Clock    7:30PM
Daylight savings (OFF)

Use ADJUST to select,
and ENTER. Press
MENU for Set-Up Menu

```

```

Set the clock
Month      June
Year       1995
Date       18 Sunday
Clock      7:30PM
▶ Daylight savings (OFF)

Use ADJUST to select,
and ENTER. Press
MENU for Set-Up Menu

```

4 The cursor automatically moves to the word "Year." Press the JOG/ADJUST buttons to set the year. Press the ENTER button.

5 The cursor automatically moves to the word "Date." Press the JOG/ADJUST buttons to set the date. Press the ENTER button.

6 The cursor automatically moves to the word "Clock." The hour numbers and the am/pm indicator will be blinking. Press the JOG/ADJUST buttons to set the hour and am/pm at the same time. The JOG/ADJUST + button moves the clock forward; the JOG/ADJUST - button moves the clock backwards.

Press the ENTER button.

7 The minutes numbers will now be blinking. Press the JOG/ADJUST buttons to set the minutes. When you have set the correct time, press the ENTER button.

8 The cursor automatically moves to the words "Daylight savings." If you are currently following Daylight Savings Time, use the JOG/ADJUST buttons to select "ON"; otherwise, select "OFF." Then, press ENTER. You will see the "First Time Set-Up" menu and the clock will start running.

9 Press the MENU button once to return to the "VCR Main Menu"; press the MENU button again to turn off the menus.

setting the clock forward or backward by one hour (adjusting for Daylight Savings Time)

You can adjust the Daylight Savings Time setting without entering the menus. With the VCR turned off, press the INPUT button on the front panel. If Daylight Savings is currently ON, this will turn it off and set the clock back one hour. If it is currently OFF, this will turn it on and set the clock forward one hour.

► **Important:** Each time you press the INPUT button, the Daylight Savings setting will switch between "ON" and "OFF." Any time you adjust this setting, you should check any pro-programmed recording to be sure they are set to the correct times.

▷ **Important:** If you want to adjust the clock when your VCR is in stand-by for programmed recording, simply press the POWER button *on the front panel*. This turns off the programmed recording light, but the VCR will remain turned off. When you finish adjusting the clock, press the POWER button again, and make sure that the programmed recording light is back on.

If you have a Mitsubishi TV with both Active A/V Network and “StarSight” features, you don’t have to set the time on your VCR. See your TV Owner’s Guide for details.

◆ Programming the VCR to Receive TV Channels

Before your VCR can receive television channels, you need to program all of the channels you can receive into your VCR. Fortunately, our menu system makes this an easy process. This section will also explain some other channel-related functions. This section explains:

- Programming channels automatically,
- Using video mute,
- Adding and deleting channels, and
- Selecting a channel.

Programming channels automatically

Using this process, your VCR will automatically tune in all of the television stations you can receive. You can later get rid of unwanted or unused stations.

A special note to cable box subscribers

If your local cable box company scrambles some or all stations, and/or requires you to use a cable box, then your ability to program channels will be limited. The cable box receives all of your channels and then sends only one to your TV (and your VCR), usually on channel 3 or 4.

If your cable box or cable system seems incompatible with your new VCR, call your cable company. They may be able to provide solutions to your problems.

Before you begin, you should:

- have completed all connections between your VCR, TV, and cable or antenna; (see page 11)
- know how to view the picture coming from your VCR; (see page 22) and
- know how to use the menus. (See page 23.)

To program channels automatically:

- ① Set the VCR’s input to tuner. To do this, press the INPUT button on the remote control until a channel number appears on the screen or on the front panel fluorescent display.

◆ **First Time Set-Up**
 Your choices are:
 Set the clock
 Customize choices
 ▶ **Memorize channels**
 Add/delete channels

Use ADJUST to select,
 and ENTER.
 Press MENU for Main Menu

- 2 Press the MENU button on the remote control. You will see the "VCR Main Menu" on the TV screen.
- 3 Use the JOG/ADJUST buttons to move the cursor next to "First Time Set-Up." Press the ENTER button.
- 4 The "First Time Set-Up" menu appears on your screen. Press the JOG/ADJUST buttons to move the cursor next to "Memorize channels." Press the ENTER button.

▶ **Important:** If you are recording, playing back a tape, or receiving a video signal from an external input, then the words "Not available" will flash and an error message will appear. To correct this, stop the tape or switch the VCR's input to tuner.

Memorize channels
 What type of antenna is connected to the VCR?
 ▶ **Cable**
 Indoor/outdoor

Use ADJUST to select,
 and ENTER. Press MENU for Set-Up Menu

- 5 You will see the menu for automatically memorizing channels. Using the list below as a reference, press the JOG/ADJUST buttons to select the kind of antenna you connected.
 - If you are using any cable combination, including a cable box with an A/B switch, choose "Cable."
 - If you are using an antenna that receives only over-the-air broadcasts, such as "rabbit ears" or a roof-mounted antenna, choose "Indoor/outdoor."
 After you have made your choice, press ENTER.

Memorize channels
 Now memorizing all the stations you can receive
 Channel 3
 Stand by this may take a few minutes

To cancel memorization,
 press CANCEL

- 6 You will see an on-screen message and the display on the front of your VCR showing you that the VCR is memorizing the stations you can receive. You can cancel the memorization at any time by pressing CANCEL on the remote control.

After the VCR is finished programming all the channels, the screen will return the VCR's picture.

▶ **Important:** Automatic programming may include vacant channels if there was a noise or stray signal on the channel. If this occurs, you can manually delete the channels using the procedure in the section, "Adding and deleting channels."

Using video mute

When you turn video mute ON, any blank section of tape, or any station with a weak signal, will be replaced by a blue screen. The sound will also be turned off. If there is a time when you would like to try to tune in a weak station, turn video mute OFF.

Before you begin, you should know how:

- to view the picture coming from your VCR; (see page 22)
- to use the menus. (See page 28.)

▲ **VCR Main Menu**
 Your choices are:
 Program to record
 Advanced Features
 Search by time
 ▶ **First Time Set-Up**

Use ADJUST to select,
 and ENTER.
 Press MENU to exit menus

- 1 Press the MENU button on the remote control. The "VCR Main Menu" appears on your TV.
- 2 Use the JOG/ADJUST buttons to move the cursor next to "First Time Set-Up." Press the ENTER button.

```

◆ First Time Set-Up
Your choices are:
  Set the clock
  ▶ Customize choices
  Memorize channels
  Add/delete channels

Use ADJUST to select,
and ENTER to change
settings. Press MENU
for Main Menu

```

```

Customize choices
PerfectTape (AUTO)
▶ Video mute (ON )
A/V Network (OFF)

Use ADJUST to select,
and ENTER to change
settings. Press MENU
for Set-Up Menu

```

- 3 The "First Time Set-Up" menu appears on your screen. Use the JOG/ADJUST buttons to move the cursor next to "Customize choices" and press the ENTER button.
- 4 Use the JOG/ADJUST buttons to select "Video mute." Then, press the ENTER button to set video mute to ON or OFF.
- 5 Press the MENU button once to return to the "First Time Set-Up" menu; press the MENU button a second time to return to the "VCR Main Menu;" press the MENU button a third time to turn off the menus.

Adding and deleting channels

If necessary, you can manually add or delete channels after you have completed the automatic channel programming.

Before your begin, you should know:

- how to view the picture coming from your VCR; (page 22)
- how to use the menus. (See page 28.)

- 1 Make sure the video mute is ON. (See page 31.)
- 2 Set the VCR's input to "tuner." To do this, press the INPUT button on the remote control until you see a channel number on the fluorescent display panel.
- 3 Press the MENU button on the remote control. The "VCR Main Menu" appears on your TV.
- 4 Press the JOG/ADJUST buttons on the remote control to move the cursor next to "First Time Set-Up." Press the ENTER button on the remote control.
- 5 You will see the "First Time Set-Up" menu. Press the JOG/ADJUST buttons to move the cursor next to "Add/delete channels." Press the ENTER button.

```

◆ First Time Set-Up
Your choices are:
  Set the clock
  Customize choices
  Memorize channels
  ▶ Add/delete channels

Use ADJUST to select,
and ENTER to change
settings. Press MENU
for Main Menu

```

► **Important:** If you are recording, playing back a tape, or receiving a video signal from an external input, then the words "Not available" will flash and an error message will appear. To correct this, stop the tape or switch the VCR's input to tuner.

```

Add/delete channels
Channel 39
      Not in memory

Use ADJUST to select
a channel. Use ENTER
to add it. CANCEL to
delete it. Press
MENU for Set-Up Menu

```

- 6 You will see the screen for adding or deleting channels. Use the JOG/ADJUST buttons to select the channel to be added or deleted. Press the ENTER button to add the channel or press the CANCEL button to delete it.

- 7 When you are finished adding or deleting channels, press the MENU button once to return to the "First Time Set-Up" menu; press the MENU button a second time to return to the "VCR Main Menu"; press the MENU button a third time to turn off the menu.

▷ **Important:** If you use automatic programming again, you will lose all of the manual changes you made. All of the channels you deleted will be added; all of the channels you added will be deleted.

Selecting a channel

Now that you have programmed your channels, and added or deleted some, you will want to be able to select channels. (If you have not yet programmed your channels, see page 30, "Programming channels automatically".)

There are two ways to select channels: sequentially or directly.

selecting channels sequentially

Press the CHANNEL buttons on the remote control or on the VCR front panel. This will cycle through the channels in sequential numerical order.

selecting channels directly

You can select channels directly by using the number buttons on the remote control. For example, to choose channel 23, press the "2" button, then the "3" button.

To select a single digit channel, such as channel 5, press the "0" button, then the number button, "5." You can also press the number button "5," then press ENTER.

▷ **Important:** The VCR can receive VHF channels 2–13, UHF channels 14–69, and cable channels 1–125. If you enter numbers other than these, the channel will not change.

◆ Recording

Your new VCR offers a wide variety of recording options that take full advantage of our advanced electronics. This section tells you about the following recording procedures:

- Recording a current broadcast,
- Programming your VCR to record,
- Using One-Touch Recording (OTR),
- Using One Key Programming,
- Using Quick Program, and
- Notes about programmed recording.

Recording a current broadcast

Before you begin, you need to know:

- how to view the picture coming from your VCR (page 22.)

To record a TV program that you are watching on the VCR:

- 1 Load a tape that has not had its erasure tab removed into the VCR. If you have not yet recorded on this tape, the VCR will test the tape with the PerfectTape feature. (See page 48.)
- 2 Set the VCR's input to tuner. To do this, press the INPUT button on the remote control until a channel number appears on the screen or on the front panel fluorescent display.
- 3 If you have not already done so, set the speed at which you would like to record. (See "Using the Audio and Video Functions" on page 26.)
- 4 Select the channel you would like to record by using the CHANNEL buttons on the remote control or on the front panel. (If you are using a cable box, select channel 3 or 4 on the VCR, and change the channel on the cable box. Additionally, if you are using an A/B switch, remember to set the switch to the correct position.)
- 5 Press the record button (REC) on the remote control or the record button (REC/OTR) on the front panel of the VCR.

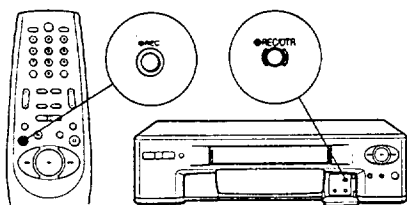

Recording will start. When you reach the end of the tape, the VCR will automatically rewind. You can stop recording at any time by pressing the STOP or PAUSE button. To resume recording from STOP, press REC. To resume recording from PAUSE, press PAUSE. You can't use the REC/OTR button on the front panel to resume recording from record-pause.

▷ **Important:** If you pause the VCR for five minutes, recording will stop automatically to protect the tape. If you record in extended play (EP), you will only be able to play the tape on a VCR equipped for EP play, such as this one.

If you attempt to record on a tape that has had its erasure prevention tab removed, the VCR will eject the tape and briefly display an error message on your TV screen.

using record cancel

Record cancel allows you to stop a recording that you accidentally started and rewind the tape to the exact point where recording started. This feature is very useful if you are recording and editing out commercials as you go. If you accidentally start recording and the commercials aren't over, you can easily go back.

You can use record cancel only if you start your accidental recording from the record-pause mode.

To use record cancel, press the rewind button (REW) on the remote control or on the front panel within eight seconds of when you accidentally start recording. The VCR rewinds to where the recording started and enters the record-pause mode.

Programming your VCR to record

You can program your VCR to record with the help of Mitsubishi's on-screen operating system. You can schedule up to eight recording "events" within a one month period.

Before you begin:

- you need to know how to view the picture coming from your VCR; (see page 22) and
- you must have set the clock. (See page 28.)

To program your VCR to record:

① Load a tape that has not had its erasure tab removed into the VCR. If you have not yet recorded on this tape, the VCR will test the tape with the PerfectTape feature. (See page 48.)

② Press the MENU button on the remote control. The "VCR Main Menu" appears on your screen. Use the JOG/ADJUST buttons on the remote control to move the cursor next to "Program to record." Press the ENTER button.

If there is already a programmed recording, you will see the "recap" screen. You can choose an empty recording slot, or wait four seconds and the VCR will automatically choose the first empty slot.

③ You will see the "Program to record" menu. Press the JOG/ADJUST buttons to choose the channel you would like to record (for example, channel 2). Press the ENTER button.

If you are using a cable box, enter the channel number on which the cable box sends a signal to your VCR (usually channel 3 or 4).

```

▲ VCR Main Menu
Your choices are:
▶ Program to record
  Advanced Features
  Search by time
  First Time Set-Up

Use ADJUST to select,
and ENTER.
Press MENU to exit menus
  
```

```

◆ Program to record
▶ Channel
  Day
  Start time  ----
  Stop time   ----
  Record speed AUTO

Use ADJUST to select,
and ENTER.
Press CANCEL to clear
  
```

▷ **Important:** If you wish to record from an external source, press the INPUT button or the JOG/ADJUST buttons until "External L1" or "External L2" appears. Select "External L1" when you wish to record from a source connected to the input terminals on the rear panel. Select "External L2" when you wish to record from a source connected to the terminals on the front panel.

```

◆ Program to record
Channel
▶ Day      -Monday 19-
  Start time  ---
  Stop time   ---
  Record speed AUTO

Use ADJUST to select,
and ENTER.
Press MENU for Main Menu
  
```

④ The "Day" will flash. Press the JOG/ADJUST buttons to highlight the day on which you want to record (for example, Monday the nineteenth). Press the ENTER button.

▷ **Important:** When selecting a day, your choices are: a single day up to one month away, every day from Monday through Friday, or the same day every week. To program for every day from Monday through Friday (to tape a soap opera, for example), press the JOG/ADJUST buttons until "Monday-Friday" appears. To program the same day every week (to tape your favorite sitcom, for example), press the JOG/ADJUST buttons until "Every" and the desired day of the week appear.

```

◆ Program to record
Channel      2
Day         Monday 19
▶ Start time 11:00AM
Stop time   -----
Record speed AUTO

Use ADJUST to select,
and ENTER.
Press MENU for Main Menu

```

- 5 The hour numbers of the starting time, along with the am/pm indicator, will flash. Press the JOG/ADJUST buttons to set the hour when you wish recording to start. Press the ENTER button.

```

◆ Program to record
Channel      2
Day         Monday 19
▶ Start time 11:30AM
Stop time   -----
Record speed AUTO

Use ADJUST to select,
and ENTER.
Press MENU for Main Menu

```

- 6 The minute numbers of the start time will flash. Press the JOG/ADJUST buttons to set the minutes when you wish recording to start. Press the ENTER button.

```

◆ Program to record
Channel      2
Day         Monday 19
Start time  11:30AM
▶ Stop time  1:00PM
Record speed AUTO

Use ADJUST to select,
and ENTER.
Press MENU for Main Menu

```

- 7 The hour numbers of the stop time, along with the am/pm indicator, will flash. Press the JOG/ADJUST buttons to set the hour when you wish recording to stop. Press the ENTER button.

```

◆ Program to record
Channel      2
Day         Monday 19
Start time  11:30AM
▶ Stop time  1:30PM
Record speed AUTO

Use ADJUST to select,
and ENTER.
Press MENU for Main Menu

```

- 8 The minute numbers of the stop time will flash. Use the JOG/ADJUST buttons to set the minutes when you wish recording to stop. Press the ENTER button.

```

◆ Program to record
Channel      2
Day         Monday 19
Start time  11:30AM
Stop time   1:30PM
▶ Record speed SP

Use ADJUST to select,
and ENTER.
Press MENU for Main Menu

```

- 9 Press the JOG/ADJUST button to set the recording speed to SP, EP or AUTO. (See "auto speed programming" on page 42 for an explanation of the auto speed recording feature.) Press the ENTER button.

◆ Program to record					
CH	DAY	ON	OFF		
▶ 2	MO19	11:30A	1:30P	SP	
---	---	---	---	SP	
---	---	---	---	SP	
---	---	---	---	SP	

Use ADJUST to select,
and ENTER.
Press MENU for Main Menu

- ⑩ The contents of the programmed memory will appear on the "recap" screen.
- ⑪ To program additional recording times, select an empty program line by pressing the JOG/ADJUST buttons. Then, press the ENTER button. You will return to the "Program to record" screen. Continue the programming procedure from step ③.

▷ **Important:** Only four of the eight program lines appear on-screen at any one time. To see additional program lines, press the JOG/ADJUST buttons to scroll the lines on the screen.

- ⑫ When you are finished with all programming, turn the VCR power OFF and be sure the programmed recording light (☐) is lit on the fluorescent display. However, if you have a cable box, leave the box turned ON, tuned to the station you wish to record. If you are using an A/B switch, remember to set the switch to the correct position.

changing settings while programming

If you wish to change one of your settings (such as start time) while you are programming, use the ENTER and CANCEL buttons on the remote to select the setting you wish to change. ENTER will move you forward through the list, while CANCEL will move you backwards. Then, use the JOG/ADJUST buttons to change the setting.

▷ **Important:** If you press CANCEL while the cursor is next to the channel number, you will cancel the entire program.

Using One-Touch Recording (OTR)

One-Touch Recording (also called OTR) is a way to begin recording immediately, but have your VCR stop recording and turn off automatically after your show is over.

Before you begin, you need to know how:

- to view the picture coming from your VCR. (See page 22.)

To use OTR:

- ① Load a tape that has not had its erasure tab removed into the VCR. If you have not yet recorded on this tape, the VCR will test the tape with the PerfectTape feature. (See page 48.)
- ② Set the VCR's input to tuner. To do this, press the INPUT button on the remote control until a channel number appears on the screen or on the front panel fluorescent display.
- ③ If you have not already done so, set the speed that you would like to record. (See "Using the Audio and Video Functions," page 26.)

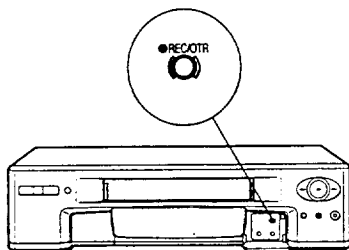

- 4 Select the channel you would like to record by using the CHANNEL buttons on the remote control or the front panel.

If you are using a cable box, select channel 3 or 4 on the VCR, and change the channel on the cable box. Additionally, if you are using an A/B switch, remember to set the switch to the correct position.

- 4 Press the REC/OTR button on the front panel twice. The first time you press the button, recording will begin. The second time you press the button, 30 minutes is added to the OTR timer (which is displayed on the front panel).
- 5 Press the REC/OTR button for each 30 minutes you want to add to the OTR timer, up to 4 hours. If you press the button 10 times, you will see the word "End" on the front panel display; the VCR will record until the end of the tape. If you press the button an eleventh time, the VCR will resume normal recording.

The OTR timer will begin to count down. When it reaches zero, the VCR will stop recording and turn off. If you have previously programmed your VCR to record, the VCR will be ready to record what you've programmed.

▷ **Important:** If you attempt to record on a tape that has had its erasure prevention tab removed, the VCR will eject the tape and briefly display an error message on your TV screen.

If you program too much time into the OTR timer

If you program too much time into the OTR timer, continue pressing the REC/OTR button. You will "cycle" around once you have reached the 4-hour point. You can start over, adding time in 30 minute intervals.

How OTR affects other controls

If you press the PAUSE button during OTR, the VCR will pause recording, but the OTR timer continues to count down.

If you press STOP during OTR, you erase the OTR programming.

Using One Key Programming

One Key Programming is a programming method that is simple to use and easy to learn, without using the remote control.

Before you begin:

- you need to know how to view the picture coming from your VCR; (see page 22) and
 - you must have set the clock. (See page 28.)
- 1 Load a tape that has not had its erasure tab removed into the VCR. If you have not yet recorded on this tape, the VCR will test the tape with the PerfectTape feature. (See page 48.)

```

◆ Program to record
▶ Channel 2
  Day
  Start time ----
  Stop time ----
  Record speed AUTO

Select with O.K. PROGRAM,
then pause for 4 seconds

```

- ② Press the ONE KEY PROGRAM button on the front panel. (If you have not set the time, the "Set the clock" menu will appear. Set the clock, and then proceed.) If there is already a program in the VCR's memory, you will see the "recap" screen. You can use the ONE KEY PROGRAM button to select an empty programming slot, or you can wait 4 seconds for the VCR to automatically select an empty slot.
- ③ You will see the "Program to record" screen. Press the ONE KEY PROGRAM button until the channel you would like to record (for example, channel 2) appears. Then, wait for 4 seconds. The cursor will move down to the next position, "Day." (If you are recording from a cable box that the VCR cannot control, set the channel to 3 or 4, whichever the cable box sends signals on.)

▷ **Important:** If you wish to record from an external source, press the ONE KEY PROGRAM button until "External 1" or "External 2" appears.

```

◆ Program to record
Channel 2
▶ Day Monday 19
  Start time ----
  Stop time ----
  Record speed AUTO

Select with O.K. PROGRAM,
then pause for 4 seconds

```

- ④ Press the ONE KEY PROGRAM button to choose the day you would like to record (for example, Monday the nineteenth). Then, wait for 4 seconds. The cursor will move to the starting time, and the hours will flash.

```

◆ Program to record
Channel 2
Day Monday 19
▶ Start time 11:00 AM
  Stop time ----
  Record speed AUTO

Select with O.K. PROGRAM,
then pause for 4 seconds

```

- ⑤ Press the ONE KEY PROGRAM button to choose the hour you wish recording to start. Then, wait for 4 seconds. The minute numbers will begin to flash.

```

◆ Program to record
Channel 2
Day Monday 19
▶ Start time 11:30 AM
  Stop time ----
  Record speed AUTO

Select with O.K. PROGRAM,
then pause for 4 seconds

```

- ⑥ Press the ONE KEY PROGRAM button to choose the minutes you wish recording to start. Then, wait for 4 seconds. The cursor will move to "Stop time."

```

◆ Program to record
Channel 2
Day Monday 19
Start time 11:30 AM
▶ Stop time 1:00 PM
  Record speed AUTO

Select with O.K. PROGRAM,
then pause for 4 seconds

```

- ⑦ Press the ONE KEY PROGRAM button to choose the hour you wish recording to stop. Then, wait for 4 seconds. The minute numbers will begin to flash.

```

◆ Program to record
Channel      2
Day         Monday 19
Start time   11:30 AM
▶ Stop time  1:30 PM
Record speed AUTO

Select with O.K.PROGRAM,
then pause for 4 seconds

```

```

◆ Program to record
Channel      2
Day         Monday 19
Start time   11:30 AM
Stop time    1:30 PM
▶ Record speed SP

Select with O.K.PROGRAM,
then pause for 4 seconds

```

- 8 Press the ONE KEY PROGRAM button to choose the minute you wish recording to stop. After 4 seconds, the cursor will move to "Record speed."
- 9 Press the ONE KEY PROGRAM button to set the recording speed. After 4 seconds, the menus will turn off.
- 10 When finished with all programming, press the POWER button to turn off the VCR, and make sure the programmed recording light (☐) is lit on the fluorescent display. If you are using a cable box, leave it turned on and tuned to the channel you wish to record. If you are using an A/B switch, remember to set the switch to the correct position.

The VCR is ready to record what you've programmed.

changing settings while programming

If you make a mistake when using ONE KEY PROGRAM:

- 1 Press the FF or REW buttons on the front panel or the ENTER or CANCEL buttons on the remote control to move the cursor next to the item you wish to change.
- 2 Once you have chosen a item, you can change it by using the PLAY or PAUSE buttons on the front panel, or the JOG/ADJUST buttons on the remote control.
- 3 Once you have corrected the setting, use the FF button or the ENTER button to resume your place.

▷ **Important:** If you press CANCEL or REW while the cursor is next to the channel number, you will cancel the entire program. If you want to stop One Key Programming, press STOP.

Using Quick Program

Quick Program is an exclusive Mitsubishi feature that simplifies the process of programming your VCR to record. When you press the QUICK PROGRAM button on the remote control, you will immediately see the "Program to record" menu and can begin programming right away. You can use this feature when the VCR is stopped, playing, recording, fast forwarding, rewinding, or off.

Quick Program is also an "Active A/V Network" feature. If you have a Mitsubishi TV with Active A/V Network, turn to page 56 for more information.

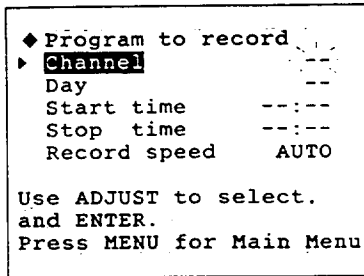

CH	DAY	ON	OFF
2	MO19	11:30 ^A	1:30 ^P SP
10	TH22	9:00 ^P	10:00 ^P EP
7	E-WE	8:00 ^A	9:00 ^A EP
29	FR23	5:30 ^P	5:45 ^P EP
8	TU27	11:00 ^P	0:30 ^A SP
33	M-F	7:00 ^P	7:15 ^P EP
15	SA 1	8:00 ^P	9:00 ^P EP
46	SU25	7:00 ^A	9:00 ^A SP

To use quick program:

- 1 Press the QUICK PROGRAM button on the remote control. If the VCR is off, it will turn on. After tuning your TV to the correct channel or input, you will see the "Program to record" screen (above left), unless the VCR's memory is full.

If the VCR's memory is full, you will see the recap screen (below left). You will need to use the CANCEL button to erase an entry before you can add another one.

- 2 Complete programming as described in "Programming Your VCR to Record." When you are finished, press the QUICK PROGRAM button again. If the VCR is stopped, it will turn off and be ready to record your program at a later time. If the VCR is playing, recording, fast forwarding or rewinding, the menus will turn off, but the VCR power will remain on. You will have to turn the power OFF yourself.

After the VCR power is turned OFF, be sure the programmed recording light (☐) is lit on the fluorescent display. However, if you have a cable box, leave the box turned ON, tuned to the station you wish to record. If you are using an A/B switch, remember to set the switch to the correct position.

▷ **Important:** If you press the QUICK PROGRAM button, but the clock is not set, you will see the "Set the clock" menu. If you set the "A/V Network" setting in the "Customize choices" menu, point the remote control towards the TV when using Quick Program.

The QUICK PROGRAM button does not work during One-Key Programming.

Notes about programmed recording

▷ **Important:** If you use the VCR when the programmed recording light (☐) is lit, you may interfere with a programmed recording. If you want to use the VCR before programmed recording begins, press the POWER button on the remote once. This turns the programmed recording light off and the VCR on. If you use the POWER button on the front panel for this purpose, you will have to press it twice. Pressing it once turns off the programmed recording light; pressing it a second time turns the VCR on.

When you are finished using the VCR, turn the VCR power off again, either with the POWER button on the remote or the POWER button on the front panel. Make sure the programmed recording light is back on.

After a program has been recorded, the VCR memory is cleared (unless you have scheduled the VCR to record the program every day or every week).

If there is already a program in the VCR's memory, you will see the "recap" screen when you bring up the menus for programming to record (unless you are programming with the QUICK PROGRAM button). If the VCR's memory is full, you will have to erase a program before you can enter a new one.

If a tape runs out during programmed recording, the VCR ejects the tape and the programmed recording light (☐) and the tape status symbol (○○○) will flash. Load a new tape and press the REC button. The VCR will resume recording.

Do not overlap the recording times you program.

- ▷ **Important:** Remember that when your VCR is off, it may also be in stand-by for programmed recording. Also remember that the VCR, when programmed, will record over the next section of tape. To avoid recording over tapes you want to save, remember that the VCR automatically shuts off during OTR recording and "rewind & off."

Your VCR will not record over a tape that has the erasure prevention tab removed (see "Preventing accidental erasure"). All rental movies have this tab removed, so they are safe from being accidentally erased.

auto speed programming

Use auto speed programming if you want to record as much of the program as possible is standard play (SP) speed, but you want the VCR to automatically switch to extended play (EP) if there is not enough tape left.

Auto speed programming is available in only one programming slot. In this first slot, the recording speed is set to AUTO automatically. If you want to use auto speed programming in this programming slot, you don't need to change anything.

- ▷ **Important:** Make sure that the "Tape" video function matches the kind of tape you are using. (See "Selecting and adjusting the audio and video functions" on page 26.)

Set the time for recording to end a minute or two beyond the program's scheduled broadcast time.

programming TV programs that end on the day after

If you want to start the recording at 11:00 PM and end it at 2:00 AM the next day, simply set the start time to 11:00 PM on the recording start day and the end time to 2:00 AM. There is no need to change the day of the week.

skipping programs

If you have already entered a program into your VCR's memory, you can skip the program without going into the VCR's menus. Simply press the POWER button on the front panel once. The programmed recording light (☐) will turn off, and the program will be skipped. If you decide not to skip the program, press the POWER button on the front panel twice; the programmed recording light will light up again.

changing programmed recording settings

If you want to change the programmed recording settings:

◆ Program to record			
CH	DAY	ON	OFF
2	MO19	11:30A	1:30P SP
10	TH22	9:00P	10:00P EP
▶	---	---	---
---	---	---	---

Use ADJUST to select,
and ENTER.
Press MENU for Main Menu

- 1 Turn the VCR on with the POWER button.
- 2 Press the MENU button on the remote control.
- 3 Press the JOG/ADJUST buttons to select "Program to record." Press ENTER. You'll see the "recap" screen.
- 4 Press the JOG/ADJUST buttons to place the cursor next to the program you wish to change. Press the ENTER button.
- 5 Press the ENTER button to place the cursor next to the item to be changed. Change it with the JOG/ADJUST buttons.
- 6 Use the MENU button to turn off the menus. Then, use the POWER button to turn off the VCR. Make sure the programmed recording light is on.

canceling a programmed recording

◆ Program to record			
CH	DAY	ON	OFF
2	MO19	11:30A	1:30P SP
10	TH22	9:00P	10:00P EP
▶	---	---	---
---	---	---	---

Use ADJUST to select,
and ENTER.
Press MENU for Main Menu

- 1 Use the POWER button to turn the VCR on.
- 2 Press the MENU button on the remote control. The "VCR Main Menu" appears on your screen. Use the JOG/ADJUST buttons on the remote control to move the cursor next to "Program to record." Press the ENTER button.
- 3 You will see the "recap" screen. Use the JOG/ADJUST buttons to place the cursor next to the program to be canceled.
- 4 Press the CANCEL button. The program is erased.
- 5 Press the MENU button once to return to the Main Menu; press it again to turn off the menus.

using the TIMER RESET button

You can use the TIMER RESET button on the rear panel to erase both the time and all programmed recordings.

To use the TIMER RESET button, press it with a pencil or a ball point pen. The power will turn off and the clock will reset. All programmed recording is erased. Additionally, the TIMER RESET button will reset the on-screen language you selected. The next time you use the menus, you will have to select the on-screen language. (See page 25.)

correcting programming errors

If, after programming, you forget to load a tape, or load a tape with its erasure tab removed, then the programmed recording light and the tape status symbol will flash. A tape without an erasure tab will be ejected. To correct this, load a tape with its erasure tab intact, and turn off the VCR.

memory backup

If the VCR is without power for 30 minutes or less, it will retain the time and the programmed settings, provided the VCR has been plugged in for at least an hour beforehand. If the power is out for more than 30 minutes the time and the programmed settings will be lost.



Now that you've learned about the basic operation of your VCR, you're ready to discover its advanced features. You'll find information on:

- ◆ Using the Advanced Playback Controls
- ◆ Using the Advanced Recording Controls
- ◆ Searching Techniques
- ◆ Using the Active A/V Network Features
- ◆ Making a Copy of a Tape
- ◆ Using Child Lock

Before you use the advanced features, you should be familiar with all of the VCR's basic operations, including viewing a picture coming from your VCR (page 22), playing back a tape (page 24), using the menus (page 28), and recording (page 33). If you find any of the information in this section confusing, you may want to review the previous chapters.

◆ Using the Advanced Playback Controls

In this section, you'll discover some of the advanced playback features of your VCR. These include:

- Using special effects,
- Adjusting the tracking, and
- Using the time counter.

Using special effects

You can use the FF, REW, and JOG/ADJUST buttons on the remote control to control the playback speed of the tape.

using the FF and REW buttons to control the playback speed

The FF and REW buttons control the playback speed in a step-by-step method.

- ① While the VCR is playing a tape, press the PAUSE button to freeze the picture on the screen.
- ② Press the FF or REW button. Each press of the FF button changes the playback speed by one step in the forward direction. Each press of the REW button changes the speed by one step in the reverse direction. (See the chart on the next page.)
- ③ To resume normal playback, press the PLAY button.

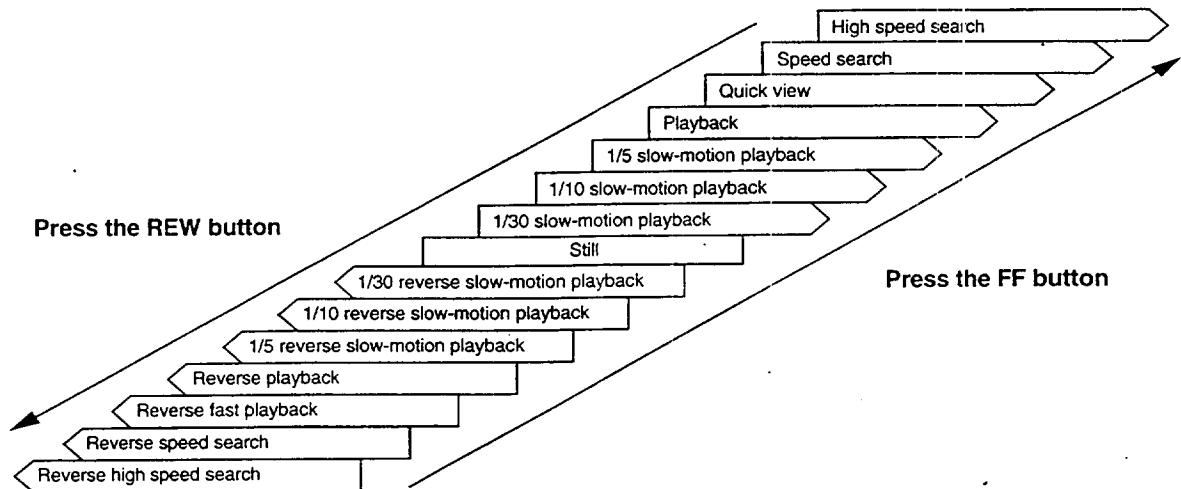

► **Important:** After about five minutes in the still or slow-motion mode, the VCR will automatically stop to avoid damage to the tape.

The picture may vibrate vertically, depending on the type of TV you have.

using the JOG/ADJUST buttons to control the playback speed

The JOG/ADJUST buttons allow you to advance the tape frame-by-frame.

- ❶ While the VCR is playing a tape, press the PAUSE button to freeze the picture on the screen.
- ❷ Press the JOG/ADJUST “+” button to advance forward one frame and the “-” button to back up one frame.
- ❸ To resume normal playback, press the PLAY button.

using still adjustment

Sometimes during still frame, the picture may vibrate or shake. To correct this problem, press the CHANNEL buttons on the front panel until the vibration is reduced or stops. (Side-to-side vibration cannot be corrected.)

Adjusting the tracking

automatic tracking

Your VCR automatically adjusts the tape to give you the best quality picture. When you press the PLAY button, the DIGITAL TRACKING light will flash, showing that the VCR is adjusting the picture. When the VCR has finished adjusting the picture, the DTR light will shine steadily.

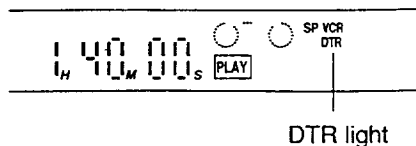

► **Important:** A certain amount of “noise” in the picture or sound is normal while the VCR is tracking a tape.

manual tracking

From time to time, you might play a tape that has excess “noise” in the picture (often looking like vibration or interference at the top or bottom of the screen). To correct the picture, you will have to manually track the tape.

- 1 While the tape is playing, press the CHANNEL buttons on the front panel until the picture is clear of excess “noise.”
- 2 To continue automatic tracking, press both of the CHANNEL buttons on the front panel at the same time. Automatic tracking will also resume when you eject the tape.

slow tracking

Slow tracking is used to adjust the playback quality during slow motion playback and still frame. You can only use slow tracking if your tape was recorded in extended play (EP) speed. To adjust the slow tracking, put a tape into slow motion, then press the CHANNEL button on the front panel of the VCR until the best picture is obtained.

Using the time counter

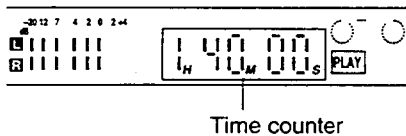

Your VCR has a time counter that shows the amount of time the tape has run in hours, minutes, and seconds. This counter is useful when you want to find specific points on a tape. The counter will not work with blank tapes, on blank sections of tape, or when the VCR's power is off.

setting the counter

To set the counter to “0H00M00s,” press the CANCEL button on the remote control. (You cannot reset the counter if the VCR's menus are in use.)

Your VCR will automatically reset the counter to “0H00M00s” when you load a tape into the VCR. It will also display “-H - - M - - s” when no tape is loaded in the VCR.

- ▷ **Important:** The counter cannot display times greater than “9H59M59s” in either the forward or reverse direction. If you are using a tape labeled T-210, the counter will not be displayed correctly when the tape runs longer than “9H59M59s.”

◆ Using the Advanced Recording Controls

In this section, you'll learn about some of the advanced recording features of your VCR, including:

- Using the PerfectTape™ feature,
- Displaying the time gauge and the remaining time, and
- Displaying the present time.

Using the PerfectTape™ feature

PerfectTape™ is an exclusive Mitsubishi feature that tests the quality of your video tapes. After each test, the VCR will adjust its internal circuitry in order to make the best possible recording on your tape.

setting up PerfectTape™

You have the option of setting PerfectTape™ to function only when you initiate a test, or to automatically function every time you insert a tape that has not yet been recorded. To do this:

- ① Press the MENU button on the remote control to display the "VCR Main Menu." Use the JOG/ADJUST buttons on the remote control to move the cursor next to "First Time Set-Up." Press the ENTER button.
- ② The "First Time Set-Up" menu will appear. Use the JOG/ADJUST buttons to move the cursor next to "Customize choices" and press the ENTER button.
- ③ The "Customize choices" menu will appear. The cursor will be next to the "PerfectTape" option.
- ④ Press the ENTER button to set "PerfectTape" to AUTO or MANUAL.
- ⑤ Press the MENU button three times to turn off the menus.

```

◆ First Time Set-Up
Your choices are:
  Set the clock
  ▶ Customize choices
  Memorize channels
  Add/delete channels

Use ADJUST to select,
and ENTER.
Press MENU for Main Menu
  
```

```

Customize choices
▶ PerfectTape (AUTO)
Video mute (ON)
A/V Network (OFF)

Use ADJUST to select,
and ENTER to change
settings. Press
MENU for Set-Up Menu
  
```

If you set PerfectTape™ to AUTO, the VCR will automatically test any non-recorded tapes you place in the VCR. It will not automatically test pre-recorded tapes -- you must choose to test those yourself.

If you set PerfectTape™ to MANUAL, the VCR will not automatically test any tapes. PerfectTape will only function when you initiate a test.

using PerfectTape™ automatically

Before you begin, you need to:

- have set "PerfectTape" to "AUTO" in the "Customize choices" menu.

- ① Load a tape that has not been recorded into the VCR.

The VCR will display the testing status screen. When testing, the VCR records for one second, then evaluates the recording it made. The entire test takes about eight seconds. During this time, the "PT" light on the front panel will flash. If you wish to cancel the test, press the STOP button while the "PT" light is flashing.

```

          PerfectTape
Band
High  ██████████
Mid.  ██████████
Low   ██████████
Testing the tape....
  
```

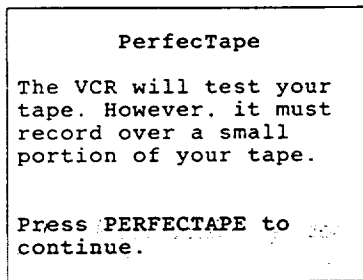
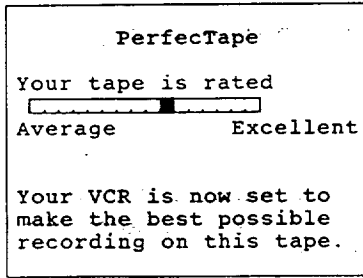

When the test is finished, the VCR will display the rating of your tape for eight seconds. On the front panel, the "PT" light will shine steadily, indicating that the VCR has set its internal circuitry to make the best possible recording on this tape.

using PerfectTape™ manually

- ① Load a tape that has its erasure tab intact into the VCR.
- ② Find a portion of the tape that is OK to record over; the PerfectTape™ feature will record over approximately one second of your tape.
- ③ Press the PERFECTAPE button on the front panel. You will see the PerfectTape™ explanation screen.
- ④ Press the PERFECTAPE button again to begin the test.

The VCR will display the testing status screen. When testing, the VCR records for one second, then evaluates the recording it made. The test takes about eight seconds. During this time, the "PT" light on the front panel will flash. To cancel the test, press the STOP button while the "PT" light is flashing.

When the test is finished, the VCR will display the rating of your tape for eight seconds. On the front panel, the "PT" light will shine steadily, indicating that the VCR has set its internal circuitry to make the best recording on the tape. You can quickly turn off the display by pressing the STOP button or the PERFECTAPE button.

If you would like to record without the settings that resulted from the test, press the PERFECTAPE button to turn off the PT light on the fluorescent display. If you would like to restore the settings, press the PERFECTAPE button to turn the PT light back on. Should you wish to erase the PerfectTape™ settings, eject the tape. The settings will also be erased if you press the TIMER RESET button, or if the VCR loses power.

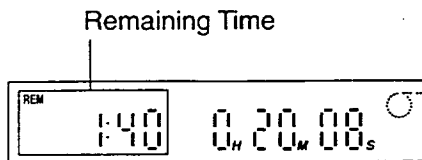

Displaying the time gauge and the remaining time

The time gauge is a graphic representation of your position on a video tape. The left side of the gauge is the start (S) of the tape, and the right side is the end (E) of the tape. For a T-120 length tape, played at standard (SP) speed, each mark on the gauge represents about 15 minutes. The tape remaining display shows the time, in hours and minutes, left until the end of a tape.

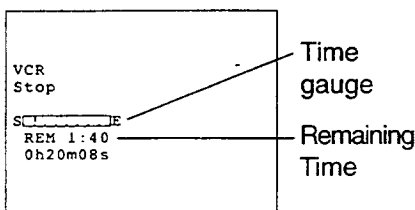

The time gauge and the remaining time automatically appear: during fast forward and rewind (from a stopped tape), during timed searches, index searches, when rewinding for repeat playback, during skip search, and during searches for blank sections of tape.

You can turn off the time gauge and the remaining time by pressing the DISPLAY button twice.

To make the time gauge and the remaining time appear:

Press the DISPLAY button once. The time gauge and remaining time will appear on the TV screen, and the remaining time will appear on the fluorescent display. They will disappear after four seconds during playback. To turn off the display, press the DISPLAY button twice.

▷ **Important:** The time gauge and remaining time work by detecting control signals on recorded tapes. They will therefore not function with tapes that have not yet been recorded. Also, you must have set the "Tape" video function correctly.

Depending on the length of the tape being used, it may take a moment for the display to appear.

The tape remaining display may not show the correct remaining time if the tape function is incorrectly set (see "Using the Audio and Video Functions" on page 26), if you are using speed search, if you are using a special length cassette (such as T-10 length or T-210 length), or if you are using a cassette with an adapter.

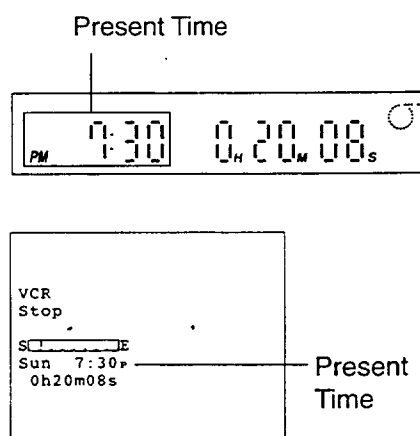

Displaying the present time

The present time display on the fluorescent display panel or on the TV screen shows the current time. If you have not set the clock, or if there has been a power failure of more than 30 minutes, the display will show -- -. The current time will be displayed when the VCR is off. To see the current time when the VCR is on:

- ① Press the DISPLAY button on the remote control twice. The peak level meter will be replaced by the present time.
- ② To turn off the present time, press DISPLAY once.

◆ Searching Techniques

The VCR lets you search through a tape in a number of ways. These include:

- Edit searching,
- Speed searching,
- Searching by time,
- Searching for a blank portion of tape, and
- Index search techniques.

Edit searching

Edit search is very useful for editing out commercials if you are recording a program while you are watching it. It is also useful as a general editing feature. This feature is sometimes called EE (electronic-to-electronic) editing. This function works only when you are in "record-pause" mode.

- ① During record pause, press the FF or REW button on the remote control or on the front panel to locate the point where you want to resume recording.
- ② When you find the point where you want to continue recording (e.g. the last frame before the commercial), stop operating the buttons. After 3 seconds, the VCR will return to record pause; you will see the live picture.
- ③ Press the PAUSE button (NOT the REC button) to resume recording (when the commercials are over).

▷ **Important:** Edit search will begin any time you are in record-pause and operate the REW or FF buttons. Edit search will end after 3 seconds of not using the buttons.

Speed searching

You can use speed search to visually search through the contents of a videotape. To do this:

- ① While playing a tape, press FF or REW button. You will see the picture as it fast forwards or rewinds. It is normal to see some "noise bars."
- ② If you press the FF or REW and hold it down for about 1 second, the search speed will increase.
- ③ To resume normal playback, press FF or REW again quickly, or press PLAY.

▷ **Important:** The fastest search speed that allows you to see the picture is about 30 times normal speed. Using fast forward or rewind without the picture allows you to search up to 200 times normal speed. The fastest way to move through the tape is without a picture. It is normal for the number of noise bars on the screen to increase and roll from top to bottom as the search speed increases.

spot check

This feature allows you to visually check the position of the tape during fast forward or rewind.

- ① While the tape is in fast forward or rewind (without picture), press and hold either the FF or REW button (whichever is the same as what the tape is doing).

- ② After a short delay, you will see the contents of the videotape, still in speed search. The picture will stay on the screen as long as you hold down the button.
- ③ When you release the button, the tape will resume fast forwarding or rewinding without a picture.

Searching by time

You can use the time counter to search to a specific point on a tape. You can search in one of two ways:

- You can search to a certain point, measured from the beginning of the tape.
- You can search to a certain point, measure from the current position on the tape. (You cannot search further than “9h59m59s” in either direction.)

```

VCR Main Menu
Your choices are:
  Program to record
  Advanced Features
▶ Search by time
  First Time Set-Up

Use ADJUST to select,
and ENTER.
Press MENU to exit menus

```

To search for a point measured from the beginning of the tape:

- ① Press the MENU button on the remote control to display the “VCR Main Menu.”
- ② Use the JOG/ADJUST buttons to move the cursor next to “Search by time.” Press the ENTER button.

▷ **Important:** If there is no tape loaded in the VCR, or if the VCR is recording, then the words “Not available” will flash and you will see an error message. Load a tape into the VCR or stop recording.

```

◆ Search by time

Rewind to top and
Search to → 0h30m00s

VCR will search to the
time you select.
Use ADJUST to select,
and ENTER.
Press MENU for Main Menu

```

- ③ You will see the “Search by time” menu. Use the JOG/ADJUST buttons to set the point on the tape (measured from the beginning) to which you want to search, in hours and minutes. Hold the buttons down to set the hour and minutes in 10-minute intervals. Press the buttons repeatedly to set single minutes. You can also use the number buttons to set the time in hours, minutes, and seconds. Press CANCEL to clear the time you have entered.

▷ **Important:** If the elapsed time counter has been reset, the display you will see will not match the one shown in step ③. If this is the case, eject the tape and reinsert it, then repeat steps ① through ③.

- ④ Press the ENTER button. (If you used the number buttons, you do not need to do this.) The VCR will rewind to the beginning of the tape, reset the counter to 0h00m00s, fast forward to the point you selected and begin playing.
- ⑤ Press PLAY or STOP to cancel the time search.

To search to a point, measured from the current tape position:

- ① Before entering the menus, press the CANCEL button to reset the counter to “0h00m00s.”

◆ Search by time

Now at Search to
0h00m00s → 0h30m00s

VCR will search to the time you select. Use ADJUST to select, and ENTER. Press MENU for Main Menu

- ② Follow the instructions ① through ③ above. You will see the display at the left.
- ③ Press ENTER. The VCR will fast forward or rewind to the point you select.

To search to another point on the same tape, you don't need to press the CANCEL button in step ①.

▷ **Important:** If the VCR reaches the end of the tape before finding the point you've chosen, the search is canceled; if the VCR has reached the beginning of the tape, it will begin playback. The tape may not search to the exact point you have chosen.

▲ VCR Main Menu

Your choices are:

- Program to record
- ▶ **Advanced Features**
- Search by time
- First Time Set-Up

Use ADJUST to select, and ENTER. Press MENU to exit menus

Searching for a blank portion of tape

Use "Search to blank" to find any blank portion of a tape.

- ① Press the MENU button on the remote control to display the "VCR Main Menu."
- ② Use the JOG/ADJUST buttons to move the cursor next to "Advanced Features." Press the ENTER button. ("Advanced Features" are not available if there is no tape in the VCR, or if the VCR is recording.)
- ③ The "Advanced Features" menu will appear on your screen. The cursor will be next to "Search to blank". Press the ENTER button. The VCR will fast forward and stop at the first blank (unrecorded) section of tape. If the VCR reaches the end of the tape, the search is canceled.

◆ Advanced Features

Your choices are:

- ▶ **Search to blank**
- Repeat play
- Erase index mark
- Skip search

Use ADJUST to select, and ENTER. Press MENU for Main Menu

▷ **Important:** If there is no tape loaded in the VCR, or if the VCR is recording, you will see an error message, indicating that this feature is not available. Load a tape into the VCR or stop recording.

Index search techniques

Index search is a very useful way to find specific points on a tape. Index search works by placing index marks at important places on a tape. Then, you use index search to find these marks. Index marks are added automatically whenever your VCR starts a new recording; you can also add index marks manually at any spot.

automatic index marks

Whenever recording is begun from the STOP mode, an index mark is automatically added to the tape. The index light (▼) will flash on the fluorescent display, and an on-screen message will indicate that the mark is being recorded.

▷ **Important:** Index marks are not added when you press PAUSE to begin recording from the record-pause mode.

manual index marks

To add an index mark yourself, press the REC button on the remote control while a tape is recording or playing.

- ▷ **Important:** Index marks must be added at least one minute apart. You cannot add an index mark to a tape with its erasure tab removed. When you add an index mark to a playing tape, the sound on the mono track will turn off.

To search for an index mark:

```
VCR Looking
for index+ 1
-----E
REM 1:40
0h20m08s
```

```
VCR Looking
for index- 1
-----E
REM 1:40
0h20m08s
```

- 1 Press the INDEX SEARCH “+” button on the remote control to begin a forward search; press INDEX SEARCH “-” to begin a search in the reverse direction. The VCR will fast forward or rewind, and one of two screens will be displayed on the TV. Once the VCR finds an index mark, it will begin playback from that point. You cannot begin a search from still frame.
- 2 You can press the plus (+) or minus (-) buttons up to 19 times to search for that many index marks. For example, to find the third index mark ahead, press the plus (+) button three times. The on-screen display will count down the number of marks to be passed before playback begins.
- 3 To cancel index search, press PLAY or STOP.

erasing index marks

```
◆ Advanced Features
Your choices are:
Search to blank
Repeat play
▶ Erase index mark
Skip search

Use ADJUST to select,
and ENTER.
Press MENU for Main Menu
```

- 1 Make sure the video mute function is on. (See “Using video mute” on page 31.)
- 2 Press the MENU button on the remote control. The “VCR Main Menu” will appear on your screen.
- 3 Use the JOG/ADJUST buttons to move the cursor next to “Advanced Features.” Press ENTER. (“Advanced Features” are not available if there is no tape in the VCR, or if the VCR is recording.)
- 4 The “Advanced Features” menu will appear on your screen. Use the JOG/ADJUST buttons to move the cursor next to “Erase index mark.” Then, press ENTER.

- ▷ **Important:** If there is no tape loaded in the VCR, if the VCR is recording, or if the tape has had its erasure tab removed, you will see an error message indicating that this feature is not available. Load a tape into the VCR, stop recording, or place a piece of tape over the erasure tab to correct this.

```
Erase index mark

Find the section that
includes the index mark
you would like to erase.
Press PLAY,
then press REC
before the index mark.

Press MENU for Main Menu
```

- 5 You will see the “Erase index mark” menu (left). Without exiting the menus, use the INDEX SEARCH buttons to find the index mark you wish to erase.

- ⑥ When the index mark has been located, and playback has begun, press STOP.
- ⑦ Rewind the tape for a few seconds, then press STOP.
- ⑧ Press the PLAY button, then the REC button on the remote control. The index light (▼) on the fluorescent display will light up. When the index mark is found, the index light (▼) will flash, and the mark will be erased.
- ⑨ When the index mark has been erased, press STOP.

▷ **Important:** When you erase an index mark from a tape, you cannot hear the sound on the mono track.

using repeat playback

You can play back a section of tape over and over using the following procedure. The tape will play until the next index mark, rewind to the previous index mark, and resume playing. If there is only one index mark on the tape, then the VCR will play or rewind to that mark and resume playback. If there is no index mark, the entire cassette will repeat.

```

▲ VCR Main Menu
Your choices are:
  Program to record
  ▶ Advanced Features
  Search by time
  First Time Set-Up

Use ADJUST to select,
and ENTER.
Press MENU to exit menus
  
```

```

◆ Advanced Features
Your choices are:
  Search to blank
  ▶ Repeat play
  Erase index mark
  Skip search

Use ADJUST to select,
and ENTER.
Press MENU for Main Menu
  
```

- ① Press the MENU button on the remote control. The "VCR Main Menu" will appear on your screen. Use the JOG/ADJUST buttons to select "Advanced Features." Press ENTER. ("Advanced Features" are not available if there is no tape in the VCR, or if the VCR is recording.)

- ② The "Advanced Features" menu will appear on the screen. Use the JOG/ADJUST buttons on the remote control to move the cursor next to "Repeat play." Press ENTER.

When the VCR encounters the next marker (or the end of the tape), it will automatically rewind to the previous mark and begin playback.

▷ **Important:** If there is no tape loaded in the VCR, or if the VCR is recording, you will see an error message indicating that this feature is not available. Load a tape into the VCR or stop recording.

- ③ Press the STOP button to cancel repeating.

skip search

When you use skip search, the VCR will fast forward or rewind (without picture) through the tape, showing you short sections of the tape wherever it finds an index mark. Skip search only works if there are index marks recorded on the tape.

```

▲ VCR Main Menu
Your choices are:
  Program to record
  ▶ Advanced Features
  Search by time
  First Time Set-Up

Use ADJUST to select,
and ENTER.
Press MENU to exit menus
  
```

- ① Press the MENU button on the remote control. The "VCR Main Menu" will appear on your screen. Use the JOG/ADJUST buttons to select "Advanced Features." Press ENTER. ("Advanced Features" are not available if there is no tape in the VCR, or if the VCR is recording.)

```

◆ Advanced Features
Your choices are:
  Search to blank
  Repeat play
  Erase index mark
▶ Skip search

Use ADJUST to select,
and ENTER.
Press MENU for Main Menu

```

- ② The “Advanced Features” menu will appear on the screen. Use the JOG/ADJUST buttons on the remote control to move the cursor next to “Skip search.” Press the ENTER button.

The VCR will fast forward until it finds an index mark. Then, it will show the tape in visual forward speed search for about five seconds. Then it will fast forward again, looking for the next index mark.

▷ **Important:** If there is no tape loaded in the VCR, or if the VCR is recording, you will see an error message indicating that this feature is not available. Load a tape into the VCR or stop recording.

- ③ Press PLAY when you see the section you are looking for.
- ④ Press REW to reverse the direction of the skip search.
- ⑤ Press STOP or PLAY to cancel skip search.

▷ **Important:** Skip search will only find index marks recorded more than three minutes apart in the forward direction; skip search will only find index marks recorded at least ten minutes apart in the reverse direction.

◆ Using the Active A/V Network Features

The Active A/V Network is a benefit of certain Mitsubishi TVs and VCRs. The Active A/V Network allows you to use many of the commonly used features of your system at the press of one button.

Before you begin:

- your VCR must be connected to External 1 (EXT-1) of a Mitsubishi TV with Active A/V Network;
- you must have turned on video mute (page 31);
- you must have turned on the Active A/V Network setting on your TV;
- you must have connected a cable from the Active A/V Network OUT terminal of the TV to the Active A/V Network IN terminal of the VCR (page 17).

To turn on the Active A/V Network on your VCR:

- ① Press the MENU button on the remote control. The “VCR Main Menu” appears on your TV.
- ② Use the JOG/ADJUST buttons on the remote to move the cursor next to “First Time Set-Up.” Press ENTER.
- ③ The “First Time Set-Up” menu appears on your screen. Use the JOG/ADJUST buttons to move the cursor next to “Customize choices.” Press the ENTER button.

```

▲ VCR Main Menu
Your choices are:
  Program to record
  Advanced Features
  Search by time
▶ First Time Set-Up

Use ADJUST to select,
and ENTER.
Press MENU to exit menus

```

```

◆ First Time Set-Up
Your choices are:
  Set the clock
▶ Customize choices
  Memorize channels
  Add/delete channels

Use ADJUST to select,
and ENTER.
Press MENU for Main Menu

```

```

Customize choices
PerfectTape      (AUTO)
Video mute      (ON )
▶A/V Network    (ACTIVE)

```

```

Use ADJUST to select,
and ENTER to change
settings. Press
MENU for Set-Up Menu

```

- ④ Use the JOG/ADJUST buttons to select "A/V Network."
- ⑤ Press the ENTER button to set "A/V Network" to ACTIVE.
- ⑥ Press the MENU button three times to turn off the menus.

what the Active A/V Network does

The Active A/V Network makes it easier and faster to use the VCR's Quick Program and Play commands.

When you press QUICK PROGRAM to begin programming:

- Active A/V Network will turn on your VCR and bring it to the "Program to record" Screen.
- Active A/V Network will turn on your TV (if it is off), and switch the TV to EXT-1.

When you press QUICK PROGRAM to end programming

- Active A/V Network will turn off your VCR (unless a tape is currently playing or recording).
- Active A/V Network will return your TV to the channel it was on before, or turn it off (if it was off originally).

When you press PLAY on the remote:

- Active A/V Network will turn your VCR on and begin playing the tape.
- Active A/V Network will turn the TV on, set to EXT-1.

When you turn your TV off:

- Your VCR will turn off, unless it is playing or recording.

Active A/V Network also affects your VCR when your TV's P.I.P. function is used. Active A/V Network can set your VCR's clock if your TV is equipped with the "StarSight" feature. See your TV Owner's Guide for more information.

▷ **Important:** When using the Active A/V Network, you should always point your remote control at your television, not your VCR.

◆ Making a Copy of a Tape

There are two basic ways to make a copy of a tape. One way is to use the HS-U510 to play a tape and use another VCR to record. The other way is to use another VCR to play a tape and the HS-U510 to record.

Whichever method you choose, you will need one RCA audio and one RCA video cable to connect the two VCRs. If you do not have these cables, they are available at your local electronics retailer. And remember, it is illegal to make copies of copyrighted material. In this section you'll learn:

- Using your HS-U510 to record from another VCR, and
- Using your HS-U510 to play back to another VCR.

Using your HS-U510 to record from another VCR

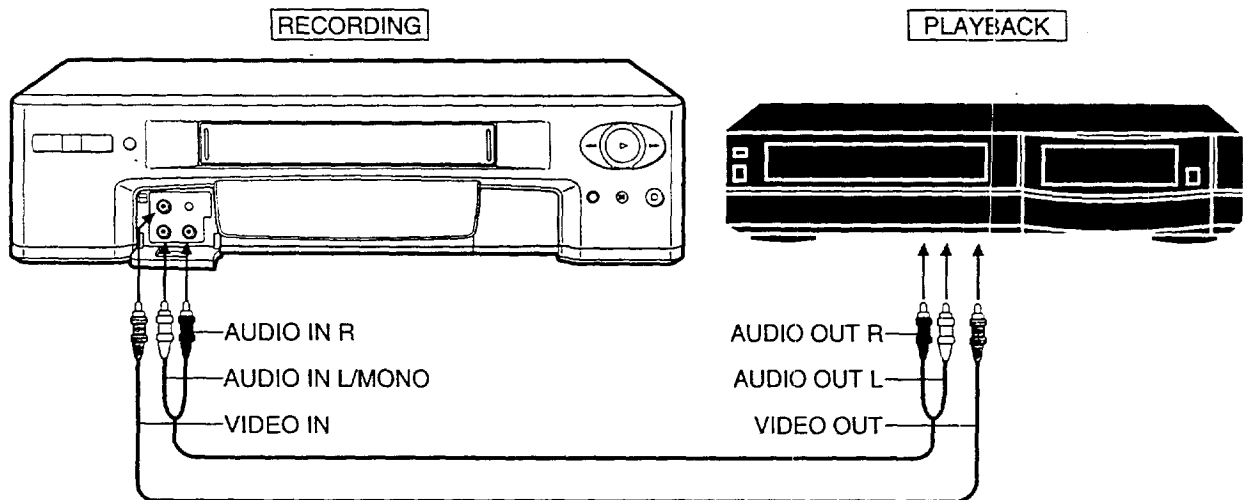

- 1 Connect one RCA audio cable to the AUDIO OUTPUT terminal on the other VCR. Connect the other end of this cable to the AUDIO INPUT terminal on the HS-U510 labeled L/MONO. If the other VCR is mono, this is the only audio connection necessary.
- 2 If the other VCR has stereo outputs, connect another RCA audio cable to the AUDIO OUTPUT terminal of the playback VCR. Connect the other end of this cable to the AUDIO INPUT terminal on the HS-U510 (labeled R).
- 3 Connect a video cable to the VIDEO OUTPUT terminal on the playback VCR. Connect the other end of this cable to the VIDEO INPUT terminal on the HS-U510 (labeled VIDEO IN 2).
- 4 If the other VCR is a Hi-Fi deck, set the audio monitor to "STEREO."
- 5 If you attached the connection cables to the back of the HS-U510, use the INPUT button to set the HS-U510 to External 1 (L1). If you attached the connection cables to the front of the HS-U510, use the INPUT button to set the HS-U510 to External 2 (L2).
- 6 Put a blank tape into the HS-U510 and find the place where you want to begin recording. Press STOP.
- 7 Put the tape you want to copy into the other VCR and find the place from which you want to begin copying. Press STOP.
- 8 On the HS-U510, press REC, then PAUSE.
- 9 On the other VCR, press PLAY, then PAUSE.
- 10 Release the PAUSE button on both VCRs at the same time.
- 11 When finished, press STOP on both VCRs.

Using your HS-U510 to play back to another VCR

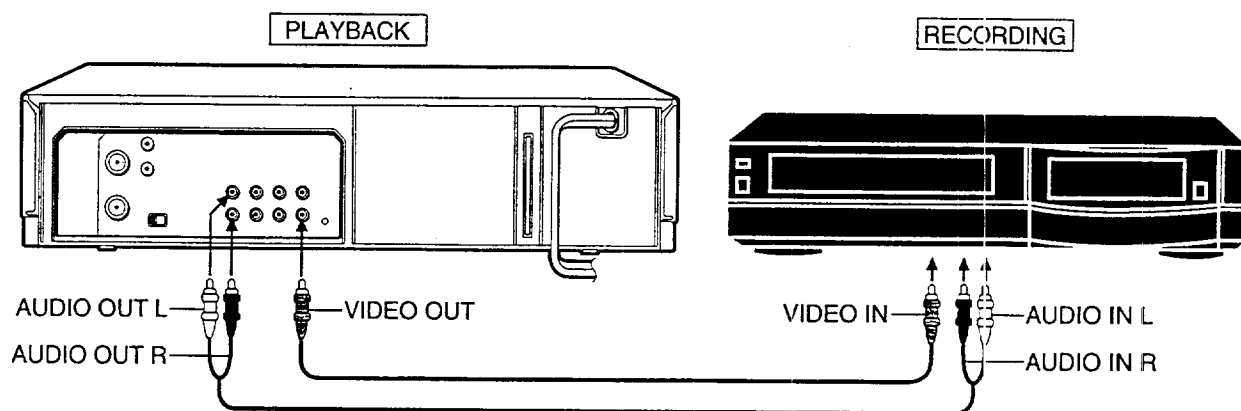

- 1 Connect one RCA audio cable to the AUDIO INPUT terminal on the other VCR. Connect the other end of this cable to the AUDIO OUTPUT terminal on the HS-U510 labeled L. If the other VCR is mono, you need a Y-adaptor to hear audio on both channels.
- 2 If the other VCR has stereo inputs, connect another RCA audio cable to the AUDIO INPUT terminal of the other VCR. Connect the other end of this cable to the HS-U510 AUDIO OUTPUT terminal labeled R.
- 3 Connect a video cable to the VIDEO INPUT terminal on the other VCR. Connect the other end of this cable to the VIDEO OUTPUT terminal on the HS-U510 labeled VIDEO OUT.
- 4 Set the audio monitor on the HS-U510 to "STEREO." (See page 26.)
- 5 Set the input of the other VCR to "External."
- 6 Put a blank tape into the other VCR and find the place where you want to begin recording. Press STOP.
- 7 Put the tape you want to copy into the HS-U510 and find the place from which you want to begin copying. Press STOP.
- 8 On the other VCR, press record (REC), and then PAUSE.
- 9 On the HS-U510, press PLAY, then PAUSE.
- 10 Release the PAUSE button on both VCRs at the same time.
- 11 When finished, press STOP on both VCRs.

◆ Using Child Lock

The child lock feature prevents others from using your VCR. To lock the VCR:

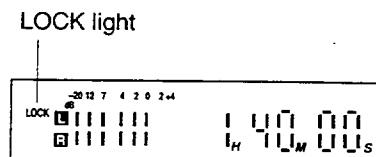

- 1 Press and hold down the DISPLAY button on the remote control for about 8 seconds. The LOCK light on the fluorescent display will light up.
- 2 To cancel the child lock, press and hold down the DISPLAY button for about 8 seconds, until the LOCK light on the fluorescent display goes out.

▷ **Important:** You can lock the VCR with the power off, even if the VCR is standing by for a programmed recording. If you lock the VCR with no cassette in it, the VCR will not accept a cassette.



CHAPTER FIVE Troubleshooting

Problems	Possible Solutions	For More Information
The VCR won't turn on.	<ul style="list-style-type: none">• Check the AC cord and the AC outlet.• Is the LOCK light ON? If so, press and hold the DISPLAY button for more than 8 seconds until the LOCK light disappears.	See Chapter 1, "Getting to Know Your VCR".
The VCR power is on but no controls work.	<ul style="list-style-type: none">• Press the TIMER RESET button.• Is the LOCK light ON? If so, press and hold the DISPLAY button for more than 8 seconds until the LOCK light disappears.	See Chapter 1, "Getting to Know Your VCR".
You can't see the VCR's picture on your TV.	<ul style="list-style-type: none">• Check the TV's input setting.• Check to see that your VCR is not set to "L1" or "L2."	See Chapter 3, "Operating Your VCR".
Poor picture when watching the VCR's tuner on your TV.	<ul style="list-style-type: none">• Check the VIDEO CHANNEL setting on the back of your VCR.• Check your TV's fine tuning.	See Chapter 3, "Operating Your VCR".
VCR REC button doesn't function.	<ul style="list-style-type: none">• Check the erasure prevention tab on the cassette.	See Chapter 3, "Operating Your VCR".
No picture during recording.	<ul style="list-style-type: none">• Check the hook-up.• Check to see if your TV is set to the correct channel or input.	See Chapter 2, "Connecting Your VCR" or Chapter 3, "Operating Your VCR".
VCR does not record TV.	<ul style="list-style-type: none">• Check the VCR tuning.• Check the input selection on the VCR. Does the front panel display show "L1" or "L2"? If so, you must switch it to tuner by pressing the INPUT button.	See Chapter 3, "Operating Your VCR".
The VCR timer recording does not operate.	<ul style="list-style-type: none">• Check that the programmed recording light lights up on the fluorescent display.• Check the clock time.	See Chapter 3, "Operating Your VCR".
Noise in the picture and distorted sound.	<ul style="list-style-type: none">• Check the tracking control. Adjust manually if necessary.	See Chapter 4, "Using the Advanced Features".
Poor or no Hi-Fi sound.	<ul style="list-style-type: none">• Check the monitor settings.• Check the quality of the video tape.	See Chapter 3, "Operating Your VCR".
Playback is noisy or "snowy".	<ul style="list-style-type: none">• Try automatic head cleaning.• Have your VCR video heads cleaned by a qualified service technician.	See Chapter 3, "Operating Your VCR".
VCR remote does not function.	<ul style="list-style-type: none">• Press the VCR button on the remote control before operating your VCR.• Press the TV button on the remote control before operating your TV.	See Chapter 3, "Operating Your VCR".

A		
A/B switch	12	
A/V Network		
Active features	56	
connecting	17	
connecting Active	18	
terminals	10	
adding channels	32	
adjust buttons	9	
antenna terminals	10	
antenna, connecting	11	
AUDIO/VIDEO button	9	
audio		
connecting TV with		
inputs	16	
functions	26	
input 2 terminals	6	
input and output		
terminals	10	
monitor	27	
B		
back panel	10	
backup, memory	44	
batteries	20	
blank, search for	53	
buttons, front panel	6	
C		
cable box, connecting	12	
cable tuning light	8	
cable, connecting	11	
cancel button	9	
canceling recording		
settings	43	
cassette slot	6	
changing recording		
settings	43	
channel buttons	7, 9	
channel display	8	
channels		
adding	32	
deleting	32	
programming the VCR		
to receive	30	
selecting	33	
child lock	59	
cleaning, head	24	
clock, setting	28	
connecting		
A/V Network	17	
Active A/V Network	18	
antenna	11, 13, 14	
cable	11	
cable box	12	
television	15	
UHF/VHF	14	
VCR	11	
copying tapes	57	
counter display	7	
counter, time	47	
D		
Daylight Savings Time	29	
deleting channels	32	
digital tracking light (DTR) ..	8	
display button	9	
display, counter	7	
display, fluorescent	7	
E		
edit search	51	
eject button	6	
enter button	9	
EP	8, 28	
erasure, preventing	24	
español	25	
F		
fast forward button	6, 10	
fast forwarding	25	
fluorescent display	7	
français	25	
Front Panel Buttons and		
Functions	6	
function button	9	
H		
head cleaning	24	
I		
Important Safeguards	2	
index		
erasing marks	54	
light	8	
marks	53	
search	53	
search button	9	
input button	6, 8	
installing batteries	20	
J		
jog buttons	9	
L		
L+R	27	
language, setting	25	
level meters	28	
loading tapes	23	
lock light	7	
lock, child	59	
LP	8, 28	
M		
memorizing channels	30	
memory backup	44	
menu button	10	
menus, using	28	
meters, level	28	
monitor television	20, 23	
monitor, audio	27	
mute button	9	
mute, video	31	
N		
normal recording	27	
notes about programmed		
recording	41	
number buttons	8	
O		
on-screen language,		
setting	25	
One Key Programming	38	
one key program button	7	
One-Touch Recording	37	
operating your VCR	19	
OTR	37	
P		
pause button	7, 9	
pausing	25	
Perfectape		
button	6	
feature	48	
light	8	

Index

picture, viewing the one
 from your VCR 22
play button 6, 9
play light 8
playing a tape 24
power button 6, 8
programmed recording
 light 7
programming
 changing while 37, 40
 one key 38
 the VCR to receive
 channels 30
 your VCR to record 35

Q

quick program
 button 9
 using 40
 with A/V Network 57

R

rear panel 10
record button (REC/OTR) 7
record button 9
record cancel 34
record light 8
record speed 28
recording 33
 current broadcast 34
 normal 27
 notes about 41
 One-Touch 37
 programming your VCR .. 35
remain light 7
remaining time 49
remote control
 batteries 20
 overview 8
 sensor 6
 using 20
repaired tapes 24
repeat playback 55
rewind button 6, 9
rewinding 25

S

Safeguards, Important 2
SAP 27
SAP indicator 8

search
 edit 51
 index 53
 skip 55
 speed 51
 time 52
 to blank 53
searching techniques 50
setting the time 28
setting up your VCR 19
skip search 55
skipping programs 43
slow motion 46
SP 8, 28
special effects 45
speed search 51
speed, record 28
splitter 15
spot check 51
stereo indicator 8
stop button 7, 10

T

tape speed light 8
tape status symbol 7
tape
 copying 57
 function 28
 loading and unloading 23
 playing 24
 repaired 24
television
 connecting 15
 monitor 20, 23
 using remote with 21
terminals, back panel 10
time
 counter 47
 gauge 49
 present 50
 remaining 49
 search 52
 setting 28
timer reset button 10
timer reset button, using ... 44
tracking 46
TV button 8

U

UHF/VHF, connecting 14

unloading tapes 24
Unpacking your VCR 5

V

VCR/TV button 10
VCR
 button 9
 connecting 11
 light 8
 operating 19
 setting up 19
 unpacking 5
 using remote with 20
 viewing picture 22
vibration, controlling 25
video channel switch 10, 19
video
 connecting TV with
 inputs 16
 functions 26
 input 2 terminal 6
 input and output
 terminals 10
 mute 31
viewing the picture from
 your VCR 22
volume button 9



Guía de Operación Básica de la Videgrabadora

Funciones básicas de los botones

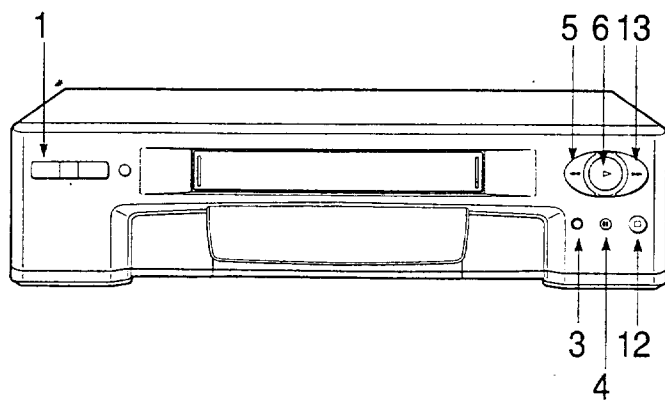
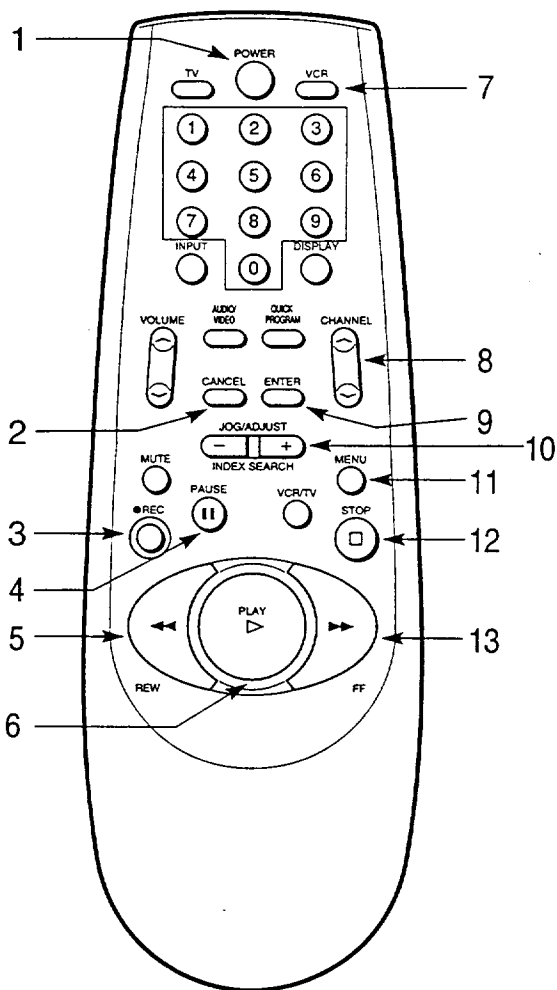

- ① **botón de encendido (POWER)**
Oprima este botón para encender y apagar la videgrabadora.
- ② **botón de cancelación (CANCEL)**
Utilice este botón para cancelar selecciones en los menús en pantalla.
- ③ **botón de grabación (REC, REC/OTR)**
Utilice este botón para comenzar la grabación.
- ④ **botón de pausa (PAUSE)**
Utilice este botón para pausar una cinta.
- ⑤ **botón de rebobinado (REW)**
Utilice este botón para rebobinar una cinta.
- ⑥ **botón de reproducción (PLAY)**
Utilice este botón para comenzar la reproducción de una cinta.
- ⑦ **botón de modalidad VCR (VCR)**
Oprima este botón para usar el control remoto para controlar la videgrabadora.
- ⑧ **botón de canales (CHANNEL)**
Oprima estos botones para cambiar canales en la videgrabadora.
- ⑨ **botón de ingreso (ENTER)**
Utilice este botón para ingresar selecciones en los menús en pantalla.
- ⑩ **botones de ajuste (JOG/ADJUST)**
Oprima estos botones para ajustar selecciones en los menús en pantalla.
- ⑪ **botón de menú (MENU)**
Oprima este botón para utilizar el sistema operativo de menús en pantalla.
- ⑫ **botón de parada (STOP)**
Oprima este botón para detener la reproducción o grabación de una cinta.
- ⑬ **botón de adelantado (FF)**
Oprima este botón para adelantar una cinta.

Cómo seleccionar el idioma de el sistema operativo de menús en pantalla

```
Select Language
English
▶ Español
Français

Use ADJUST to select.
and ENTER.
```

```
▲ Menú Principal
Sus selecciones son:
Programar grabaciones
Funciones Avanzadas
Búsqueda por tiempo
▶ Programación Inicial

ADJUST para seleccionar.
y ENTER.
MENU para salir de menús
```

```
◆ Programación Inicial
Sus selecciones son:
▶ Poner el reloj
Controles Especiales
Memorizar canales
Añadir/borrar canales

ADJUST para seleccionar.
y ENTER.
MENU para Menú Principal
```

```
◆ Programar grabaciones
▶ Canal 2
Día ---
Hora comienzo ---:--
Hora terminado ---:--
Vel. grabado AUTO

ADJUST para seleccionar.
y ENTER.
CANCEL para borrar.
```

- ① Si nunca se ha usado la videgrabadora, vaya al paso ③.
- ② Oprima el botón TIMER RESET en el panel trasero de la videgrabadora.
- ③ Oprima el botón POWER para encender la videgrabadora.
- ④ Oprima el botón MENU en el control remoto.
- ⑤ Verá el menú de seleccionar el idioma "Select Language." Utilice los botones de ajuste JOG/ADJUST en el control remoto para seleccionar el idioma.
- ⑥ Después de que haya seleccionado el idioma que desea, oprima el botón ENTER. Luego oprima el botón MENU para salir de los menús.

Cómo poner el reloj

- ① Oprima el botón MENU para ver el menú "Menú Principal."
- ② Utilice los botones de ajuste JOG/ADJUST para seleccionar el menú. "Programación Inicial." Luego oprima el botón ENTER.
- ③ Utilice los botones de ajuste JOG/ADJUST para seleccionar el menú "Poner el reloj." Luego oprima el botón ENTER.
- ④ Utilice los botones de ajuste JOG/ADJUST y el botón ENTER para ajustar el mes, año, día, hora y selección de hora de verano.
- ⑤ Al completar las selecciones de poner el reloj, oprima el botón ENTER. Luego oprima el botón MENU repetidamente para salir de los menús.

Cómo programar la videgrabadora par grabar

- ① Oprima el botón MENU para ver el menú "Menu Principal."
- ② Utilice los botones de ajuste JOG/ADJUST para seleccionar el menú "Programar grabaciones." Luego oprima el botón ENTER.
- ③ Utilice los botones de ajuste JOG/ADJUST y el botón ENTER para ajustar el canal, el día, la hora de comienzo, la hora de terminado, y la velocidad de la grabación.
- ④ Al completar las selecciones de programar grabaciones, oprima el botón ENTER. Luego oprima el botón MENU repetidamente para salir de los menús.

mitsubishi
VIDEO CASSETTE RECORDER
LIMITED WARRANTY

MITSUBISHI ELECTRONICS AMERICA, INC. ("MELA") warrants to the original purchaser of this video cassette recorder if purchased from an authorized MITSUBISHI Audio/Video Dealer that, should it prove defective by reason of improper workmanship and/or material:

- a. **Parts.** For one year from the date of original purchase at retail, we will repair or replace, at our option, any defective part including the video head without charge for the part. Parts used for replacement are warranted for the remainder of the original warranty period.
- b. **Labor.** For six months from the date of original purchase at retail, we will provide the labor for a warranty repair without charge at an authorized MITSUBISHI service center.
- c. **Notice.** To obtain warranty service, you must notify an authorized MITSUBISHI service center of any defect within the applicable warranty time period.

1. **TO OBTAIN WARRANTY SERVICE**, deliver your VCR to the nearest MITSUBISHI service center. Shipping expenses are your responsibility. The name and address of the nearest service center can be obtained from your MITSUBISHI Dealer, or by writing or calling MELA at the address and telephone number below. Proof of purchase date from an authorized MITSUBISHI Dealer is required when requesting warranty service. Present your sales receipt or other document which establishes proof and date of purchase. **THE RETURN OF THE OWNER REGISTRATION CARD IS NOT A CONDITION OF WARRANTY COVERAGE.** However, please detach and return the Owner Registration Card so that we can contact you should a question of safety arise which could affect you.

2. **THIS WARRANTY DOES NOT COVER** damage caused by: modification, alteration, repair or service of this product by anyone other than an authorized MITSUBISHI service center; physical abuse to, or misuse of, the VCR; operation in a manner contrary to the instructions which accompany the VCR; freight damage; or any damage caused by acts of God such as lightning or fluctuation in electrical power. This warranty also excludes all costs arising from installation, adjustment of user controls, external antenna systems, service of products purchased or serviced outside the U.S.A., initial technical adjustments (set-up) and user-required maintenance including head cleaning. Consult the operating instructions enclosed with the product for information regarding user controls.

3. **ANY EXPRESS WARRANTY NOT PROVIDED HEREIN, AND ANY REMEDY WHICH, BUT FOR THIS PROVISION, MIGHT ARISE BY IMPLICATION OR OPERATION OF LAW, IS HEREBY EXCLUDED AND DISCLAIMED. THE IMPLIED WARRANTIES OF MERCHANTABILITY AND OF FITNESS FOR ANY PARTICULAR PURPOSE ARE EXPRESSLY LIMITED TO A TERM OF ONE YEAR.**

4. **UNDER NO CIRCUMSTANCES SHALL MELA BE LIABLE TO PURCHASER OR ANY OTHER PERSON FOR ANY INCIDENTAL, SPECIAL OR CONSEQUENTIAL DAMAGES, WHETHER ARISING OUT OF BREACH OF WARRANTY, BREACH OF CONTRACT, OR OTHERWISE.**

5. Some state do not allow limitations on how long an implied warranty lasts, or the exclusion or limitation of incidental, special, or consequential damages, so the above limitations or exclusions may not apply to you.

6. This warranty gives you specific legal rights and you may also have other rights which vary from state to state.

7. **BEFORE REQUESTING SERVICE**, please review the instruction booklet to insure proper installation and correct customer control adjustment. If the problem persists, contact your nearest MITSUBISHI Dealer for name(s) of authorized MITSUBISHI Service Center(s). If you are unable to obtain the information, please call 1-800-332-2119, or write us at the address below.

MITSUBISHI ELECTRONICS AMERICA, INC.
P.O. Box 5025
Norcross, GA 30091-5025



RETAIN THIS PORTION FOR YOUR RECORDS

SERIAL NO. _____

CUSTOMER NAME _____

STREET ADDRESS _____

CITY _____ STATE _____ ZIP _____

PHONE () _____ PURCHASE DATE _____ / _____ / _____

MO DAY YR

PLACE OF PURCHASE _____



MITSUBISHI ELECTRONICS AMERICA, INC.
6100 Atlantic Boulevard
Norcross, GA 30071-1305

© 1995 Mitsubishi Electronics America, Inc.

872C131A3

PRINTED IN SINGAPORE