

SONY®

Trinitron® Color TV

Operating Instructions

KV-32XBR48
KV-34XBR48C
KV-35XBR48
KV-35XBR88
KV-37XBR48M

© 1997 by Sony Corporation

Welcome!

Thank you for purchasing the Sony Trinitron® Color TV. This manual is for models KV-32XBR48, 34XBR48C, 35XBR48, 35XBR88 and 37XBR48M.

Model KV-35XBR48 is used for illustration purposes. Differences in operation are indicated in the text; for example, "KV-35XBR48 only".

The features you will enjoy include:

- Two ON/OFF TIMERS
- Picture-in-Picture (PIP) and Picture & Picture (P&P) (Twin View™)
- FAVORITE CHANNEL feature, allowing you to view and choose from eight of your favorite programs
- CHANNEL INDEX feature, allowing you to view and choose from twelve programs
- Customized on-screen menus
- One Y/B-Y/R-Y input for DVD Player connection
- Three AUDIO/VIDEO inputs
- Two S Video inputs

Precautions

Safety

- Operate the TV only on 120 V AC (except KV-34XBR48C)
- Operate the TV on 220 V AC (KV-34XBR48C only)
- The plug is designed, for safety purposes, to fit into the wall outlet only one way. If you are unable to insert the plug fully into the outlet, contact your dealer. (except KV-34XBR48C)
- If any liquid or solid object should fall inside the cabinet, unplug the TV immediately and have it checked by qualified service personnel before operating it further.
- If you will not be using the TV for several days, disconnect the power by pulling the plug itself. Never pull on the cord.

For details concerning safety precautions, see the supplied leaflet "IMPORTANT SAFEGUARDS".

Installing

- To prevent internal heat buildup, do not block the ventilation openings.
- Do not install the TV in a hot or humid place, or in a place subject to excessive dust or mechanical vibration.
- The AC power cord is attached to the rear of the TV with hooks. Do not attempt to remove the cord from these hooks. Doing so could cause damage to the TV. (see "Note on AC Power Cord" on page 2)

Using This Manual

This manual is divided into four major sections. We recommend that you carefully review the contents of each section in the order provided to ensure that you fully understand the operation of your new TV.

1 Installing and Connecting the TV.

This section will guide you through your initial set up. It will show you how to connect your new components, connect to your antenna or cable, and connect any accessories.

2 Basic Set Up.

This section will teach you the basic skills needed to operate your new TV. It will show you how to operate special functions of the remote control.

3 Using your New TV.

This section will show you how to begin using your new TV. It will show you how to use the AUTO SET UP feature, and how to use your remote control's features.

4 Adjusting your Set Up (menus).

This section will teach you how to access on-screen menus and adjust your TV's settings.

Instructions in this manual are written for the remote control. Similar controls may be found on the TV console.

in a resident
generates, us
energy and, if
with the instr
with radio c
guarantee tha
ar installation
ul interferenc
which can be c
off and on, th
interference b
easures:
or relocate th
he separation

he equipment
from that to v
l.
ie dealer or a
for help.

tioned that a
ns not expres
ild void your

it is for the re
-32XBR48, 34
35XBR88, 37

Connecting and Installing the TV

Note on AC Power Cord

The AC power cord is attached to the rear of the TV with hooks. Do not attempt to remove the cord from these hooks. Doing so could cause damage to the TV.

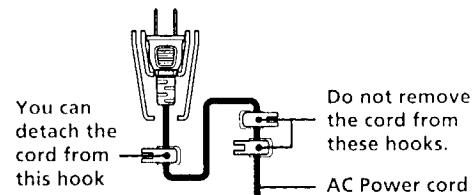

Connector Types

You may find it necessary to use some of the following connector types during set up.

Coaxial cable

Standard TV cable and antenna connector

Plug Type



Screw-on Type



S Video cable

High quality video connector for enhanced picture quality

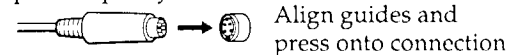

Audio/Video cable

Conventional Audio/Video cable



Audio (Left) - White

Audio (Right) - Red

Video - Yellow

(Some DVD Players are equipped with the following three video connectors.)

Y - Green

B-Y (Cb) - Blue

R-Y (Cr) - Red

S-Link/CONTROL S cable

Sony connector for S-Link and CONTROL S connections. These features are exclusive to Sony products, and allow greater control of all Sony equipment.



Note:

- For S-Link and CONTROL S connections, you can use the combined S-Link/CONTROL S cable provided with some Sony video equipment, or you can purchase a separate S-Link/CONTROL S cable (RK-G69HG).

Making Connections

For the best picture quality, a cable TV system or outdoor antenna is recommended.

Connecting directly to cable or an antenna

The connection you choose will depend on the cable found in your home. Newer homes will be equipped with standard coaxial cable (see **A**); older homes will probably have 300-ohm twin lead cable (see **B**); still other homes may contain both (see **C**).

- A** • VHF only
or
• VHF/UHF
or
• Cable
- 75-ohm coaxial cable (Rear of TV) VHF/UHF
-

- B** • VHF only
or
• UHF only
or
• VHF/UHF
- 300-ohm twin lead cable (Rear of TV) VHF/UHF
-
- Antenna connector

- C** • VHF
- 75-ohm coaxial cable (Rear of TV) VHF/UHF
- and
- UHF
- 300-ohm twin lead cable
-
- EAC-66 U/V mixer (not supplied)

Cable or antenna

Most simple connection. Connection is made directly from the cable or antenna to the TV.

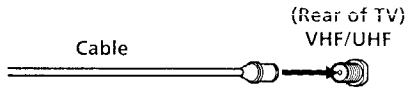

Cable and antenna

You may find it convenient to use the following set up if your cable provider does not feature local channels that you are able to receive using an antenna.

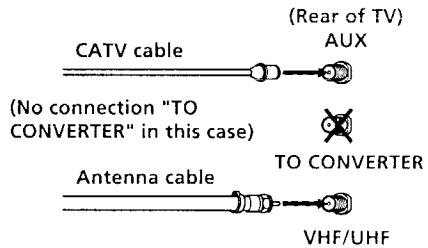

Select Cable or ANT mode by pressing ANT on the remote control.

Connecting a cable box

Some pay cable TV systems use scrambled or encoded signals that require a cable box* to view all channels.

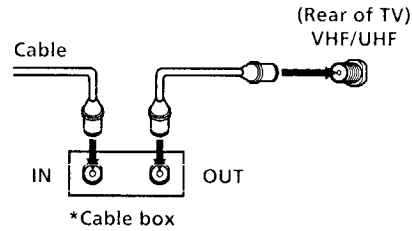

Note:

- If you will be controlling all channel selection through your cable box, you should consider using the CHANNEL FIX feature. (see "CHANNEL SET UP" on page 26)

Cable box and cable

Some pay cable TV systems use scrambled or encoded signals requiring a cable box* only for certain channels (e.g. HBO, SHOWTIME, etc.).

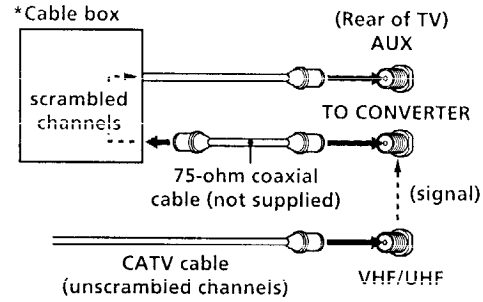

For this set up, you can switch between scrambled channels (through your cable box), and normal (CATV) channels by pressing ANT on your remote control.

Notes:

- You may be able to program your Sony remote control to operate your cable box. (see "Operating a Cable Box or DBS Receiver" on page 34)
- During PIP, P&P, CHANNEL INDEX or FAVORITE CHANNEL viewing, the AUX input can only be viewed in the main picture.
- If you are connecting a cable box through the AUX input and would like to switch between the AUX and normal (CATV) input you should consider using CHANNEL FIX. (see "CHANNEL SET UP" on page 26)

Connecting and Installing the TV (continued)

Connecting an antenna/cable TV system with a VCR

- 1 Attach the coaxial connector from your cable or antenna to IN on your VCR.
- 2 Using AUDIO/VIDEO connectors, connect AUDIO and VIDEO OUT on your VCR to AUDIO and VIDEO IN on your TV (Yellow-VIDEO, White-AUDIO Left, Red-AUDIO Right).
- 3 Using a coaxial connector, connect OUT on your VCR to VHF/UHF on your TV.

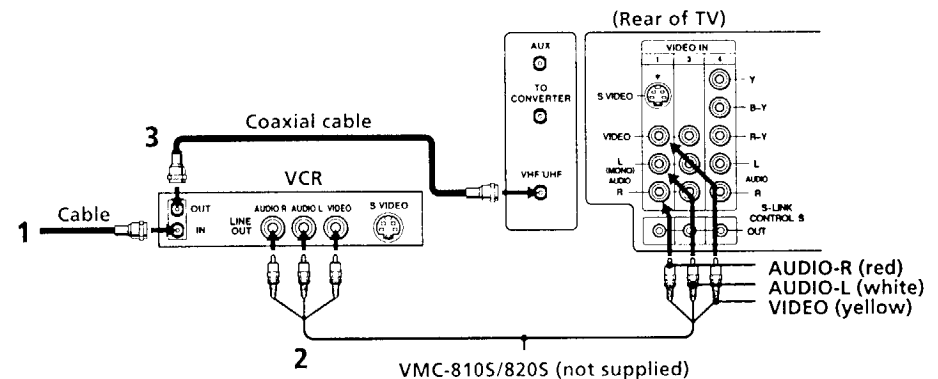

Connecting to an S Video equipped VCR

- 1 Attach the coaxial connector from your cable or antenna to IN on your VCR.
- 2 Using AUDIO connectors, connect AUDIO OUT on your VCR to AUDIO IN on your TV (White-AUDIO Left, Red-AUDIO Right).
- 3 Using a coaxial connector, connect OUT on your VCR to VHF/UHF on your TV.
- 4 Using an S VIDEO connector, connect S VIDEO on your VCR to S VIDEO on your TV.

Note:

- If you are connecting a monaural VCR, connect only the single audio output to the left (MONO) input on your TV.

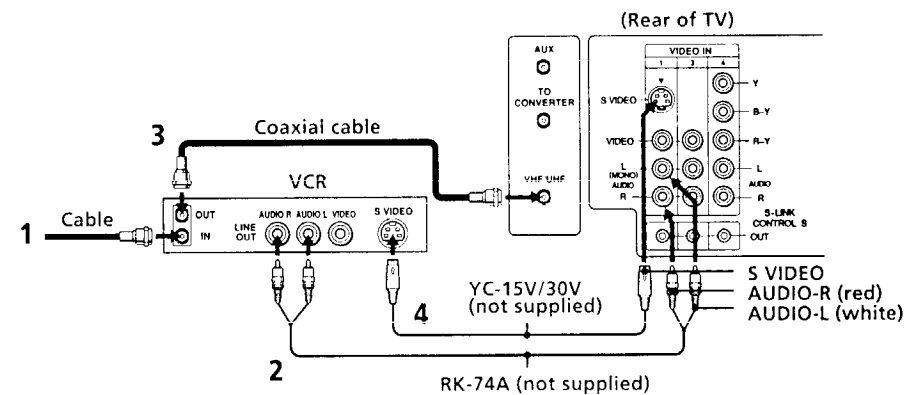

Connecting a VCR and TV with a cable box

- 1 Connect the single (input) jack of the Splitter to your incoming cable connection, and connect the other two (output) jacks (using coaxial cable) to IN on your cable box and VHF/UHF on your TV.
- 2 Using a coaxial connector, connect OUT on your cable box to IN on your VCR.
- 3 Using AUDIO/VIDEO connectors, connect AUDIO and VIDEO OUT on your VCR to AUDIO and VIDEO IN on your TV (Yellow-VIDEO, White-AUDIO Left, Red-AUDIO Right).

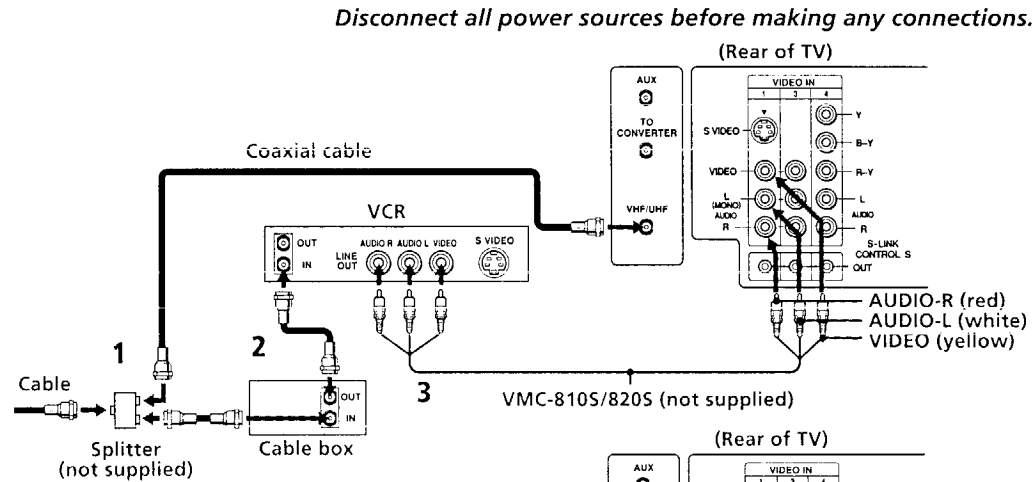

Connecting to an S Video equipped VCR with a cable box

- 1-2 Perform as described above.
- 3 Using AUDIO connectors, connect AUDIO OUT on your VCR to AUDIO IN on your TV (White-AUDIO Left, Red-AUDIO Right).
- 4 Using an S VIDEO connector, connect S VIDEO on your VCR to S VIDEO on your TV.

Note:

- To view scrambled channels through your cable box, select the video input which your cable box is connected to by pressing TV/VIDEO.

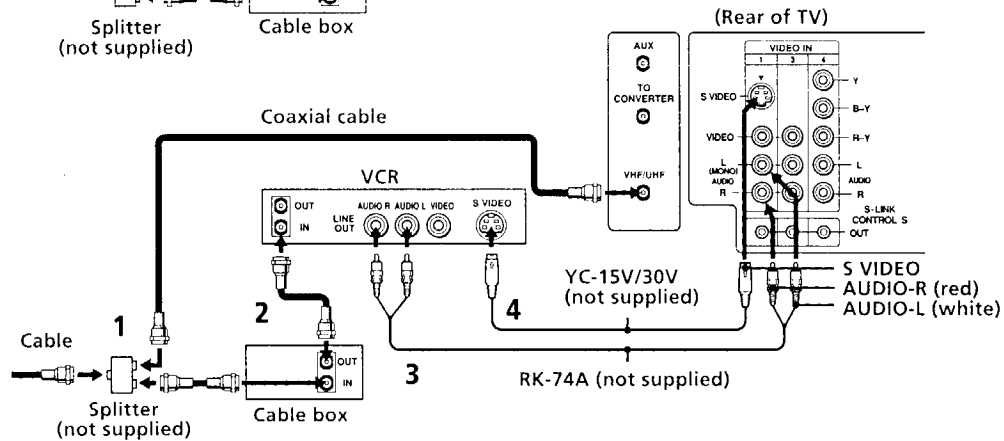

Connecting and Installing the TV (continued)

Connecting a DBS (Direct Broadcast Satellite) receiver

- 1 Connect the cable from your satellite antenna to your DBS receiver.
- 2 Attach the coaxial connector from your cable or antenna to VHF/UHF on your TV.
- 3 Using AUDIO/VIDEO connectors, connect AUDIO and VIDEO OUT on your DBS receiver to AUDIO and VIDEO IN on your TV.

Connecting a DBS (Direct Broadcast Satellite) receiver and a VCR

- 1 Connect the cable from your satellite antenna to your DBS receiver.
- 2 Attach the coaxial connector from your cable or antenna to VHF/UHF IN on your VCR.
- 3 Using a coaxial connector, connect VHF/UHF OUT on your VCR to VHF/UHF on your TV.
- 4 Using AUDIO/VIDEO connectors, connect AUDIO and VIDEO OUT on your DBS receiver to AUDIO and VIDEO IN on your VCR.
- 5 Using AUDIO/VIDEO connectors, connect AUDIO and VIDEO OUT on your VCR to AUDIO and VIDEO IN on your TV.

Note:

- To view input from the DBS or VCR, select the video input which your DBS receiver or VCR is connected to by pressing TV/VIDEO on the remote control.

Disconnect all power sources before making any connections.

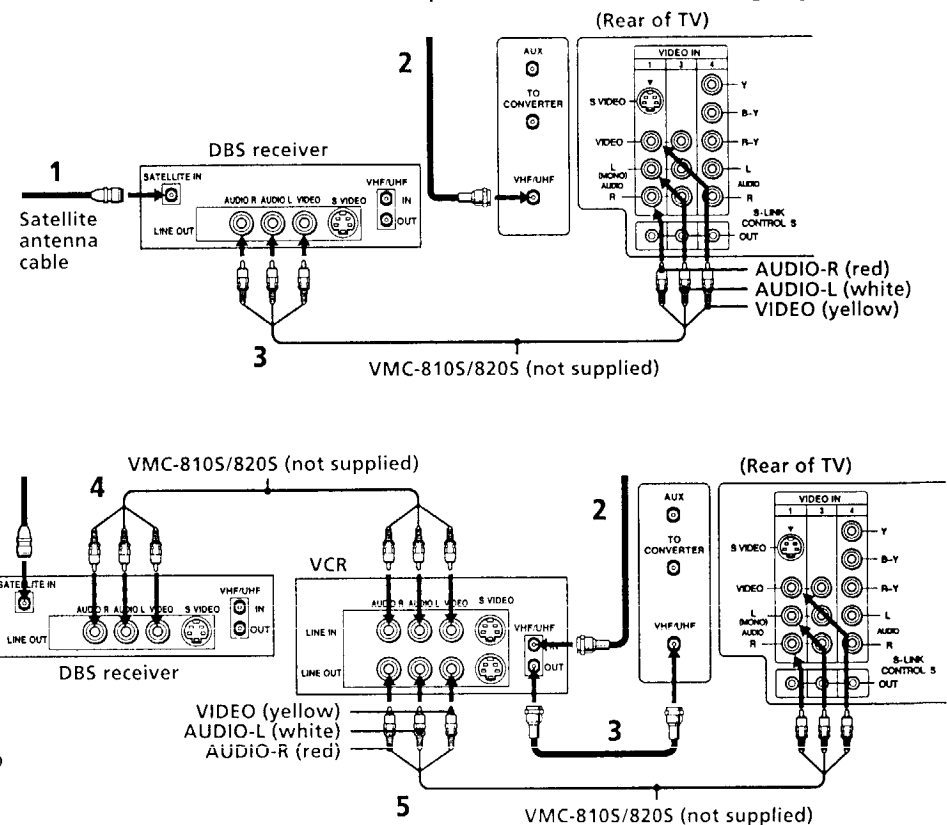

Connecting an audio system

For more dynamic sound, connect your audio system to your TV.

- 1 Using AUDIO connectors, connect AUDIO OUT on your TV to one of the unused Line inputs (e.g. Tape-2, AUX1, etc.) on your stereo (White-AUDIO Left, Red-AUDIO Right).
- 2 Set your stereo to the chosen Line input and use the AUDIO menu to set your audio output. (see "SPEAKER" and "AUDIO OUT" on page 24)

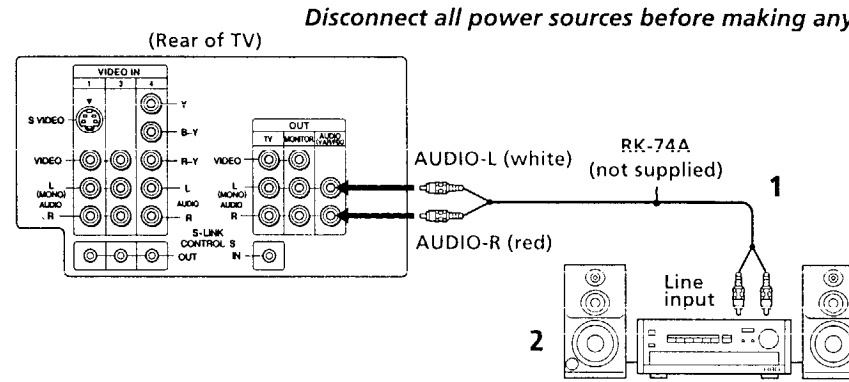

Connecting an AV receiver

For greater control of all audio and video equipment, connect your AV receiver.

- 1 Using AUDIO/VIDEO connectors, connect VIDEO 1 IN on your TV to Monitor AUDIO and VIDEO OUT on your AV receiver.
- 2 Using AUDIO/VIDEO connectors, connect TV OUT on your TV to TV AUDIO and VIDEO IN on your AV receiver.

Note:

- You may want to use CHANNEL FIX to fix your TV's input to the AV receiver (VIDEO 1). (see "CHANNEL SET UP" on page 26)

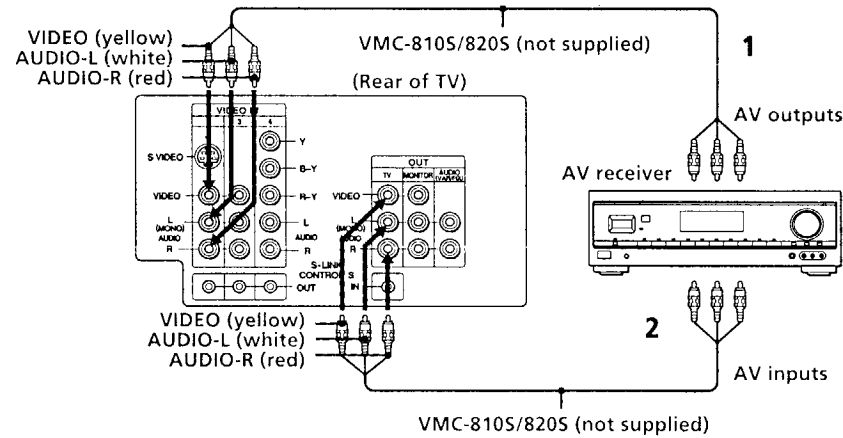

Connecting and Installing the TV (continued)

Disconnect all power sources before making any connections.

Connecting two VCRs for tape editing using MONITOR OUT

MONITOR OUT gives you the ability to use a second VCR to record a program being played by the primary VCR or to perform tape editing and dubbing.

- 1 Connect the VCR intended for playback using the connection instructions on page 4 of this manual.
- 2 Using AUDIO/VIDEO connectors, connect AUDIO and VIDEO IN on your VCR intended for recording to MONITOR AUDIO and VIDEO OUT on your TV.

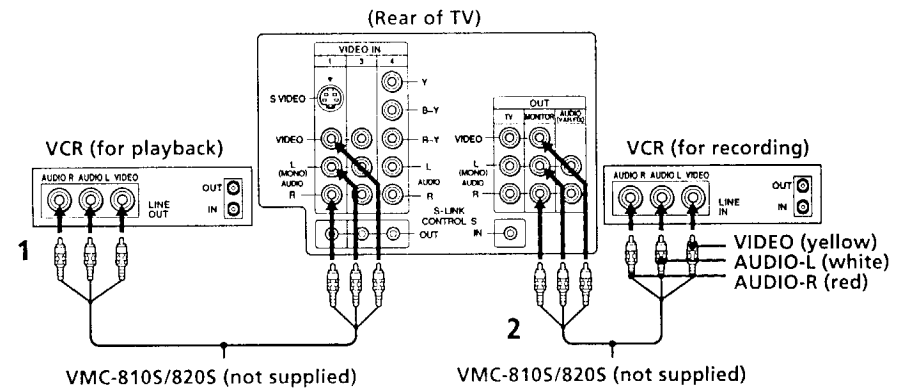

Notes:

- Do not change the input signal while editing through MONITOR OUT.
- When connecting a single VCR to the TV; if VCR LINE OUT is connected to TV VIDEO IN, **do not** connect the TV MONITOR OUT jacks to the VCR LINE INPUT (see right). Doing so will cause program interference and other viewing problems.

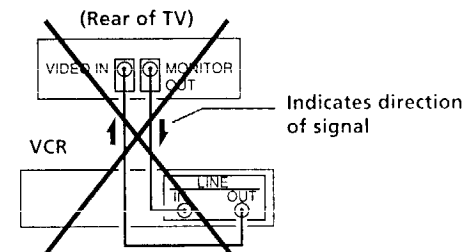

Disconnect all power sources before making any connections.

Connecting a DVD Player (Upper illustration)

Using AUDIO/VIDEO connectors, connect VIDEO 1 IN on your TV to LINE OUT on your DVD Player.

Connecting a DVD Player with component video output connectors (Lower illustration)

- 1 Using AUDIO connectors, connect AUDIO R and L of the LINE OUT on your DVD Player to AUDIO R and L on the VIDEO IN 4 panel at the rear of your TV.
- 2 Using three VIDEO connectors, connect Y, B-Y, and R-Y on the COMPONENT VIDEO OUT on your DVD Player to Y, B-Y, and R-Y on the VIDEO IN 4 panel at the rear of your TV.

Notes:

- Some DVD Player terminals may be labeled Y, Cb, and Cr. If so, connect Y (green) to Y, B-Y (blue) to Cb, and R-Y (red) to Cr.
- Because the high quality pictures on a DVD disc contain a lot of information, picture noise may appear. In this case, adjust the SHARPNESS in the VIDEO menu. (see SHARPNESS on page 23)

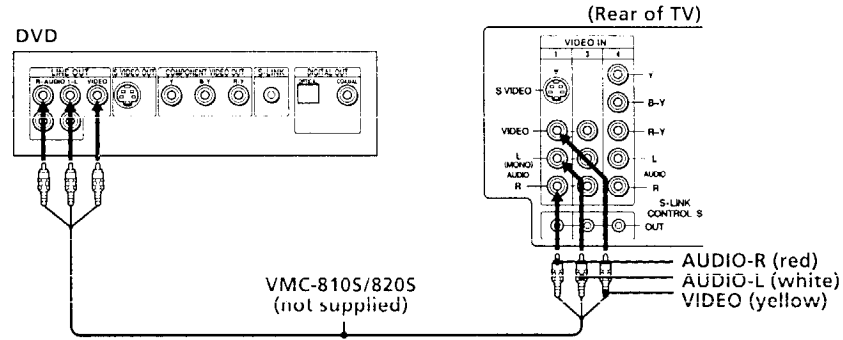

Connect your DVD Player directly to your TV. Connecting the DVD Player through other video equipment will cause unwanted picture noise.

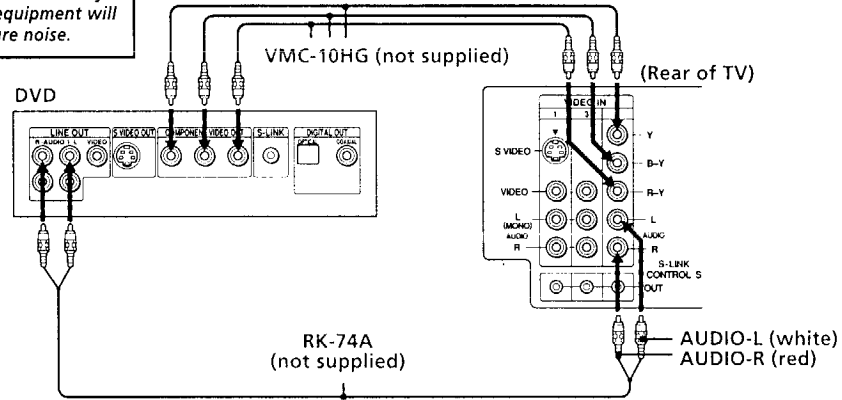

Connecting and Installing the TV (continued)

Connecting a camcorder

Use this connection to view a picture directly from your camcorder.

Using AUDIO/VIDEO connectors, connect AUDIO and VIDEO OUT on your camcorder to AUDIO and VIDEO IN on the front panel of your TV (Yellow-VIDEO, White-AUDIO Left, Red-AUDIO Right).

Notes:

- If you are connecting a monaural camcorder, connect only the single audio output to the left (MONO) input on your TV.
- If you have an S Video equipped camcorder, you can use an S Video connection.

Disconnect all power sources before making any connections.

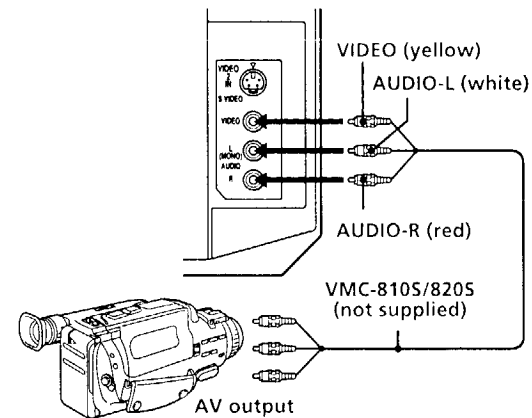

Disconnect all power sources before making any connections.

Using the S-Link function

S-Link is a Sony innovation designed to make your Sony components work together. It allows you to automatically switch the TV input mode to video when you press PLAY on your Sony S-Link VCR. It also allows you to turn the VCR and TV off at the same time with the SYSTEM OFF button.

- 1 Connect your VCR. (see "Connecting an antenna/cable TV system with a VCR" or "Connecting to an S Video equipped VCR" on page 4)
- 2 Using an S-LINK connector, connect the S-LINK jacks on your VCR and TV. Ensure that both ends are seated firmly and that the TV S-LINK connector is in the same row as the AUDIO/VIDEO connectors.

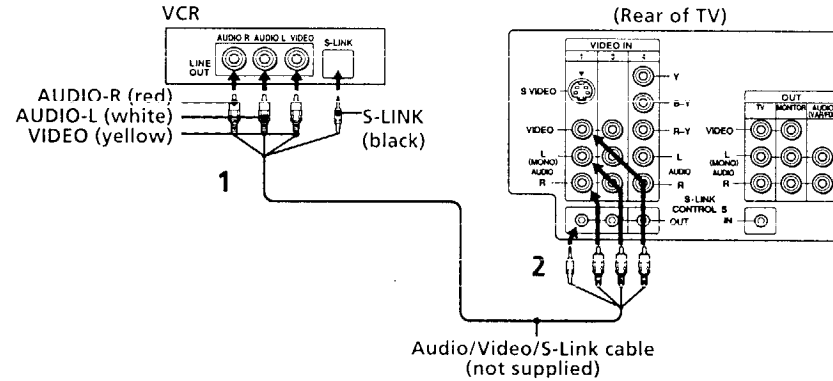

Connecting and Installing the TV (continued)

Using the CONTROL S feature

CONTROL S allows you to control your TV and other Sony equipment with one remote control.

To control other Sony equipment with your TV's remote control, connect the CONTROL S IN jack of the equipment to the CONTROL S OUT jack on the TV with the CONTROL S cable.

To control your TV with other Sony equipment's remote control, connect the CONTROL S OUT jack of the equipment to the CONTROL S IN jack on the TV with the CONTROL S cable.

Disconnect all power sources before making any connections.

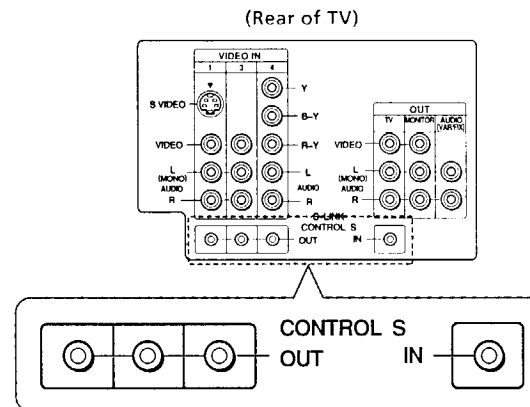

Using the Console Box (KV-35XBR88 only)

The console box features electronic sliding doors and three AC outlets.

The AUTO ACCESS switch on the front of the console controls operation of the sliding doors.

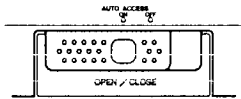

AC outlets

Your TV cord has been designed to connect to one of the AC outlets on the rear of the console. You will have two additional outlets to connect accessory equipment to.

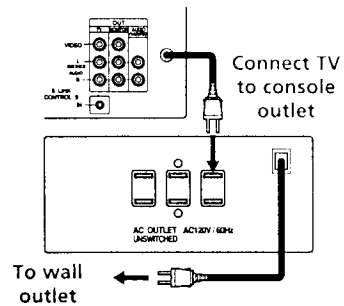

CAUTION

- Do not connect the console AC power cord to a wall outlet until you have completed making all connections.
- Do not connect equipment with a combined wattage of more than 300 W/3 A to the console outlet (the wattage of this TV set is 198 W).

Operating your console box automatically (AUTO ACCESS ON)

When the AUTO ACCESS switch is set to ON, the doors will operate automatically. Whenever the sensor detects movement within its range, the doors will open and remain open until the range is clear.

Refer to the following diagram to determine the range of the automatic feature.

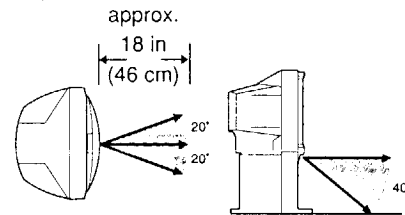

Notes:

- People with small children and pets should consider using the manual feature to avoid possible injury and/or damage.

- The ultrasonic sensor may detect movement, drafts, vibrations, sound waves, or electronic signals that will cause the doors to open inadvertently.
- If the travel of the doors is interrupted, they will reopen automatically and remain opened. When you want to close the doors again, press the OPEN/CLOSE button (or set the AUTO ACCESS switch to OFF).

Operating your console box manually (AUTO ACCESS OFF)

When the AUTO ACCESS switch is set to OFF, the doors will operate manually. Pressing on the OPEN/CLOSE button will cause the doors to open or close and remain in that position until the switch is pressed again.

Basic Set up

Inserting Batteries

Insert two size AA (R6) batteries (supplied) by matching the + and – on the batteries to the diagram inside the battery compartment.

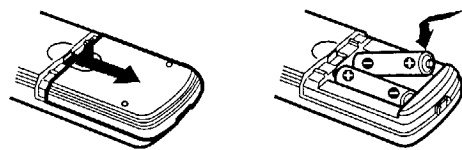

Notes:

- Remove the batteries to avoid damage from possible battery leakage whenever you anticipate that the remote control will not be used for an extended period.
- Handle the remote control with care. Avoid dropping it, getting it wet, or placing it in direct sunlight, near a heater, or where the humidity is high.
- Your remote control can be programmed to operate most video equipment. (see "Operating Video Equipment" on page 32)

Using the Remote Control Joystick

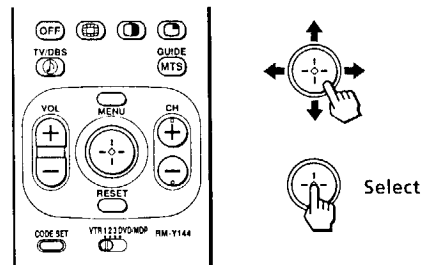

The supplied remote control has a joystick which allows for movement of the on-screen selector in four directions. Pressing up, down, left, or right on the joystick will cause the selector to *move* in the selected direction. Pressing down on the center of the joystick (⊕) will *activate* the selected item.

Adjusting Sliders

When menu items present a slider (▬▬▬▬▬▬ or ▬▬▬▬▬▬), press up, down, left, or right on the joystick to adjust the setting.

On Line Help/Instructions

Several menu windows will provide prompts and instructions to assist you in navigating through the different functions.

When the instructions are presented, use them to supplement the instructions in this manual.

Setting Up the TV Automatically

The EASY SETUP GUIDE feature will allow you to set the on-screen language and set all receivable channels. The EASY SETUP GUIDE screen will appear every time you turn on the TV until you perform AUTO PROGRAM.

The EASY SETUP GUIDE feature does not apply for installations that use a cable box for all channel selection.

You can also set up the TV manually. (see "Using the SET UP menu" on page 26)

Tips

- Perform this function during the day, with the antenna and/or cable properly connected, to ensure that all available channels will be broadcasting and receivable.
- After using EASY SETUP GUIDE you will still have the option of adjusting any of the system settings, like erasing channels, through the SET UP menu. (see "CHANNEL SET UP" on page 26)

Using the buttons on the top of the TV:

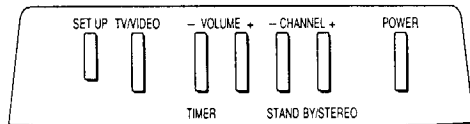

- 1 Press POWER to turn on the TV. The EASY SETUP GUIDE screen appears.

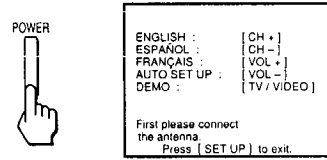

- 2 Press CHANNEL + to select ENGLISH, CHANNEL - to select ESPAÑOL or VOLUME + to select FRANÇAIS.

The screen will change to reflect your choice.

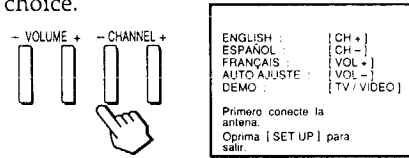

For a DEMO of functions and menus, press TV/VIDEO.

- 3 Press VOLUME - to continue.

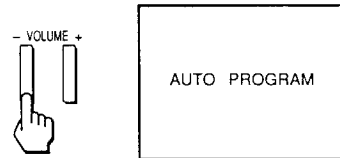

"AUTO PROGRAM" appears and the TV starts scanning and presetting channels automatically. When all the receivable channels are stored, the lowest numbered channel is displayed. If the TV receives cable TV channels, CABLE is set to ON automatically.

To perform AUTO SET UP again

- Press SET UP on top of the TV.
- Press CHANNEL +, CHANNEL - or VOLUME + to select a language.
- Press VOLUME - to restore factory settings ("CONTINUE TO AUTO PROGRAM?" will appear on the screen.) Press CHANNEL+ to execute or CHANNEL- to exit.
- Press SET UP to exit.

Notes:

- Before you perform AUTO SET UP again, make sure that the input from ANT (not AUX) is selected by pressing ANT until "AUX" does not appear next to the channel number.
- When you perform AUTO PROGRAM, your CHANNEL FIX, TIMER, and CHANNEL BLOCK settings will be erased.

Using the White Labeled Buttons for TV Operations

SLEEP	Press repeatedly until the TV displays the approximate time in minutes (30, 60, or 90) that you want the TV to remain on before shutting off automatically. Cancel by pressing until "SLEEP OFF" appears.
DISPLAY	Press repeatedly to step through available displays: Status Channel number, current time, channel caption (if set), and MTS mode (if SAP is selected) are displayed. SAP indication disappears after three seconds. XDS XDS (Extended Data Service) shows a network name, program name, program type, program length, program description, call letters, and time of the show if the broadcaster offers this service. Caption Vision Caption Vision will be displayed on the screen if the broadcaster offers this service. (see right) To cancel the display, press DISPLAY repeatedly until "DISPLAY OFF" appears. "DISPLAY OFF" disappears after three seconds.
TV/VIDEO	Press repeatedly to step through available video inputs: TV, VIDEO 1, VIDEO 2, VIDEO 3 and VIDEO 4 If you select SKIP as a VIDEO LABEL in the SET UP menu, your TV will skip the video input you selected. (see "VIDEO LABEL" on page 27)
ANT (AUX input)	Press to change between the VHF/UHF input and the AUX input. (For detailed connection information, see "Cable box and cable" or "Cable and antenna" on page 3)
MTS	Press to cycle through the Multi-channel TV Sound (MTS) options. (see "MTS" on page 24)
SYSTEM OFF (green labeled button)	Press to turn off the TV and all other equipment connected with S-Link. (see "Using the S-Link function" on page 11)

CAPTION VISION

(Closed Caption)

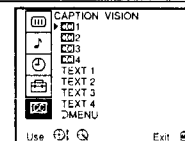

Some programs are broadcast with Caption Vision. To display Caption Vision, select CC1, CC2, CC3, CC4, TEXT1, TEXT2, TEXT3, or TEXT4 from the menu, then press DISPLAY until Caption Vision is displayed.

CC1, CC2, CC3, or CC4 shows you a caption, that is, a printed version of the dialogue or sound effects of a program. (The mode should be set to CC1 for most programs) TEXT1, TEXT2, TEXT3, or TEXT4 shows you text, that is, information presented, using half of the screen. It is not usually related to the program.

Notes:

- Poor reception of TV programs can cause errors in Caption Vision and XDS. Captions may appear with a white box or other errors instead of intended text.
- XDS, Caption Vision, and the status display cannot be used at the same time.

Using your New TV (continued)

Watching Two Programs at One Time — PIP/P&P (Twin View™)



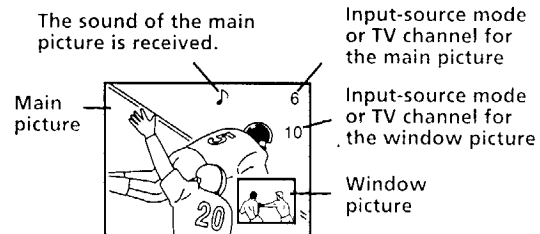

The Picture-in-Picture (PIP) feature allows you to view two channels simultaneously, one in the full size "main" picture and one in a smaller "window" picture.

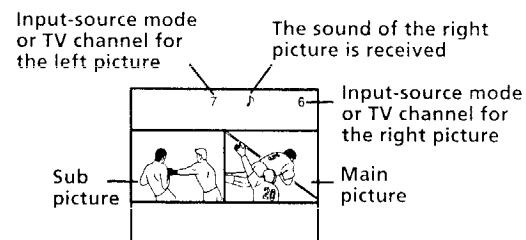

The Picture-and-Picture (P&P) feature allows you to view two channels simultaneously, both in a reduced size screen. The main picture will appear on the right.



REFER TO THE ILLUSTRATION OF THE REMOTE CONTROL ON THE INSIDE FRONT COVER OF THIS MANUAL AS YOU REVIEW THIS CHART

Using the Yellow Labeled Buttons for PIP Operations. Some control buttons for PIP and P&P are located under the cover on the top of the remote control.	
	Press to display a window picture (PIP). Each time you press, the picture size will change (1/4 → 1/9 → 1/16). Press OFF to remove the window picture. ←
	Press to display right (main) and left pictures (P&P). Press OFF to cancel.
TV/VIDEO 	Press repeatedly to step through available video inputs: TV, VIDEO 1, VIDEO 2, VIDEO 3 and VIDEO 4 PIP will display the video source in the window picture. P&P will display the video source in the left picture.
AUDIO 	Press to alternate sound between the main picture and the window picture for PIP and the right and left picture for P&P. The symbol "♪" will appear for a few seconds to indicate which picture's sound is being received.

Using your New TV (continued)

Using CHANNEL INDEX

You can use the CHANNEL INDEX feature to display multiple channels for direct selection.

Channels used for CHANNEL INDEX will come directly from the TV's list of receivable channels (those set during AUTO PROGRAM or through the SET UP menu).

- 1 Press  once to display the current channel in the center of the screen surrounded by the first twelve receivable channels.



A yellow frame will appear to indicate current channel selection.

- 2 When you find a channel that you wish to view, use the joystick to move the yellow frame to that picture and press .

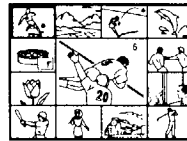

The selected channel will be retrieved and displayed for normal viewing.



Notes

- You cannot move the yellow frame until all of the surrounding pictures appear.
- The TV will continually update each of the surrounding pictures while the CHANNEL INDEX screen is displayed.
- Sound will only be heard from the center picture while the CHANNEL INDEX screen is displayed.













- If one of the pictures received through CHANNEL INDEX is snowy, the entire screen may appear snowy. In this case, erase the snowy channel using CHANNEL ERASE/ADD. (see "CHANNEL SET UP" on page 26)

Using the Yellow Labeled Buttons for CHANNEL INDEX Operations.

Some control buttons are located under the cover on the top of the remote control.



REFER TO THE ILLUSTRATION OF THE REMOTE CONTROL ON THE INSIDE FRONT COVER OF THIS MANUAL AS YOU REVIEW THIS CHART

	<p>Press to access CHANNEL INDEX. Press again to access the next twelve receivable channels.</p>
<p>CH +  CH - </p>	<p>Press to cycle through the receivable channels one at a time.</p>
	<p>Press to cancel the current operation and return to normal TV viewing.</p>
<p>FREEZE </p>	<p>Press to freeze the center picture. Press again to cancel the frozen picture and resume normal center picture viewing.</p>
<p>Using the White Labeled Buttons for Center Picture Operations.</p>	
<p>TV/VIDEO </p>	<p>Press to cycle the center picture through the video inputs. The surrounding channels will not change.</p>
<p>ANT </p>	<p>Press to replace the center picture with a channel received through the AUX input. Press again to return to CATV input.</p>
<p>CH  </p> <p>or  -  or JUMP and ENTER </p>	<p>Press to select the channel for the center picture. (see "Watching the TV" on pages 16-17)</p>

Adjusting your SET UP (menus)

Learning Menu Selection

Use the MENU button to access a menu and use the joystick to alter settings. Use the following example to learn how to modify settings.

- 1 Press the MENU button.
The main menu appears.

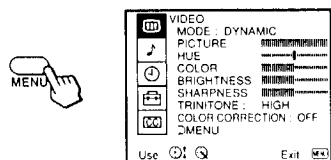

- 2 Press up or down on the joystick to highlight the desired menu and press \odot to activate it.

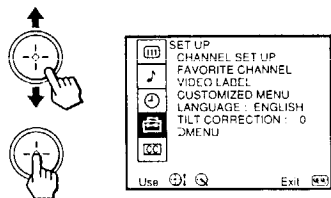

- 3 Press up or down on the joystick until the cursor points to the desired option.

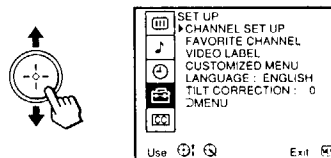

- 4 Press \odot .
Options for your selection will be displayed.

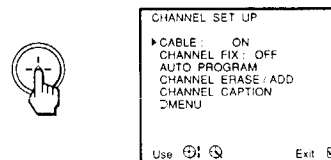

- 5 Press up or down on the joystick to make your selection and and press \odot to activate it.

The previous screen will reappear.

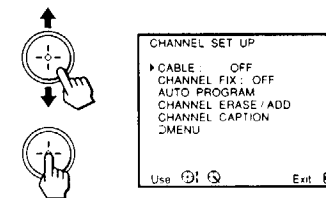

When you are done with changes to the selected menu, choose MENU to return to the main menu. Once you have completed all menu corrections, press MENU on the remote control to exit the menu screens.

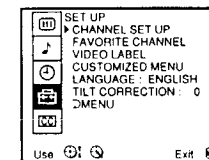

Note:

- Pressing MENU on the remote control will allow you to exit from the menus at any time.

III Using the VIDEO Menu

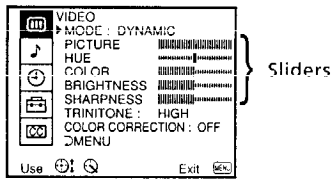

For detailed information on using the remote control to modify menu settings, refer to "Learning Menu Selection" on page 22.

To select the VIDEO III menu:

Display → Highlight III → Select

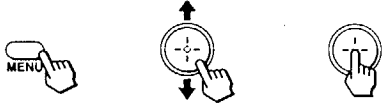

To restore the factory settings

Press RESET on the remote control while the VIDEO menu is selected.

MODE <i>Customized picture viewing</i>	DYNAMIC: Select for enhanced picture contrast and sharpness. STANDARD: Select to display a standard picture. MOVIE: Select to display a finely detailed picture. SPORTS: Select to display a vivid, bright picture. You can alter the VIDEO menu settings (e.g., PICTURE, HUE) for each MODE. Select each mode individually and then press RESET to restore factory settings.
PICTURE <i>Picture Adjustment</i>	Adjust slider right (up) to increase picture contrast and create more vivid color. Adjust slider left (down) to decrease picture contrast and soften the color.
HUE <i>Picture Adjustment</i>	Adjust slider right (up) to increase the green tones. Adjust slider left (down) to decrease the green tones.
COLOR <i>Picture Adjustment</i>	Adjust slider right (up) to increase color intensity. Adjust slider left (down) to decrease color intensity.
BRIGHTNESS <i>Picture Adjustment</i>	Adjust slider right (up) to brighten the picture. Adjust slider left (down) to darken the picture.
SHARPNESS <i>Picture Adjustment</i>	Adjust slider right (up) to sharpen the picture. Adjust slider left (down) to soften the picture.
TRINITONE <i>White Intensity Adjustment</i>	HIGH: Select to give the white colors a blue tint. MEDIUM: Select to give the white colors a white tint. NTSC STD: Select to give the white colors a red tint.
COLOR CORRECTION <i>Color Ratio Adjustment</i>	Select ON to emphasize reds and blues. Select OFF to emphasize greens.

Adjusting your SET UP (menus) (continued)

Using the AUDIO Menu

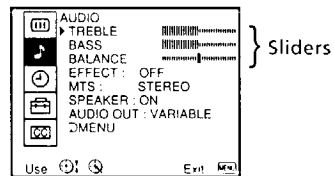

For detailed information on using the remote control to modify menu settings, refer to “Learning Menu Selection” on page 22.

To select the AUDIO menu:

Display → Highlight → Select

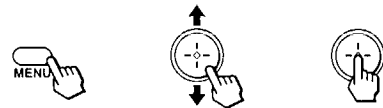

To restore the factory settings

Press RESET on the remote control while the AUDIO menu is selected.

Tip

Press for direct selection of an EFFECT setting.

TREBLE <i>Sound Adjustment</i>	Adjust slider right (up) to increase high pitched sounds. Adjust slider left (down) to decrease high pitched sounds.
BASS <i>Sound Adjustment</i>	Adjust slider right (up) to increase low pitched sounds. Adjust slider left (down) to decrease low pitched sounds.
BALANCE <i>Sound Adjustment</i>	Adjust slider right (up) to emphasize right speaker volume. Adjust slider left (down) to emphasize left speaker volume.
EFFECT <i>Customize sound effect based on the program's audio type.</i>	AUTO SRS: Automatically detects signal type and switches the TV effect between SRS and SIMULATED. SRS: Produces a dynamic three dimensional sound for stereo signals. SIMULATED: Adds a surround-like effect to mono programs. OFF: Normal stereo or mono reception.
MTS <i>Enjoy stereo. bilingual and mono programs.</i>	STEREO: Select for stereo reception when viewing a program broadcast in stereo. SAP: Select to listen to a bilingual broadcast. (non-SAP programs will be muted when this feature is selected) MONO: Select for mono reception. (use to reduce noise during stereo broadcasts) Quick MTS access: Press MTS on your remote control to cycle through the MTS options as follows: (STEREO → SAP → MONO → STEREO)
SPEAKER <i>Custom selection of audio output source.</i>	ON: Select to listen to the sound from the TV speakers alone or the TV speakers and a separate stereo system. OFF: Select to turn off the TV speakers and listen to the TV's sound only through external audio system speakers.
AUDIO OUT <i>Easy control of volume adjustments.</i>	AUDIO OUT can only be set when speakers are set to OFF. VARIABLE: Sound output varies according to the TV settings. VOLUME, BASS, TREBLE, and BALANCE are adjusted through the TV. Useful when you want to use your remote control to control the output of a separate audio system. FIXED: Sound output is held at a fixed level. VOLUME, BASS, TREBLE, and BALANCE are fixed to the factory settings. VOLUME adjustments are made through your stereo.

⌚ Using the TIMER Menu

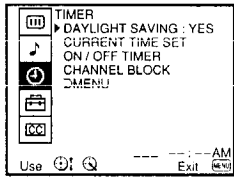

After setting the clock you can use the timer to turn the TV on and off.

For detailed information on using the remote control to modify menu settings, refer to "Learning Menu Selection" on page 22.

To select the TIMER ⌚ menu:

Display → Highlight ⌚ → Select

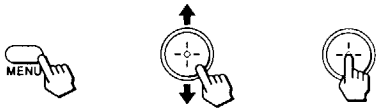

Tip 💡

Set daylight saving time before setting the clock. Any loss of power will cause these settings to be erased.

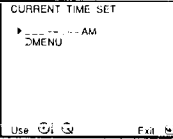
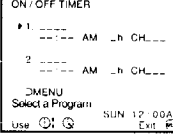
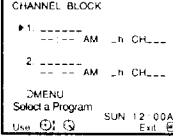
<p>DAYLIGHT SAVING <i>Automatically adjusts the time.</i></p>	<p>Spring: Select YES to compensate for Daylight Saving Time. The current time automatically moves ahead one hour. Fall: Select NO at the end of Daylight Saving Time. The current time moves back one hour.</p>
<p>CURRENT TIME SET <i>Necessary for the TIMER.</i></p>	<p>1 Press +, then press up or down on the joystick until the current day (MON-SUN) is displayed, and press +. 2 Press up or down on the joystick until the current hour (01-12) and AM/PM is displayed, and press +. 3 Press up or down on the joystick until the current minute (00-59) is displayed, and press +. The Clock has now started. Press MENU to exit.</p> 
<p>ON/OFF TIMER <i>Wake up or scheduled viewing.</i></p>	<p>1 Select the desired timer (1 or 2). 2 Press up or down on the joystick until the desired day (MON-SUN) or range of days (EVERY SUN-SAT or EVERY MON-FRI) is displayed, and press +. 3 Press up or down on the joystick until the time (hours and minutes) that you want the TV to remain on is displayed, and press +. 4 Press up or down on the joystick to set the time duration (maximum of 6 hours) and press +. TO CANCEL THE TIMER FUNCTION, PRESS RESET. 5 Press up or down on the joystick to select the desired channel and press +. The timer is now set. The TIMER indicator on your TV will be lit. Press MENU to exit. Performing AUTO PROGRAM will erase all TIMER settings.</p> 
<p>CHANNEL BLOCK <i>Prevent access to certain channels.</i></p>	<p>You will be able to block two channels for a period of up to 12 hours. FOLLOW STEPS 1-5 OF "ON/OFF TIMER" ABOVE To erase your CHANNEL BLOCK settings, press RESET while in the CHANNEL BLOCK window. Performing AUTO PROGRAM will erase your CHANNEL BLOCK settings.</p> 

Adjusting your SET UP (menus) (continued)

Using the SET UP Menu

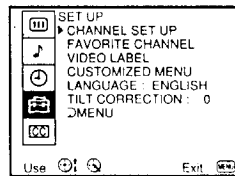

For detailed information on using the remote control to modify menu settings, refer to "Learning Menu Selection" on page 22.

To select the SET UP menu:

Display → Highlight → Select

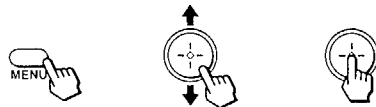

If any menu items are "grayed out", press the ANT button on your remote control so that a channel number appears.

CHANNEL SET UP

Basic set up options for viewing

With the CHANNEL SET UP window open:

- 1 Use the joystick to select the feature you want to change.
- 2 Press \oplus to access the feature.

CABLE: Select ON if your TV is connected to a cable system. (AUTO SET UP will set CABLE to OFF automatically if a cable channel is not available)

CHANNEL FIX: Press up or down on the joystick to set the TV's input to one of the following options:

2-6: When the cable box is connected to the VHF/UHF input and you do not want to switch to AUX mode. Press DBS/CABLE (FUNCTION) and then CH +/- to change channels.

AUX 2-6: When a cable box is connected to AUX and a cable or antenna is connected to VHF/UHF. You can alternate between the two inputs by pressing ANT.

VIDEO 1: When you have connected video equipment (e.g. AV receiver) and you want the TV input fixed to it. You will be able to alternate between video sources.

OFF: When you want to switch CHANNEL FIX off.

If the TV is in the AUX mode when you turn CHANNEL FIX off, press ANT to return to regular (CATV) mode.

TIMER and CHANNEL BLOCK settings are erased when CHANNEL FIX is set.

AUTO PROGRAM: Signals the TV to automatically program all receivable channels.

CHANNEL ERASE/ADD: With the CHANNEL ERASE/ADD window open:

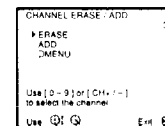



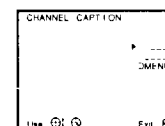

- 1 Place the cursor next to ERASE or ADD.
- 2 Select the desired channel using CH +/-, or by selecting with the 0-9 buttons and pressing ENTER.
- 3 Press \oplus .

CHANNEL CAPTION: With the CHANNEL CAPTION window open:

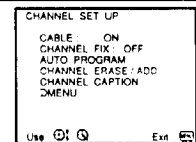

- 1 Press \oplus and then press up or down on the joystick to select the desired channel, and press \oplus again.
- 2 Press up or down on the joystick to display the first letter or number of the caption and press \oplus to select it. (Repeat until up to four digits are selected)
- 3 Press \oplus . To erase a Caption, press RESET.



<p>FAVORITE CHANNEL <i>User's favorite channels</i></p>	<p>The FAVORITE CHANNEL feature provides a multi-picture presentation to enable direct channel selection. (for details on how to set up this feature, see "Setting and Selecting FAVORITE CHANNEL" on page 28)</p>
<p>VIDEO LABEL <i>Easy recognition of connected equipment (e.g. DBS, VHS, etc.).</i></p>	<p>This feature allows you to label each input mode so that you can easily identify the connected equipment (e.g. you can label VIDEO 1 IN as VHS).</p> <ol style="list-style-type: none"> 1 Press up or down on the joystick to select the input mode you want to label and press . 2 Press up or down on the joystick to select the label and press . <p>VIDEO LABEL Options: VIDEO 1: VHS, 8mm, BETA, LD, GAME, DBS, DVD, WEB, RECEIVER, SKIP VIDEO 2/3: VHS, 8mm, BETA, LD, GAME, DBS, DVD, WEB, SKIP VIDEO 4: DVD, SKIP</p> <p><i>If you select SKIP, your TV will skip this connection when you scan through video sources using the TV/VIDEO button. When VIDEO LABEL is set to WEB, the screen will darken, creating an ideal picture for WebTV viewing.</i></p>
<p>CUSTOMIZED MENU <i>Frequently used menu items</i></p>	<p>Use this feature to create a custom menu which contains only those functions that you use most. (for details on how to set up this feature, see "Customizing the Menu" on page 31)</p>
<p>LANGUAGE <i>User's preferred language</i></p>	<p>Select from available languages to display all menus in your language of choice.</p>
<p>TILT CORRECTION <i>Adjust your picture.</i></p>	<p>(KV-35XBR48, 35XBR88, 37XBR48M only) Use this feature to correct any tilt of the picture. Press up or down on the joystick to select a correction between +5 and -5 and press .</p>



Adjusting your SET UP (menus) (continued)

Setting and Selecting FAVORITE CHANNEL

The FAVORITE CHANNEL feature provides a multi-picture presentation to enable direct channel selection.

Your FAVORITE CHANNEL options can be set automatically or manually.

The factory setting for FAVORITE CHANNEL is AUTO. When FAVORITE CHANNEL is set to AUTO, the last eight channels selected with the 0-9 buttons will be set as FAVORITE CHANNEL options.

Setting FAVORITE CHANNEL manually

- 1 Select FAVORITE CHANNEL from the SET UP menu.

The FAVORITE CHANNEL menu will appear. If you set CHANNEL CAPTION, captions (e.g. CNN, HBO) for the channels selected will display. (see "CHANNEL CAPTION" on page 26)

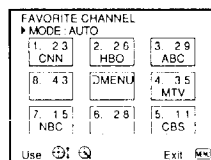

- 2 Select MODE and press \downarrow .

Press up or down on the joystick to display MANUAL and press \oplus .

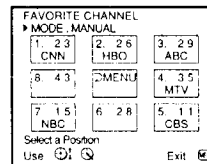

- 3 Press down on the joystick to select 1 and press \oplus .

Press up or down on the joystick to select a channel and press \oplus .

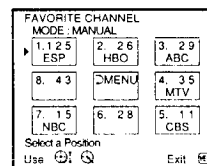

You have now selected a favorite channel for position 1.

- 4 Use the joystick to select other FAVORITE CHANNEL positions and program other favorite channels.

- 5 Press MENU when you are done.

Your favorite channels are now ready to use.

Resetting FAVORITE CHANNEL choices

You have the option of returning to the FAVORITE CHANNEL screen to adjust any of your favorite channel choices.

Simply proceed as described in "Setting FAVORITE CHANNEL manually" (skip step 2 if MANUAL is already selected). When you reach step 3, select the position you want to change and press \oplus . Press RESET to clear the channel for that position.

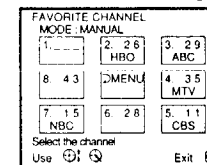

Press up or down on the joystick to select a new channel and press \oplus .

Press MENU when you are done.

Note:

- The FAVORITE CHANNEL feature is not available for the AUX input.

Using FAVORITE CHANNEL

You can use the FAVORITE CHANNEL feature to display multiple channels for direct selection.

1 Press  once.

The current channel will be displayed in the center of the screen surrounded by your eight favorite channels.



A yellow frame will appear to indicate current channel selection. The TV will continually update each of the surrounding pictures.

2 When you find a channel that you wish to view, use the joystick to move the yellow frame to that picture.

The sound of the picture surrounded by the yellow frame will be received.

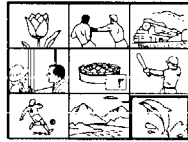

3 Press  to select the channel.

The selected channel will be retrieved and displayed for normal viewing.









Notes:

- You cannot move the yellow frame until all of the surrounding pictures appear.
- If one of the pictures received through FAVORITE CHANNEL is snowy, the entire screen may appear snowy. In this case, erase the snowy channel using CHANNEL ERASE/ADD. (see "CHANNEL SET UP" on page 26)

Adjusting your SET UP (menus) (continued)

Setting and Selecting FAVORITE CHANNEL (continued)

Using the Yellow Labeled Buttons for FAVORITE CHANNEL Operations. Some control buttons are located under the cover on the top of the remote control.	
FREEZE 	Press to freeze the center picture. Press again to cancel the frozen picture and resume normal FAVORITE CHANNEL viewing.
OFF 	Press to cancel the current operation and return to normal TV viewing.
Using the White Labeled Buttons for Center Picture Operations.	
TV/VIDEO 	Press to cycle the center picture through the video inputs. The surrounding channels will not change.
ANT 	Press to replace the center picture with a channel received through the AUX input. Press again to return to CATV input.
CH  or 0 - 9 or JUMP and ENTER 	Press to select the channel for the center picture. (see "Watching the TV" on pages 16-17)



REFER TO THE ILLUSTRATION OF THE REMOTE CONTROL ON THE INSIDE FRONT COVER OF THIS MANUAL AS YOU REVIEW THIS CHART

Customizing the Menu

You have the option of creating a custom menu including up to seven of the menu functions that you use most. You can select any menu items except those found in the SET UP menu. Once you define a custom menu, it will appear first whenever you press the MENU button.

Creating or changing a CUSTOMIZED MENU

- 1 Select CUSTOMIZED MENU from the SET UP menu.

The CUSTOMIZED MENU will appear.

- 2 Select CUSTOMIZE and press \oplus .

Press up or down on the joystick to display ON and press \oplus again.

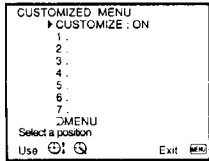

- 3 Press down on the joystick to select 1 and press \oplus .

The menu for selection will appear.



- 4 Locate the item you wish to include and press \oplus .

Grayed out items cannot be included in the CUSTOMIZED MENU.

The CUSTOMIZED MENU will return with your choice in position 1.

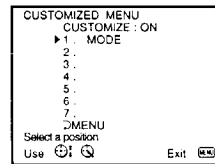

- 5 Repeat steps 3 and 4 to assign items to any or all of the remaining positions (2 - 7).

Items which you have already included will appear in green on the menu for selection.

Press MENU when you are done.

Your CUSTOMIZED MENU will now operate the same as any of the standard menus.

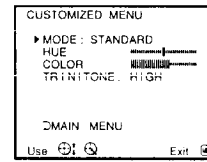

To Access the MAIN MENU from your CUSTOMIZED MENU

Select MAIN MENU in the CUSTOMIZED MENU and press \oplus .

To reset the CUSTOMIZED MENU choices

When the cursor points to CUSTOMIZE or position 1 to 7 in step 4 of "Creating or changing a CUSTOMIZED MENU", press RESET. All choices will be reset.

To cancel the CUSTOMIZED MENU function

- 1 Select MAIN MENU in the CUSTOMIZED MENU window and press \oplus .
- 2 Select the CUSTOMIZED MENU from the SET UP menu.
- 3 Select CUSTOMIZE and set it to OFF.

Operating Video Equipment

Setting the Manufacturer's Code

You can use the supplied remote control to operate Sony or non-Sony video equipment that has an infrared sensor.

- 1 Set the VTR 1/2/3/DVD/MDP switch to the position through which you would like to access the video equipment.

The following Sony equipment is preset to each position of the switch:

VTR1 (303)	Beta, ED Beta VCRs
VTR2 (302)	8 mm VCR
VTR3 (301)	VHS VCR
DVD/MDP (751)	DVD Player

- 2 Press CODE SET, VTR/DVD (FUNCTION), the 0-9 buttons to enter the manufacturer's code number (see the following chart), then press ENTER.

For example, to operate a Sony 8mm VCR:

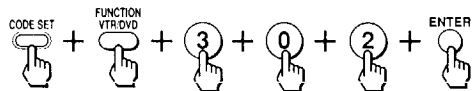

If the remote control doesn't work

- Try repeating the set up procedures using the other codes listed for your equipment.

VCR manufacturer code numbers

Manufacturer	Code
Sony	301, 302, 303
Aiwa	338, 344
Admiral (M. Ward)	327
Audio Dynamic	314, 337
Bell & Howell (M. Ward)	330, 343
Broksonic	319, 317
Canon	309, 308
Citizen	332
Craig	315, 302, 332
Criterion	315
Curtis Mathis	304, 338, 309
Daewoo	341, 312, 309
DBX	314, 336, 337
Dimensia	304
Emerson	319, 320, 316, 317, 318, 341
Fisher	330, 334, 335, 333
Funai	338
General Electric	329, 304, 309
Go Video	322
Goldstar	332
Hitachi	306, 304, 305, 338
Instant Replay	309, 308
JC Penney	309, 305, 304, 330, 314, 336, 337
JVC	314, 336, 337
Kenwood	314, 336, 332, 337
LXI (Sears)	332, 305, 333, 334, 330, 335, 338
Magnavox	308, 309, 310
Marantz	314, 336, 337
Marta	332
Memorex	309, 335
Minolta	305, 304
Mitsubishi/MGA	323, 324, 325, 326
Multitech	325, 338, 321
NEC	314, 336, 337
Olympic	309, 308
Optimus	327
Panasonic	308, 309, 306, 307
Pentax	305, 304
Philco	308, 309
Philips	308, 309, 310
Pioneer	308
Quasar	308, 309, 306
RCA/PROSCAN	304, 305, 308, 309, 311, 329, 312, 313, 310
Realistic	309, 330, 328, 335, 324, 338
Sansui	314
Singer	315
Samsung	322, 313, 321
Sanyo	330, 335
Scott	312, 313, 321, 335, 323, 324, 325, 326
Sharp	327, 328
Shintom	315
Signature 2000 (M. Ward)	338, 327
Sylvania	308, 309, 338, 310
Symphonic	338
SV2000	338
Tashiro	332
Tatung	314, 336, 337
Teac	314, 336, 338, 337
Technics	309, 308
Toshiba	312, 311
Wards	327, 328, 335, 331, 332
XR-1000	315

Yamaha 330, 314, 336, 337
Zenith 331

MDP manufacturer code numbers

Manufacturer	Code
Sony	701
Panasonic	704, 710
Pioneer	702

DVD Player manufacturer code numbers

Manufacturer	Code
Sony	751









Tips

- In some rare cases, you may not be able to operate your non-Sony video equipment with the supplied remote control. In this case, please use the equipment's own remote control.
- When you remove the batteries, the code number may revert to the factory setting.



To operate video equipment



- 1 Set the VTR1/2/3/DVD/MDP switch to the position through which you would like to access the video equipment.
- 2 Use the VCR/DVD/MDP buttons indicated in the following tables.

Operating a VCR using the remote control

To turn On/Off	Press VTR/DVD (POWER). [Green Button]
To select a channel	Press the 0 – 9 buttons.
To change channels	Press CH +/-.
To record	Press  (REC) while pressing  (upper left).
To play	Press  .
To stop	Press  .
To fast forward	Press  .
To rewind the tape	Press  .
To pause	Press  . Press again to resume normal playback.
To search the picture forward or backward	Press  or  during playback. Release to resume normal playback.
To change input mode	Press TV/VTR.





Operating an MDP using the remote control

To turn On/Off	Press VTR/DVD (POWER). [Green Button]
To play	Press  .
To stop	Press  .
To pause	Press  . Press again to resume normal playback.

To search the picture forward or backward	Press  or  during playback. Release to resume normal playback.
---	--

To search a chapter forward or backward	Press CH +/-.
---	---------------

Operating a DVD Player using the remote control

To turn On/Off	Press VTR/DVD (POWER). [Green Button]
To play	Press  .
To stop	Press  .
To pause	Press  . Press again to resume normal playback.
To step through different tracks of an audio disc	Press  to step forward or  to step backward.
To step through different chapters of a video disc	Press CH+ to step forward or CH- to step backward.
To display the Title menu	Press TITLE.
To display the DVD menu	Press DVD MENU.
To select tracks directly	Press 0-9 buttons.
To display the menu (Set up)	Press MENU.

Operating a Cable Box or DBS Receiver

Setting the Manufacturer's Code

You can program the supplied remote control to operate a cable box or DBS receiver.

Press CODE SET, DBS/CABLE (FUNCTION), the 0-9 buttons to enter the manufacturer's code number (see the following chart), then press ENTER.

For example, to operate a Sony DBS receiver:

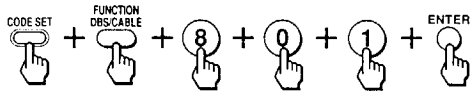

Manufacturer code numbers (cable box)

Manufacturer	Code
Hamlin/Regal	222, 223, 224, 225, 226
Jerrold/G. I.	201, 202, 203, 204, 205, 206, 207, 208, 218
Oak	227, 228, 229
Panasonic	219, 220, 221
Pioneer	214, 215
Scientific Atlanta	209, 210, 211
Tocom	216, 217
Zenith	212, 213

Manufacturer code numbers (DBS receiver)

Manufacturer	Code number
Sony	801 (preset code for remote control)
General Electric	802
RCA/PROSCAN	802

To operate the TV

Press TV (FUNCTION). Then use the TV control buttons to control the TV.

For more details on operating the cable box or DBS receiver

Refer to the operating instructions that come with the equipment.

If the remote control doesn't work

- First, try repeating the set up procedures using the other codes listed for your equipment.

Tips

- If more than one code number is listed, try entering them one by one until you come to the correct code for your equipment.
- If you enter a new code number, the code number you previously entered at that setting is erased.

- In some rare cases, you may not be able to operate your equipment with the supplied remote control. In this case, use the equipment's own remote control unit.
- Whenever you remove the batteries — to replace them, for example — if too much time is taken, the code numbers may revert to the factory setting and must be reset.

Troubleshooting

No picture (screen not lit), no sound

- Make sure the power cord is plugged in.
- Operate with the buttons on the TV and the remote control.
- Check to see if the TV/VIDEO setting is correct: when watching TV, set to TV, and when watching video tapes, set to VIDEO 1, 2, 3 or 4.
- Try another channel. It could be station trouble.
- Perform AUTO SET UP again using the SET UP button to return to the factory preset condition. (see "To perform AUTO SET UP again" on page 15)

Remote control does not operate

- Batteries could be weak. Replace the batteries.
- Press TV (FUNCTION) when operating your TV.
- Make sure the TV's power cord is connected securely to the wall outlet.
- Locate the TV at least 3-4 feet away from fluorescent lights.
- Check the S-Link connection. (see "Using the S-Link function" on page 11)
- Check the polarity of the batteries.

Dark, poor or no picture (screen lit), good sound

- Adjust PICTURE in the VIDEO menu. (see "PICTURE" on page 23)
- Adjust BRIGHTNESS in the VIDEO menu. (see "BRIGHTNESS" on page 23)
- Check antenna/cable connections.
- Perform AUTO SET UP again using the SET UP button to return to the factory preset condition. (see "To perform AUTO SET UP again" on page 15)
- When VIDEO LABEL is set to WEB, the screen will darken, creating an ideal picture for WebTV viewing. (see "VIDEO LABEL" on page 28)

Good picture, no sound

- Press MUTING so that "MUTING" disappears from the screen. (see "MUTING" on page 16)
- Check the MTS setting in the AUDIO menu. (see "MTS" on page 24)
- Make sure SPEAKER is set to ON in the AUDIO menu. (see "SPEAKER" on page 24)
- Perform AUTO SET UP again using the SET UP button to return to the factory preset condition. (see "To perform AUTO SET UP again" on page 15)

Cannot receive upper channels (UHF) when using an antenna

- Make sure CABLE is OFF in the SET UP menu. (see "CHANNEL SET UP" on page 26)
- Use AUTO PROGRAM to add receivable channels that are not presently in TV memory. (see "CHANNEL SET UP" on page 26)

No color

- Adjust the COLOR in the VIDEO menu. (see "COLOR" on page 23)
- Black and white programs cannot be seen in color.
- Perform AUTO SET UP again using the SET UP button to return to the factory preset condition. (see "To perform AUTO SET UP again" on page 15)

Only snow and noise appear on the screen

- Check the CABLE setting in the SET UP menu. (see "CHANNEL SET UP" on page 26)
- Check the antenna/cable connections.
- Make sure the channel is broadcasting programs.
- Press ANT to change the input mode. (see "ANT" on page 17)

Dotted lines or stripes

- Adjust the antenna.
- Move the TV away from noise sources such as cars, neon signs, or hair-dryers.

Troubleshooting (continued)

TV is fixed to one channel

- Try turning CHANNEL FIX off. (see "CHANNEL SET UP" on page 26)
- Use AUTO PROGRAM to add receivable channels that are not presently in the TV memory. (see "CHANNEL SET UP" on page 26)

Double images or ghosts

- Use a highly directional outdoor antenna or a cable (when the problem is caused by reflections from nearby mountains or tall buildings).

Cannot operate menu

- If the item you want to choose appears in gray, you cannot select it. Press TV/VIDEO correctly.

The electronic console doors do not operate properly (KV-35XBR88 only)

- Make sure the AUTO ACCESS switch is set to ON.
- Remove any dirt or dust from the ultrasonic sensor.
- The clothes you are wearing may be absorbing the ultrasonic waves emitted by the sensor. Try passing a different type of surface before the sensor.

Cannot receive any channels when using cable TV

- Make sure CABLE is ON in the SET UP menu. (see "CHANNEL SET UP" on page 26)
- Use AUTO PROGRAM to add receivable channels that are not presently in TV memory. (see "CHANNEL SET UP" on page 26)

Cannot gain enough volume when using a cable box

- Increase the volume at the cable box. Then press TV (FUNCTION) and adjust the TV's volume.

TV malfunctions when using the S-Link function

- Make sure the TV's power cord is connected securely to the wall outlet.
- Check the S-Link connection. (see "Using the S-Link function" on page 11)

CHANNEL INDEX does not display all available channels

- Make sure CABLE is ON in the SET UP menu. (see "CHANNEL SET UP" on page 26)
- Use AUTO PROGRAM to add receivable channels that are not presently in the TV memory. (see "CHANNEL SET UP" on page 26)

FAVORITE CHANNEL does not display your choices

- Verify that MODE is set to MANUAL in the FAVORITE CHANNEL menu. (see "Setting FAVORITE CHANNEL manually" on page 28)

The CUSTOMIZED MENU does not appear when you press MENU

- Verify CUSTOMIZE is set to ON in the CUSTOMIZED MENU window. (see "Creating or changing a CUSTOMIZED MENU" on page 31)
- If no items are selected in the CUSTOMIZED MENU, CUSTOMIZE is set to OFF automatically. (see "Creating and changing a CUSTOMIZED MENU" on page 31)

Some video sources do not appear when you press TV/VIDEO

- Ensure that VIDEO LABEL is not set to SKIP. (see "VIDEO LABEL" on page 27)

Recording through MONITOR OUT does not function properly when recording in PIP or P&P mode

- MONITOR OUT will not record both images in PIP or P&P. Only the main picture will be recorded.
- If you are recording the main picture and you switch to the sound of the sub picture using the AUDIO button, the main picture will be recorded with sound from the other program.

To reset the TV to factory settings

- First, turn the TV on. Then, while pressing the RESET button on the remote control, press the POWER button on the TV. The TV will turn itself off, then back on. When the TV turns on again, all settings will be reset, and the EASY SETUP GUIDE will appear.

Specifications

	KV-	32XBR48	34XBR48C	35XBR48	35XBR88	37XBR48M
Power requirements	120 V, 60 Hz	220 V, 50/60 Hz	120 V, 60 Hz	120 V, 60 Hz	120 V, 60 Hz	120 V, 60 Hz
Number of inputs/outputs						
Video ¹⁾	3	3	3	3	3	3
S Video ²⁾	2	2	2	2	2	2
Audio ³⁾	4	4	4	4	4	4
Audio out ⁴⁾	1	1	1	1	1	1
Monitor out ¹⁾	1	1	1	1	1	1
TV out ¹⁾	1	1	1	1	1	1
S-Link
Y, B-Y, R-Y ⁵⁾	1	1	1	1	1	1
Speaker output (W)	15W x 2	15W x 2	15W x 2	15W x 2	15W x 2	15W x 2
Power consumption (W)						
In use (Max.)	195W	195W	198W	198W	198W	198W
In standby	15W	17W	15W	15W	15W	15W
Dimensions (W/H/D)						
(mm)	864 x 656 x 606 mm	864 x 656 x 606 mm	936 x 706.5 x 629 mm	936 x 1201.5 x 699.5 mm	936 x 706.5 x 629 mm	936 x 706.5 x 629 mm
(in.)	34 1/16 x 25 7/8 x 23 7/8 in.	34 1/16 x 25 7/8 x 23 7/8 in.	36 7/8 x 27 7/8 x 24 25/32 in.	36 7/8 x 47 3/8 x 27 9/16 in.	36 7/8 x 27 7/8 x 24 25/32 in.	36 7/8 x 27 7/8 x 24 25/32 in.
Mass (kg)	72 kg	72 kg	90 kg	125 kg	90 kg	90 kg
(lbs)	158 lbs 12 oz	158 lbs 12 oz	198 lbs 7 oz	276 lbs 0 oz	198 lbs 7 oz	198 lbs 7 oz

- ¹⁾ 1 Vp-p, 75 ohms unbalanced, sync negative
²⁾ Y: 1 Vp-p, 75 ohms unbalanced, sync negative
 C: 0.286 Vp-p (Burst signal), 75 ohms
³⁾ 500 mVrms (100% modulation), Impedance: 47 kilohms
⁴⁾ More than 408 mVrms at the maximum volume setting (variable)
 More than 408 mVrms (fix)
 Impedance: 50 kilohms

- ⁵⁾ Y: 1.0 Vp-p, 75 ohms, sync negative
 B-Y: 0.7 Vp-p, 75 ohms
 R-Y: 0.7 Vp-p, 75 ohms

Television system

American TV standard

Channel coverage

VHF: 2-13/UHF: 14-69/CATV: 1-125

Picture tube

Hi Black Trinitron® tube

Antenna

75 ohm external terminal for VHF/UHF

Visible Screen size

32-inch picture measured diagonally (KV-32XBR48, 34XBR48C)

35-inch picture measured diagonally (KV-35XBR48, 35XBR88, 37XBR48M)

Actual Screen size

34-inch picture measured diagonally (KV-32XBR48, 34XBR48C)

37-inch picture measured diagonally (KV-35XBR48, 35XBR88, 37XBR48M)

Supplied accessories

Remote control RM-Y144 (1)

Batteries (2) size AA (R6)

Optional accessories

Connecting cables

RK-74A, RK-G69HG, VMC-10HG, VMC-720M, VMC-810S/820S, YC-15V/30V

TV Stand SU-32XBR48

KV-32XBR48, 34XBR48C

TV Stand SU-35XBR48

KV-35XBR48, 37XBR48C

U/V mixer EAC-66

Design and specifications are subject to change without notice.



SRS (●)* (SOUND RETRIEVAL SYSTEM)

The SRS (●)* (SOUND RETRIEVAL SYSTEM) is manufactured by Sony Corporation under license from SRS Labs, Inc. It is covered by U.S. Patent No. 4,748,669. Other U.S. and foreign patents pending.

The word 'SRS' and the SRS symbol (●) are registered trademarks of SRS Labs, Inc.

Index

A			
AC power cord	2	CATV cable	3
AC outlets	13	Coaxial cable	2, 4, 5
Adjusting your SET UP	22	Console box operation	13
ANT	17	CH +/-	16
Antenna cable	3	CHANNEL BLOCK	25
Antenna connector	2	CHANNEL CAPTION	26
AUDIO button	18	CHANNEL ERASE/ADD	26
AUDIO menu operations 	24	CHANNEL FIX	26
AUDIO OUT	24	CHANNEL INDEX	20
BALANCE	24	CHANNEL SET UP	26
BASS	24	AUTO PROGRAM	26
EFFECT	24	CABLE	26
MTS	24	CHANNEL CAPTION	26
SPEAKER	24	CHANNEL ERASE/ADD	26
TREBLE	24	CHANNEL FIX	26
AUDIO OUT	24	COLOR	23
Audio/Video cable	2	COLOR CORRECTION	23
AUTO PROGRAM	26	CONTROL S feature	12
AUTO SET UP	15	Connecting TV to	
AUX Hookup	3, 17	antenna	2
B		audio system	7
BALANCE	24	AV receiver	7
BASS	24	cable	3
Battery installation	14	cable box and cable	3
BRIGHTNESS	23	camcorder	10
C		DBS receiver	6
CABLE	26	DBS receiver and VCR	6
Cable box	3, 5	DVD Player	9
operation	34	two VCRs	8
Caption Vision	17	VCR	4
		CURRENT TIME SET	25
		CUSTOMIZED MENU	31
		D	
		DAYLIGHT SAVING	25
		DBS receiver operation	34
		DVD Player	
		connection	9
		operation	33
		E	
		EASY SETUP GUIDE	15
		Editing using MONITOR OUT	8
		EFFECT	24
		F, G	
		Factory settings	23, 24
		FAVORITE CHANNEL	
		Setting	28
		Selecting	29
		FREEZE button	16, 19
		H, I	
		Hook Ups	2
		HUE	23
		J, K	
		Joystick	14
		JUMP button	16
		L	
		LANGUAGE selection	15, 27
		Learning menus	22
		M, N	
		MDP operation	33
		Menu selection	22

MODE			
DYNAMIC	23		
MOVIE	23		
SPORTS	23		
STANDARD	23		
MONITOR OUT	8		
MONO	24		
MTS			
MONO	24		
SAP	24		
STEREO	24		
MUTING button	16		
O			
On Line Help	14		
ON/OFF TIMER	25		
P, Q			
PICTURE	23		
Picture and Picture (P&P)	18		
Picture-in-Picture (PIP)	18		
PIP/P&P operations			
AUDIO	18		
CH+/-	19		
CHANNEL INDEX	19		
FREEZE	19		
POSITION	19		
SWAP	19		
TV/VIDEO	18		
R			
Remote control	16		
Function buttons	16, 17		
Graphic Illustration	(inside cover)		
S			
SAP	24		
S-Link cable	2		
S-Link connector	11		
S-Link function	11		
S Video cable	2		
Safety	1		
Select buttons	14		
Adjusting sliders	14		
SET UP menu operations 	26, 27		
CHANNEL SET UP	26		
CUSTOMIZED MENU	27		
FAVORITE CHANNEL	27		
LANGUAGE	27		
TILT CORRECTION	27		
VIDEO LABEL	27		
Setting Up the TV Automatically	15		
SHARPNESS	23		
SKIP	27		
SLEEP button	17		
Sliders	14		
SPEAKER			
ON	24		
OFF	24		
Specifications	37		
Splitter	5		
SRS	24		
SWAP button	19		
SYSTEM OFF	17		
T, U			
TILT CORRECTION	27		
TIMER menu operations 	25		
CHANNEL BLOCK	25		
CURRENT TIME SET	25		
DAYLIGHT SAVING	25		
ON/OFF TIMER	25		
TREBLE	24		
TRINITONE	23		
Troubleshooting	35, 36		
TV (FUNCTION) button	16		
TV POWER button	16		
TV/VIDEO button	17		
V, W			
VCR	4, 5, 8		
VCR manufacturer code numbers	32		
VCR operation	33		
Video Equipment Operation	32		
VIDEO LABEL	27		
VIDEO menu operations 	23		
BRIGHTNESS	23		
COLOR	23		
COLOR CORRECTION	23		
HUE	23		
MODE	23		
PICTURE	23		
SHARPNESS	23		
TRINITONE	23		
VOL +/-	16		
VTR	32		
X			
XDS	17		
Y, Z			
Y/B-Y/R-Y	9		

Printed in U.S.A.