

**Operating
Guide
and
Warranty**



**The Quality Goes In Before
the Name Goes On[®]**

SENTRY 2
Monaural Color TV
with Remote Control
and Closed Captions

Return the Product
Registration Card,
and your TV could
be free!



WARNING

**RISK OF ELECTRIC SHOCK
DO NOT OPEN**



WARNING: TO REDUCE THE RISK OF ELECTRIC SHOCK DO NOT REMOVE COVER (OR BACK). NO USER SERVICEABLE PARTS INSIDE. REFER TO QUALIFIED SERVICE PERSONNEL.

TO PREVENT FIRE OR SHOCK HAZARDS, DO NOT EXPOSE THIS PRODUCT TO RAIN OR MOISTURE.



The lightning flash with arrowhead symbol, within an equilateral triangle, is intended to alert the user to the presence of uninsulated "dangerous voltage" within the product's enclosure that may be of sufficient magnitude to constitute a risk of electric shock to persons.



The exclamation point within an equilateral triangle is intended to alert the user to the presence of important operating and maintenance (servicing) instructions in the literature accompanying the appliance.

Safety Tips

Refer to the "Safety Tips" booklet that came with your product for important safety considerations.

Note to Cable TV System Installer

This reminder is provided to call the cable TV system installer's attention to Article 820-40 of the NEC that provides guidelines for proper grounding and, in particular, specifies that the cable ground shall be connected to the grounding system of the building, as close to the point of the cable entry as practical.

Power-Cord Polarization

This product is equipped with a polarized alternating-current line plug (a plug having one blade wider than the other.) This plug will fit into the power outlet only one way. This is a safety feature. If you are unable to insert the plug fully into the outlet, try reversing the plug. If the plug should still fail to fit, contact your electrician to replace your obsolete outlet. Do not defeat the safety purpose of the polarized plug.

CAUTION

To prevent electric shock, match wide blade of plug to wide slot, fully insert.

ATTENTION

Pour éviter les chocs électriques, introduire la lame la plus large de la fiche dans la borne correspondante de la prise et pousser jusqu'au fond.

CONTENTS

INTRODUCTION

Welcome	ii
Installation Considerations	ii

THE FIRST TIME YOU OPERATE YOUR TV

Step 1. Make Basic Connection to TV	1-1
Step 2. Connect the Power	1-3
Step 3. Turn TV On	1-3
Step 4. Use Auto Search	1-3
Step 5. Use Other Options	1-3

GETTING TO KNOW YOUR TV

Front Panel Controls and Indicators	2-1
---	-----

GETTING TO KNOW YOUR REMOTE CONTROL

Operation	3-1
Preparation for Use	3-2
Installing Batteries	3-2

OPERATING YOUR TV

Basic TV Operations	4-1
Sleep Timer (Remote Control Only)	4-1

VIEWING CLOSED CAPTIONS

Introduction	5-1
Characteristics of Captions	5-1

ON-SCREEN MENUS

Available Menus	6-1
Summary of Menu Items	6-1
Basic Menu Operations	6-2

SETUP MENU

Auto Search	7-1
Fav. (Favorite) Channels	7-2
Band Select	7-2
AFC Mode	7-3
Time Set	7-3

VIDEO MENU

Contrast	8-1
Brightness	8-1
Color	8-1
Tint	8-1
Sharpness	8-1
Video Sentry	8-1

MAINTENANCE AND TROUBLESHOOTING

Caring for Your TV	9-1
Extended Absence	9-1
TV Picture Interference	9-1
Before Calling for Service	9-2

Product Registration Card

Recommended Accessories for Your Television

Your Zenith Warranty

INTRODUCTION

WELCOME

Welcome into the family of Zenith Color Television owners. This guide provides instructions on how to operate your new TV. It is supplemented by a booklet containing Safety Tips. We urge you to read these publications carefully so that you will receive full enjoyment from your new Zenith TV for many years to come.

Your new Zenith TV has been designed and built to give you the very best in quality, features and performance. There are approximately 75 regional Zenith distributors and thousands of distributor-approved Zenith service centers throughout the U.S. and Canada who can attend promptly and effectively to ordinary service needs.

If you should have an unusual performance or service problem that cannot be satisfactorily resolved by your distributor-approved Zenith service center, contact the regional Zenith distributor in your area, or write:

Zenith Electronics Corporation
Customer Service Department
1900 N. Austin Avenue
Chicago, Illinois 60639-5079
Telephone: (312) 745-5152
Mon-Fri, 8:00 a.m. - 4:30 p.m. Central Time

Send the model number, serial number, and date of purchase or original installation, with a full explanation of the problem and the service history. We will welcome the opportunity to look into your specific question or problem and to be of assistance in resolving it promptly.

The model and serial numbers of your new TV are located on the back of the TV cabinet. For your future convenience and protection, we suggest that you record these numbers here:

Model No. _____

Serial No. _____

INSTALLATION CONSIDERATIONS

Before you install your TV...



Ventilation — Proper ventilation keeps your TV running cool. Air circulates through perforations in the back and bottom of the cabinet. Do not block these vents or you will shorten the life of your TV.



Power Source — Your TV is designed to operate on normal household current, 120 volt 60 Hertz AC. Do not attempt to operate it on DC current.



Power Cord — Your power cord has a polarized plug as required by Underwriters' Laboratories. It has one regular blade and one wide blade and fits only one way into a standard electrical outlet. If the blades will not enter either way, your outlet is very old and non-standard. A new outlet should be installed by a qualified electrician.



Safe Operation — Your TV is manufactured and tested with your safety in mind. However, unusual stress caused by dropping or mishandling, exposure to flood, fire, rain or moisture, or accidental spilling of liquids into the TV, can result in potential electrical shock or fire hazards. If this happens, have your TV checked by a service technician before using it again.

Please read and observe each safety point in the "Safety Tips" folder when installing and using your TV.

FIXED PATTERN DISPLAY CAUTION — If you use your TV for video games, teletext or other fixed displays, avoid setting the BRIGHTNESS control for an excessively bright picture. A bright, fixed pattern, if used for long periods of time, can result in a permanent imprint on the TV picture tube. You can reduce this possibility by alternating the use of the fixed pattern display with normal TV picture viewing, by turning down the CONTRAST control for sustained fixed pattern use, and by turning off the fixed pattern display when not in use.

PLUGGING IN YOUR TV — Be sure to plug your TV into an "unswitched" AC power source. The "switched" AC outlets found on some video equipment will not continue supplying power to the TV once the equipment is turned off. If the power to the TV is interrupted, you will have to reset the clock in the TV to the current time.

THE FIRST TIME YOU OPERATE YOUR TV

STEP 1. MAKE BASIC CONNECTION TO TV

There are four basic hook ups to your TV; outdoor antenna (or master antenna) with or without VCR, and cable-TV system with or without VCR. Select the hook up that best fits your needs. See the following diagrams.

Your connection is made to the VHF-UHF/CABLE jack on the back of the TV. This jack accepts 75-ohm cable terminated in an F-type male connector. You may want to do the hook-up yourself, or call a TV service technician, or a cable company.

A. Antenna Connection to TV

If You Have a Round Antenna Wire:

Connect the 75-ohm round antenna wire into the VHF-UHF/CABLE jack on the TV.

If You Have a Flat, Twin-Lead Antenna Wire:

Use the 300/75 ohm adaptor included with the TV. Hook up the ends of the wire to the adaptor and plug it into the VHF-UHF/CABLE jack.

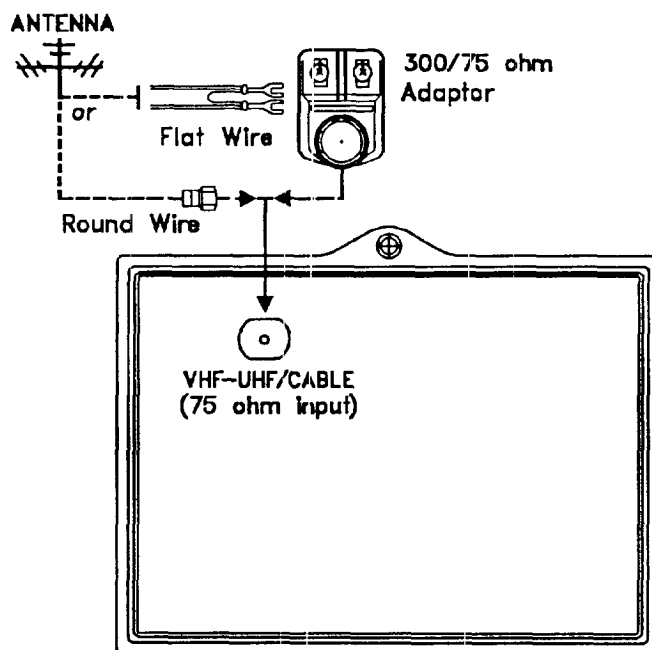

Connection Center on Back of TV

B. Antenna Connection to VCR and TV

1. Antenna Hook Up

Connect the 75-ohm round antenna wire into ANTENNA IN jack on VCR.

2. VCR Hook Up

Connect ANTENNA OUT wire from VCR into VHF-UHF/CABLE jack on TV.

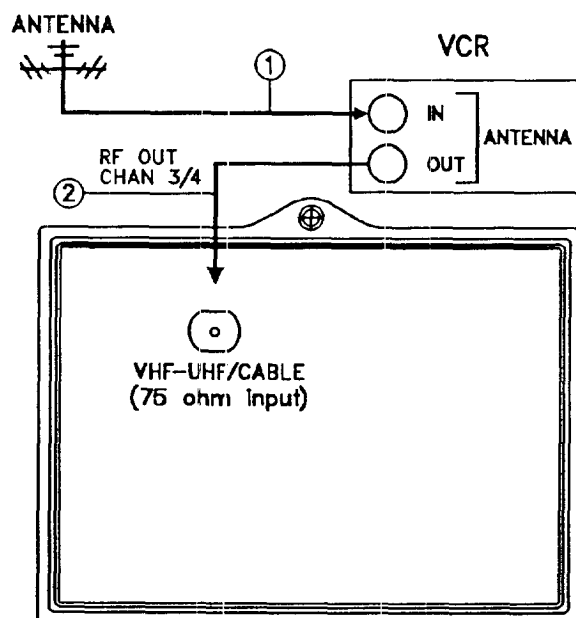

Connection Center on Back of TV

THE FIRST TIME YOU OPERATE YOUR TV

STEP 1. MAKE BASIC CONNECTION TO TV (CONTINUED)

C. Cable-TV Connection to TV

If You Have a Converter/Decoder Box:

Connect the 75-ohm output from the converter/decoder box into the VHF-UHF/CABLE jack on the TV.

If You Do Not Have a Converter/Decoder Box:

Connect the 75-ohm round cable-TV line directly to the VHF-UHF/CABLE jack on the TV.

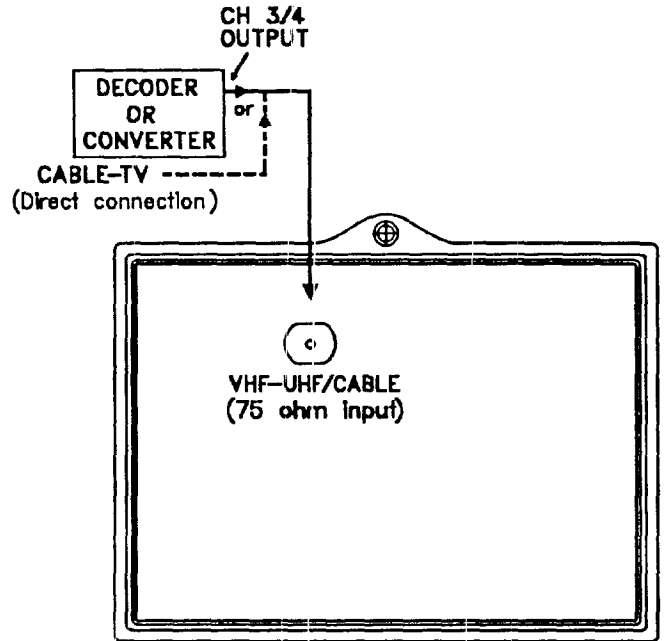

Connection Center on Back of TV

D. Cable-TV Connection to VCR and TV

1. Cable-TV Hook Up

Connect 75-ohm round cable-TV wire into ANTENNA IN jack on VCR.

2. VCR Hook Up

Connect ANTENNA OUT wire from VCR into VHF-UHF/CABLE jack on TV.

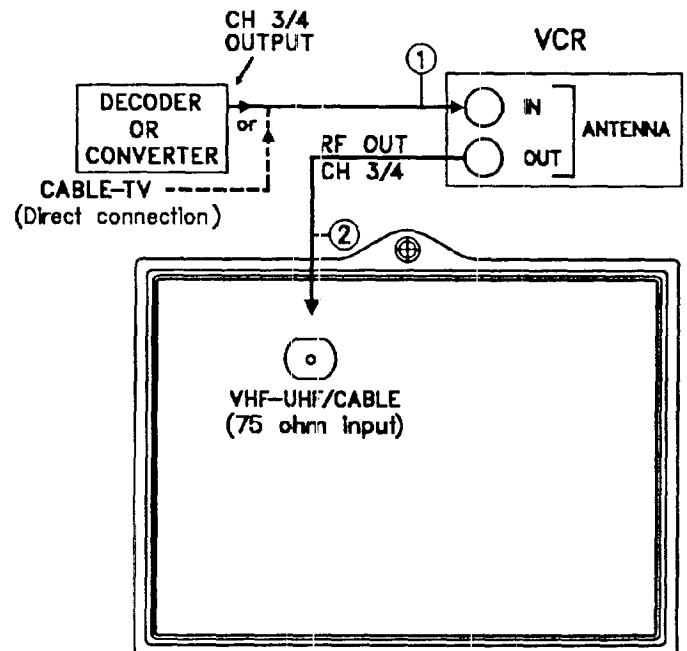

Connection Center on Back of TV

THE FIRST TIME YOU OPERATE YOUR TV

STEP 2. CONNECT THE POWER

Plug your TV into an unswitched AC power source.

The switched AC outlets found on some video equipment will not continue supplying power to the TV once the equipment is turned off. If the power to the TV is interrupted, you will have to set the clock in the TV to the current time.

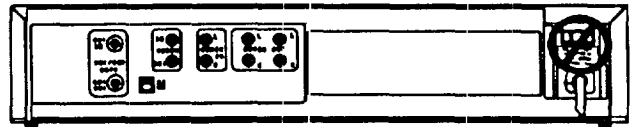

Do not plug TV into switched outlet on cable-TV decoder



Do not plug TV into switched outlet on a VCR

STEP 3. TURN TV ON

Turn the TV on by pressing OFF/ON on the front panel of the TV or on the remote control.

STEP 4. USE AUTO SEARCH

When your TV is first powered up you will see the AUTO SEARCH reminder display. AUTO SEARCH finds all available channels and stores them in memory for access by CHANNEL (CH) Up/Down. To activate AUTO SEARCH, press ADJUST (ADJ) Left/Right. When the search is complete, you can watch the TV program of your choice.

NOTES:

1. The AUTO SEARCH reminder display appears each time you turn on your TV until it has been used at least once.
2. Antenna or cable must be connected to TV before you use AUTO SEARCH.

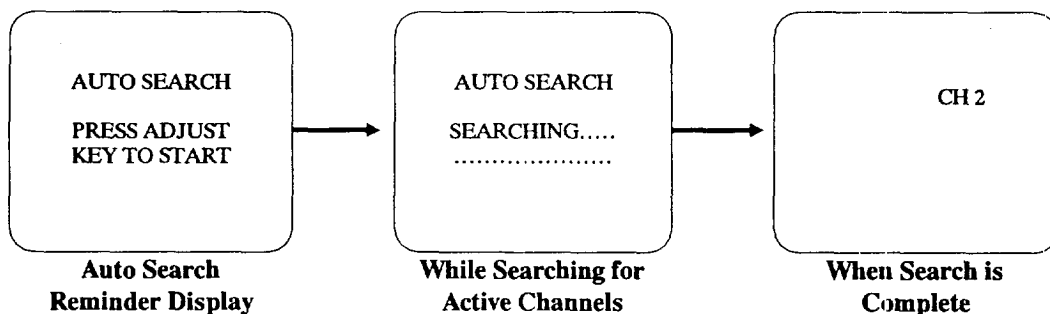

STEP 5. USE OTHER OPTIONS

You may want to consider using the following hook-up and set-up options:

- Program FAV. (Favorite) CHANNELS to customize the channels accessed by using CHANNEL (CH) Up/Down. Refer to the FAV. (Favorite) CHANNELS option of the "Setup Menu" section of this operating guide for details.
- Set the clock in the TV. Refer to the TIME SET option of the "Setup Menu" section of this operating guide for details.

GETTING TO KNOW YOUR TV

FRONT PANEL CONTROLS AND INDICATORS

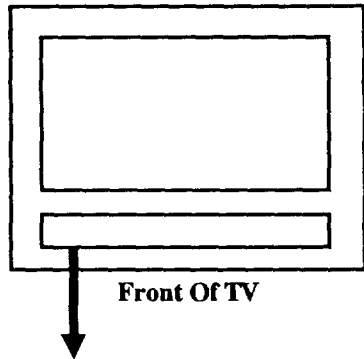

NOTE: Your TV may have either of the two control panels shown below:

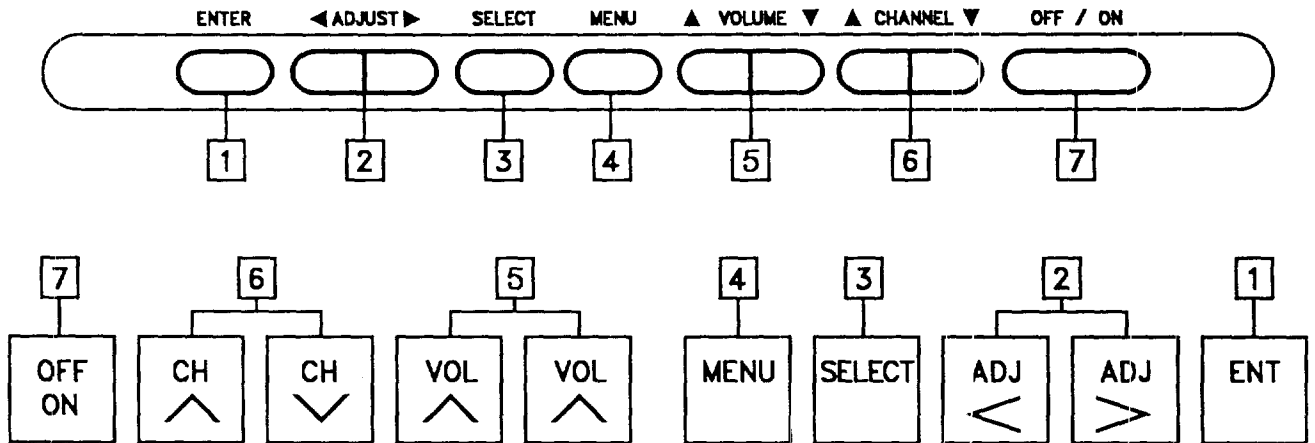

1. ENTER (ENT)

Press to see the Channel/Time display, or to remove any on-screen display or menu.

2. ADJUST (ADJ) Left/Right

Press during on-screen menu operations to see information/status display for selected option. Press again to adjust the selected menu option.

3. SELECT

Press during on-screen menu operations to select a menu option.

4. MENU

Press once to see a menu. Press repeatedly to sequence through the available menus.

5. VOLUME (VOL) Up/Down

Press to increase or decrease the sound level.

6. CHANNEL (CH) Up/Down

Press to select channels higher or lower than the channel being viewed. You can add channels to or delete channels from the scanning sequence stored in memory. See FAV. (Favorite) CHANNELS option of the "Setup Menu" section of this operating guide for channel programming information.

7. OFF/ON

Press to turn TV power ON or OFF.

GETTING TO KNOW YOUR REMOTE CONTROL

OPERATION

This remote control provides access to all on-screen menus, as well as, access to special features that can not be accessed by using the control panel on the TV.



For optimum performance, point the remote control toward your Zenith TV.

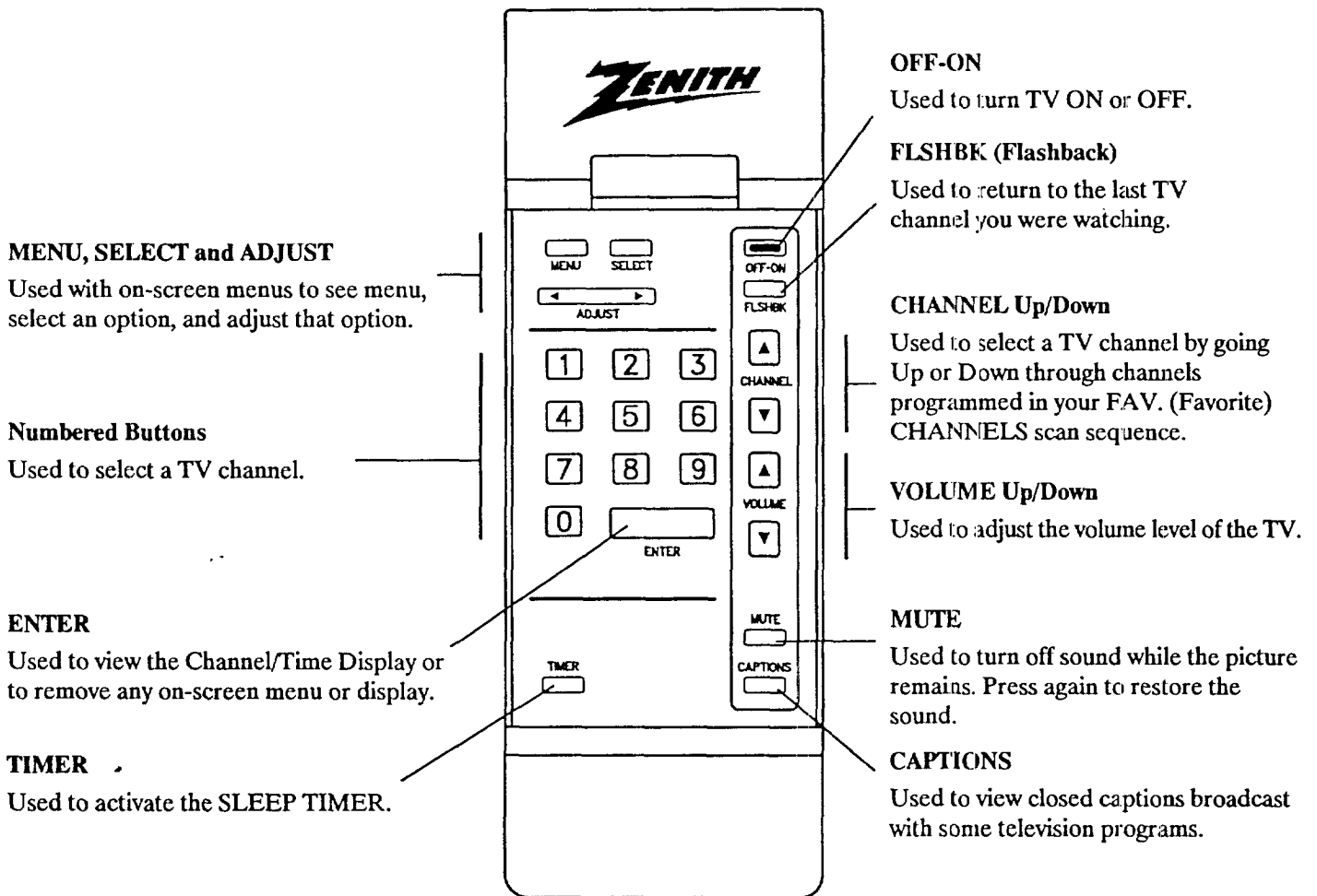

SC3390

GETTING TO KNOW YOUR REMOTE CONTROL

PREPARATION FOR USE

Batteries are provided with this remote, but you must install them before using the remote.

INSTALLING BATTERIES

When the effective operating range of your remote becomes noticeably shorter, replace the batteries with two (2) high quality, alkaline, size AAA batteries.

1. Remove the battery compartment cover, PUSH DOWN tab and PULL OUT from top.
2. Insert new batteries as indicated in the diagram inside the compartment.
3. Replace the cover by inserting the tab on the bottom of the cover into its housing. Snap the cover into position.

NOTES:

- Be careful not to place heavy objects on top of the remote control buttons. Prolonged accidental operation of the remote control will shorten battery life.
- If you do not use the remote control for a month or more, remove the batteries. Battery leakage can cause damage to the remote control.
- Zenith is not responsible for damage caused by such battery leakage.

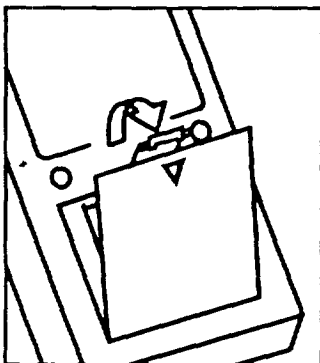

1.

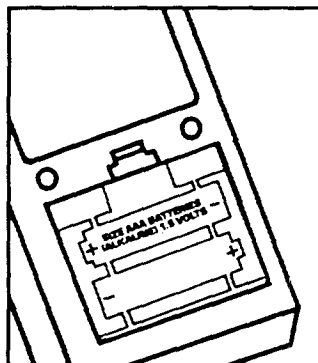

2.

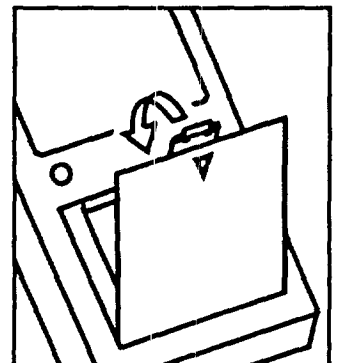

3.

OPERATING YOUR TV

BASIC TV OPERATIONS

Selecting Channels by Using Channel Up/Down: You may select a channel through channel scanning by using CHANNEL (CH) Up/Down either on the remote control or on the control panel of the TV. Only channels stored in your favorite channel scan sequence can be selected.

Selecting Channels by Using Direct Number Entry on Remote: Press the numbers corresponding to the channel desired, then press ENTER (ENT). Any channel in the band chosen can be selected through direct number entry.

FLSHBK (Flashback) on Remote: Press FLSHBK to return to the last TV channel you were watching.

Adjusting Volume/Muting Volume: You can adjust the volume of your set by using VOLUME (VOL) Up/Down. To mute the sound coming from your set, press MUTE on the remote control. To restore sound, press MUTE again.

After an Extended Power Outage: If you previously used AUTO SEARCH, you do not have to use it again unless you permanently changed the connectors to the TV. All of the channels previously found are stored in protected memory, and are not affected by a power outage. However, the clock must be reset to the current time.

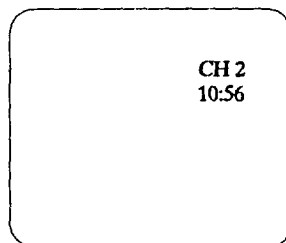

Channel/Time Display

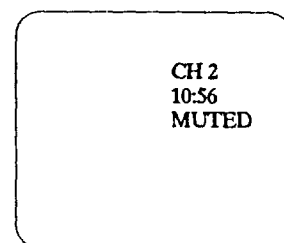

Channel/Time Display
While TV is Muted

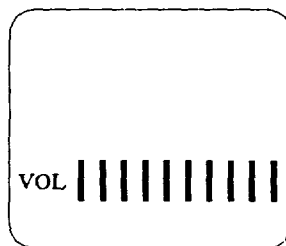

Volume Display

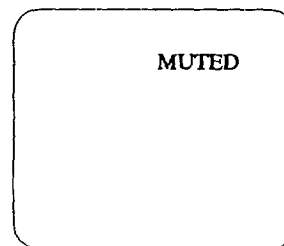

Mute Display

SLEEP TIMER (Remote Control Only)

You can program the TV to automatically shut off after a 15 minute period up to 4 hours, by using TIMER on the remote control.

To Set SLEEP TIMER

1. Press TIMER to see status display.
2. Press TIMER repeatedly until you reach desired shut-off time.

One minute before the TV shuts off, the GOOD NIGHT display appears on the screen. At this time you have a choice of the following three actions.

1. Do nothing. The TV will shut off in one minute.
2. Remove the GOOD NIGHT display by pressing ENTER (ENT). The TV will still shut off in one minute.
3. Delay the shut off by using TIMER to select a new shut off time.

To Cancel the SLEEP TIMER

You can cancel the SLEEP TIMER by setting the SLEEP TIMER status to OFF.

NOTE: The SLEEP TIMER resets to OFF when you turn off the TV.

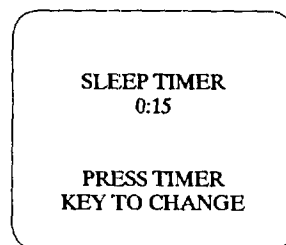

Sleep Timer Display

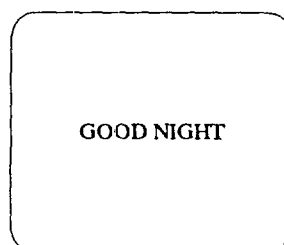

"Good Night" Display

VIEWING CLOSED CAPTIONS

INTRODUCTION

Your new television (TV) is able to decode and display the closed captions that are broadcast with some TV shows and provided on many pre-recorded video tapes. These captions can be subtitles for the hearing impaired, or translations into another language.

Look for a (CC) or similar sign in your TV schedule, or on the video tape cassette, which indicates that captions are provided.

The closed caption signal is recorded by all VCRs when recording a TV broadcast or copying a tape having closed captions.

To Access Captions

1. Press CAPTIONS on the remote control. One of the three information displays is shown, as follows.

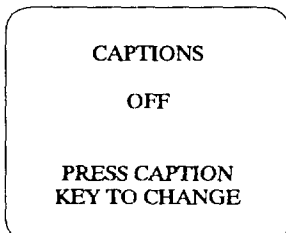

Captions Turned OFF

NOTE: Generally, closed captions are transmitted on CAPTION1. CAPTION2 is seldom used.

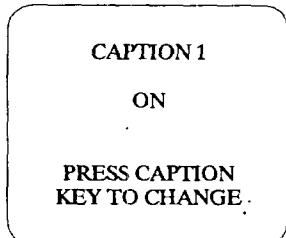

CAPTION1 Selected and Turned ON

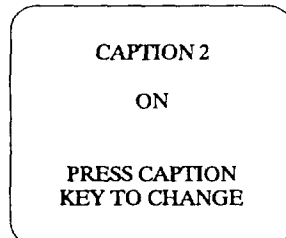

CAPTION2 Selected and Turned ON

2. Press CAPTIONS until the information display you desire is shown. The display disappears from the screen automatically in about 15 seconds, or you may press ENTER to remove the display immediately.

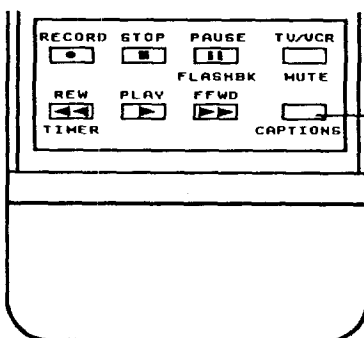

CAPTIONS
Press to select desired caption mode.

Typical Remote Control

(Your remote control may differ from unit shown.)

Automatic Operation

If caption signals are received, the captions appear in about 15 seconds. If no caption signal is received, no captions appear, but the TV remains in the captions mode. Captions appear when a caption signal is received. If you want to check the current captions mode of your TV, press CAPTIONS once. If you are receiving captions when you press CAPTIONS, the captions are interrupted and are not shown for about 15 seconds.

The captions mode you have selected remains in effect until you change it, even if you change TV channels, tune to a TV channel that is not broadcasting the caption signal, or turn the TV off. Sometimes captions are not seen when expected because the captions are not being sent, such as during a commercial break. Captions reappear when the caption signal is received again. If you change TV channels to another station that provides closed captions, the captions appear in about 15 seconds.

CHARACTERISTICS OF CAPTIONS

Captions appear on the TV screen in the position determined by the creator of the captions. Usually captions are positioned where they will least interfere with the visual action; at the top or the bottom of the screen. Newscasts generally provide three-line captions which "scroll" onto the screen. Dramas and comedies generally provide two- or three-line captions placed near the character who is speaking, so that the viewer can follow the dialogue.

Captions usually appear as white letters on a black background, but they may be in color. This TV shows underlined words or words in italics, such as titles, foreign words, and words with special emphasis as black words on a colored background. Words describing sounds are usually displayed as black words on a colored background and in parentheses. Words that are sung usually appear enclosed by musical notes.

It is not unusual for misspellings or unusual characters to appear in closed captions, especially those of live events. During a live broadcast, the captions are created as the program progresses, much as a court reporter transcribes a trial as it progresses. Live broadcasts do not allow time to correct spelling errors, etc.

NOTES:

- When captions are being shown, you may not see other on-screen displays, such as Volume or Mute displays.
- When Channel/Time or a menu is displayed, closed captions are not seen.
- Some cable-TV systems scramble their signals, which may interfere with the caption signal. Similar interference can be caused by some video copy protection systems.

ON-SCREEN MENUS

AVAILABLE MENUS

Your TV is menu operated, that is, adjustments that can be made to the TV appear on the screen in a list of choices you can make by using the controls on the front panel of the TV or on the remote control.

There are two menus: **SETUP** and **VIDEO**. These menus list everything you can adjust to your personal preference or needs.

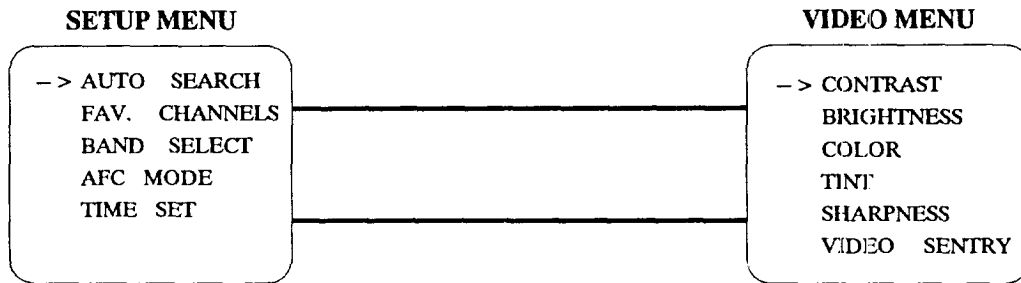

SUMMARY OF MENU ITEMS

SETUP Menu

AUTO SEARCH: Finds all available channels and stores them in memory for access by using CHANNEL (CH) Up/Down.

FAV. (Favorite) CHANNELS: Changes the list of active channels selected by using CHANNEL (CH) Up/Down.

BAND SELECT: Determines the operation of the channel tuner inside the TV.

AFC MODE (Automatic Frequency Control): Lets your TV compensate for variations in broadcast and cable TV frequencies.

TIME SET: Sets the clock in your TV to the correct time.

VIDEO Menu

CONTRAST: Adjusts the overall contrast and color level of the picture.

BRIGHTNESS: Adjusts the brightness level of black areas in the picture.

COLOR: Adjusts the intensity of the colors in the picture.

TINT: Adjusts the color of the flesh tones.

SHARPNESS: Adjusts the clarity for the clearest picture.

VIDEO SENTRY: Lets you decide if you want to use your own CUSTOM video settings, or the factory PRESET video settings.

ON-SCREEN MENUS

BASIC MENU OPERATIONS

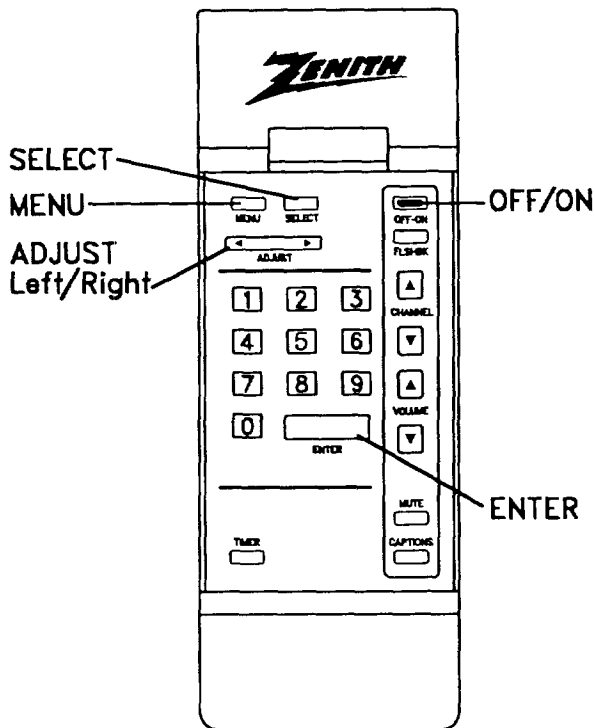

Typical Remote Control

1. To See a Menu or Change Menus

Press MENU repeatedly until the desired menu is shown. Example shows choosing the SETUP Menu.

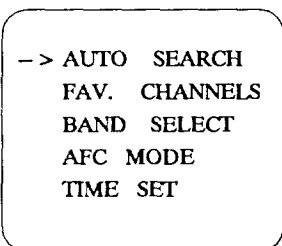

Choosing Setup Menu

2. To Select an Option/Feature on a Menu

Press SELECT (SEL) repeatedly until the desired option/feature is highlighted. Example shows selecting TIME SET.

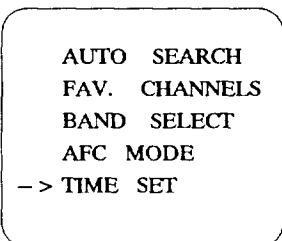

Selecting Time Set

3. To Access an Option/Feature for Adjustment

Press ADJUST (ADJ) Left/Right to access the selected option/feature to see its submenu or status display. Follow the instructions shown in the display. In most cases, you simply press ADJUST (ADJ) Left/Right a second time to adjust the accessed option/feature. You still see the status of the item change in the display.

NOTE: Do not change channels during menu operations unless instructed to do so in the procedures given in this operating guide.

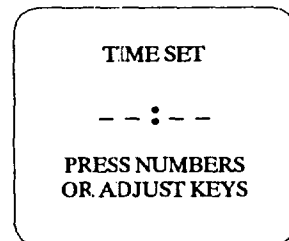

Time Set Display

4. To Access a Different Main Menu

Press MENU repeatedly until the desired menu is shown.

5. To Return to Normal Viewing

Press ENTER (ENT) or wait a few seconds and the TV will return automatically to normal operation.

Service Menus: In addition to the menus shown above, there are menus for factory and field servicing. Service menus are not intended for use by the owner.

If you inadvertently access a service menu, press ENTER (ENT) to return immediately to normal TV viewing.

SETUP MENU

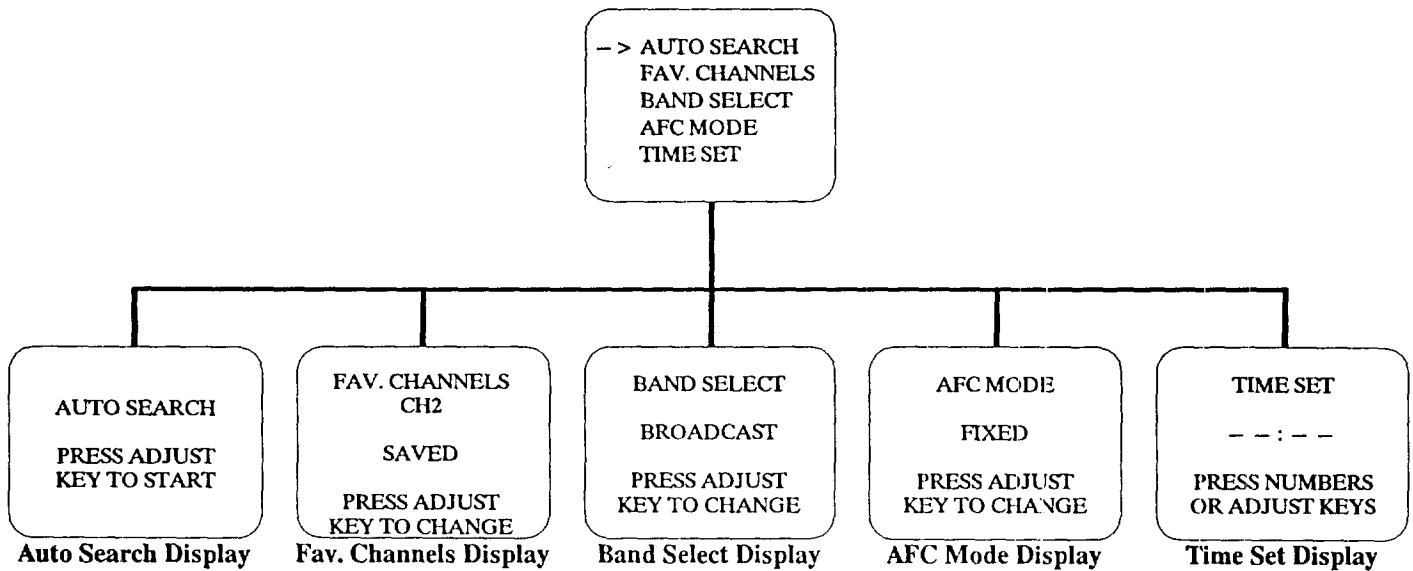

AUTO SEARCH

Purpose

Finds all available channels and stores them in memory for access by CHANNEL (CH) Up/Down.

Use AUTO SEARCH only when you first install your TV, or when you permanently change the connections to the TV. For example, when you replace the antenna with a cable-TV system.

Programmed channels are stored in protected memory, and are not affected by a power outage.

Before Using AUTO SEARCH

Connect and turn ON all external equipment, such as cable TV decoder, VCR, etc.

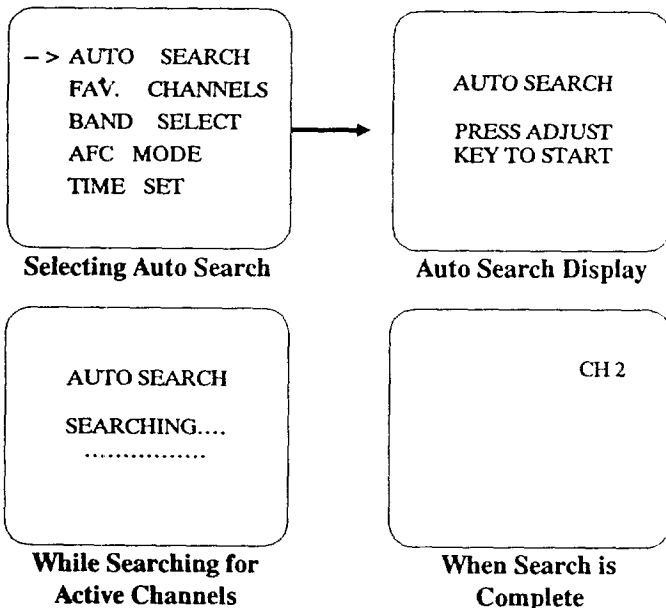

To Use AUTO SEARCH

1. AUTO SEARCH display should be shown on the TV if you followed the "Basic Menu Operation" given in the "On-Screen Menus" section.
2. Press ADJUST (ADJ) Left/Right to start the AUTO SEARCH, the status of the search is shown in the display. When the search is complete, you can watch the TV program of your choice.

When Some Channels Are Not Found

AUTO SEARCH finds only active channels and stores them in the Favorite Channel memory. You can add channels to those stored in memory by using the FAV. (Favorite) CHANNELS option.

If you have difficulty tuning some channels, you may have to manually change the BAND SELECT and AFC MODE. Refer to respective option for details.

When Only AUX Channel is Found

You may have used AUTO SEARCH without having a signal source (antenna, cable-TV, etc...) connected to the TV. In which case, no channels are stored in Favorite Channel memory, and the TV operates only on the AUX channel.

To resolve this condition, connect a signal source, turn signal source ON, if needed, and use AUTO SEARCH.

NOTE: AUX (Auxiliary) channel is operational only on TVs having separate video and audio inputs for VCR operations.

SETUP MENU

FAV. (Favorite) CHANNELS

Purpose

Lets you add channels to and remove channels from the active channels found when using the AUTO SEARCH option. In this way you can customize the channels that are accessed through CHANNEL (CH) Up/Down.

FAV. CHANNELS is an optional feature. You do not have to activate this feature in order to use your TV.

NOTE: AUX channel cannot be removed.

Before Using FAV. CHANNELS

Use the AUTO SEARCH feature, if not previously used when you first installed the TV.

To Add a Channel to Scan Sequence

1. FAV. CHANNELS display should be shown on the TV if you followed the "Basic Menu Operation" given in the "On-Screen Menus" section.

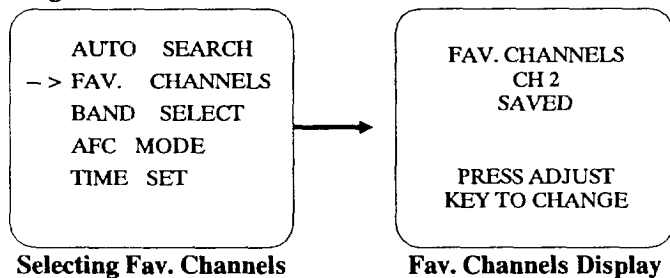

2. Using CHANNEL (CH) Up/Down go to the nearest channel ABOVE the channel you wish to add.
3. Press SELECT to go down to the channel you wish to add.
4. Add channel by pressing ADJUST (ADJ) Left/Right until the display shows SAVED.
5. Press ENTER (ENT) to return to normal TV viewing.

To Remove a Channel from Scan Sequence

1. FAV. CHANNELS display should be shown on the TV if you followed the "Basic Menu Operation" given in the "On-Screen Menus" section.
2. Using CHANNEL (CH) Up/Down go to the channel you wish to remove.
3. Remove channel by pressing ADJUST (ADJ) Left/Right until the display shows SKIPPED.
4. Press ENTER (ENT) to return to normal TV viewing.

When Some Channels Can Not Be Tuned

If you have some difficulty tuning some channels, you may have to manually set the BAND SELECT option. If you have the correct band, but are still having difficulty finding a channel you know to be active, set the AFC MODE to SEARCH.

BAND SELECT

Purpose

Allows for setting the TV tuner to match your antenna or cable-TV system.

If you are having difficulty tuning channels, the BAND SELECT may have to be set manually to match your viewing needs.

Before Using BAND SELECT

Connect and turn ON all external equipment, such as cable-TV decoder, VCR, etc. Before using BAND SELECT, use AUTO SEARCH if not previously used.

NOTE: BAND SELECT is not displayed while AUX channel is being used.

To Use BAND SELECT

1. BAND SELECT display should be shown on the TV if you followed the "Basic Menu Operation" given in the "On-Screen Menus" section.
2. Press ADJUST (ADJ) Left/Right to select the desired tuning band, as follows:

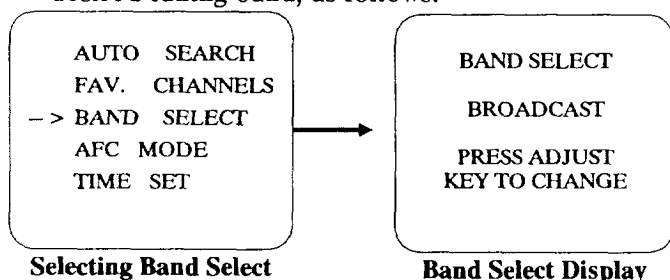

- BROADCAST is used for standard over-the-air broadcasts.
- Cable – CATV is used for most standard cable-TV (CATV) systems.
- Cable – HRC is used for cable-TV systems that use HRC (Harmonically Related Carrier).
- Cable – ICC is used for cable-TV systems using ICC (Incremental Coherent Carrier).

Available Channels per Band

The channels that are available in the broadcast and cable tuning bands are shown below:

BROADCAST Band

VHF 2 to 13 UHF 14 to 69*

* Channels above 69 are not selectable.

CATV, HRC and ICC Bands

00, 0, 1 to 120**

** Channels above 120 are not selectable.

When Some Channels Are Not Clear

If some channels are not clear, change the AFC MODE. You may have to try different BAND SELECT and AFC MODE settings until you get a clear picture, channel-to-channel. Refer to the AFC MODE option for details.

SETUP MENU

AFC MODE

Purpose

Lets your TV compensate for variations in broadcast and cable-TV frequencies.

If you are having difficulty tuning channels, the AFC MODE may have to be set manually to match your viewing needs.

Before Using AFC Mode

Connect and turn ON all external equipment, such as cable-TV decoder, VCR, etc.

NOTE: AFC MODE is not displayed while AUX channel is being used.

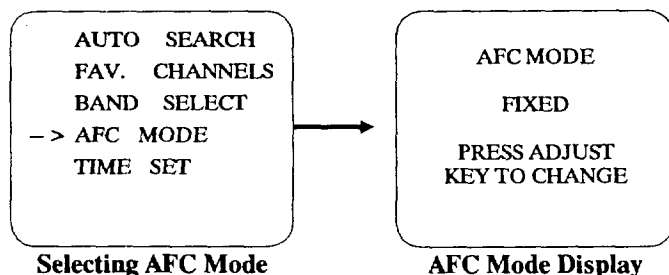

To Use AFC MODE

1. AFC MODE display should be shown on the TV if you followed the "Basic Menu Operation" given in the "On-Screen Menus" section.
2. Press ADJUST (ADJ) Left/Right to select the desired mode of operation, as follows:
 - FIXED is used to receive "over-the-air" TV stations, and with many cable TV systems.
 - SEARCH is used only when the TV must search to find the frequency being received, such as when used with certain VCRs and video game modulators.

When Some Channels Are Not Clear

If some channels are not clear, change the BAND SELECT. You may have to try different AFC MODE and BAND SELECT settings until you get a consistently clear picture, channel-to-channel. Refer to the BAND SELECT option for details.

TIME SET

Purpose

Sets the clock in the TV to the correct time.

After the time has been set, the current time will appear on the Channel/Time display whenever the TV is turned on, the channel is changed, or ENTER (ENT) is pressed.

Power Failure Note: The time will have to be reset if power to the TV is interrupted.

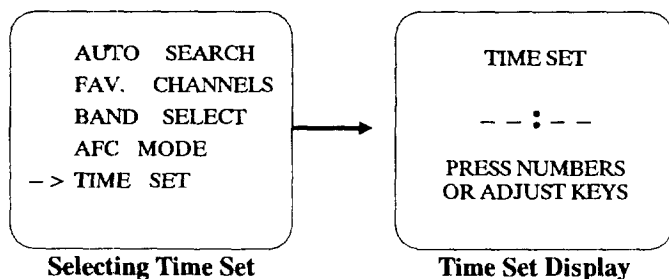

To Use TIME SET from Remote Control

1. TIME SET display should be shown on the TV if you followed the "Basic Menu Operation" given in the "On-Screen Menus" section.
2. Use the numbered buttons on the remote control to enter the current time. Press ENTER (ENT) to start the clock.

For example, to set the clock to 6:30, press 6, then 3, then 0; and then press ENTER (ENT). If you enter an invalid time, such as 14:35 or 2:80, the time will disappear and you can enter another time.

To Use TIME SET from Control Panel

1. TIME SET display should be shown on the TV if you followed the "Basic Menu Operation" given in the "On-Screen Menus" section.
2. Use ADJUST (ADJ) Left/Right to set the time, and then press ENTER (ENT) to start the clock.

VIDEO MENU

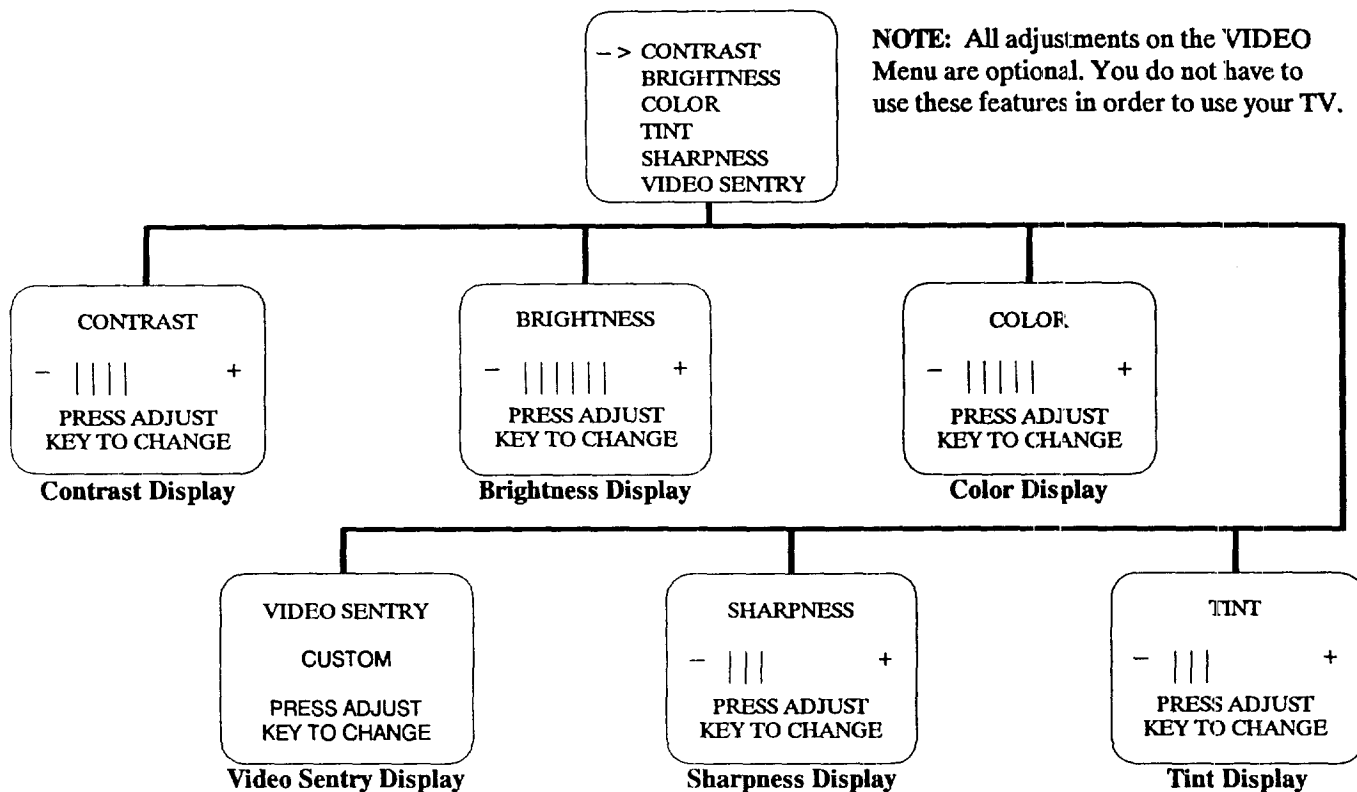

CONTRAST

Adjusts the overall contrast and color level of the picture.

If the light areas in the picture are overly bright and some of the highlight details are missing, press ADJUST (ADJ) Left until the highlights are restored.

If the picture is grayish and lacks contrast and sparkle, press ADJUST (ADJ) Right until you reach the CONTRAST level you prefer.

BRIGHTNESS

Adjusts the brightness level of black areas in the picture.

If the black areas are too light, press ADJUST (ADJ) Left until you reach the BRIGHTNESS level you prefer.

If the black areas in the picture are too dark and show little detail, press ADJUST (ADJ) Right until you reach the BRIGHTNESS level you prefer.

COLOR

Adjusts the intensity of the colors in the picture.

If all the colors seem too vivid or intense, press ADJUST (ADJ) Left to decrease the COLOR intensity.

If all the colors seem faded or washed out, press ADJUST (ADJ) Right to increase the COLOR intensity.

TINT

Adjusts the color of the flesh tones.

If the flesh tones are too red or purple, press ADJUST (ADJ) Left until you reach the desired flesh tones.

If the flesh tones are green or have a greenish TINT, press ADJUST (ADJ) Right until you reach the desired flesh tones.

SHARPNESS

Adjusts the clarity for the clearest picture.

If the picture is too "grainy" and vertical edges show multiple lines on the right side, press ADJUST (ADJ) Left to obtain the desired SHARPNESS.

If the picture is too "soft" and vertical edges are fuzzy, press ADJUST (ADJ) Right to increase the SHARPNESS.

VIDEO SENTRY

Lets you decide if you want to use your own CUSTOM video settings, or the factory PRESET video settings.

Press ADJUST (ADJ) Left/Right to obtain the desired setting.

If the factory PRESET setting is selected, any adjustment made to the VIDEO Menu options, automatically changes the VIDEO SENTRY setting to CUSTOM, and saves your current video settings in the CUSTOM mode.

MAINTENANCE AND TROUBLESHOOTING

CARING FOR YOUR TV

Your TV will look better, have a longer life and perform better if you care for it properly.



First check to see that the TV is off. For added safety, unplug the TV from the power outlet.

Picture Glass Cleaning

The picture tube face attracts dust particles and should be cleaned regularly. To clean the face, spray a small amount of glass cleaner on a cleaning cloth and wipe the picture tube glass face until clean. Repeat if necessary.

To delay new dust accumulation, wet a soft cloth in lukewarm water in which a little fabric softener or Ivory dishwashing detergent has been mixed. Wring the cloth almost dry. Wipe the glass face. Make sure no drops of moisture are squeezed onto the glass. Do not wipe the glass dry. Allow the glass to air-dry before you turn the TV on again.

Cabinet Care

Non-Wood Cabinet or Cabinet Components.

Moisten a soft cloth with a mild soap solution or Ivory dishwashing detergent. Wipe the surface with a damp cloth. Then rinse the cloth in clean water and wipe the surface again. Allow the TV to air-dry before turning it on.

Wood Cabinets or Cabinet Components.

Use any good furniture cleaner and polish. Regular care will help preserve the finish.

EXTENDED ABSENCE

Before an extended absence (such as a vacation) you may want to unplug the power cord from the electrical wall outlet. This will protect the TV from possible damage from lightning or power line surges. If you have an outdoor antenna, you may also want to disconnect the antenna lead-in wires on the back of the TV.

NOTE: If you unplug your TV, you will have to reset the clock to the current time.

TV PICTURE INTERFERENCE

Your TV picture may be affected by interference caused by one or a number of factors. These include:

Nearby Automobile Ignition, Electrical Appliances, etc. Which causes a speckled, streaked picture. This is most noticeable in weak signal areas.

Snow in Picture Caused by insufficient signal. Usually caused by the TV being located too far from the TV station or by an improper antenna installation.

Ghosts or Reflections Caused by signals being reflected from surrounding buildings, water tanks, or other high structures.

Radio Signal Police, amateur or CB radio transmitters may cause interference.

These interference problems can often be corrected through the use of a better antenna, signal amplifiers, or various filter devices. See your TV dealer for additional information, and available TV accessories.

MAINTENANCE AND TROUBLESHOOTING

BEFORE CALLING FOR SERVICE

Check these items and see if you can correct the trouble by changing the adjustment of a control or the setting of a switch.

By making these simple checks before calling for service, you may save time and money.

Problem	Try This
Picture OK. Poor sound.	Re-orient antenna. Check for local interference. Try another channel – possible station trouble. Check AFC MODE and BAND SELECT Menu options.
Sound OK. Poor picture.	Re-orient antenna. Adjust VIDEO Menu options with VIDEO SENTRY in CUSTOM mode. Try another channel – Possible station trouble.
No picture or sound.	Is TV on? Power in wall outlet? TV plugged in? Antenna hooked up? Cable hooked up? Check with your cable company. Check auxiliary audio/video equipment. Check channel selection. Check BAND SELECT and AFC MODE Menu options. Check remote control, if provided.
Picture blurred, ghost in picture, or distorted.	Check antenna or cable hook up for broken wires? Possible station trouble – try another channel. Check for local interference.
No color, or poor color.	Check antenna or cable hook up. Adjust VIDEO Menu options with VIDEO SENTRY in the CUSTOM mode. Is it a color program?
No sound.	Check VOL (VOLUME) setting. Check MUTE button operation on remote control, if provided.
Cannot select certain channels.	Channels may be skipped in FAV. (Favorite) CHANNELS Menu option. Check AFC MODE Menu option.
Remote control does not work.	Are batteries okay? Is TV turned ON? Is TV plugged in?

Always request that your technician use only genuine Zenith exact replacement parts for continued Quality and Safety performance. Keep your Zenith **ALL** Zenith.

NOTE: If your TV fails to respond to the VIDEO SENTRY selection, or to any other menu selection, you must reset the TV. Simply disconnect it from AC power by unplugging the AC power cord from the power outlet. Wait a few minutes, then plug the TV back into the power outlet. You will have to reset the clock to the current time.

YOUR ZENITH WARRANTY

Consumer Protection Plan for Zenith TV

Welcome into the Zenith family! We believe that you will be pleased with your new Zenith Color TV. Please read this Consumer Protection Plan carefully. It is a "LIMITED WARRANTY" as defined under Federal Law. This warranty gives you specific legal rights, and you may also have other rights that vary from state to state within the U.S.A.

Zenith's Responsibility

Service Labor — During a period of 90 days from effective warranty date, Zenith will pay for service labor by a U.S. or Canadian distributor-approved Zenith service center when needed as a result of manufacturing defects.

Parts — New or remanufactured replacements for factory-defective parts will be supplied by a U.S. or Canadian distributor-approved service center for one year from effective warranty date (color picture tube — two years). Such replacement parts are warranted for the remaining portion of the original warranty period.

Home Service — Warranty service for 19" diagonal (U.S.A.) or larger screen size models is provided in the home.

Not Covered — This warranty covers manufacturing defects and does not cover installation, adjustment of customer controls in the home, installation or repair of home antenna systems, cable converters or cable company-supplied equipment; it also does not cover damage due to misuse, abuse, negligence, acts of God or other causes beyond the control of Zenith. Any alteration of the product after manufacture voids this warranty in its entirety.

Owner's Responsibility

Effective Warranty Date — Warranty begins on the date of original consumer installation. For your convenience, keep the dealers dated bill of sale or delivery ticket as evidence of the purchase date.

Operating Guide — Read your Operating Guide carefully so that you will understand the operation of your set and how to adjust the customer controls.

Carry-In Service — Models under 19" diagonal (U.S.A.) screen size must be taken to a distributor-approved Zenith service center for warranty service and must be picked up by the owner.

Antenna — Reception problems caused by inadequate home antennas or faulty antenna connections are the owner's responsibility.

Important: Product Registration — Please fill out and mail your Product Registration Card. It is imperative that Zenith know how to reach you promptly if we should discover a safety problem that could affect you.

Warranty Service — For warranty service information, contact your Zenith dealer preferably, or any distributor-approved Zenith service center. Parts and service labor that are Zenith's responsibility (see above) will be provided without charge. Other service is at the owner's expense. If you have any problem in obtaining satisfactory warranty service, write:

Zenith Electronics Corporation
Customer Service Department
1900 N. Austin Avenue
Chicago, Illinois 60639-5079
Telephone: (312) 745-5152
Mon-Fri, 8:00 a.m. - 4:30 p.m. Central Time

NOTE: Before you ask for Warranty service, check the Operating Guide section entitled, "MAINTENANCE AND TROUBLESHOOTING." It may be possible to avoid a service call.

ZENITH ELECTRONICS CORPORATION
1000 MILWAUKEE AVENUE
GLENVIEW, ILLINOIS 60025

Part No. 206-2597
Printed in U.S.A.
EP-EDCBA