

Operating Guide & Warranty

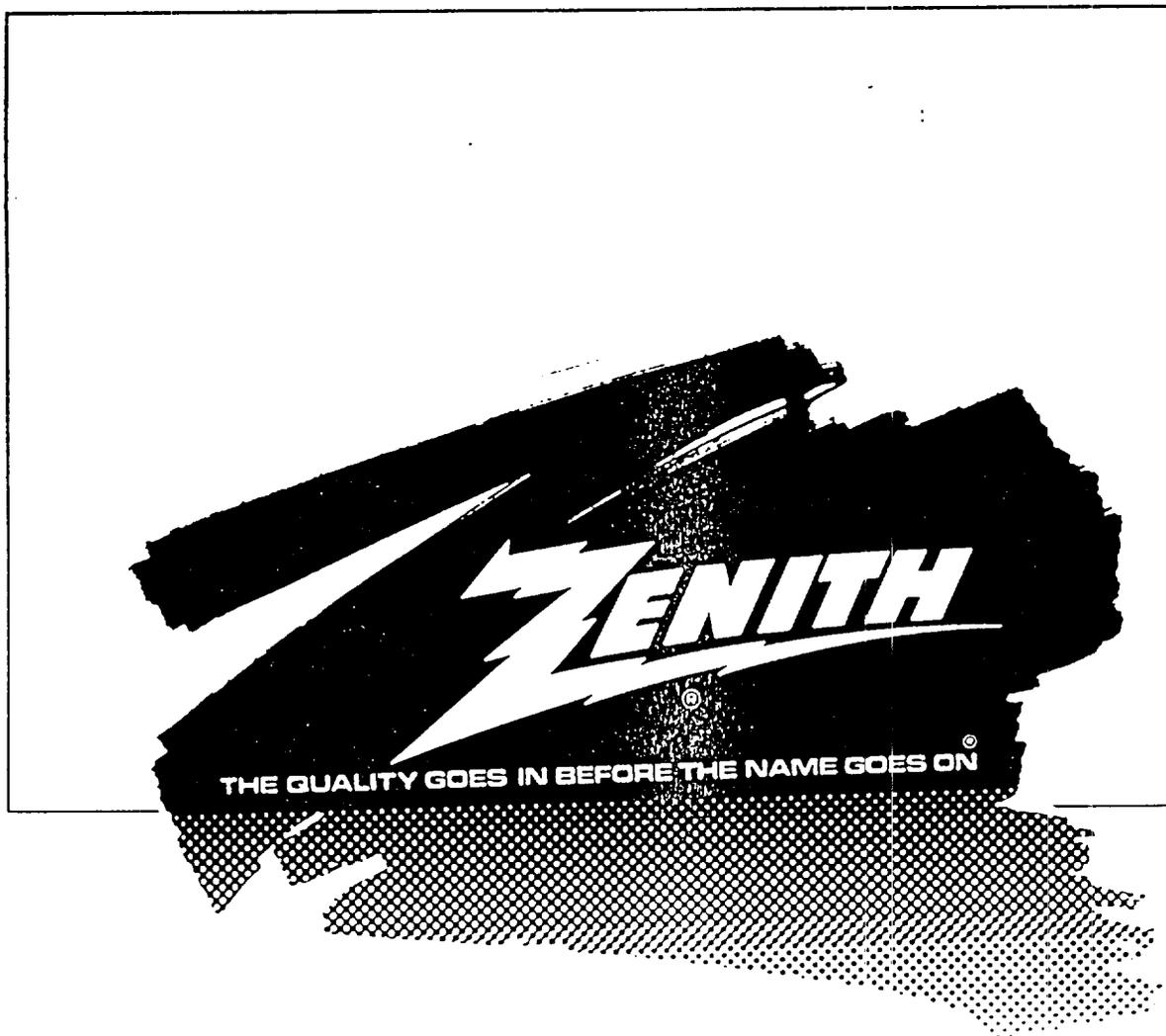

19" Color TV/VCR Combination

SLV1940S

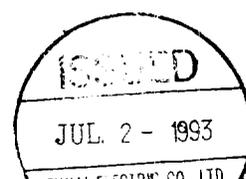

WARNING:
TO REDUCE THE RISK OF FIRE OR ELECTRIC SHOCK, DO NOT EXPOSE THIS APPLIANCE TO RAIN OR MOISTURE.

	CAUTION RISK OF ELECTRIC SHOCK DO NOT OPEN	
<p>CAUTION: TO REDUCE THE RISK OF ELECTRIC SHOCK, DO NOT REMOVE COVER (OR BACK) NO USER SERVICEABLE PARTS INSIDE. REFER SERVICING TO QUALIFIED SERVICE PERSONNEL.</p>		

	<p>THIS SYMBOL INDICATES THAT DANGEROUS VOLTAGE CONSTITUTING A RISK OF ELECTRIC SHOCK IS PRESENT WITHIN THIS UNIT.</p>
	<p>THIS SYMBOL INDICATES THAT THERE ARE IMPORTANT OPERATING AND MAINTENANCE INSTRUCTIONS IN THE LITERATURE ACCOMPANYING THE APPLIANCE.</p>

The important note is located on the rear of the cabinet.

IMPORTANT SAFEGUARDS

1. Read instructions-All the safety and operating instructions should be read before the appliance is operated.
2. Retain Instructions-The safety and operating instructions should be retained for future reference.
3. Heed Warnings-All warnings on the appliance and in the operating instructions should be adhered to.
4. Follow Instructions-All operating and use instructions should be followed.
5. Cleaning-Unplug TV from the wall outlet before cleaning. Do not use liquid cleaners or aerosol cleaners. Use a damp cloth for cleaning.
EXCEPTION : A product that is meant for uninterrupted service and that for some specific reason, such as the possibility of the loss of an authorization code for a CATV converter, is not intended to be unplugged by the user for cleaning or any other purpose, may exclude the reference to unplugging the appliance in the cleaning description otherwise required in item 5.
6. Attachments-Do not use attachments not recommended by the TV manufacturer as they may cause hazards.
7. Water and Moisture-Do not use this TV near water-for example, near a bath tub, wash bowl, kitchen sink, or laundry tub, in a wet basement, or near a swimming pool, and the like.
8. Accessories-Do not place this TV on an unstable cart, stand, tripod, bracket, or table. The TV may fall, causing serious injury to someone, and serious damage to the appliance. Use only with a cart, stand, tripod, bracket, or table recommended by the manufacturer, or sold with the TV. Any mounting of the appliance should follow the manufacturer's instructions and should use a mounting accessory recommended by the manufacturer. An appliance and cart combination should be moved with care. Quick stops, excessive force, and uneven surfaces may cause the appliance and cart combination to overturn.
9. Ventilation-Slots and openings in the cabinet and the back or bottom are provided for ventilation and to ensure reliable operation of the TV and to protect it from overheating, these openings must not be blocked or covered. The openings should never be blocked by placing the TV on a bed, sofa, rug, or other similar surface. This TV should never be placed near or over a radiator or heat register. This TV should not be placed in a built-in installation such as a bookcase or rack unless proper ventilation is provided or the manufacturer's instructions have been adhered to .
10. Power Sources-This TV should be operated only from the type of power source indicated on the marking label. If you are not sure of the type of power supply to your home, consult your appliance dealer or local power company. For TVs intended to operate from battery power, or other sources, refer to the operating instructions.
11. Grounding or Polarization-This TV is equipped with a polarized alternating-current line plug(a plug having one blade wider than the other). This plug will fit into the power outlet only one way. This is a safety feature. If you are unable to insert the plug fully into the outlet, try reversing the plug. If the plug should still fail to fit, contact you electrician to replace your obsolete outlet. Do not defeat the safety purpose of the polarized plug.
12. Power-Cord Protection-Power-supply cords should be routed so that they are not likely to be walked on or pinched by items placed upon or against them, paying particular attention to cords at plugs, convenience receptacles, and the point where they exit from the appliance.
13. Outdoor Antenna grounding-If an outside antenna or cable system is connected to the TV, be sure the antenna or cable system is grounded so as to provide some protection against voltage surges and built-up static charges. Section 810 of the National Electrical Code, ANSI/NFPA No. 70-

PORTABLE CART WARNING



S3126A

FIGURE A
EXAMPLE OF ANTENNA GROUNDING AS PER
NATIONAL ELECTRICAL CODE

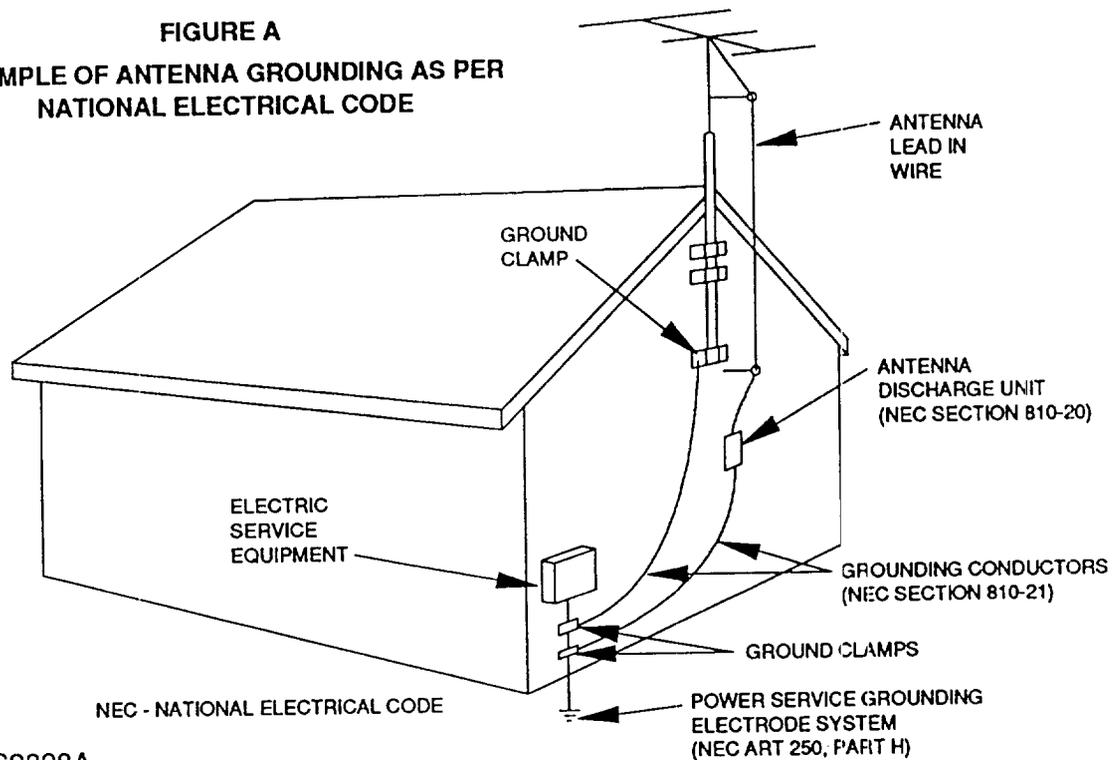

S2898A

1984, provides information with respect to proper grounding of the mast and supporting structure, grounding of the lead-in wire to an antenna discharge unit, size of grounding conductors, location of antenna-discharge unit, connection to grounding electrodes, and requirements for the grounding electrode. (Fig. A)

14. **Lightning**-For added protection for this TV receiver during a lightning storm, or when it is left unattended and unused for long periods of time, unplug it from the wall outlet and disconnect the antenna or cable system. This will prevent damage to the TV due to lightning and power-line surges.
15. **Power Lines**-An outside antenna system should not be located in the vicinity of overhead power lines or other electric light or power circuits, or where it can fall into such power lines or circuits. When installing an outside antenna system, extreme care should be taken to keep from touching such power lines or circuits as contact with them might be fatal.
16. **Overloading**-Do not overload wall outlets and extension cords as this can result in a risk of fire or electric shock.
17. **Object and Liquid Entry**-Never push objects of any kind into this TV through openings as they may touch dangerous voltage points or shortout parts that could result in a fire or electric shock. Never spill liquid of any kind on the TV.
18. **Servicing**-Do not attempt to service this TV yourself as opening or removing covers may expose you to dangerous voltage or other hazards. Refer all servicing to qualified service personnel.
19. **Damage Requiring Service**-Unplug this TV from the wall outlet and refer servicing to qualified service personnel under the following conditions:
 - a. When the power-supply cord or plug is damaged or frayed.
 - b. If liquid has been spilled, or objects have fallen into the TV.
 - c. If the TV has been exposed to rain or water.
 - d. If the TV does not operate normally by following the operating instructions. Adjust only those controls that are covered by the operating instructions as improper adjustment of other controls may result in damage and will often require extensive work by a qualified technician to restore the TV to its normal operation.
 - e. If the TV has been dropped or the cabinet has been damaged.
 - f. When the TV exhibits a distinct change in performance-this indicates a need for service.
20. **Replacement Parts**-When replacement parts are required, be sure the service technician has used replacement parts specified by the manufacturer that have the same characteristics as the original part. Unauthorized substitutions may result in fire, electric shock, injury to persons or other hazards.
21. **Safety Check**-Upon completion of any service or repairs to this TV, ask the service technician to perform routine safety checks to determine that this TV is in proper operating condition.

TABLE OF CONTENTS

IMPORTANT SAFEGUARDS	2	OPERATION	19
PRECAUTIONS	5	T.V. OPERATION	19
LOCATION	5	VIEWING AND RECORDING THE SAME	
AVOID THE HAZARDS OF		PROGRAM	20
ELECTRICAL SHOCK AND FIRE	5	AUTOMATIC TIMER RECORDING	22
WARNING	5	QUICK SET PROGRAM	25
SUPPLIED ACCESSORIES	5	CHECKING THE COUNTER, CLOCK AND	
FEATURES	6	CHANNEL NUMBER	27
OPERATING CONTROLS AND FUNCTIONS	7	OTR (ONE TOUCH RECORDING)	28
REMOTE CONTROL OPERATION	9	SETTING THE SLEEP TIMER	29
HOW TO USE REMOTE CONTROL	9	PLAYBACK	29
INSTALLING THE BATTERIES	10	RENTAL PLAY	29
ANTENNA CONNECTIONS	11	AUTO REPEAT PLAYBACK	30
VHF/UHF COMBINED ANTENNA	11	CLOSED CAPTION SYSTEM	30
UHF/VHF SEPARATE ANTENNAS	11	TROUBLESHOOTING GUIDE	33
CABLE WITHOUT		MAINTENANCE	34
CONVERTER/DESCRAMBLER BOX	12	CABINET CLEANING	34
EXTERNAL INPUT MODE	12	HEAD CLEANING	34
CABLE WITH		SERVICING	34
CONVERTER/DESCRAMBLER BOX	12	SPECIFICATIONS	35
PREPARATION FOR USE	13	GENERAL SPECIFICATIONS	35
SELECTING LANGUAGE (ENGLISH OR		ELECTRICAL SPECIFICATIONS	35
SPANISH)	13	OTHER SPECIFICATIONS	35
SETTING THE CLOCK FOR CORRECT TIME	14		
VIDEO CASSETTE	16		
CHANNEL PRESETTING	17		
TO DELETE OR ADD PRESET CHANNEL	18		

PRECAUTIONS

LOCATION

For safe operation and satisfactory performance of your unit, keep the following in mind when selecting a place for its installation:

- ◆ Shield it from direct sunlight and keep it away from sources of intense heat.
- ◆ Avoid dusty or humid places.
- ◆ Avoid places with insufficient ventilation for proper heat dissipation. Do not block the ventilation holes at the top and bottom of the unit. Do not place the unit on a carpet because this will block the ventilation holes.
- ◆ Install unit in a horizontal position.
- ◆ Avoid locations subject to strong vibration.
- ◆ Do not place the unit near strong magnetic fields.
- ◆ Do not move the unit from a cold to a hot place or vice versa.

AVOID THE HAZARDS OF ELECTRICAL SHOCK AND FIRE

- ◆ Do not handle the power cord with wet hands.
- ◆ Do not pull out the power cord when disconnecting it from an AC wall outlet. Grasp it by the plug.
- ◆ If, by accident, water is spilled on your unit, unplug the power cord immediately and take the unit to an authorized video service center for servicing.
- ◆ Do not put your fingers or objects into the VCR cassette holder.
- ◆ Do not place anything directly on top of the unit.

WARNING

Moisture condensation may occur inside the unit when it is moved from a cold place to a warm place, or after heating a cold room or under conditions of high humidity. If playing a tape with a TV/VCR which has moisture, it may damage the tape and TV/VCR. Therefore when the condensation occurs inside the unit turn the POWER button on and allow at least 2 hours for the unit to dry out.

IMPORTANT COPYRIGHT INFORMATION

Unauthorized recording or use of broadcast television programming, video tape, film or other copyrighted material may violate applicable copyright laws. We assume no responsibility for the unauthorized duplication, use or other acts which infringe upon the rights of copyright owners.

SUPPLIED ACCESSORIES

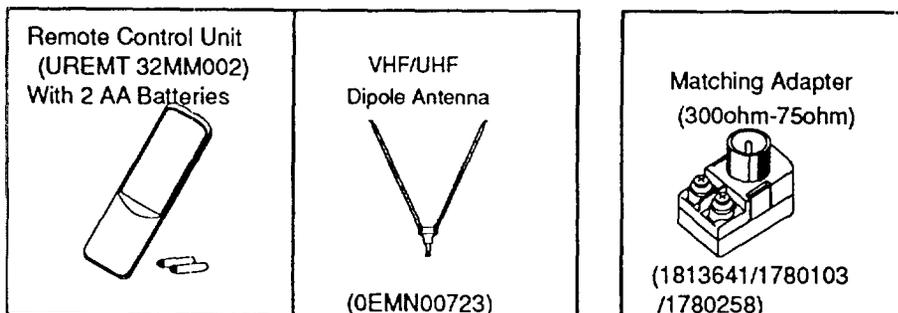

FEATURES

- ◆ **4 Rotary Head Record /Playback System**– 4 rotary heads to ensure excellent picture quality and special effects playback.
- ◆ **Auto Power On and Off system**– Automatically turns the TV/VCR on as you insert the cassette, and turns off after auto-rewind, ejects when reaches beginning of the tape.
- ◆ **Three Different Record/Playback Speed**– Select the SP mode (Standard play), LP mode (Long play) and SLP mode (Super long play) for up to eight hours of recording/playback with a T-160 tape.
- ◆ **On-Screen-Display**– All major operating and programming functions appear on your TV screen for operating convenience.
- ◆ **On Screen Selectable language for English or Spanish**
- ◆ **Automatic Playback Speed Selection**– Automatically selects the proper playback speed even if you set speed select to different mode.
- ◆ **1 Year, 8 Events Timer (including daily and weekly)**– The built-in timer allows you to record up to 7 programs at different times on different channels up to 1 year in advance. The Quick Set Program feature uses program number 8. Also a daily timer will allow recordings to be made of daily broadcasts and the weekly timer will allow recording to be made once a week up to the end of the tape.
- ◆ **Quick Set Program**– The Quick Set Program allows you to easily record one program within 24 hours.
- ◆ **Picture Search**– You may view the video program at a high speed in either a forward or reverse direction.
- ◆ **Slow Motion**– Allows you to view the video program at a slower than normal playback speed.
- ◆ **STILL**– "Freeze" the picture at any time, for close viewing of a particular scene.
- ◆ **PLL Frequency Synthesizer Tuner with 181 Channel Cable-compatible with Direct station Call**– (A CATV Box may be necessary to view pay CATV channels.)
- ◆ **32 Buttons Infrared Remote control**– Allows you to use most of control from a remote location.
- ◆ **Rental Play Mode**– Improves playback picture quality of worn tapes, especially rental tapes.
- ◆ **Auto Repeat Play back**– Let you set the TV/VCR to automatically repeat a tape when it reaches the end.
- ◆ **CCS (Closed Caption System)**– You may watch dramas, movies and news etc. with captioning the dialogues and the contents of news if you want.

OPERATING CONTROLS AND FUNCTIONS

— FRONT VIEW —

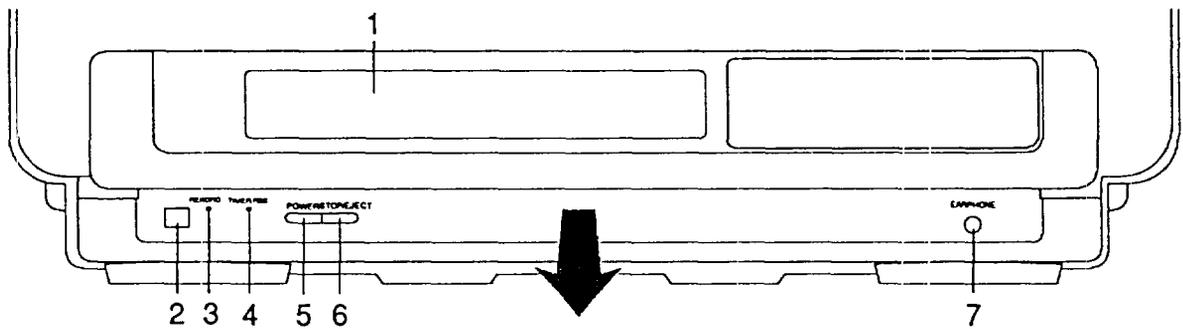

— CONTROL DOOR INSIDE VIEW —

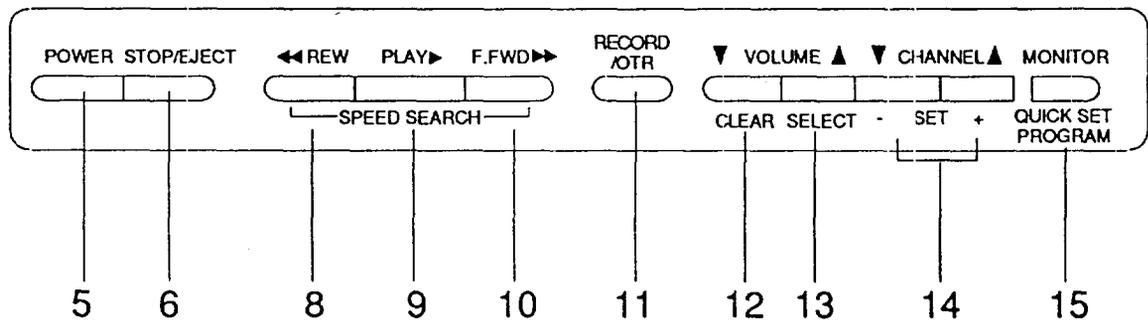

— REAR VIEW —

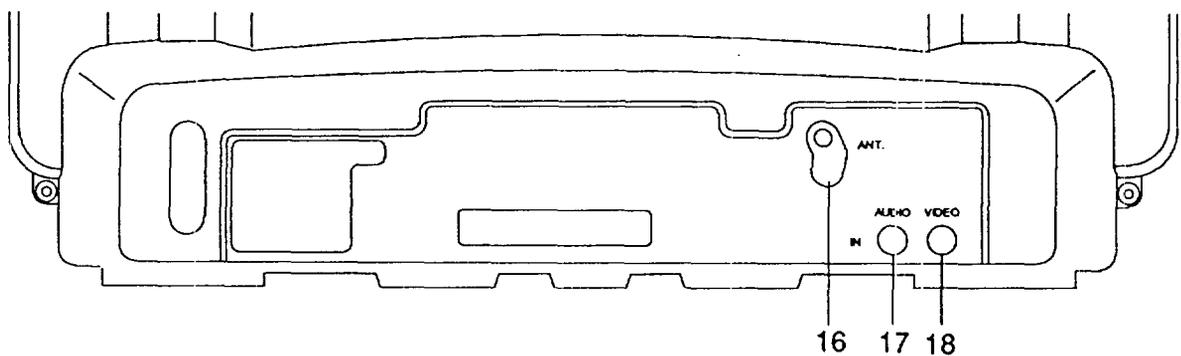

-
- 1 **CASSETTE COMPARTMENT**
 - 2 **Remote Sensor**– Receives the infrared control signals from the handheld remote control unit.
 - 3 **RECORD indicator**– Lights when in the Recording mode.
 - 4 **TIMER REC indicator**– Lights when in the Timer Recording mode.
 - 5 **POWER button**– To turn TV/VCR on and off. Press to activate the automatic recording timer.
 - 6 **STOP/EJECT button**– Press to stop tape motion. Press to remove tape from TV/VCR.
 - 7 **EARPHONE jack**– To connect earphone (not supplied) for personal listening.
 - 8 **REW button**– Press to rewind tape, or to view video in reverse during Play mode at a faster than normal speed. Press PLAY button to return TV/VCR to normal playback speed.
 - 9 **PLAY button**– Press to begin playback of a tape.
 - 10 **F.FWD button**– Press to advance tape, or to view video in forward direction during Play mode at a faster than normal speed. Press PLAY button to return TV/VCR to normal playback speed.
 - 11 **RECORD/OTR button**– Press to begin manual recording. Press to activate One Touch Recording mode.
 - 12 **VOLUME ▼ button**– To decrease the volume level.
CLEAR button– Press to cancel Quick Set Program.
 - 13 **VOLUME ▲ button**– To increase the volume level.
SELECT button– Press to select next step when setting Quick Set Program.
 - 14 **CHANNEL buttons**– Press to select the channel for viewing or recording.
TRACKING buttons– Adjust to minimize video 'noise' (lines or dots on screen) during playback.
SET buttons– Adjust time with "+" or "-" button.
 - 15 **MONITOR button**– Press to turn the TV screen on and off when in the Recording mode.
QUICK SET PROGRAM button– Press to set Quick Set Program.
 - 16 **ANT. terminal**– Connect an antenna or CATV.
 - 17 **AUDIO IN jack**– Connect to audio output jack of your audio equipment or another VCR.
 - 18 **VIDEO IN jack**– Connect to video output jack of your video camera or another VCR.

REMOTE CONTROL OPERATION

You can operate most of functions from the Remote Control (included). The buttons on the Remote Control have the same functions as the corresponding buttons on the unit.

HOW TO USE REMOTE CONTROL

- 1 **POWER button**– To activate the automatic timer recording and turn TV/VCR on and off.
- 2 **NUMBER buttons**– To select desired channels. To select channels 1 to 9, first press the 0 button and then press desired channel button 1 to 9.
+100 button– To select channels which are equal or greater than number 100.
- 3 **STOP button**– To stop tape motion.
- 4 **PLAY button**– To playback the tape.
- 5 **REW button**– To rewind the tape. To view the picture rapidly in reverse, in the play mode. (Rewind Search)
- 6 **F.FWD button**– To move the tape forward rapidly. To view the picture rapidly in forward in the play mode. (Forward Search)
- 7 **REC button**– Press to begin manual recording.
- 8 **F.ADV button**– Press this button during the Pause/Still mode to advance one frame. To release, press PLAY button.
PAUSE/STILL button– To stop the tape temporarily during playback or recording.
- 9 **MENU button**– Press to display main menu on the TV screen. (This function is operative only when the main menu is displayed on TV screen in the Stop mode.)
- 10 **SELECT button**– Press to select setting modes (clock, counter, tape speed, program, CH preset) in the main menu. (This function is operative only when the main menu is displayed on TV screen in the Stop mode.)
Status function– Press to display the counter or the current channel number and current time on the TV screen.
- 11 **ADD/DELETE button**– Press to cancel memorized channel or Timer Program, and to add desired channel. (This function is operative only when the main menu is displayed on TV screen in the Stop mode.) (See page 18)
COUNTER RESET button– To reset counter to 0000.
- 12 **COUNTER MEMORY button**– To set counter memory on and off. (See page 21)
- 13 **SPEED button**– To set desired recording speed. (SP/LP/SLP)
- 14 **MONITOR button**– Press to turn the TV screen on and off when in the Recording mode.
- 15 **MUTE button**– To mute sound. Press again to resume sound.
- 16 **SLOW button**– Press in playback for slow motion.
- 17 **VOLUME buttons**– To adjust desired volume level by pressing either "▲" or "▼" button.
- 18 **CH. buttons**– To select desired channel by pressing either "▲" or "▼" button. They cannot be used during Timer Recording. They may also be used to adjust the picture control. (See page 19)
SET button– Adjust time with "▲" or "▼" button in the Menu mode. (This function is operative only when the main menu is displayed on TV screen in the Stop mode.)
TRACKING buttons– Adjust to minimize video 'noise' (lines or dots on screen) during playback. (See page 32)
- 19 **EJECT button**– Press to remove tape from TV/VCR.
- 20 **SLEEP button**– To activate the sleep function. (See page 29)

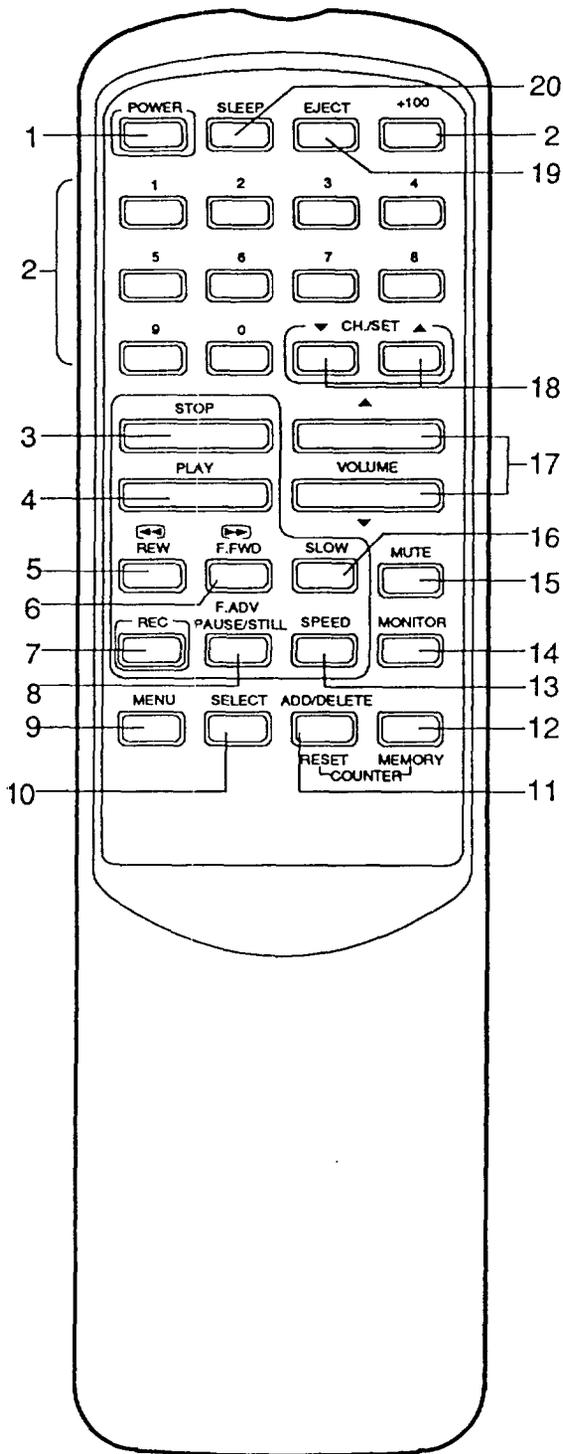

INSTALLING THE BATTERIES

1

Slide the battery compartment cover by pressing the cover on the remote unit in the direction of the arrow.

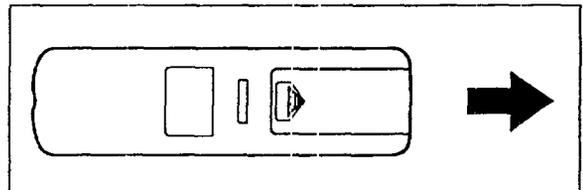

2

Insert 2 "AA" penlight batteries into the battery compartment in the direction as indicated by the polarity (+/-) markings.

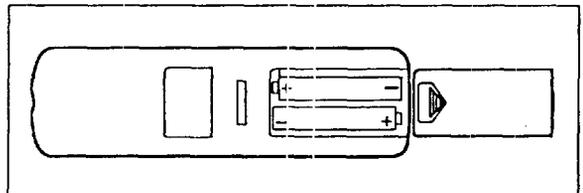

3

Replace the cover.

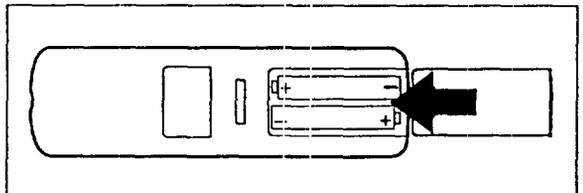

ANTENNA CONNECTIONS

VHF/UHF COMBINED ANTENNA

The UHF/VHF Dipole Antenna (accessory) is detachable. Push the stem of the antenna into the hole which is located on the upper back cabinet of the unit. Connect the flat twin-lead cable from the Dipole antenna to the Matching Adapter (accessory). Plug the Matching Adapter to ANT. terminal of TV/VCR. Connect VHF/UHF Combination Antenna to ANT. terminal of TV/VCR as shown in drawing. For the best reception, extend the Dipole antenna and adjust its length and position. (Avoid handling the top section when making adjustments.)

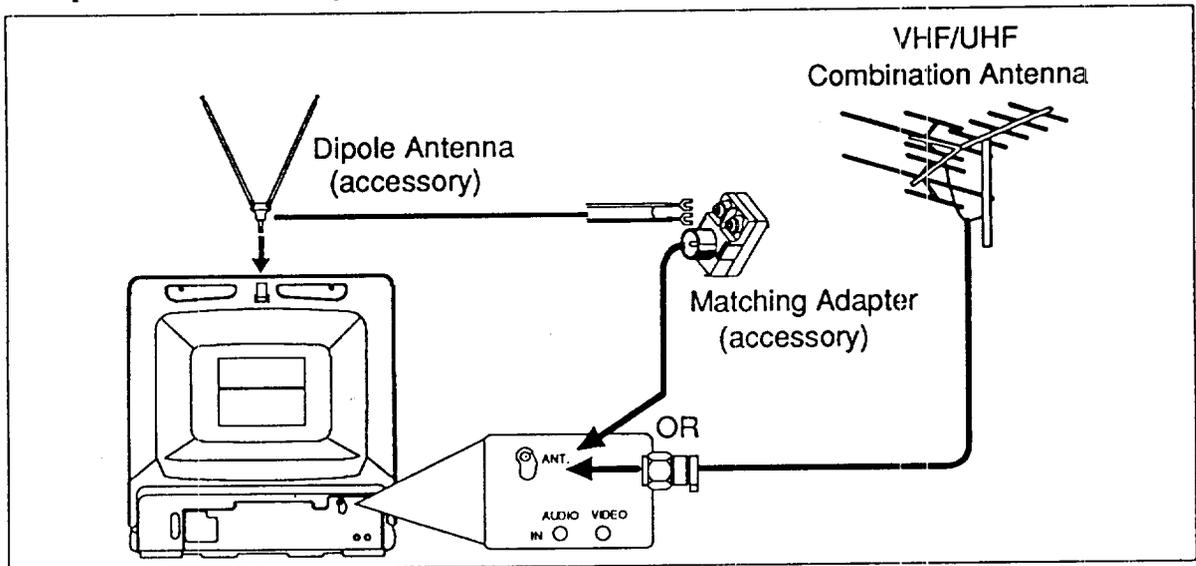

UHF/VHF SEPARATE ANTENNAS

In some areas it will be necessary to use an outdoor antenna.

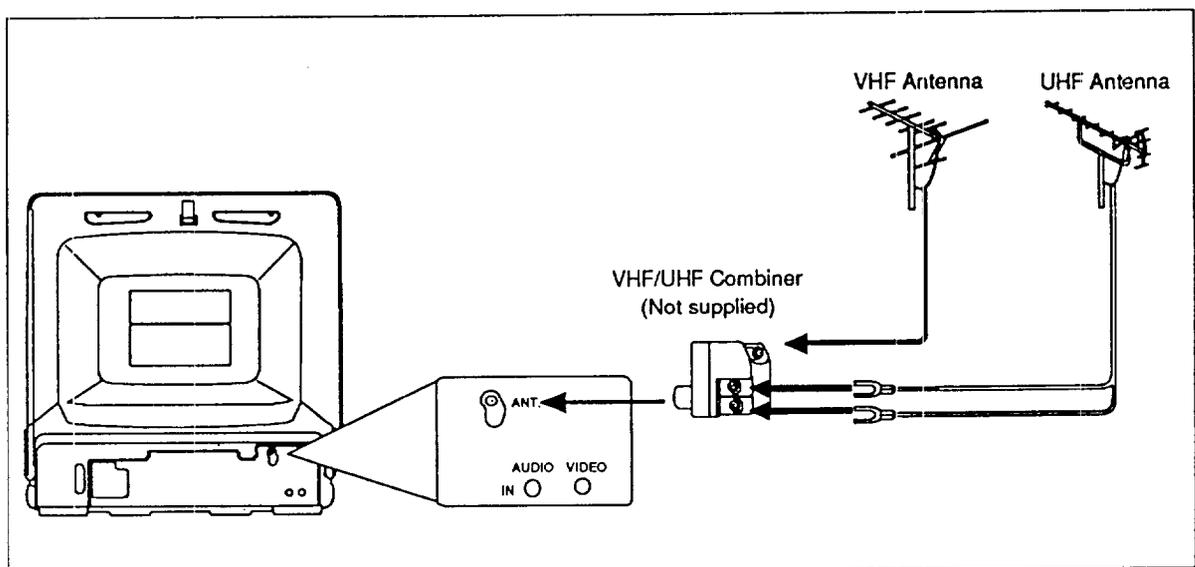

CABLE WITHOUT CONVERTER/DESCRAMBLER BOX

Use this connection if your cable system connects directly to your TV/VCR without a converter box. With this connection you 1) can use your TV/VCR Remote Control to select channels 2) program one or more unscrambled channels for unattended recording.

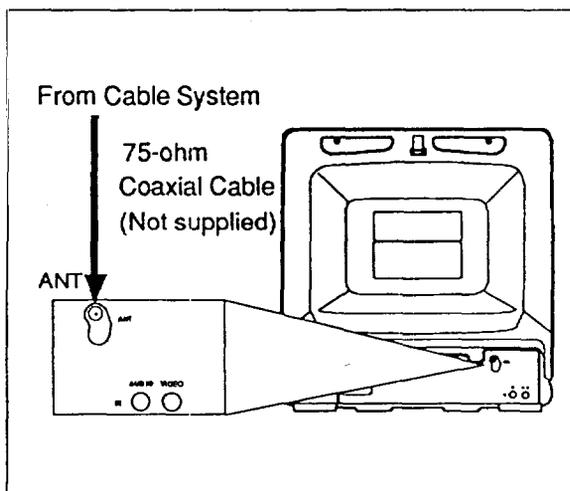

CABLE WITH CONVERTER/DESCRAMBLER BOX

If your cable service supplies you with a converter box you can use the basic connection shown here.

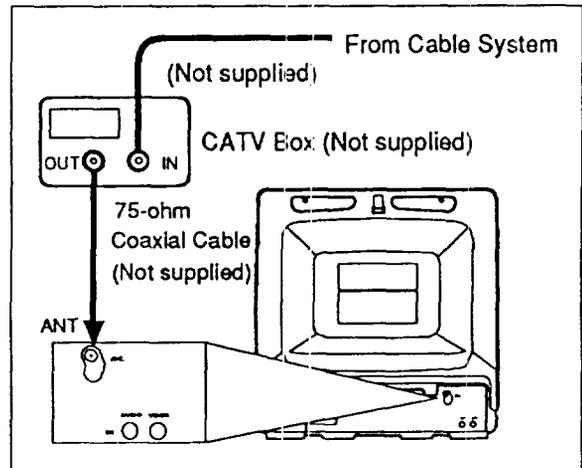

With this connection you can record and view any channel including scrambled channels. However channel selection must be made at the cable company converter box. This means that channels cannot be changed using the TV/VCR Remote Control. Unattended recording is limited to one channel at a time.

EXTERNAL INPUT MODE

When using an external input signal, connect the audio/video cable to the AUDIO IN, VIDEO IN jacks. To use the external input jack, select the AUX position. Press CH. "▲" or "▼" button or enter "00" with number button so that AUX appears on the screen.

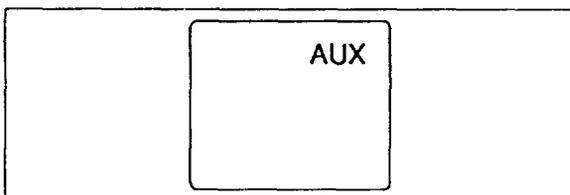

TO RECORD AND VIEW A SCRAMBLED/UNSCRAMBLED CHANNEL

1. Set the TV/VCR channel selector to the output channel of the Cable Converter Box. (Ex. CH3)
2. Select the channel to be recorded or viewed on the Cable Converter Box.

Note to CATV system installer

This reminder is provided to call the CATV system installer's attention to Article 820-40 of the NEC that provides guidelines for proper grounding and, in particular, specifies that the cable ground shall be connected to the grounding system of the building as close to the point of cable entry as practical.

PREPARATION FOR USE

SELECTING LANGUAGE (ENGLISH OR SPANISH)

You may select the display on the TV screen to be either English or Spanish.

1

Plug the TV/VCR power cord into a standard AC outlet. Press POWER button to turn on.

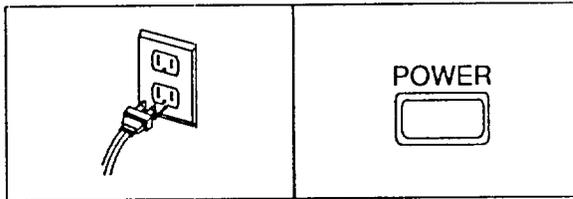

2

Press MENU button on the remote control.

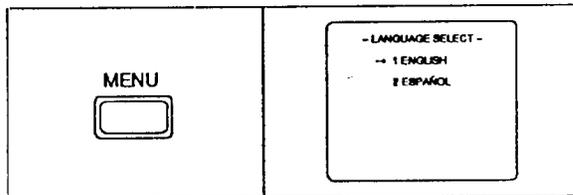

3

Select 1(ENGLISH) or 2(ESPAÑOL=SPANISH) with number button or CH./SET "▲" or "▼" button.

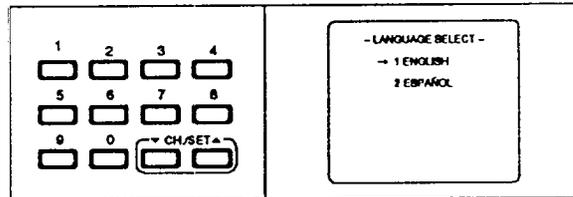

4

Press MENU button to return to normal mode.

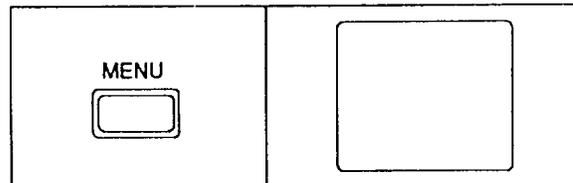

TO CHANGE THE LANGUAGE

If you want change the language of the display, follow steps below.

1

Press MENU button on the remote control.

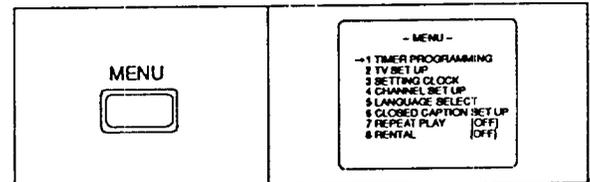

2

Select item 5(LANGUAGE SELECT) with number button or CH./SET "▲" or "▼" button.

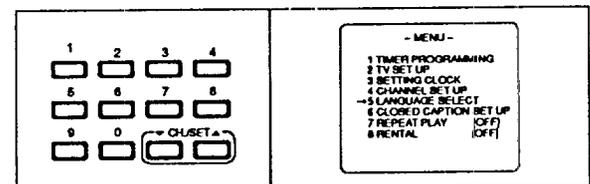

3

Press SELECT button.

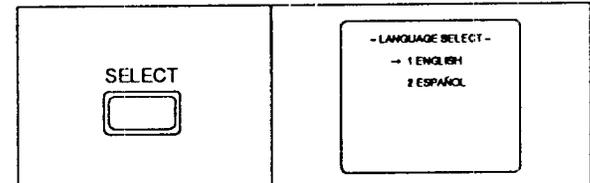

4

Select 1(ENGLISH) or 2(ESPAÑOL=SPANISH) with number button or CH./SET "▲" or "▼" button.

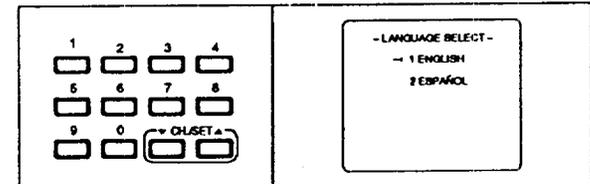

5

Press MENU button to return to normal mode.

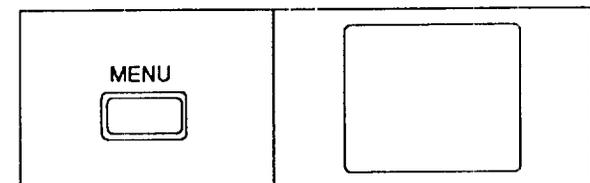

SETTING THE CLOCK FOR CORRECT TIME

Set the clock accurately for proper automatic timer recording.

Note: The instructions refer to the TV's on-screen display indicators. Some of the indications on the TV/VCR's display vary slightly.

In the example below, the clock is to be set to:

DATE March 1st, 1993
SETTING TIME 5:40PM.

◆ You must use the remote control unit for the following steps.

1

Press POWER button to turn on the TV/VCR.

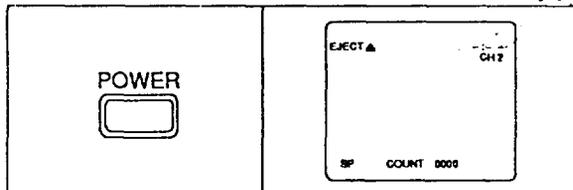

2

Press MENU button.

The main menu display appears on the TV screen.

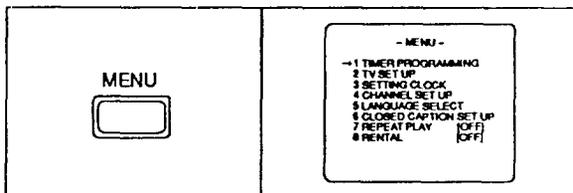

3

◆ Select item 3 (SETTING CLOCK) with number button or the CH./SET "▲" or "▼" button.

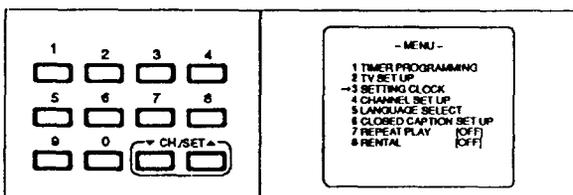

4

Press SELECT button.

"SETTING CLOCK" appears on the TV screen. The MONTH digits flash.

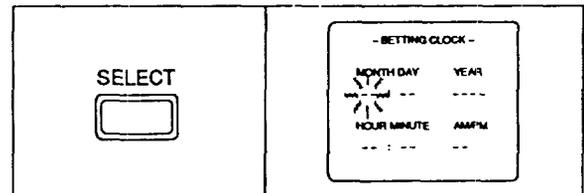

5

Enter the desired month with number button or the CH./SET "▲" or "▼" button. (Example: 03)

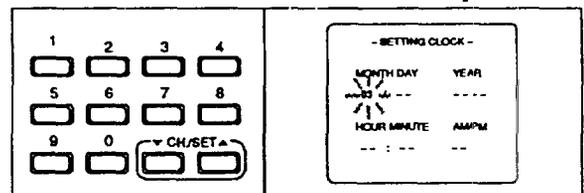

◆ After 1 second the DAY digits flash.

6

Enter the desired day with number button or the CH./SET "▲" or "▼" button. (Example: 01)

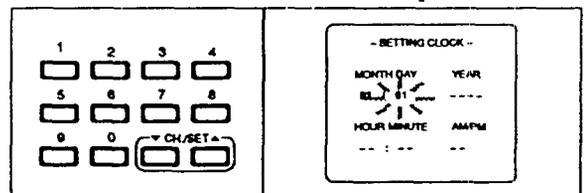

◆ After 1 second the YEAR digits flash.

7

Enter the desired year with number button or the CH./SET "▲" or "▼" button. (Example: 1993)

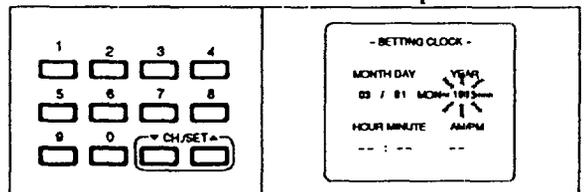

◆ After 1 second the HOUR digits flash.

8

Enter the desired hour with number button or the CH./SET "▲" or "▼" button. (Example: 05)

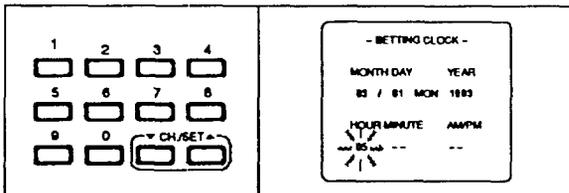

◆ After 1 second the MINUTE digits flash.

9

Enter the desired minute with number button or the CH./SET "▲" or "▼" button. (Example: 40)

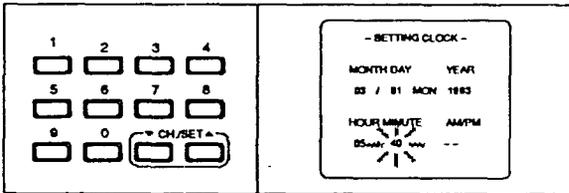

◆ After 1 second the AM/PM digits flash.

10

Enter 1 to select AM or enter 2 to select PM with number button or the CH./SET "▲" or "▼" button. (Example: 2→PM)

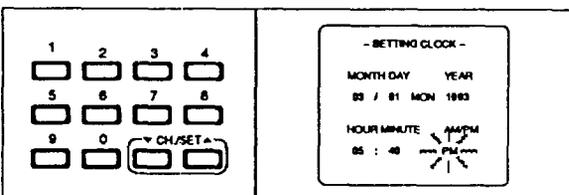
**11**

Press MENU or SELECT button to start the clock. Although seconds are not displayed, they begin counting at 00 when you press MENU or SELECT button. Use this feature to set the clock as accurately as possible.

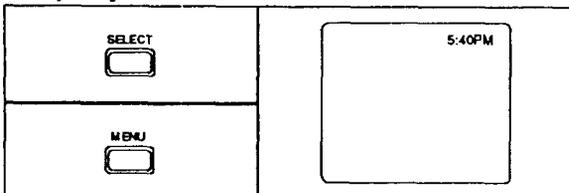

◆ This unit has a built in calendar up to the year 2007.

TO CORRECT CLOCK SETTING

If you want to change the clock,

- 1) Follow step [2] to [4], page 14.
- 2) Select desired digit with SELECT button or ADD/DELETE button.
- 3) Enter correct numbers with number button or CH./SET "▲" or "▼" button.
- 4) Press MENU or SELECT button to original mode.

VIDEO CASSETTE

This TV/VCR will operate with any cassette that has the VHS mark. For best results we recommend the use of high-quality tape.

◆ Do not use poor quality or damaged tape. The table below shows the recording/playback time using T-60, T-120 or T-160 tape in the SP, LP or SLP mode.

MODE	CASSETTE		
	T-60	T-120	T-160
SP Mode	1 hour	2 hours	2-2/3 hours
LP Mode	2 hours	4 hours	5-1/3 hours
SLP Mode	3 hours	6 hours	8 hours

When handling video tapes, take the following precautions

- ◆ Avoid moisture, which can condense on the tape if it is moved from a cold place to a warm place. Playing a tape that has moisture in it will damage the tape and your TV/VCR. Before using a tape with these conditions, wait until the tape has warmed to room temperature and the moisture has evaporated.
- ◆ Avoid extreme heat, high humidity and magnetic fields.
- ◆ Do not tamper with the cassette mechanism.
- ◆ Do not touch the tape with your fingers.

ERASE PREVENTION

You may prevent accidental erasing of a tape by breaking off the tab on the back edge of the cassette. If you decide to record on the tape again, cover the hole with plastic tape.

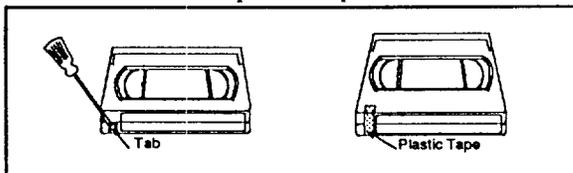

Insert the cassette into the TV/VCR as shown.

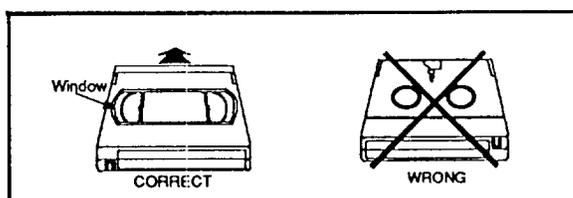

Store the cassette in its case as shown.

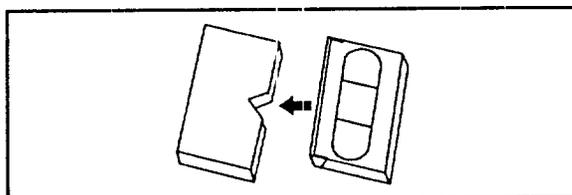

INSERTING A CASSETTE

Insert the cassette in the direction as shown. Push in gently, but continuously, on the center-back of the cassette until it is drawn completely into the TV/VCR.

TV/VCR is automatically turned on when the cassette is properly inserted.

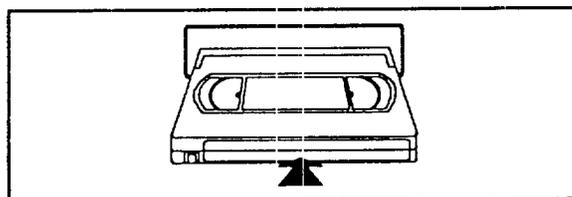

REMOVING A CASSETTE

1

Press EJECT button on the main unit or on the remote control unit.

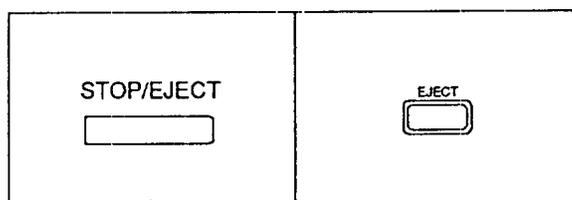

2

When the cassette stops moving, pull the cassette out of the cassette compartment and store it properly.

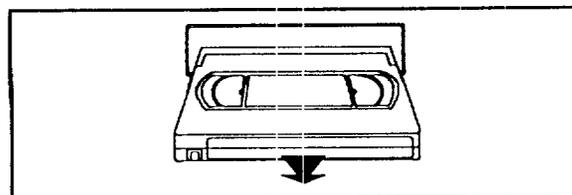

CHANNEL PRESETTING

This TV/VCR is equipped with a frequency synthesizer tuner capable of receiving 181 channels (VHF channels 2 ~ 13, UHF channels 14 ~ 69 and CATV channels 1 ~ 125).

You can program the tuner to scan only the channels you receive in your area.

AUTOMATIC CHANNEL MEMORY

- ◆ You must use the remote control unit for the following steps.

1

Press POWER button to turn on the unit.

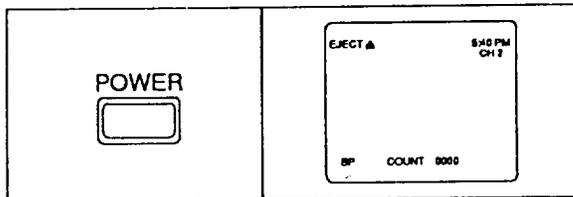

2

Press MENU button. The main menu display appears on the TV screen.

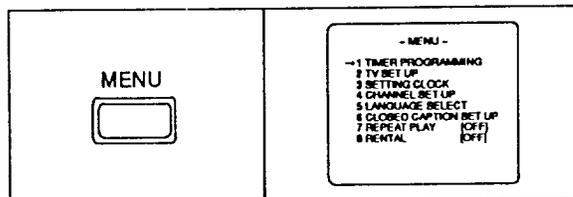

3

Select item 4 (CHANNEL SET UP) with number button or the CH./SET "▲" or "▼" button.

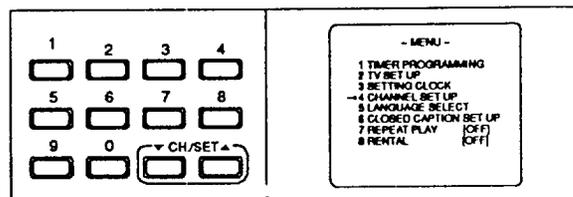

4

Press SELECT button.

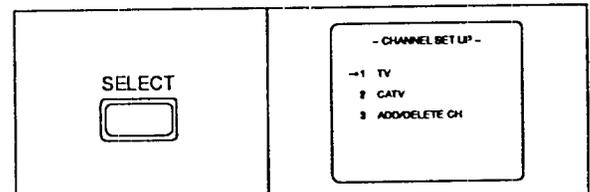

5

Enter 1 to select TV mode or enter 2 to select CATV mode with number button or CH "▲" or "▼" button (Example: TV)

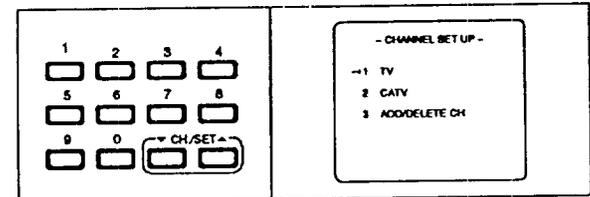

6

Press SELECT button. The tuner scans and memorizes all the active channels in your area. (TV: from CH2 / CATV: from CH1)

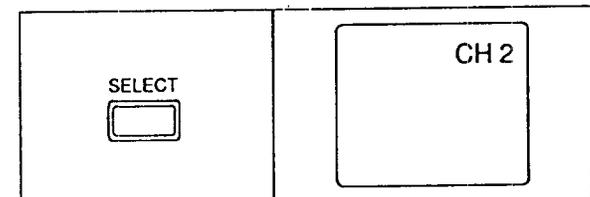

7

After scanning, the tuner stops on the lowest memorized channel. (Example: CH2)

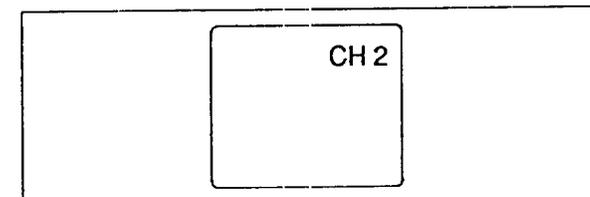

TO DELETE OR ADD PRESET CHANNEL

To add or delete the desired channels. Follow steps [1] to [4] on page 16, then step [5] below.

5

Select item 3 (ADD/DELETE CH) with number button or CH./SET "▲" or "▼" button.

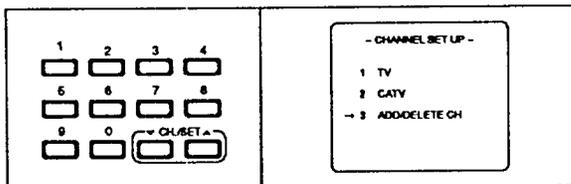

6

Press SELECT button.

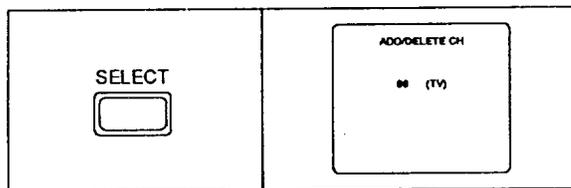

FOLLOW STEPS [7a~8a] OR [7b~8b] TO DELETE OR ADD THE CHANNEL. THEN GO TO SETP [9].

9

Press MENU button. The TV screen returns to TV mode.

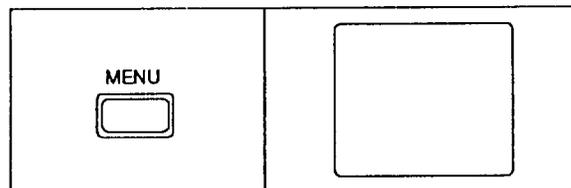

Note: To confirm that channel(s) has been deleted, press CH./SET "▲" or "▼" button.

NOTE:
Added channel is in light blue
Deleted channel is in light red

DELETING PRESET CHANNEL

7a

Enter the desired channel number using the number button or the CH./SET "▲" or "▼" button.

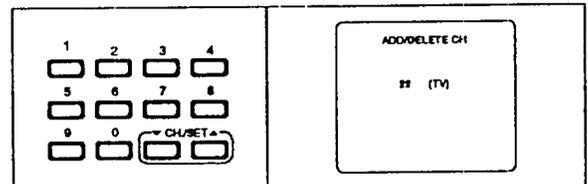

8a

Press ADD/DELETE button. The channel number changes to light red. The channel is deleted.

Notes:

- ◆ To delete another channel, repeat step [7a] to [8a].
- ◆ If you press ADD/DELETE button again, the channel is memorized again.

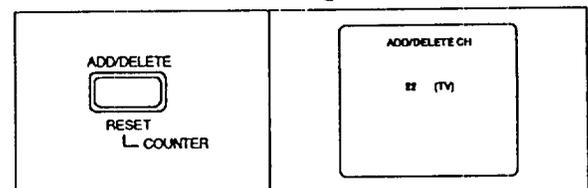

ADDING PRESET CHANNEL

7b

Enter the desired channel number using the number button or the CH./SET "▲" or "▼" button.

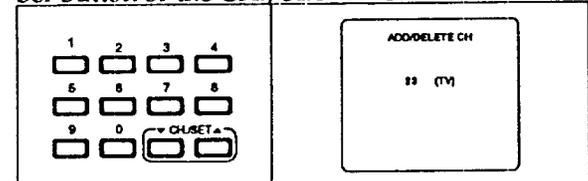

8b

Press ADD/DELETE button. The channel number changed to light blue. The channel is added to the TV/VCR.

Notes:

- ◆ To add another channel, repeat step [7b] to [8b].
- ◆ If you press ADD/DELETE button the again, the channel is deleted again.

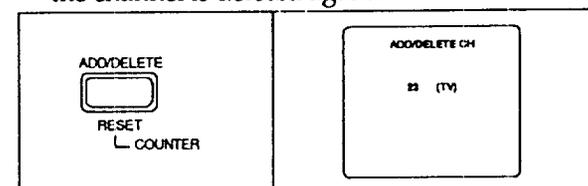

OPERATION

T.V. OPERATION

1

Press POWER button to turn on the TV/VCR.

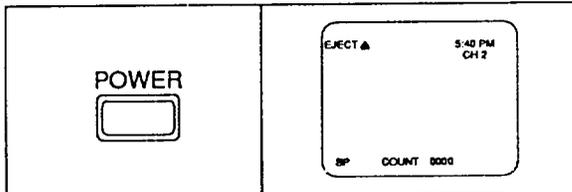

2

Select the desired channel with number button or CH./SET "▲" or "▼" button.

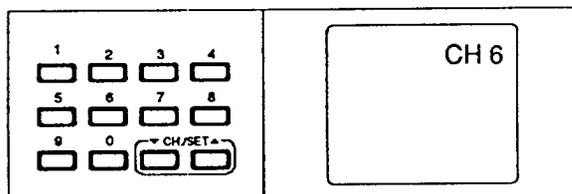

3

Adjust the VOLUME to desired listening level using the VOLUME "▲" or "▼" button.

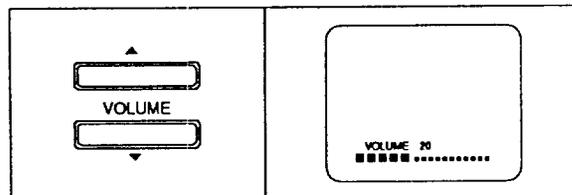

- ◆ You must use the remote control unit for the following steps.

4

Adjust picture controls for a natural looking image. Press MENU button. Select item 2 (TV SET UP) with number button or CH./SET "▲" or "▼" button.

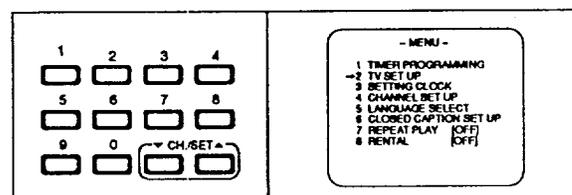

5

Press SELECT button. Select item 1 (PICTURE CONTROL) with number button or CH./SET "▲" or "▼" button.

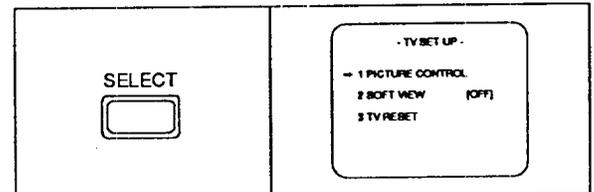

6

Press SELECT button repeatedly until desired control is displayed.

Each time you press SELECT button CONTRAST, BRIGHT, COLOR, TINT and SHARPNESS appear on the screen in order. (Example : CONTRAST)

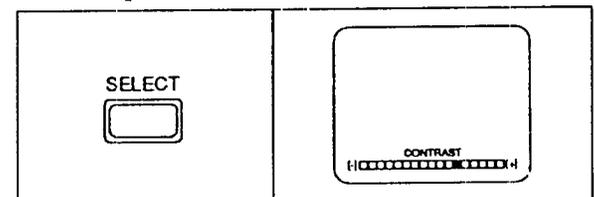

7

Adjust picture control by pressing CH./SET "▲" or "▼" button.

- ◆ Your TV/VCR's picture controls—CONTRAST, BRIGHT, COLOR, TINT and SHARPNESS—are preset to the default position. This is usually best, but if you need to make any further adjustments, use the following chart as a guide.

	CH./SET ▼	CH./SET ▲
CONTRAST	to decrease contrast	to increase contrast
BRIGHT	to decrease brightness	to increase brightness
COLOR	to pale	to brilliant
TINT	to purple	to green
SHARPNESS	to soft	to clear

TO PRESET THE PICTURE CONTROLS TO THE DEFAULT POSITION, SELECT ITEM 3 (TV RESET) AT STEP [5].

VIEWING AND RECORDING THE SAME PROGRAM

- ◆ You can only watch the same TV program that is being recorded.

1

Insert a cassette with erase-prevention tab intact. The unit turns on automatically.

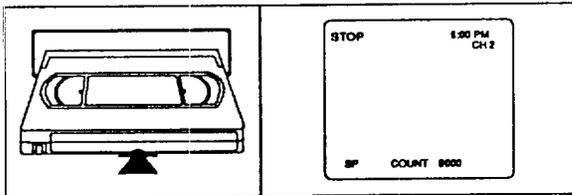

2

Ensure TIMER REC indicator is off. When TIMER REC indicator lights on, press POWER button to turn on.

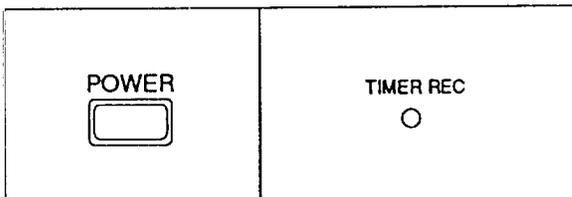

3

Press SPEED button on the remote control repeatedly until the desired recording speed is displayed. (Example : SP)

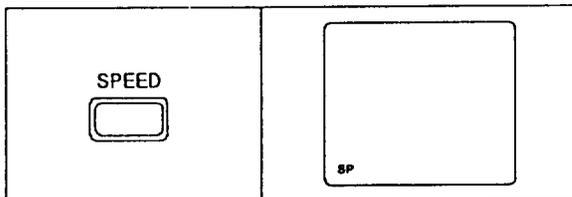

4

Select the program to be recorded by pressing the number button or the CH./SET "▲" or "▼" button.

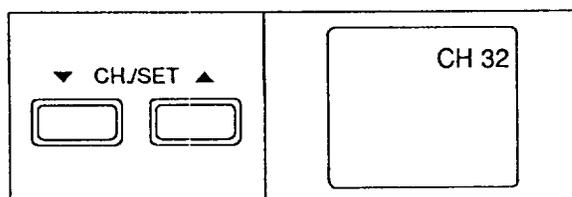

5

Press REC button.

The RECORD indicator lights up.

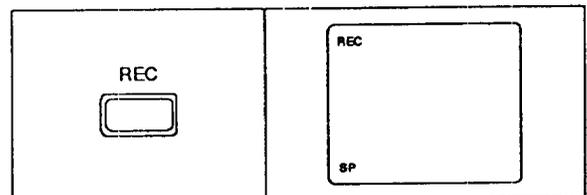

To skip some material while you are recording;

6

Press PAUSE/STILL button on the remote control.

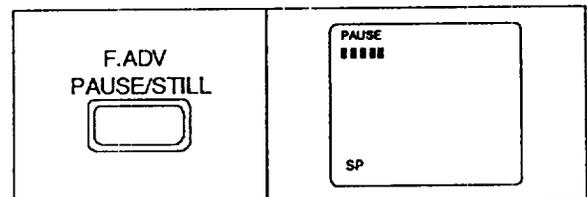

Note: If the TV/VCR is left in the Pause/Still mode more than 5 minutes in the Recording mode, It will automatically switch to the Recording mode. When in the Pause/Still mode, a display showing 5 "■" marks will appear on the screen. Each "■" mark represents one minute of Pause time. You may refer to this display for remaining pause time available.

7

Press PAUSE/STILL button or REC button on the remote control to resume recording.

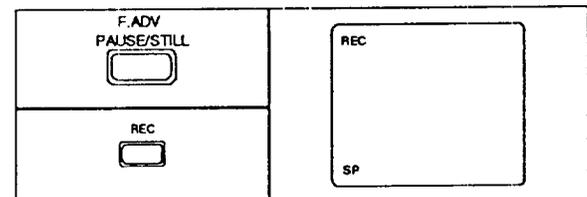

8

Press STOP button when recording is completed.

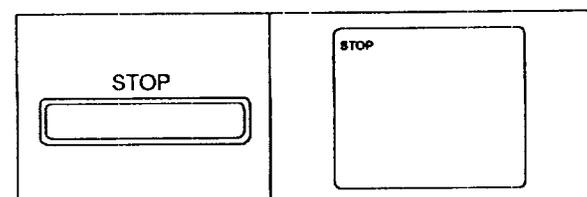

COUNTER MEMORY

The Memory can be used in the REWIND or F.FWD mode, to stop tape as tape approaches counter display of approx. 0000.

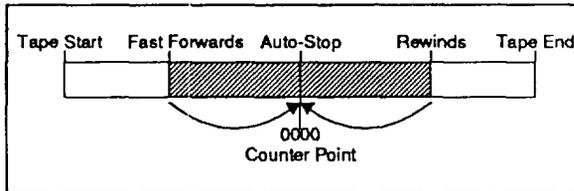

For example, this feature can be used to return the tape to a pre-selected position immediately after recording, or to repeatedly playback a certain portion of a tape.

◆ You must use the remote control unit for the following steps.

1

Before playback or recording, press SELECT button repeatedly until the counter number is displayed.

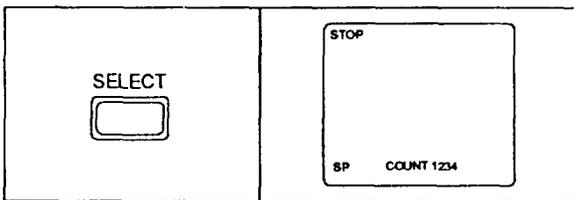

2

Press COUNTER RESET button. The counter reset to 0000.

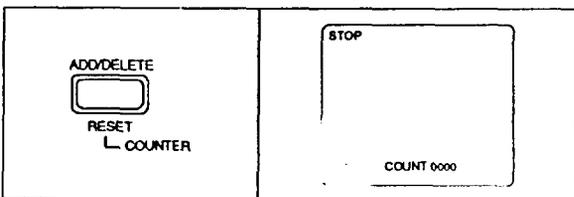

3

Press COUNTER MEMORY button.

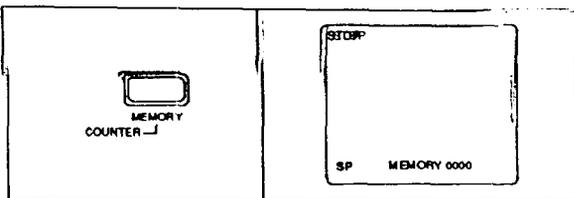

4

Press SELECT button repeatedly until the TV screen returns to TV mode.

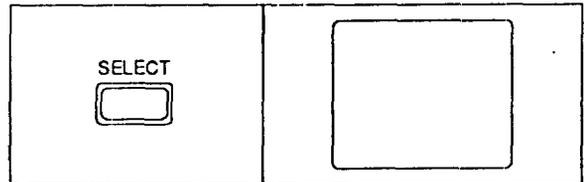

5

Press REC or PLAY button.

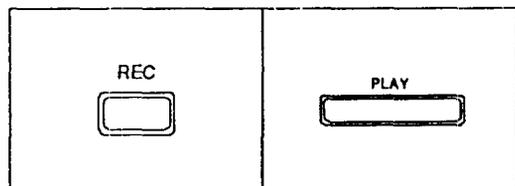

6

Press STOP button when recording or playback is completed.

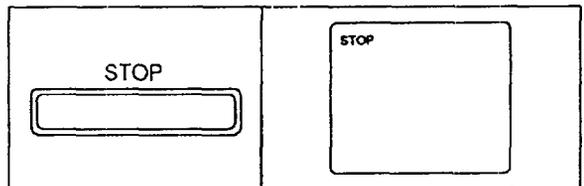

7

Press SELECT button so that Counter mode appears.

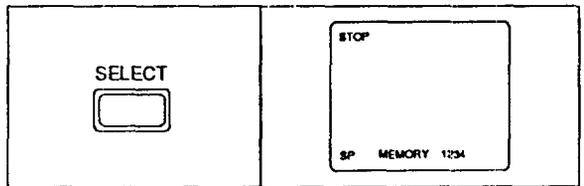

8

Press REW button.

The tape will stop automatically when the counter reaches to approx. 0000.

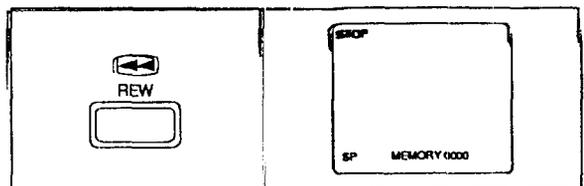

AUTOMATIC TIMER RECORDING

Automatic timer recording lets you set the TV/VCR to start and end a recording while you are away. Your TV/VCR has eight program timers. You can set seven events to record on a specific day, daily or weekly within 1 year period. You can set each program to record on a different channel and at a different recording speed.

SETTING THE TIMER PROGRAMS

Be sure the clock is set to the correct time before you use automatic timer recording.

In the example below, the timer is being set to record:

DATE	MAY 6th Thursday, 1993
SETTING TIME	from 7:30AM to 8:50AM
CHANNEL	CH.61
TAPE SPEED	LP

- ◆ You must use the remote control unit for the following steps.

1

Insert a cassette tape with erase-prevention tab intact. The unit turns on automatically.

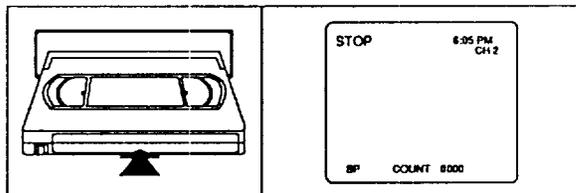

- ◆ If necessary, rewind or fast forward the tape to the point you want to start recording.

2

Press MENU button.

The main menu display on the TV screen.

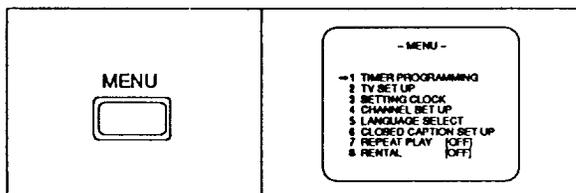

3

Select item 1 (TIMER PROGRAMMING) with number button or CH./SET "▲" or "▼" button.

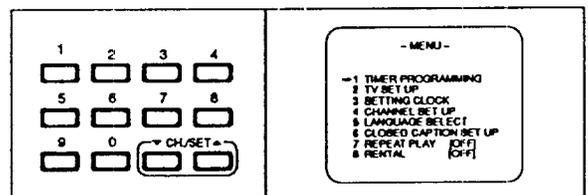

4

Press SELECT button.

The program number which is not set up flashes.

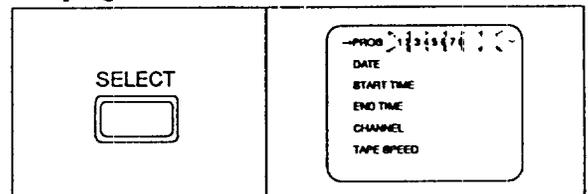

5

Select your desired program number with number button or CH./SET "▲" or "▼" button.

(Example: 4).

The program number 8 is used for setting Quick Set Program only. You cannot select number 8 in the procedure of Automatic Timer Recording.

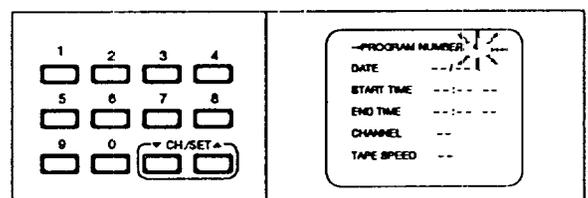

6

Press SELECT button. The MONTH digits flash.

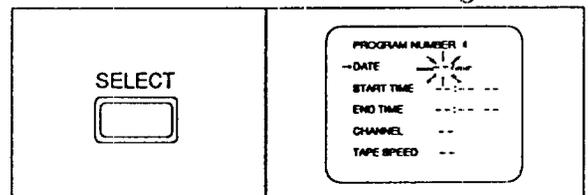

7

Enter your desired MONTH with number button or CH./SET "▲" or "▼" button. (Example:05).

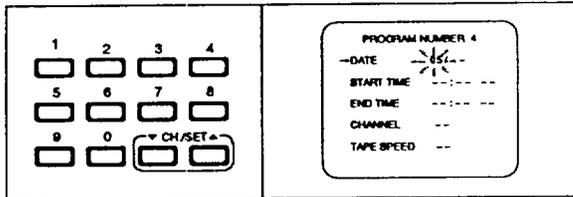

◆ After 1 second the day digits flash.

8

Enter your desired DAY with number button or CH./SET "▲" or "▼" button. (Example:06)
The day of the week changes automatically.

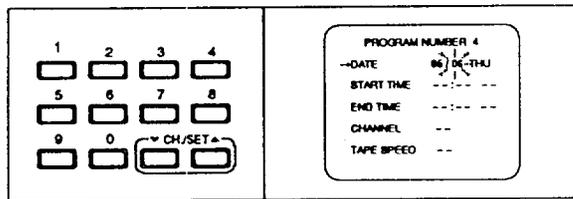

◆ After 1 second the start time hour digits flash.

9

Enter your desired HOUR with number button or CH./SET "▲" or "▼" button. (Example:07)

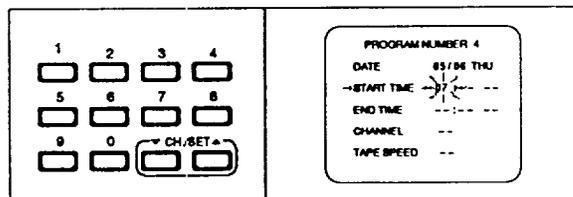

◆ After 1 second the start time minute digits flash.

10

Enter your desired MINUTE with number button or CH./SET "▲" or "▼" button. (Example:30)

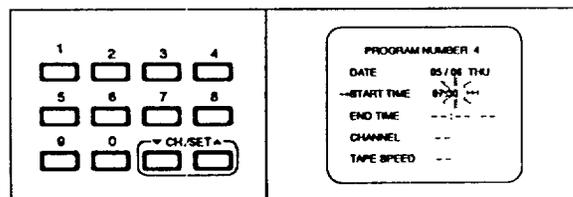

◆ After 1 second the AM/PM indicator flashes.

11

Enter 1 to select AM or enter 2 to select PM with number button or CH./SET "▲" or "▼" button. (Example: 1→AM)

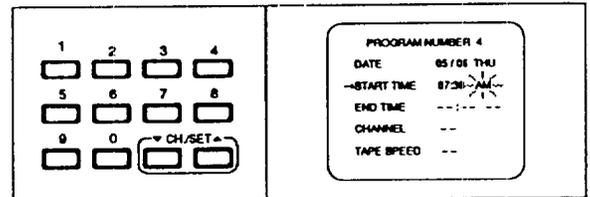

◆ After 1 second the end time hour digits flash.

12

Repeat steps [9]-[11] to set the end time. (Example: 08:50AM)

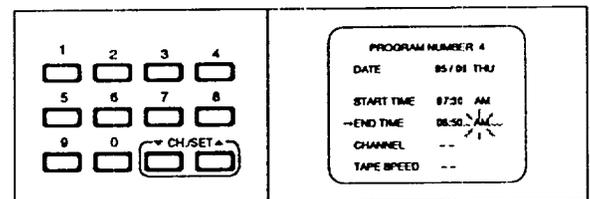

◆ After 1 second the channel digits flash.

13

Enter your desired CHANNEL with number button or CH./SET "▲" or "▼" button. (Example: 61)

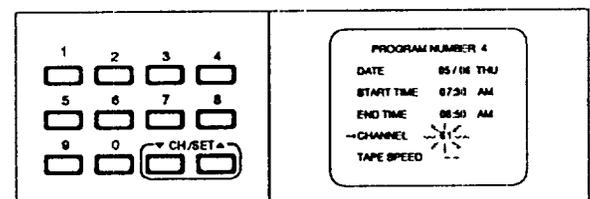

◆ After 1 second the tape speed digits flash.

14

Select your desired recording speed.
Enter 1 to select SP, enter 2 to select LP or enter 3 to select SLP with number button or CH./SET "▲" or "▼" button. (Example: 2→LP)

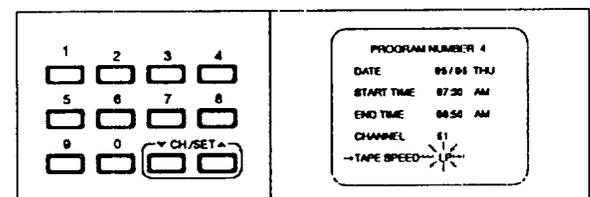

15

Press MENU or SELECT button on the remote control unit. Program 4 is now completed. To set another program, repeat steps [2] to [15].

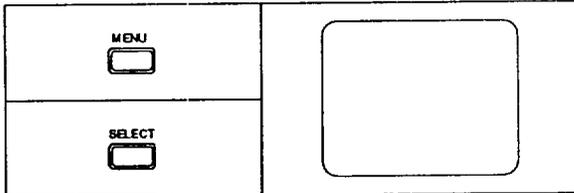

16

Press POWER button on the TV/VCR or on the remote control unit. The TIMER REC indicator lights up.

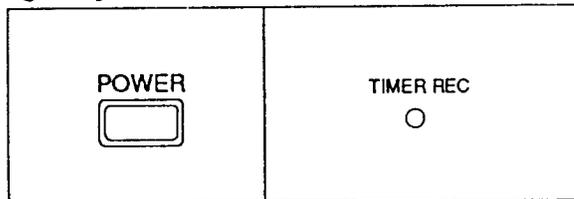

While watching TV, "TIMER REC STANDBY" starts flashing on the TV/VCR screen 2 minutes before the programmed start time.

You must turn off the TV/VCR to activate automatic timer recording.

Note: When the programs overlap, the earlier program has priority.

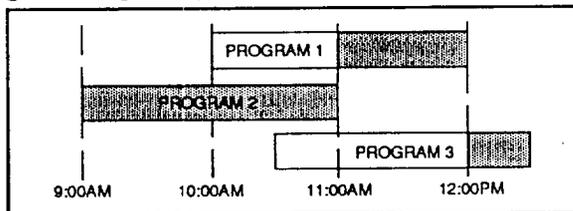

If you programmed as per as the above illustration the timer recording would be carried out as follows:

9:00AM - 11:00AM for PROGRAM 2

11:00AM - 12:00PM for PROGRAM 1

12:00PM - for PROGRAM 3

DAILY PROGRAM

To record a program at the same time on the same channel every day, follow steps [1] to [6] on page 22 then continue with step [7a] below.

7a

Press CH./SET "▲" or "▼" repeatedly or enter "00" with number button. "DAILY" appears on the TV screen.

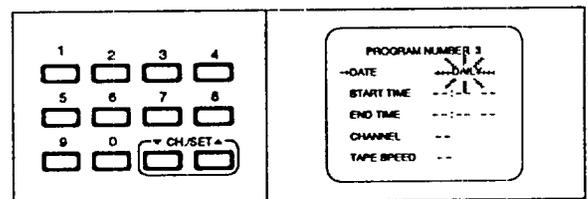

After 1 second, continue with step [9] on page 23 onwards.

WEEKLY PROGRAM

To record a program at the same time on the same channel every week, follow steps [1] to [6] on page 22 then step [7b] below.

7b

Press CH./SET "▲" or "▼" button repeatedly until your desired date of the week is displayed. (Example: W SUN)

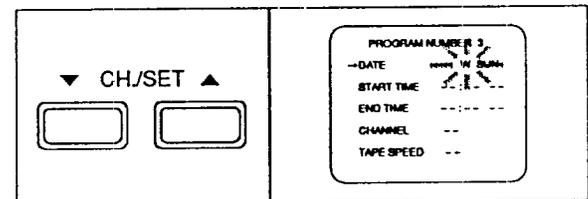

After 1 second, continue with step [9] on page 23 onwards.

TO CORRECT OR DELETE A PROGRAM

- ◆ Press DELETE button to go back one step from current step during steps [6]~[14].
- ◆ If you finished setting program, press SELECT button repeatedly (or press DELETE button to go back one step) until your desired digit flashes and reset program during steps [6]~[14].
- ◆ You may cancel the entire program by pressing DELETE button at step [5].

QUICK SET PROGRAM

You may set the TV/VCR to start and end recording one program within 24 hours by simply pressing QUICK SET PROGRAM button on the TV/VCR. It is easy for you to record today's TV program.

- ◆ Power must be on to set Quick Set Program.
- ◆ Clock must be set to the correct time before setting the timer.
- ◆ Quick Set Program is memorized to program number 8.

In the example below, the Quick Set Program is being set to record:

SETTING TIME from 10:00PM to 11:00PM
CHANNEL CH10
TAPE SPEED SP

Current time is 8:00PM.

Note: This function is not operative with the remote control.

1

Insert a cassette tape with its erasure prevention tab in place, if necessary, rewind or fast forward the tape to the point at which you want to begin recording.

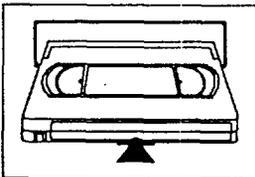

2

Press QUICK SET PROGRAM button on the TV/VCR.

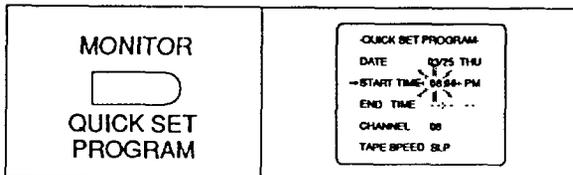

NOTE:

- 1) Key inputs for steps [2]-[10] should be done within 2 seconds, otherwise input mode will forward to next mode.
- 2) You may forward to next step when you press SELECT button on the TV/VCR.
- 3) When you press CLEAR button on the TV/VCR, all input data will be erased and return to Initial display (step. [2]).

3

Press SET "+" or "-" button until your desired start time hour is displayed. (Example: 10)

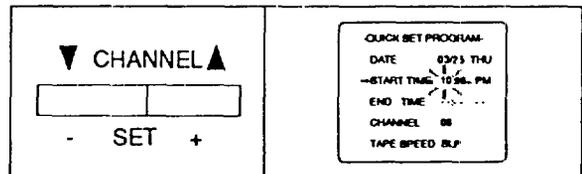

4

Press SET "+" or "-" button until your desired start time minute is displayed. (Example: 00)

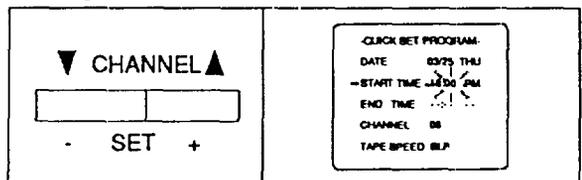

5

Press SET "+" or "-" button until AM or PM is displayed. (Example: PM)

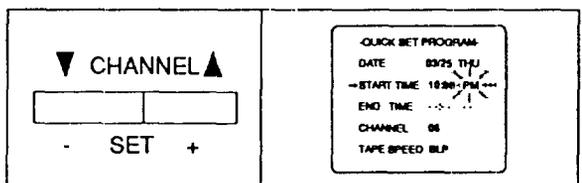

6

Press SET "+" or "-" button until your desired end time hour is displayed. (Example: 11)

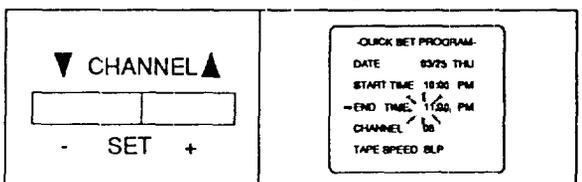

7

Press SET "+" or "-" button until your desired end time minute is displayed. (Example: 00)

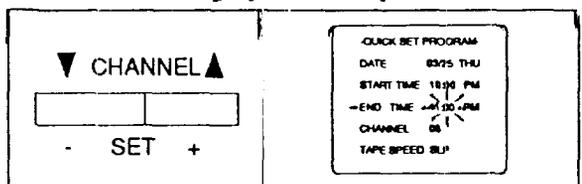

8

Press SET "+" or "-" button until AM or PM is displayed. (Example: PM)

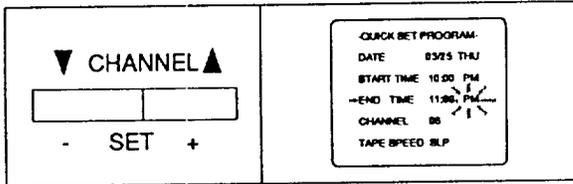

9

Press SET "+" or "-" button until your desired channel number is displayed. (Example: 10)

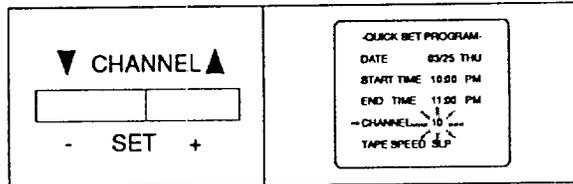

10

Press SET "+" or "-" button until your desired tape speed is displayed. (Example: SP)

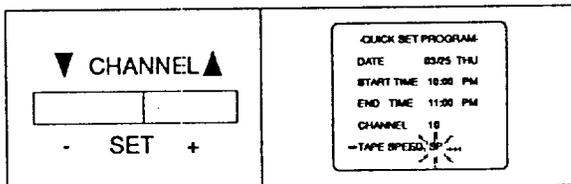

11

Press QUICK SET PROGRAM button or MENU button on the remote control.

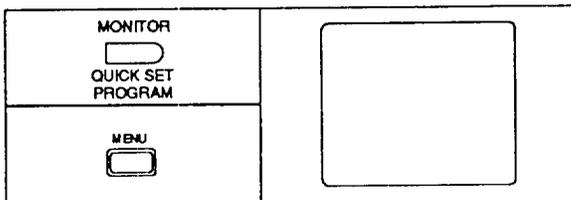

12

Press POWER button to set Quick Set Program. The TIMER REC indicator lights up.

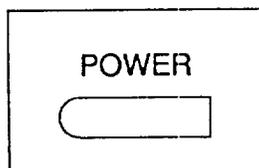

When the programs overlap, Quick Set Program has priority.

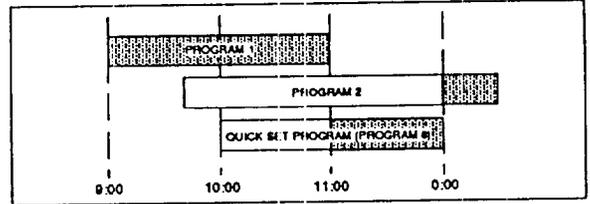

If you program as per the illustration the timer recording would be carried out as follows.

9:00-11:00 for PROGRAM 1

11:00-0:00 for QUICK SET PROGRAM (PROGRAM 8)

0:00- for PROGRAM 2

TO CANCEL A QUICK SET PROGRAM WHILE IN PROGRESS

Press STOP/EJECT button on the TV/VCR. The program will be canceled and the display returns to original mode.

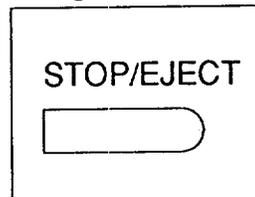

CHECKING THE START/END TIME

To check the start/end time and channel number, follow steps 1) ~ 5) below.

- 1) Press MENU button on the remote control.
- 2) Select item 1(TIMER PROGRAMMING) with number button or CH./SET ("+" or "-") button.
- 3) Press SELECT button.
- 4) Select program number 8 with number button or CH./SET ("+" or "-") button. "QUICK SET PROGRAM" appears on the TV screen.
- 5) Press MENU button. The screen returns to original mode.

AUTOMATIC TIMER RECORDING HINTS

- ◆ If there a power failure or the TV/VCR is unplugged for more than 10 seconds, the clock setting and all timer settings are lost. At this time, display will automatically return to the Clock Set mode when you choose program set mode.
- ◆ If two timer programs overlap, the one that starts first has priority. When the first program ends, the TV/VCR switches to record the remainder of the second program.
- ◆ Make sure the channel you want to record is properly tuned in advance.
- ◆ The erase-prevention tab on the cassette must be in place (or you must put tape over the hole). **Note:** A cassette without erase-prevention tab will be ejected when in the Timer Rec mode.
- ◆ It is not necessary to press REC button for timer recording.
- ◆ Recording begins automatically at the set Start time.
- ◆ If you are recording using the Automatic Timer Programmed, you may not operate the unit manually, but, you may still stop the recording by pressing STOP button on the TV/VCR. **Note:** STOP button on the remote control unit will not function in this mode.
- ◆ If the tape runs out before the end time, the TV/VCR will switch to the Stop mode immediately, and tape will be ejected.
- ◆ If a tape is not loaded or the erase-protection tab is removed, the TIMER REC indicator flashes and automatic timer recording cannot occur. Press POWER button to stop the flashing. Then, load a tape that allows recording.

CHECKING TIMER PROGRAMS

To check a program that is to be recorded using the Automatic Timer Program when the TV/VCR is in the Timer Record mode, turn on the TV/VCR. Press POWER button to exit the Timer Record mode. Then follow instructions in steps 2 to 5 on page 22. Information which was set for program will now appear.

CHECKING THE COUNTER, CLOCK AND CHANNEL NUMBER

To see the COUNTER, CLOCK and CHANNEL number on the TV screen, press the SELECT button on the remote control.

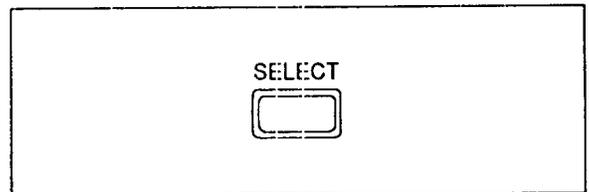

Each time you press the SELECT button on the remote control, TV screen will change as follows.

When the Closed Caption mode is OFF:

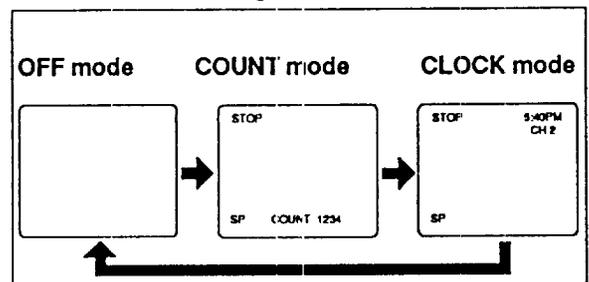

When the Closed Caption mode is ON: each mode will disappear after 5 seconds.

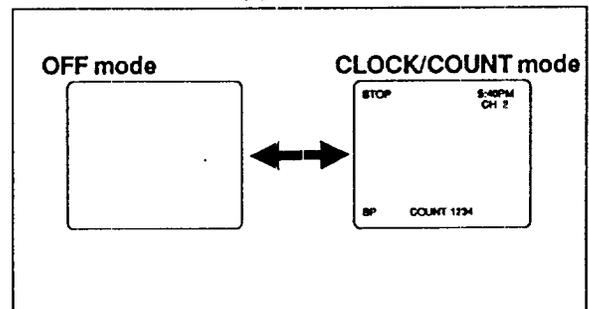

OTR (ONE TOUCH RECORDING)

The One Touch Record function enables you to record a program simply by pressing OTR button on the TV/VCR.

According to the table, simply press OTR button as many times as needed to set the desired recording length. The channel number to be recorded and recording length will be shown on the TV/VCR display.

1

Insert a cassette with erase-prevention tab intact. The unit turns on automatically.

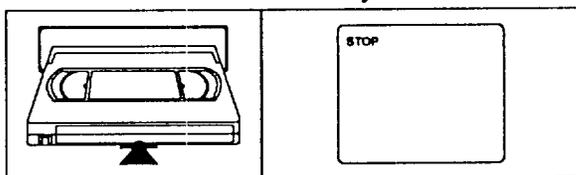

2

Select the program to be recorded.

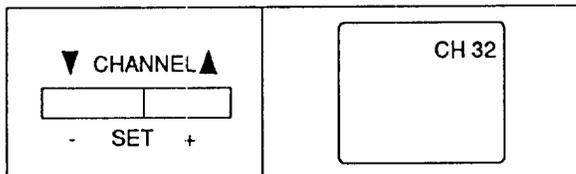

3

Press RECORD/OTR button on the TV/VCR. (Example: 4 pushes for 90 minutes)

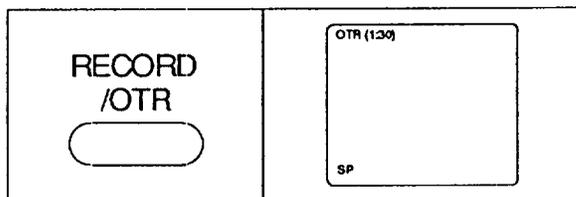

Recording starts if the RECORD/OTR button is pressed even while watching a TV program.

Push(es)	DISPLAY	LENGTH
1push	NORMAL REC MODE	
2 pushes	0:30	30 minutes
3 pushes	1:00	60 minutes
4 pushes	1:30	90 minutes
5 pushes	2:00	120 minutes
6 pushes	2:30	150 minutes
7 pushes	3:00	180 minutes
8 pushes	3:30	210 minutes
9 pushes	4:00	240 minutes
10 pushes	4:30	270 minutes
11 pushes	5:00	300 minutes
12 pushes	5:30	330 minutes
13 pushes	6:00	360 minutes
14 pushes	6:30	390 minutes
15 pushes	7:00	420 minutes
16 pushes	7:30	450 minutes
17 pushes	8:00	480 minutes
18 pushes	NORMAL REC MODE	

The timer on the screen counts down as the recording progresses.

Notes:

- ◆ When you push OTR button, you will extend recording time by 30 minutes at a time up to 8-hours (or to the end of the tape).
- ◆ To stop the OTR operation, press STOP button.
- ◆ When OTR button is pushed 18 times the TV/VCR will record continuously until the end of the tape.
- ◆ The recording length time remaining is indicated on the TV screen as the recording is started.
- ◆ Recording stops when 0:00 is reached.
- ◆ Please note that in the SLP (tape speed) mode maximum recording time, assuming the tape is started of the beginning, is 8 hours using T-160 (or 6 hours using T-120).

SETTING THE SLEEP TIMER

The sleep timer function enables you to shut off the power without pressing POWER button after a desired period.

◆ You must use the remote control unit for the following steps.

Press SLEEP button on the remote control repeatedly until desired SLEEP time is display.

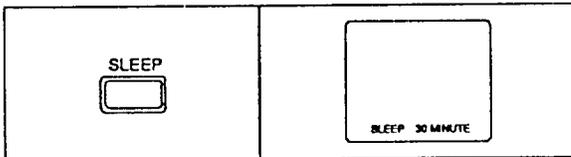

The shut off time can be determined by the number of times you press the button. (The sleep timer will be displayed on the screen when you press the SLEEP button on remote control.)

	SLEEP TIME	DISPLAY
1 push	0 minute	0 MINUTE
2 pushes	30 minutes	30 MINUTE
3 pushes	60 minutes	60 MINUTE
4 pushes	90 minutes	90 MINUTE
5 pushes	120 minute	120 MINUTE
6 pushes	0 minute	0 MINUTE

PLAYBACK

1

When a tape is inserted, the unit turns on automatically.

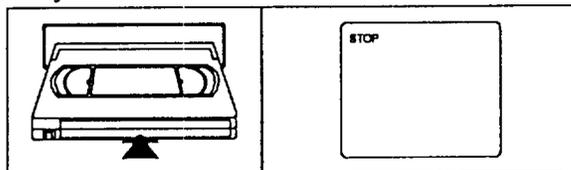

Note: If the erase-protection tab has been removed, the TV/VCR will start playback automatically.

2

If playback does not begin automatically, press PLAY button.

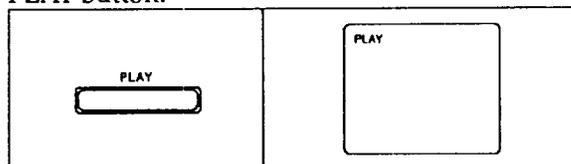

3

Press STOP button when playback is completed.

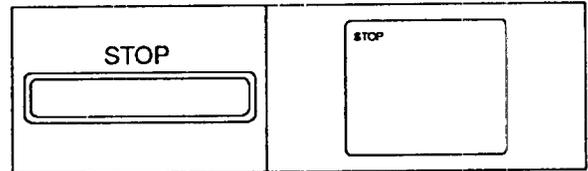

RENTAL PLAY

This function enables you to improve the picture quality when playing back worn cassettes such as those rented from a video shop.

Before playback, follow steps below.

1

Press MENU button on the remote control unit.

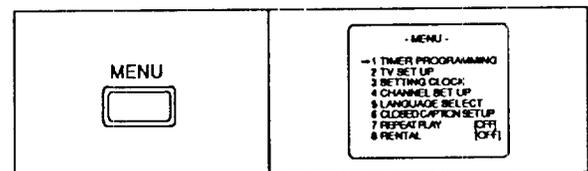

2

Select item 8 (RENTAL) with number button or CH./SET "▲" or "▼" button.

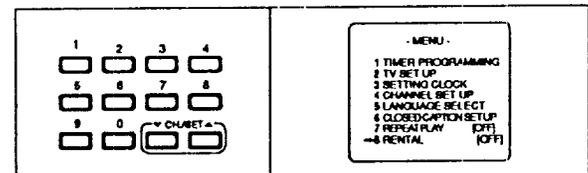

3

Press SELECT button repeatedly to select "ON".

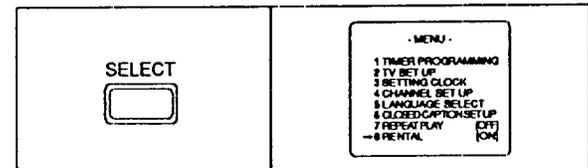

4

Press MENU button to return to original mode.

- ◆ Once you select the Rental Play mode, it stays in effect even after you turn off the TV/VCR.
- ◆ To exit the Rental Play mode, repeat steps [1] to [3]. Then, follow step [4], but select [OFF] for normal playback.

AUTO REPEAT PLAYBACK

This function enables you to repeat playback between the beginning and end of the tape. Before playback, follow steps below.

1

Press MENU button.

The main menu display on the TV screen.

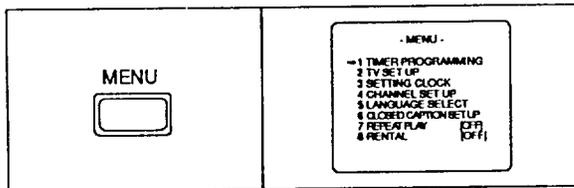

2

Select item 7 (REPEAT PLAY) with number buttons or CH./SET "▲" or "▼" button.

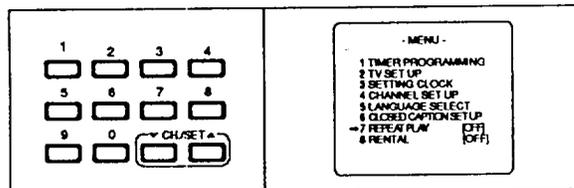

3

Press SELECT button repeatedly to select ON.

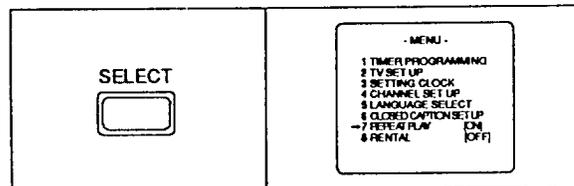

4

Press MENU button to return to original mode.

- ◆ Once you select the Repeat Play mode, it stays in effect even after you turn off the TV/VCR.
- ◆ To exit the Repeat Play mode, repeat steps [1] and [2]. Then, follow step [3], but select [OFF] instead of [ON] for normal play.
- ◆ If the rental play function is set ON, the "RENTAL PLAY ►" display has priority.

CLOSED CAPTION SYSTEM

You may watch dramas, movies and news etc. with captioning the dialogues and the contents of news if you want.

1

Press the MENU button.

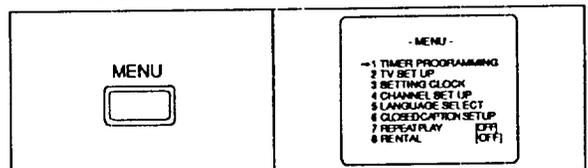

2

Select item 6 (CLOSED CAPTION SET UP) with number button or the CH./SET "▲" or "▼" button.

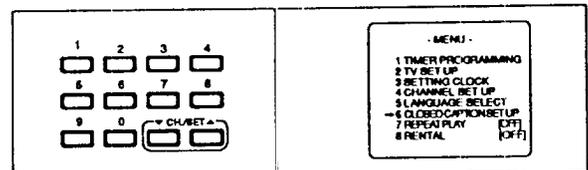

3

Press SELECT button.

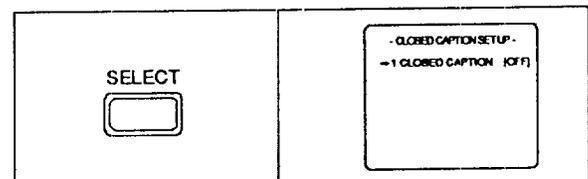

4

Press SELECT button to change "1 CLOSED CAPTION [ON]" and to appear "2 CAPTION MODE"

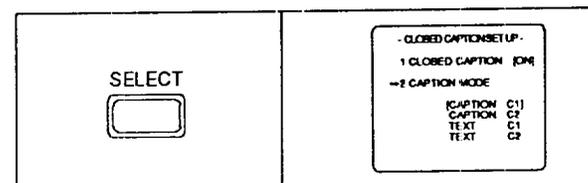

5

Select item 2(CAPTION MODE) with number button or CH./SET "▲" or "▼" button.

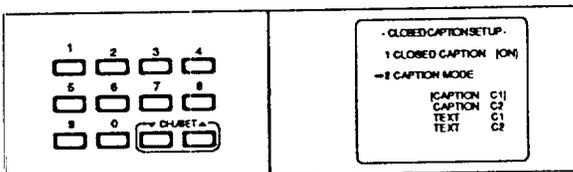

6

Press SELECT button repeatedly to select your desired broadcast. "[]" appears beside the selected one.

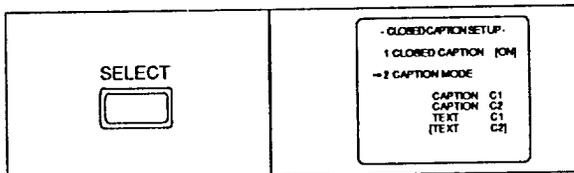

7

Press the MENU button. The selected caption broadcast appears on the TV screen.

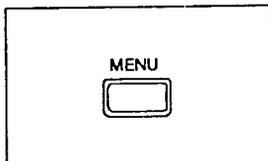

Note:

Not all programs are broadcast with closed captions. Your television is designed to provide error free closed captions from high quality antenna, cable and VCR signals. Conversely, poor quality signals are likely to result in caption errors or no captions at all. Common signal conditions which may cause captions errors are listed below;

- a) Automobile ignition noise.
- b) Electric motor brush noise.
- c) Weak snowy picture.
- d) Multiplex signal reception displaying picture ghosts or airplane flutter.
- e) Playback of poorly recorded or worn VCR tapes.
- g) Still mode or Slow motion playback.

AUTO REWIND-EJECT

When the end of a tape is reached during recording, playback, or fast-forward, the tape will automatically rewind to the beginning (or to the 0000 counter reading if the memory function is activated), eject, and the TV/VCR turns off.

Notes:

- ◆ This function is operative when Auto Repeat is set to the off position.
- ◆ The tape will not auto-rewind during timer recording or One Touch Recording.
- ◆ When tape is rewound to the preset memory position, tape will not be ejected and TV/VCR will not shut off.

VISUAL SEARCH

You may view the video program at a high speed in either a forward or reverse direction. When in the Play mode, press F.FWD button to view the tape at a fast speed in the forward direction. To view the tape at a fast speed in the reverse direction, press REW button. The sound will be muted. This feature is useful in finding or skipping over a particular section of a tape. When you wish to view the tape in normal speed, simply press PLAY button.

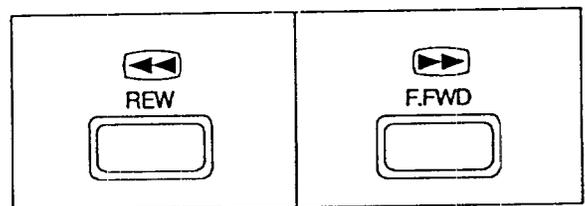

Notes:

- ◆ The picture will not be as good as in normal playback (SP or LP) during Visual Search.
- ◆ When video searching a pre-recorded tape, it may cause noise bars (white lines) to move vertically. Also, the picture color fluctuates on and off. This is not an indication of trouble.
- ◆ You will get best results when playing back tapes that were recorded in the SLP mode.

SUPER HIGH SPEED SEARCH (LP/SLP MODE)

For Visual Search in super high speed, press either F.FWD or REW button while the unit is in the Play mode. Then press again. The unit will now search in super high speed. Press once more either F.FWD or REW button back to high speed search. For normal playback, simply press PLAY button.

Note: Tape recorded in the LP, SLP mode will display a noise bar on the TV screen and the picture may revert to Black and White. This is normal.

STILL FRAME DURING PLAYBACK

If you press PAUSE/STILL button during playback, the picture will "freeze" on the TV screen. Only recorded tape in SLP mode shows clear picture. You may use this feature to study details of a particular screen. Press PLAY button again to continue playback.

Note: The TV/VCR will automatically switch to the Stop mode, if it is left in the Pause mode for more than five minutes.

SLOW MOTION

Press SLOW button to reduce the playback speed. The VCR mutes the sound during slow motion.

- ◆ Press PLAY button to return to normal playback.

Slow Tracking

You can reduce the noise lines by pressing CH. button ("▲" or "▼") in slow mode, too. But you cannot set center position in slow mode, and slow tracking adjustment will not be set automatically.

Note: Press SLOW button in Still mode and press CH. button ("▲" or "▼") until the streaks disappear. To return to Still mode, press PAUSE/ STILL button again.

This enables you to see the picture in its entirety without distracting noise lines.

VERTICAL HOLD CONTROL

Adjust to stabilize the picture when picture begins to vibrate.

This adjustments works only in the Still mode with CH ▲ or ▼ button.

TRACKING ADJUSTMENT

When playing pre-recorded tapes or tapes recorded on units other than your own, noise lines (black and white streaks) may appear on the playback picture. If this occurs, adjust the TRACKING control by pressing CHANNEL "▲" or "▼" button until the streaks disappear.

To set to center position, press both CH "▲" and "▼" buttons at the same time. (This function is operative only by buttons on Main Unit.)

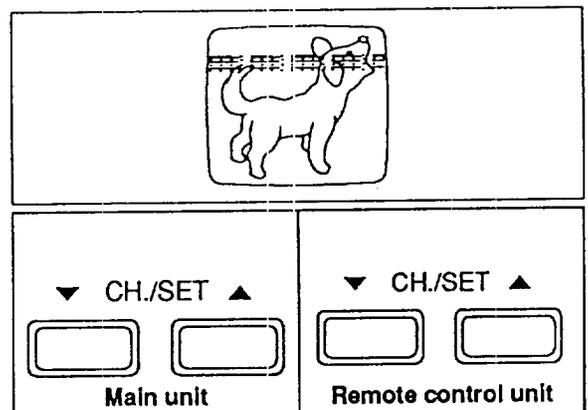

DEGAUSS

Magnetism from nearby appliances might affect the color of the TV picture. If this happens, move this unit away from the appliance. If the color is still not correct, disconnect power cord from AC outlet then reconnect it after 30 minutes over.

TROUBLESHOOTING GUIDE

If you have followed the instructions contained in this manual and have difficulty in operating your unit, locate the SYMPTOM in the left column below. Check the corresponding POSSIBLE CAUSE and CORRECTIVE ACTION columns to remedy the problem.

SYMPTOM	POSSIBLE CAUSE	CORRECTIVE ACTION
No power.	<ul style="list-style-type: none"> ◆ Power cord is not connected. ◆ The power is turned OFF. 	<ul style="list-style-type: none"> ◆ Connect power cord to AC outlet. ◆ Press POWER button to ON.
No picture and sound.	<ul style="list-style-type: none"> ◆ TV is not plugged into an active AC outlet. ◆ Antenna is not connected. ◆ No channel in memory. 	<ul style="list-style-type: none"> ◆ Plug power cord into an active AC outlet. ◆ Check antenna connection. ◆ Program tuner's memory.
Sound OK; poor picture.	<ul style="list-style-type: none"> ◆ Direction or condition of antenna is not good. ◆ Picture control is not good. ◆ Interconnecting cable is connected to another source. 	<ul style="list-style-type: none"> ◆ Adjust direction or replace antenna. ◆ Adjust picture controls. ◆ Connect incoming antenna directly to the television.
Picture OK; poor or no sound.	<ul style="list-style-type: none"> ◆ Volume control on remote control unit or main unit is in minimum position. ◆ MUTE button on the remote control unit is in the ON position. 	<ul style="list-style-type: none"> ◆ Adjust volume control on remote control unit or set. ◆ Press MUTE button.
Timer recording is not possible.	<ul style="list-style-type: none"> ◆ The timer program is set incorrectly. ◆ The power is turned ON. 	<ul style="list-style-type: none"> ◆ Set the timer program correctly. ◆ Press POWER button to OFF.
Record mode cannot be engaged.	<ul style="list-style-type: none"> ◆ The erase-prevention tab on cassette is missing. 	<ul style="list-style-type: none"> ◆ Place a piece of household transparent tape over missing erase-prevention tab on the tape cassette.
Picture is poor on playback.	<ul style="list-style-type: none"> ◆ The TRACKING control is not set to best position. 	<ul style="list-style-type: none"> ◆ Adjust TRACKING control for better picture.
Noise in picture on playback.	<ul style="list-style-type: none"> ◆ Video heads are dirty. 	<ul style="list-style-type: none"> ◆ Head cleaning is necessary, consult the nearest Sears Service Center.
No operation by infrared Remote Control.	<ul style="list-style-type: none"> ◆ No power to TV/VCR. ◆ Weak battery. 	<ul style="list-style-type: none"> ◆ Make sure the AC cord is connected to an AC outlet. ◆ Check the batteries in infrared Remote Control.

MAINTENANCE

CABINET CLEANING

- ◆ Wipe the front panel and other exterior surfaces of the unit with a soft cloth immersed in lukewarm water and wrung dry.
- ◆ Never use a solvent or alcohol. Do not spray insecticide liquid near the unit. Such chemicals may cause damage and discoloration to the exposed surfaces.

HEAD CLEANING

- ◆ Picture playback may become blurred or interrupted while the TV program received is clear. This does not mean that the recorded program has been erased. However, this problem may be caused by dirt.
Being accumulated on the videoheads after long periods of use, or usage of rental or old tapes. In this case, head cleaning requires highly technical attention, therefore consult the nearest Sears Service Center. Clean heads only when problems occur.

SERVICING

- ◆ Should your unit become inoperative, do not try to correct the problem by yourself. There are no user-serviceable parts inside. Switch power off, unplug the power cord, and take the unit to your nearest Sears Service Center for servicing.

SPECIFICATIONS

GENERAL SPECIFICATIONS

CRT	: 19 inch in-line gun, 90° deflection tube
Television system	: NTSC-M
Video heads	: Rotary 4-head Double Azimuth Video System
Tape width	: 1/2 inch
Tape speed	
SP	: 33.40mm/sec.
LP	: 16.67mm/sec.
SLP	: 11.12mm/sec.
Tuner channel	
TV VHF Low	: #2~#6
TV VHF High	: #7~#13
TV UHF	: #14~#69
CATV	
VHF	: 5A
MID band	: A5~A1, A~I
SUPER band	: J~W
HYPER band	: W+1~W+84
Terminals:	
Antenna input	: VHF/UHF 75 ohms unbalanced
Video input	: RCA connector
Audio input	: RCA connector

ELECTRICAL SPECIFICATIONS

Video input level	: 0.5~2.0V _{p-p}
Audio input level	: -15dBs
Video S/N ratio	: More than 46dB
Audio S/N ratio	: More than 43dB

OTHER SPECIFICATIONS

Power requirement	: AC 120V/60Hz
Power consumption	: 95W
Dimensions	: H: 18-3/4" (477mm) W: 19" (482mm) D: 17-7/8" (455mm)
Weight	: 44 lbs (20 kg)
Accessories	: Remote Control 2 "AA" Batteries Dipole Antenna Matching Adaptor Owner's Manual

◆ Design and specifications are subject to change without notice.

TV/VCR COMBINATION

LIMITED WARRANTY

This product is exclusive to and is warranted solely by Sears. For 90 days from the date of purchase, Sears will repair any defect in material or workmanship in this TV/VCR combination, free of charge. For one year from the date of purchase, Sears will supply, at no charge, replacement for defective parts.

This above warranty coverage applies only to TV/VCR combinations which are used for private household purposes.

LIMITED WARRANTY ON PICTURE TUBE

After one year from the date of purchase and up to two years, Sears will furnish, free of charge, a replacement for the picture tube, if defective. You pay for labor.

Warranty service is available by returning the TV/VCR combination to the nearest Sears Service Center/Department in the United States. This warranty applies only while this product is in use in the United States. For service after the warranty expires, it is recommended that this product be returned to the nearest Sears Service Center.

This warranty gives you specific legal rights, and you may also have other rights which vary from state to state.

Should a need ever exist for repair parts or service:

For repair service:

Call 1-800-4-Repair
(1-800-473-7247)

For replacement parts information and ordering:

Call 1-800-FON-Part
(1-800-366-7278)

Sears, Roebuck and Company, Dept.817WA
Hoffman Estates, IL 60179