

 Advanced Video Imaging

**OPERATING GUIDE  
&  
WARRANTY**

**ZENITH**

THE QUALITY GOES IN BEFORE THE NAME GOES ON<sup>®</sup>

**¡Aviso para nuestros  
clientes de habla hispana:  
consulte la información que  
aparece al final de este manual!**

**Direct-View Color TV  
MTS Stereo Audio  
Picture-In-Picture  
Surround Sound**



recycled paper  
50 percent

**Return the Product Registration  
Card, and your TV could be free!**



## WARNING

**RISK OF ELECTRIC SHOCK  
DO NOT OPEN**



**WARNING:** TO REDUCE THE RISK OF ELECTRIC SHOCK DO NOT REMOVE COVER (OR BACK). NO USER SERVICEABLE PARTS INSIDE. REFER TO QUALIFIED SERVICE PERSONNEL.

TO PREVENT FIRE OR SHOCK HAZARDS, DO NOT EXPOSE THIS PRODUCT TO RAIN OR MOISTURE.



The lightning flash with arrowhead symbol, within an equilateral triangle, is intended to alert the user to the presence of uninsulated "dangerous voltage" within the product's enclosure that may be of sufficient magnitude to constitute a risk of electric shock to persons.



The exclamation point within an equilateral triangle is intended to alert the user to the presence of important operating and maintenance (servicing) instructions in the literature accompanying the appliance.

### Safety Tips

Refer to the "Safety Tips" booklet that came with your product for important safety considerations.

### Note to Cable TV System Installer

This reminder is provided to call the cable TV system installer's attention to Article 820-40 of the NEC that provides guidelines for proper grounding and, in particular, specifies that the cable ground shall be connected to the grounding system of the building, as close to the point of the cable entry as practical.

### Power-Cord Polarization

This product is equipped with a polarized alternating-current line plug (a plug having one blade wider than the other.) This plug will fit into the power outlet only one way. This is a safety feature. If you are unable to insert the plug fully into the outlet, try reversing the plug. If the plug should still fail to fit, contact your electrician to replace your obsolete outlet. Do not defeat the safety purpose of the polarized plug.

### CAUTION

To prevent electric shock, match wide blade of plug to wide slot, fully insert.

### ATTENTION

Pour éviter les chocs électriques, introduire la lame la plus large de la fiche dans la borne correspondante de la prise et pousser jusqu'au fond.

# CONTENTS

## INTRODUCTION

Welcome . . . . .	ii
Installation Considerations . . . . .	ii

## CONNECTIONS FOR YOUR TV

Connection Center on Back of TV . . . . .	1-1
Other A/V Jacks on TV . . . . .	1-1
Step 1. Make Basic Connection to TV . . . . .	1-2
Step 2. Make VCR Connections to TV . . . . .	1-3
Step 3. Make Super-VHS VCR Connections to TV . . . . .	1-4
Step 4. Make A/V Connections to Auxiliary A/V Jacks (VIDEO 3 IN or S-VIDEO 2 IN) . . . . .	1-4
Step 5. Make Connections to Monitor Out Jacks . . . . .	1-4
Step 6. Make Surround Sound Connections to TV . . . . .	1-5
Step 7. Make External Speaker Connections to TV . . . . .	1-5
Step 8. Make Audio Connection to Stereo Amplifier . . . . .	1-6

## THE FIRST TIME YOU OPERATE YOUR TV

Step 1. Connect the Power . . . . .	2-1
Step 2. Select Your Viewing Source . . . . .	2-1
Step 3. Use Auto Program . . . . .	2-1
Step 4. Time Functions . . . . .	2-1
Step 5. Use Other Options . . . . .	2-2

## REMOTE CONTROL MODEL SC2400

Operation . . . . .	3-1
Installing Batteries . . . . .	3-1

## REMOTE CONTROL MODEL MBR3430

Operation . . . . .	4-1
Choose the Operating Mode . . . . .	4-1
TV Operations . . . . .	4-2
VCR Operations . . . . .	4-3
Cable-TV Operations . . . . .	4-4
Preparation for Use . . . . .	4-5
Installing Batteries . . . . .	4-5
Programming Brand Codes . . . . .	4-6
TV, VCR and Cable-TV Operating Codes . . . . .	4-7

## QUICK REFERENCE TO ON-SCREEN MENUS

Available Menus . . . . .	5-1
Summary of Menu Items . . . . .	5-1
Menu Operation Example . . . . .	5-3

## SOURCE MENU

Source Selection . . . . .	6-1
Source Identification . . . . .	6-1

## SETUP MENU

Auto Program . . . . .	7-1
Ch. Add/Del . . . . .	7-1
Ch. Labels . . . . .	7-2
Tuning Band . . . . .	7-3
Auto Tuning . . . . .	7-3
Source ID . . . . .	7-3
Clock Set . . . . .	7-4
Captions . . . . .	7-4

## AUDIO MENU

Bass . . . . .	8-1
Treble . . . . .	8-1
Balance . . . . .	8-1
Audio . . . . .	8-1
SEQ . . . . .	8-1
Surround . . . . .	8-1

## VIDEO MENU

Contrast . . . . .	9-1
Brightness . . . . .	9-1
Color . . . . .	9-1
Tint . . . . .	9-1
Sharpness . . . . .	9-1
Color Temp . . . . .	9-1
Video Filter . . . . .	9-1
Auto Flesh . . . . .	9-1
Picture Pref . . . . .	9-1

## PIP MENU

Ch. Guide . . . . .	10-1
Ch. Review . . . . .	10-2
PIP Source . . . . .	10-2
PIP Size . . . . .	10-3
PIP Color . . . . .	10-3
PIP Tint . . . . .	10-3

## PIP OPERATION AND CONNECTIONS

PIP Overview . . . . .	11-1
Typical Connections . . . . .	11-1
How to Select Main Picture & PIP Source . . . . .	11-3
PIP Functions . . . . .	11-4

## MAINTENANCE AND TROUBLESHOOTING

Caring for Your TV . . . . .	12-1
Extended Absence . . . . .	12-1
TV Picture Interference . . . . .	12-1
Before Calling for Service . . . . .	12-2

## Product Registration Card

## Recommended Accessories For Your Television

## Aviso para nuestros clientes de habla hispana

## Your Zenith Warranty

## HOW TO USE YOUR OPERATING GUIDE

THIS OPERATING GUIDE DESCRIBES A FAMILY OF TV MODELS. SOME MODELS HAVE FEATURES THAT ARE NOT PROVIDED ON OTHER MODELS, SUCH AS AUXILIARY JACKS. DIFFERENT CONTROL PANELS AND REMOTE CONTROLS MAY BE USED FROM MODEL-TO-MODEL. REFER TO THE APPLICABLE SECTIONS OF THIS OPERATING GUIDE FOR THE FEATURES AND ITEMS PROVIDED WITH YOUR TV.

---

# INTRODUCTION

---

## WELCOME

Welcome into the family of Zenith Color Television owners. This guide provides instructions on how to operate your new TV. It is supplemented by a booklet containing Safety Tips. We urge you to read these publications carefully so that you will receive full enjoyment from your new Zenith TV for many years to come.

Your new TV has been designed and built to give you the very best in quality, features and performance. There are thousands of Zenith authorized service centers throughout the U.S., Canada and Mexico who can attend promptly and effectively to ordinary service needs.

If you should have an unusual performance or service problem that cannot be satisfactorily resolved by your Zenith dealer or Zenith authorized service center, contact us at:

### Zenith Electronics Corporation

Customer Service Department

1000 Milwaukee Avenue

Glenview, IL 60025-2493

Telephone: (708) 391-8752

Mon-Fri, 8:00 a.m. - 4:30 p.m. Central Time

Provide the model number, serial number, and date of purchase or original installation, with a full explanation of the problem and the service history. We will welcome the opportunity to look into your specific question or problem and to be of assistance in resolving it promptly.

The model and serial numbers of your new TV are located on the back of the TV cabinet. For your future convenience and protection, we suggest that you record these numbers here:

Model No. \_\_\_\_\_

Serial No. \_\_\_\_\_

---

## INSTALLATION CONSIDERATIONS

### Before you install your TV...



**Ventilation** — Proper ventilation keeps your TV running cool. Air circulates through perforations in the back and bottom of the cabinet. Do not block these vents or you will shorten the life of your TV.



**Power Source** — Your TV is designed to operate on normal household current, 120 volt 60 Hertz AC. Do not attempt to operate it on DC current.



**Power Cord** — Your power cord has a polarized plug as required by Underwriters' Laboratories. It has one regular blade and one wide blade and fits only one way into a standard electrical outlet. If the blades will not enter either way, your outlet is very old and non-standard. A new outlet should be installed by a qualified electrician.



**Safe Operation** — Your TV is manufactured and tested with your safety in mind. However, unusual stress caused by dropping or mishandling, exposure to flood, fire, rain or moisture, or accidental spilling of liquids into the TV, can result in potential electrical shock or fire hazards. If this happens, have your TV checked by a service technician before using it again.

**Please read and observe each safety point in the "Safety Tips" folder when installing and using your TV.**

### VIDEO GAMES AND OTHER FIXED

**PATTERN DISPLAY CAUTION** — If you use your TV for video games, teletext or other fixed displays, avoid setting the BRIGHTNESS control for an excessively bright picture. A bright, fixed pattern, if used for long periods of time, can result in a permanent imprint on the TV picture tube. You can reduce this possibility by alternating the use of the fixed pattern display with normal TV picture viewing, by turning down the CONTRAST control for sustained fixed pattern use, and by turning off the fixed pattern display when not in use.

**PLUGGING IN YOUR TV** — Be sure to plug your TV into an "unswitched" AC power source. The "switched" AC outlets found on some video equipment will not continue supplying power to the TV once the equipment is turned off. If the power to the TV is interrupted, you will have to reset the clock in the TV to the current time.

# CONNECTIONS FOR YOUR TV

## CONNECTION CENTER ON BACK OF TV

**ANT/CABLE 1 or ANT/CABLE 2**  
75-ohm antenna-type connections to your TV. Attach your antenna, cable-TV line or VCR to either of these jacks.

**LOOP OUT TO DECODER**  
Use this output to route the cable-TV signal back to the decoder supplied by your cable-TV system.

**VIDEO 1 IN or VIDEO 2 IN**  
Baseband audio and video input from a VCR or other A/V component.

**VIDEO 1 LOOP OUT**  
Use these jacks to send the incoming audio and video signals (from VIDEO 1 IN) to another A/V component, such as a second VCR.

**EXTERNAL AMP**  
Standard phono jack connectors for output to the customer's audio amplifier or Terminals for connecting external speakers.

**SPEAKERS EXT/INT**  
EXT position: TV's speakers are off.  
INT position: TV's speakers are on.

**SURROUND SPEAKER**  
Terminal connectors for output to optional surround sound speakers.

**S-VIDEO 1 IN**  
Audio and video input from a Super-VHS VCR.

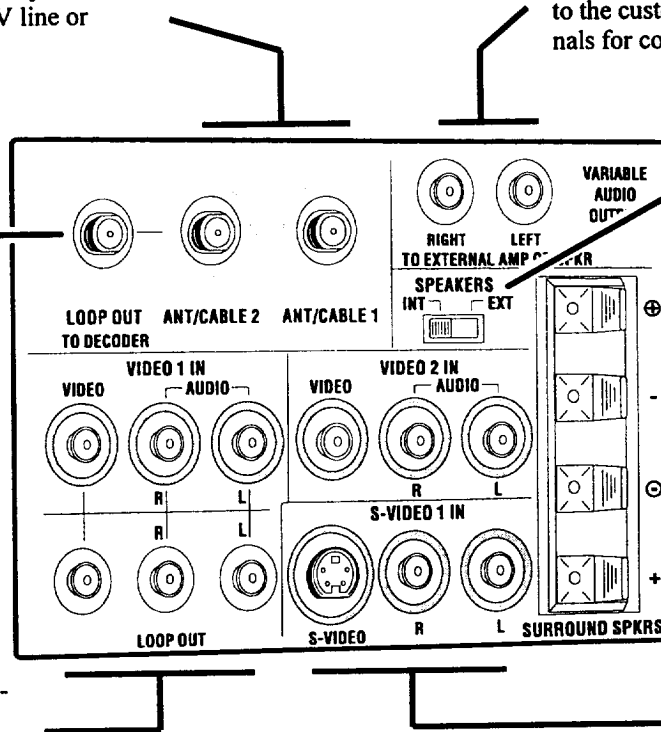

Some connections require additional cables or equipment which are not supplied with the TV.

## OTHER A/V JACKS ON TV (Some Models)

**S-VIDEO 2 IN**  
Audio and video input from a Super-VHS VCR.

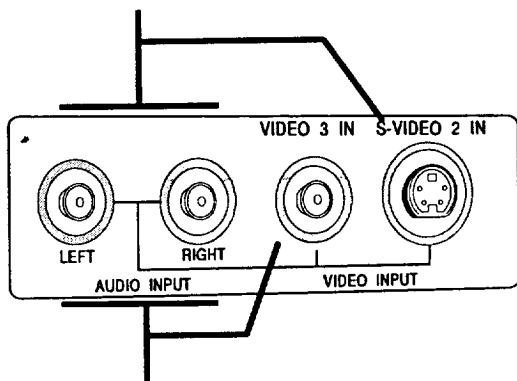

**VIDEO 3 IN**  
Baseband audio and video input from a camcorder or other A/V component.

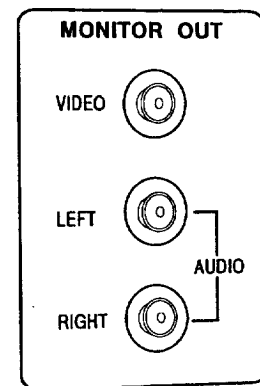

**MONITOR OUT**  
Fixed-level baseband audio and video output to a monitor or other A/V component. Program currently being watched on your TV is provided at these jacks.

# CONNECTIONS FOR YOUR TV

## STEP 1. MAKE BASIC CONNECTION TO TV

Select the hook up that best fits your needs. See the following diagrams.

**NOTE:** The antenna may be connected to the ANT/CABLE 2 jack, however, connecting to the ANT/CABLE 1 jack may produce a better picture in weak signal areas.

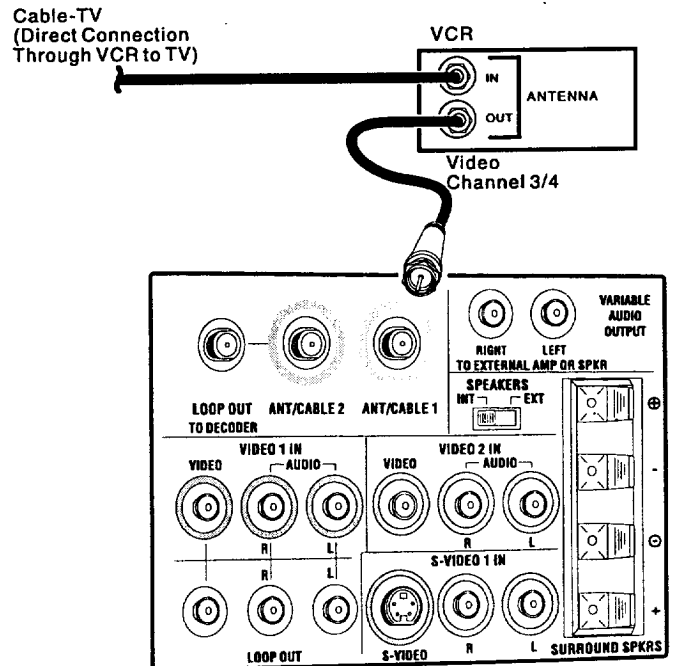
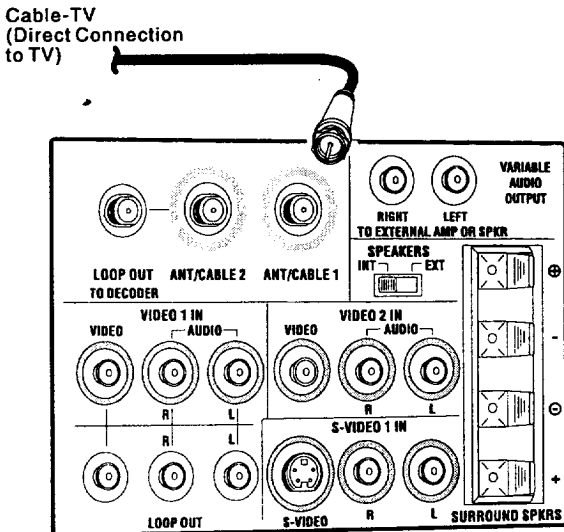
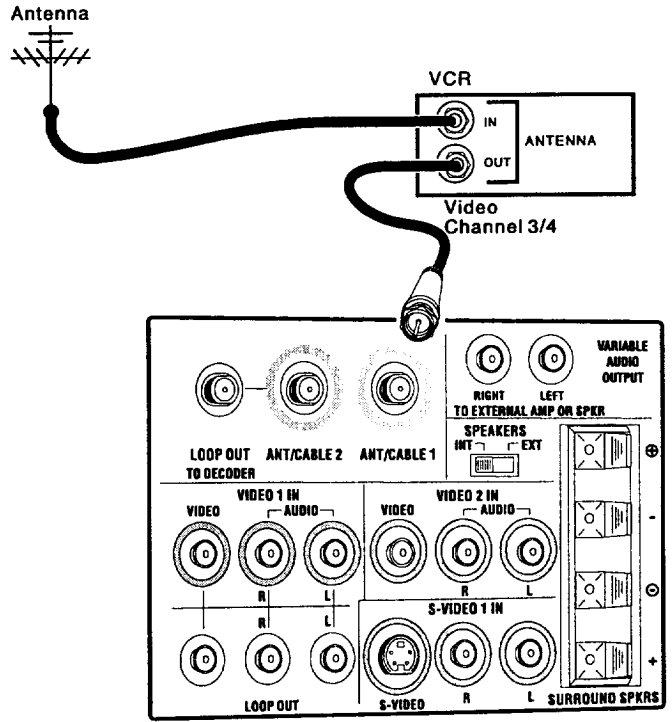
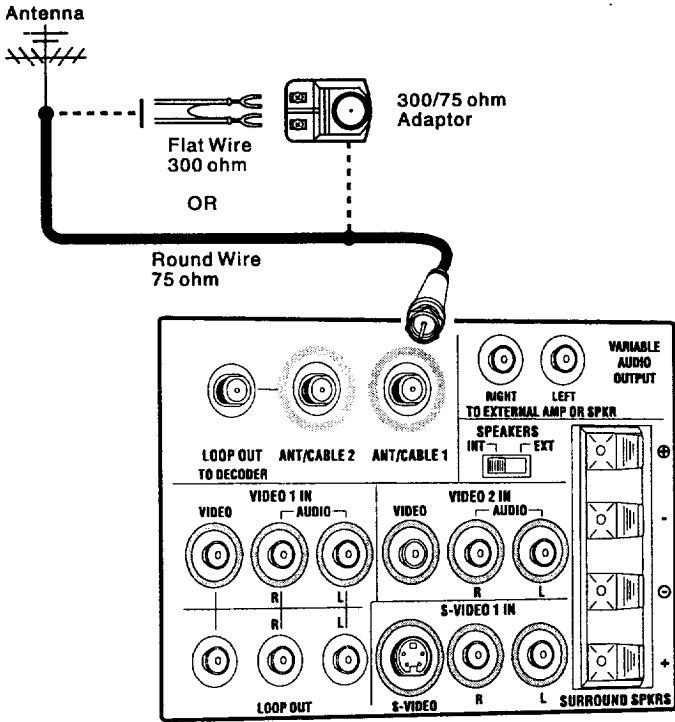

(continued on next page)

# CONNECTIONS FOR YOUR TV

## STEP 1. MAKE BASIC CONNECTION TO TV

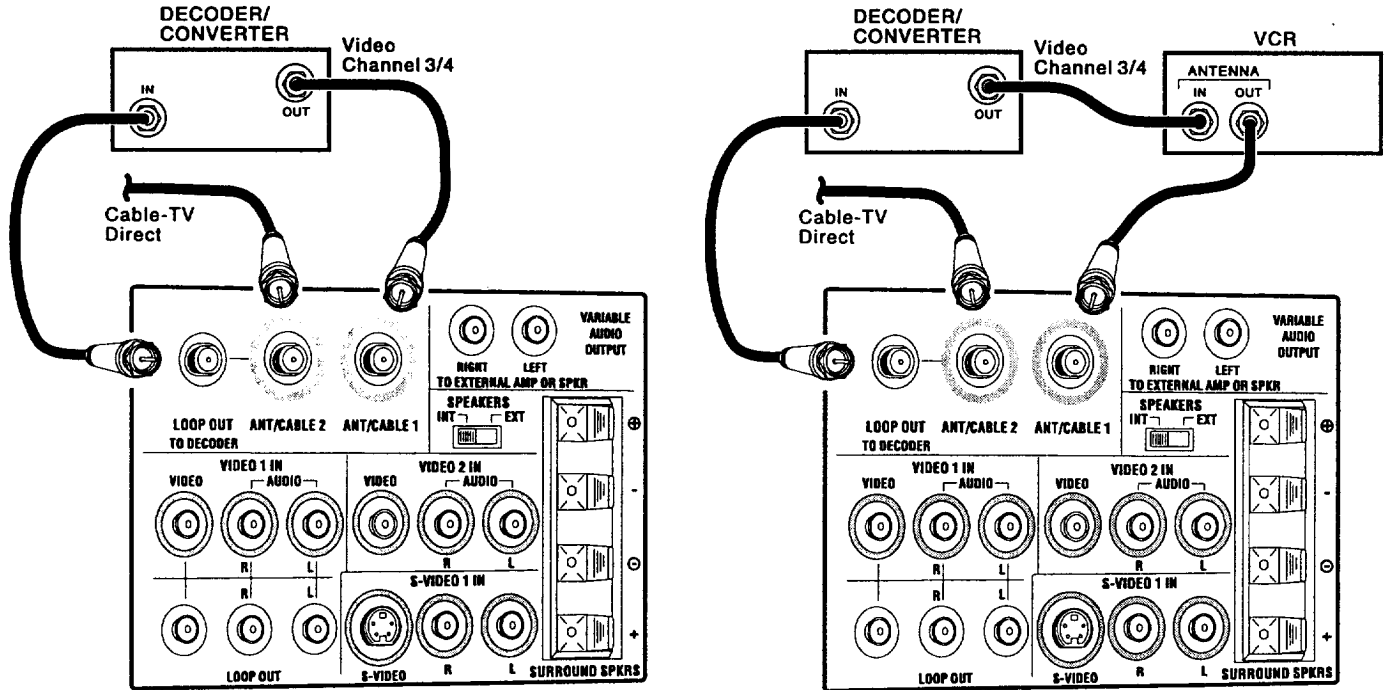

## STEP 2. MAKE VCR CONNECTIONS TO TV

If you have a stereo VCR, you must make the A/V connections shown in order to hear stereo sound while playing a tape.

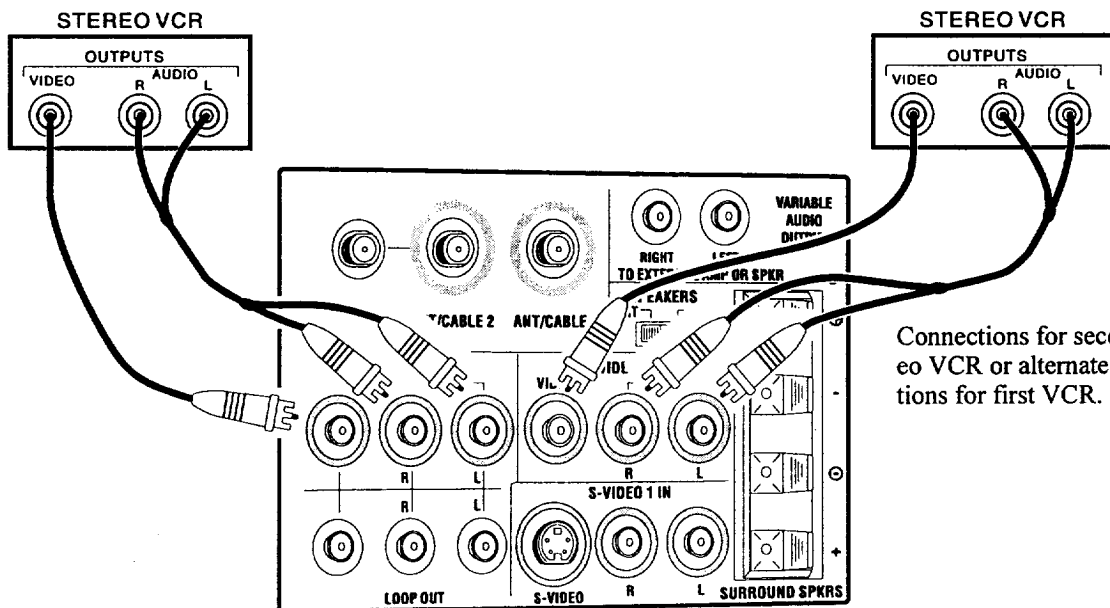

Connections for second stereo VCR or alternate connections for first VCR.

# CONNECTIONS FOR YOUR TV

## STEP 3. MAKE SUPER-VHS VCR CONNECTIONS TO TV

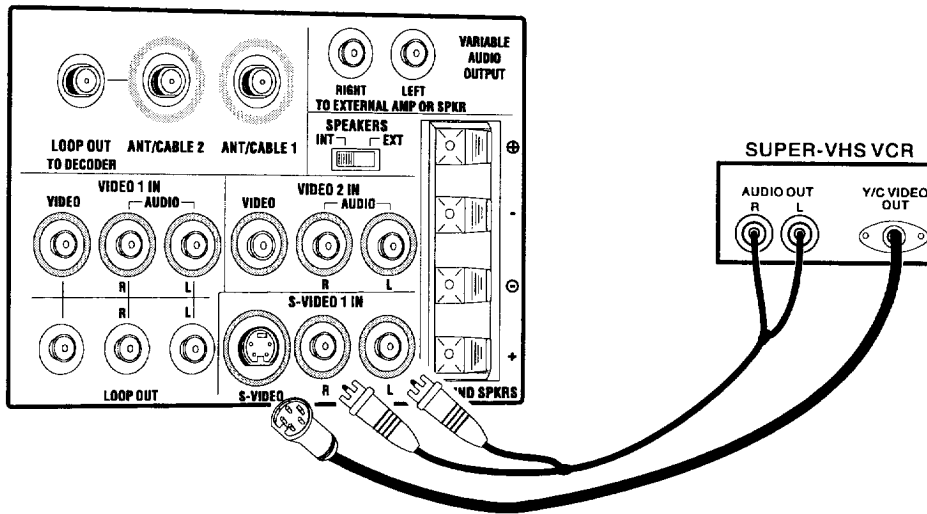

## STEP 4. MAKE A/V CONNECTIONS TO AUXILIARY A/V JACKS (VIDEO 3 IN OR S-VIDEO 2 IN)

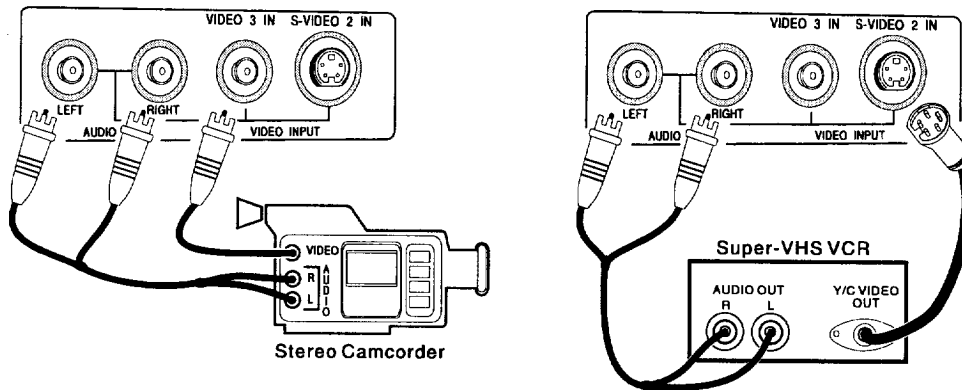

## STEP 5. MAKE CONNECTIONS TO MONITOR OUT JACKS

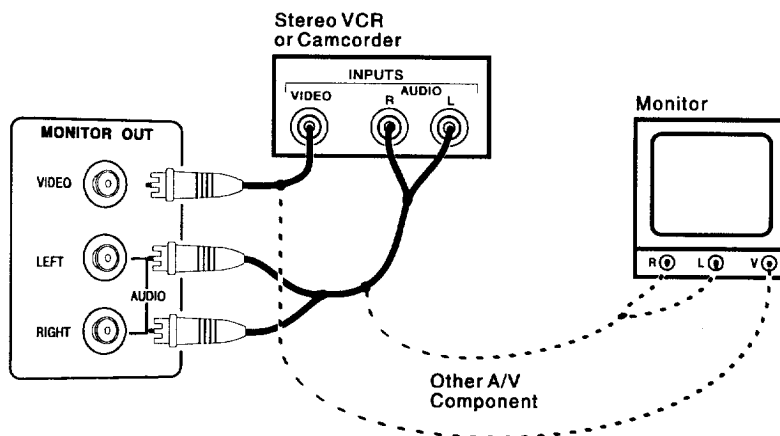



# CONNECTIONS FOR YOUR TV

## STEP 6. MAKE SURROUND SOUND CONNECTIONS TO TV

1. Mount and connect the optional surround sound speakers by following the instructions provided with the speakers.
2. Use the SURROUND option in the AUDIO Menu to adjust the volume of the surround speakers.
3. The level of the surround sound varies relative to the difference between the left- and right-channel stereo signals.

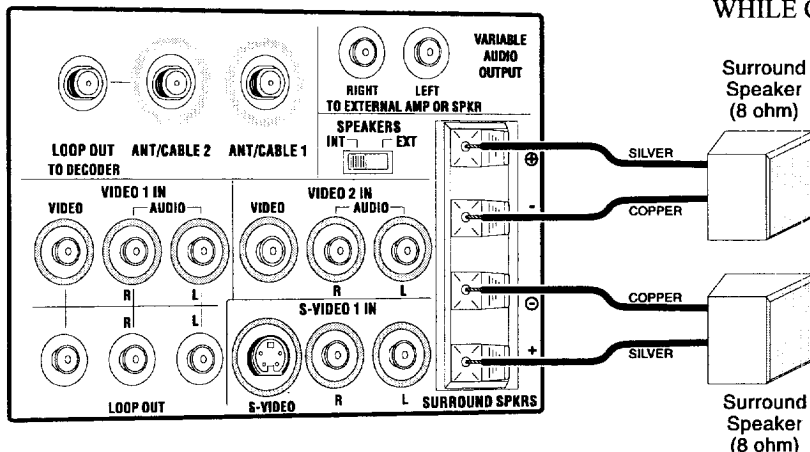

## STEP 7. MAKE EXTERNAL SPEAKER CONNECTIONS TO TV

1. Place the SPEAKERS EXT/INT switch on the TV in the INT position.
2. Connect the two external speaker terminals.
3. Place the SPEAKERS EXT/INT switch on the TV in the EXT position.

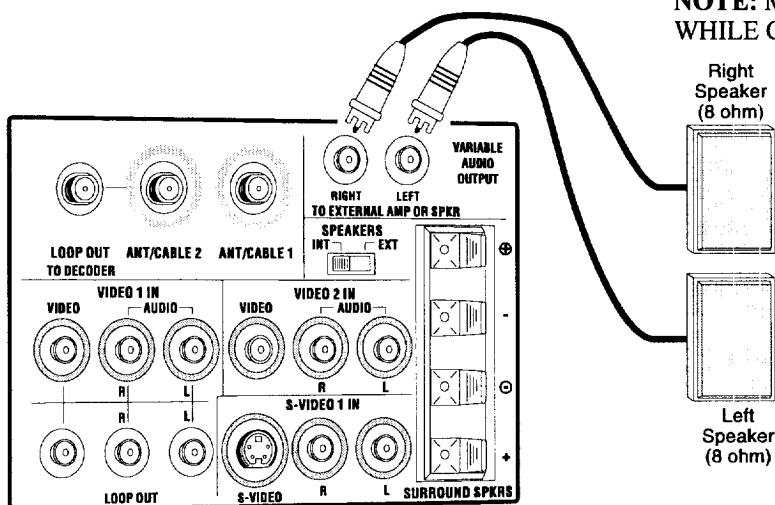

# CONNECTIONS FOR YOUR TV

## STEP 8. MAKE AUDIO CONNECTION TO STEREO AMPLIFIER

Using an External Amplifier with Speakers While the TV's Speakers are OFF.

1. Place the SPEAKERS EXT/INT switch on the TV in the INT position (TV's speakers are ON).
2. Turn the TV ON. Increase the volume level of the TV until the sound just starts to distort (sound bad).
3. Place the SPEAKERS EXT/INT switch on the TV in the EXT position (TV's speakers are OFF).
4. Turn the external audio amplifier ON. Adjust the volume level of the audio amplifier for the highest level you will need for your listening pleasure.
5. Adjust the volume level of the TV for the normal listening level as heard through the speakers of your audio amplifier.

Using an External Amplifier with Speakers While the TV's Speakers are ON.

1. Place the SPEAKERS EXT/INT switch on the TV in the INT position (TV's speakers are ON).
2. Turn the TV ON. Increase the volume level of the TV until the sound just starts to distort (sound bad).
3. Turn the external audio amplifier ON. Adjust the volume level of the audio amplifier for the highest level you will need for your listening pleasure.
4. Adjust the volume level of the TV for the normal listening level as heard through the speakers of the TV.

**NOTE:** If the volume of the internal TV speakers is set too low, you may hear undesirable noises through the speakers connected to your audio amplifier.

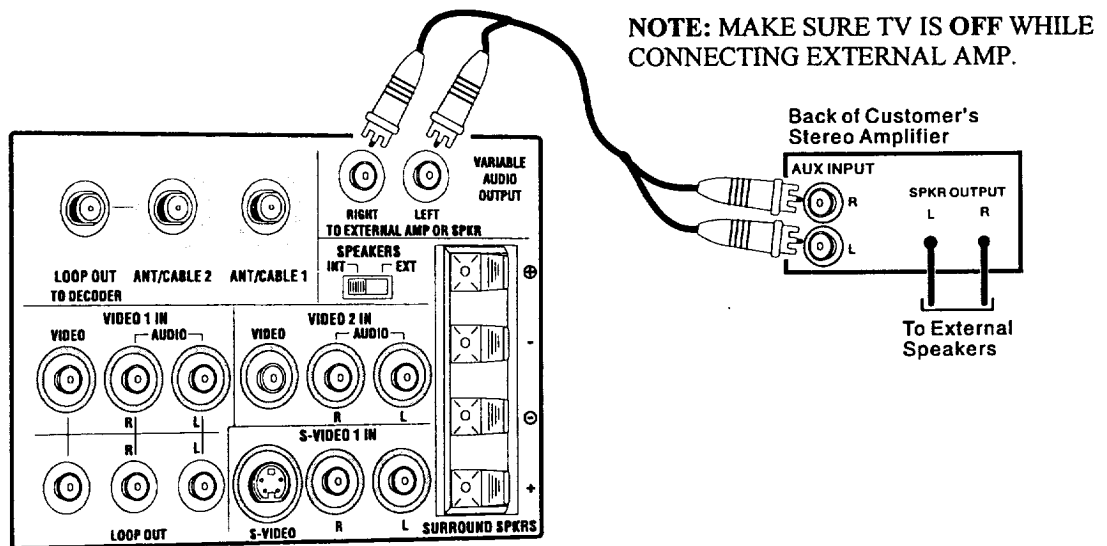

# THE FIRST TIME YOU OPERATE YOUR TV

## STEP 1. CONNECT THE POWER

- A. Plug your TV into an unswitched AC power source.
- B. Turn the TV ON by pressing OFF-ON.

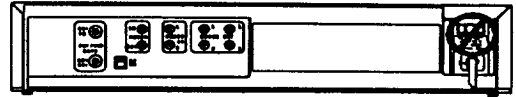

Do not plug TV into switched outlet  
on cable-TV decoder or VCR

## STEP 2. SELECT YOUR VIEWING SOURCE

A TV source refers to the equipment connected to the TV that supplies the picture and sound to your TV. You select the viewing source by using the SOURCE MENU.

### To Access SOURCE MENU

1. Press SOURCE on the remote control to view the SOURCE MENU.
2. Press SOURCE repeatedly until the desired source is highlighted.
3. Press ENTER to return to normal viewing.



ANT/CABLE 1  
ANT/CABLE 2  
VIDEO 1  
VIDEO 2  
S-VIDEO 1  
VIDEO 3  
S-VIDEO 2

**NOTE:** The antenna or cable must be connected to the TV before using AUTO PROGRAM to find available channels

## STEP 3. USE AUTO PROGRAM

AUTO PROGRAM finds all available channels and stores them in the memory of the TV for use by CHANNEL (CH) Up/Down. Use AUTO PROGRAM only when you first install your TV, or when you permanently change the connections to the TV. For example, when you replace the antenna with a cable-TV system.

**NOTE:** AUTO PROGRAM can only be used with ANT/CABLE 1 or 2 Source selection.

### To Use AUTO PROGRAM

1. Press MENU on your remote control repeatedly until the SETUP MENU appears.
2. Press SELECT (SEL) UP/DOWN to highlight Auto Program.
3. Press ADJUST (ADJ) Left/Right to start Auto Program.
4. Use AUTO PROGRAM independently for each ANTENNA or CABLE signal source connected to your TV. Select one source by using the SOURCE MENU (ANT/CABLE 1 or 2) and use AUTO PROGRAM. When completed, select the other source and use AUTO PROGRAM again.

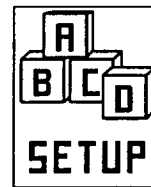

AUTO PROGRAM  
CH. ADD/DEL  
CH. LABELS  
TUNING BAND  
AUTO TUNING  
SOURCE ID  
CLOCK SET  
CAPTIONS

### When Some Channels Are Not Found

AUTO PROGRAM finds only active channels and stores them in the favorite channel memory. You can add channels to those stored in memory by using CH. ADD/DEL.

## STEP 4. TIME FUNCTIONS

### Set Clock In TV

1. Press Menu until the SETUP MENU is selected.
2. Press SELECT (SEL) to highlight CLOCK SET then use the number buttons on the remote to enter the correct time.
3. Select AM or PM using the TIMER key on the remote.
4. Press ENTER (ENT) to start the clock.

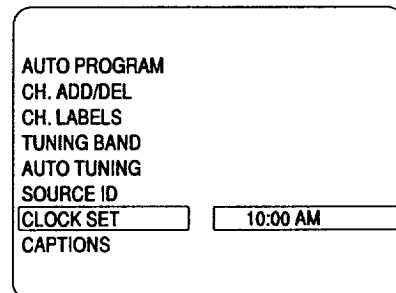

Selecting Clock Set

(continued on next page)

---

# THE FIRST TIME YOU OPERATE YOUR TV

---

## To Use Sleep Timer

1. Press **TIMER** to view the **SLEEP TIMER** screen.
2. Press **TIMER** repeatedly until you reach desired shut-off time.

One minute before the TV shuts off, the **GOOD NIGHT** display appears on the screen. At this time you have a choice of the following three actions.

1. Do nothing. The TV will shut off in one minute. The display will count off the remaining seconds.
2. Remove the **GOOD NIGHT** display by pressing **ENTER**. The TV will still shut off in one minute.
3. Delay the shut off by pressing **TIMER** to select a new shut-off time.

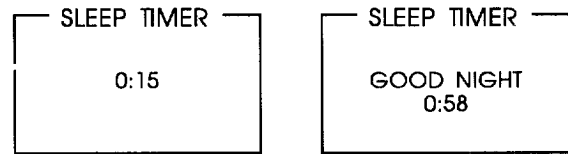

## To Cancel the SLEEP TIMER

You can cancel the **SLEEP TIMER** by setting the **SLEEP TIMER** status to **OFF**.

**NOTE:** The **SLEEP TIMER** resets to **OFF** when you turn off the TV.

## To Use ON/OFF Timer

1. Press **TIMER** and then **MENU** on the remote to view the **ON/OFF TIMER** screen.
2. Press **SELECT (SEL)** to highlight **ON TIME**. Use the number keys on the remote to enter the time for the TV to turn on. Press **TIMER** to choose **AM** or **PM**.
3. Press **SELECT (SEL)** to highlight **OFF TIME**. Use the number keys on the remote to enter the time for the TV to turn off. Press **TIMER** to choose **AM** or **PM**.

4. Press **SELECT (SEL)** to highlight **TIMER**. Use **ADJUST (ADJ)** on the remote to turn **TIMER ON** or **OFF**.

**NOTE:** A time must be set in either the **ON TIME** or **OFF TIME** before you can turn the **TIMER ON**.

5. Press **ENTER (ENT)** to return to normal viewing.

**NOTE:** The **ON/OFF Timer** can not be used until after the television's clock is set.

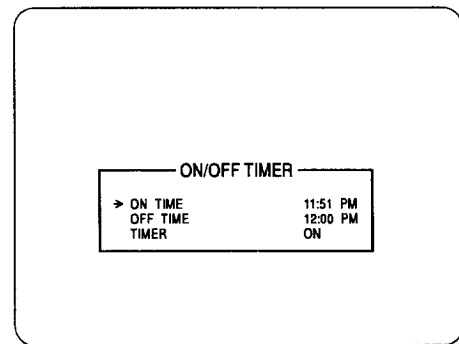

**ON/OFF Timer**

---

## STEP 5. USE OTHER OPTIONS

You may want to use the following options:

- Program the channels accessed when using **CHANNEL Up/Down**. Refer to **CH. ADD/DEL** option for details.
- Add labels (such as **NBC** and **ABC**) to the **Channel/Time** display. Refer to **CH. LABELS** option for details.

# REMOTE CONTROL MODEL SC2400

## OPERATION

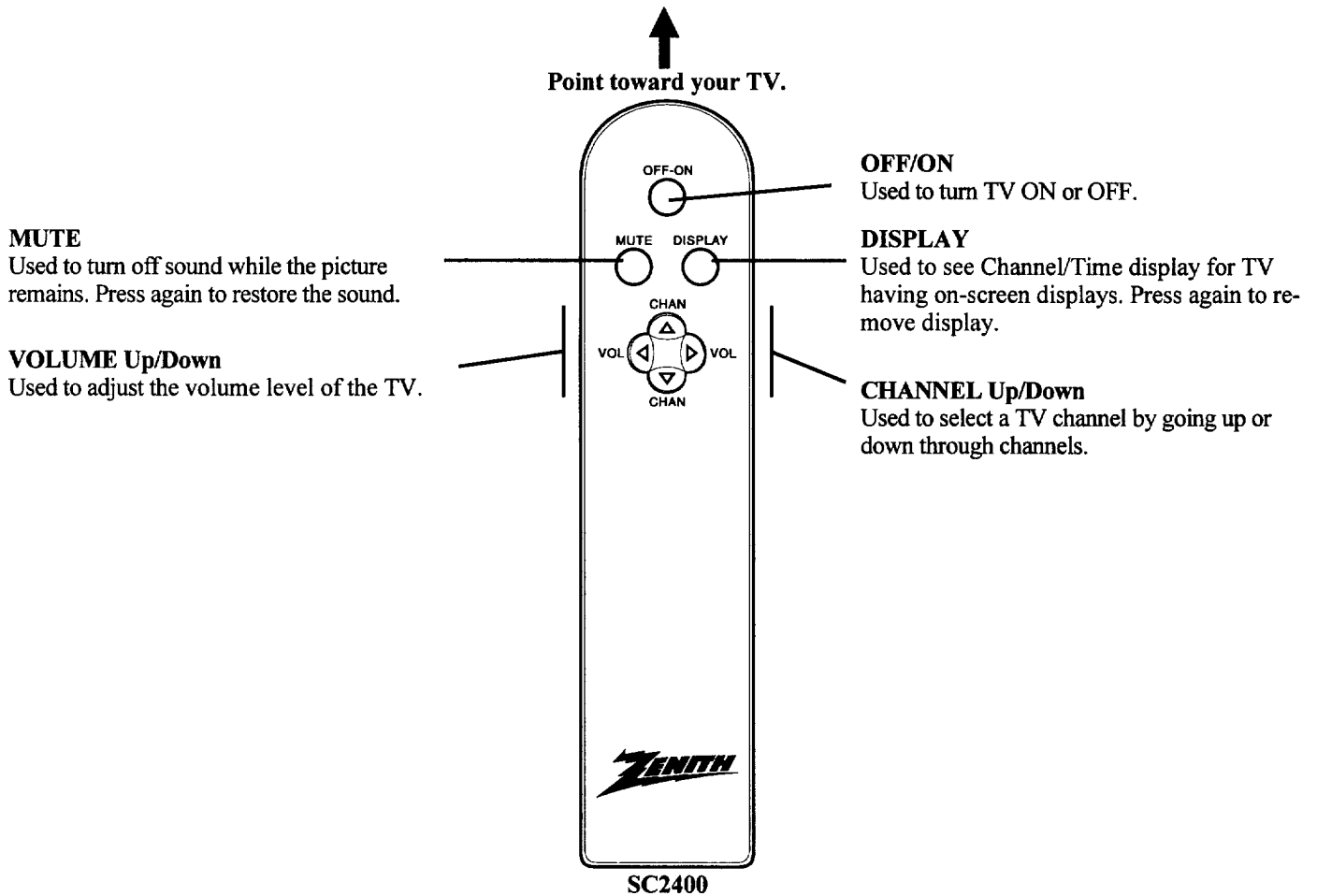

## INSTALLING BATTERIES

When the effective range of the remote becomes noticeably shorter, replace the batteries with two (2) high quality, size AAA, alkaline batteries.

Zenith is not responsible for damage caused by battery leakage.

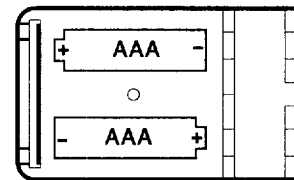
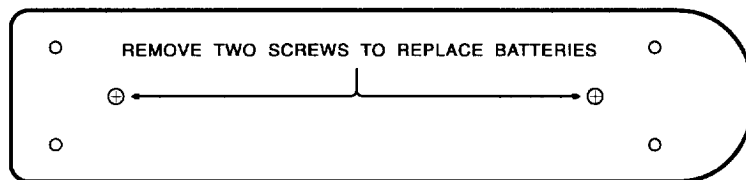

# REMOTE CONTROL MODEL MBR3430

## OPERATION

The multi-brand remote supplied with your new Zenith TV allows you to operate most models of infrared (IR) remote-controlled TVs, VCRs and cable-TV converters, even if they are all different brands.

Your multi-brand remote has already been programmed to operate your Zenith TV, a Zenith VCR and a Zenith cable-TV decoder. It must be "taught" to operate other brands. Refer to "Programming Your Remote Control" for details.

## CHOOSE THE OPERATING MODE

To operate your TV, VCR, CABLE-TV decoder, or an AUX (auxiliary) device, you must first choose the remote's mode of operation. To select the mode, press the MODE key until the desired indicator lights.

Some KEYS on the remote will always operate a particular appliance. For example, VOLUME always operates the TV volume and PLAY always operates the VCR. The function of other keys depends on the mode selected.

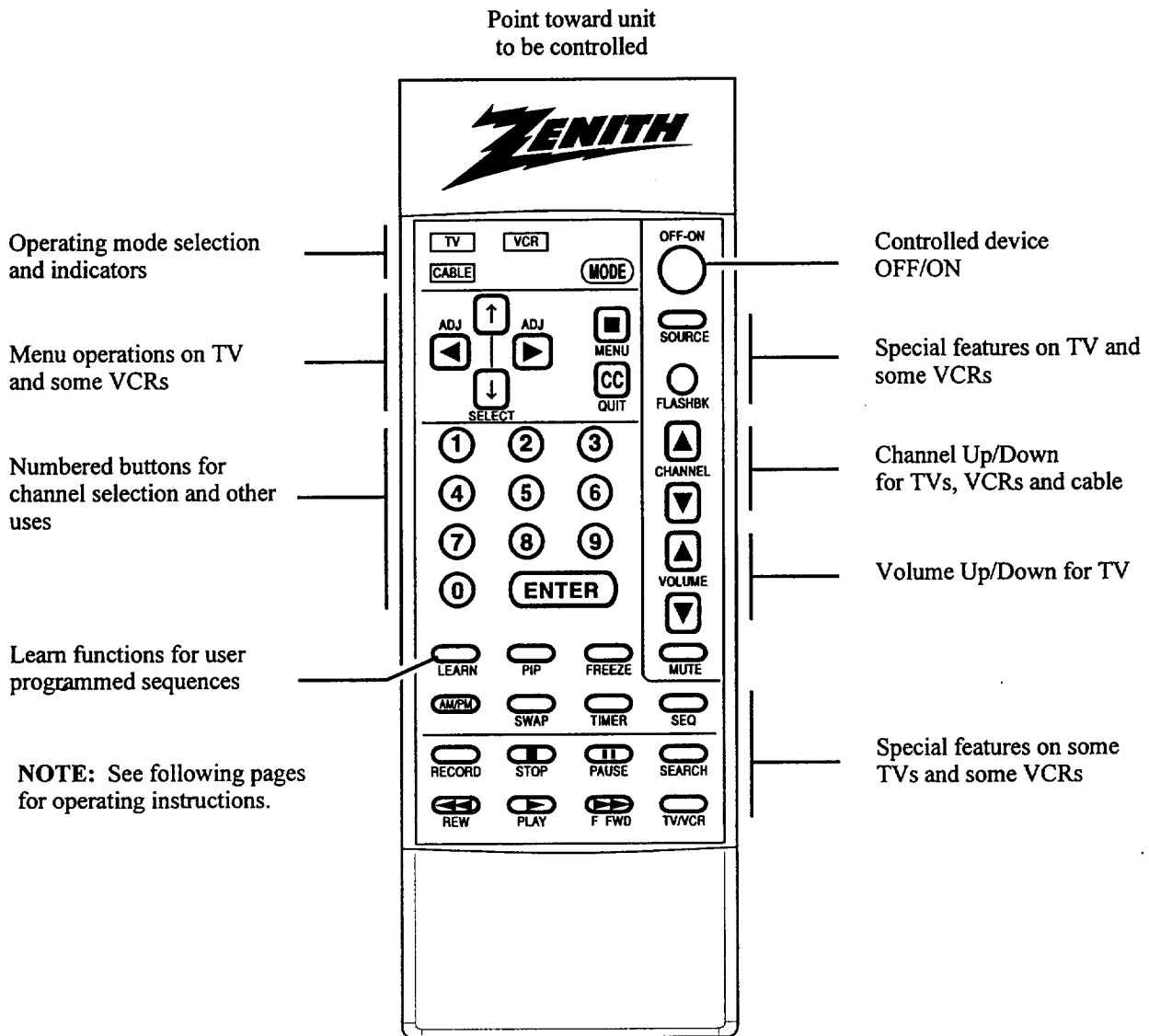

MBR3430

# REMOTE CONTROL MODEL MBR3430

## TV OPERATIONS

The following functions and operations apply to your Zenith TV. The remote control must be in the TV mode to operate your TV.

### MODE

Used to select the TV mode of operation.

### TV

Lights when TV mode of operation is selected.

### CC (Closed Captions)

Used to view closed captions broadcast with some television programs.

### MENU, SELECT and ADJUST

Used with on-screen menus to see menu, select an option, and adjust that option.

### Numbered Buttons

Used to select a TV channel.

### ENTER

Used to view the Channel/Time Display or to remove any on-screen menu or display.

### LEARN

Used to program remote.

### PIP

Used to activate Picture-In-Picture inset.

### SWAP

Used to swap picture in PIP inset with the main television picture.

↑  
Point toward your TV.

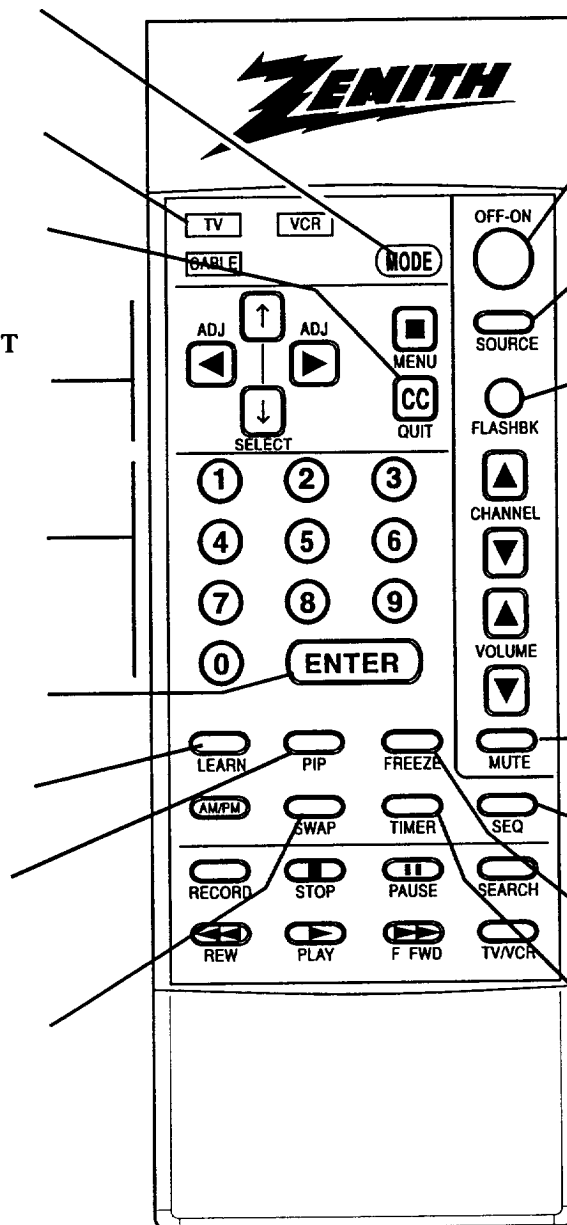

### OFF/ON

Used to turn TV ON or OFF.

### SOURCE

Used to display the menu of TV sources for some TVs. Press again to step through the source selections. On some TVs, press to select AUX (Auxiliary) channel.

### FLASHBK (Flashback)

Used to return to the last TV channel you were watching.

### CHANNEL Up/Down

Used to sequence through the TV channels.

### VOLUME Up/Down

Used to adjust the TV's volume.

### MUTE

Used to turn off sound while the picture remains. Press again to restore the sound.

### SPATIAL EQUALIZATION (SEQ)

Used to select SEQ audio mode on TVs equipped with SEQ feature.

### FREEZE

Used to freeze the motion of the picture on the PIP inset.

### TIMER

Used to activate the SLEEP TIMER. Press repeatedly to select desired turn-off time.

# REMOTE CONTROL MODEL MBR3430

## VCR OPERATIONS

The following functions and operations apply to Zenith VCR models built after 1988. The remote control must be in the VCR mode to operate your VCR.

The remote control supplied with your VCR may have keys not duplicated on the new remote. If these functions are desired, the original remote control will have to be used.

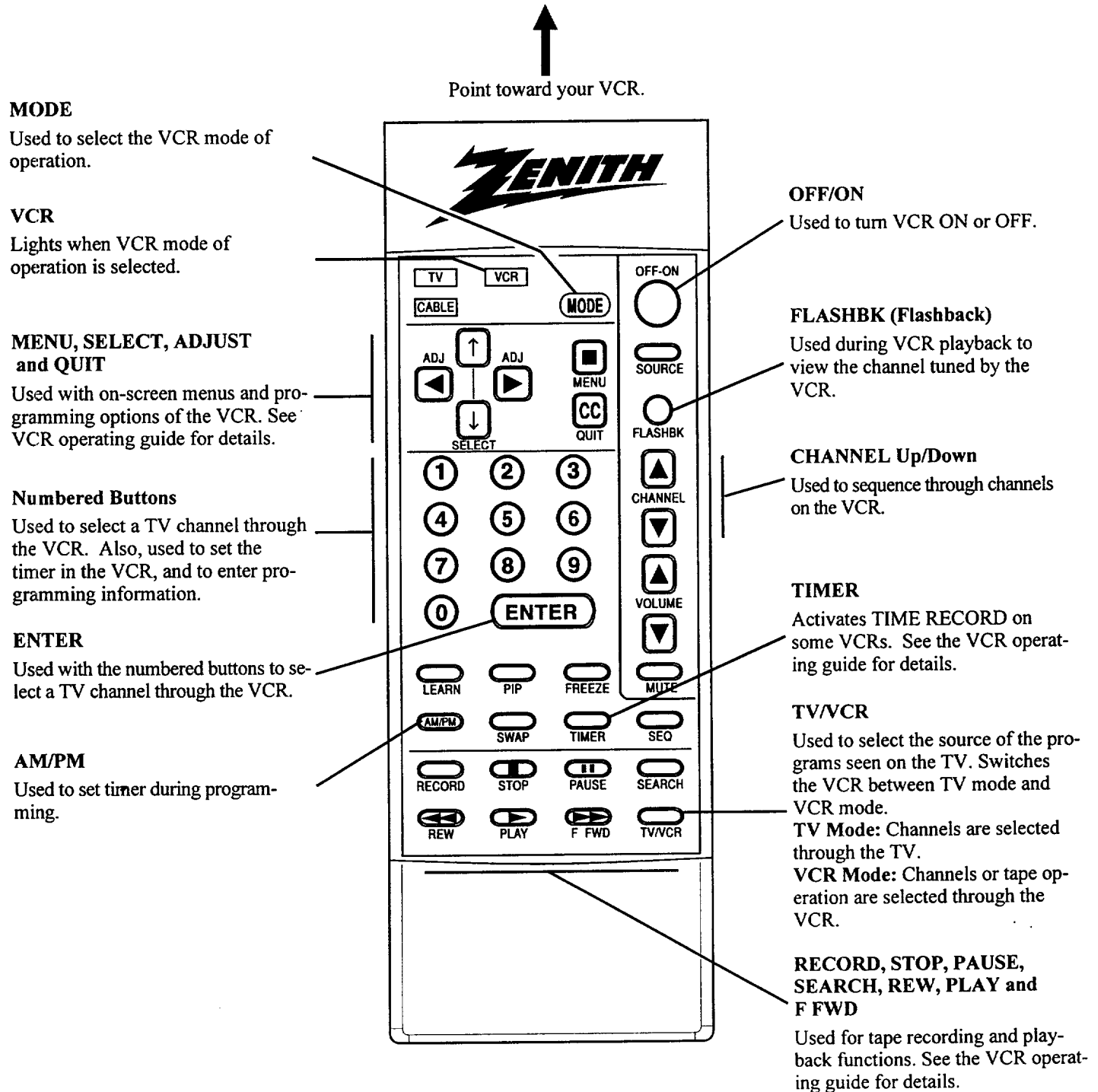



# REMOTE CONTROL MODEL MBR3430

## CABLE-TV OPERATIONS

The following functions and operations apply to a Zenith cable-TV decoder. The remote control must be in the CABLE mode to operate your cable-TV decoder.

The remote control supplied with your cable-TV decoder may have keys not duplicated on the new remote. If these functions are desired, the original remote control will have to be used.

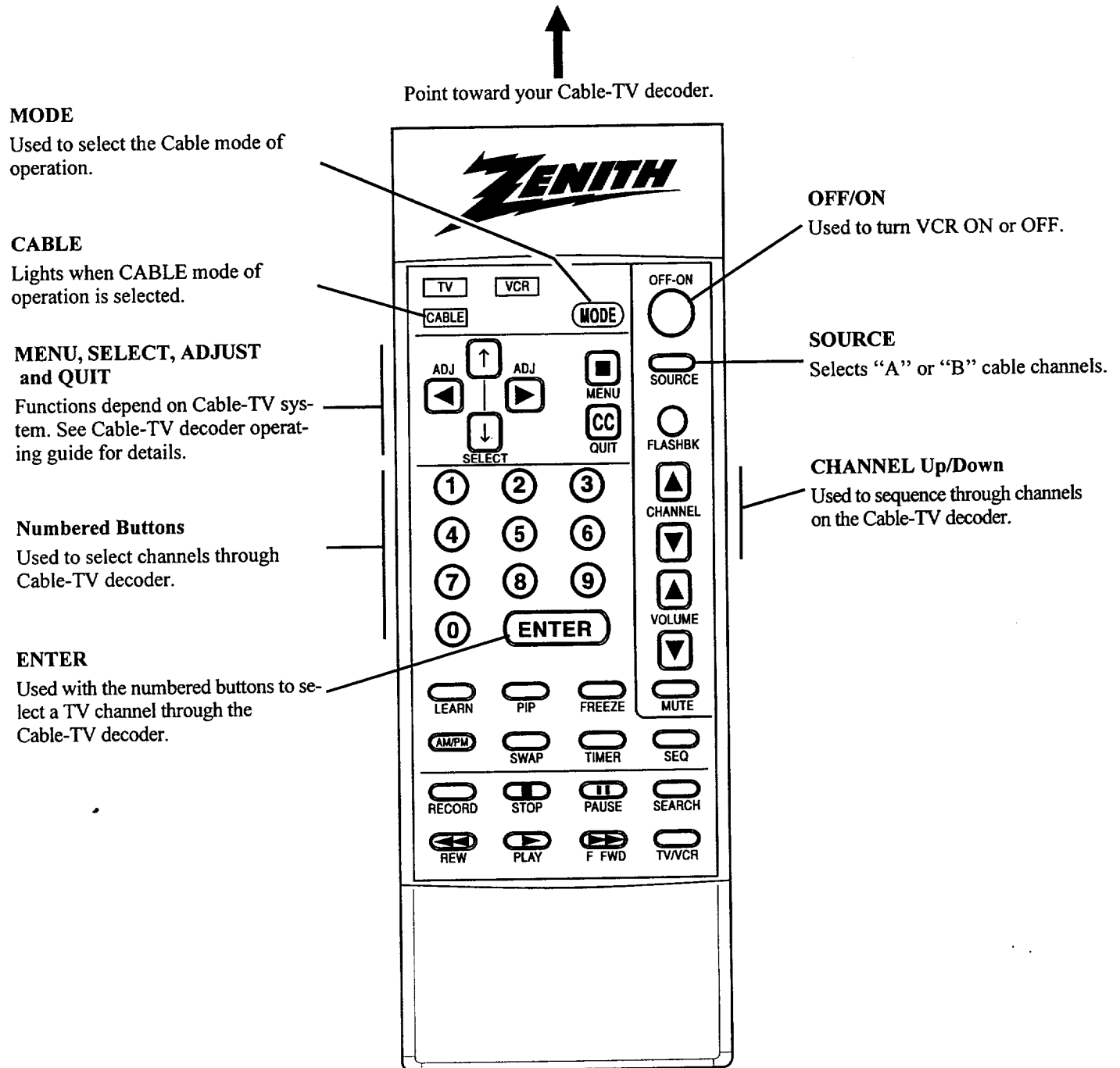

---

# REMOTE CONTROL MODEL MBR3430

---

## PREPARATION FOR USE

Batteries are provided with this remote, but you must install them before using the remote.

---

## INSTALLING BATTERIES

When the effective operating range of your remote becomes noticeably shorter, replace the batteries with two high-quality, alkaline, size AAA batteries.

Zenith is not responsible for damage caused by battery leakage.

After installing new batteries, the remote control will set itself to Zenith brand codes, as follows: TV=101, VCR=201 and CABLE=301.

If you are going to operate equipment that uses different codes, the remote must be reprogrammed for those codes.

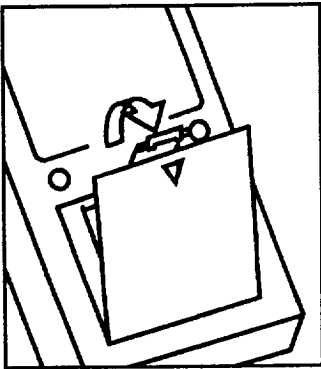

Step 1.

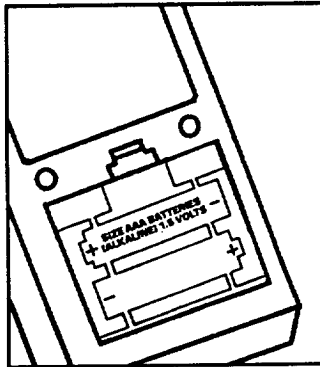

Step 2.

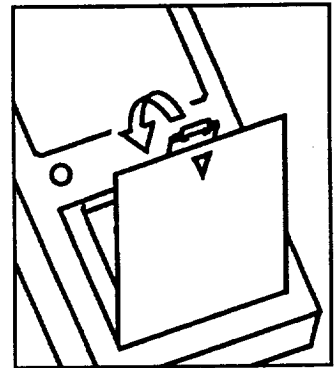

Step 3.

# REMOTE CONTROL MODEL MBR3430

## PROGRAMMING BRAND CODES

### Introduction

Before using your new remote control, it must be programmed to recognize the brands of equipment it will be used to operate. If you are using a Zenith VHS VCR or a Zenith cable-TV decoder, the remote has already been programmed for you.

Find the code that corresponds to each brand and type of equipment you are going to operate. Refer to Tables 1, 2 and 3.

For example, if you were programming the remote for use with a Zenith TV, you would look for "Zenith" in "Table 1", and find code "101."

Write the brand codes for your equipment on the following lines.

TV CODE: \_\_\_\_\_

CABLE CODE: \_\_\_\_\_

VCR CODE: \_\_\_\_\_

1. Press MODE repeatedly to select the desired TV, VCR or CABLE operating mode for the remote.
2. Press LEARN for about 5 seconds until the MODE indicator lights for the selected TV, VCR or CABLE mode of operation.
3. Enter the proper brand code number for the equipment to be controlled.
4. Press LEARN. All three mode indicators should light briefly, then turn off to indicate the brand code has been programmed.
5. If all three mode indicators fail to light briefly, an error has occurred. Repeat Steps 1-4 to try again.
6. Repeat steps 1-4 to program the remote for the other equipment you are using.

**NOTE:** CABLE mode can be programmed to operate a second TV or second VCR, if desired.

When batteries are removed: It will be necessary to reprogram the proper VCR and cable-TV decoder codes.

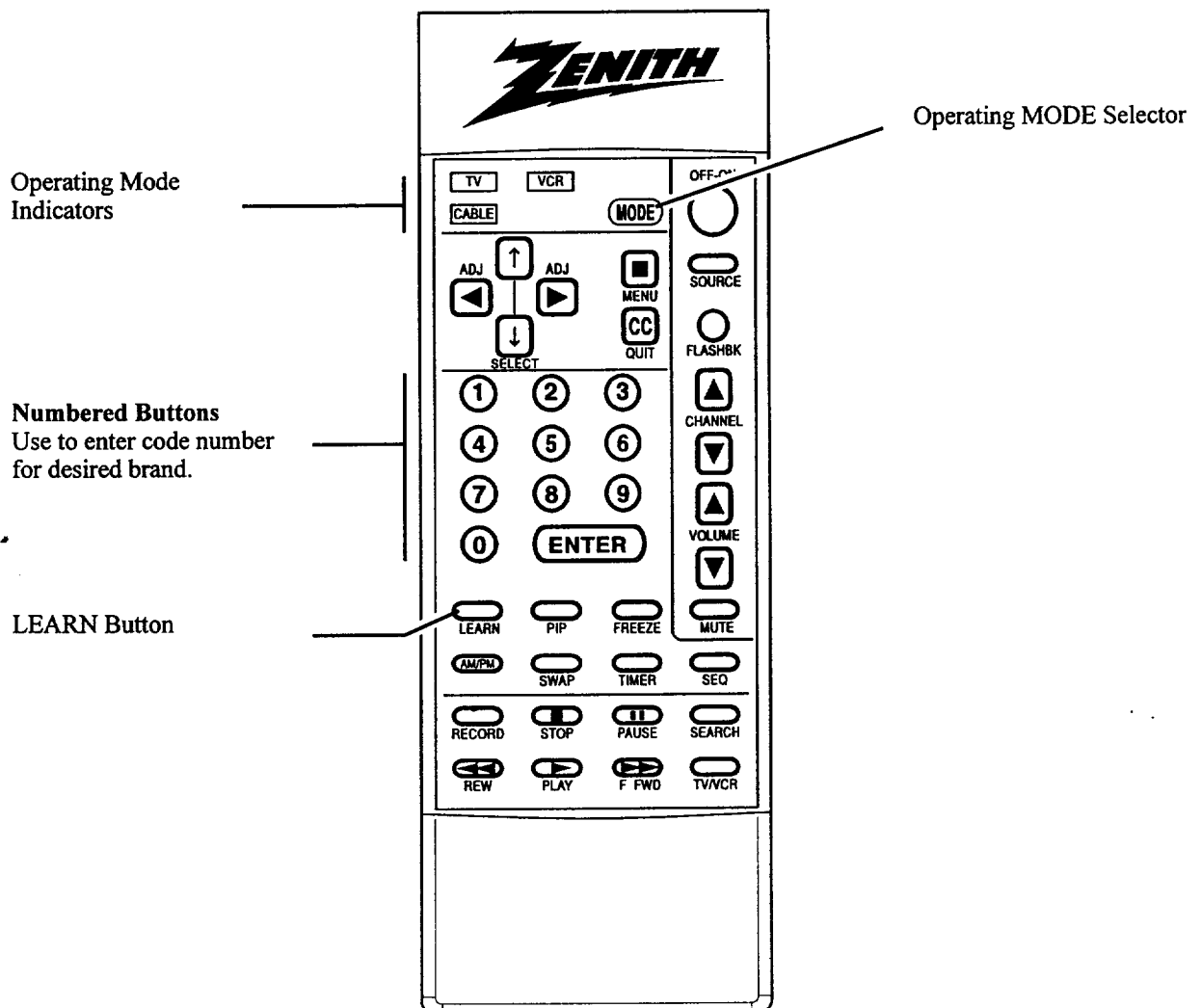

# REMOTE CONTROL MODEL MBR3430

## TV, VCR AND CABLE-TV OPERATING CODES

Table 1. TV Codes by Brand

TV Brand Name	Code	TV Brand Name	Code
Admiral	116	Montgomery Ward	119
Admiral	121	Montgomery Ward	121
Akai	104	Montgomery Ward	130
Amark	103	NEC	104
AOC	104	NEC	119
Bell & Howell	121	Panasonic	106
Centurion	119	Panasonic	107
Coronado	103	Philco	103
Curtis Mathes	116	Philco	104
Curtis Mathes	119	Philco	112
Curtis Mathes	121	Philco	113
Daytron	119	Philips	112
Emerson	103	Philips	113
Emerson	104	Pioneer	135
Emerson	123	Portland	103
Emerson	124	Quasar	106
Emerson	131	Quasar	107
Emerson	136	Realistic	105
Fisher	109	Realistic	123
Fisher	118	Realistic	124
General Electric	106	RCA	104
General Electric	107	RCA	116
General Electric	114	RCA	126
General Electric	116	Sampo	119
Goldstar	103	Samsung	103
Goldstar	104	Samsung	119
Goldstar	119	Samsung	134
Hitachi	102	Sanyo	108
Hitachi	103	Sanyo	109
Hitachi	129	Sanyo	118
JVC	125	Scott	119
JVC	132	Sears	103
J.C. Penney	104	Sears	108
J.C. Penney	110	Sears	109
J.C. Penney	114	Sears	110
J.C. Penney	117	Sears	111
J.C. Penney	119	Sears	118
KMC	103	Sears	134
KTV	103	Sharp	103
KTV	104	Sharp	105
Lodgenet	121	Sharp	122
Logik	121	Sharp	133
LXI	133	Sharp	137
LXI	137	Sony	115
Magnavox	103	Sylvania	112
Magnavox	112	Sylvania	113
Magnavox	113	Sylvania	117
Magnavox	119	Sylvania	119
Magnavox	127	Sylvania	127
Magnavox	128	Sylvania	128
Majestic	121	Tatung	106
Marantz	104	Teknika	103
Marantz	120	Teknika	112
Memorex	121	Teknika	121
MGA/Mitsubishi	104	Teknika	124
MGA/Mitsubishi	119	Telerent	103
MGA/Mitsubishi	120	Telerent	121
MGA/Mitsubishi	130	Toshiba	110
Montgomery Ward	103	Toshiba	111
Montgomery Ward	104	Toshiba	134
Montgomery Ward	105	Yorx	119
Montgomery Ward	113	Zenith	101
Montgomery Ward	114		

Table 2. VCR Codes by Brand

VCR Brand Name	Code	VCR Brand Name	Code
Akai	223	Pentax	215
Audio Dynamics	202	Philco	214
Audio Dynamics	218	Philips	214
Broksonic	221	Philips	227
Canon	214	Pioneer	210
Citizen	209	Pioneer	215
Craig	212	Pioneer Laser Disk	228
Curtis Mathes	214	Quasar	214
Curtis Mathes	216	RCA	215
DBX	202	RCA	216
DBX	218	RCA	220
Emerson	203	RCA	227
Emerson	221	Realistic	206
Emerson	223	Realistic	208
Emerson	226	Realistic	212
Emerson	233	Realistic	214
Emerson	235	Realistic	231
Fisher	211	Samsung	220
Fisher	212	Samsung	230
Fisher	213	Sanyo	206
Funai	231	Sanyo	212
General Electric	214	Scott	204
General Electric	216	Scott	205
General Electric	220	Scott	233
Goldstar	209	Sears	206
Hitachi	215	Sears	209
Instant Replay	214	Sears	211
Instant Replay	227	Sears	212
JVC	202	Sears	215
JVC	225	Sharp	208
J.C. Penney	214	Sony VHS	232
J.C. Penney	218	Sony Video 8	217
J.C. Penney	227	Sylvania	207
Kenwood	202	Sylvania	214
Magnavox	207	Sylvania	227
Magnavox	214	Symphonic	231
Marantz	207	Tashiko	209
Marantz	218	Tatung	202
Marta	209	Teac	202
Memorex	212	Teac	231
Memorex	214	Teknika	234
Memorex	231	Toshiba	205
MGA/Mitsubishi	204	Toshiba	215
MGA/Mitsubishi	222	Vector Research	204
Montgomery Ward	208	Vector Research	218
Montgomery Ward	214	Yamaha	202
Montgomery Ward	219	Yamaha	218
NEC	202	Zenith VHS	201
NEC	218	Zenith VHS	225
Panasonic	214	Zenith VHS	229

Table 3. Cable Decoder Codes by Brand

Cable Decoder Brand Name	Code	Cable Decoder Brand Name	Code
Drake Satellite	312	Pioneer	315
Drake Satellite	330	Regency	329
Gemini	305	Samsung	335
Gemini	331	Scientific Atlanta	316
General Instrument	305	Scientific Atlanta	323
General Instrument	306	Scientific Atlanta	336
Hamlin	302	Sprucer	
Hamlin	303	(Panasonic)	313
Jerrold	304	Standard	
Jerrold	307	Components	335
Jerrold	308	STS Satellite	324
Jerrold	309	Telecaption 4000	325
Jerrold	310	Tocom	317
Kale Vision	335	Tocom VIP	318
Macom	314	Toshiba	322
Macom	321	Toshiba Satellite	319
Macom Satellite	322	Zenith	301
Magnavox	334	Zenith	322
NSC	335	Zenith AV3000	327
Oak	311	Zenith Satellite	312
Oak	332	Zenith Satellite	330
Panasonic	313	Zenith Satellite	328
Panasonic	320	Zenith Laser Disk	326
Paragon (Zenith)	333		

# QUICK REFERENCE TO ON-SCREEN MENUS

## AVAILABLE MENUS

Your TV is icon and menu operated. That is, an icon is selected at the top of the TV screen and a menu of adjustment options appears.



- AUTO PROGRAM**
- CH. ADD/DEL
- CH. LABELS
- TUNING BAND
- AUTO TUNING
- SOURCE ID
- CLOCK SET
- CAPTIONS

Unhighlighted

**Highlighted**  
Menu for highlighted icon appears at left of TV screen.

## SUMMARY OF MENU ITEMS



- ANT/CABLE 1**
- ANT/CABLE 2
- VIDEO 1
- VIDEO 2
- S-VIDEO 1
- VIDEO 3 \*
- S-VIDEO 2 \*

**ANT/CABLE 1 or 2 :** Either of these sources may be used for input from an antenna or a cable-TV line.

**VIDEO 1 or 2 :** Either of these sources may be used for input from a VCR.

**S-VIDEO 1 :** Use this source if a Super-VHS VCR is connected to your TV.

**VIDEO 3 :** Use this source if a camcorder is connected to your TV.

**S-VIDEO 2 :** Use this source if a second Super-VHS VCR is connected to your TV.

\* Some models only.

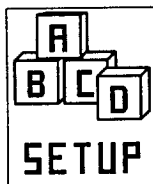

- AUTO PROGRAM**
- CH. ADD/DEL
- CH. LABELS
- TUNING BAND
- AUTO TUNING
- SOURCE ID
- CLOCK SET
- CAPTIONS

**CH. ADD/DEL:** Changes the list of active channels stored in memory so that only your favorite channels are selected when using CHANNEL Up/Down.

**CH. LABELS:** Adds a channel label or name to the channel/time display. For example, ABC may appear when this network channel is tuned.

**TUNING BAND:** Determines the operation of the channel selector inside the TV.

**AUTO TUNING:** Lets your TV compensate for variations in broadcast and cable-TV frequencies.

**SOURCE ID:** Lets you assign a relevant name to each input source.

**CLOCK SET:** Sets the TV's internal clock.

**CAPTIONS:** Displays closed captions (CC) or informational text when available.

**AUTO PROGRAM:** Finds all available channels and stores them in the memory of the TV for use with CHANNEL Up/Down.

---

# QUICK REFERENCE TO ON-SCREEN MENUS

---

## SUMMARY OF MENU ITEMS



**BASS**  
TREBLE  
BALANCE  
AUDIO  
SEQ  
SURROUND

**BASS:** Adjusts the BASS (low-frequency) level.

**TREBLE:** Adjusts the TREBLE (high-frequency) level.

**BALANCE:** Adjusts the BALANCE of sound between the left and right speakers for stereophonic programs.

**AUDIO MODE:** Allows for receiving a Second Audio Program (SAP), such as a program broadcast with two audio portions (typically two languages), or lets you select stereophonic (STEREO) or monaural (MONO) speaker operation.

**SEQ:** Turns on an enhanced stereo mode.

**SURROUND:** Adjusts Surround Sound volume when used with separately supplied Surround Sound speakers.



**CONTRAST**  
BRIGHTNESS  
COLOR  
TINT  
SHARPNESS  
COLOR TEMP  
VIDEO FILTER  
AUTO FLESH  
PICTURE PREF

**CONTRAST:** Adjusts the overall contrast and color level of the picture.

**BRIGHTNESS:** Adjusts the brightness level of black areas in the picture.

**COLOR:** Adjusts the intensity of the colors in the picture.

**TINT:** Adjusts the color of the flesh tones.

**SHARPNESS:** Adjusts the clarity of the edges of objects for the clearest possible picture.

**COLOR TEMP:** Changes the "color temperature" or picture white balance between cooler natural whites and warmer (red) colors.

**VIDEO FILTER:** Reduces video "noise" or interference in dark picture areas resulting in clearer overall pictures.

**AUTO FLESH:** Automatically maintains natural skin tones under changing scene and video source conditions.

**PICTURE PREF:** Lets you decide if you want to use your own CUSTOM video settings, the factory PRESET video settings, or the THEATER video settings for optimum viewing in low-light conditions.

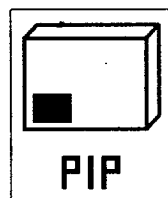

**CH. GUIDE \***  
**CH. REVIEW \***  
PIP SOURCE  
PIP COLOR  
PIP TINT  
PIP SIZE

**CH. GUIDE:** Provides a visual review of all channels in the channel scan memory for the currently selected ANT/CABLE source.

**CH. REVIEW:** Provides a visual review of the last three (3) channels tuned on the TV.

**PIP SOURCE:** Lets you select the equipment that supplies the picture to the PIP inset.

**PIP COLOR:** Adjusts the intensity of the colors in the PIP inset.

**PIP TINT:** Adjusts the color of the flesh tones.

**PIP SIZE:** Lets you choose between seeing a larger or smaller PIP inset.

\* Some models only.

# QUICK REFERENCE TO ON-SCREEN MENUS

## MENU OPERATION EXAMPLE

Press MENU repeatedly until the desired icon is highlighted and its menu is showing. This example shows choosing the SETUP MENU.

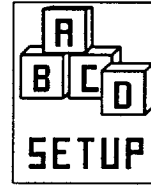
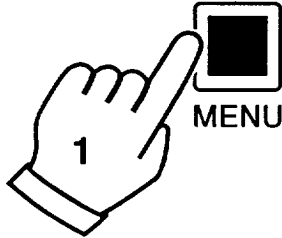

AUTO PROGRAM  
CH. ADD/DEL  
CH. LABELS  
TUNING BAND  
AUTO TUNING  
SOURCE ID  
CLOCK SET  
CAPTIONS

Press SELECT (SEL) Up/Down repeatedly until the desired option/feature is highlighted. This example shows choosing TUNING BAND.

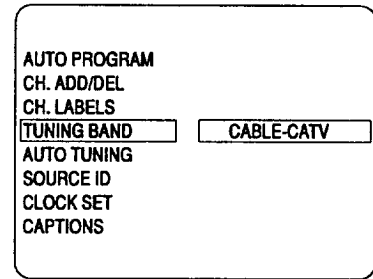
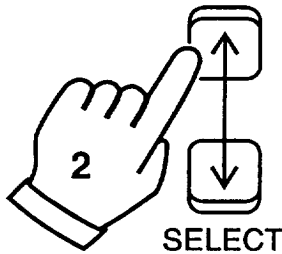

Press ADJUST (ADJ) Left/Right to adjust the option. This example shows the choices you have for TUNING BAND.

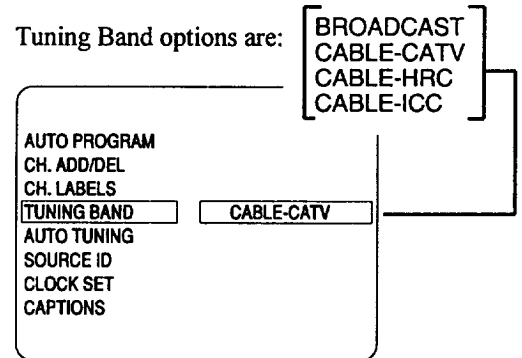
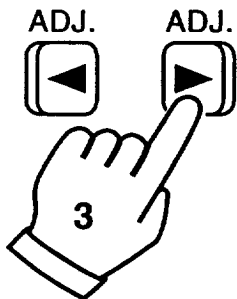

Press ENTER (ENT) or wait a few seconds and the TV will return automatically to normal operation.

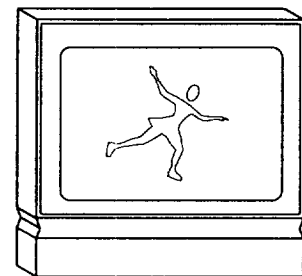
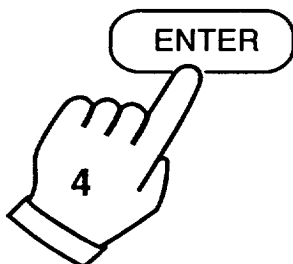

# SOURCE MENU



- ANT/CABLE 1
- ANT/CABLE 2
- VIDEO 1
- VIDEO 2
- S-VIDEO 1
- VIDEO 3 \* Some models only
- S-VIDEO 2 \*

Source Menu

## SOURCE SELECTION

### Purpose

The viewing "source" refers to the equipment that supplies the picture and sound to your TV. You select the viewing source by using the SOURCE MENU.

### To Access the SOURCE MENU

1. Press SOURCE on the remote control to view the Menu icons with SOURCE already selected and its menu showing.
2. Press SOURCE repeatedly until the source you want is highlighted.
3. Press ENTER to return to normal viewing.

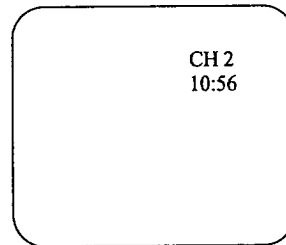

Channel/Time Display For Antenna or Cable Source

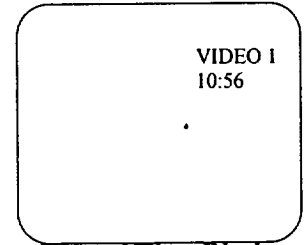

Channel/Time Display For Video or S-Video Source

## SOURCE IDENTIFICATION

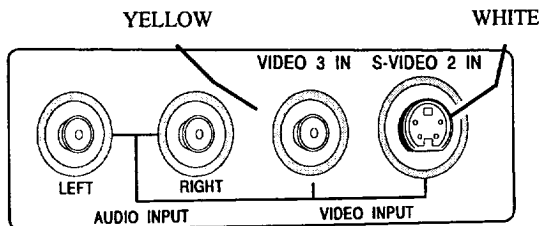

Auxiliary A/V Jacks

**Selecting VIDEO 3 :** Routes the auxiliary video source (such as a camcorder or VCR) to the TV for viewing. The video source must be connected to the corresponding VIDEO 3 jacks.

**Selecting S-VIDEO 2:** Routes the auxiliary Super-VHS VCR source to the TV for viewing. The Super-VHS VCR must be connected to the corresponding S-VIDEO 2 jacks.

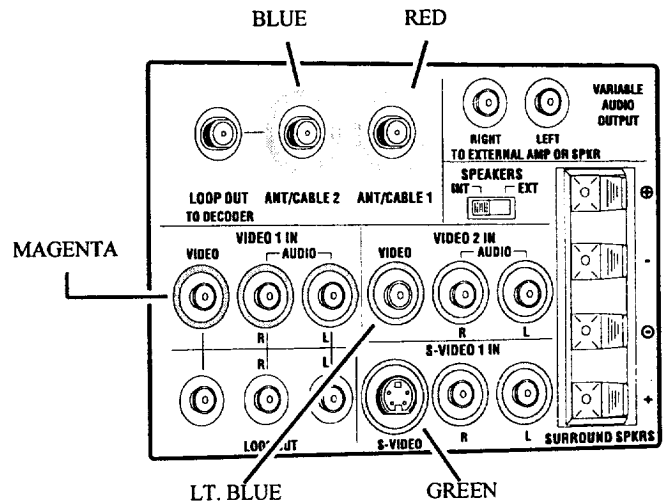

Connection Center on Back of TV

**Selecting ANT/CABLE 1 or 2 :** Routes the ANTENNA or cable-TV source to the TV for viewing. You see program material from whichever signal source is connected to the ANT/CABLE 1 or 2 jack.

**Selecting VIDEO 1 or 2 :** Routes the video source (such as a VCR or a Video Disc player) to the TV for viewing. The video source must be connected to the corresponding VIDEO 1/2 jacks.

**Selecting S-VIDEO 1 :** Routes the auxiliary Super-VHS VCR Source to the TV for viewing. The Super-VHS VCR must be connected to the corresponding input jacks.



# SETUP MENU

## To Access SETUP Menu

Refer to the "Using On-Screen Menus" section for details.

## Before Using SETUP Menu

Connect and turn ON all external equipment, such as cable TV decoder, VCR, etc. before using any item on the SETUP Menu.

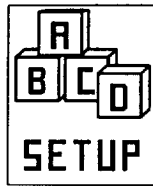

### AUTO PROGRAM

CH. ADD/DEL  
CH. LABELS  
TUNING BAND  
AUTO TUNING  
SOURCE ID  
CLOCK SET  
CAPTIONS

Main Setup Menu

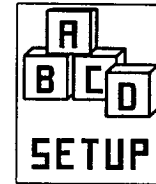

SOURCE ID  
CLOCK SET  
CAPTIONS

Setup Menu for Video  
and S-Video Sources

## AUTO PROGRAM

### Purpose

Finds all available channels and stores them in the memory of the TV for use by CHANNEL (CH) Up/Down.

Use AUTO PROGRAM only when you first install your TV, or when you permanently change the connections to the TV. For example, when you replace the antenna with a cable-TV system.

**NOTE:** AUTO PROGRAM can only be used with ANT/CABLE 1 or 2 Source selection.

### To Use AUTO PROGRAM

1. Press ADJUST (ADJ) Left/Right to start Auto Program.
2. Use AUTO PROGRAM independently for each ANTENNA or CABLE signal source connected to your TV. Select one source by using the SOURCE MENU (ANT/CABLE 1 or 2) and use AUTO PROGRAM. When completed, select the other source and use AUTO PROGRAM again.

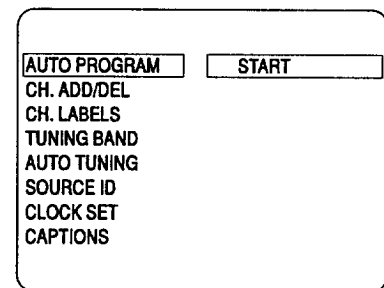

Selecting Auto Program

### When Some Channels Are Not Found

AUTO PROGRAM finds only active channels and stores them in the favorite channel memory. You can add channels to those stored in memory by using CH. ADD/DEL.

## CH. (Channel) ADD/DEL

### Purpose

Lets you add channels to and remove channels from the channel scan. In this way you can customize the channels that are accessed through CHANNEL (CH) Up/Down.

**NOTE:** CH. ADD/DEL can only be used with ANT/CABLE 1 or 2 Source selection.

### To Add a Channel to Scan Sequence

1. Press ADJUST (ADJ) Left/Right to view the channel add/delete screen.
2. Use the number buttons on the remote to enter the channel or use ADJUST (ADJ) Left/Right and SELECT Up/Down to move the highlight to the channel you wish to add.
3. Add the channel by pressing SOURCE until the display shows ADDED.

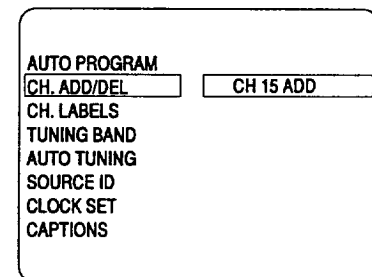

Selecting Ch. Add/Del

### To Delete a Channel from Scan Sequence

1. Press ADJUST (ADJ) Left/Right to view the channel add/delete screen.
2. Use the number buttons on the remote to enter the channel or use ADJUST (ADJ) Left/Right and SELECT Up/Down to move the highlight to the channel you wish to delete.
3. Delete the channel by pressing SOURCE until the display shows DELETED.

(continued on next page)

# SETUP MENU

Available channels for currently selected source.

Available channels are:

BROADCAST Band —  
VHF 2 to 13, UHF 14 to 69

CATV, HRC and ICC Bands —  
1 to 125

Use SELECT Down to move highlight to higher numbers.

Live view of currently selected channel.

Instructions

Channel Status: Added to or Deleted from channel scan.

Currently selected channel.

Channel Add/Delete Screen

## CH. (Channel) LABELS

### Purpose

Assigns a network label or “name” to the selected channels. If you choose the label “ABC” for channel 15, “ABC” appears in the Channel/Time display when channel 15 is selected for viewing.

**NOTE:** CH. LABELS can only be used with ANT/CABLE 1 or 2 Source selection.

A&E	ABC	ACTS	ADC	AMC	BET
BRAV	CA	CBC	CBN	CBS	CMTV
CNBC	CNN	COM	CSPN	CTN	CTV
DIS	DISC	E!	ENC	ESPN	ET
EWTN	FAM	FNN	FOX	GALA	HBO
HN	HSE	HSN	IC	INSP	LIFE
MAX	MEU	MMT	MTV	NBC	NICK
NOS	PBS	PLAY	PTL	QVC	RDS
REQ	SC	SCFI	SHOW	SIN	TBS
TBN	TELE	TLC	TMC	TNN	TNT
TRAV	TSN	TVA	TWN	USA	VC
VCR	VH1	VISN	VJN	WGN	WTBS
WWOR	YTV	-----			

Available Channel Labels

Selecting Ch. Labels

### To Use CH. LABELS

1. Press ADJUST (ADJ) Left/Right to view the channel label screen.
2. Use ADJUST (ADJ) Left/Right and SELECT Up/Down to move the highlight to the LABEL you wish to assign to the current channel.
3. To label another channel, use CHANNEL Up/ Down, or the number keys on the remote control to select the channel number and repeat step 2.
4. To remove an assigned channel label, select the four dashes.

Available channel labels.

Live view of currently selected channel.

Currently selected channel.

Channel Label Screen

# SETUP MENU

## TUNING BAND

### Purpose

Allows for setting the TV channel selector (tuner) to match your antenna or cable-TV system.

If you are having difficulty tuning channels, the TUNING BAND may have to be set manually to match your viewing needs.

**NOTE:** TUNING BAND can only be used with ANT/CABLE 1 or 2 Source selection.

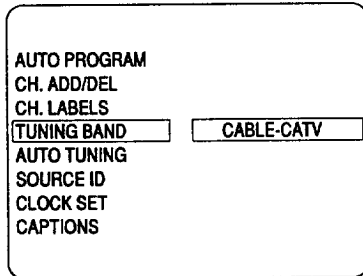

Selecting Tuning Band

### To Use TUNING BAND

Press ADJUST (ADJ) Left/Right to select the tuning band that gives you the most channels:

- BROADCAST — is used for standard “over-the-air” broadcasts.
- CABLE — CATV is used for most standard cable-TV (CATV) systems.
- CABLE — HRC is used for cable-TV systems that use HRC (Harmonically Related Carrier).
- CABLE — ICC is used for cable-TV systems using ICC (Incremental Coherent Carrier).

### Available Channels per Band

The channels that are available in the broadcast and cable tuning bands are shown below:

BROADCAST Band — VHF 2 to 13, UHF 14 to 69

CATV, HRC and ICC Bands — 1 to 125

## AUTO TUNING

### Purpose

Lets your TV compensate for variations in broadcast and cable-TV frequencies.

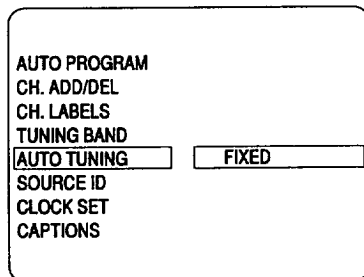

Selecting Auto Tuning

If you are having difficulty tuning channels, the AUTO TUNING may have to be set manually to match your viewing needs.

**NOTE:** AUTO TUNING can only be used with ANT/CABLE 1 or 2 Source selection.

### To Use AUTO TUNING

Press ADJUST (ADJ) Left/Right to select the mode of operation that gives you the most channels:

- FIXED is used to receive “over-the-air” TV stations, and with many cable-TV systems.
- SEARCH is used only when the TV must search to find the frequency being received, such as when used with certain VCRs and video game controllers.

## SOURCE ID

### Purpose

Assigns a descriptive “name” to the input sources. For example, the VIDEO 1 source may be named VCR. “VCR” now appears in the source menu as a reminder that your VCR is connected to VIDEO 1 input jacks.

### To Use SOURCE ID

1. Press ADJUST (ADJ) Left/Right to view the SOURCE ID screen.
2. Use SELECT Up/Down to select a SOURCE.
3. Use ADJUST (ADJ) Left/Right to select the desired name for the source.

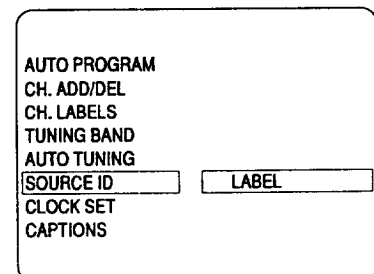

Selecting Source ID

(continued on next page)

# SETUP MENU

## VIDEO GAMES AND OTHER FIXED PATTERN DISPLAY CAUTION

If you use your TV for video games or other fixed displays, avoid setting the BRIGHTNESS control for an excessively bright picture. A bright, fixed pattern, if used for long periods of time, can result in a permanent imprint on the TV picture tube. You can reduce this possibility by alternating the use of the fixed pattern display with normal TV picture viewing, by turning down the CONTRAST control for sustained fixed pattern use, and by turning off the fixed pattern display when not in use.

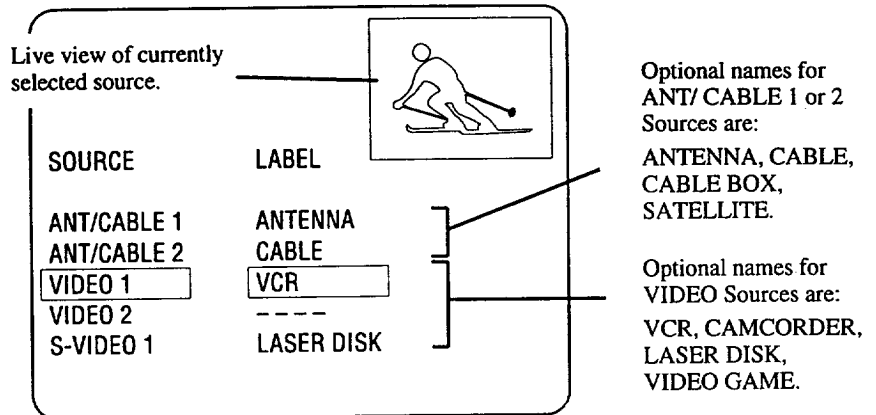

Typical Source ID Screen

## CLOCK SET

### Purpose

Sets the clock in the TV to the correct time.

### To Use CLOCK SET from Remote Control

Use the numbered buttons on the remote control to enter the current time. Press ENTER (ENT) to start the clock. Press TIMER to select AM or PM.

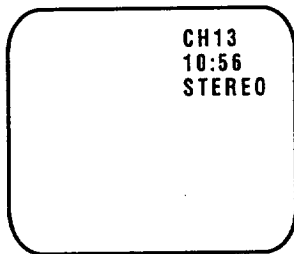

Channel/Time Display On TV Screen

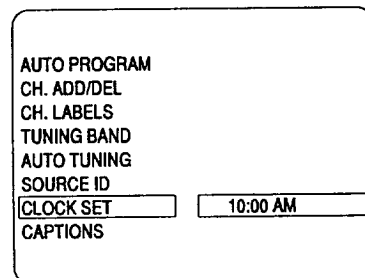

Selecting Clock Set

### To Use CLOCK SET from Control Panel

Use ADJUST (ADJ) Left/Right to set the time. Press ENTER (ENT) to start the clock.

## CAPTIONS

### Purpose

Displays closed captions (CC) or informational text when available on the selected channel.

### To Use CAPTIONS

Press ADJUST (ADJ) Left/Right to select desired mode of operation. Five different selections can be made: OFF, CAPTION 1, CAPTION 2, TEXT 1 or TEXT 2.

At the time this instruction manual was written, little or no information appeared for any selection except CAPTION 1. Therefore you should choose CAPTION 1 and leave it in that selection unless you know there is something available in one of the other options. Once you make a selection, that selection is remembered until you change it.

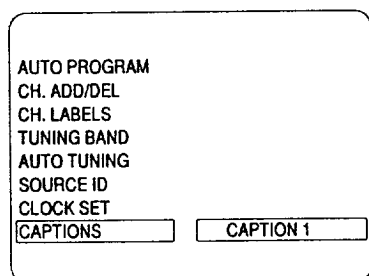

Selecting Captions

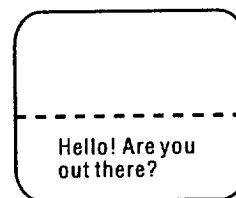

Typical Captions Display

Captions may be shown anywhere on the screen.

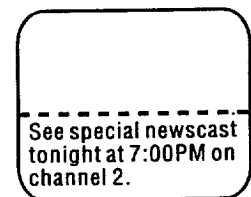

Typical Text Display

Fixed size text window. May be all black when no information is shown.

# AUDIO MENU



- BASS
- TREBLE
- BALANCE
- AUDIO
- SEQ
- SURROUND

BASS	Adjusts the BASS (low-frequency) level.
TREBLE	Adjusts the TREBLE (high-frequency) level.
BALANCE	Adjusts the balance of sound between the left and right speakers for stereo programs.
AUDIO (AUDIO mode options are not available while using a VIDEO or S-VIDEO source. The audio received from these sources are assumed to be stereo.)	<p>Allows you to select STEREO, MONO or 2ND AUDIO/SAP speaker operation.</p> <p><b>STEREO:</b> Directs the sound to the left and right speakers as supplied by the program source (broadcast TV, VCR, etc.)</p> <p><b>MONO:</b> Directs the same sound to both left and right speakers even if the source being received is in stereo.</p> <p><b>2ND AUDIO/SAP:</b> Directs the sound for the Second Audio Program to both the left and right speakers. SAP sound is always monaural. If the SAP signal ends, the audio defaults to either stereo or mono depending on the audio being received.</p>
SEQ (Spatial Equalization)	Improves tonal balance and increases apparent stereo separation to produce a spacious and more tonal sound. SEQ is only available if a stereo signal is being received and STEREO is either selected using the AUDIO option or selected by default.
SURROUND	Adjusts the level of Surround Sound provided to the optional surround sound speakers. Surround Sound is only available if a surround encoded stereo signal is being received and STEREO is either selected using the AUDIO option or selected by default.

## To Access AUDIO MENU

Refer to the "Quick Reference to On-Screen Menus" section for details.

**NOTE:** All adjustments on the AUDIO MENU are optional. You do not have to use these features in order to use your TV.

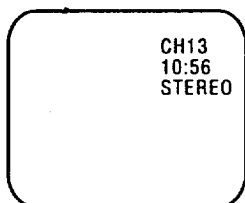

**Audio Mode Shown in Channel/Time Display**

STEREO is selected and a stereo signal is being received. You will hear stereo sound.

## To Adjust BASS, TREBLE, BALANCE and SURROUND

Press ADJUST (ADJ) Left/Right until the most pleasing sound is heard.

## To Use AUDIO Mode Options

Press ADJUST (ADJ) Left/Right to select desired option.

We recommend that you use the STEREO option. The TV will switch automatically between the STEREO and MONO modes dependent on the signal being received.

If you prefer SAP, use the 2ND AUDIO/SAP option. On those stations which broadcast two audio portions, you will hear the SAP (usually a second language). When the SAP broadcast ends, the TV switches automatically between STEREO and MONO modes. The TV switches back to 2ND AUDIO/SAP when the SAP broadcast resumes.

# VIDEO MENU

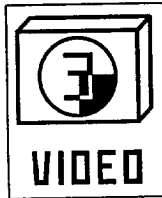

**CONTRAST**  
**BRIGHTNESS**  
**COLOR**  
**TINT**  
**SHARPNESS**  
**COLOR TEMP**  
**VIDEO FILTER**  
**AUTO FLESH**  
**PICTURE PREF**

CONTRAST	Adjusts the overall contrast and color level of the picture.
BRIGHTNESS	Adjusts the brightness level of black areas in the picture.
COLOR	Adjusts the intensity of the colors in the picture.
TINT	Adjusts the color of the flesh tones, where G is Green and R is Red.
SHARPNESS	Adjusts the clarity of the edges of objects for the clearest picture quality.
COLOR TEMP	Changes the "color temperature" or picture white balance between cooler natural whites and warmer (red) colors.
VIDEO FILTER	Reduces video "noise" or interference in dark picture areas resulting in clearer overall pictures.
AUTO FLESH	Automatically maintains natural skin tones under changing scene and video source conditions.
PICTURE PREF. (Preference)	Lets you decide if you want to use your own CUSTOM video settings, the factory PRESET video settings, or the factory preset THEATER video settings for low light conditions.

## To Access VIDEO Menu

Refer to the "Using On-Screen Menus" section for details.

## Optional Adjustments

All adjustments on the VIDEO MENUS are optional. You do not have to use these features in order to use your TV.

## To Use Video Settings

1. Select video option to be adjusted.
2. Press ADJUST (ADJ) Left/Right until the most pleasing picture is seen.

## To Use PICTURE PREF. (Preference)

Press ADJUST (ADJ) Left/Right to select status.

If either the PRESET or THEATER setting is selected, any adjustment made to the VIDEO Menu options automatically changes the PICTURE PREF. setting to custom, and saves your current video settings in the CUSTOM mode.

# PIP MENU

## To Access PIP Menu

Refer to the "Using On-Screen Menus" section for details.

**NOTE:** Selecting the PIP Menu does not "activate" PIP. However, a PIP inset will appear during menu operation to show the effect of any setting changes.

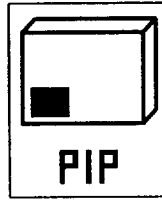

CH. GUIDE \*

Some models only

CH. REVIEW \*

PIP SOURCE

PIP COLOR

PIP TINT

PIP SIZE

## CH. (Channel) GUIDE

### Purpose

Provides a visual review of all channels in the channel scan memory for the currently selected ANT/CABLE source.

### To Use CH. GUIDE

1. Press ADJUST (ADJ) Left/Right to start Ch. Guide.
2. The TV will show small PIP-like views of all channels in the channel scan from the lowest channel number to the highest.
3. Tune to a desired channel by pressing ENTER (ENT) while the picture in the PIP-like inset is active, or enter the channel number using the number keys on the remote.
4. Press MENU to return to the PIP Menu.

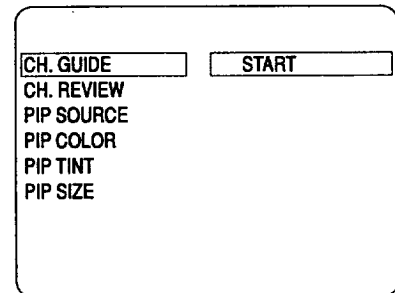

Selecting Ch. Guide

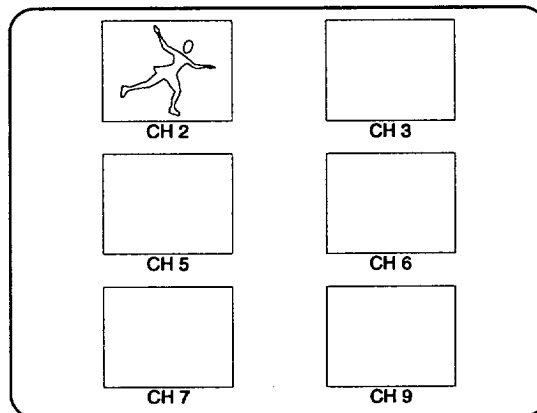

Ch. Guide Screen

---

# PIP MENU

---

## CH. (Channel) REVIEW

### Purpose

Provides a visual review of the last three (3) channels tuned on the TV.

### To Use Ch. Review

1. Press ADJUST (ADJ) Left/Right to start Ch. Review.
2. The TV will show small PIP-like views of the last three channels that were tuned.
3. Tune to a desired channel by pressing ENTER (ENT) while the picture in the PIP-like inset is active, or enter the channel number using the number keys on the remote.
4. Press MENU to return to the PIP Menu.

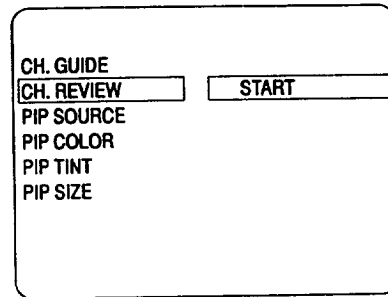

Selecting Ch. Review

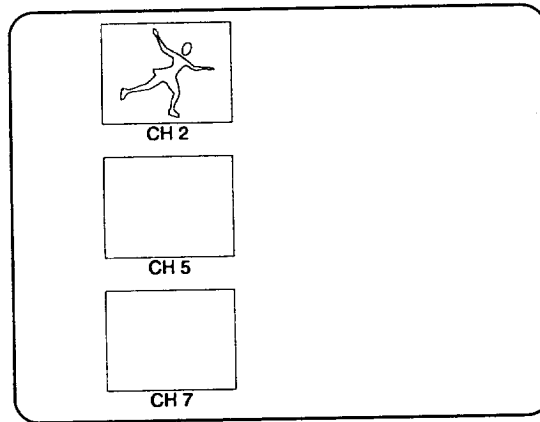

Ch. Review Screen

---

## PIP SOURCE

### Purpose

Lets you select the equipment that supplies the picture to the PIP inset.

### To Use PIP SOURCE

Press ADJUST (ADJ) Left/Right to toggle through your source options.

**NOTE:** If you "named" your sources (see SOURCE ID in the SETUP MENU section), these names will appear when toggling through the PIP SOURCE options.

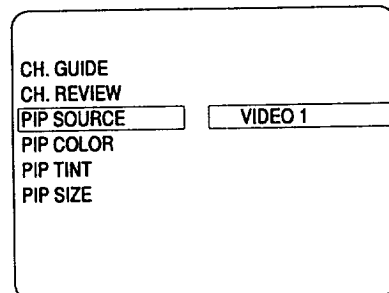

Selecting PIP Source



---

# PIP MENU

---

## PIP COLOR

### Purpose

Adjusts the intensity of the colors in the PIP inset.

To Use PIP COLOR

Press ADJUST (ADJ) Left/Right to decrease or increase the intensity of colors in the PIP inset.

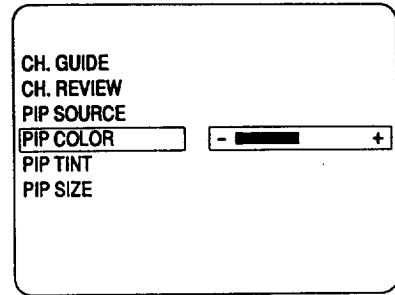

Selecting PIP Color

---

## PIP TINT

### Purpose

Adjusts the color of the flesh tones.

To Use PIP TINT

If flesh tones are too red or purple, press ADJUST (ADJ) Left until you achieve the desired flesh tone.

If flesh tones are too green or have a greenish TINT, press ADJUST (ADJ) Right until you achieve the desired flesh tone.

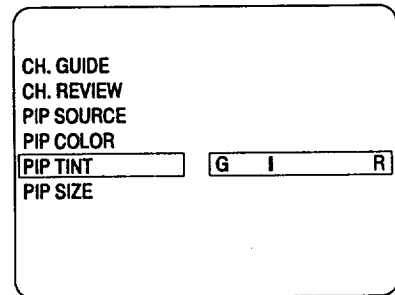

Selecting PIP Tint

---

## PIP SIZE

### Purpose

Lets you choose between seeing a larger or smaller PIP inset.

To Use PIP SIZE

Press ADJUST (ADJ) Left/Right to select either SMALL or LARGE.

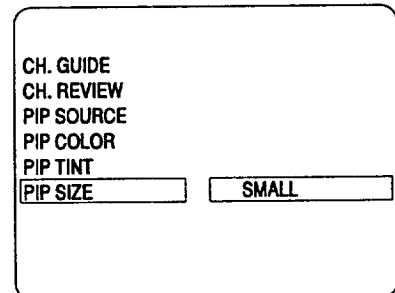

Selecting PIP Size

# PIP OPERATION AND CONNECTIONS

## PIP (PICTURE-IN-PICTURE) OVERVIEW

Your Zenith TV must be connected to a video component such as a VCR in order to view a different picture in the PIP inset. This video component must be connected to one of the TV's video/audio input jacks (VIDEO 1 IN or VIDEO 2 IN) by using Audio/Video cables.

The most common use of PIP is to view two different channels; one from the TV tuner and the other from the VCR tuner. For example, you can view two sporting events or two movies at the same time.

## TYPICAL CONNECTIONS

### Option 1: Antenna or Direct Cable Connection

This illustration shows the basic connection of your TV to a stereo VCR. Using this connection, you are capable of the following operation:

- You may select ANT/CABLE 1 for main picture source to view channels tuned by the TV's channel selector. Simultaneously, you may select VIDEO 1 for PIP source to view — in the PIP inset — a tape playing in the VCR or a different channel tuned by the VCR's channel selector. (VCR's TV/VCR button must be set to TV.)

- Sources may also be swapped. In other words, VIDEO 1 may be the main picture source and ANT/CABLE 1 the PIP source.

### Connection From Antenna or Cable-TV System

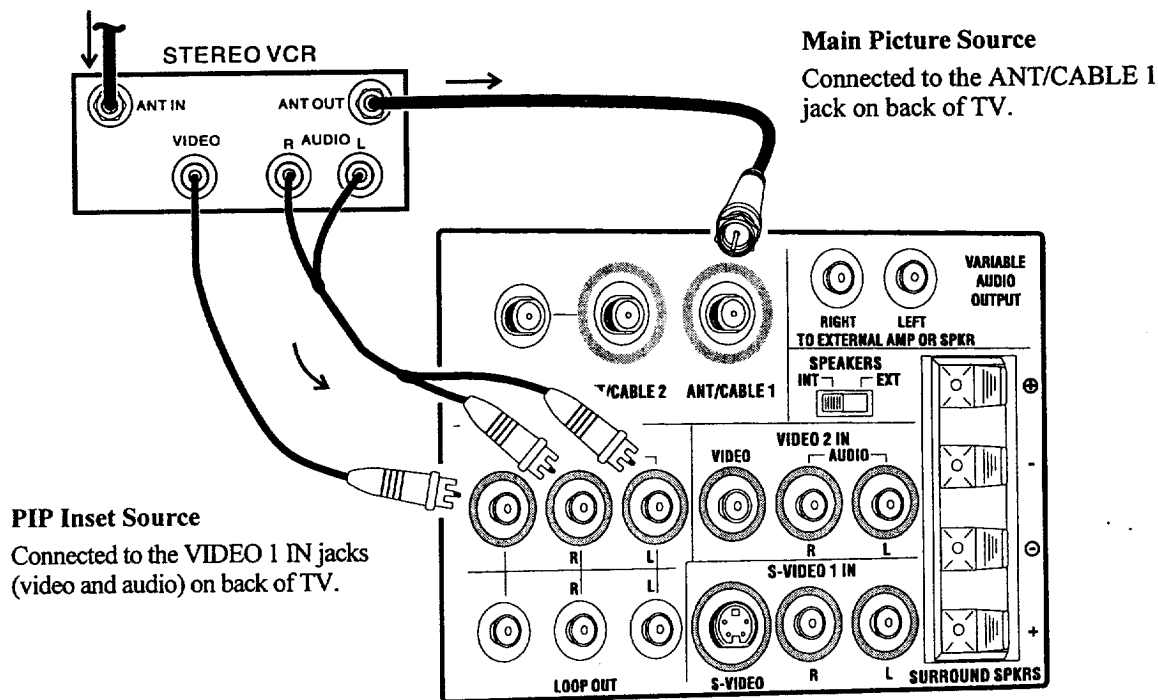

Option 1: Antenna or Direct Cable Connection  
(Optional cables not supplied with television.)

(continued on next page)

# PIP OPERATION AND CONNECTIONS

## Option 2: Antenna or Direct Cable Connection Loop Out

This illustration shows the basic connection of your TV to a stereo VCR. Using this connection, you are capable of the following operation:

- You may select ANT/CABLE 2 for main picture source to view channels tuned by the TV's channel selector. Simultaneously, you may select VIDEO 1 for PIP source to view — in the PIP inset — a tape playing in the VCR or a different channel tuned by the VCR's channel selector. (VCR's TV/VCR button must be set to TV.)

- You may select ANT/CABLE 1 for main picture source to view channels tuned by the TV's channel selector. Simultaneously, you may select VIDEO 1 for PIP source to view — in the PIP inset — a tape playing in the VCR or a different channel tuned by the VCR's channel selector. (VCR's TV/VCR button must be set to TV.)
- Sources may also be swapped: VIDEO 1 may be the main picture and ANT/CABLE 1 the PIP inset.

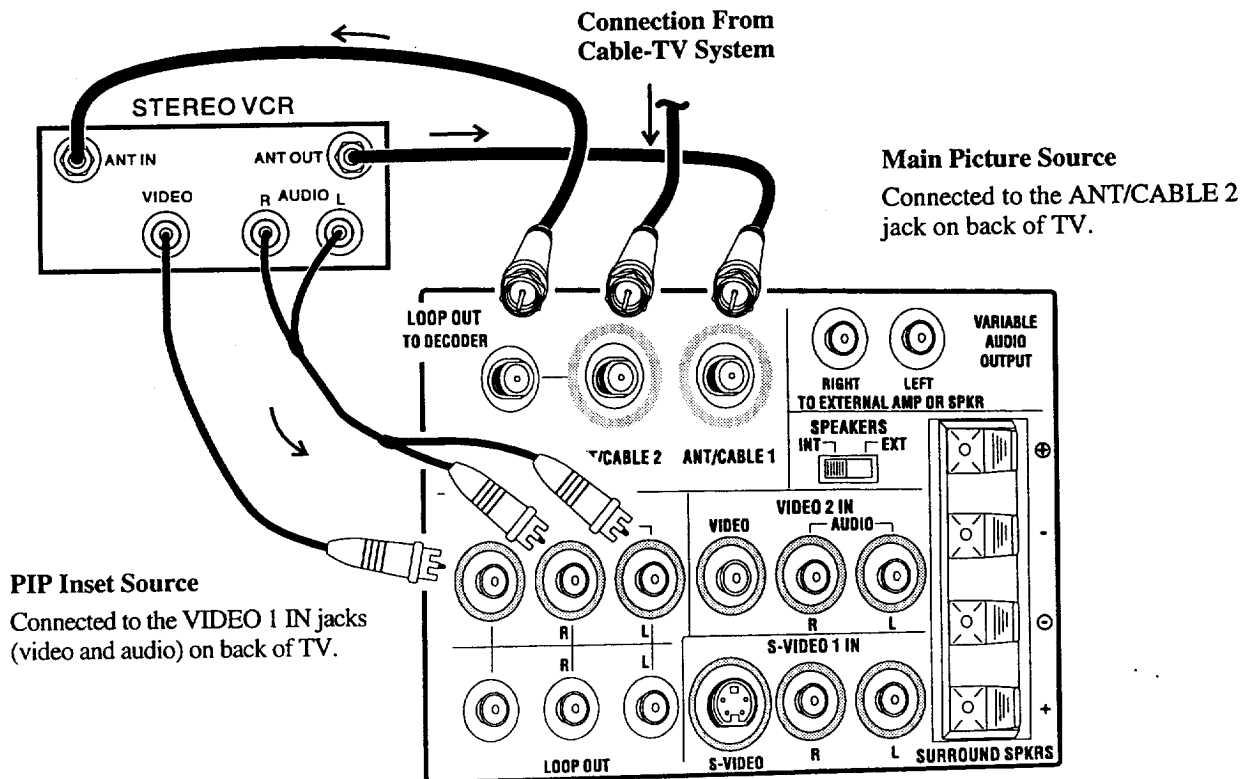

Option 2: Antenna or Direct Cable Connection Loop Out  
(Optional cables not supplied with television.)

(continued on next page)

# PIP OPERATION AND CONNECTIONS

## Option 3: Cable Decoder Connection

This illustration shows the connection of both a cable-TV decoder and a stereo VCR to your TV. Using this connection, you are capable of, but not limited to, the following operation:

- You may select ANT/CABLE 2 for main picture source to view unscrambled cable channels tuned by the TV. Simultaneously, you may select VIDEO 1 for PIP source to view — in the PIP inset — a tape playing in the VCR or a different channel tuned by the cable decoder. (VCR's TV/VCR button set to VCR.)
- You may select ANT/CABLE 1 for main picture source to view premium cable channels tuned by the cable decoder. (Tune TV to channel 3 or 4.) Simultaneously, you may select VIDEO 1 for PIP source to view — in the PIP inset — a tape playing in the VCR. (VCR's TV/VCR button set to TV.)
- Sources may also be swapped. In other words, VIDEO 1 may be the main picture source and ANT/CABLE 1 the PIP inset.

## HOW TO SELECT MAIN PICTURE & PIP SOURCE

In order to watch a different picture in the PIP inset, you must choose a different picture source than the one used for your main TV picture. "Source" refers to the input jacks on the back of your TV set from which the video and audio signals are being received. These jacks correspond to the selections in the SOURCE MENU.

- ANT/CABLE 1 or 2 (Input from antenna, direct cable connection, or cable decoder)
- VIDEO 1, 2 or 3 (Input from VCR or camcorder)
- S-VIDEO 1 or 2 (Input from Super-VHS VCR)

(continued on next page)

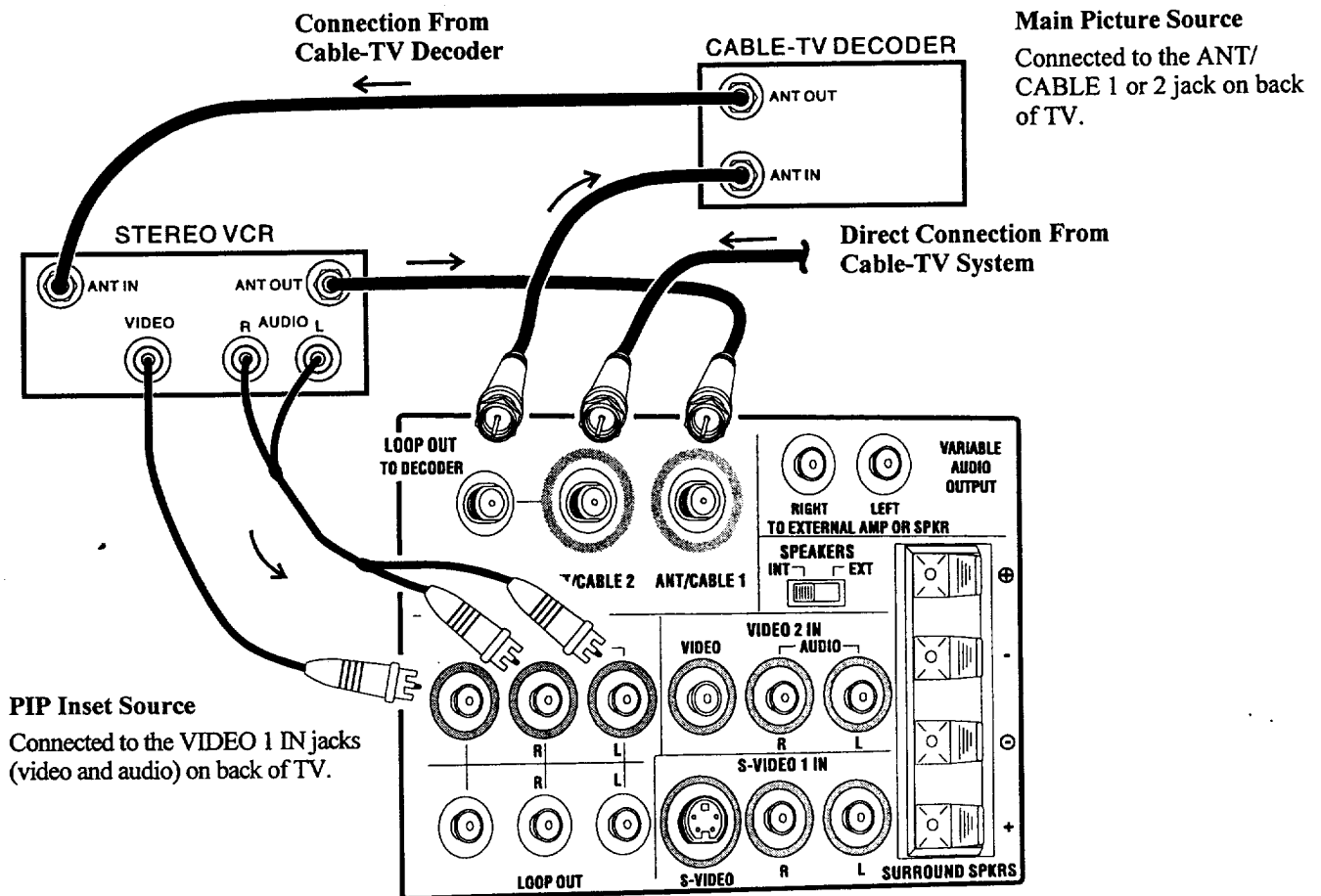

Option 3: Cable Decoder Connection  
(Optional cables not supplied with television.)

# PIP OPERATION AND CONNECTIONS

## To Select Main Picture Source

The source for the main picture can be either ANT/CABLE 1 or 2 connections, or any of the VIDEO connections. The following example selects ANT/CABLE 1 for normal television viewing, which is the most common setup.

1. Select TV mode of operation for the remote control.
2. Press SOURCE on the remote control repeatedly until ANT/CABLE 1 is selected.



- ANT/CABLE 1
- ANT/CABLE 2
- VIDEO 1
- VIDEO 2
- S-VIDEO 1
- VIDEO 3
- S-VIDEO 2

## To Select PIP Source

The PIP inset source can be either ANT/CABLE 1 or 2 connections, or any of the VIDEO connections. The following example selects VIDEO 1 for the PIP source, which is the most common setup.

1. Select TV mode of operation for the remote control.
2. Press MENU on the remote until the PIP Menu is selected.

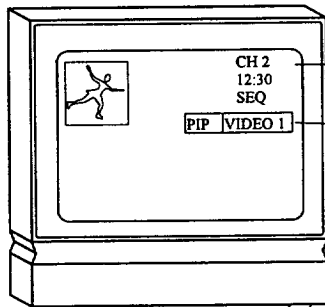

Source of main picture

Source of PIP

3. Use SELECT Up/Down to choose PIP SOURCE then press SOURCE repeatedly to select VIDEO 1.

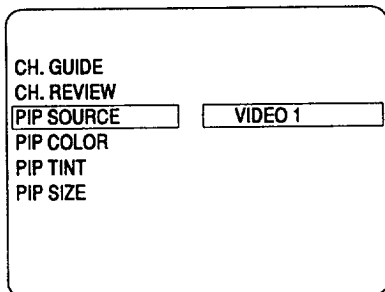

4. Press ENTER to remove menus from the screen.
5. Press PIP on the remote to view the PIP inset.
6. Use the VCR to change the channel in the PIP inset, or to view a tape in the PIP inset.
7. Use ADJUST Left/Right and SELECT Up/Down to position the PIP inset anywhere on the TV screen.

## PIP FUNCTIONS

### PIP

Press PIP to display the PIP inset. Press PIP again to remove inset.

### Moving The Pip Inset Location

Use four-way arrows (ADJ/SELECT) to move PIP inset to the desired location on the TV screen.

### Swap

Press SWAP to swap the main picture with the PIP inset. Press SWAP again to return to the original display.

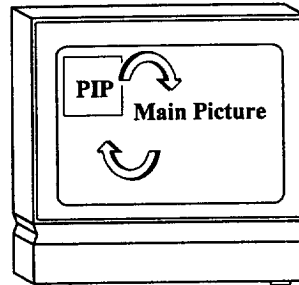

Swap switches the Video from the Main Picture to the PIP inset and the PIP inset to the Main Picture

### PIP Size

Select PIP Size in the PIP Menu to choose between seeing a large or small PIP inset.

### Freeze

Press FREEZE to freeze motion of the picture shown in the PIP inset. Press FREEZE again to return to a live PIP inset.

When the PIP inset is not currently displayed, pressing FREEZE provides an instant PIP freeze-frame of the program you are watching. Press PIP again to return to normal TV viewing. This function can be used without a second source to retain a phone number or freeze a football play.

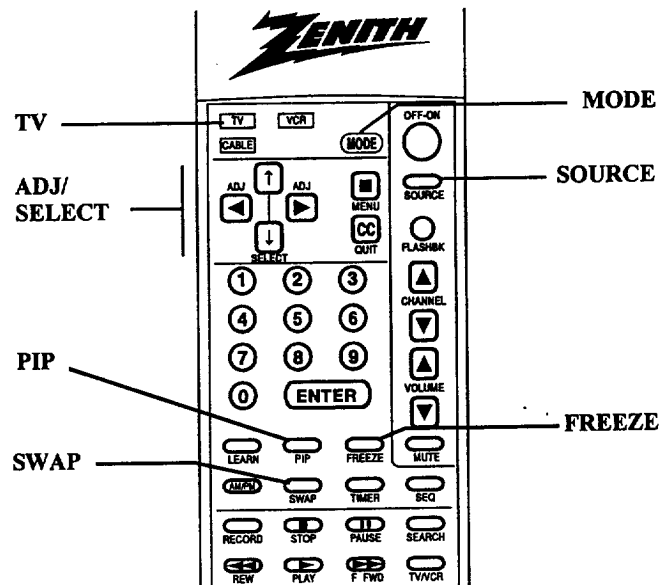

Typical Remote  
Your remote may differ from unit shown.

---

# MAINTENANCE AND TROUBLESHOOTING

---

## CARING FOR YOUR TV

Your TV will look better, have a longer life and perform better if you care for it properly.



First check to see that the TV is off. For added safety, unplug the TV from the power outlet.

**NOTE:** If you unplug your TV, you will have to reset the clock to the current time.

### Picture Glass Cleaning

The picture tube face attracts dust particles and should be cleaned regularly. To clean the face, spray a small amount of glass cleaner on a cleaning cloth and wipe the picture tube glass face until clean. Repeat if necessary.

To delay new dust accumulation, wet a soft cloth in lukewarm water in which a little fabric softener or Ivory dishwashing detergent has been mixed. Wring the cloth almost dry. Wipe the glass face. Make sure no drops of moisture are squeezed onto the glass. Do not wipe the glass dry. Allow the glass to air-dry before you turn the TV on again.

### Cabinet Care

**Non-Wood Cabinet or Cabinet Components.**

Moisten a soft cloth with a mild soap solution or Ivory dishwashing detergent. Wipe the surface with a damp cloth. Then rinse the cloth in clean water and wipe the surface again. Allow the TV to air-dry before turning it on.

**Wood Cabinets or Cabinet Components.**

Use any good furniture cleaner and polish. Regular care will help preserve the finish.

---

## EXTENDED ABSENCE

Before an extended absence (such as a vacation) you may want to unplug the power cord from the electrical wall outlet. This will protect the TV from possible damage from lightning or power line surges. If you have an outdoor antenna, you may also want to disconnect the antenna lead-in wires on the back of the TV.

**NOTE:** If you unplug your TV, you will have to reset the clock to the current time.

---

## TV PICTURE INTERFERENCE

Your TV picture may be affected by interference caused by one or a number of factors. These include:

**Nearby Automobile Ignition, Electrical Appliances, etc.** Which causes a speckled, streaked picture. This is most noticeable in weak signal areas.

**Snow in Picture** Caused by insufficient signal. Usually caused by the TV being located too far from the TV station or by an improper antenna installation.

**Ghosts or Reflections** Caused by signals being reflected from surrounding buildings, water tanks, or other high structures.

**Radio Signal** Police, amateur or CB radio transmitters may cause interference.

These interference problems can often be corrected through the use of a better antenna, signal amplifiers, or various filter devices. See your TV dealer for additional information, and available TV accessories.

# MAINTENANCE AND TROUBLESHOOTING

## BEFORE CALLING FOR SERVICE

Check these items and see if you can correct the trouble by changing the adjustment of a control or the setting of a switch.

By making these simple checks before calling for service, you may save time and money.

### Problem

### Try This

Picture OK. Poor sound.	Re-orient antenna. Try another channel — possible station trouble. Check for local interference. Check AUTO TUNING and TUNING BAND options.
Sound OK. Poor picture.	Re-orient antenna. Try another channel — possible station trouble. Adjust VIDEO Menu options with PICTURE PREF. in CUSTOM mode.
No picture or sound.	Is TV on? Is there power in wall outlet? Is TV plugged in? Is antenna hooked up? Is cable hooked up? Is cable operational? Check auxiliary audio/video equipment. Check channel selection. Check TUNING BAND and AUTO TUNING Menu options.
Picture blurred, ghost in picture, or distorted.	Check antenna or cable hook up for broken wires or loose connection. Try another channel — possible station trouble. Check for local interference.
No color, or poor color.	Try another channel — possible black and white program. Check antenna or cable hook up for broken wires or loose connection. Adjust VIDEO Menu options with PICTURE PREF. in the CUSTOM mode. Is it a color program?
No sound.	VOLUME (VOL) setting may be too low. Check MUTE button operation on remote control, if provided. Is Speaker EXT/INT switch in EXT position?
Cannot select certain channels.	Channels may be skipped in CH. ADD/DEL Menu option. Check TUNING BAND and AUTO TUNING options.
Remote control does not work.	Are batteries okay? Is TV turned ON? Is TV plugged in?
No closed captions.	Are captions available? Is CAPTION 1 or 2 selected by using the CAPTIONS option on the SETUP Menu.
Black or blue box covers one half of the screen.	Is text information available? Is TEXT 1 or 2 selected by using the CAPTIONS option on the SETUP Menu?
No picture or sound when VCR source is selected.	Is VCR hooked up properly? Are wires connected to VCR-VIDEO 1/2 jacks on connection center?
No sound or weak stereo sound when using a stereo VCR.	Check AUDIO mode? Is it STEREO? Was stereo present before selecting VIDEO 1/2 or S-VIDEO Source?
PIP is black when using VCR for PIP source.	Is VCR hooked up properly? Are wires connected to the VIDEO 1/2 input jacks on connection center? Is VCR selected for PIP source?
PIP lacks contrast when using VCR for PIP source.	Is VCR hooked up properly? Are wires connected to the VIDEO 1/2 input jacks on connection center?
PIP inset frame is snowy when using TV tuner for PIP and VCR for main picture.	Is TV/VCR switch on VCR in the TV position?

Always request that your technician use only genuine Zenith exact replacement parts for continued quality and safety performance. Keep your Zenith ALL Zenith.

**NOTE:** If your TV fails to respond to any other menu selection, you must reset the TV. Simply disconnect the AC power. Wait a few minutes, then reconnect the AC power.

# PRODUCT REGISTRATION CARD

## You could win a full refund on your new Zenith product.

Look for the Product Registration Card on your new video product.

Each month a drawing is held by Zenith from the completed Product Registration Cards received during the preceding month. Zenith will reimburse the winner for the full purchase price of the product purchased.

In order to participate, simply complete and return the Product Registration Card at once, even if you choose not to complete the information and interests portion of the questionnaire.

## Product Card lost or misplaced?

The Product Registration Card furnished with your video product is pre-printed with its Model and Serial numbers. Please fill out the card and mail it at your earliest convenience. It is imperative that Zenith know how to reach you promptly if we discover a safety problem that would affect you. If the original card has been lost or misplaced, you may use the replacement card provided below. Either card will qualify you for the free drawing, but you are limited to only one entry in the drawing. Complete the card, place it in an envelope and mail it to:

**Zenith Electronics Corporation**  
 P. O. Box 173257  
 Denver, CO 80217-3257

Use the replacement Product Registration Card only if the original card has been misplaced or lost.

The odds of winning the free drawing described above, depend on the number of participants. Free drawing offer is void in Canada and other places where restricted or prohibited by law. Offer is void for Hotel/Motel and Institutional models. Rental models are not eligible.

PHOTOCOPY AND CUT ALONG DASHED LINE

## Zenith Product Registration Card

**H5Z01-01**

① Please Print Clearly or Type

② Area Code Telephone

1.  Mr. 2.  Mrs. 3.  Ms. 4.  Miss.    -

First Name Initial Last Name

Street Apt. No.

City

③ Date of Purchase

State Zip Code Mo. Day Yr.  
  -

<b>MODEL NUMBER</b>	
<b>Copy Numbers Here From Label on Set</b>	
<b>SERIAL NUMBER</b>	

← Please record the model number and serial number from the sticker on the back of your set.



# BROKEN OR LOST REMOTE CONTROL?

Makes a great spare remote control too!



For an **Exact Replacement Remote Control** for your new Zenith Television, see your local Zenith Dealer or order direct by calling 1-800-255-6790. To assure the correct remote for your new Zenith, please have your television's model number ready!

## ONLY \$39.95

## OTHER FINE ACCESSORIES FOR YOUR TELEVISION.

### Wireless Speaker System:

- Wireless speakers receive sound from TV, VCR, or Stereo through walls, floors, or outside.
- Creates an instant home entertainment center!
- Speakers are easy to move--"no cord clutter." An attractive addition to any room.
- Works up to 150 feet! **Indoors and outdoors.**



ZEN800 WIRELESS SPEAKER SYSTEM ONLY \$199.95

### Wireless Headphone System:

- Wireless Headphones receive sound from TV, VCR or Stereo through walls, floors or outside.
- Allows freedom of activity while relaxing or working around your home.
- Great for bedroom TV--listen without disturbing others.
- Works up to 150 feet! **Indoors and outdoors.**
- Great for the hearing-impaired.



ZEN901 WIRELESS HEADPHONE SYSTEM ONLY \$99.95

### CV4000 Surround Sound Stereo Speakers:

- A Sound so real...almost as if you were part of the action!
- An ideal addition to any Home Theater system.
- Contemporary black finish complements any room.
- For use with any Surround Sound compatible TV.
- Bookshelf size, can be wall mounted or set on a shelf.

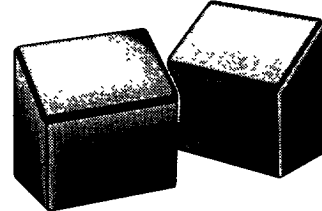

CV4000 STEREO SPEAKERS: ONLY \$99.95

PHOTOCOPY PAGE AND DETACH HERE

To order these fine accessories, please fill out this card and return a photocopy to:

Attn: Accessory Offers  
Zenith Video Tech Corporation  
1000 Milwaukee Avenue  
Glenview, Illinois 60025-2493

or call **1-800-255-6790**

Check or money order  
(Made payable to Zenith Video Tech Corp.)

Visa  Mastercard

Account #

\_\_\_\_\_

Expiration Date: \_\_\_\_\_ Signature: \_\_\_\_\_

**IMPORTANT: PLEASE BE SURE TO COMPLETE THE INFORMATION BELOW.**

TV Model Number (from sticker on back of unit)    TV Serial Number (from sticker on back of unit)    Mo. Day Yr. (Approx. date of purchase.)

PLEASE ALLOW UP TO 3 WEEKS FOR DELIVERY. THANK YOU!

TVACCS4A  
9/8/95

ITEM NUMBER	DESCRIPTION	QUANTITY	PRICE PER ITEM	TOTAL PRICE
Sales Tax: Please add your state sales tax if you live in one of the following states.			<b>SUBTOTAL</b>	
CA 7 3/4%, GA 4%, IL 8 3/4%, KS 4.9%, KY 6%, ME 8%, PA 8%, RI 7%, TX 7 3/4%, VA 4 1/2%, WA 8.2%			<b>STATE SALES TAX</b>	
			<b>SHIPPING &amp; HANDLING</b>	<b>\$4.50</b>
<b>TOTAL AMOUNT OF ORDER</b>				

SHIP TO:

Telephone: ( ) \_\_\_\_\_

Name: \_\_\_\_\_

Address: \_\_\_\_\_

Apt. # \_\_\_\_\_ City \_\_\_\_\_

State \_\_\_\_\_ Zip Code \_\_\_\_\_

NOTE: Orders can only be sent to customers within the United States.

# AVISO PARA NUESTROS CLIENTES DE HABLA HISPANA

Zenith publica muchos de sus manuales de instrucciones en idioma español. Si le interesa pedir la versión en español de este manual, llene el formulario provisto a continuación, fotocópielo y envíelo a la dirección indicada.

No todos los manuales de instrucciones están disponibles en español. Sin embargo, podemos proporcionarle el manual que corresponde a un modelo similar a este, en el cual se describen casi todas las características del producto que usted utiliza.

El manual en español es gratis.

## Instrucciones:

1. Llene el formulario proporcionado a continuación con la información solicitada.
2. Haga una fotocopia del formulario de pedido y envíela a:

Service Literature Department  
**Zenith Video Tech Corporation**  
1000 Milwaukee Avenue  
Glenview, IL 60025-2493

Fotocopie la página y corte la línea punteado

## Formulario de pedido de su manual de instrucciones

206-2846  
M-C8

El producto:

Televisor     Videgrabadora     Otro

Número de modelo \_\_\_\_\_ (lo encontrará en la parte posterior del aparato)

Nombre \_\_\_\_\_

Dirección \_\_\_\_\_ Apartamento \_\_\_\_\_

Ciudad \_\_\_\_\_ Estado \_\_\_\_\_ Código postal \_\_\_\_\_

---

# YOUR ZENITH WARRANTY

---

## Consumer Protection Plan for Zenith TV

Welcome into the Zenith family! We believe that you will be pleased with your new Zenith Color TV. Please read this Consumer Protection Plan carefully. It is a "LIMITED WARRANTY" as defined under Federal Law. This warranty gives you specific legal rights, and you may also have other rights that vary from state to state within the U.S.A.

### Zenith's Responsibility

**Service Labor** — During a period of 90 days from effective warranty date, Zenith will pay for service labor by a Zenith authorized service center when needed as a result of manufacturing defects.

**Parts** — New or remanufactured replacements for factory-defective parts will be supplied by a Zenith authorized service center for one year from effective warranty date (color picture tube — two years). Such replacement parts are warranted for the remaining portion of the original warranty period.

**Home Service** — Warranty service for 19" diagonal (U.S.A.) or larger screen size models is provided in the home in most cases. (Some repairs may require the unit to be taken by the servicer to the repair facility and returned, at no additional charge.)

**Not Covered** — This warranty covers manufacturing defects and does not cover installation, adjustment of customer controls in the home, installation or repair of home antenna systems, cable converters or cable company-supplied equipment; it also does not cover damage due to misuse, abuse, negligence, acts of God or other causes beyond the control of Zenith. Any alteration of the product after manufacture voids this warranty in its entirety.

### Owner's Responsibility

**Effective Warranty Date** — Warranty begins on the date of original consumer installation. For your convenience, keep the dealers dated bill of sale or delivery ticket as evidence of the purchase date.

**Operating Guide** — Read your Operating Guide carefully so that you will understand the operation of your set and how to adjust the customer controls.

**Carry-In Service** — Models under 19" diagonal (U.S.A.) screen size must be taken to a Zenith authorized service center for warranty service and must be picked up by the owner.

**Antenna** — Reception problems caused by inadequate home antennas or faulty antenna connections are the owner's responsibility.

**Important: Product Registration** — Please fill out and mail your Product Registration Card. It is imperative that Zenith know how to reach you promptly if we should discover a safety problem that could affect you.

**Warranty Service** — For warranty service information, contact your Zenith dealer preferably, or any Zenith authorized service center. Parts and service labor that are Zenith's responsibility (see above) will be provided without charge. Other service is at the owner's expense. If you have any problem in obtaining satisfactory warranty service, write:

**Zenith Electronics Corporation**  
Customer Service Department  
1000 Milwaukee Avenue  
Glenview, Illinois 60025-2493  
Telephone: (708) 391-8752  
Mon-Fri, 8:00 a.m. - 4:30 p.m. Central Time

**NOTE:** Before you ask for Warranty service, check the Operating Guide section entitled, "MAINTENANCE AND TROUBLESHOOTING." It may be possible to avoid a service call.

ZENITH ELECTRONICS CORPORATION  
1000 MILWAUKEE AVENUE  
GLENVIEW, ILLINOIS 60025

Part No. 206-2736  
Printed in U.S.A.  
EP-E

---