

Panasonic

Palmcorder IQ™

Camcorder

Operating Instructions

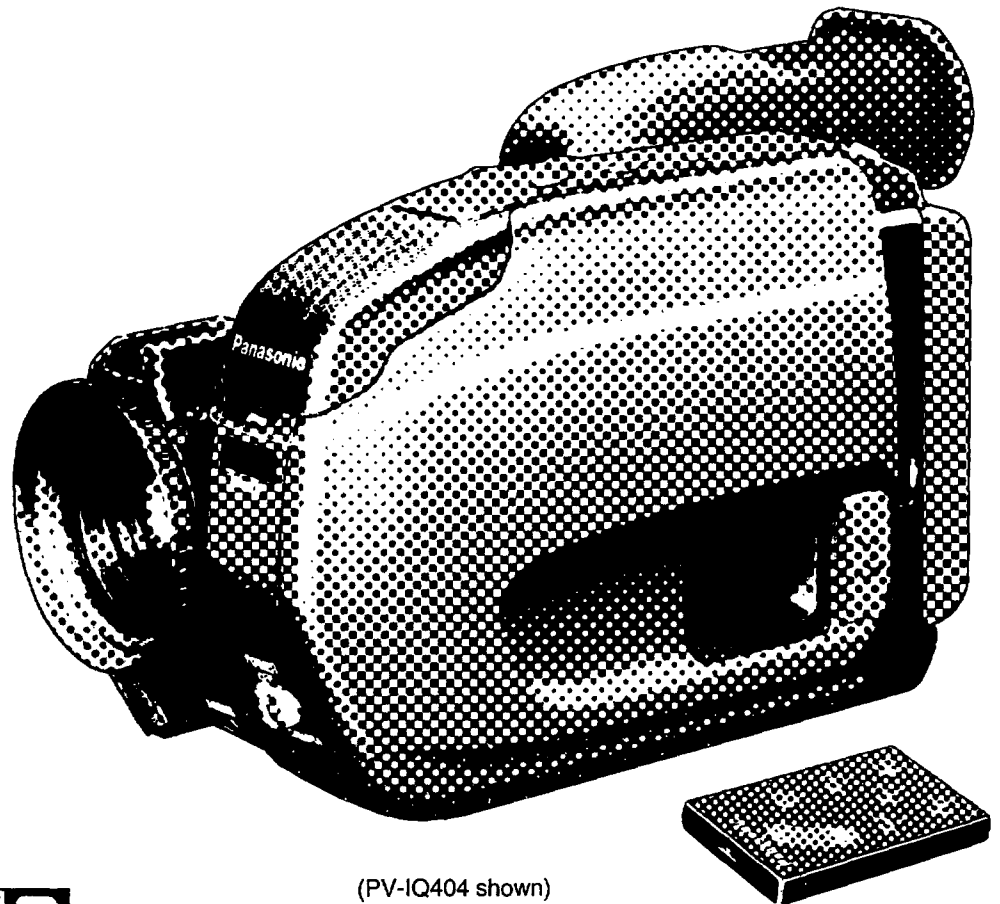

(PV-IQ404 shown)



PV-IQ304

Consists of PV-IQ304D/PV-A16

PV-IQ404

Consists of PV-IQ404D/PV-A16

Before attempting to connect, operate or adjust this product, please read these instructions thoroughly. Spanish Quick Use Guide is included. Guía para rápida consulta en español está incluida.

Things You Should Know

Thank you for choosing Panasonic!

You have purchased one of the most sophisticated and reliable products on the market today. Used properly, we're sure it will bring you and your family years of enjoyment. Please take time to fill in the information at right. The serial number is on the tag located on the underside of your Palmcorder. Be sure to retain this manual as your convenient Palmcorder information source.

Date of Purchase _____

Dealer Purchased From _____

Dealer Address _____

Dealer Phone No. _____

Model No. _____

Serial No. _____

Unpack your Palmcorder

These accessories are provided in order to set up or use your Palmcorder.

1 pc. AC Adaptor (PV-A16) with DC Power Cable

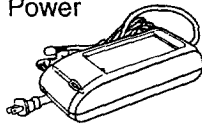

1 pc. Battery Pack (PV-BP15)



1 pc. Audio/Video Cable (VJAW0020)

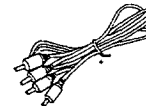

1 pc. VHS PlayPak (PV-P1) and one "AA" battery (VYMW0009)

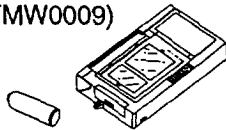

1 pc. 8-Function Remote (VSQW0009) with one CR2025 Battery

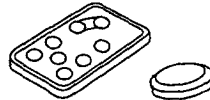

1 pc. CR2025 Clock Battery (VSBW0004)



1 pc. Shoulder Strap (VYCW0038)



Remote has been loaded with battery and comes stored in Palmcorder. See page 18.

Safety Precautions

WARNING: TO PREVENT FIRE OR SHOCK HAZARD, DO NOT EXPOSE THIS EQUIPMENT TO RAIN OR MOISTURE.

Your Compact VHS Palmcorder is designed to record and play back in Standard Play (SP) and Super Long Play (SLP) modes. You can also play a Compact VHS Palmcorder recording on your VHS VCR using the VHS PlayPak supplied.

This Palmcorder is equipped with the **HQ** System to provide excellent video pictures, and is compatible with standard VHS equipment. It is recommended that only cassette tapes that have been tested and inspected for use in VCR machines with the **VHS** and/or **VHS** mark be used.



This symbol warns the user that uninsulated voltage within the unit may have sufficient magnitude to cause electric shock. Therefore, it is dangerous to make any kind of contact with any inside part of this unit.

This symbol alerts the user that important literature concerning the operation and maintenance of this unit has been included. Therefore, it should be read carefully in order to avoid any problems.

Important Safeguards and Precautions

1. **Read Instructions** — All the safety and operating instructions should be read before the unit is operated.
2. **Retain Instructions** — The safety and operating instructions should be retained for future reference.
3. **Heed Warnings** — All warnings on the unit and in the operating instructions should be adhered to.
4. **Follow Instructions** — All operating and maintenance instructions should be followed.
5. **Cleaning** — Unplug this video unit from the wall outlet before cleaning. Do not use liquid or aerosol cleaners. Use a dry cloth for cleaning.
6. **Attachments** — Do not use attachments not recommended by the video product manufacturer as they may be hazardous.
7. **Water and Moisture** — Do not use this video unit near water — for example near a bath tub, wash bowl, kitchen sink, or laundry tub, in a wet basement, or near a swimming pool, and the like.
8. **Accessories** — Do not place this video unit on an unstable cart, stand, tripod, bracket, or table. The video unit may fall, causing serious injury to a child or adult, and serious damage to the unit. Use only with a cart, stand, tripod, bracket, or table recommended by the manufacturer, or sold with the video unit. Any mounting of the unit should follow the manufacturer's instructions and should use a mounting accessory recommended by the manufacturer. An appliance and cart combination should be moved with care. Quick stops, excessive force, and uneven surfaces may cause the appliance and cart combination to overturn.



9. **Ventilation** — Slots and openings in the cabinet are provided for ventilation and to ensure reliable operation of the video unit and to protect it from overheating. These openings must not be blocked or covered. Never place the video unit on a bed, sofa, rug, or other similar surface, or near or over a radiator or heat register. This video unit should not be placed in a built-in installation such as a bookcase or rack unless proper ventilation is provided or the manufacturer's instructions have been adhered to.
10. **Power Sources** — This video unit should be operated only from the type of power source indicated on the marking label. If you are not sure of the type of power supply to your home, consult your appliance dealer or local power company. For video units intended to be operated from battery power, or other sources, refer to the operating instructions.

11. **Grounding or Polarization** — This video unit may be equipped with either a polarized 2-wire AC (Alternating Current) line plug (a plug having one blade wider than the other) or 3-wire grounding type plug, a plug having a third (grounding) pin.

The 2-wire polarized plug will fit into the power outlet only one way. This is a safety feature. If you are unable to insert the plug fully into the outlet, try reversing the plug. If the plug still fails to fit, contact your electrician to replace your obsolete outlet. Do not defeat the safety purpose of the polarized plug.

The 3-wire grounding type plug will fit into a grounding type power outlet. This is a safety feature. If you are unable to insert the plug into the outlet, contact your electrician to replace your obsolete outlet. Do not defeat the safety purpose of the grounding type plug.

12. **Power-Cord Protection** — Power-supply cords should be routed so that they are not likely to be walked on or pinched by items placed upon or against them, paying particular attention to cords of plugs, convenience receptacles, and the point where they exit from the unit.
13. **Outdoor Antenna Grounding** — If an outside antenna or cable system is connected to the video unit, be sure the antenna or cable system is grounded so as to provide some protection against voltage surges and built-up static charges. Part 1 of the Canadian Electrical Code, in USA Section 810 of the National Electrical Code, provides information with respect to proper grounding of the mast and supporting structure, grounding of the lead-in wire to an antenna discharge unit, size of grounding conductors, location of antenna discharge unit, connection to grounding electrodes, and requirements for the grounding electrode.

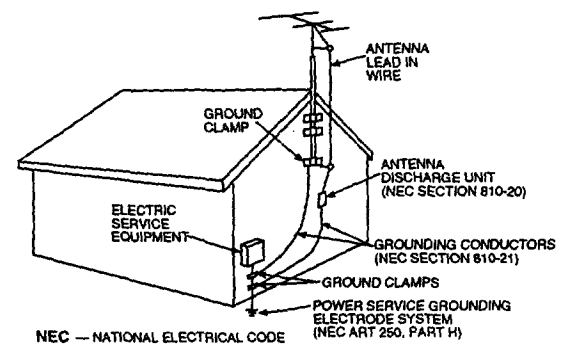

Important Safeguards and Precautions

14. **Lightning** — For added protection of this video unit receiver during a lightning storm, or when it is left unattended and unused for long periods of time, unplug it from the wall outlet and disconnect the antenna or cable system. This will prevent damage to the video unit due to lightning and power-line surges.
15. **Power Lines** — An outside antenna system should not be located in the vicinity of overhead power lines or other electric light or power circuits, or where it can fall into such power lines or circuits. When installing an outside antenna system, extreme care should be taken to keep from touching such power lines or circuits as contact with them might be fatal.
16. **Overloading** — Do not overload wall outlets and extension cords as this can result in a risk of fire or electric shock.
17. **Objects and Liquids** — Never push objects of any kind into this video unit through openings as they may touch dangerous voltage points or short out parts that could result in a fire or electric shock. Never spill liquid of any kind onto the video unit.
18. **Servicing** — Do not attempt to service this video unit yourself as opening or removing covers may expose you to dangerous voltage or other hazards. Refer all servicing to qualified service personnel.
19. **Damage Requiring Service** — Unplug this video unit from the wall outlet and refer servicing to qualified service personnel under the following conditions:
 - a. When the power-supply cord or plug is damaged.
 - b. If any liquid has been spilled onto, or objects have fallen into the video unit.
 - c. If the video unit has been exposed to rain or water.
 - d. If the video unit does not operate normally by following the operating instructions. Adjust only those controls that are covered by the operating instructions, as an improper adjustment of other controls may result in damage and will often require extensive work by a qualified technician to restore the video unit to its normal operation.
 - e. If the video unit has been dropped or the cabinet has been damaged.
 - f. When the video unit exhibits a distinct change in performance — this indicates a need for service.
20. **Replacement Parts** — When replacement parts are required, be sure the service technician has used replacement parts specified by the manufacturer or have the same characteristics as the original part. Unauthorized substitutions may result in fire, electric shock or other hazards.
21. **Safety Check**— Upon completion of any service or repairs to this video unit, ask the service technician to perform safety checks to determine that the video unit is in safe operating order.

Precautions

USE & LOCATION

- **TO AVOID SHOCK HAZARD ...** Your Camcorder and power supply should not be exposed to rain or moisture. Do not connect the power supply or operate your Camcorder if it gets wet. Your Camcorder has been designed for outdoor use, however it is not designed to sustain direct exposure to water, rain, sleet, snow, or a direct splashing from a pool or even a cup of coffee. Do not attempt to disassemble this unit. There are no user serviceable parts inside. Unplug your Camcorder from the power supply before cleaning.
- **DO NOT AIM YOUR CAMCORDER AT THE SUN OR OTHER BRIGHT OBJECTS**
- **DO NOT EXPOSE YOUR CAMCORDER TO EXTENDED HIGH TEMPERATURE ...** Such as, in direct sunlight, inside a closed car, next to heater, etc... This action could permanently damage the internal parts of your Camcorder.
- **AVOID SUDDEN CHANGES IN TEMPERATURE ...** If the unit is suddenly moved from a cold place to a warm place, moisture may form on the tape and inside the unit.
- **DO NOT LEAVE YOUR CAMCORDER OR THE POWER SUPPLY TURNED ON WHEN NOT IN USE**
- **STORAGE OF YOUR CAMCORDER ...** Store and handle your Camcorder in a manner that will not subject it to unnecessary movement (avoid shaking and striking). Your Camcorder contains a sensitive pick-up device which could be damaged by improper handling or storage.

CARE

- **TO CLEAN YOUR CAMCORDER ...** Do not use strong or abrasive detergents when cleaning your Camcorder body.
- **TO PROTECT THE LENS ...** Do not touch the surface of the lens with your hand. Use a commercial camcorder lens solution and lens paper when cleaning the lens. Improper cleaning can scratch the lens coating.
- **TO PROTECT THE FINISH OF YOUR CAMCORDER ...** Before handling your Camcorder, make sure your hands and face are free from any chemical products such as suntan lotion as it may damage the finish.

Table of Contents

Getting Started

Things You Should Know	2
Important Safeguards and Precautions	3
Palmcorder Accessory System	6
Attaching the Shoulder Strap	7
Supplying Power	8
Battery Care	10
Cassette Information	11
Setting the Date/Time	12
Electronic Viewfinder Indications	13
Color Enhancement Light (Optional)	15

Basic Operation

Camera Recording	16
8-Function Remote Control	18
Playback your Recordings	19

Special Features

Four Speed Power Zoom	22
Audio/Video Fade In/Out	22
Focusing	23
High Speed Shutter	24
Backlight Button	24
Copying your Tapes (dubbing)	25

For Your Information

Notes On Operations	26
Spanish Quick Use Guide/Guía Para Uso Rápido	28
Index of Controls	30
Index/Specifications	34
Before Requesting Service	35

This operating instruction book is designed for use with models PV-IQ304 and PV-IQ404. Illustrations in this manual show the PV-IQ404. Features may vary, so please read carefully.

Palmcorder Accessory System

For information and ordering instructions, see the separate Selection Guide and Accessory Order Form.

Power Supplies

Supplied Accessories

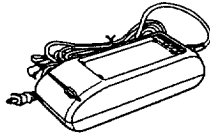

AC Adaptor
(PV-A16)



1.2Ah Battery Pack
(PV-BP15)

Optional Accessories



2.4Ah Battery Pack
(PV-BP17)



Car Battery Cord
(PV-C16)

To Transport

Supplied Accessories



Shoulder Strap
(VYCW0038)

Optional Accessories

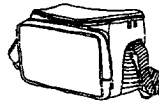

System Carrying Case
(PV-H18)

For Special Effects

Optional Accessories



Video Corrector
(PV-CC50)

To Copy your Tapes (with Video/Audio)

Supplied Accessories

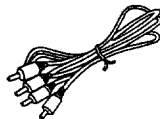

Audio/Video Cable
(VJAW0020)

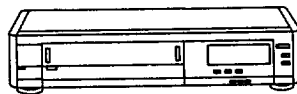

VCR (not supplied)

Connection

Supplied Accessories

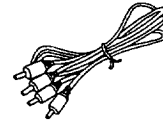

Audio/Video Cable
(VJAW0020)

Optional Accessories

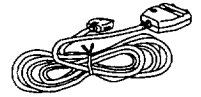

RF Adaptor
(PV-RF15)

To Record and Playback

Supplied Accessories

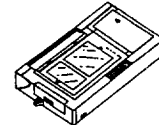

VHS PlayPak
(PV-P1)

Optional Accessories



Compact Video
Cassette Tape
(NV-TC20P,
NV-TC30P)

To Enhance your Recording

Optional Accessories

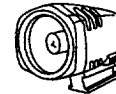

5W Color Enhancement
Light
(PV-L5)



Telephoto Lens
(PV-LT49)

Attaching the Shoulder Strap

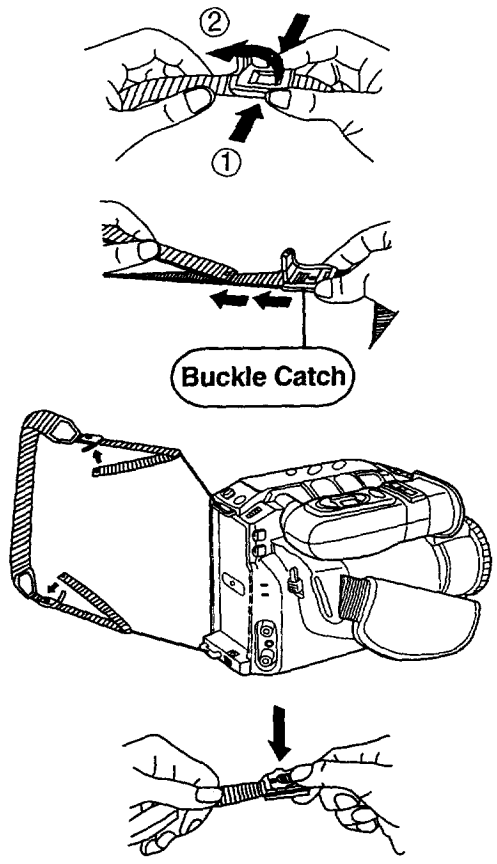

Buckle Catch

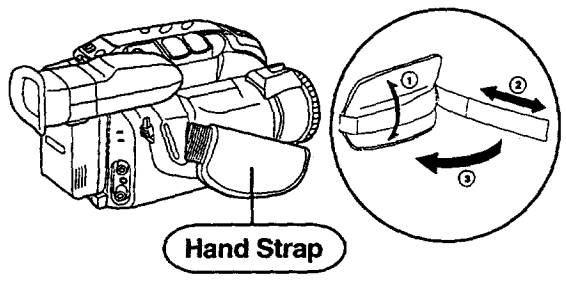
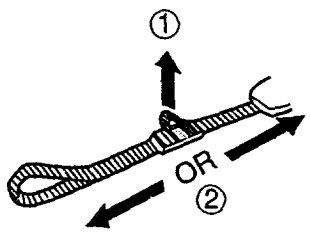

Hand Strap

Make sure the Battery Pack is not attached.

1

Pinch the tabs together on either side of the clasp and open the buckle.

2

Unhook the strap from the Buckle Catch.

3

Thread the strap ends through the Strap Attachment Rings. Then re-hook them onto the Buckle Catch.

4

Snap the clasp shut to lock the strap in place.

Adjust the Length

Pull a loop of the strap loose from the buckle, then pull the strap firmly through the buckle to adjust the length.

Hand Strap

Adjust the length to the size of your hand using the illustration at left as a guide.

Supplying Power

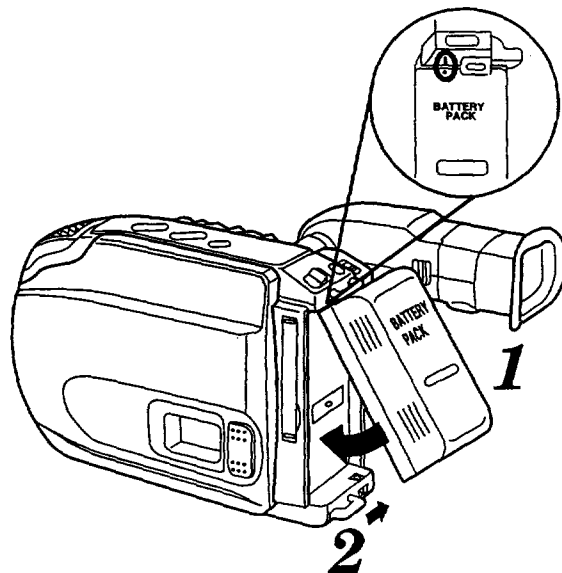
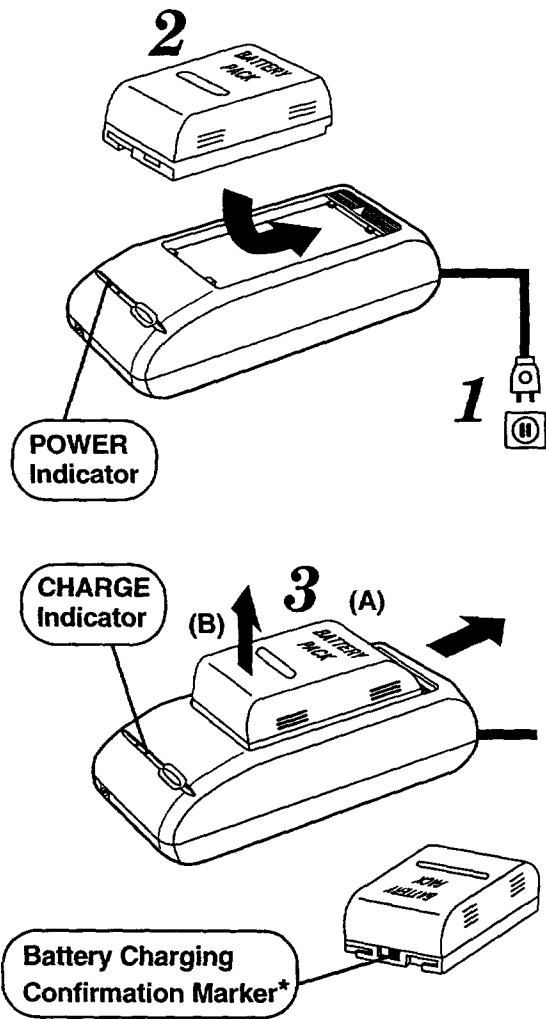

Charge the Battery Pack

Charge the Battery Pack fully before operation.

1

Plug in the AC Adaptor.

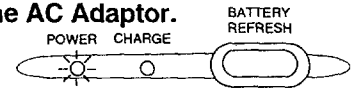

2

Power Indicator lights up.

Insert the Battery

Slide the top of the Battery forward then press down until it locks with a click.

• Battery Pack charges in about 1 hour.

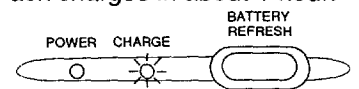

3

Charge Indicator lights up.

Remove the Battery

(A) Slide Battery forward.

(B) Lift up and out.

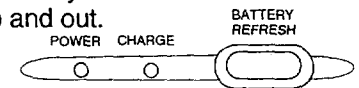

Charge Indicator goes out when charging is done. (About one hour.)

• With a fully charged Battery Pack, you will have about 1 hour of continuous use.

Use the Battery completely before recharging.

Note:

After recharging the Battery Pack about 5 times, use the BATTERY REFRESH feature as explained on page 10.

*Use this marker as a reminder to yourself when the battery is fully charged or in need of a charge. This marker performs no function and is for your reference only.

Use the Battery Pack

1

To Attach the Battery

Align the battery with the top of the mounting surface and press it firmly into place until it locks with a click.

2

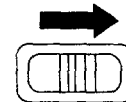

To Remove the Battery

While sliding the BATTERY RELEASE button, remove the Battery from the mounting surface.

Supplying Power

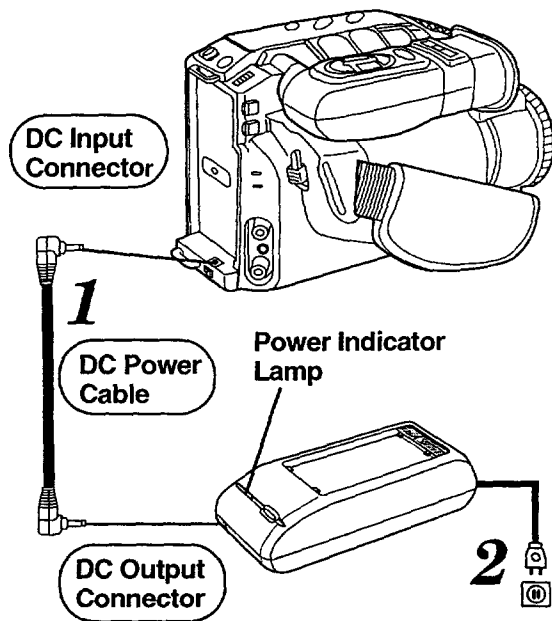

AC Adaptor (Supplied)

1

Connect the DC Output on the AC Adaptor to the DC Input on the Palmcorder with the DC Power Cable (supplied).

2

Plug in the AC Adaptor.

- The Power indicator will light up.

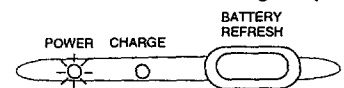

Note:

AC Adaptor does not function while charging the Battery.

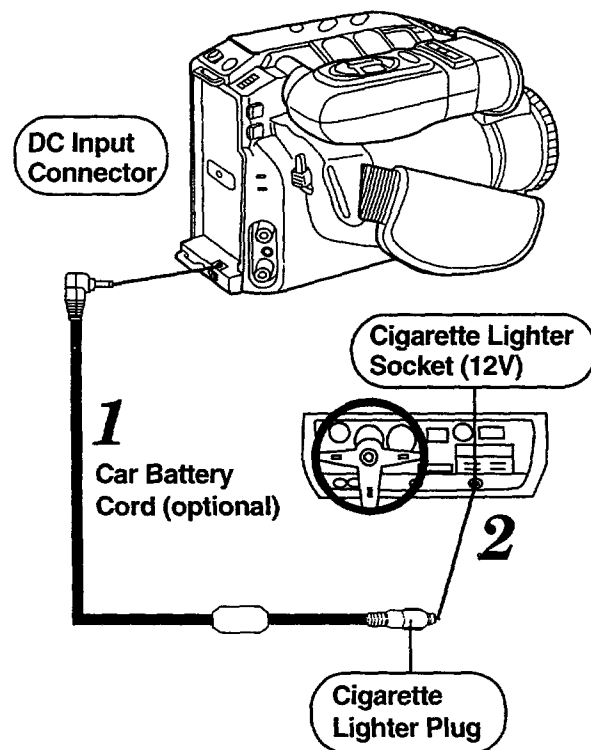

Car Battery Cord (Optional)

1

Connect a PV-C16 Car Battery Cord to the DC Input of the Palmcorder.

2

Start your car engine and then insert the Car Battery Cord plug into your cigarette lighter socket.

- There is a fuse located in the lighter plug end of the cord.
Should fuse replacement be necessary use the exact current rating (in amps).

Note:

This cord can only be used in vehicles equipped with DC 12V (negative ground) batteries.

Use only the specified car battery cord.

Battery Care

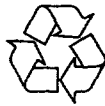
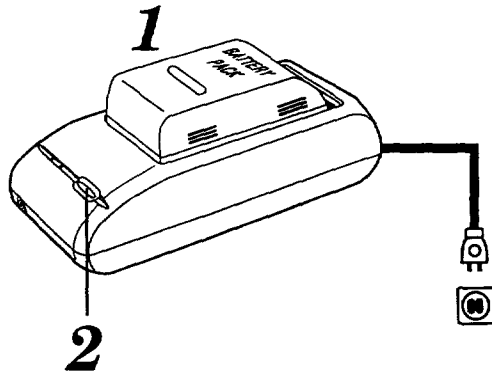

Ni-Cd

ATTENTION:

The product that you have purchased is powered by a rechargeable battery. The battery is recyclable. At the end of its useful life, under various state and local laws, it may be illegal to dispose of this battery into the municipal waste stream. Check with your local solid waste officials for details in your area for recycling options or proper disposal.

Caution:

- Charge only with specified charger.
- The battery pack can be charged within a temperature range of 32° F (0° C) and 104° F (40° C).
- The battery pack may be warm after charging or just after use. This is normal.
- Do not use an insufficiently charged or worn out battery pack.

Safety precautions:

- Do not get the battery near, or dispose of in, fire.
- Do not directly connect (short circuit) the positive (+) and negative (-) terminals.
- Never attempt to disassemble or reassemble the battery pack.

Battery Refresh Feature

This feature completely discharges the Battery before recharging begins. To keep your Battery in top condition, use Refresh after about every 5 charges.

1

Place the Battery into the AC Adaptor.

2



Press the **BATTERY REFRESH** button. The Charging indicator will flash when discharging begins and stop flashing when complete.

- Should you accidentally press the **BATTERY REFRESH** button, remove the battery pack and then re-insert it to begin charging.
- It takes about 5 hours when both Battery Refresh and charging are performed.

To avoid damage to the Battery Pack:

- Do not drop or jar the battery pack.
- Use the battery pack with specified units only.
- If the battery pack is used in extremely high temperatures, a safety device will automatically prevent operation.

To insure longer battery life:

- While not in use, remove battery pack from the Palmcorder and AC Adaptor and store in a cool, dark, dry place.
- Keep the battery pack terminals clean.

Cassette Information

Record/Playback Time

Use tapes with the **VHS** mark in this unit.

Tape Speed Selector Position	Cassette type		
	T-20	T-30	T-40
SP (Standard Play)	20 Minutes	30 Minutes	40 Minutes
SLP (Super Long Play)	One Hour	One Hour 30 Minutes	Two Hours

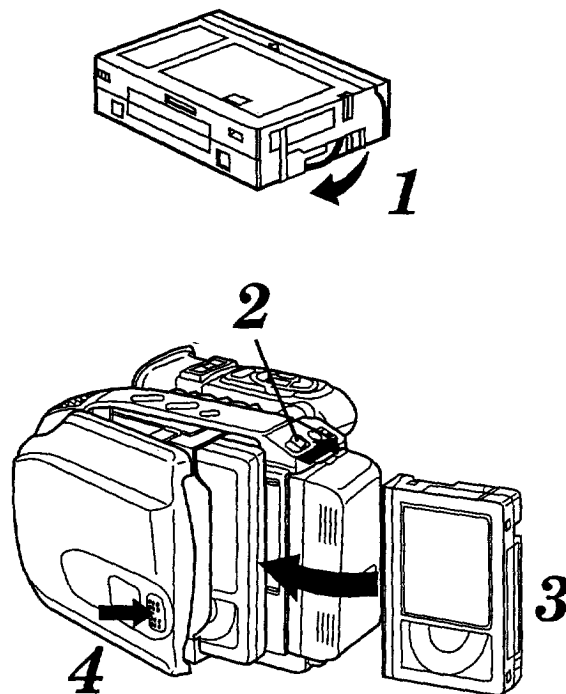

Cassette Insertion/Removal

Connect the Palmcorder to a power source.

1

Turn the **Tape Wheel** in the direction of the arrow until there is no slack.

2

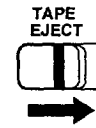

Slide the **TAPE EJECT** switch to open the door.

3

Insert the **cassette vertically** with the window facing away from the Palmcorder body.

4

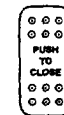

Press **PUSH TO CLOSE** to close the door.

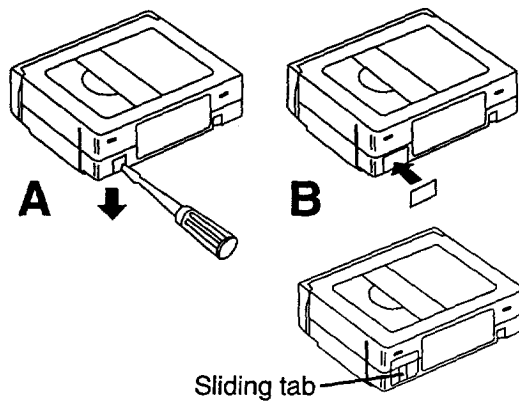

Erase Protection Tab

Cassettes have a record tab to ensure that recordings are not accidentally erased.

A To prevent accidental erasure
Break off the tab with a screwdriver.
(Some tapes have a sliding tab.)

B To record again
Cover the hole with cellophane tape.

Setting the Date/Time

The date and time is calculated, including leap year, up to Dec. 31, 2089. This function operates on a miniature battery (supplied).

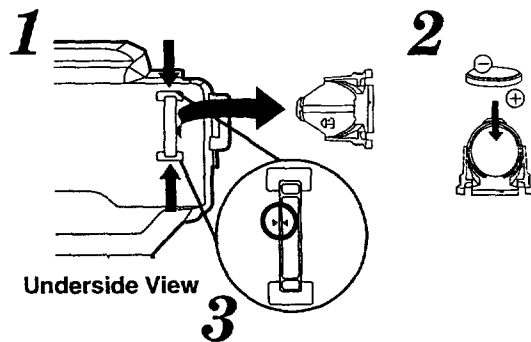

How to remove the Battery.

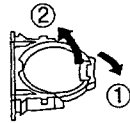

- ① Bend the lock tab outward.
- ② Remove the battery.

REPLACE BATTERY WITH PANASONIC PART NO. VSBW0004 (CR2025) ONLY. USE OF ANOTHER BATTERY MAY PRESENT A RISK OF FIRE OR EXPLOSION. CAUTION-BATTERY MAY EXPLODE IF MISTREATED. DISPOSE OF USED BATTERY PROMPTLY. KEEP AWAY FROM CHILDREN. DO NOT RECHARGE, DISASSEMBLE OR DISPOSE OF IN FIRE.

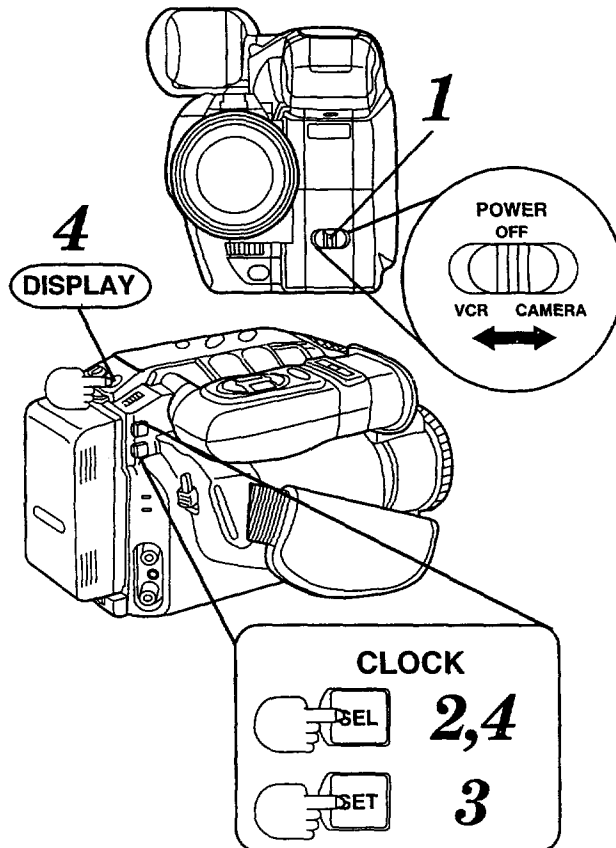

Load the Battery

1 While pinching the stopper tabs, pull the tray out of the Battery Compartment.

2 Insert the battery (supplied) into the Battery tray with the ⊕ mark facing down until it snaps into place.

- Do not reverse the polarity.

3 Replace the Battery tray so that the small triangle marks meet.

Note:

- Make sure your Palmcorder is off when replacing the battery.
- Keep the Battery out of the reach of children since swallowing it may be harmful.
- When the Battery is installed improperly, is discharged, or missing, the words "CLOCK BATTERY" appears on the EVF.
- Battery life is approximately 5 years.

Set the Date and Time

Connect the Palmcorder to a power source.

1 Set the POWER switch to VCR or CAMERA.

2 Press SEL(ect) to start the first portion flashing.

3 Press SET repeatedly (or hold down) to enter the desired numbers. Then, press SEL(ect) to fix that portion and move to the next.

Repeat until the hour, minute, month, day and year have been entered.

4 Press SEL(ect) again to lock in all the settings and start the clock. Press DISPLAY twice to remove display from EVF.

Note: Whenever "12:00AM JAN. 1 1994" appears, it indicates that the clock needs adjustment.

Electronic Viewfinder Indications

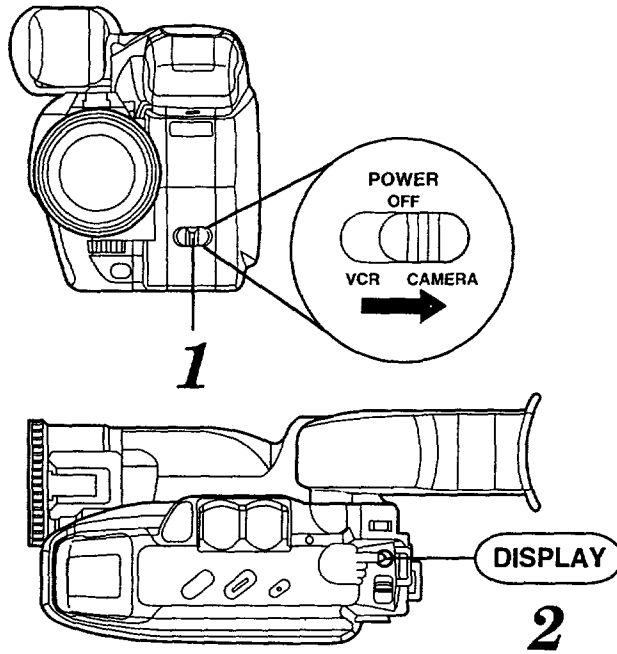

Note:
The tape remaining indication will not function with T-40 tapes.

EVF Indications

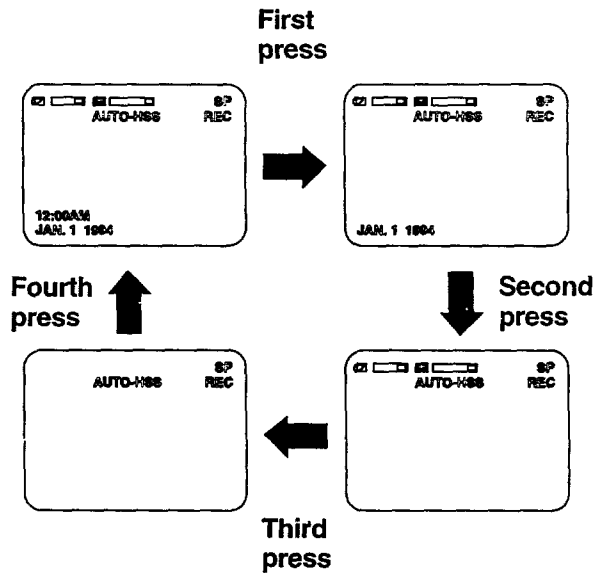

Note:
In the VCR mode, the display can only be changed while the tape is stopped.
Only the Date and Time are recorded on the Tape.

Tape/Battery Remaining

The tape remaining and battery charge level can be displayed during recording.

1 Set the POWER switch to CAMERA.

2 Press DISPLAY repeatedly to select the desired display.

Battery Charge Remaining:

Tape Remaining:

FULL

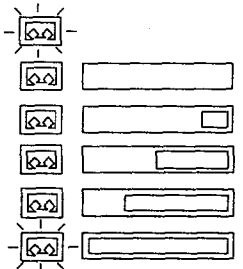
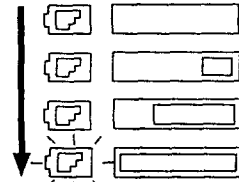

EMPTY

- It will take several seconds for the tape remaining indicator to operate after the tape starts moving.

Record the Date and Time

1 Set the POWER switch to CAMERA. When placed in Record mode, the time and date will be recorded on the tape.

2 Press DISPLAY once to change the display to date only. Press once or twice more to remove the date/time display.

Electronic Viewfinder Indications

Here are some of the basic indications which appear in the Palmcorder EVF. They will not be recorded on the tape.

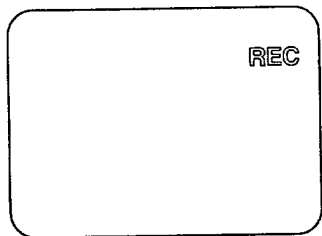

Operating Mode Indications

REC (record)
PAUSE
FF (fast forward)
PLAY
REW (rewind)

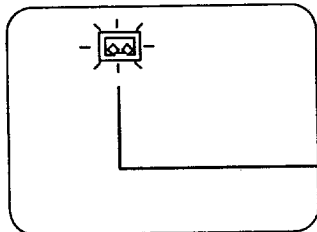

Tape Warning Indications



This indicator flashes when the tape is about to end in REC mode.



If the record tab is missing, this indicator will flash and recording will not start.

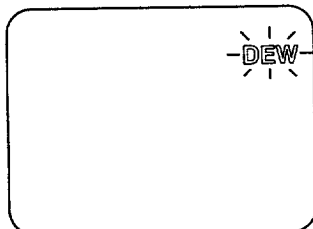

DEW
 If excessive moisture condenses in the unit, it will not operate. This indicator will flash for several seconds and the Palmcorder will automatically turn OFF. In this case, wait until the indicator no longer flashes when your Palmcorder is turned on again.

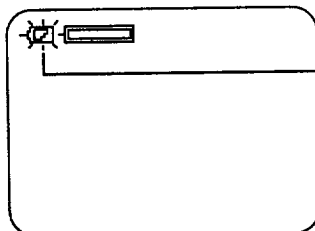

Battery Warning Indication

The battery icon and Power Indicator will flash for a few minutes prior to automatic power shut off. When this happens, a battery recharge is necessary.

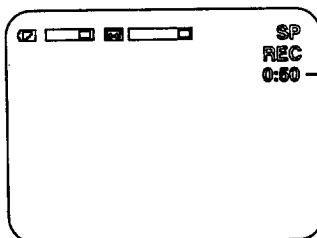

10-Second Reminder

An elapsed time indicator appears for one second every 10 seconds that recording continues.

This is a reminder of how long you have been shooting a particular scene and can help keep your recordings fresh and interesting.

0:00 0:10 0:20 59:50



(return to 0:00 and continue)

- 10-Second Reminder will be reset whenever you press Record/Pause.

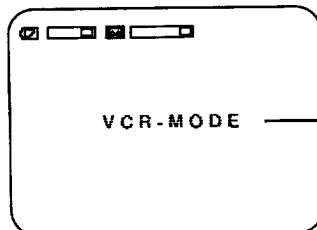

VCR-MODE Indication

"VCR-MODE" will appear for one minute if the POWER switch is set to VCR or the RECORD/PAUSE button is pushed in VCR Mode.

Color Enhancement Light (Optional)

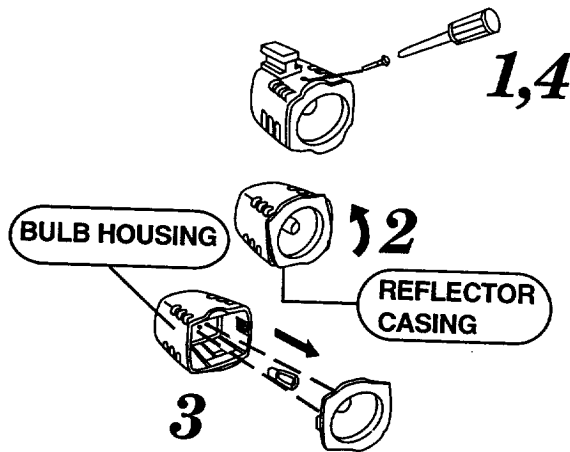
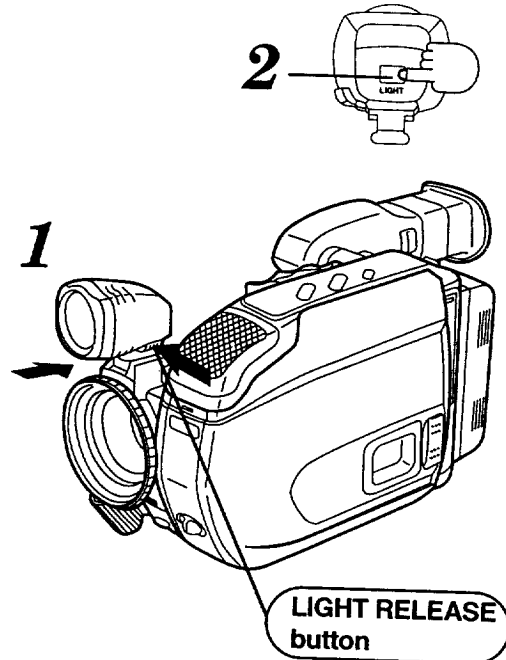

Danger:

- When replacing the bulb, use only lamp bulbs (PART NO. VLLW0003) supplied by Panasonic to reduce the risk of fire. Use a cloth or tissue when handling the bulb as finger oils will decrease the bulb life. To prevent possible burn hazard, disconnect the Color Enhancement Light Unit and allow the lamp to cool before replacing.
- Do not connect any light other than the standard light included. Use of a different light, modification to the light connector or light jack may cause severe battery drain and fire hazard.

Using the 5W Light

To brighten the natural colors in a scene.

1

Slide Light into built-in Light Mount. Be sure it locks into place.

2

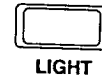

Press LIGHT button ON.

To remove the Light:



Press Light RELEASE button and slide the Light out of the mount.

CAUTION:

This light becomes hot during operation.

Replacing the Bulb

1

Turn screw counterclockwise on the underside of the reflector casing and remove.

2

Turn reflector casing counterclockwise only as far as shown in the diagram and pull it off the bulb housing.

3

Using a clean cloth or tissue, replace the bulb.

4

Replace the reflector casing turning it clockwise. Replace the screw.

Note:

- If using the Enhancement Light for an extended period of time, be sure to provide ventilation when using in a hot environment.
- Using the Enhancement Light when the Palmcorder is powered by a car battery may shorten bulb life.
- Do not attempt to lift or carry the Palmcorder by holding the Enhancement Light.

Camera Recording

Before you begin...

- Connect the Palmcorder to a power source (Battery Pack, AC Adaptor or Car Battery Cord.)
- Insert a cassette with record tab (see page 11).

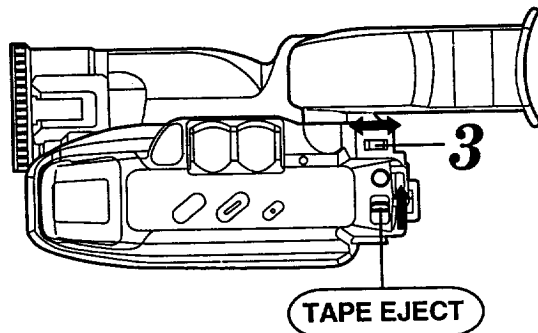
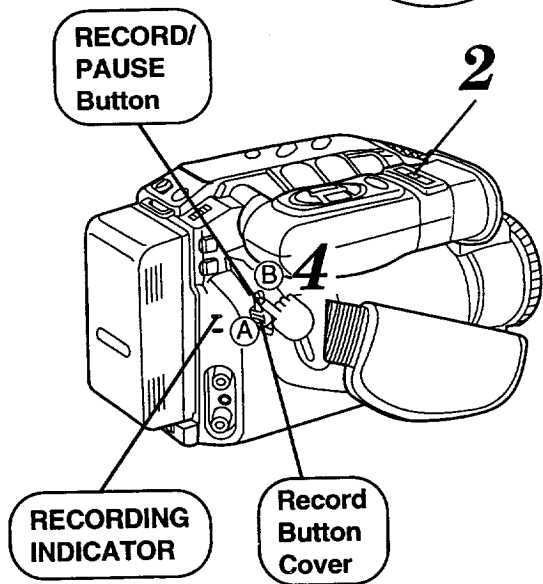
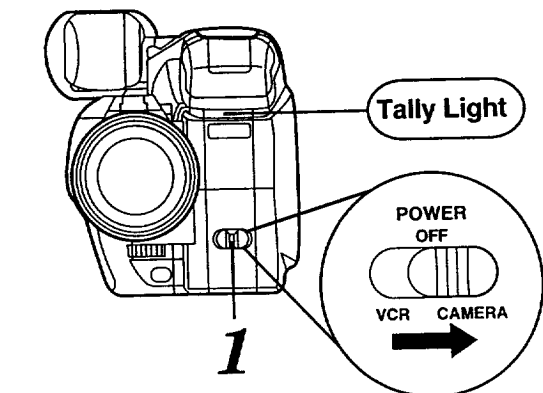

Simple Recording

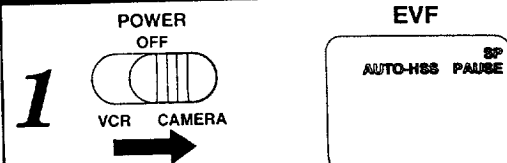

1 Set the **POWER** switch to **CAMERA**. Built-In Lens Cover opens.

Record/Pause mode.

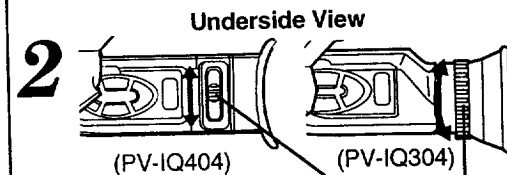

2 With the Eye Cup against your eye, adjust the Vision Adjustment Control to your eyesight.

Vision Adjustment Control

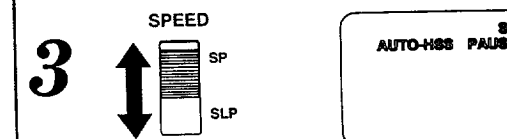

3 Slide the **TAPE SPEED** Selector for (SP or SLP). (Refer to page 11.)

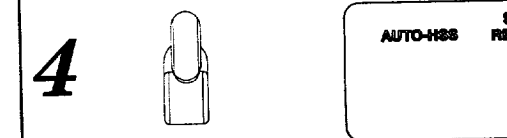

- 4**
- (A) Slide the **Record Button Cover** up or down to protect or access the Record button.
 - (B) Press **RECORD/PAUSE** to start recording. The Tally Light and Recording Indicator are lit during recording.

Press **RECORD/PAUSE** again to pause recording.

Helpful Notes:

- **To remove the cassette**
In Record/Pause mode, slide the **TAPE EJECT** switch.

To conserve power
After 5 minutes Record/Pause will automatically go into Standby mode. To resume recording, set the **POWER** switch to OFF and then **CAMERA**.

Camera Recording

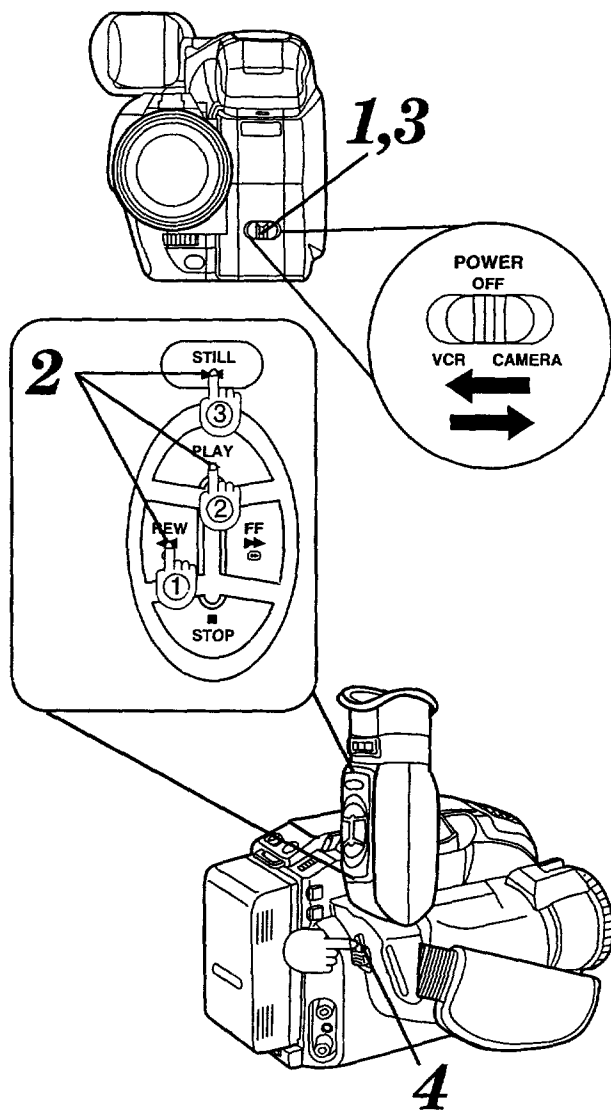
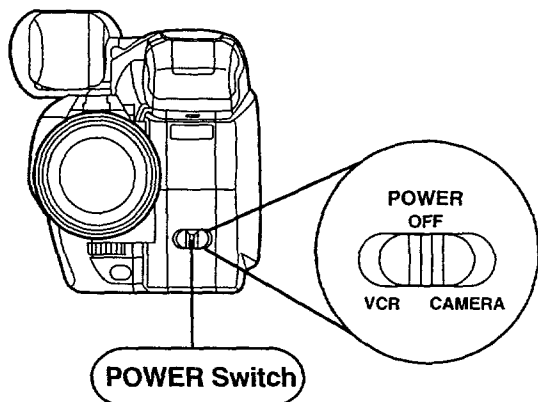

Easy Edit Standby

If you stop recording but plan to resume within 24 hours, use the Edit Standby feature to make a smooth transition between scenes.

Set the **POWER** switch to **OFF** while in **Record/Pause** mode and leave the cassette in the Palmcorder.

Set the **POWER** switch to **CAMERA** and press **RECORD/PAUSE** (within 24 hours) to continue recording.

Note:

- If it is longer than 24 hours before you resume recording, use the manual Easy Edit feature described below.
- To extend battery life, remove battery from Palmcorder when not in use.

Manual Easy Editing

For proper continuity when taping from the Stop mode, or after charging the Battery Pack.

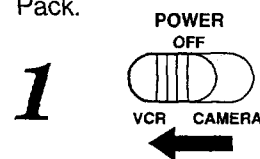

Set the **POWER** switch to **VCR**.

2 Press **REWIND** to go back a few seconds on the tape.

Then, press **PLAY** to review the picture on the Viewfinder.

Now, press **STILL** at the location you wish to continue your recording.

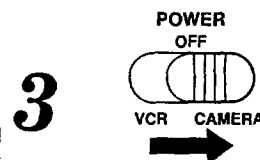

Set the **POWER** switch to **CAMERA**. Your Palmcorder will go into the Record/Pause mode.



Press **RECORD/PAUSE** to continue recording.

8-Function Remote Control

Operate the major functions of your Palmcorder from up to 16 feet (5 m) (approx.) away.

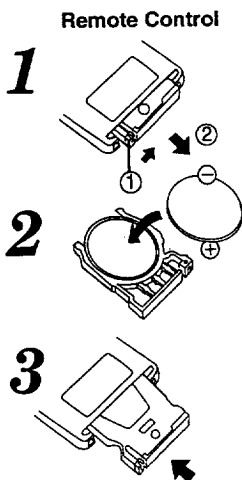
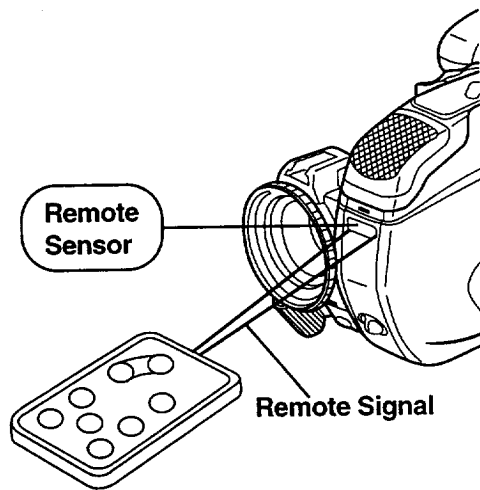
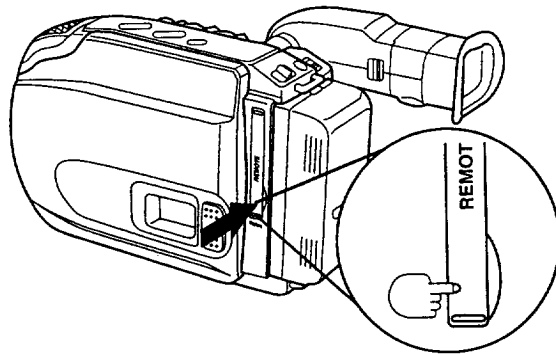

Remote Control

REPLACE BATTERY WITH PANASONIC PART NO. VSBW0004 (CR2025) ONLY. USE OF ANOTHER BATTERY MAY PRESENT A RISK OF FIRE OR EXPLOSION. CAUTION-BATTERY MAY EXPLODE IF MISTREATED. DISPOSE OF USED BATTERY PROMPTLY. KEEP AWAY FROM CHILDREN. DO NOT RECHARGE, DISASSEMBLE OR DISPOSE OF IN FIRE.

Removing and Storing the Remote

To remove,
press in on the Remote itself and release. The Remote ejects for removal.

To store
into the slot, as shown by the arrow, until it locks into place.

Remote Control Operation

Aim at the Remote Sensor and press the desired buttons.

Controlled Functions	VCR MODE	CAMERA MODE
REC/PAUSE	-	0
T(telephoto) Zoom	-	0
W(wide angle) Zoom	-	0
PLAY	0	-
FF/SEARCH	0	-
REW/SEARCH	0	-
STOP	0	-
STILL	0	-

- After 5 minutes in the Rec/Pause mode, the Palmcorder will go into the Standby mode (power will shut off) to conserve battery life. In this case, press REC/PAUSE down for about one second, the Palmcorder comes back on and goes into the Record mode.

Replace the Battery

- 1 While pinching the stopper tab, pull the Battery Tray out.
- 2 Insert the battery (supplied) into the Battery Tray with the ⊕ mark facing down. Do not reverse the polarity.
- 3 Replace the Battery Tray.

Playback your Recordings

Before you begin...

- Connect the Palmcorder to a power source.
- Insert a cassette.

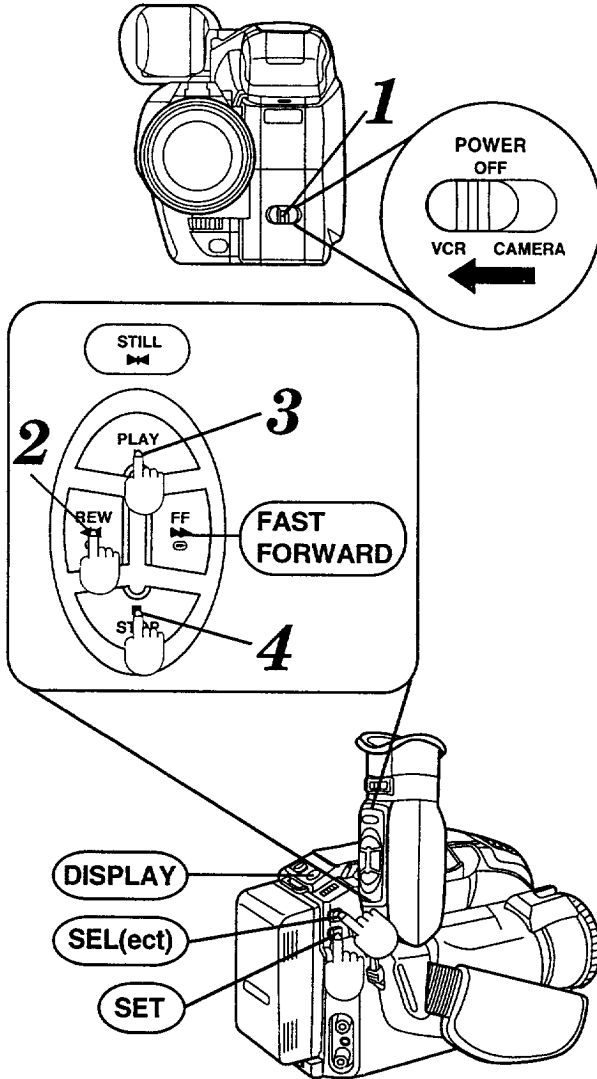



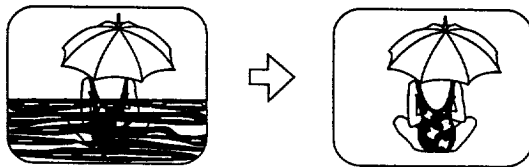

Helpful Note

Search Speed

Standard Play (SP) Search is about 3 times the normal speed, and Super Long Play (SLP) Search is about 9 times the normal speed.



Playback using the EVF

-  **1** Set the POWER switch to VCR.
-  **2** Press REW/SEARCH to rewind the tape.
-  **3** Press PLAY to start playback.
-  **4** Press STOP to stop playback.

Special Effect Playback Features During Playback

(Sound is Muted)

Rapidly Locate a Scene

Press FF or REW for a rapid visual search. Press again, or press PLAY to resume normal speed.

View a Still Picture

Press STILL to freeze the playback picture. Press again to resume normal playback.

Tracking Control

Auto Tracking

Continuously analyzes the signal of each recording for optimum picture quality.

Manual Tracking

To minimize the noise in some recordings, manual tracking may be necessary.

In Playback mode:

- Press SET or SEL(ect) until picture clears.
- Press DISPLAY to return to Auto Tracking.

Playback your Recordings

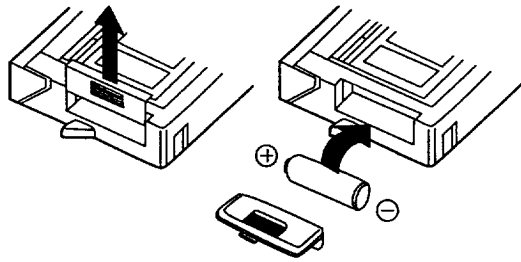

Playback using the PlayPak

Remove the Battery Compartment lid and insert the AA size battery (supplied).

- Make sure polarities are aligned properly.
- When tape loading and unloading time becomes longer than normal, battery replacement is necessary.

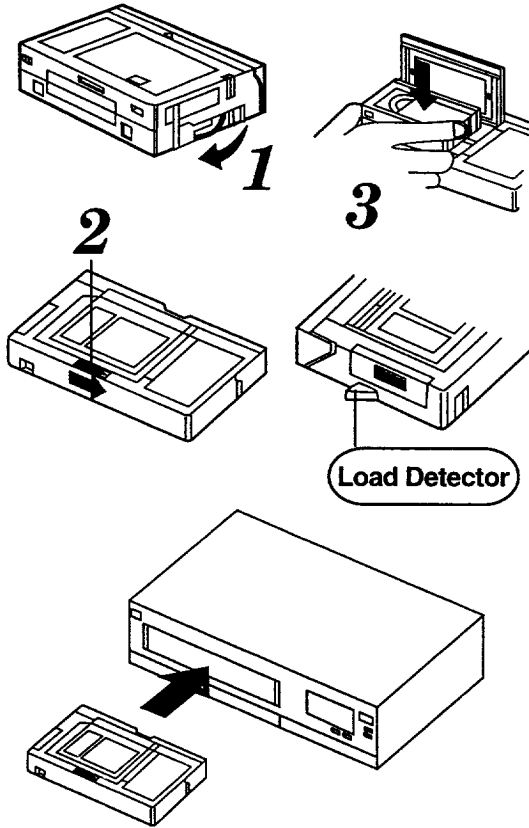

Insert Cassette

1

Turn the Tape Wheel on the **VHS** cassette in the direction of the arrow to take up any slack before placing the cassette in the PlayPak.

2



Slide the **RELEASE** button to open the PlayPak door.

3

Insert the **VHS** cassette with the window facing up and to the left. Then, snap the lid shut.

- Let the Load Detector fully retract before using the PlayPak in your standard VHS VCR.
- Be sure the cassette reel area under the PlayPak is free to turn while loading.

Remove Cassette



Slide the **RELEASE** button and wait for lid to open.

Hold the PlayPak securely in one hand. Then push the cassette out through the hole in the bottom of the PlayPak with your finger and remove.

Playback your Recordings

Your Palmcorder may be connected to a TV to play back tapes or to monitor what you are recording.

TV with AUDIO/VIDEO IN Jacks.

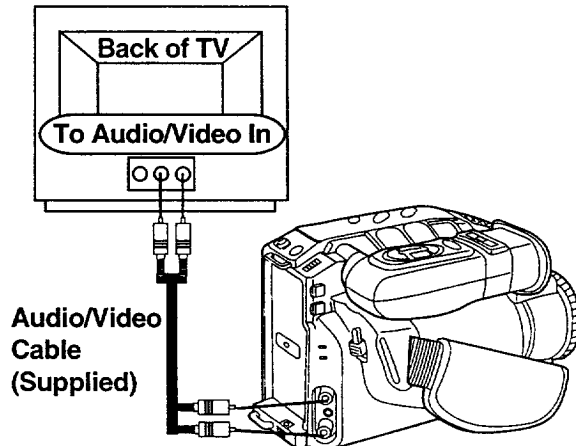

To Audio/Video Out

TV without AUDIO/VIDEO IN Jacks.

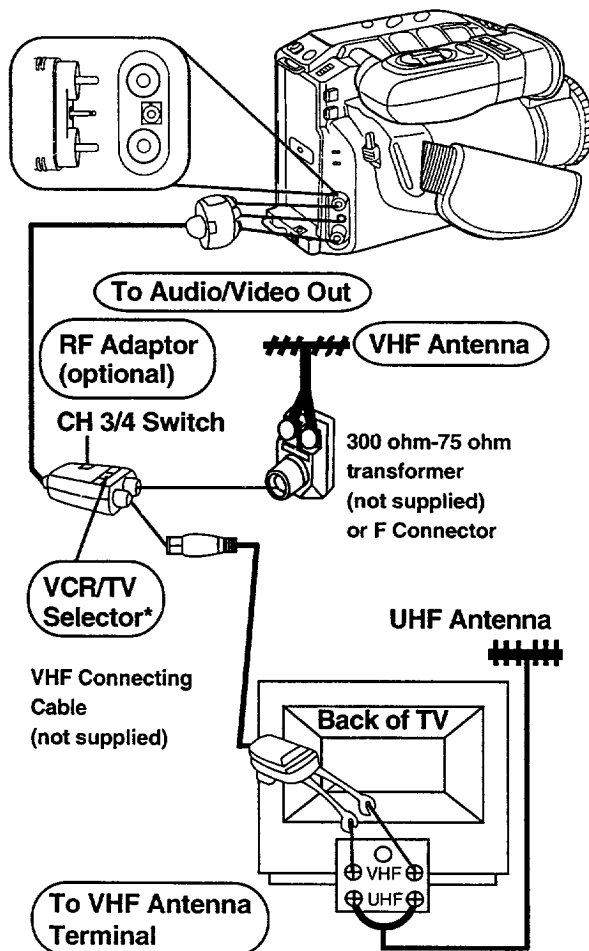

Playback or Monitor using a TV

1 Connect your Palmcorder to a power source (Battery Pack, AC Adaptor or Car Battery cord).

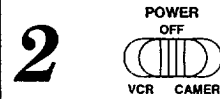

2 Set the **POWER** switch to **VCR** to playback a tape.
Or, set to **CAMERA** to monitor what your Palmcorder is recording.

3 Turn the TV **ON** and set it to **LINE INPUT**.
Check your TV operating instructions for further information.

Note:

If your TV has no VIDEO or AUDIO IN Jacks, select CH 3 or 4 on your TV to match the RF Adaptor CH 3/4 switch and set the VCR/TV selector on the RF Adaptor to VCR.

4 Start playback or begin a recording.

Display off Mode

This feature allows you to remove all Electronic Viewfinder Indications.

Before inserting a tape, press DISPLAY and STOP together for more than one second to remove the indications except time and date*.

To display the Electronic Viewfinder Indications again, **turn the Palmcorder Power off and then again on.**

* To remove the time and date, refer to page 13.

To watch TV only

If you have connected the Palmcorder to your TV using an RF Adaptor:

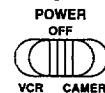

Set the **POWER** switch to **OFF** on the Palmcorder.

*Then, set the **VCR/TV Selector** on the RF Adaptor to **TV**.

Now, turn the TV **ON** and select a channel.

Special Features

Zoom In ("T")

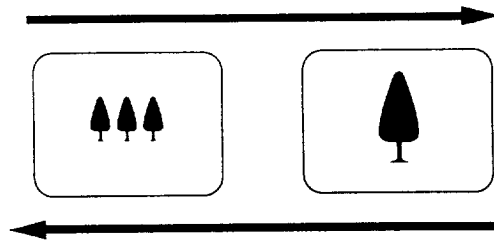

Zoom Out ("W")

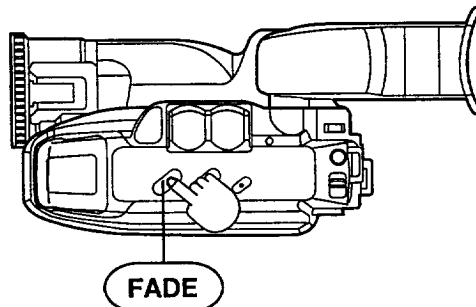
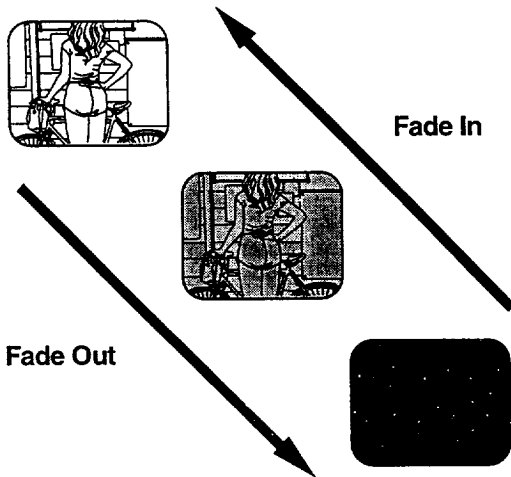
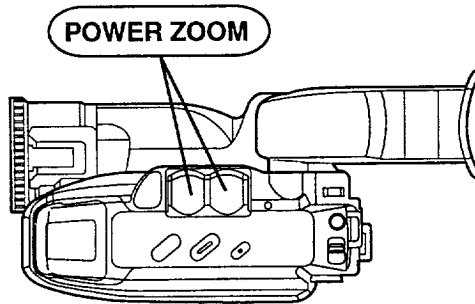

Four Speed Power Zoom

You can gradually zoom in for close ups or zoom out for wide angle shots.

The zooming speed ranges from a slow speed of 15 seconds to a fast 3 seconds according to the pressure applied to the zoom buttons.

Zoom slowly by lightly pressing the "T" (Telephoto) or the "W" (Wide Angle) side of the POWER ZOOM switch.

Zoom quickly by applying more pressure.

- The magnification level is displayed in the EVF.

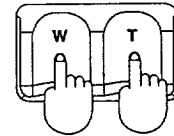

Audio/Video Fade In/Out

This feature allows you to make smoother scene transitions for a professional look.

Set the POWER switch to CAMERA.

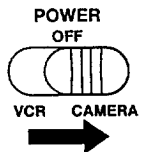

Fade In:

Hold down the FADE button until the picture and sound fade out.

Then, press RECORD/PAUSE to start recording.

Now, release the FADE button and the picture and sound will gradually fade in.

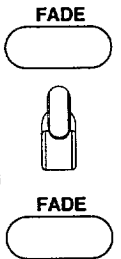

Fade Out:

(Recording is in progress.)

Hold down the FADE button until the picture and sound fade out.

Then, press RECORD/PAUSE to pause the recording.

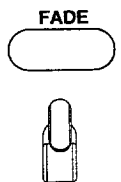

Use Manual Focus when recording ...

- a subject through glass.
- a scene where the subject is far from the Palmcorder and there are objects in the foreground.
- a subject with distinct horizontal stripes.
- a subject not centered in the Viewfinder.
- subjects with shiny surfaces.
- an obliquely angled subject.
- a bright, flat subject such as a white wall.
- in low light situations.
- a scene with fast motions, like a golf swing.
- **Re-focusing may be required** when your Palmcorder is aimed at a new scene.

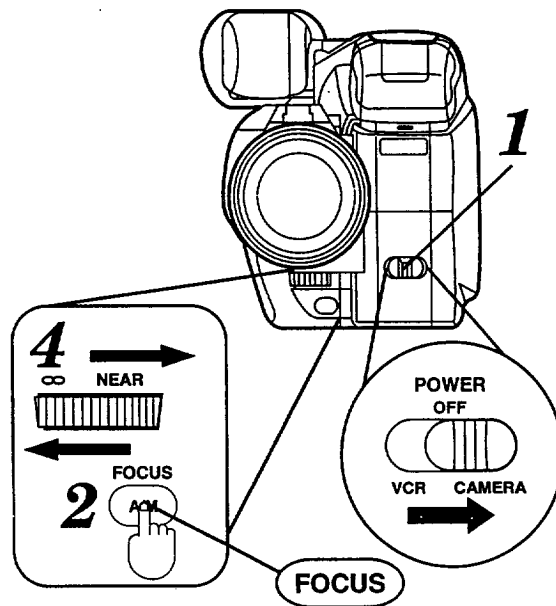
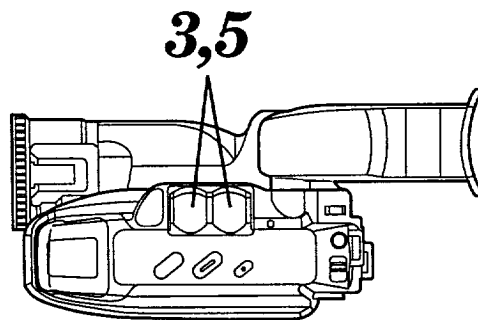

Auto Focus

The Palmcorder will automatically bring the subject into focus even during zooming.

Press **FOCUS A/M** if necessary, so that the letters "MF" do not appear in the EVF.

Manual Focus

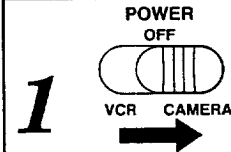

1 Set the **POWER** switch to **CAMERA**.



2 Press **FOCUS** so that "MF" (Manual Focus) appears in the EVF.

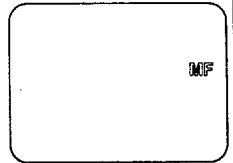

3 Press and hold the "T" side of the **POWER ZOOM** switch until the subject to be recorded is at maximum zoom-in.

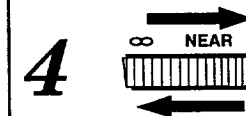

4 Turn the ∞ (**FAR**) / **NEAR** dial until the picture is in focus.

- It may be necessary to back away from the subject to focus the image properly.

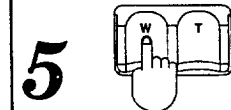

5 Press the "W" side of the **POWER ZOOM** switch to frame the picture as desired.

Macro Focus (for close-ups)

Auto Focus will function down to 1/2 inch (12.7mm) in front of the lens.

Press the "W" side of the **POWER ZOOM** switch to the wide angle position.

Then, bring the Palmcorder as close to the subject as necessary.

Special Features

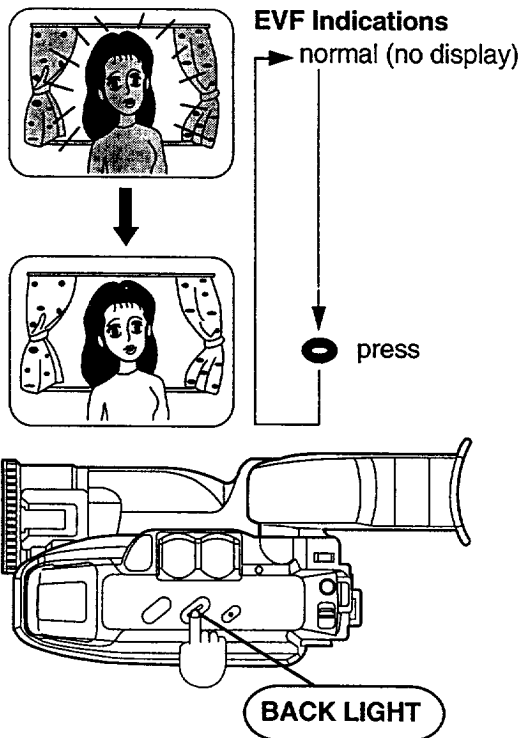
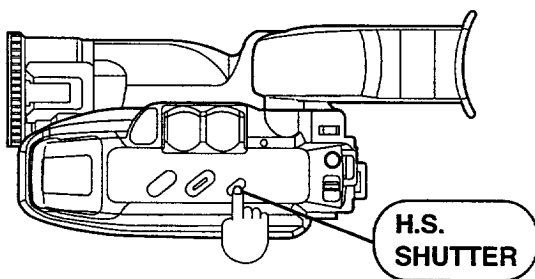
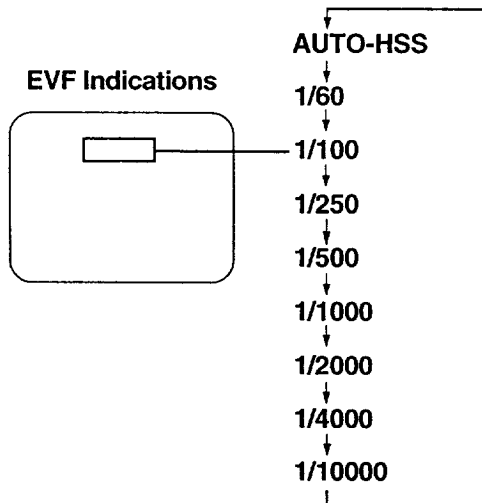

High Speed Shutter

To record high speed motion (e.g. a tennis stroke) for improved replay in STILL or SLOW mode.

Auto Shutter

In the AUTO mode ("AUTO-HSS" is displayed in the EVF), the Palmcorder will automatically adjust the shutter speed from 1/60 to 1/250 according to the brightness of the subject. The speed does not appear in the EVF.

- AUTO mode is automatically selected when the POWER switch is set to CAMERA.

Manual Selection

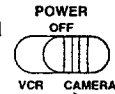

1

Set the POWER switch to CAMERA.

H.S.SHUTTER

2



Press HIGH SPEED SHUTTER while recording.

H.S.SHUTTER

3

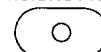

Press repeatedly to obtain one of the eight higher shutter speeds shown at left.

The High Speed Shutter indicator flashes when the light level is inadequate. More light should be provided to achieve better picture quality and color. (See page 26.)

Backlight Button

Use when recording a subject that is darker than the surrounding scene, in a shadowed area or when the light source is in back of your subject.

1

BACK LIGHT

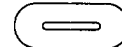

Press BACKLIGHT while recording.

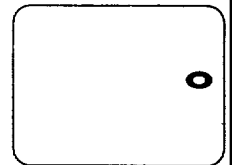

Indication appears in the EVF.

2

BACK LIGHT

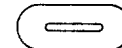

When lighting conditions return to normal, press BACKLIGHT again to disengage.

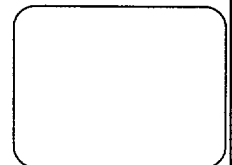

Indication disappears

Copying your Tapes (dubbing)

Before you begin...

- Turn ON both units.
- Set the recording VCR's Input Signal Selector to LINE.
- Set the Palmcorder POWER switch to VCR.

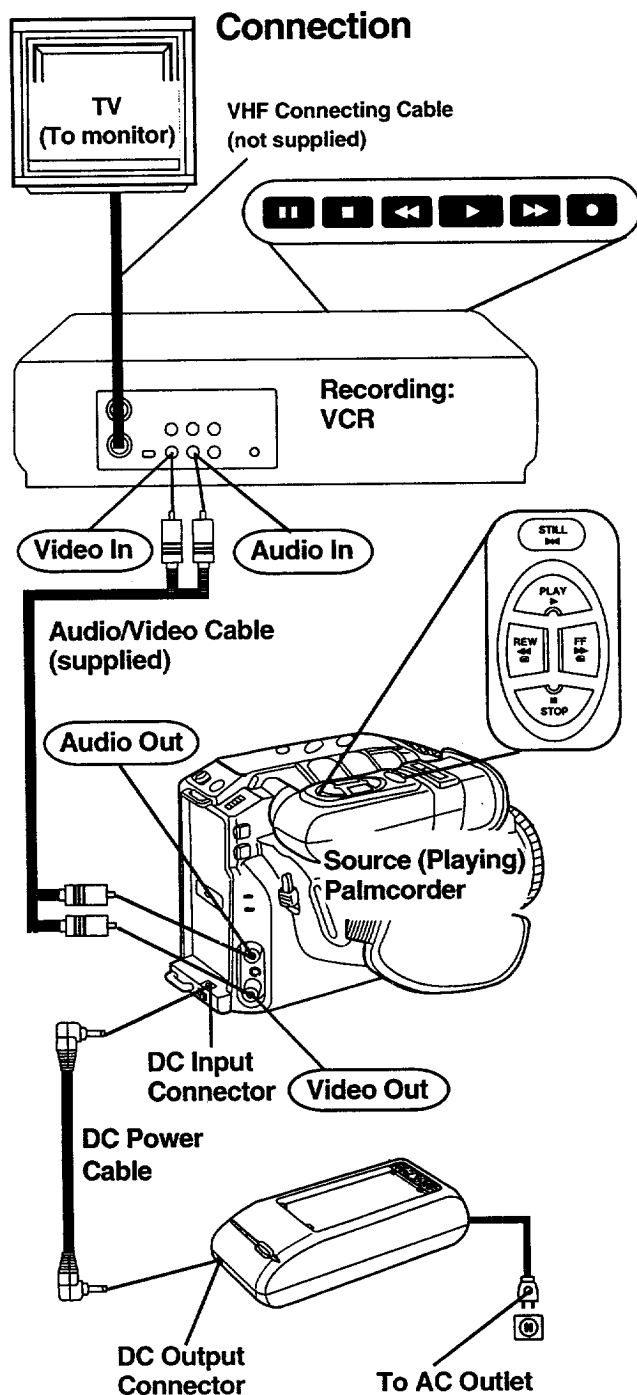

Main Operation

1

Insert a pre-recorded tape into the source (playing) Palmcorder and a blank tape with record tab into the editing (recording) unit.

2



Press **PLAY** on the (playing) Palmcorder.

3



Press **STILL** when the tape reaches the point you want to start dubbing.

4



Press **PLAY** and **REC** together then immediately press **STILL** on the recording unit.

5

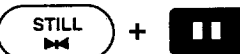

Press **STILL** on the playing Palmcorder and **PAUSE/STILL** on the recording unit to begin copying your tape.

6

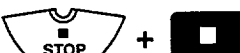

Press **STOP** on both units when dubbing is complete.

Monitor with your TV

- Turn the TV ON and select its VCR channel (either CH3 or CH4).
- Set the VCR/TV Selector on the recording VCR to VCR.

CAUTION:

Unauthorized exchanging and/or copying of copyrighted recordings may be copyright infringement.

Notes on Operations

Car Battery Cord (P. 9)

- Be sure to start your car engine before inserting the cigarette lighter plug of the Car Battery Cord into the lighter socket; otherwise, the cigarette lighter plug fuse may burn out.
- Because the car is running while your Palmcorder is in operation, make sure you're in a ventilated area.
- Disconnect the cigarette lighter plug when your Palmcorder is not being used.

Note:

The Car Battery Cord can only be used in vehicles equipped with DC 12V (negative ground) batteries.

Charging the Battery Pack (P. 8)

- The useful operation time of the Battery will gradually decrease after repeated use and recharging. The Battery is no longer serviceable if the operation time is very short, even after a sufficient charge.

Special Effects Playback (P. 19)

- During search playback, horizontal noise bars will appear and there will be no audio.
- To protect the tape and video heads, your Palmcorder's operating modes will revert as follows:

STILL → STANDBY after 5 minutes.

STANDBY → POWER OFF after 5 minutes when using a Battery Pack.

- When the tape reaches its end during playback, or fast forward, it will rewind automatically.

High Speed Shutter (P. 24)

- For proper color reproduction, it is recommended that you use this feature outdoors. For indoor High Speed Shutter recording, additional halogen or tungsten light should be provided. Fluorescent light will degrade the picture quality.
- This feature requires ample light. More light is required for the fastest shutter speeds.
- The Auto Focus system may not operate properly in insufficient light when using the High Speed Shutter.

Copying your Tapes (P. 25)

- Tapes recorded on other VCRs for use with the Palmcorder must be recorded in SP or SLP mode.
- For technical reasons, dubbing a tape may reduce its quality.

CCD Warning

When your Palmcorder is aimed at excessively bright objects, such as the sun or other bright lighting, a vertical bar may appear in the picture. This is a normal characteristic of the CCD pick-up device. Try to avoid aiming the camera at extremely bright objects.

CATV System Installer

This reminder is provided to call the CATV system installer's attention to Article 820-40 of the NEC in USA (and to the Canadian Electrical code in Canada) that provides guidelines for proper grounding and, in particular, specifies that the cable ground shall be connected to the grounding system of the building, as close to the point of cable entry as practical.

Encountering Blank Tape

If a blank section of tape is encountered in the play mode, the screen will be jumbled until a recorded signal is again detected. This is normal.



Auto White Balance System

When the Palmcorder is turned on, it takes a few seconds for the colors to stabilize while the Auto White Balance is being activated.

Auto-Reset

The Palmcorder, provided no tape is inserted, will reset the Backlight, High Speed Shutter and Focus to their AUTO or OFF modes if, after activation, none of these buttons are pressed within 5 minutes.

Attaching Optional Filters and Lenses

Remove the Lens Hood by turning it counterclockwise.

Then attach an optical filter or lens.

- Be careful not to touch the lens itself.
- Replace the Lens Hood after removing the accessory.

Cleaning the EVF

PV-IQ304

Turn the EVF Eyepiece counterclockwise 1/8 of a turn ① and pull free ②.

Remove any lint or dust particles with a soft clean cloth being careful not to scratch the glass surfaces. Line up the marks on the Eyepiece with the grooves inside the EVF shaft and attach. Turn the EVF clockwise 1/8 of a turn to lock in place.

To Remove

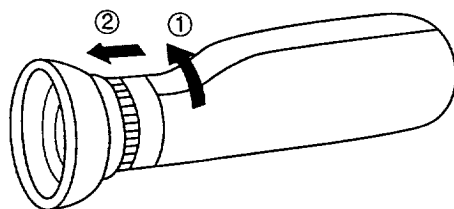

PV-IQ404

While sliding the EYEPIECE REMOVE button ①, remove the eyepiece ②. (Do not twist.)

Then, remove any lint or dust particles with a blower, available at photography stores. Do not touch lenses with fingers.

Now, replace the eyepiece.

To Remove

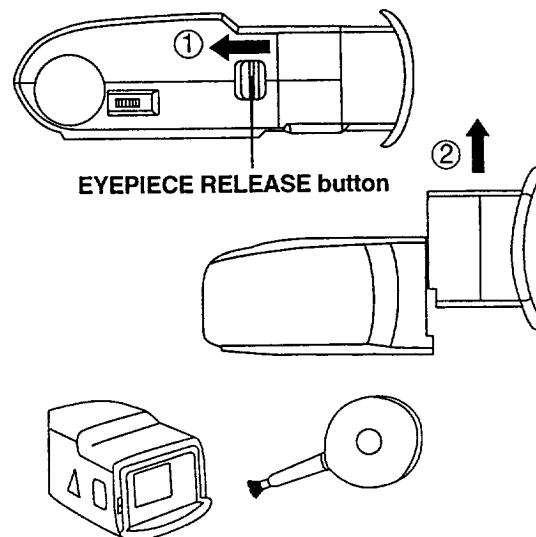

FCC Warning: Any unauthorized changes or modifications to this equipment would void the user's authority to operate.

This device complies with Part 15 of the FCC Rules. Operation is subject to the following two conditions: (1) This device may not cause harmful interference, and (2) this device must accept any interference received, including interference that may cause undesired operation.

Note: This equipment has been tested and found to comply with Part 15 and part 18 of the FCC Rules. These limits are designed to provide reasonable protection against harmful interference when operated in a residential environment.

If this equipment does cause interference to radio or television reception, which can be determined by turning the equipment off and on, use the equipment in another location and/or utilize an electrical outlet different from that used by the receiver.

If necessary, consult the dealer or an experienced radio/TV technician for help. You may find the booklet, 'Something About Interference' available from FCC local regional offices helpful.

Spanish Quick Use Guide/Guía Para Uso Rápido

PREPARATIVOS

- Conectar la videocámara a una fuente de alimentación (batería, adaptador de CA o cable para batería de coche).
- Encender el aparato.
- Introducir el casete en el compartimiento de casetes.

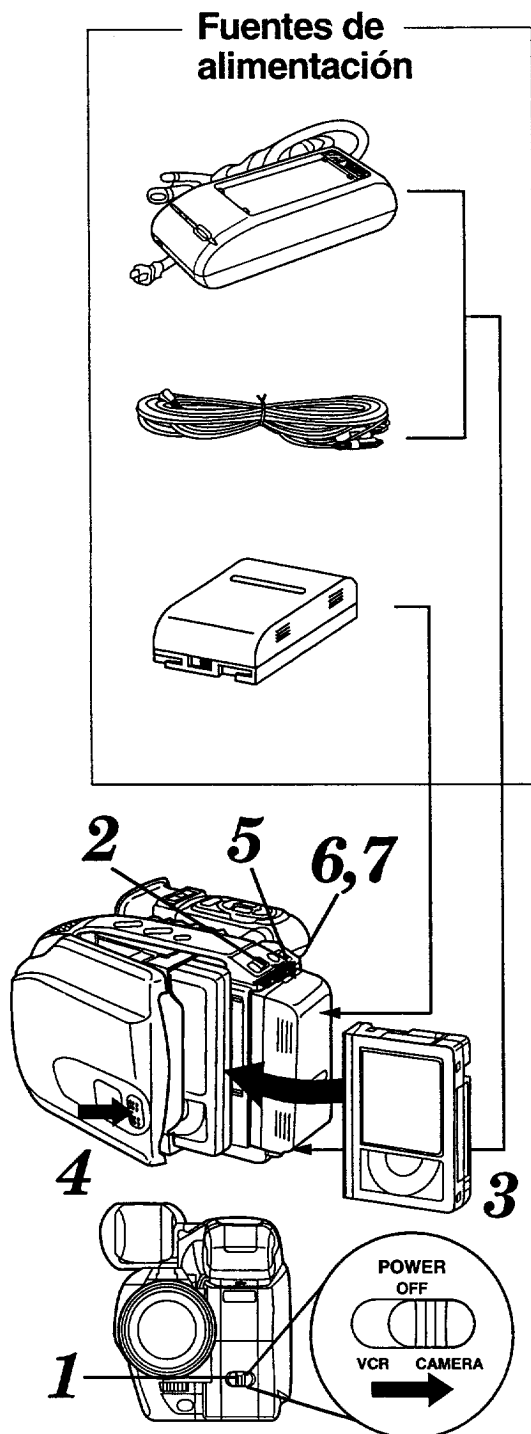

GRABACION

- 1** **POWER OFF**

VCR CAMERA

Fije el interruptor a la posición de CAMERA.
- 2** **TAPE EJECT**

Deslice el botón EJECT para abrir la puerta.
- 3**

Introduzca la cinta.
- 4**

Cierre la puerta presionando el botón PUSH TO CLOSE.
- 5** **SPEED**

SP SLP

Seleccionar la velocidad de grabación.
- 6**

AUTO-HSS PAUSE REC

Oprimir el botón de grabación/pausa (RECORD/PAUSE) para comenzar a filmar.
- 7**

AUTO-HSS PAUSE

Volver a oprimir el botón de grabación/pausa (RECORD/ PAUSE) cuando se desea hacer una pausa en la grabación.

Spanish Quick Use Guide/Guía Para Uso Rápido

- Conectar la videocámara a una fuente de alimentación (batería, adaptador de CA o cable para batería de coche).
- Encender el aparato.
- Introducir el casete en el compartimiento de casetes.

En el visor

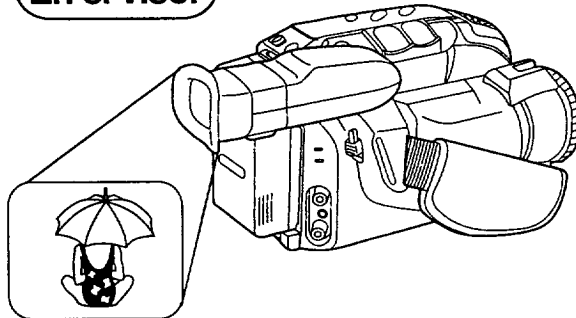

En la TV

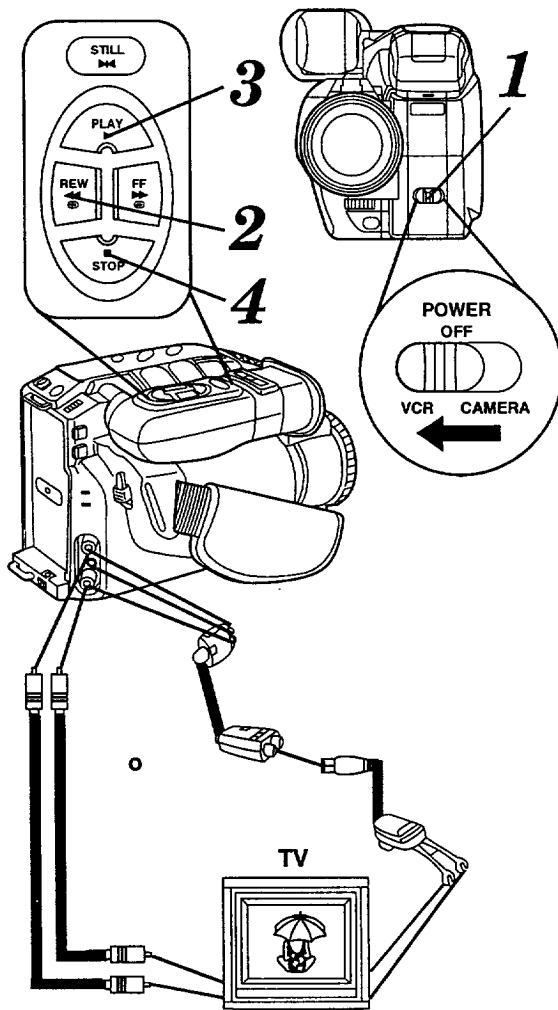

REPRODUCCION NORMAL

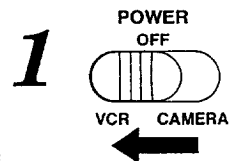

Fije el interruptor a la posición de VCR.



Rebobinar la cinta con el botón de rebobinado (REWIND) (si fuera necesario).

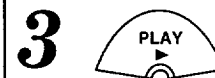

Oprimir el botón de reproducción (PLAY) para que aparezcan las imágenes en la pantalla.

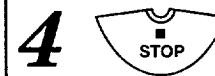

Oprimir el botón de parada (STOP) cuando se desea parar la reproducción.

REPRODUCCION CON EFECTOS ESPECIALES

PARA LOCALIZAR RAPIDAMENTE UNA ESCENA ESPECIFICA

- Oprimir el botón de localización (SEARCH).

PARA CONGELAR UNA IMAGEN

- Oprimir el botón de pausa/imagen fija (PAUSE/STILL).
- Oprimir nuevamente el botón cuando se desea continuar reproduciendo.

Index of Controls

Front View

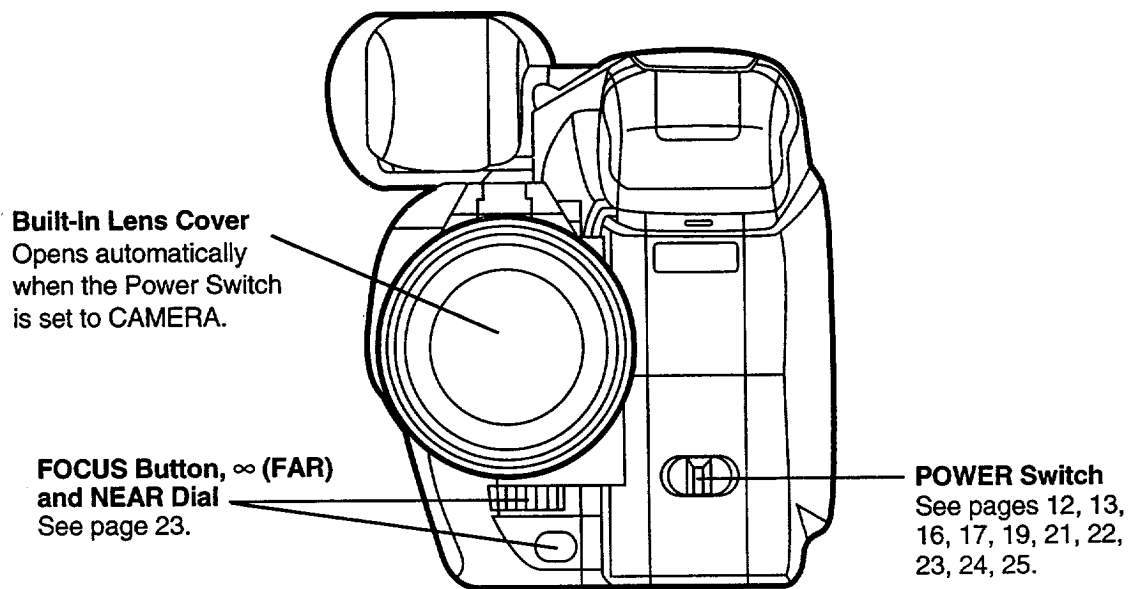
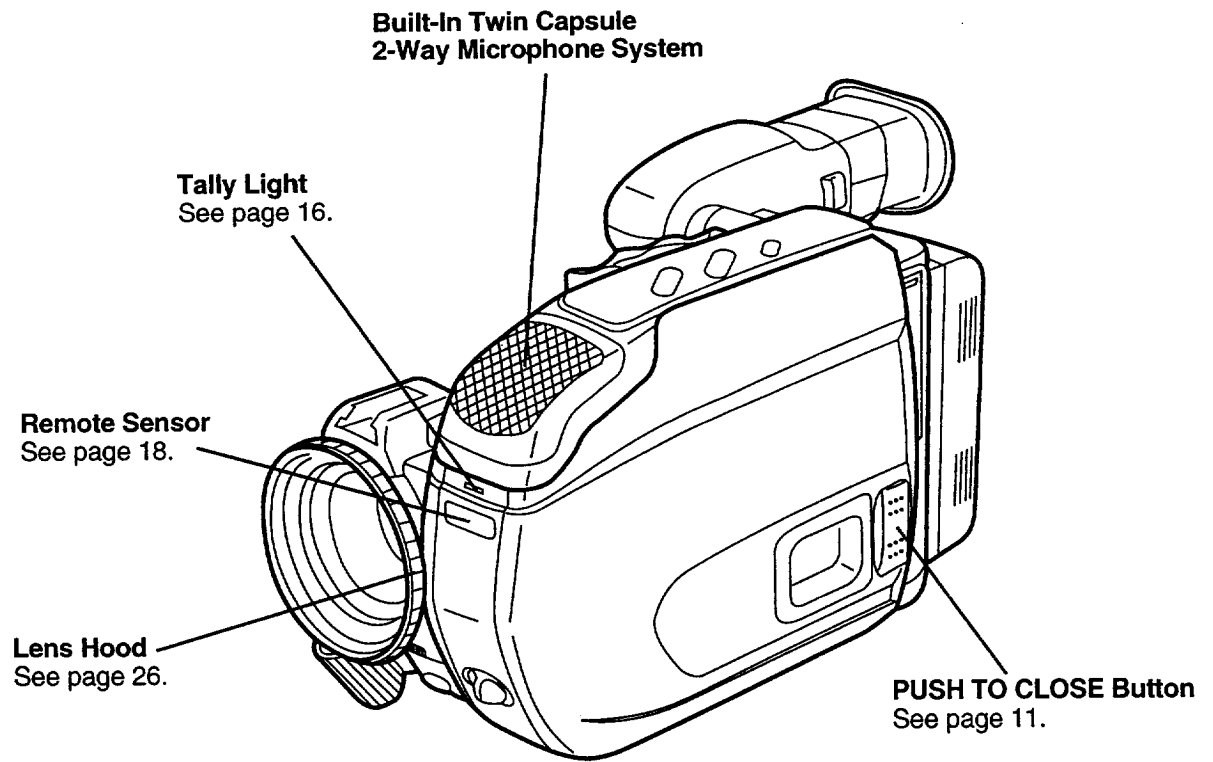

Index of Controls

Rear View

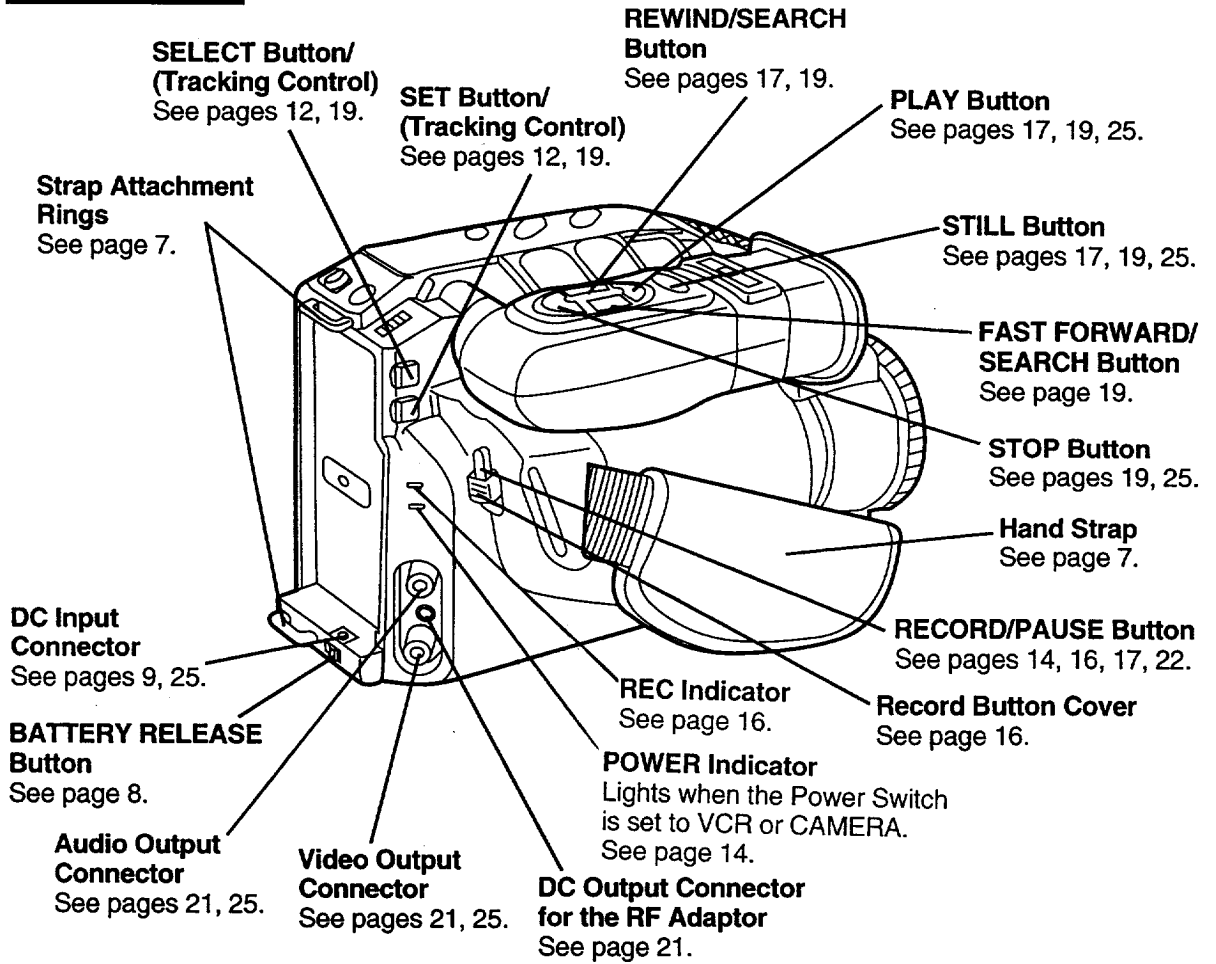

Underside View

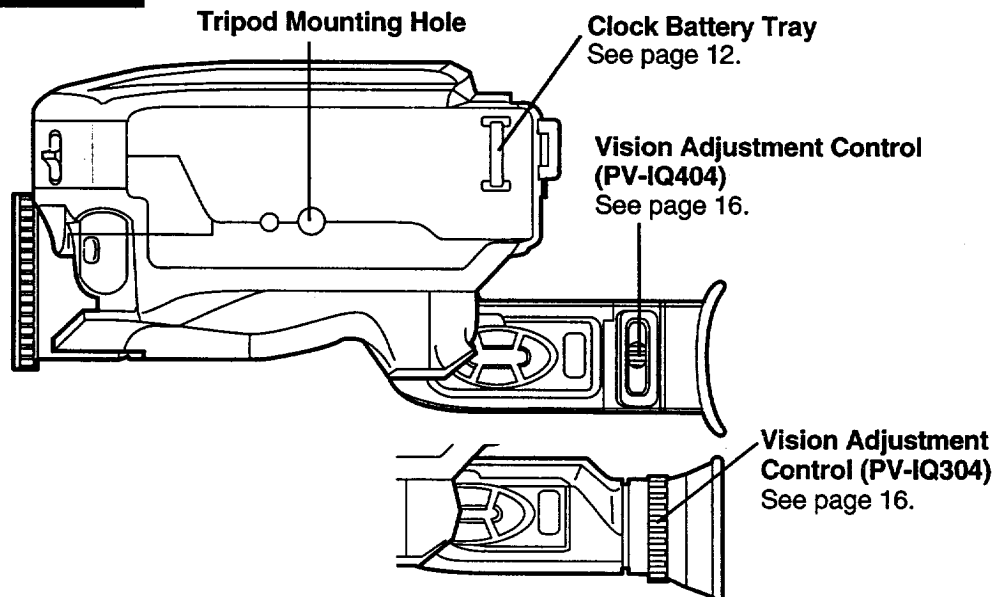

Index of Controls

Top View

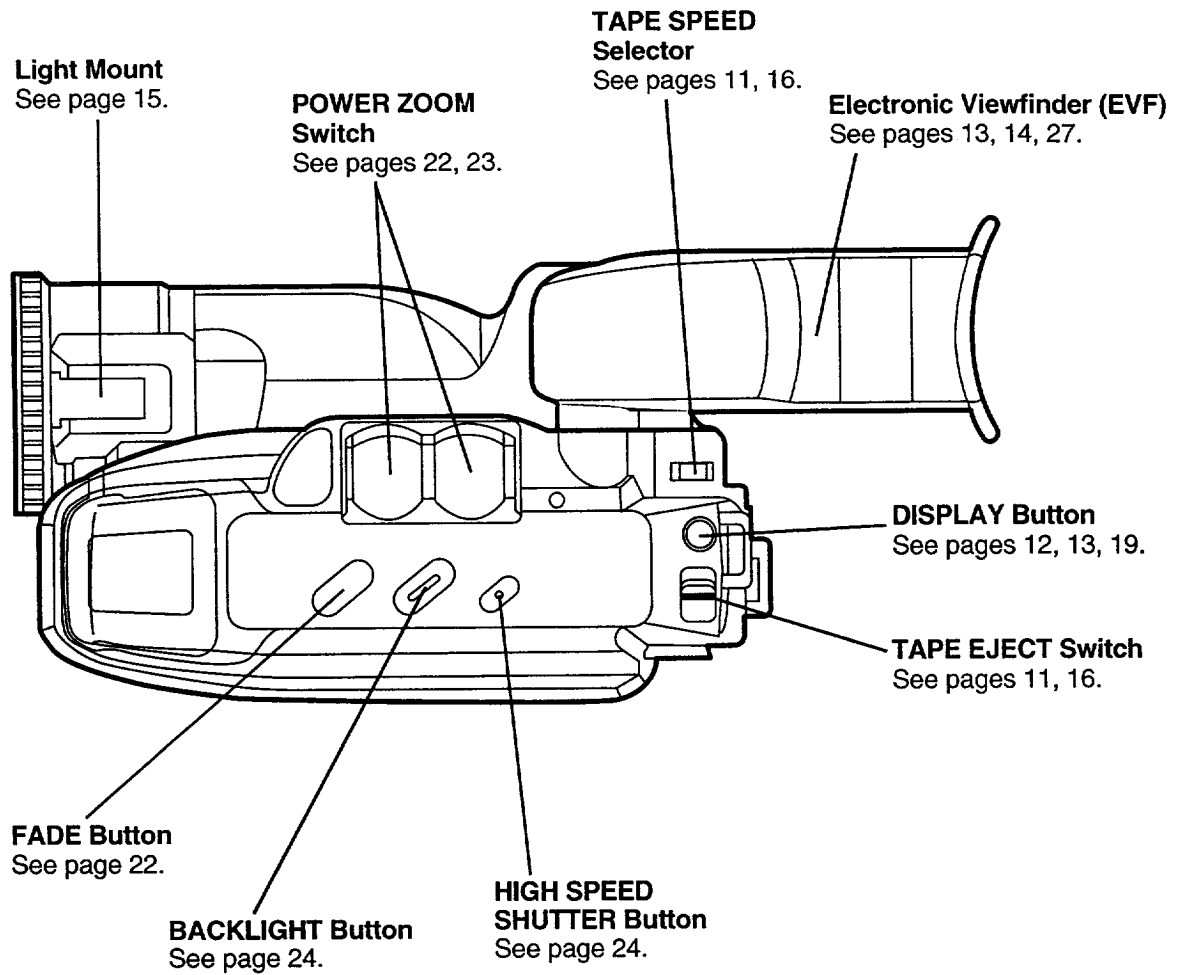

PV-IQ404

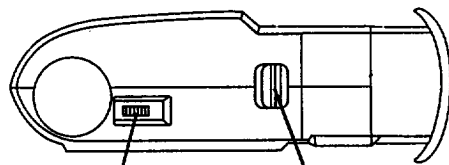

Bright Control
Adjust the brightness of the picture.

EYEPIECE RELEASE button
See page 27.

PV-IQ304

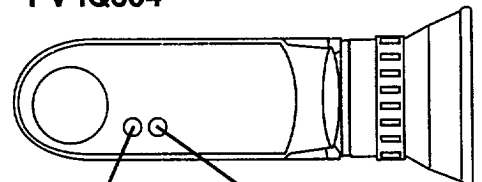

***Focus Control**
Adjust the focus of the picture on the EVF.

***Bright Control**
Adjust the brightness of the picture.

***Note:** These controls have been set at the factory. It is not necessary to adjust these controls under normal circumstances. But, should it become necessary, be careful to make the adjustment with a small, slender screwdriver so as not to damage the miniature control.

8-Function Remote

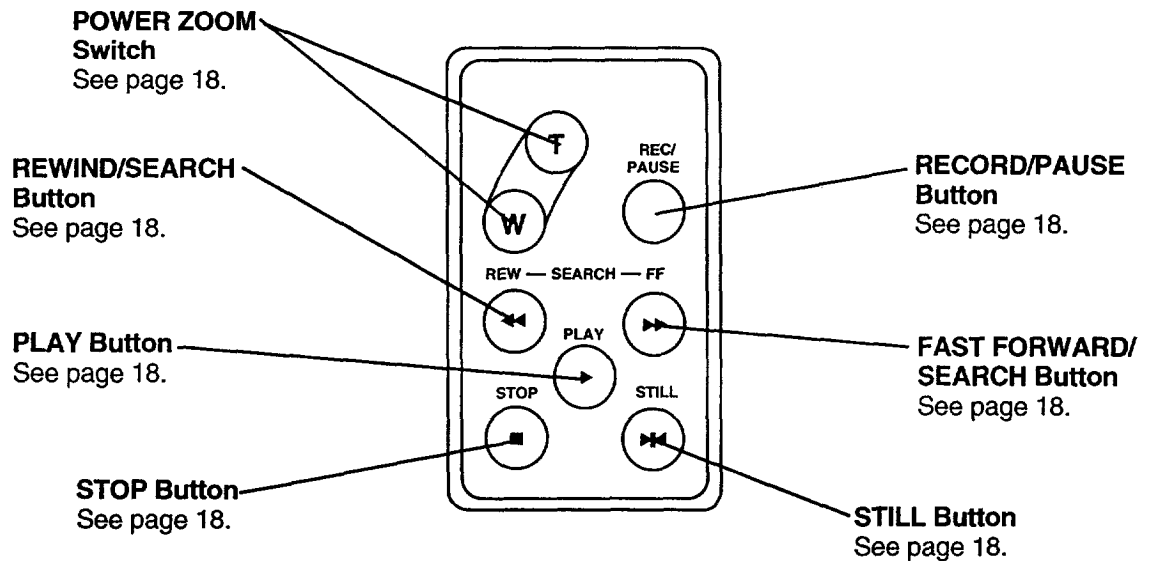

AC Adaptor

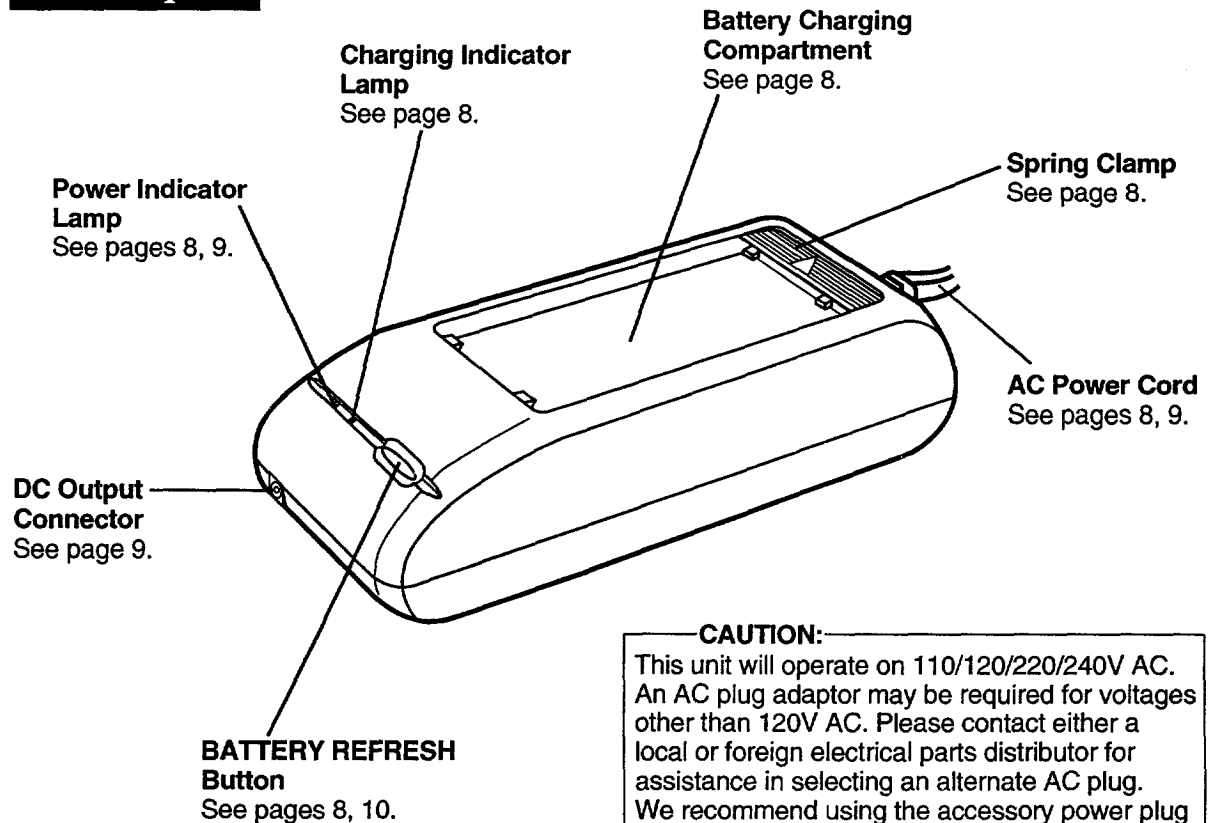

CAUTION:

This unit will operate on 110/120/220/240V AC. An AC plug adaptor may be required for voltages other than 120V AC. Please contact either a local or foreign electrical parts distributor for assistance in selecting an alternate AC plug. We recommend using the accessory power plug adaptor (VJSS0070) in an area which has special AC outlets.

Index

10-Second Reminder	14	Clock Battery	2, 12	Rec Indicator	14
Accessories (Optional/ Supplied)	2, 6	Color Enhancement Light ..	15	RF Adaptor	6, 21
Audio/Video		Copying your Tapes ..	25, 26	Safety Precautions	2
Cable	2, 6, 21, 25	DC Power Cable	2, 9, 25	Search Speed	19
Auto Focus	23	Dew Indication	14	Shoulder Strap	2, 6, 7
Automatic Easy Edit		Display off Mode	21	Special Effects	
Standby	17	Erase Protection	11	Playback	19, 26
Auto-Reset	26	EVF Indications	13, 14	Specifications	34
Battery Pack	2, 6, 8, 10	Fade In/Out	22	Still Picture	19
Battery Remaining		High Speed Shutter ...	24, 26	Symptom/Correction	35
Indication	13	High Speed Shutter		Tab	11
Battery Warning	14	Indicator	24	Tape Warning	14
Camera Recording	16	Macro Focus	23	Tracking Control	19
Car Battery Cord	6, 9, 26	Manual Focus	23	VCR-MODE Indication	14
CH 3/4 Switch	21	Monitor	21	VHF Connecting	
Charging Battery	8, 26	Play Indicator	14	Cable	21, 25
Cleaning Care for		Playback	19	Video Cassettes	
Video Heads	35	PlayPak	20	(tapes)	6, 11
		Power Supply	8, 9, 10	Zoom In/Out	22

Specifications

Power Source:	Compact VHS Palmcorder: DC 6V AC Adaptor: 110/120/220/240V AC, 50/60 Hz Battery: Nickel-Cadmium Type DC 6V
Power Consumption:	Compact VHS Palmcorder: 6V DC 10W (Max. 15W) AC Adaptor: 24W
Video Signal:	EIA Standard (525 lines, 60 fields) NTSC color signal
Video Recording System:	2 rotary heads. helical scanning system
Audio:	1 track
Pick-Up System:	Sequential color difference field reverse system
Pick-Up Device:	One integral color filter Charge Coupled Device (CCD)
Lens:	12:1 zoom lens, F1:1.6 with auto iris control Focal length: 5.4mm - 64.8mm Power zoom function Lens filter diameter: 49mm
Viewfinder:	0.7 inch (17.8mm) Liquid Crystal Color Electronic Viewfinder (PV-IQ404) 1/2 inch (12.7mm) Electronic Viewfinder (PV-IQ304)
Minimum Illumination Required:	1 lx (F1:1.6) 0.1 footcandles
Operating Temperature:	32°F~104°F (0°C~40°C)
Operating Humidity:	10%~75%
Weight:	Compact VHS Palmcorder: 1.9 lbs. 0.86kg AC Adaptor: 0.77 lbs. 0.35kg
Dimensions:	Compact VHS Palmcorder: 4-1/8 (W) × 4-5/8 (H) × 6-7/8 (D) inch 104 (W) × 116 (H) × 175 (D) mm AC Adaptor: 2-3/4 (W) × 1-5/8 (H) × 6-1/4 (D) inch 70 (W) × 41 (H) × 158 (D) mm

Weight and dimensions shown are approximate.
Designs and specifications are subject to change without notice.

Before Requesting Service

If you have a problem with your Palmcorder, it may be something you can correct yourself. Check the list below for symptoms and corrections.

Symptom	Correction
No picture in the EVF ...	<ul style="list-style-type: none"> • Make sure the Power Source is connected. (pp. 8, 9) • Make sure the POWER switch is set to VCR or CAMERA. (pp. 16, 19) • Check the Dew Indicator. (p. 14) • Make sure the battery is fully charged. (p. 8) • Make sure all necessary cables are connected correctly and firmly. (p. 21)
Video cassette can't be inserted ...	<ul style="list-style-type: none"> • Make sure the Power Source is connected. (pp. 8, 9) • Insert the cassette with the window side facing out. (p. 11)
Video cassette can't be removed ...	<ul style="list-style-type: none"> • Make sure the Power Source is connected. (pp. 8, 9)
No operation starts when operation buttons are pressed ...	<ul style="list-style-type: none"> • Check the Dew Indicator. (p. 14)
Recording cannot be done ...	<ul style="list-style-type: none"> • Make sure the record tab is still intact. (p. 11) • Check the Battery Indicator. (p. 13) • Check the Dew Indicator. (p. 14)
Auto Focus does not operate ...	<ul style="list-style-type: none"> • Make sure the FOCUS button is set to AUTO. (p. 23) • Make sure the unit is ON, with the POWER switch set to CAMERA (p. 16).
Sound from microphone can't be monitored ...	<ul style="list-style-type: none"> • Make sure the unit is set to REC or Record/Pause mode.
Camera picture is too dark ...	<ul style="list-style-type: none"> • Make sure the HIGH SPEED SHUTTER button is OFF (p. 24).
No playback picture, or the playback picture is noisy or contains streaks ...	<ul style="list-style-type: none"> • Press the SET or SELECT button (Tracking Control) (p. 19).
During playback, the picture shows motion or blurred action ...	<ul style="list-style-type: none"> • Portions of the still picture where the normal speed motion was particularly rapid may produce this effect. This is normal.
"Panasonic Palmcorder IQ IT'S VHS SO ITS TAPES PLAY IN YOUR VCR" appears in the EVF and Monitor ...	<ul style="list-style-type: none"> • Set the POWER switch to OFF and then CAMERA.
If the top of your playback picture waves back and forth excessively ...	<ul style="list-style-type: none"> • Because the playback signal is not as stable as an off the air TV signal, the top of your TV screen may be bent or unstable when the tape is played back. This symptom is more noticeable when a tape, recorded on another VCR, is played back. To solve this problem, locate the horizontal hold control on your TV. Turn it slowly to correct the wavy picture. If your TV does not have a horizontal hold control or adjusting the control does not help, some modifications may have to be made to the TV set. Technically this is called "Horizontal AFC time constant change." If such a problem exists, please contact your local TV service center. (Some nominal service charges are required.)

Cleaning Care for Video Heads



Clogged Video Head

(a) Video Head Cleaning: Your Palmcorder will not normally require head cleaning; however, it is possible that the heads may become clogged when playing an old or damaged tape. If the image on your screen resembles the photograph on the left while playing back a tape, the heads may require cleaning.

(b) Cleaning the Heads: It is recommended that head cleaning be performed by a qualified service technician. Please contact your nearest Panasonic Service Center. An alternate solution is to obtain a head cleaning cassette. There are many types of cleaning cassettes, so be sure to follow the cleaning instructions carefully. Excessive use of the cleaning cassette could shorten head life. Use this cassette only when a head clogging symptom occurs.

Refer servicing to qualified service personnel.

Panasonic®

Panasonic Company
Division of Matsushita Electric
Corporation of America
One Panasonic Way, Secaucus,
New Jersey 07094

Panasonic Company (West) of America,
Division of Matsushita Electric
Corporation of America
6550 Katella Ave.
Cypress, CA 90630

Panasonic Sales Company,
Division of Matsushita Electric
of Puerto Rico, Inc.
San Gabriel Industrial Park
65th Infantry Avenue KM 8.5
Carolina, Puerto Rico 00630

Printed in Japan
VQTW0464 Ⓐ

